



Chief Editor

Dr. A. Singaraj, M.A., M.Phil., Ph.D.

Editor

Mrs.M.Josephin Immaculate Ruba

Editorial Advisors

1. Dr.Yi-Lin Yu, Ph. D
Associate Professor,
Department of Advertising & Public Relations,
Fu Jen Catholic University,
Taipei, Taiwan.
2. Dr.G. Badri Narayanan, PhD,
Research Economist,
Center for Global Trade Analysis,
Purdue University,
West Lafayette,
Indiana, USA.
3. Dr. Gajendra Naidu.J., M.Com, LL.M., M.B.A., PhD. MHRM
Professor & Head,
Faculty of Finance, Botho University,
Gaborone Campus, Botho Education Park,
Kgale, Gaborone, Botswana.
4. Dr. Ahmed Sebihi
Associate Professor
Islamic Culture and Social Sciences (ICSS),
Department of General Education (DGE),
Gulf Medical University (GMU), UAE.
5. Dr. Pradeep Kumar Choudhury,
Assistant Professor,
Institute for Studies in Industrial Development,
An ICSSR Research Institute,
New Delhi- 110070.India.
6. Dr. Sumita Bharat Goyal
Assistant Professor,
Department of Commerce,
Central University of Rajasthan,
Bandar Sindri, Dist-Ajmer,
Rajasthan, India
7. Dr. C. Muniyandi, M.Sc., M. Phil., Ph. D,
Assistant Professor,
Department of Econometrics,
School of Economics,
Madurai Kamaraj University,
Madurai-625021, Tamil Nadu, India.
8. Dr. B. Ravi Kumar,
Assistant Professor
Department of GBEH,
Sree Vidyanikethan Engineering College,
A.Rangampet, Tirupati,
Andhra Pradesh, India
9. Dr. Gyanendra Awasthi, M.Sc., Ph.D., NET
Associate Professor & HOD
Department of Biochemistry,
Dolphin (PG) Institute of Biomedical & Natural Sciences,
Dehradun, Uttarakhand, India.
10. Dr. D.K. Awasthi, M.SC., Ph.D.
Associate Professor
Department of Chemistry, Sri J.N.P.G. College,
Charbagh, Lucknow,
Uttar Pradesh. India

ISSN (Online) : 2455 - 3662

SJIF Impact Factor :5.148

EPRA International Journal of Multidisciplinary Research

Monthly Peer Reviewed & Indexed
International Online Journal

Volume: 5 Issue: 3 March 2019



Published By :EPRA Publishing

CC License





EMBEDDED ACCIDENT PREVENTION SYSTEM FOR E-VEHICLE

Dr.M.Balaji

Assistant Professor,
Dr.Mahalingam college of Engineering and
Technology,
Pollachi, T.N,
India

T.Sharan

Dr.Mahalingam college of Engineering and
Technology,
Pollachi, T.N,
India

P.Kiruba

Dr.Mahalingam college of Engineering and
Technology,
Pollachi, T.N,
India

B.Kamali

Dr.Mahalingam college of Engineering and
Technology,
Pollachi, T.N,
India

V.Tamilarasu

Dr.Mahalingam college of Engineering and Technology,
Pollachi, T.N,
India

ABSTRACT

"There is one death for every four minutes due to road accidents in India", the Hindu Newspaper, dated 10th October 2015. About 1,37,000 people were killed in road accidents in recent years, which is more than the number of people killed in all wars put together. Millions of people have lost their lives due to road accidents and become physically disabled. Traffic accidents can cause physical, financial and mental effects for everyone involved. It leads to the reduction of savings and liquidity. As a long term effect accidents increase the risk of cancer and acts as a threat to the future generation. The main reason for road accidents are rash driving, drunken driving, human's lag in response to panic situation and human distractions. The foremost objective is to propose a system which would reduce the accidents caused by the driver and save human lives. The other objective in this proposal is to conserve the energy utilization of the vehicle during idle conditions. In order to avoid the accidents caused by the drivers it is proposed to use combination of sensors, brake control circuit embedded in E-vehicle. The sensor circuits are integrated so as to maintain 10meter distance between the vehicle and obstacles(It might be a person or tree or other vehicle). There are two modes of operations in the proposed system, namely manual mode and autonomous mode. Under normal circumstances, the vehicle will be in manual mode, i.e the control of the vehicle is with the human. In case of emergency (undesirable scenarios while driving), the autonomous mode proposed system will take over the control. If unknowingly driver gets distracted and tends to cause an accident, the vehicle switches from manual to automatic mode and apply the brakes automatically and prevents the accident. Finally, the system will reduce the accidents and saves the lives of future.

I. INTRODUCTION

Accidents are uncertain. The mostly used automobiles by the people is two wheeler vehicles like bike, scooter. There are many accidents due to human's lag in response to the panic situation. The frequency of traffic collisions in India is amongst the highest in the world. More than 40% of casualties are associated with bikes and trucks. It is mainly due to lack of maintaining lane or yield to oncoming traffic and turning are prime causes of accidents. When anyone owns a two wheeler, the chance of accident is more. Two wheelers account for 25% of total road crash deaths. Hence, the system has been proposed using tri wheeled electric vehicle in which the system is applicable for two wheeler also. There are many systems which prevent the road accidents. They are as follows, Real time embedded

system for accident prevention, Cost effective road accident prevention system, Intelligent transportation system for accident prevention and detection, Accident prevention system based on semantic network, An arduino based accident prevention and identification system for vehicles. Through literature survey it has been identified that many systems have been proposed for the prevention of road accidents. But those systems was very complex and those are very difficult to implement in vehicles. Added to that the systems have been proposed for all automobiles. But as per the latest survey nearly 25% of road accidents are due to the two-wheelers. The accident by two wheelers are mostly due to human's lag in response to panic situation and in emergency cases. Hence, an efficient and simple system is needed to prevent the road accidents.

Type of collision	2017	2018
Head on collision	96466	87068
Hit from side	59097	77540
Hit and run	55942	65186
Hit pedestrian	46823	62344
Hit from back	48413	42675
Vehicle overturn	48558	30037
Others	125353	100060
Total	480652	464910

Table 1: Road accidents caused by the type of collisions

1.1. Aim and objectives

The foremost aim is to propose a simple and efficient system which would reduce the accidents caused by the driver and save human lives. The objectives of the proposed system is as follows;

- To prevent the road accidents by making an system with combination of sensors and by developing an efficient Braking control system in e-vehicle
- To prevent the hit from side collisions by developing efficient Collision prevention system

II. METHODOLOGY

In order to avoid the accidents caused by the drivers it is proposed to use combination of sensors, brake control circuit embedded in E-vehicle. The sensor circuits are integrated so as to maintain 10meter distance

between the vehicle and obstacles(it might be a person or tree or other vehicle). There are two modes of operations in this proposed system, namely manual mode and autonomous mode. Under normal circumstances, the vehicle will be in manual mode, i.e the control of the vehicle is with the human. In case of emergency (undesirable scenarios while driving), the proposed system will take over the control. If unknowingly driver gets distracted and tends to cause an accident, the vehicle switches from manual to automatic mode and apply the brakes automatically and prevents the accident. Finally, this system will reduce the accidents and saves the hopes of future.

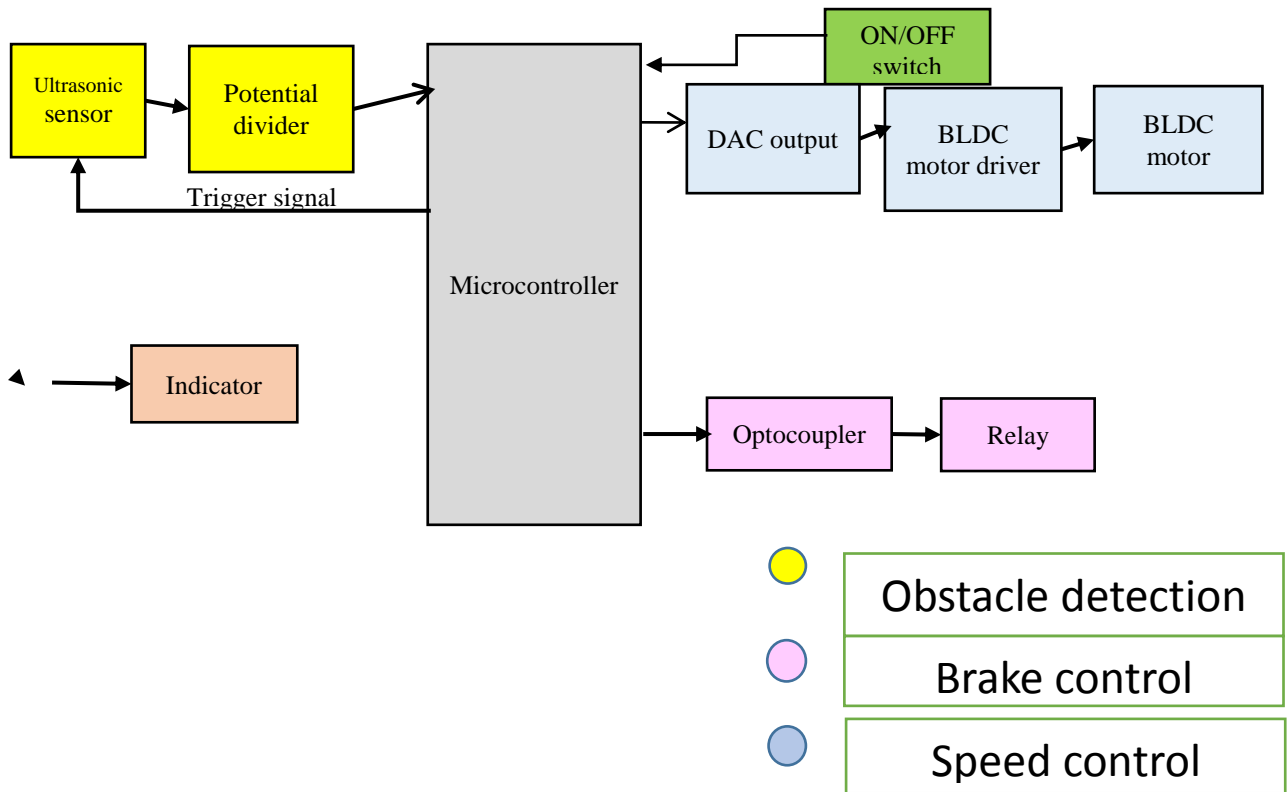

Fig.1. Block diagram of the system (Autonomous mode)

To prototype the proposed system, a tri-wheeled e-vehicle is used. It is the combination of BLDC motor, Battery, DC to DC converter, BLDC motor controller. The vehicle is powered with DC 48 volt. Batteries are connected in series. The controller used is from k64F micro controller. The integrated circuits are needed to be interfaced with the system to prevent the accidents while the controller takes over the control (Autonomous mode). The circuits implemented are, circuit for obstacle detection, circuit for brake, circuit for speedometer. The details about the circuit description and the interfacing are as follows,

2.1. Obstacle detection system

The system is designed using ultrasonic sensor. The input signal from the sensor helps in detecting the obstacle distance from the vehicle and helps in preventing the vehicle from collision with the obstacle. HC-SR04 is an ultrasonic ranging module that provides 2 cm to 400 cm non-contact measurement function. The ranging accuracy can reach to 3mm and effectual angle is < 15°. It can be powered from a 5V power supply. There are two transducers, one to transmit and one to receive. Two transducers turn out to be cheaper, since a higher voltage is needed to transmit and switching modes using only one transducer takes a lot of analog circuitry.

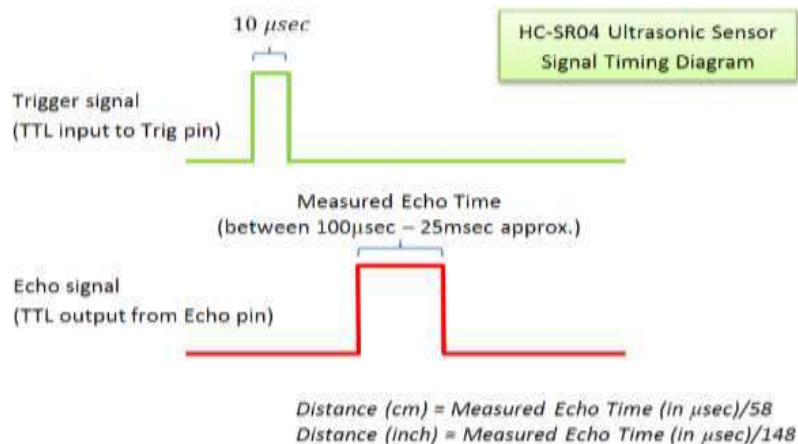
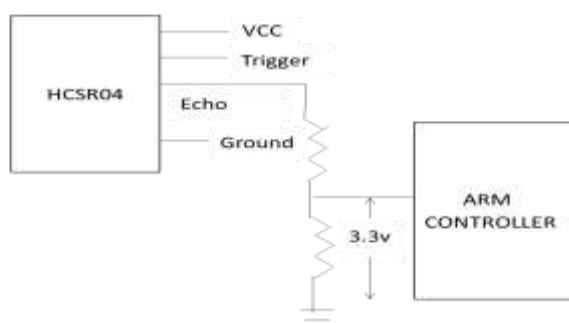

Fig.2.HC-SR04 Signal Timing Diagram

From the timing diagram above, only two signal pins are used. Trigger starts a measurement cycle and sends out a short ultrasonic pulse (eight cycles at 40Khz) and then listens for a reflected signal (echo). Several cycles at 40Khz are needed for the analog receiver circuit to detect the reflected signal. The width of the echo pulse output pin indicates distance. A hardware timer would typically be used to measure the echo pulse width

A simple divide operation can then scale the value to cm or inches, if needed. The device should not be triggered again until waiting for the longest possible echo return time delay (maximum detection distance

times speed of sound in air). This prevents any echoes from the previous ultrasonic pulse interfering with the next pulse measurement or the new outgoing pulse being heard as the echo from the previous pulse. Something a bit over 10 measurements per second is typical on most small sonar sensors. The obstacle can be detected during the autonomous mode of running by the circuit explained above and depending on the output from the ultrasonic sensor, speed of the vehicle is controlled. If the obstacle is at longer distance, the speed of the vehicle is high and vice versa. The speed of the vehicle and the output of the ultrasonic sensor are directly proportional to each other.

**Fig.3. Circuit Of Obstacle Detection system**

2.2.Brake control system

The brake control of the vehicle during the autonomous mode of running is achieved using relay. A relay is an electrically operated switch. Many relays use an electromagnet to mechanically operate a switch, but other operating principles are also used, such as solid-state relays. Relays are used where it is necessary to control a circuit by a separate low-power signal, or where several circuits must be controlled by one signal. The first relays were used in long distance telegraph circuits as amplifiers: they repeated the signal coming in from one circuit and re-transmitted it on another circuit. Relays were used extensively in telephone exchanges and early computers to perform logical operations.

A type of relay that can handle the high power required to directly control an electric motor or other loads is called a contactor. Solid-state relays control power circuits with no moving parts, instead using a semiconductor device to perform switching. Relays with calibrated operating characteristics and sometimes multiple operating coils are used to protect electrical circuits from overload or faults; in modern electric power systems these functions are performed by digital instruments still called "protective relays".

Magnetic latching relays require one pulse of coil power to move their contacts in one direction, and

another, redirected pulse to move them back. Repeated pulses from the same input have no effect. Magnetic latching relays are useful in applications where interrupted power should not be able to transition the contacts. Magnetic latching relays can have either single or dual coils. On a single coil device, the relay will operate in one direction when power is applied with one polarity, and will reset when the polarity is reversed. On a dual coil device, when polarized voltage is applied to the reset coil the contacts will transition. AC controlled magnetic latch relays have single coils that employ steering diodes to differentiate between operate and reset commands.

2.2.1.Relay interfacing using optocoupler

The input signal from the controller is given to the optocoupler. Opto coupler is used to protect the device. An optoisolator (also known as optical coupler, optocoupler, opto-isolator) is a semiconductor device that uses a short optical transmission path to transfer an electrical signal between circuits or elements of a circuit, while keeping them electrically isolated from each other. These components are used in a wide variety of communications, control and monitoring systems that use light to prevent electrical high voltage from affecting a lower power system receiving a signal.

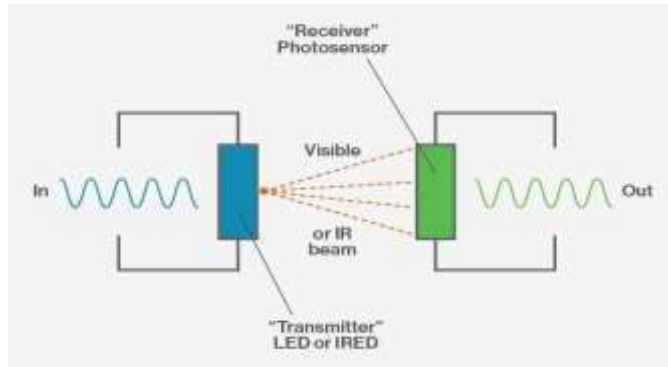

Fig.4. Structure of Opto-isolator

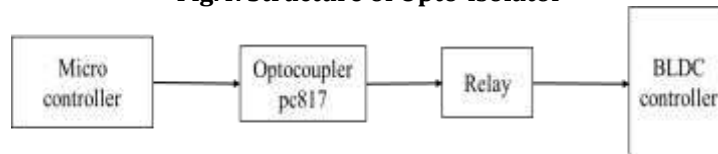

Fig.5. Block diagram of brake system interface

In its simplest form, an optoisolator consists of a light-emitting diode (LED), IRED (infrared-emitting diode) or laser diode for signal transmission and a photosensor (or phototransistor) for signal reception. Using an optocoupler, when an electrical current is applied to the LED, infrared light is produced and passes through the material inside the optoisolator. The beam travels across a transparent gap and is picked up by the receiver, which converts the modulated light or

IR back into an electrical signal. In the absence of light, the input and output circuits are electrically isolated from each other. Electronic equipment, as well as signal and power transmission lines, are subject to voltage surges from radio frequency transmissions, lightning strikes and spikes in the power supply. To avoid disruptions, optoisolators offer a safe interface between high-voltage components and low-voltage devices.

Hardware Implementation

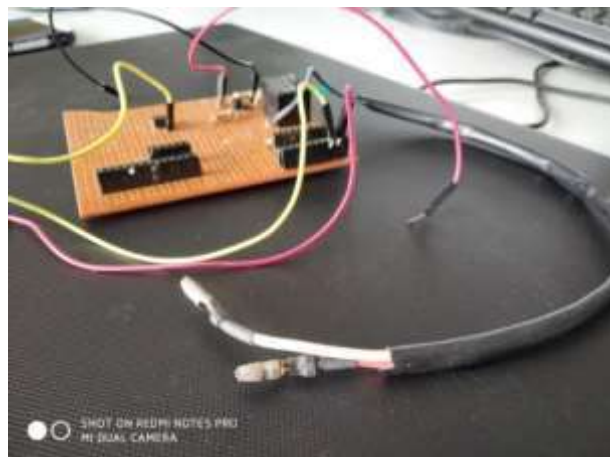

Fig.5. Snapshot of brake control circuit board

2.3.Speed measurement system

The speed measurement system of the vehicle is designed using IR sensor module. This system is mainly designed to measure the speed of the vehicle during the autonomous mode of running.

- A piece of aluminium foil is pasted on the tyre and whenever the IR sensor senses the foil the output voltage goes maximum.
- Whenever it senses the black colour of tyre output voltage goes minimum.
- Interrupt pin of Micro controller records the changes that occur in output.
- The speed calculation is done by programming the micro controller.
- The output pin is connected to analog pin and one interrupt of micro controller is used.
- An interrupt pin which records change occur in output(for black-minimum voltage to for aluminium foil-maximum voltage)
- $RPM = (60000 / \text{duration})$
- $\text{Speed in km/hour} = (2 * 3.14 * r * 60) / 1000$

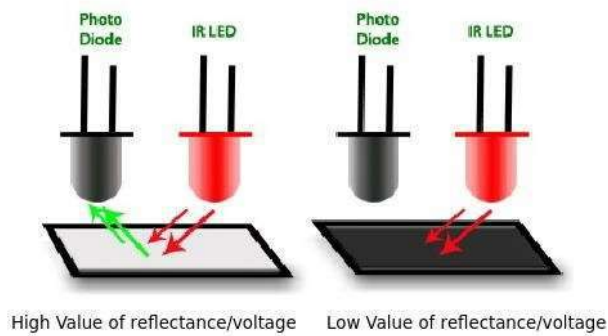

Fig.6.IR sensor reflection for various light intensities

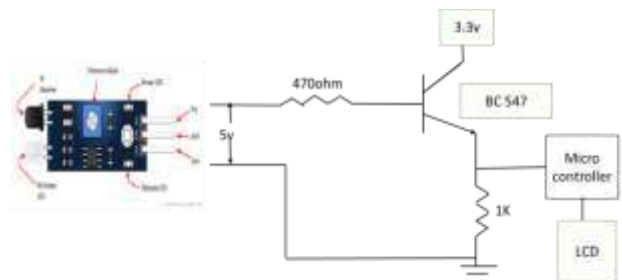

Fig.7.Circuit diagram of speed measurement system

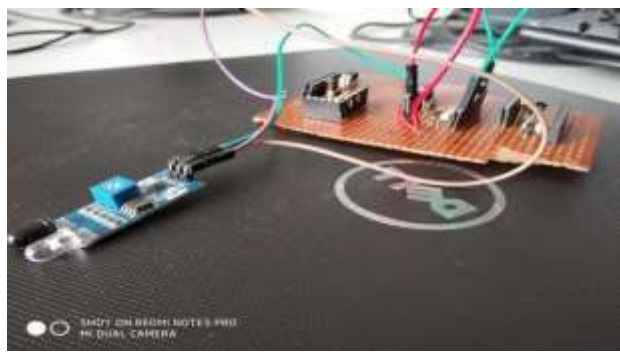

Fig.7.Snapshot of speedometer circuit board

2.4.Collision prevention system

A **buzzer** or **beeper** is an audio signaling device, which may be mechanical, electromechanical, or piezoelectric .Typical uses of buzzers and beepers include alarm devices, timers, and confirmation of user input such as a mouse click or keystroke. HC-SR04 is an ultrasonic ranging module that provides 2 cm to 400

cm non-contact measurement function. The ranging accuracy can reach to 3mm and effectual angle is < 15°. It can be powered from a 5V power supply. There are two transducers, one to transmit and one to receive. Two transducers turn out to be cheaper, since a higher voltage is needed to transmit and switching modes using only one transducer takes a lot of analog circuitry.

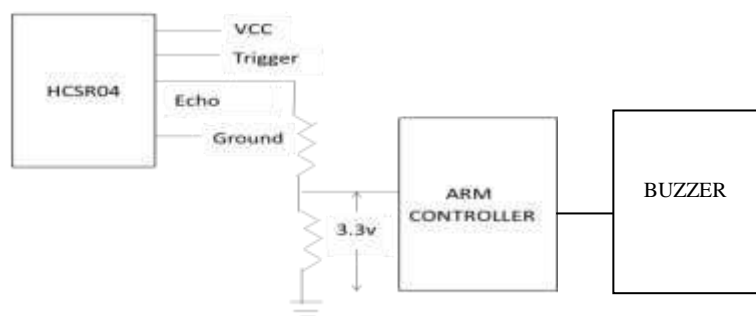

Fig.8.Circuit of collision prevention system

The ultrasonic sensors placed in the adjacent sides of the vehicle send the input to the controller when the other vehicle tends to cross the road, i.e. when the driver put the indicator to take left /right turn, the controller takes the control and waits for the input from the ultrasonic sensor placed in the adjacent sides. The ultrasonic sensor senses the obstacle from a certain distance and sends the signal to the controller. The controller receives the signal and sends the signal to the buzzer. The buzzer acts as the alarm circuit and sends the alarm signal to create an awareness to the driver. This system helps in preventing the accidents caused by the collisions

2.5.Result and discussion:

The entire system is designed and interfaced with required circuits which enables the system to prevent the accidents caused by the human's lag in response to the panic situation. The results of the proposed system with obstacle detection system and speed measurement system and brake control system is described in the following.

Obstacle detection system

The proposed system was started initially with the obstacle detection system. The selection for the sensors was a major difficult task as the system needs cost effective and most accurate sensor. The ultrasonic sensor was selected among all sensors as it gives accurate result over a range of 10cm. The major problem that had occurred during testing was it gave an inaccurate results at some instant and it was rectified later by changing the ultrasonic sensor position. After

testing, the results observed were, the system is designed with ultrasonic sensor which is very efficient and its responds quickly.

Speed measurement system

The next system designed was speedometer system. Initially hall sensor was used for measuring speed because of its inaccuracy, IR sensor was used. Hardware circuits were designed to receive the signal from sensor. Programming part for speedometer was very complex and had more errors at earlier stage but by continuous change of formulas and functions the error gets corrected and accurate data was received.

Brake control system

The next system designed was Brake control system. Two methods were used for designing namely, DC motor and relay logic . Using DC motor the system took more time to respond and it produced poor results. The relay logic gave better results and it gave quick response. Then all the system was integrated and tested under various time and weather conditions.

Collision prevention system

The collision prevention system was designed using two ultrasonic sensors .The integration of two ultrasonic sensors was very difficult since, it gave two outputs. The controller gave very slow response in reacting to the outputs. Later it is rectified by using simplified coding and the entire program for collision prevention system was integrated with the buzzer and tested under various time and weather conditions.



Fig.9.Hardware implementation of proposed system

III. CONCLUSION

Thus, the proposed system with brake control circuit and speed measurement system helps to prevent the accidents caused by the human's lag in response to the panic situation during autonomous mode of running of vehicle. The system is proposed using tri-wheeled e-vehicle. Due to increased environmental pollution, our world is chasing a dream of new green revolution. In regard to the automobile industry, electric vehicles plays a key role in maintaining sustainable environment. It

will be the best solution to energy crisis problem. It is very less in cost compared to other vehicles. It is the eco-friendly vehicle. The combined qualities of the vehicle with the proposed system helps in reducing the accidents. Added to that, the collision prevention system helps in preventing the hit from side accidents which is said to be the major cause for the increased road accidents in India during survey taken in 2018. This vehicle with integrated system will be the solution for all the problems causing accidents.

ACKNOWLEDGMENT

We extend our gratitude to **TVS motors** for having provided us with tri-wheeled vehicle to build our project successfully. We express our sincere gratitude to **ACCS** organization for having provided us with freedom k64 controller through **ARM design challenge contest**.

We are committed to place our heartfelt thanks to all our faculty members, lab technicians and friends, who played the supporting role throughout the project.

REFERENCES

1. AncyJohn , P. R. Nishanth "Real time embedded system for accident prevention" 2017 International conference of Electronics, Communication and Aerospace Technology (ICECA).
2. J.MohanKumar, RishabhMahajan, DeekshaPrabhu, DebasmitaGhose "Cost effective road accident prevention system" 2016 2nd International Conference on Contemporary Computing and Informatics(IC3I).
3. D.Selvathi,P.Pavithra, T.Preethi "Intelligent transportation system for accident prevention and detection" 2017 International Conference on Intelligent Computing and Control Systems (ICICCS).
4. Jian-XiongYang,JunzoWatada "Accident prevention system based on semantic network" 2008 International Conference on Machine Learning and Cybernetics.
5. Md.SadadMahamud, MalihaMonsur, Md.SaniatRahmanZishan "An arduino based accident prevention and identification system for vehicles 2017 IEEE Region 10 Humanitarian Technology Conference (R10-HTC).
6. GerardGibbs, HuaminJia, IrfanMadani "Obstacle Detection with Ultrasonic Sensors and Signal Analysis Metrics" in 2017.
7. S.Kodagoda, A.S.M. Hemachandra, E.Jayasekara, P.Peiris, R.L.De Silva, R.Munasinghe "Obstacle Detection and Map Building with a Rotating Ultrasonic Range Sensor using Bayesian Combination" Information and Automation, 2006. ICIA 2006.
8. Yan Peng, DongQu, YuxuanZhong, ShaorongXie, Jun Luo, Jason Gu "The obstacle detection and obstacle avoidance algorithm" 2015 IEEE International Conference on Information and Automation.
9. J.Borenstein, Y. Koren "Obstacle avoidance with ultrasonic sensors" IEEE Journal on Robotics and Automation (Volume: 4 , Issue: 2 , Apr 1988)
10. G.Bauzil, M.Briot, P.Ribes "A navigation sub-system using ultrasonic sensors for the mobile robot HILARE" Proc. 1st Int. Conf. Robot Vision and Sensory Controls, pp. 47-698, 1981-Apr.