



Chief Editor

Dr. A. Singaraj, M.A., M.Phil., Ph.D.

Editor

Mrs.M.Josephin Immaculate Ruba

Editorial Advisors

1. Dr.Yi-Lin Yu, Ph. D
Associate Professor,
Department of Advertising & Public Relations,
Fu Jen Catholic University,
Taipei, Taiwan.
2. Dr.G. Badri Narayanan, PhD,
Research Economist,
Center for Global Trade Analysis,
Purdue University,
West Lafayette,
Indiana, USA.
3. Dr. Gajendra Naidu.J., M.Com, LL.M., M.B.A., PhD. MHRM
Professor & Head,
Faculty of Finance, Botho University,
Gaborone Campus, Botho Education Park,
Kgale, Gaborone, Botswana.
4. Dr. Ahmed Sebihi
Associate Professor
Islamic Culture and Social Sciences (ICSS),
Department of General Education (DGE),
Gulf Medical University (GMU), UAE.
5. Dr. Pradeep Kumar Choudhury,
Assistant Professor,
Institute for Studies in Industrial Development,
An ICSSR Research Institute,
New Delhi- 110070.India.
6. Dr. Sumita Bharat Goyal
Assistant Professor,
Department of Commerce,
Central University of Rajasthan,
Bandar Sindri, Dist-Ajmer,
Rajasthan, India
7. Dr. C. Muniyandi, M.Sc., M. Phil., Ph. D,
Assistant Professor,
Department of Econometrics,
School of Economics,
Madurai Kamaraj University,
Madurai-625021, Tamil Nadu, India.
8. Dr. B. Ravi Kumar,
Assistant Professor
Department of GBEH,
Sree Vidyanikethan Engineering College,
A.Rangampet, Tirupati,
Andhra Pradesh, India
9. Dr. Gyanendra Awasthi, M.Sc., Ph.D., NET
Associate Professor & HOD
Department of Biochemistry,
Dolphin (PG) Institute of Biomedical & Natural Sciences,
Dehradun, Uttarakhand, India.
10. Dr. D.K. Awasthi, M.SC., Ph.D.
Associate Professor
Department of Chemistry, Sri J.N.P.G. College,
Charbagh, Lucknow,
Uttar Pradesh. India

ISSN (Online) : 2455 - 3662

SJIF Impact Factor :5.148

EPRA International Journal of Multidisciplinary Research

Monthly Peer Reviewed & Indexed
International Online Journal

Volume: 5 Issue: 4 April 2019



Published By :EPRA Publishing

CC License



**EPRA International Journal of
Multidisciplinary Research (IJMR) Peer Reviewed Journal**

WIRELESS POWER TRANSMISSION FROM SOLAR PV USING SWITCHING MODE POWER AMPLIFIER

Prabhu Raj.M¹

¹Assistant Professor,
Department of EEE ,
Dr.Mahalingam College of Engineering and
Technology,
Pollachi-642003

Anish.S²

²UG Student,
Department of EEE ,
Dr.Mahalingam College of Engineering and
Technology,
Pollachi-642003

Ashok Kumar.N³

³UG Student,
Department of EEE ,
Dr.Mahalingam College of Engineering and Technology,
Pollachi-642003

ABSTRACT

The electrical power transmission from the source to destination without any use of wires is known as wireless power transmission. Copper cables and conducting wires are not used for wireless power transfer. Wireless power transmission has a wide range of applications like charging of electric vehicles, Hybrid cars, electronic devices etc. Earlier transfer of wireless power has been achieved for charged batteries or AC source. In this paper the output from the solar panel is taken as the input to the DC-DC boost converter. The boost converter is used since the solar panels output is very small it has to be stepped up to appropriate values. The stepped up dc voltage is given to the class-E amplifier and then converted into high frequency oscillating signal. This signal is further transferred wirelessly using a transmitter and receiver coil. By achieving good magnetic coupling that exists between the transfer setup that is transmitter coil and receiver coil the power is been transferred. Later the bridge rectifier circuit converts the oscillating signal into DC before it is fed to the load.

KEYWORDS-step up converter,class e amplifier,transmitter coil,reciever coil,bridge rectifier.

I.INTRODUCTION

The process of transmitting electrical power from one place to another without the use of conducting cables is called wireless power transmission. By using this technology transmission of electrical power to remote areas without wires is possible. This can be used for applications where either an instantaneous amount or a continuous delivery of energy is needed, but where conventional wires are unaffordable or inconvenient or expensive or hazardous or unwanted or impossible. Nikola tesla demonstrated transmission of

electrical energy without wires in early 19th century by inventing Tesla coil, which was used to transfer energy wirelessly using radiative method. The wireless power transfer can be achieved by three ways which are magnetic coupling mode, electric field coupling mode and electromagnetic radiation mode. The magnetic coupling mode is classified into short range electromagnetic induction and mid-range strongly coupled magnetic resonance. The power transferred and the transfer efficiency in the case of electromagnetic induction is high but the distance to which the power is transferred is less.

In the case of strongly coupled magnetic resonance method, the power can be transferred for a longer distance with reduced efficiency when compared to short range electromagnetic induction type. The main principle in the case of electric field coupling mode is the redistribution of the surface charge on any object. The transmitter is excited with a high voltage and high frequency source to generate an alternating electric field which couples with the resonant receiver. The power transferred in this mode is less and the efficiency of the power transfer is largely affected by the surrounding medium. Lastly in the case of electromagnetic radiation, the electric energy is converted into electromagnetic energy such as laser beams or microwaves, which can be radiated over a longer distance. Then received electromagnetic energy is converted back into electric energy. With the increased distance of power transmission in electromagnetic radiation mode, the transfer efficiency is reduced.

II.OVERVIEW OF THE PROCESS

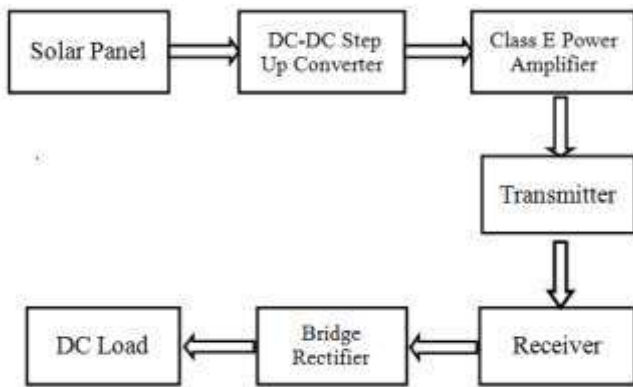

Figure 2.1 Block Diagram

The output from the solar panel is fed to the step up converter and stepped up to a certain voltage and then is amplified using a class E amplifier. The output is then transmitted using a transmitter coil and received in the receiver coil. The received energy is rectified using a bridge rectifier and then regulated using a voltage regulator and fed to the load.

III.DESIGN CALCULATIONS:

Boost Converter:

- i. Time period = $\frac{1}{10^5} = 1e-5$ seconds
- ii. Duty cycle = $1 - \frac{12}{110} = 0.90$ (or) 90%
- iii. Inductor current $I_L = \frac{0.4 * 1 * 110}{12} = 3.66$ A

iv. Inductance L = $\frac{12 * (110 - 12)}{3.66 * 10^5} = 10\mu H$

v. Capacitance C = $\frac{1 * 0.90}{10^5 * 110} = 10\mu F$

Class E Amplifier:

i. Breaking Voltage of Mosfet = $\frac{3.56 * 110}{0.9} = 435$ V

ii. Load resistance $R_L = \frac{0.577 * 110^2}{60} = 116$ ohm

iii. Capacitance C = $\frac{1}{2\pi f R * 5.447} = 162$ nF

iv. Inductance L = $\frac{1.1525 * 47}{2 * 3.14 * 10^5} = 1.72\mu H$

V.SIMULATION AND RESULTS:

BOOST CONVERTER SIMULINK:

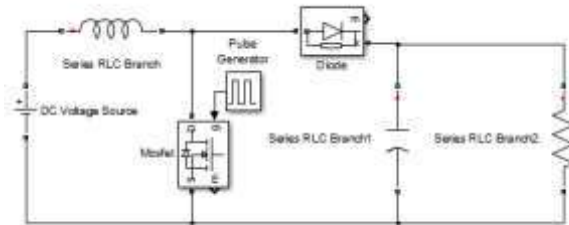

Figure 5.1 Simulink of boost converter OUTPUT WAVEFORM:



Figure 5.2 output waveform of boost converter

The input voltage of 12 V is stepped up to a voltage of 110V using the boost converter and is then amplified using a class e amplifier.

SIMULINK OF PROPOSED MODEL:

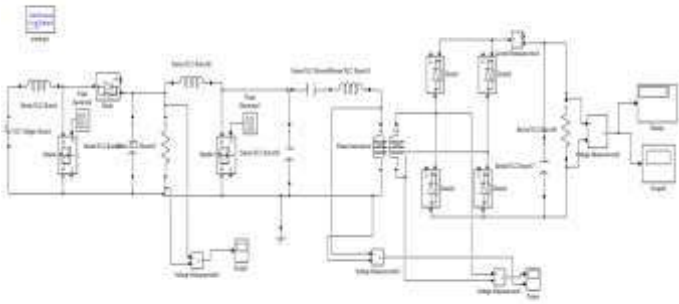

Figure 5.3 overall simulink model

OVERALL OUTPUT WAVEFORM:

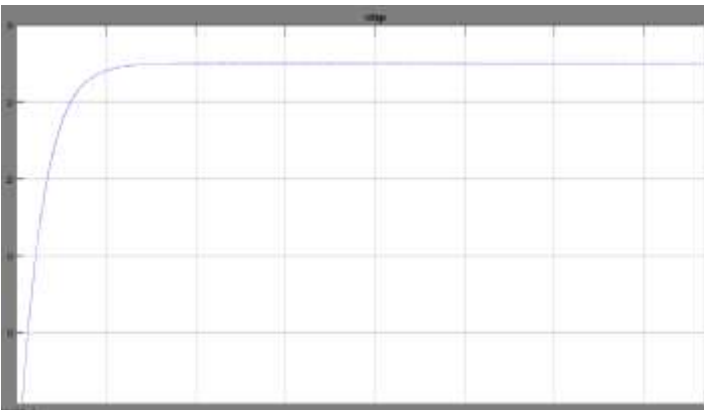

Figure 5.4 overall output waveform

Thus the output of 27 V is obtained at the load.

VI.HARDWARE SETUP:



Figure 6.1 Hardware Setup of proposed system.

VII. CONCLUSION

Thus the simulation and hardware of the proposed model is done. The input of solar panel is 12V is boosted to 120V and then fed to the transmitter and received through a receiver coil. The received voltage is 15V and the further regulated to 5V using voltage regulator and then fed to the load. The power is transferred wirelessly to a distance of 5cm and mobile is charged to a distance of 3cm. The output power is 15W.

REFERENCE

1. Qiang wang and Hong Li, "Research on the wireless power transmission system based on coupled magnetic resonances", *IEEE International Conference 2011*.
2. Q. Zhao and F. C. Lee, "High-efficiency,high step-up dc-dc converters" *IEEE Trans. Power Electron*, vol. 18, no. 1, pp. 65-73, Jan. 2003.
3. R. J. Wai, C. Y. Lin, R. Y. Duan, and Y. R. Chang, "High-efficiency dc- dc converter with high voltage gain and reduced switch stress," *IEEE Trans.Ind. Electron.*, vol. 54, no.1, pp. 354-364, Feb. 2007.
4. A. Kurs, A. Karalis, R. Moffatt, J.D. Joannopoulos, P. Fisher, M. Soljacic, "Wireless Power Transfer via Strongly Coupled Magnetic Resonances," *Science*. 2007, July 6th, Vol. 317:83-86.
6. T. Nagashima, "Analysis and design of class-E switching circuits for inductively coupled wireless power transfer systems," *PhD Thesis, University of Chiba, Japan, 2015*.