



INSTALLATION OF AUXILIARY TECHNICAL DEVICES INSIDE THE PANELS

Rakhmonov Dilmurod Khusanboyevich

Assistant of Department

“Electronics and instrumentation”

Ferghana Polytechnic Institute

Uzbekistan,

Ferghana

ABSTRACT

The main purpose of the panels is to centralize the means of controlling and regulating the operation of the unit, process plant or workshop.

KEYWORDS: *installation of devices, automation, installation of controls, boards, frame.*

DISCUSSION

Appointment and classification of shields. Automation systems shields are the link between the control object and the operator. The main purpose of the shields is to centralize the means of monitoring and regulating the operation of a unit, a technological unit or a workshop. At the same time, they serve as a supporting structure for the installation of instruments, automation equipment, supply and strapping wiring. By appointment, the shields are divided into local, aggregate, block, central and auxiliary. Instruments and controls for a part of a technological installation (an individual installation) are mounted on local boards. Basically, local shields are cupboards and are placed near the controlled object, i.e. in the production area.

Aggregate shields are intended for the installation of monitoring and control devices for one technological unit, as well as for the same type of units or technological installations located in a proper room. Such shields are usually supplied by the unit manufacturer, complete with it. Block shields are used to accommodate devices and controls for the operation of interconnected aggregates, which represent a complex installation. Central boards (control rooms) are boards on which the means of control and regulation of technological processes of a shop, a plant or a complex of technologically related industries are

concentrated. Central panels are installed in special rooms of instrumentation and automation.

Auxiliary shields are non-operational shields. They are subdivided into:

- Relay boards, on which all possible electrical equipment, elements of electrical signaling systems are placed;

- Power boards (service for supplying electricity to the instrumentation system);

- Panels with heating (small-sized), which are used when installing devices in open areas and in unheated rooms.

Block diagram of the construction of panel structures according to OST 36.13-76 Terms of panel products:

The cabinet is a three-dimensional frame on a support frame with a panel, walls, a door, and a lid installed on it.

Frame - a rigid supporting volumetric or flat metal frame, intended for installation of panels, walls, doors, covers and installation of devices, apparatus, electrical and pipe wiring, etc.

Rack - a volumetric or flat frame on a support frame.

Panel with a frame - a volumetric frame on a support frame with a panel installed on it.

The body of the control panel is a volumetric frame with installed inclined table-top, walls, doors.

Cabinet board - a cabinet with equipment, fittings, installation products and with electrical and pipe wiring prepared for connecting external circuits and devices installed on unified mounting structures, a rotary or stationary frame, installed at the facility.

Panel board with a frame - a panel with a frame with equipment, fittings, installation products and with electrical and pipe wiring, installed on unified mounting structures, a rotary or stationary frame, connection of external circuits and devices installed at the facility.

A cabinet is a rack with a volumetric frame and installed on unified mounting structures, equipment, fittings, installation items and with electrical and pipe wiring, prepared for connecting external circuits and devices installed on object.

Flat cabinet - a rack with a flat frame and installed on unified mounting structures, equipment, fittings, installation items and with electrical and pipe wiring, prepared for connecting external circuits and devices installed at the facility...

Decorative panel - a panel designed for decorative design of the upper part of panel boards with a frame, as well as for mounting elements of mnemonic diagrams.

Corner insert is an element designed to connect two adjacent panels or panels installed at an angle to each other.

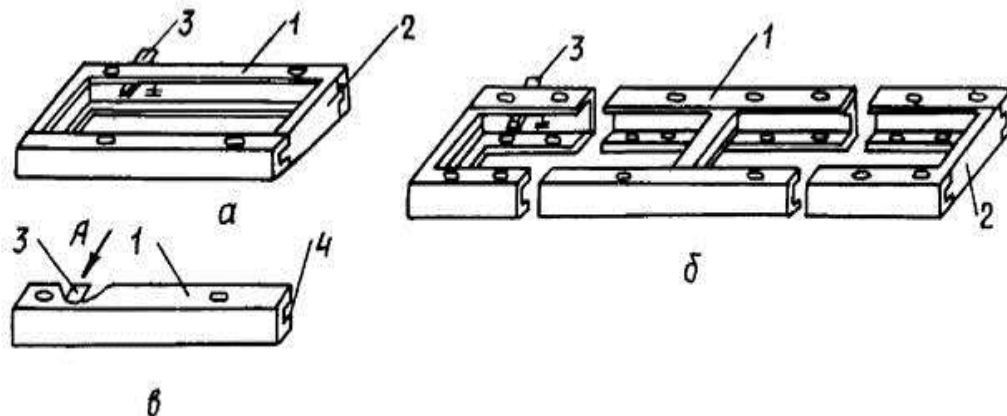

Panels with a frame are used as metal structures for panel panels with a frame. The latter are used to build dispatching and operator stations from ready-made switchboard sections.

Fig. 3. The support frame is multi-section (a), single (b), flat (c): 1-longitudinal channel, 2-

Shield designs. The main supporting structure of the boards is the frame (volumetric and flat). The three-dimensional frame (Fig. 1) consists of four struts connected by bolts with the upper and lower frames. In places of contact between frames and racks, gaskets made of plastic material are installed, closing the cracks and playing the role of a shock absorber.

On the front side of the frame, one or two channels are installed between the posts, forming a jumper for attaching the front panels. The frame parts are made of steel sheet 2.5 mm thick. The stand is made in the form of a channel with brackets welded along the edges. The frame is welded from two uprights and fastened U-shaped parts of the channel type.

The frame is flat (Fig. 2) consists of two racks, bolted to two frames. Support frames are designed for installation of panels of panel structures on them. The support frame (Fig. 3.) is a welded assembly unit of longitudinal and transverse channels. Frames are attached to the support frames, forming one-, two-, three-section racks.

C Panels with a frame are formed by assembling uniform frames on a support frame with the installation of facade panels and side walls.

channel, 3- grounding bracket, 4- sheet. Cabinets of closet panels are formed in a similar way. Cabinet boards have side panels, covers and doors.

Panel-type protective and supporting elements are rectangular box-shaped parts made of sheet steel with a thickness of 1.2-1.5 and 2.5 mm, respectively.

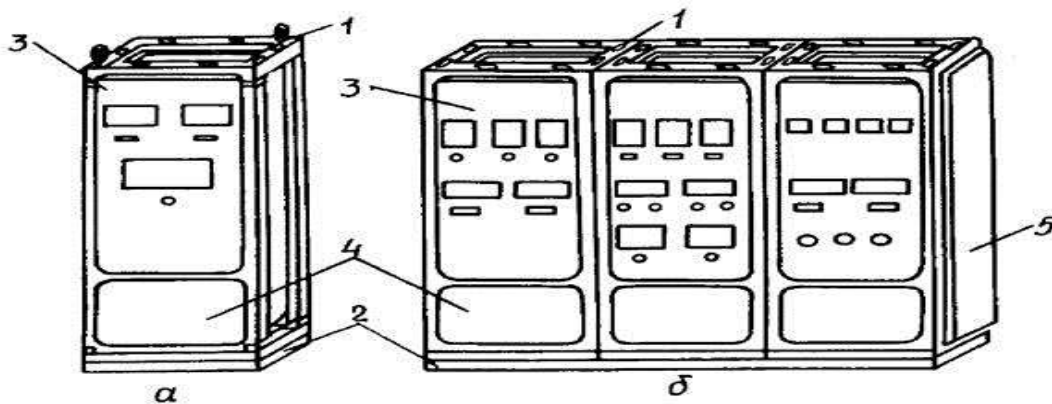

Fig. 3. Panel with frame: 1-frame, 2-support frame, 3-eyebolt, 4-panel, 5-screws connecting the frames.

REFERENCES

1. Yusupbekov N.R., Mukhamedov Sh.M., Gulomov Sh.M. *Technological process control and automation. -T. : teacher, 2011.3.*
2. Klyuev A.S. and others. *Design of automation systems for technological processes; 2nd edition. -M. : Energoatomizdat, 1990.*
3. Klyuev A.S. and other *Technique for reading automatic control and technological control schemes. 3rd edition. -M. : Energoatomizdat, 1990.*
4. Tregub and others. *Design, installation and operation of automation systems in the food industry. -M. : Agropromizdat, 1991.*
5. Yusupbekov N.R. etc., *Technological Process Management Systems. - Tashkent: teacher, 1997.*
6. Minaev P.A. *Installation of control systems and automation. 2nd edition. - M., Stroyizdat, 1990.*
7. Klyuev AS *Adjustment of automatic systems and control devices for technological processes. -M. : Energoatomizdat, 1990.*
8. Martynenko I.I. and other *Design of automation systems 2nd edition. - M.: Energoatomizdat, 1991.*
9. Emelyanov A.I. and other *Design of systems for the automation of technological processes. 2nd edition. - M. : Energoatomizdat, 1991.*
10. Mimikonov A.G. *ACS design. -M. : Higher school, 1987.*
11. *Instructions for drawing up projects for the installation of automation systems. VSN / 61-82 / Minmontazhpetsstroy. -M., 1984.*
12. Under. ed. A. V. Kalinichenko, *Engineer's Handbook for Instrumentation and Automation. Educational and practical guide. - M. : Infra - Engineering, 2008.*
13. Numonjonov S. D. *Innovative methods of professional training //ISJ Theoretical & Applied Science, 01 (81). – 2020. – C. 747-750.*
14. Kaminsky M.L., Kaminskiy V.M. *“Installation of automation devices and systems”, -T.Teacher, 1997.-304 p.*