

**SJIF Impact Factor(2021) : 8.047**

**ISI I.F.Value : 1.188**

**ISSN (Online): 2455-3662**

**DOI: 10.36713/epra2013**

***EPRA International Journal of***  
**MULTIDISCIPLINARY**  
**RESEARCH**

*Monthly, Peer Reviewed (Refereed) & Indexed International Journal*

**Volume - 7      Issue - 6      June    2021**



**I**  
**J**  
**M**  
**R**



**Chief Editor**  
**Dr. A. Singaraj, M.A., M.Phil., Ph.D.**

**Managing Editor**  
**Mrs.M.Josephin Immaculate Ruba**  
**Editorial Advisors**

1. **Dr.Yi-Lin Yu, Ph. D**  
Associate Professor,  
Department of Advertising & Public Relations,  
Fu Jen Catholic University,  
Taipei, Taiwan.
2. **Dr.G. Badri Narayanan, PhD,**  
Research Economist,  
Center for Global Trade Analysis,  
Purdue University,  
West Lafayette,  
Indiana, USA.
3. **Dr. Gajendra Naidu.J., M.Com, LL.M., M.B.A., PhD. MHRM**  
Professor & Head,  
Faculty of Finance, Botho University,  
Gaborone Campus, Botho Education Park,  
Kgale, Gaborone, Botswana.
4. **Dr. Ahmed Sebihi**  
Associate Professor  
Islamic Culture and Social Sciences (ICSS),  
Department of General Education (DGE),  
Gulf Medical University (GMU), UAE.
5. **Dr. Pradeep Kumar Choudhury,**  
Assistant Professor,  
Institute for Studies in Industrial Development,  
An ICSSR Research Institute,  
New Delhi- 110070.India.
6. **Dr. Sumita Bharat Goyal**  
Assistant Professor,  
Department of Commerce,  
Central University of Rajasthan,  
Bandar Sindri, Dist-Ajmer,  
Rajasthan, India
7. **Dr. C. Muniyandi, M.Sc., M. Phil., Ph. D,**  
Assistant Professor,  
Department of Econometrics,  
School of Economics,  
Madurai Kamaraj University,  
Madurai-625021, Tamil Nadu, India.
8. **Dr. B. Ravi Kumar,**  
Assistant Professor  
Department of GBEH,  
Sree Vidyanikethan Engineering College,  
A.Rangampet, Tirupati,  
Andhra Pradesh, India
9. **Dr. Gyanendra Awasthi, M.Sc., Ph.D., NET**  
Associate Professor & HOD  
Department of Biochemistry,  
Dolphin (PG) Institute of Biomedical & Natural Sciences,  
Dehradun, Uttarakhand, India.
10. **Dr. D.K. Awasthi, M.SC., Ph.D.**  
Associate Professor  
Department of Chemistry, Sri J.N.P.G. College,  
Charbagh, Lucknow,

ISSN (Online) : 2455 - 3662  
SJIF Impact Factor :8.047  
ISI.I.F. Value : 1.188  
DOI : 10.36713/epra2013



EPRA International Journal of  
**Multidisciplinary  
Research**

Monthly Peer Reviewed & Indexed  
International Online Journal

Volume: 7 Issue: 6 June 2021

Indexed By:



Published By :EPRA Publishing

CC License





# EPRA International Journal of Multidisciplinary Research (IJMR)

Peer Reviewed Journal || Journal DOI URL: <https://doi.org/10.36713/epra2013>

## CONTENTS

S.NO	TITLE	AUTHOR/S	PAGES
1	A NEW LOOK AT JIZZAKH WOMEN'S CLOTHING	Khakima Babaydavlatovna Davlatova	1-4
2	SCIENCE AND ART OF UZBEKISTAN AND INDIA STRENGTHENING CULTURAL TIES IN VARIOUS FIELDS AS A FORM OF PUBLIC DIPLOMACY	Sardor Ikhtiyor oglu Doniyev	5-8
3	RESEARCH ON ATTITUDES TOWARDS WOMEN IN CENTRAL ASIA	N. Djuraeva	9-13
4	TYPES OF WORLD PICTURES IN THE CONTEXT OF MODERN LINGUISTICS	Zarina Bakhtiyarovna Khojieva	14-17
5	USE OF INULINE AS A SUPPORTING SUBSTANCE IN THE TABLET TECHNOLOGY	K. S. Ibragimova, A. Sh. Khusenov, G. R. Raxmonberdiev, M. M. Shokirova	18-19
6	PUBLIC ADMINISTRATION SYSTEM IN UZBEKISTAN	Kamoliddin Mirzaakhmedov	20-25
7	WORKFORCE DESIGN AND EMPLOYEE PERFORMANCE IN THE HOTEL INDUSTRY IN KISUMU COUNTY, KENYA	David Ochieng Osir, Eglay Tsuma, Willis Otuya	26-31
8	ANALYSIS OF EXPERIENCE OF FOREIGN COUNTRIES IN ENSURING PUBLIC SAFETY <a href="https://doi.org/10.36713/epra3602">https://doi.org/10.36713/epra3602</a>	Haydarov Alisher Usmon o'g'li	32-36
9	ORGANIZATIONAL AND ENVIRONMENTAL CHANGES: A BASIS FOR CURRICULUM REDESIGN <a href="https://doi.org/10.36713/epra7241">https://doi.org/10.36713/epra7241</a>	Charl Vince L. Porlares, Emily B. Tan, PhD	37-45
10	SOCIO-ECONOMIC FACTORS BEHIND UN-SATISFACTORY PERFORMANCE OF ANGANWADI CENTERS UNDER ICDS PROGRAMME IN INDIA	Sudeshna Saha, Dr. Bikash Saha	46-53
11	ON THE PROBLEM OF LANGUAGE BORROWING (ON THE EXAMPLE OF THE RUSSIAN LANGUAGE)	Surojbek Ruzmetov	54-58
12	SATISFACTION OF MALE AND FEMALE TEACHERS IN INDIAN HIGHER EDUCATION: A REVIEW	Sapna, Anjali Gupta, Smita	59-65
13	GROUPING AND ASSESSMENT OF TOURISM AND RECREATION RESOURCES OF BUKHARA REGION	Ahmadjon Muhamadovich Mavlonov, Istat Elmurodovna Mirzoeva, Anvar Nusratovich Nematov, Charos Zarifovna Jalilova	66-68
14	AN ANALYSIS OF SERVANT LEADERSHIP IN AFRICA USING A SINGLE CASE OF THE LATE PRESIDENT DR. JOHN POMBE JOSEPH MAGUFULI IN TANZANIA	Stephen James, Dr. Faustine Kashumba	69-80

15	THE HISTORICAL ROOTS OF RELIGIOUS TOLERANCE IN UZBEKISTAN	Tashmatov Ibragimjan	81-83
16	LIFE OF THE RELIGIOUS SERVANT: AS BASIS FOR PERSONALITY DEVELOPMENT OF THE YOUTH	Orland C. Silvestre	84-90
17	RELIGIOUS VIEWS AND REPRESENTATIONS IN SAMARKAND ETHNIC CULTURE: A PHILOSOPHICAL PERSPECTIVE	Bunyod Makhmudovich Yalgashev	91-94
18	CRITICAL ANALYSES WITH THE HELP OF RECENT LITERATURE TO HIGHLIGHT THE RELATIONSHIP BETWEEN NARCISSISM AND ADDICTION TO SOCIAL MEDIA/NETWORKING	Huzefa Mandasaurwala	95-103
19	THE SEMANTICAL STRUCTURE OF LANGUAGE UNITS EXPRESSING THE LEVEL OF A SYMBOL <a href="https://doi.org/10.36713/epra1683">https://doi.org/10.36713/epra1683</a>	Nilufarkhon Ravshanovna Makhmudova	104-107
20	THE CONTENT OF YOUTH EDUCATION IN KARAKALPAK FAMILIES BASED ON FOLKLORE <a href="https://doi.org/10.36713/epra7273">https://doi.org/10.36713/epra7273</a>	Amangul Doskhodjaeva	108-113
21	AN ICONOGRAPHY OF STIGMATIZED EXISTENCE: EFFECTS OF PANDEMIC COVID-19 AND LOCKDOWN ON MENTAL HEALTH	Tanmoy Mandal	114-118
22	A STUDY DURING COVID ON DIGITAL DEVICES DEPENDENCY & IT'S IMPACT ON HEALTH	Sajul Ramachandran, J Saran Prakash, Ron Soj Varghese, Shaaheen Shareef, Sreehari K.S Shikha Upadhyay	119-124
23	SMART ROBOTIC SHOPPING CART USING RADIO FREQUENCY IDENTIFICATION	DR. Siva Subramanian S, Ph.D. Shivanjali Sivakumar, G. Soniya	125-131
24	A STUDY ON CUSTOMER AWARENESS TOWARDS PRADHAN MANTRI BHARATIYA JAN AUSHADHI KENDRA'S WITH REFERENCE TO TIRUPUR DISTRICT	Dr.R.Rajasekaran, Dr.K.P.Balakrishnan, Mr.Barath Chellah	132-135
25	A STUDY ON DIVIDEND POLICY OF TAMILNADU NEWSPRINT AND PAPERS LIMITED WITH SPECIAL REFERENCE TO 2014-15 TO 2019-20	Dr.C.RAJA	136-141
26	BLOOD BANK SYSTEM BASED ON DYNAMIC LOCATION UPDATION	Ankit Kumar Saini, Avneesh Yadav, Harshit Garg, Utsav Chhaparia	142-149
27	Effect of Nickel and Chromium Metals on the Development of Rhizobial Colonies in Pisum Sativum Rhizosphere	Pandey.D, Kumari.A	150-156
28	AN EXAMINATION OF SOCIO-ENVIRONMENTAL PROBLEMS FACED BY AGRO-INDUSTRIES AND NEIGHBOURHOOD SETTLEMENTS IN CAMEROON: THE CASE OF CAMEROON DEVELOPMENT CORPORATION (CDC) IN FAKO DIVISION, SOUTH WEST REGION	Norah Aziamin Asongu Ph.D, Ngoe Fritz Eseokwea Ph.D	157-168

	<a href="https://doi.org/10.36713/epra7347">https://doi.org/10.36713/epra7347</a>		
29	ASSESSMENT THE MORAL DON'TS IN THE NEWS SERVICES OF LOCAL TVS IN BAGHLAN <a href="https://doi.org/10.36713/epra7287">https://doi.org/10.36713/epra7287</a>	Ansarullah Omari	169-185
30	CONTEMPORARY ART SCENARIO IN THE STATE OF ANDHRA PRADESH <a href="https://doi.org/10.36713/epra7344">https://doi.org/10.36713/epra7344</a>	Dr. K. Mrutyunjaya Rao	186-192
31	FINANCIAL STRESSORS AND TEACHERS' AWARENESS ON FINANCIAL LITERACY AND SURVIVAL PLAN	Anarose M. Blanza	193-207
32	SIMILARITIES BETWEEN EMPEROR CHANDRAGUPTA II (VIKRAMADITYA) AND EMPEROR JALALUDDIN MUHAMMAD AKBAR <a href="https://doi.org/10.36713/epra7289">https://doi.org/10.36713/epra7289</a>	Rajesh Sonkusare	208-210
33	OPTOELECTRONIC DEVICE FOR REMOTE TEMPERATURE CONTROL OF SANITARY UNITS <a href="https://doi.org/10.36713/epra7317">https://doi.org/10.36713/epra7317</a>	Sirojiddin Fayozovich Ergashev, Kuchkarov Akmaljon Axmadaliyevich, Mamasadikova Umida Yusupjonovna	211-215
34	ANALYSIS COMPARATIVE OF FEMINIST RESEARCHES <a href="https://doi.org/10.36713/epra7341">https://doi.org/10.36713/epra7341</a>	Aziza Zoirova, Raima Shirinova	216-220
35	STUDY OF YOGA AWARENESS FOR PHYSICAL & MENTAL FITNESS AMONG THE POST GRADUATE STUDENTS IN PURULIA DISTRICT DURING THE PANDEMIC SITUATION OF COVID-19	Kunal Karmakar, Dr. Laxmiram Gope	221-226
36	AN EFFECTIVE ASSESSMENT OF DEEN DAYAL UPADHYAY GRAMEEN KAUSHALYA YOJANA (DDU-GKY) IN PROVIDING SKILL TRAINING PROGRAMME FOR YOUTH: A STUDY OF HARYANA STATE <a href="https://doi.org/10.36713/epra7381">https://doi.org/10.36713/epra7381</a>	Vaibhav Verma, Dr. Pradeep Singh Chauhan	227-233
37	BENCHMARKING OF STRATEGIC PERFORMANCE MANAGEMENT SYSTEM (SPMS) IN STATE UNIVERSITIES AND COLLEGES IN ON SPMS OF LAGUNA STATE POLYTECHNIC UNIVERSITY	Rina J. Arcigal, Ed.D.	234-241
38	DESIGN FEATURES OF THE GRATE CLEANERS COTTON - RAW FROM A LARGE LITTER	Nodira Mirzakulova, Odil Turaev	242-246
39	MICROSPPONGES - A NOVEL DRUG DELIVERY SYSTEM	Mr. Pravin Tryambak Netkar, Miss. Kaveri Wagh, Mr. Shivam Ravindra Patil, Mr. Utkarsh Prakash Metha, Miss. Harshali Ravindra Thakare, Miss. Fayza Qureishi,, Miss. Shraddha Ravindra Chavan	247-256
40	THE RISE OF OTT PLATFORM: CHANGING CONSUMER PREFERENCES	Ms. Kaneenika Jain	257-261
41	ELECTROMAGNETIC FIELD OF LOW FREQUENCY AND COMMUNICATION SYSTEMS IN MICROORGANISMS	Bakhodir Mukhamadiev, Shurangiz Kasimova, Nodirabegim Kasimova	262-264
42	AN UNINTENDED DISEQUILIBRIUM: IMPACTS OF COVID-19 AND LOCKDOWN	Tanmoy Kumar Bhattacharjya	265-269



	ON MENTAL HEALTH, WELL-BEING AND THE STRIVE OF MANKIND		
43	DEVELOPMENT OF ECOLOGICAL TOURISM IN UZBEKISTAN	Atadjanova Sayyora Melisovna	270-273
44	A STUDY ON CHANGE MANAGEMENT AT COMMERCIAL TAXES DEPARTMENT	Amtul Wahab	274-280
45	ENTREPRENEURSHIP EDUCATION AS A TOOL FOR EMPLOYMENT GENERATION AMONG NYSC CORPS MEMBERS IN IBADAN NORTH, OYO STATE	Adedapo AA, Nzei IF	281-297
46	PERSONALITY TRAITS EFFECT ON WRITTEN AND PERFORMANCE TASKS: BASIS FOR INTERVENTION PLAN	Pazangelene A. Villaruben	298-307
47	COVID 19 PANDEMIC: EFFECT ON ACADEMIC PERFORMANCE OF 4P'S GRADE 7 STUDENTS	Clarissa Q. Villamater	308-319
48	CONCEPT AS A SYNTHESIS OF THE ELEMENTS OF LANGUAGE AND CULTURE <a href="https://doi.org/10.36713/epra7401">https://doi.org/10.36713/epra7401</a>	Popov Dmitry Vladimirovich	320-325
49	SAVITRIBAI PHULE THE FIRST LADY TEACHER AND SOCIAL REFORMER IN NINETEENTH CENTURY OF INDIA <a href="https://doi.org/10.36713/epra7439">https://doi.org/10.36713/epra7439</a>	Sourav Chandra Garaian, Dr. Subir Sen	326-329
50	STUDY ON SUSTAINABLE CARPET TILE FLOORING IN 5-STAR HOTEL OF INDIA <a href="https://doi.org/10.36713/epra7447">https://doi.org/10.36713/epra7447</a>	Ayushi Jain, Ar. Sweta Choudhary	330-337
51	HUMAN RESOURCE PLANNING IN AN INDIAN CEMENT INDUSTRY: A DIOGNOSTIC STUDY <a href="https://doi.org/10.36713/epra7432">https://doi.org/10.36713/epra7432</a>	Ms. Jeevana Chitreddy, Prof.G.L. Narayanappa	338-341
52	PARENTAL INVOLVEMENT IN HOME VISITATION: ITS RELATION TO STUDENTS PERSONAL DEVELOPMENT AMIDST THE PANDEMIC <a href="https://doi.org/10.36713/epra7392">https://doi.org/10.36713/epra7392</a>	Emily Christine O. Mañosca	342-352
53	A REVIEW ON TRIGONELLA FOENUM- GRAECUM ACCORDING TO TRADITIONAL SYSTEMS OF MEDICINE	MMM.Nifras, JF.Fatheena, AM.Muthalib	353-356
54	DETECTING DIFFERENTIAL ITEM FUNCTIONING IN 2019 BECE BASIC SCIENCE MULTIPLE CHOICE ITEMS ADMINISTERED IN SCHOOLS IN RIVERS STATE, NIGERIA <a href="https://doi.org/10.36713/epra7431">https://doi.org/10.36713/epra7431</a>	Dr. Wokoma T. Abbott.	357-365
55	EFFECT OF CORPORATE COMPANIES IN INDIA POST COVID	Ms. Parul Bhargava	366-370
56	ASSESSMENT OF DISASTERRISK REDUCTION MANAGEMENT OF PUBLIIC SCHOOLS IN LUCBAN DISTRICT	Arcanel F. Perez	371-375
57	A STUDY ON CONSUMER BUYING PREFERENCES OF CARS WITH REFERENCE TO SELECTED CITIES FROM TELANGANA AND ANDHRA PRADESH	Dr. Shaik Shamshuddin, Dr. T.Venkateswarulu	376-385
58	ACT EAST POLICY: A MEANS FOR	Dr. Seram Bhogendra Singh	386-389

	SUSTAINABLE DEVELOPMENT IN NORTH EAST INDIA		
59	A COMPARATIVE STUDY OF EFFECTIVENESS OF ELEARNING DURING COVID 19: EVIDENCE FROM ERNAKULAM AND IDUKKI DISTRICTS OF KERALA	Anusree V Nair, Siby K M	390-400
60	THE SOCIAL CONTENT AND VALUE OF THE PHENOMENON “FREE TIME”	Farrux Rustamov Rustam ogli	401-404
61	FIGHTING AGAINST POVERTY: HISTORY AND FATE	Kholmurodov Nozimjon Kosimovich	405-408
62	A STUDY ON FINANCIAL PERFORMANCE ANALYSIS OF HDFC BANK LTD	Mr. S. Muruganatham, Mr. S. K. Nidish	409-411
63	SOCIO-PHILOSOPHICAL PROBLEMS OF DEVELOPMENT OF ECOLOGICAL CULTURE OF UZBEK PEOPLE	Yuldasheva Diloram	412-414
64	TRADITIONAL ETHNOVETERINARY PRACTICES FROM SATPUDA FOREST REGION OF BURHANPUR DISTRICT MADHYA PRADESH, INDIA	Dr.Zahid Hasan Jafri, R. M. Bagul Prof.Azhar Uddin	415-419
65	EASIER (EXECUTABLE ACCESS TO STATISTICS FOR INTERACTIVE AND EFFICIENT RESEARCH) <a href="https://doi.org/10.36713/epra7462">https://doi.org/10.36713/epra7462</a>	Ferdie S. Ching, 2Dr. Merylyn D. Juacalla	420-431
66	A REVIEW ON MERGER OF COMMERCIAL BANKS IN INDIA: ITS IMPACT, PROS AND CONS	Dr. Sowmya Praveen K, Dr. C.K. Hebbar	432-435
67	APPLYING STATISTICAL TOOLS TO STUDY FOCUSES ON CONSUMERS BUYING BEHAVIOUR TOWARDS ONLINE SHOPPING: WITH REFERENCE TO VIZIANAGARAM AND SRIKAKULAM DISTRICTS	Dr. K Srinivas Rao	436-441
68	SHAKESPEARE CRITICISM; DR JOHNSON CONTRIBUTION TO SHAKESPEARE CRITICISM	Mr. Krishnakant Patil	442-444
69	EFFECT OF USE OF INTERNET ON ADOLESCENTS MENTAL HEALTH DURING COVID-19	Ridhee Agarwal , Navya Bajpai Mansi Patel	445-453
70	INDUSTRY AND CORPORATE SOCIAL RESPONSIBILITY IN INDIA <a href="https://doi.org/10.36713/epra7493">https://doi.org/10.36713/epra7493</a>	Dr. K.Somasekhar	454-457
71	A STUDY ON FLUCTUATIONS OF INDIAN CURRENCY WITH RESPECT TO SELECTED FOREIGN CURRENCIES	Amtul Wahab	458-469
72	ARCHAEOLOGICAL MONUMENT OF UCHTEPA-BULAKMAZAR - AS A NEW TOURISM SITE OF NAMANGAN REGION	Asqarorov Qahraman, Tukhtasinov Dilshot, Rahmonov Ulugbek	470-472
73	ORGANIZATION OF GARDEN PLOT SERVICE CLUSTERS – DEMAND OF PERIOD	Mahkamov Ibroyim, Shakhobov Hamidjon Mukhamadovich	473-477
74	THE PROBLEM OF TRANSLATION OF PHRASEOLOGICAL UNITS IN THE LEARNING ENGLISH	Akbarova Mohinur Alisher qizi	478-480

75	THE CONCEPT OF NATURE AND HEROES IN "ROCKS ALSO CRY"	Abdurashid Abdurakhmonov	481-483
76	REFLECTION OF MODERN PROBLEMS IN POETRY (ON THE EXAMPLE OF AMIR KHUDOIBERDI'S WORK)	Manzura Urakovna Namazova	484-488
77	AN IMPORTANT SOURCE ON THE HISTORY OF AMIR TEMUR	Zubayda Khamidovna Yuldosheva, Jumaeva Shohida	489-490
78	SLANG AN INDEPENDENT PHENOMENON IN THE SYSTEM OF SOCIAL DIALECTS	Maya Erkinovna Tursunova	491-493
79	COMPARISON OF CHILDREN'S INTELLECTUAL DEVELOPMENT WHO LIVE IN RURAL AND URBAN AREAS	Nilufar Sherkuzi kizi Yuldasheva	494-497
80	AUDIT COMMITTEE CHARACTERISTICS AND AUDIT REPORT LAG IN NIGERIA INSURANCE COMPANIES	Ovbiebo, E.O.	498-505
81	WHISTLE-BLOWING AS A FRAUD PREVENTION STRATEGY IN NIGERIA	Izevbigie, D.P.I., Omozusi, O.F.	506-512
82	SCOPE OF MENTORING IN NURSING - A REVIEW	Ms. Beulah Jasmine Rao, Dr. Ashok Dhanwal	513-514
83	Effect of Different Animal Organic Manures on the Biometric and Nutrient Parameters of Coriandrum sativumL <a href="https://doi.org/10.36713/epra7522">https://doi.org/10.36713/epra7522</a>	Maria Puspham Grace.M, Rajithra.R, V.Illakkiya, Dr. B. Dhanalakshmi	515-532
84	A STUDY ON CONSUMER BUYING BEHAVIOUR TOWARDS SMARTPHONES WITH SPECIAL REFERENCE TO TIRUPUR CITY	Mr. S. Muruganantham, Mr. S. Naveen	533-536
85	NOBEL PRIZE IN CHEMISTRY, 2020: THOUGHTS AND IMPLICATIONS <a href="https://doi.org/10.36713/epra7399">https://doi.org/10.36713/epra7399</a>	Agnita Kundu	537-540
86	CROP INSURANCE: A PATH TO DEVELOPMENT FOR GREEN INDIA <a href="https://doi.org/10.36713/epra7507">https://doi.org/10.36713/epra7507</a>	Dr. Vinod Kumar Dave	541-548
87	GOING AWAY AND COMING BACK: JOURNEY OF CHANU IN MONICA ALI'S BRICK LANE	Dr. Jyoti Rana	549-552
88	A STUDY OF COVID-19 IMPACT ON THE EDUCATION SYSTEM	Mr. Sushil Bhimrao Bansode, Miss. Sonal B. Bansode, Miss. Meghana B. Bansode	553-558
89	A SURVEY ON DATA ANALYSIS APPROACH FOR EFFECTIVE CONTAINMENT TOWARDS PANDEMIC INFECTIONS USING NEURAL NETWORKS <a href="https://doi.org/10.36713/epra7553">https://doi.org/10.36713/epra7553</a>	Anix Mary Javitha. A , Dr, Mary Livinsa. Z	559-563
90	CHILD WELFARE: A REVIEW BASED ON SOCIAL DEVELOPMENT PERSPECTIVE <a href="https://doi.org/10.36713/epra7527">https://doi.org/10.36713/epra7527</a>	Ishita Kapur	564-570
91	An Anthropological Approach to the Use of Medicinal Plants in the Treatment of Diseases: The Case of King Grass (Ageratum Conyzoides) in Batibo Subdivision in North West Region of Cameroon <a href="https://doi.org/10.36713/epra7496">https://doi.org/10.36713/epra7496</a>	Mukum Cenotar Engwari, Ngoe Fritz Esekwea (PhD), Achu Frida Njiei (PhD)	571-580





## A NEW LOOK AT JIZZAKH WOMEN'S CLOTHING

**Khakima Babaydavlatovna Davlatova**

*Master Student, Methods of Teaching Social Sciences and Humanities (History),  
Jizzah State Pedagogical University,  
Uzbekistan*

---

### ABSTRACT

*This article discusses Jizzakh women's clothing. In women's clothes traditional elements are saved among older population, less saved among young population and completely saved in ritual clothes. The composition and cut of clothes had some peculiarities in different age groups.*

**KEY WORDS:** *Jizzakh, women's clothing, ritual clothes, traditional elements*

---

### INTRODUCTION

Traditional women clothes consists of dress — shirts and wide trousers lozim, a few kinds of overcoats, such as robes mursak, tun, beshmet or camisole. For going outdoors, women had worn special head shawls, called yashmak, with face covering net — chachvan, chimbat. Different kinds of shawls were used as headgear. Footwear had consisted of ichigi (mahsi) and rubber or leather galosh. Clothes sets were added with jewelry of local Uzbek craftsmen. Traditional body clothes had consisted of dresses of tunica form — kuylak and wide trousers — lozim.

**Dress.** Dress was long, reached ankles, with strait or widening figure. Neckband cut of girls dresses was made horizontal and was sewed with frame of fabric of another colour of band on the edges. Neckband was fastened with stripe of the same material or with single button on the shoulder. Married women had worn dresses with vertical cut, which was made in the middle of chest with length about 25 centimeters and were fastened with stripes of fabric, buttons or brooch. In Bukhara and Samarkand regions, edges of neckband with vertical cut were embroidered with peshkurta — frame of golden embroidering — and decorated with embroidering. Sleeves were made strait and long, covering hands. In the end of 19th century, after Tsar Russia had conquered Central Asia, new dresses with standing neckband had appeared. Later, those dresses were decorated with pleated patterns. Standing neckband with vertical cut, covered with slat became popular in Turkestan (first in cities, later in all

regions). It was known as Tatar nuga eka and dresses with standing sleeve were called as kozoki kuylak in Zaravshan valley. Young women, before birth of first child had worn dresses with standing sleeve — parpara, decorated with teeth (in a form of triangles with sharp part up) or with pleating. Such standing neckband was usual for dresses of Uzbek women. In the end of past century, dresses with cut coquette kukrak burma had appeared and those dresses soon had had taken place in women wardrobe. Nowadays those dresses are main form of traditional costume. Dresses with standing neckband and sleeves with cuffs were also popular. Dresses with vertical cut or with standing sleeve without pleating were worn only by old women. Dresses with narrow and long sleeves, with narrow embroidered stripe between elbow and wrist were also popular. In old times cut was made in the middle of that stripe for hands, ends of sleeves were wrapped and such dresses could be found in Khorezm oasis.

Nowadays, no cuts are made on sleeves of dresses and that stripe carries only decoration meaning. Indoors women had worn one dress, in cold time — two. Rich women had worn three dresses simultaneously in holiday times. And sleeves of those dresses had identical width, but non-identical length, so embroidered ends of sleeves can all be seen. To show its' richness, women had taken a few dresses and changed it the period of visit. The quantity of simultaneously worn dresses in Bukhara and Samarkand had reached seven. The bigger amount of dresses, the richer its' owner was. That was done by young women after wedding. Often women worn



body shirts *ichki kuylak*, made from white cotton fabric. The length of dresses was different. Old women had worn dresses, reaching ground and young — shorter ones. Wide trousers. Second main part of women costume — dense wide trousers *lozim*, pinched on the waist with a belt, placed in the upper edge of the wide trousers. Often wide trousers were made from two fabrics: lower part, visible under the dress from more expensive material and upper part (from the middle of hip to the top) from simple and not expensive fabric. The bottom of trousers was sewed with narrow embroidered frames *jiak*, ends of which had formed brushes. The width and length of trousers differed. In the cities, suburbs and villages all women worn long trousers, nowadays it is worn by old women, young women — shorter and narrowing ones. Robes.

**Chopon** — quilted robes of *tunica* style robes, slightly similar to men style of robes was used as upper women's clothes. The neckband of women's robe, more open and wider wasn't embroidered or sewed, ends of women's robes haven't matched. Sleeves were shorter, but wider than men's robes. Women quilted robes of Khorezm women are very interesting. Hand stitching was substituted with narrower machine stitching and there was a horizontal cut on the level of elbow. The end of sleeve was usually hidden not to mess with working procedures. Besides of quilted robes, in the summer time, women in Zaravshan valley had worn *delegay* — non-quilted robe. Women of Samarkand and Bukhara valleys had worn light, long, unfastened robes — *rumcha*, with narrow and short (to the wrist) sleeves and cut frame. Those robes were worn as upper outdoor clothes. By the end of 20th century, women robe became non-popular and was worn only by old women. Robe was substituted with *camisole*. Robe wasn't the only kind of women overcoat. There were special kinds of robe — *mursak*, quite popular in Uzbekistan and known under different names: *mursak* — in Tashkent, *misak* — in Khorezm, *munisak* or *kaltacha* — in Samarkand, *munisak* or *mursak* — in Fergana, *kaltacha* — in Bukhara and *Shahrisabz*.

The difference between *mursak* and robe — the absence of neckband. Fabric, under sleeves was gathered in small groups, ends of it was wider due to additional wedges, one end had covered another as in robes, sides of *mursak* had cuts. *Mursak* was sewed on lining and fastened, winter *mursak* was quilted. In Tashkent sleeves of *mursak* were slightly shorter, than sleeves of original robe (until second part of 19th century) Later sleeves of robe were sewed to the elbow — *tirsak*, and the name *tirsak eng* (elbow sleeve) is based on that. Long sleeves of it were taken out. In Samarkand narrow sleeves of *mursak* had reached hands, in Bukhara and Kashkadarya *mursak* was worn with wide sleeves lower elbows, showing nice sleeves of shirt. In Khorezm *mursak* differed

from robe only with sleeves. 5 - 3820 65 In old times *mursak* was regular women outdoor clothes. To the beginning of 20th century it was fastened with *kushak* and was worn only for mourning over diseased person. But many women of older generation worn *mursak* (without *kushak*) on the wedding or on the visit (*Samarkand*).

In Tashkent, from beginning of 20th century, *mursak* wasn't worn, but it was kept by all women to cover dead ones. So, from the beginning of 20th century in Tashkent, *mursak* had lost its' meaning as clothes and was used in burial ceremonies. So, women clothes set includes not robe, but *mursak* — traditional unfastened clothes, later ritual, clothes for sacred customs. After conquest of Central Asia by Russia new forms of clothes began to fill this land: *camisole* — *kamzur*, *kamzul*, *pesmet*. Those were the robes with short and narrow sleeves, with cut frame and turn-down collar, sometimes with half-belt, side pockets. Often *camisoles* were made from bright striped *bekasam* or colour velvet, plush, imported materials. That period was marked with appearance of short sleeve-less shirts — *nimcha* (*Tashkent*), *kamzur* (*Fergana valley*). It was worn under *camisole* or over dress. It was mostly made of dark velvet or plush. Girl sleeve-less shirts were made of black satin with embroidering on hem. Those shirts became the essential part of national women costume.

**Yashmak**. Was compulsory part in women traditional costume and was used as outdoor clothes for women — city women and rich village women. Wearing of *yashmak* was regulated by custom, etiquette and religion, knowledge of which was given from childhood. *Yashmak* was a big and wide robe with long and narrow fictional sleeves. Those sleeves were placed on the back and fastened together. They were called as *sovchok* and purely hidden the figure of women from head to toes. The face of woman was hidden with thick rectangular net *chachvan*, *chimbata*, made from black horse hair, embroidered with black fabric from all sides, or decorated with contour embroidering or machine made ornament.

Net was decorated with colour beads, stringed on hair, as protective symbol. The history of *yashmak* is long and difficult. The word *faranja* (distorted *paranja* (*yashmak*)) from Persian language means dress. *Faranji* was created in Egypt and from there was spread to other Eastern countries. In Central Asia with *Sheybaniy* ruling period (16th century) *faranja*-robe was clothes of scientists. In India and Central Asia with *Babur* and *Timurids*, *faranja* was the overcoat of scientists, state officials and clergy. The word *faranja* was used for both men and women clothes. Central Asian *yashmak* has ancient prototype. Those expensive clothes had transformed in feudal period, changing in accordance with new time, yet saving its old original base. So, *yashmak* of Central Asian women was based on



ancient faranji — holiday women robe, worn as overcoat. In 16 century long and non-comfortable sleeves became decorative details, and completely lost any practical meaning in 18th century and were transformed in long stripes, sewed as real sleeves and fastened together on the back. In the times of later feudalism the meaning of yashmak had changed. It had hidden women from sights.

Wearing of yashmak had matched the principles of Islam. That 66 religion had demanded the covering of face and figure of women. In the process of life changing in 20th century, yashmak had lost its meaning. The appearance of chachan, chimbat (distorted chashi-band — eye-band) firstly wasn't connected with yashmak. The custom to cover face, popular on the East, was mentioned in 15th century. But, that tradition is older and had belonged to ancient Mongol customs. It is interesting that making of chachvan in 19th — 20th centuries was carried by nomadic gypsies — luli. Headgear. Most traditional women headgear — square or rectangular shawl — rumol, which could be twisted in many ways. In Bukhara people had worn big shawls — rido, in Fergana valley — kalgay, in Khorezm — silk shawl — rumol. Favorite head shawls of women were shawl of Russian production — silk with embroidered flowers of the same colour — farang rumol or with bouquet of flowers in the corners and round rosette in the center — chorgul rumol, gauze — halil or halil rumol and cashmere with flower ornament — shol rumol. More rich women had worn shawl, sewed with silver or gold tinsel in holiday times. It was imported from Russia or from India via Afghanistan. In usual days head was covered with shawl of white muslin — doka, sometimes decorated with embroidering.

Youth had mostly worn tubeteyka — duppi. In old times, women worn cap instead of tebeteykas, and wrapped shawls or chalms over it. Women's cap kulta, kiygich were sewed high soft base, fully covering head. There was a small hole with hair bag made on the top of cap in a form of rectangular piece of fabric. Many Uzbek women had sewed it in a form of beg whole and strings hair through it. Old women cap had differed from new one with absence of hair bag. Women of rich families had mostly worn kaltapushak with golden sewing. Embroidered tubeteykas became popular by the beginning of 20th century. In old times main form of women headgear was salla-chalma. In Samarkand women ceased to wear chalms in the middle of 20th century, in Tashkent and Andijan region — in the last quarter of past century. It was saved by nomadic tribes in changed form and still exists. The majority of women had worn it over special headgear — lachak. Lachak had fully outlined the face and covered chest. Some groups of Uzbek and especially in the delta of Amudarya had made lachak in a form of piece of fabric, worn on head with back part of lachak was

going down the back and front part (was shorter) had hidden shoulders and part of chest. Special cut was made for women face. It was tightly fitted with chin (not covering ears) and was closed with short robe, worn over it — kulta. Lachak was similar to Kazakh, Karakalpak women headgear kimichek. Lachak was mostly made of cotton fabric karbas. In Samarkand it was made of longitudinal piece of fabric. Lachak wasn't worn in South Khorezm, but while wrapping chalm, one loop was putted on the chest and it had lined the chin, bordering the face.

Among women of suburbs of Bukhara, Amudarya delta and karluk tribe, headgear kopdon, kasava and shah-bosh were very popular. Nowadays most Uzbek do not wear old headgear. Shawls of different materials, colours and sizes are dominating now. Ways of wrapping of shawls had also changed, those ways do not show the family and social status of women. Shawls are wrapped easily and with comfort. Only women of older 67 generation have shawls of white muslin doka, which are worn, twisted under chin and ends putted on shoulders. In Fergana valley special headgear — rumol, shawl of square form, bended diagonally and placed on the head with durracha — special small shawl of black or dark colour worn over first one was very popular. It was placed on the forehead, end were placed behind the back of the head, crossed, placed again on the forehead and tied up, or ends were placed in the folds of shawl. Narrow piece of white fabric loki was tied up to that shawl. Ends of loki were locked behind. In Bukhara loki was substituted with long piece of gauze. Nowadays rumol and durracha are worn by women of regions of Fergan valley and some villages of Tashkent region. Rumol was substituted with fabric made shawls, durracha — shawls of smaller size. Women and daughters of officials had worn golden sewed forehead bands peshobabayd and expensive golden sewed caps telpak with sharp end.

**Footwear.** There is saying that enemy first looks at feet, friend at head. Footwear was very important in Central Asia. Women footwear was different. In cities and villages, women mostly worn ichigi with soft base and high heels for wrapping of wide trousers. Ichigi had been very light and comfortable footwear, suitable for Central Asian conditions. Ichigi were worn with leather shoes kavush. Rich people had usually worn iroki mahsi — ichigi with embroidered kavush. In winter times, people had worn wooden shoes — hakkar kavush, egoch kavush on three legs.

## REFERENCES

1. Jumanazarova, D., & Davlatova, H. (2021). *Customs Of Population In Jizzakh Oasis Associated With Chilla. The American Journal of Interdisciplinary Innovations and Research*, 3(04), 63-66.



2. Davlatova, K. (2021). *Forish Tajiks: Territorial Location And Traditions. The American Journal of Social Science and Education Innovations*, 3(03), 338-343.
3. Doniyorov, A., Kariev, A., Aminov, H., & Karimov, N. (2021). *The Level of Study of the Religious Image of Mavarounnahr in the IX-XII Centuries. Journal of Contemporary Issues in Business and Government*, 27(1), 413-423.
4. Omonov, Q., & Karimov, N. (2020). *Importance Of Ancestral Heritage. The American Journal of Social Science and Education Innovations*, 2(09), 196-202.
5. Odilov, B. A., & Karimov, N. R. (2020). *ANALYSIS OF TARGETED RESEARCH IN 20-30 YEARS OF THE XX CENTURY. PalArch's Journal of Archaeology of Egypt/Egyptology*, 17(6), 8887-8893.
6. Karimov, N., & Doniyorov, A. (2019). *Conflicting Views Regarding the Hadiths. IJITEE, ISSN, 2278(3075)*, 2090-2094.
7. Akchayev, F. (2020). *The Pilgrimage and traditions of Jizzakh valley realating to Chillax. Архив Научных Публикаций JSPI*.
8. SAIDAZIMOVA, U. T. (2021). *The issue of two women in the korean art world. Journal of Contemporary Issues in Business and Government*, 27(3), 303-308.
9. Turakhanovna, S. U. (2020). *The Issue of Literary Heroism in Korean Literature. Solid State Technology*, 63(6), 1779-1785.
10. Saydazimova, U., & Murodova, D. (2021). *In Lee Bom Son's Story "Stray Bullet", the Issue of the Negative Consequences of the Civil War is Highlighted. Psychology and Education Journal*, 58(1), 1138-1144.
11. Khudoyberdiyevich, D. A., & Ugli, O. B. A. (2019). *Ethnographic researches on irrigated agriculture and collective land cultivation of the Uzbek people (In the example of 20-30s of XX th century). International Journal of Innovative Technology and Exploring Engineering*, 9(1), 3645-3649.
12. Lapasovich, M. O., Nematovich, N. O., Yakubovich, Z. B., Rustamovich, U. M., & Tolipov, F. (2020). *HISTORICAL AND ETHNOGRAPHIC CHARACTERISTICS AND SOCIO-SPIRITUAL FACTORS OF VISITING TOURISM IN UZBEKISTAN. Journal of Critical Reviews*, 7(6), 47-50.





# SCIENCE AND ART OF UZBEKISTAN AND INDIA STRENGTHENING CULTURAL TIES IN VARIOUS FIELDS AS A FORM OF PUBLIC DIPLOMACY

**Sardor Ikhtiyor oglu Doniyev**

*History, Tashkent region Chirchik State Pedagogical Institute, Chirchik, Uzbekistan*

## ABSTRACT

*This article provides information about the diplomatic relations between Uzbekistan and India in the twentieth century and after the independence of Uzbekistan, which have established political, cultural and trade ties since ancient times. The main points in this article relate to people's diplomacy, which is developing between the two countries and acts as a "soft power".*

**KEYWORDS:** *friendship, cultural ties, art, folk, science, education, art, scientific work.*

## 1. INTRODUCTION

The establishment of Soviet power in Uzbekistan created certain restrictions in all spheres, as well as in foreign policy. Interstate cooperation began to be established on the basis of an administrative command system, under ideological pressure, based on political interests. At the same time, the national traditions, customs, national culture and art of the peoples were introduced to the world in the ideological interests of the Soviet state. In this way, the Uzbek culture was given a socialist character and developed on the basis of a certain pattern. Any attempt to develop national culture and introduce it to the world was considered a form of nationalism. In particular, the great religious scholars of our people, such as Imam Bukhari, Ahmad Yassavi, Bahauddin Naqshbandi, Isa at-Termizi, Mahmud Zamakhshari, Burhaniddin Margilani, Amir Temur, Jaloliddin Manguberdi, Babur Mirzo, Ulugbek, etc., were included in the coverage of our history. National pride was shattered by accusations of nationalism and the superiority of one's own nation over other fraternal peoples. Nevertheless, a number of figures of science, literature, culture and art have worked effectively to preserve the national values of the Uzbek people and promote them to the world. Since the 1960s, with the permission of the Center for Independent Relations between Indian and Uzbek scientists, contacts have been established in all areas of scientific cooperation.

The Department of Indian Philology was opened at the Faculty of Oriental Studies of Tashkent State University, where students were taught Hindi, Urdu, Bengali and Punjabi dialects. The Institute of

Oriental Studies of the Academy of Sciences of Uzbekistan also collected sources on the history of India, and in 1957 the sector of history, economy and culture of the peoples of India and Pakistan was established [1]. Leading Indian scholars J. Nehru, Rajendra Prasad, Lal Bahadur Shastri and Indra Gandhi also paid official visits to Uzbekistan. They visited the Indian Literature Department and the Indian Manuscripts Fund at the institute[2].

## 2. DISCUSSION

During the 50s and 90s of the last century, the works of Indian writers and poets Robindranath Tagore, Prem Chand, Krishan Chandr, Sajjad Zahid, Amrita Pritam, Ali Sardor Jafri were translated into Uzbek. Also, a collection of poems by the poet Zulfiya "Mushoira", Pirimkul Kadyrov's novel "Starry Nights" in Hindi, Punjabi, Odil Yakubov's novel "Treasure of Ulugbek", Oybek's "Kutlug 'kan". Ghafur Ghulam's Shum Bola has been translated into Hindi and published in large numbers in India [3]. In 1983, the Indian dance and drama troupe "Shiriram Bhartiya kala Kendra" toured Tashkent, and its artistic director, Amok Bhagawa, was pleased with his visit and said: "We were received in Tashkent as our dearest guests. We have exhibited our art in dozens of countries, but nowhere have we seen a nation as well-understood and appreciative of art as it is here. When we visited the Tashkent School of Choreography, we saw that it teaches dancers at a high professional level. We now understand the solid foundation of Uzbek dance ensembles such as "Bahor" and "Lazgi". I didn't see them perform in India, I was amazed." [4].





After gaining independence, the Republic of Uzbekistan has undergone radical reforms in the cultural and spiritual spheres. Uzbekistan's integration into the world community takes into account the rich cultural heritage of the Uzbek people, national values, and the historical experience of international relations. A number of ministries, agencies, institutions, governmental and non-governmental organizations are responsible for establishing international cultural ties. At the same time, in order to establish and develop interstate cultural ties, a system of local [5] and international [6] institutions of our country has been established.

In developing cultural ties between the Republic of Uzbekistan and India, the Indian Council for Cultural Relations (ICCR), the Uzbek-Indian Friendship Society, the Uzbek-Indian Information Technology Center and others are also involved. It has a great impact on the development of relations between states. At the same time, it contributes to the development of cultural ties between Uzbekistan and India. In general, cultural ties with Uzbekistan and India have a long history and have a rich experience in resolving international economic and political issues, as well as in establishing cultural ties. The current state policy in the field of cultural life has led to the strengthening of Uzbekistan's position among other countries in the integration of international cultural relations. The rich cultural potential of the country, the universal potential of the Uzbek national culture, the compatibility of the Uzbek national culture with the universal values are recognized by the world community.

At present, the higher education institutions of the republic participate in international programs and cooperate directly with foreign educational institutions.

After India declared its independence in 1947, the Department of South Asian Languages was established at the present-day Tashkent State Institute of Oriental Studies (now a university). Since this year, the state language of India, Hindi, has been taught in Uzbekistan.

Since the recognition of Uzbekistan's independence by the world community in 1991, a new era in Uzbek-Indian scientific cooperation has begun. Along with Uzbek scholars, Indian specialists - J.Sarkor, Qamar Rayis, Tivari Farooqi, Hashemi, Suryakumari, Muhammad Amin - work at the Institute of Oriental Studies and help Uzbek students to master the Indian language. 'mak makers.

Madan Mohan Hardat, an Indian language teacher, has been working in Uzbekistan for many years. In turn, this scientist has made a great contribution to the development of scientific ties between our peoples. In a short period of time, Indian scholars also appeared in Uzbekistan. R.Qayumov, S. Chernikova, O. Shomatov, T. Holmirzayev, R. Gulomova, X. Begizova, Sh. Jalilov, A. Aulova, O.

Polinova, T. Khojayev conducted research on the Indian language and achieved a scientific degree [7].

At present, the department has a doctor of philological sciences, professor O. Shomatov, doctor of philological sciences, professor A. Ibragimov, and other Indian scholars. For almost 75 years, more than 800 specialists have been trained here. More than 50 graduates have defended their PhD and doctoral dissertations on current issues in Indian studies [8]. To date, the university professors have published more than 10 monographs, more than 300 textbooks, teaching aids and many scientific articles on important areas of the Hindi language [9]. These include R. Aulova's "Hindi", R. Muhammadjanov's "Urdu", O. Shomatov's "Chrestomathy of the South Indian language", "Dictionary of words of ancient Indian culture", "Normative grammar of the Indian language" and the department. It is worth noting that the "Indo-Uzbek dictionary" compiled by teachers and published in India.

There are several schools in Uzbekistan that specialize in Hindi, and scholars have been developing curricula and literature in Hindi and Urdu for these institutions. The textbook "Hindi language" for high school students in the field of Oriental Studies has been published. It is worth noting the work done at the Tashkent State University of Oriental Studies to further improve the quality of bachelor's and master's degrees, to provide the necessary textbooks. Professor O. Shomatov's three-part pamphlet and textbook "Introduction to South Asian Languages" and Associate Professor T. Khodjaev's "Literature of the Peoples of India" are also noteworthy. In the past, a number of scientific studies have been conducted on the theoretical study of the languages of the South Asian region. The subject of these works is closely connected with the problems of lexicology of Oriental languages, which are traditionally studied [10].

Scientists of the Tashkent State University of Oriental Studies have participated in many international scientific conferences and demonstrated the achievements of the Uzbek School of Hinduism around the world. O. Shomatov, T. Holmirzaev, A. Ibragimov, M. Abdurahimov, professors and teachers of the University, lectured on Indian studies at conferences and scientific seminars in India, USA, England, Pakistan, Turkey. It should be noted that the chase is coming. The role of the Lal Bahadur Shastri Cultural Center of India in Tashkent is especially important in the development of cultural ties between Uzbekistan and India. In this regard, teachers of the Tashkent University of Oriental Studies conduct courses in Hindi and Indian studies at the center.

At the same time, in cooperation with the Embassy of India and the Center, they are working hard to translate and publish Indian literature in Uzbek. As an example, one of the examples of ancient Indian didactic literature, "Hutona-dasha or



exemplary stories" was translated by A. Ibragimov. and is working closely with the institute's teacher center in publishing.

Tashkent State University of Oriental Studies and the Indian Cultural Center also hosted an international seminar on the teaching of Hindi, which was attended by a group of visiting scholars from India. As of 2011, the Embassy of India in Uzbekistan has donated more than 2,000 scientific and literary works and computers to the Tashkent State University of Oriental Studies [11]. The Mahatma Gandhi Center for Indian Studies was established in 2008 at the Tashkent State University of Oriental Studies [12]. The main purpose of the center is to conduct research on topical issues of Indian studies, to hold various international conferences, to further develop literary ties between the two peoples, as well as to pay special attention to the field of translation. The Uzbek-Indian Information Technology Center named after Jawaharlal Nehru was opened in Tashkent in April 2008 [13]. The first meeting of the Uzbek-Indian Joint Working Group on Information Technology was held in Delhi in January 2011.

Uzbekistan has a rich experience in cooperation in the field of education, health and human resources development. As part of India's Technical and Economic Assistance (ITES) program, many Uzbek specialists have been trained in prestigious higher education institutions in India in areas such as information technology, water management, banking and hotel business. In 2010, the Government of India provided a \$ 1 million grant to Uzbek health facilities to purchase medical equipment [14]. There is a growing worldwide focus on the use of information technology and its widespread use in life. One of the main reasons for the development of this sector is that in all spheres of society, education, science and technology, medicine, agriculture, engineering, aviation, space, and even in the system of political management can not be imagined without information technology.

The establishment of cooperation with leading countries of the world contributes to the achievement of significant results in improving the quality of services in the field of modern information and communication technologies and the training of qualified personnel in our country. This can be seen in the relationship with India, where the programming market is highly developed. It should be noted that the visit of the delegation of the Ministry of Communications and Information Technologies of the Republic of India led by the Minister of State Sachin Paylot to Tashkent is of great importance [15]. The delegation of the Ministry of Communications and Information Technologies of India visited the Center for Telecommunications and Personnel Development of Uzbektelecom JSC to get acquainted with the process of retraining and

advanced training in the field of information technology.

The guests got acquainted with two lecture halls here. The rooms are equipped with modern DWDM technology, DATACOM data transmission, CDMA and GSM mobile communication standards, optical transmission systems equipment. The center also has a security room equipped with all necessary equipment, video conferencing and a conference room for distance learning. The guests, who got acquainted with the activities of the center, praised the classrooms and laboratories. The members of the delegation paid special attention to the training of specialists in the field of software development in our country. They were given the example of the Center for Training and Support of Young Programmers. It was noted that the center offers a wide range of IT training courses, ranging from basic computer literacy to network administrators and engineers, database programmers and other similar certified professionals. Tashkent University of Information Technologies was the main program of the visit of the delegation led by Mr. Sachin Paylot. The reason is that the Uzbek-Indian Center for Information Technology named after Jawaharlal Nehru operates at the university. During the meeting, the distinguished guest was acquainted with the activities of the university. In particular, they spoke about the international relations of the university. In turn, the Minister expressed readiness to assist in expanding contacts and conducting joint research in this area through the exchange of students and professors.

The guests also got acquainted with the distance learning process between TUIT and its regional branches, as well as other universities of the country. It was expressed a desire to organize similar distance learning courses with Indian universities. The Uzbek-Indian Center for Information Technology at TUIT was established on the basis of a Memorandum signed between the Governments of the Republic of Uzbekistan and the Republic of India on October 29, 2004 in Delhi and has been operating since 2006. The opening ceremony was attended by the Prime Minister of the Republic of India Manmohan Singh. In particular, it said: "Modern technology has made it possible to remove the barriers of time and distance, to accelerate the stages of development of countries. I am confident that this center will provide Uzbek specialists with the knowledge and skills to compete confidently in the world market." The Uzbek-Indian Center has been able to carry out a wide range of work in a short period of time.

### 3. CONCLUSION

Based on the above data, it can be concluded that the relations between Uzbekistan and India in the field of education, science and culture are strengthening and developing year by year. In this



regard, the proposals of the heads of state to further strengthen cooperation between the two countries will play an important role during their visits. This has a significant impact on the development of science and education in our country.

#### 4. REFERENCES

1. A'zamova S. Obidov B. *Current Uzbekistan*. T. 1991.-56 pages
2. *That source*. T. 57 pages
3. A'zamova S. Obidov B. *Current Uzbekistan*. T. 58 pages.
4. *The same source* T. 59 pages.
5. *Resolution of the Cabinet of Ministers under the President of the Republic of Uzbekistan of January 13, 1992. - Resolution of the Republican International Cultural Center (Collection of Resolutions of the Cabinet of Ministers, pp. 1 43-44) on the establishment of the National Association of International Cultural and Educational Relations of the Republic of Uzbekistan of March 25, 1992 (Collection of Resolutions of the Cabinet of Ministers, 3 P. 157.) Resolution of the Cabinet of Ministers of the Republic of Uzbekistan dated November 8, 1995 on the establishment of the Information Agency under the Ministry of Foreign Affairs of the Republic of Uzbekistan (Cabinet of Ministers Resolution №10 p. 9) September 25, 1996 Resolution of the Cabinet of Ministers of the Republic of Uzbekistan on the establishment of the Cabinet of Ministers of the Republic of Uzbekistan (Collection of Resolutions of the Cabinet of Ministers №9 p. 91)*
6. *Resolution of the Cabinet of Ministers of the Republic of Uzbekistan "On the establishment of the National Commission of the Republic of Uzbekistan for UNESCO" of December 1994 (Resolution of the Cabinet of Ministers of the Republic of Uzbekistan. B. 12 p. 34.) Resolution of the Cabinet of Ministers of the Republic of Uzbekistan (Resolution of the Cabinet of Ministers of the Republic of Uzbekistan. № 5. P. 23).*
7. *Social science in Uzbekistan. 2005 № 1-2 pp. 60-65.*
8. *www.gazetabirja. Friendly cooperation.*
9. *www.newspaper exchange. Interstate economic cooperation.*
10. *Social science in Uzbekistan. 2005 №1-2 pp. 60-65.*
11. *www. Gaetabirja. Uz. Yesterday and today.*
12. *The same site. Interstate Economic Cooperation.*
13. *Period. May 14, 2011.*
14. *Period.2011. May 14.*
15. *Website.www. —Ziyo. Net. Ancient friendship.*
16. Ерметов, А. А. (2018). *Из истории формирования рабоче-крестьянской инспекции в Туркестане (1919-1923 гг.).* *Ин Частное и общественное в повседневной жизни населения России: история и современность (региональный аспект)* (pp. 27-31).
17. Ерметов, А. А. (2017). *Роль органов контроля в укреплении советской государственной системы управления после Октябрьского переворота в Туркестанской АССР (1917-1925).* *Ин Экстремальное в повседневной жизни населения России: региональный аспект (к 100-летию Русской революции 1917 г.).* (pp. 115-121).
18. ERMETOV, A. A. (2021). *Political repression in Uzbekistan and peculiarities of the work of law enforcement agencies (1936-1938).* *Journal of Contemporary Issues in Business and Government, 27(3), 1311-1316.*



# RESEARCH ON ATTITUDES TOWARDS WOMEN IN CENTRAL ASIA

**N. Djuraeva**

*Candidate of Historical Sciences, Associate Professor, Uzbek State University of World Languages  
Tashkent, Uzbekistan*

## ABSTRACT

*This article discusses how a woman can be seen as the creator of a truly harmonious future of the nation, an active person in all spheres of society. During the years of independence, raising the status of women in society, protecting their rights and interests, improving working and living conditions has become one of the priorities and goals of public policy, and the issue of treatment of women has risen to the level of public policy and strategy.*

**KEYWORDS:** *woman, harmonious, future, nation, active person, spheres of society, rights, interests, working conditions, living conditions, priorities, goals of public policy, treatment of women, strategy, unique role, development of society, true value.*

## 1. RELEVANCE OF THE TOPIC

Women have always played an active and unique role in the development of society. During the years of independence, the issue of treatment of women in Uzbekistan has been the focus of public policy. Over the years, women have found their true value. It is the restoration of national and spiritual values that has changed the attitude towards women. The woman began to be seen as the creator of a truly harmonious future of the nation, an active person in all spheres of society. While the level of morality of any society is determined by the attitude towards women, from this point of view, from the first years of independence, Uzbekistan, under the leadership of the state and the government, pursued a policy of care for women.

The issue of women is a set of social issues that addresses issues such as the status of women in the family and society, the protection of their legitimate interests, employment, protection of motherhood and childhood.

In the words of President Sh. Mirziyoyev: "From time immemorial, our people have always shown great respect for the Holy Mother, women. Respect for women is, first of all, an expression of respect for the family, for the future of society.

From this perspective, the wise saying, "The cultural level of any society on earth is determined by its attitude toward women," certainly has a deep meaning [1].

During the years of independence, raising the status of women in society, protecting their rights and

interests, improving working and living conditions has become one of the priorities and goals of public policy, and the issue of treatment of women has risen to the level of public policy and strategy. "In this regard, it is expedient to quote the following views of President Sh. Mirziyoyev: In the current era of globalization, the protection of the rights and freedoms and legitimate interests of women is even more important. In particular, increasing the socio-economic and political-legal activity of women is becoming a requirement of the times".

## 2. METHODS

The article is based on the principles of generally accepted historical methods - historical, comparative and logical analysis, consistency, objectivity. Central Asian scholars have analyzed the study of women's attitudes during the Soviet era and the years of independence.

## 3. RESEARCH RESULTS

At a new stage of development of Uzbekistan, comprehensive reforms are being carried out in the socio-economic, cultural and educational spheres of society, and in this process, women's participation in qualitative changes and the solution of fundamental problems is growing year by year.

The Action Strategy for the five priority areas of development of the Republic of Uzbekistan for 2017-2021 also includes "Increasing the socio-political activity of women, strengthening their role in government and society, women, Ensuring





employment of girls graduating from professional colleges, their wide involvement in entrepreneurial activities, further strengthening of family foundations”[2].

As noted by President Sh. Mirziyoyev: “Currently, 45% of workers and employees in various sectors and industries in our country are women. In particular, about 1,400 sisters work in leadership positions in the system of state and public organizations. 17 of them are senators, 16 are deputies of the Legislative Chamber of the Oliy Majlis, and 1,075 are members of local councils of people’s deputies”[3].

As a result of consistent reforms in the protection of motherhood and childhood, “..in the last five years, the maternal mortality rate has risen from 23.1 to 19 per 100,000 live births, the under-five mortality rate from 14.8 to 13.9, and the infant mortality rate from 11 to 10,7. According to these indicators, Uzbekistan has fully achieved the UN Millennium Development Goals. According to leading international institutions, Uzbekistan is one of the leading countries in the world in terms of creating favorable conditions for women and protecting motherhood among 125 countries. In the world ranking, our country is among the top 10 countries that care about the health of the younger generation. As a result of measures taken to improve the gene pool of the population, the average life expectancy of women will increase from 66 to 73.5 years. Maternal and infant mortality decreased by 3 times” [177].

Ensuring the well-being of families, maintaining the stability of the socio-spiritual environment in families and neighborhoods, further strengthening a healthy lifestyle, healthy and creating an effective mechanism for a systematic study of the socio-spiritual status of families in order to expand the social partnership of public organizations in the upbringing of a harmoniously developed generation, it is planned to implement it in practice and to constantly study the real living conditions of the population, to provide methodological assistance to local communities in this regard, to identify existing problems in families and to develop a program of measures to address them. The decree reads: “In order to communicate with the population, especially women, access to families, solve their problems, ensure the interests of women, youth and minors, mobile and responsible specialists organize mobile receptions in the mahallas. psychological and medical assistance is provided. Domestic problems and shortcomings of citizens will be solved on the spot” [5.223-238]. At the same time, the implementation of this work in all regions of the country has formed a system of real study of the social situation of families, including women, and the provision of prompt and on-site practical assistance. It has created more opportunities for women's

employment, further support and development of their entrepreneurial and home-based activities, and improvement of domestic labor and income from the land. While all the potential and opportunities of the Uzbek woman of yesterday were not fully used for the development of society, the scientific potential, culture, spirituality, entrepreneurship, entrepreneurship, success of today’s Uzbek woman, hard work means that all conditions are created for women, who make up half of the population of our country, to take their rightful place in society, to show their talents and potential, and to fully protect the rights and interests of women is a priority of our state. In particular, the Decree of the President of the Republic of Uzbekistan Sh. Mirziyoyev dated February 2, 2018 “On measures to radically improve the activities in the field of support of women and strengthening the institution of the family” testifies to the growing attention to this area.

Historians R. H. Aminova and D. A. Alimova have studied the issue of women in Uzbekistan in the first years of independence on the basis of the national idea from today’s point of view [6.133;16-20].

In particular, R.Kh. Aminova in her pamphlet “Actual problems of social development in Uzbekistan in the context of perestroika” noted that the level of higher general education of women does not correspond to their professional occupation, noting that their employment in low-skilled or unskilled labor is greater than that of men, writes: “The share of women engaged in manual labor in industry, construction and agriculture is higher than in the country. The share of manual labor in the industry of the republic was 35.3%, and among women - 42.5%. Women’s heavy physical labor is not over yet”[7.10-11]. The scientist points out two groups of these problems, namely, the lack of technical equipment in production, where women’s labor is usually high, and the second, the unsatisfactory level of preparation of women for the profession. The historian noted that the policy of “reconstruction” allowed to openly express the problems in the social, economic and domestic life of women who had accumulated during the years of stagnation, but nevertheless, he writes with regret that the old relationship that has persisted in the family for 70 years has prevented women from telling the truth, leading them to despair, especially the hardest way to express inner rebellion - self-immolation [8.12].

D.Alimova’s scientific monograph critically examines the problem of women on the basis of the analysis of comprehensive documentary sources and archival materials [9.133]. The role of women in the socio-political and cultural life of Central Asia has been highlighted from a historical point of view. Also on the issue of women scientists - although only the “Attack” movement is evaluated on a new basis, its





history and the issue of “women’s cooperation”, the impact of agricultural collectivization policy on the situation of women, the role of land and water reform in 1925-29 in the emancipation of women, the activities of public organizations in this area, issues related to the involvement of women in social production, the relationship between the formation of a new type of women and cultural development remain relevant to the study on the basis of the ideology of national independence [10.90]. For the first time, a number of scientific articles have shed light on traditional, social views on the status of women in the family and society, as well as their historical roots [11.77; 119].

In the second half of the 1990s and the 2000s, in the spirit of new historical thinking, a new approach and methodology focused on the study of women's status in almost all fields of history and social sciences, such as economics, philosophy and law [12.22;28;53;20;41;20;27;26;33;29]. These dissertations shed light on the colonial nature of the Soviet government's treatment of women in the period under study, on the basis of the national idea, in a scientific and objective manner. However, some aspects of the problem have been addressed in these studies.

Y. A. Abdullaeva's “Women of Karakalpakstan: Yesterday and Today. The end of the XIX century and the XX century” special monographs and articles, because they contain scientific conclusions and extensive information based on archival documents [13.224;40-45;42-45;90-92]. In her monograph, Ya.A. Abdullaeva was the first to point out that the policy of the Soviet government and the Communist Party among women was contradictory, positive and negative, and that a set of special methods, forms and mechanisms of work was created between them. based on examples. He created a classification of the work done by the Soviets and the Communist Party.

In 2004, G. Muhabbatova, a researcher and candidate of historical sciences in Dushanbe, conducted research on “The contribution of women to cultural change in the Republic of Tajikistan: 1924-1941”. The urgency of the topic is determined by the fact that women make up 52% of the population, the implementation of socio-economic and political reforms, the stabilization of peace in sovereign Tajikistan in many respects depends on the growth of their role. Scientific conclusions on the role of women in the organization and development of public education in the early 1920s, their participation in the elimination of illiteracy among the adult population, women's activities in school education, their involvement in cultural and educational activities and professional activities are presented [14.144].

Another researcher, Doctor of Historical Sciences M. Zikrieva, conducted research on

“Historiography of women's issues in Tajikistan”. The dissertation analyzes that the solution of problems related to strengthening the independence of Tajikistan is related to the practical implementation of raising the social status of women, who make up 52% of the population [15.350].

Accordingly, the first period of the formation of Soviet power was marked by significant changes in the education system, in the protection of motherhood and childhood, in connection with the establishment of children's institutions.

Measures based on the Soviet model, aimed at “liberating” women, had a serious impact on the social status of women. Улар таълим олиш, меҳнат қилиш, мулкка эғалик қилиш ҳуқуқига эга бўлишди. The foundations for the protection of the rights of mothers and children have also been laid. However, such measures were taken in the interests of the Soviets, in connection with the denial of national identity, family values, the guarantees of equal rights were combined with discrimination against women in society. After the break-up of the former Soviet Union, neoconservative tendencies intensified in response to the “compulsory” and “coercive” nature of the Soviet state's “policy of liberating Eastern women,” the author notes [16].

The Soviets looked at women as symbolic political capital and tried to use them as benefactors of their own policy, an economic resource, educating the younger generation on the basis of the interests of communist ideology. They also noted that Central Asian women were a symbol of the “achievements” in the mission to “liberate” Eastern women in the outside world.

Indeed, the 1920s and 1930s marked a turning point in the fate of women in Central Asia. As a result of the policy aimed at changing the religion, history, culture, customs and traditions of the peoples of Central Asia, the lifestyle, social activity, role in society, social behavior of women has changed radically. While the communists in Central Asia were faced with the task of changing the minds and lifestyles of the people, they aimed primarily at harming Islam and taking women to the streets. Along the way, they first declared religion to be a harmful belief for the people. To them, the belief of people living in a communist society was to be “communist atheism”. On the other hand, various efforts have been launched to eradicate the veil of Central Asian women's street clothing.

The name of the movement against the wearing of women's shawls was called “Attack”. The removal of the shawl, on the one hand, led to the integration of women into society, their activism and social capacity, their place in society, and, on the other hand, allowed them to be heavily exploited as cheap labor. As a result of the veil, the country has a workforce of millions of women. Following the “attack” movement, the number of educated women



in Central Asia increased. But it was possible to make women educated without condemning religion and without carrying out the “Attack” movement in such a brutal manner.

The “Attack” campaign has undoubtedly been important in the history of Central Asia. And, among the many reforms and policies of the Bolsheviks, it is much more difficult to make a one-sided assessment of it. On the one hand, indeed, the role of women in society, the improvement of lifestyles has contributed to development. On the other hand, this has caused a lot of controversy in the society. The breakdown of families has led to the killing of women, also causing social problems.

#### 4.CONCLUSION

In modern society, the process of women’s self-identification is changing and their social status, culture and level of education are increasing. While this process has attracted the attention of many researchers, it is clear that dealing with women’s issues is not accidental. In particular, the recognition of the issue of women as a global social phenomenon and the consistent efforts to address the issue of women, their broad participation in social life enhances the status of women in society, giving them a wide range of activities. As a result, they were able to fully display their talents and abilities while enjoying economic independence. This process has led almost all countries to change their policies and attitudes towards women. Recognition that the future of the nation and society is full of women's participation, the world fully understands that society can have a perfect direction in its development only if their active participation in science, technology, production and management in all spheres of social life is achieved. Therefore, in today’s era of globalization and the clash of civilizations, the issues of further development of the place and role of women in modern society, which are considered important to address, as well as future development without the participation of women, are being put forward. It is now believed by many experts in the study of human development that the historical path and development traversed by humanity cannot be fully understood without studying the role of women in all spheres of human society. In particular, note the following opinion of Gisella Bock, a well-known researcher on the history of women: “In the past, women’s experiences, activities, and spheres of life have been neglected because they do not seem to have historical value. However, the history of women should be considered as general as the history of men [17.367], ... because it belongs not only to half of humanity, but to all” [18.371]. According to Joan Kelly, another well-known researcher on women’s history, “it’s not about returning women to history, it’s about returning history to women in the first place. While this focus is not only on women in

history, but also on women's history, it is also a special kind of history, a history of women all over the world as women”.

#### REFERENCES

1. *Speech by President of the Republic of Uzbekistan Shavkat Mirziyoyev at the Twentieth Plenary Session of the Senate of the Oliy Majlis // 22.06.2019.*
2. *“Women in Business and Management”. Report of the International Labor Organization. 2017. <http://www.mk.ru/social/2017/01/13/doklad-mezhdunarodnoy-organizacii-truda-dolya-zhenshinrukovoditeley-vmire-vsego-5.html>.*
3. *Congratulatory message of the President of the Republic of Uzbekistan Sh. Mirziyoyev on the occasion of March 8 - International Women’s Day // March 7, 2018*
4. *Scientific-methodical booklet on the study of the State Program for the implementation of the Action Strategy on the five priority areas of development of the Republic of Uzbekistan in 2017-2021 in the “Year of dialogue with the people and the interests of man”. Tashkent., Spirituality, 2017, P. 177.*
5. *Decree of the President of the Republic of Uzbekistan dated February 7, 2017 №4947 “On the Strategy of further development of the Republic of Uzbekistan”, paragraphs 223,238.*
6. *Alimova D.A. Women’s question in Central Asia: History of study and modern problems.-Tashkent: Science, 1991. –P. 133; Alimova D.A. “Was there a need for an attack?” // Literature and Art of Uzbekistan - September 11, 1992; Alimova D.A. The study and problems of women in the social sciences of Uzbekistan // The role of women and gender issues in the construction of the family, state and society in Uzbekistan.-Tashkent: Science. 1999. P.16-20.*
7. *Aminova R.X. Current issues of social development in Uzbekistan in the context of reconstruction. - Tashkent: Science.1991.P.10-11.*
8. *Aminova R.X. Current issues of social development in Uzbekistan in the context of reconstruction. - Tashkent: Science. 1991.P.12.*
9. *Alimova D.A. The Women’s Question in Central Asia: History of Studies and Contemporary Problems.-Tashkent: Science. 1991. –P. 133;*
10. *Alimova D.A. Women’s issue in Central Asia. - Tashkent: Science.1991.P. 90.*
11. *Alimova D.A. We should not be a society saturated with the idea of male superiority // Tashkentskaya Pravda. 1997, 26 March; The role of women and gender issues in the construction of the family, state and society in Uzbekistan.-Tashkent: Science, 1999.- P. 77; Women of Uzbekistan: yesterday and today.-Tashkent: 2005.-P. 119.*
12. *Ergashkhodzhaeva G.E. French historiography on the problems of emancipation of women in Central Asia in the 20s (Literature 50-80s). Diss. Ph.D. - Tashkent: 1996. -22; Q.V.Nishonboeva. Cultural aspects of addressing women’s issues in Uzbekistan.T.f.ndiss. Autoref. -Tashkent: 1998. –P. 28; Xolmatova M. Problems of improving the culture of family relations and raising a healthy generation. Doctor of Philosophy diss. avtoref. –Tashkent: 1998. – P. 53; Nasrullaeva X. Philosophical analysis of the*



- process of socialization of women in Uzbekistan. F.f.n. diss. Abstracts. –Tashkent: 2000. –P.20; 32 Matkarimova G.A. Gender and reproductive rights of women in international and national law. Abstract of the thesis. diss. Doctor of Juridical Sciences-Tashkent: 2002.-P. 41.; Safoeva S.X. The issue of women: general social and national aspects. Candidate of Philosophical Sciences diss. avtoref. –Tashkent: 2002. –P. 20; Rajabova D.N. Problems of youth and women in the views of the Jadids of Turkestan (late 19th - early 20th centuries) Abstracts of the thesis. Tashkent: 2003. –P. 27; Muravyova N.M. Socio-philosophical analysis of increasing the social status of women. Abstract of the thesis. Ph.D. –Tashkent: 2003.-P. 26; Jo'raeva N.D. The role of women in the socio-economic and cultural life of Uzbekistan (20-30 years of the XX century). Medical sciences. candidate. Autoref. -Tashkent: 2004. –P. 33; Khodjaeva S.A. Legal culture and problems of development of social and legal activity of women in the Republic of Uzbekistan. Auth. diss. Candidate of Law.—Tashkent:, 2004; Egamberdieva T.A. Socio-pedagogical bases of increasing women's activity in the spiritual life of the Republic of Uzbekistan. Doctor of Pedagogical Sciences. avt. —Tashkent: 2005; Abdullaeva Ya. A. Women's issue in Karakalpakstan at the end of the XIX-XX. Auth. —Tashkent, 2005; Ganieva G.Zh. Women's issue in Uzbekistan: new approaches, problems and solutions. Auth.—Tashkent:, 2006; Karimova M.A. The role of Islamic values in the social protection of women in Uzbekistan. Candidate of Philosophical Sciences. Autoref. -Tashkent: 2008. –P. 26; Nasretdinova D.M. "The role of Tatar-Bashkir women in the cultural life of Turkestan (late 19th century - first quarter of the 20th century). Candidate of Historical Sciences. Autoref. -Tashkent: 2011. –P. 29;
13. Abdullaeva Ya.A. Women of Karakalpakstan: Yesterday and Today. The end of the XIX century and the XX century. –Tashkent: The world of creativity. 2004. –P. 224; The same author. The policy of forced kolkhozization of the Soviet government in Karakalpakstan and the repression of rural women // History of Uzbekistan. 2002. №2. P. 40-45; Abdullaeva Ya.A. Some causes of the crisis of the dictatorial Soviet regime and its impact on the situation of women (on the example of Karakalpakstan) // Democratization and human rights. 2004. №1. P. 42-45; Abdullaeva Ya.A. Repressed oppressed law or tyrannical regime // Life and law. 2004. №2. P. 58-59; Abdullaeva Ya.A. Attack on faith // Contemplation.2004. №2. P. 90-92.
  14. Mukhabbatova G. The contribution of women to cultural transformations in the Republic of Tajikistan: 1924-1941. : Dissertation. Doctor of Historical Sciences: 07.00.09. -Dushanbe, 2004. P. 144.
  15. Zikrieva Malika Fayzievna. Historiography of the problem of women of Tajikistan: dissertation. Doctor of Historical Sciences: 07.00.09. - Dushanbe, 2002.- P. 350.
  16. Tatiana Shchurko "Attack": female emancipation during the early Soviet "experiments" in Soviet Kyrgyzstan (1918-1930)25.04.2015 .<http://www.art-initiatives.org/ru/tags/tatyana-shchurko>
  17. G. Bock. History, history of women, history of sexes // Chrestomathy of the Basics of Gender Research Course. –Tashkent: Uzbekistan, 2003. –P. 367
  18. Chrestomathy of the Basics of Gender Research Course. –Tashkent: Uzbekistan, 2003. –P.371



## TYPES OF WORLD PICTURES IN THE CONTEXT OF MODERN LINGUISTICS

**Zarina Bakhtiyarovna Khojjeva**

*PhD, Associate Professor of the Department of Linguistics and English Literature,  
Uzbekistan State University of World Languages*

### ABSTRACT

*The article is devoted to the study of the relationship between the conceptual picture of the world and the linguistic picture of the world. The author's focus is on the definition of the "linguistic picture of the world" and its varieties. In this regard, the work presents the following classification of the linguistic picture of the world: linguistic naive picture of the world, linguistic scientific picture of the world, linguistic national picture of the world.*

**KEY WORDS:** *linguoculturology, conceptual picture of the world, linguistic picture of the world, linguistic naive picture of the world, linguistic scientific picture of the world, linguistic national picture of the world.*

## ТИПЫ КАРТИН МИРА В КОНТЕКСТЕ СОВРЕМЕННОЙ ЛИНГВИСТИКИ

**Зарина Бахтияровна Хожиева**

*PhD, доцент кафедры «Лингвистика и английская литература»  
Узбекский государственный университет мировых языков*

### АННОТАЦИЯ

Статья посвящена изучению взаимосвязи концептуальной картины мира и языковой картины мира. В центре внимания автора находится определение понятия «языковая картина мира» и ее разновидностей. В этом плане в работе представлена следующая классификация языковой картины мира: языковая наивная картина мира (ЯНаивКМ), языковая научная картина мира (ЯНаучКМ), языковая национальная картина мира (ЯНацКМ).

**Ключевые слова:** лингвокультурология, языковая картина мира, концептуальная картина мира, языковая наивная картина мира, языковая научная картина мира, языковая национальная картина мира.

### ВВЕДЕНИЕ

На сегодняшний день в современных лингвокультурологических исследованиях наблюдается активное использование понятия «языковая картина мира» (С.Г. Воркачев, Е.В. Урысон, М.В. Пименова, В.А. Маслова, О.А. Корнилов) [5,15,10,11,9,8]. Однако, несмотря на

многочисленные исследования, посвященные понятию языковой картины мира (далее – ЯКМ), многие проблемы остаются недостаточно изученными. Учитывая сложность и разносторонность понятия ЯКМ, считаем важным рассмотреть различные дефиниции ЯКМ как в рамках лингвистической науки, так и частично в





некоторых других смежных науках (философия, культурология, психология и т.д.). Перед тем как приступить к рассмотрению разных трактовок ЯКМ, целесообразно обратиться к понятию «картина мира» (КМ).

### ОБСУЖДЕНИЕ И РЕЗУЛЬТАТЫ

Применительно к лингвистике КМ определяется как «результат переработки информации о среде и человеке» [Цивьян Т. с.5]; как «исходный глобальный образ мира, лежащий в основе мироведения человека, репрезентирующий сущностные свойства мира в понимании ее носителей и являющийся результатом всей духовной активности человека» [Постовалова В.И.,1988: с.21]. В.И. Карасик определяет ее как «целостную совокупность образов действительности в коллективном сознании» [Карасик, В.И.,2009: с.88]. Следует отметить, что система знаний человека об окружающей его действительности отражается в языке. «Пропустив их через свое сознание, осмыслив результаты этого восприятия, он передает их другим членам своего речевого коллектива с помощью языка» [Тер-Минасова С.Г., 2008: с.40].

Таким образом, картина мира – это отображение окружающего мира в сознании человека, которая выражается определенными языками.

В современной лингвистике отмечается метафорическая природа понятия ЯКМ. В связи с тем, что у исследователей различные научные интересы и цели, понятие ЯКМ приобрело множество интерпретаций. Так, например, ЯКМ, по определению Ю.Д. Апресяна – «зафиксированная в языке и специфичная для данного языкового коллектива схема восприятия действительности» Апресян Ю.Д.,1995: с.39]. М.В. Пименова понимает ЯКМ как «совокупность знаний о мире, которые отражены в языке, а также способы получения и интерпретации новых знаний» [Пименова М.В., 1999: с.9]. О.А. Корнилов – «как фиксация и хранение всего комплекса знаний данного языкового сообщества о мире» [Корнилов О.А., 2013: с.4]. Наиболее адекватным пониманием ЯКМ представляется определение ее как «совокупность зафиксированных в единицах языка представлений народа о действительности на определенном этапе развития народа, представление о действительности, отраженное в значениях языковых знаков, – языковое членение мира, языковое упорядочение предметов и явлений, заложенная в системных значениях слов информация о мире» [Попова З.Д., 2007: с.38]. Однако следует отметить, что ни одна из вышеперечисленных трактовок не может

претендовать на роль общепринятой дефиниции, что и подтверждает метафоричность ЯКМ.

Соотношение понятий ЯКМ и концептуальной картины мира (ККМ) является одной из актуальных проблем, посвященных исследованию ЯКМ. Первоначальное разграничение этих понятий было предложено Г.А. Брутяном. Согласно концепции ученого, дифференциальное изучение концептуальной и языковой картин мира способствует решению проблемы взаимосвязи языка и мышления, значимости языка в формировании и осознании реальной действительности [Брутян Г.А., 1973: с.108]. Противопоставление ученым этих понятий способствовало возникновению проблемы взаимоотношения концептуальной картины мира и языковой картины мира.

В отношении этой проблемы ученые выдвигают две точки зрения, соответственно существуют два подхода. Так, представители первого, развивая мысль Г.А. Брутяна о том, что «основное содержание языковой модели мира покрывает все содержание концептуальной модели мира» [Брутян Г.А., 1973: с. 108], считают, что языковая картина мира полностью отражает концептуальную картину мира. По этому поводу Г.А. Брутян говорит о важной роли языка в познании, которое заключается не только в том, что в языке закрепляется и сохраняется результат отражения окружающего мира, но, кроме того, этот результат подвергается определенному воздействию со стороны языка, поэтому автор делает вывод, что для знания характерен языковой характер. Исходя из этого Г.А. Брутян считает правомерным выделение в картине мира концептуальной (мыслительной) модели мира (КММ) и языковой картины мира (ЯКМ). КММ определяется автором как «не только знание, которое выступает как результат мыслительного отражения действительности, но и итог чувственного познания, в снятом виде содержащийся в логическом отображении», ЯКМ – как «вся информация о внешнем и внутреннем мире, закрепленная средствами живых, разговорных языков» [Брутян Г.А., 1973: с.108].

Представители второго подхода, выдвигая мысль о зависимости языковой картины мира от концептуальной картины мира, полагают, что языковая картина мира отражает не все содержание концептуальной картины мира. Основные аргументы сторонников данного подхода изложены в труде Г.В. Колшанского «Объективная картина мира в познании и языке», который полагает, что «языковая картина мира есть вторичное существование объективной картины мира» [Колшанский Г.В.,1990: с.40]. Сторонники этого подхода категорически убеждены, что в языке «присутствует далеко не





все содержание концептосферы, далеко не все концепты имеют языковое выражение и становятся предметом коммуникации» [Попова З.Д., 2007: с.39].

Придерживаясь сторонников второго подхода, мы считаем, что концептуальная картина мира более широкая чем языковая поскольку «языковой мир рассматривается как репрезентант концептуального мира, который в свою очередь репрезентирует реальный объективный мир, а репрезентирующая система всегда беднее репрезентируемой, как метаязык беднее естественного языка» [Пименова М.В., 2011. с.37].

В лингвистической литературе наблюдается большой разбой мнений относительно классификации внутри как концептуальной картины мира, так и языковой картины мира. Очевидно, что лингвистические исследования проводятся в основном в русле языковой картины мира, поэтому мы сосредоточим свое внимание на различных типах языковой картины мира. Изучение лингвистической литературы по данному вопросу, а также наши собственные наблюдения позволили представить типологию языковой картины мира, подразделяющейся на: наивную картину мира (НаивКМ), научную картину мира (НаучКМ), национальную картину мира (НацКМ), художественную картину мира (ХКМ), индивидуально-авторскую картину мира ИКМ. Следует отметить, что концептуальная картина мира также подразделяется на вышеупомянутые типы, однако различие между ними заключается в том, что все типы концептуальной картины мира содержатся в сознании индивидуума/коллектива, а типы языковой картины мира представлены в языке.

В настоящий момент в исследованиях, посвященных ЯКМ, особо подчеркивается наивный характер ЯКМ (см. работы Ю.Д. Апресяна, С.Г. Воркачева, Е.В. Урысон, М.В. Пименовой, О.А. Корнилова). В исследовании наивной природы ЯКМ основополагающей является концепция, предложенная Ю.Д. Апресяном, согласно которой «языковая картина мира как бы дополняет объективные знания о реальности, часто искажая их (см. научные знания и языковое толкование таких слов, как атом, точка, свет, тепло и т. д.). Изучая семантику этих слов, можно выявить специфику когнитивных (мыслительных) моделей, определяющих своеобразие наивной картины мира» [Апресян Ю.Д., 1996: с.257]. Наивный (донаучный) характер ЯКМ интерпретируется автором тем, что, в отличие от научной картины мира, она отражает бытовые (обиходные) представления о мире. Данная концепция также получает свое

развитие в исследованиях М.В. Пименовой, где ученый отмечает, что «в наивную картину мира входят наивная психология, наивная антропология, наивная физика, наивная геометрия и т.д. Именно в наивных представлениях ученые видят зачатки научной классификации» [Пименова М.В., 1999: с.10]. В связи с этими высказываниями, следует разграничивать «научную картину мира» на: (НКМ) и НаивКМ.

В научной лингвистической литературе НКМ трактуют как «систему наиболее общих представлений о мире, вырабатываемых в науке и выражаемых с помощью фундаментальных понятий и принципов этой науки, из которых дедуктивно выводятся основные положения данной науки» [цит. по: Постовалова В.И. с.14]. «Наивная картина мира» в рассуждениях С.Г. Воркачева как «факт обыденного сознания воспроизводится по фрагментно в лексических единицах языка, однако сам язык непосредственно этот мир не отражает, он отражает лишь способ представления (концептуализации) этого мира национальной языковой личностью» [Воркачев С.Г., 2001: с.67].

Освещение этого вопроса подробным образом дано в монографии О.А. Корнилова, который понимает НКМ в суженом и широком смысле. В суженом смысле под НКМ автор подразумевает «всю совокупность научных знаний о мире, выработанную всеми частными науками на данном этапе развития человеческого общества» [Корнилов О.А., 2013: с. 9]. НКМ в широком смысле – «это отражение коллективного знания о мире, который включает и природу, и общество, и человека как общественное существо» [Корнилов О.А., 2013: с. 10]. Широкое понимание НКМ О.А. Корнилова аналогично понятию «общая научная картина мира» (ОНКМ), в основе которой лежат представления «единства эволюции Вселенной и человека как существа биологического и социального» [там же].

В работе О.А. Корнилова проводится сопоставление и противопоставление НКМ и ЯКМ. Различие НКМ от ЯКМ исследователь видит в ее объективности, непрерывности, динамичности. ЯКМ в свою очередь субъективна. В ней фиксируется глобальное представление о мире определенного общества на этапе первичного, донаучного познания мира. Если НКМ, используясь учеными, всегда развивается, совершенствуется, изменяется, то ЯКМ стабильна, в чем и заключается «ее суть и предназначение – сохранять и из поколения в поколение воспроизводить упрощенное, обиходное структурирование окружающего мира, обеспечивать преемственность языкового мышления носителей данного языка традиционно



сложившимися категориями» [Корнилов О.А., 2013: с. 14-19]. Однако, на наш взгляд, данная концепция является неправомерной. Поскольку НКМ, как и КМ в целом может быть концептуальной научной картиной мира и языковой научной картиной мира. В связи с этим сопоставление ЯКМ и НКМ представляется нелогичным.

Национальная картина мира воплощается в языковой картине мира всех национальных языков и получает обозначение «языковая национальная картина мира» (ЯНацКМ). Понятие ЯНацКМ понимается О.А. Корниловым как «запечатленное в лексике соответствующего языка национально-специфическое видение всего сущего» [Корнилов О.А., 2013: с.140]. В современной лингвистике отмечается тесная связь понятия ЯНацКМ с понятием «менталитет». Понятие менталитет в интерпретации Н.Ф. Алефиренко, – это «своего рода стереотипная установка культурно-когнитивного «камертона» на восприятие наивной картины мира сквозь призму ценностной прагматики этнокультурного сознания» [Алефиренко Н.Ф., 2010: с.109]. Изучая проблему взаимосвязи языка и культуры с ментальностью народа, ученый приходит к выводу, что «именно вербализованный опыт, знания, культура, накопленные определенным этноязыковым сообществом, и создают ментальность – своеобразную форму овладения миром» [Алефиренко Н.Ф., 2010: с.110,111]. Понятие ЯНацКМ также взаимосвязано с понятием национальный характер. Согласно С.Г. Тер-Минасовой основой национального характера, которое свидетельствуют о его существовании является язык, поскольку именно он «и отражает, и формирует характер своего носителя» [Тер-Минасова С.Г., 2008: с.147].

## ЗАКЛЮЧЕНИЕ

Одним из важнейших понятий современной лингвистики является понятие ЯКМ, которая представляет собой языковую фиксацию концептуальной картины мира как отображение в сознании человека всего комплекса знаний об окружающем мире. ЯКМ подразделяется на такие типы как: ЯНаивКМ, ЯНаучКМ, ЯНацКМ, ЯХКМ, ЯИКМ В перечислении всех типов картин мира особый статус получает ЯНацКМ, которая пронизывает все вышеуказанные типы картины мира.

Понятие ЯНацКМ тесно переплетается с проблемой соотношения языка и культуры. Язык является неотъемлемой частью национальной культуры, национального менталитета и национального характера. В связи с этим исследование ЯНацКМ предполагает анализ

языковых единиц и текстов, являющихся носителями национальной культуры. В этом плане художественный текст, рассматриваемый как средство концептуализации национальной картины мира имеет первостепенную значимость. В лингвистической науке также отмечается тесная связь понятия ЯНацКМ с понятием «менталитет».

## Список использованной литературы

1. Алефиренко Н.Ф. Лингвокультурология: ценностно-смысловое пространство языка. – М.: Флинта: Наука, 2010. – 288 с.
2. Апресян Ю.Д. Образ человека по данным языка: попытка системного анализа // Вопросы языкознания. 1995. № 1. С. 37-67
3. Апресян Ю.Д. Избранные труды. Т. 2. Интегральное описание языка и системная лексикография. – М.: Языки русской культуры, 1996. – 767 с.
4. Брутян Г.А. Язык и картина мира // Научные доклады высшей школы. Философские науки. М., 1973. № 1. – С. 84-112
5. Воркачев С.Г. Лингвокультурология, языковая личность, концепт: становление антропоцентрической парадигмы в языкознании. Филологические науки. – 2001 – № 1. – С. 64-72
6. Карасик, В.И. Языковые ключи. — Москва: Гнозис, 2009. – 406 с.
7. Колишанский Г.В. Объективная картина мира в познании и языке. М.: 1990. – С.23.
8. Корнилов О.А. Языковые картины мира как производные национальных менталитетов. – М.: КДУ, 2013. – 348 с.
9. Маслова В.А. Лингвокультурология. – М.: Академия, 2001 – 208 с.
10. Пименова М.В. Этногерменевтика языковой наивной картины внутреннего мира человека. – Кемерово: Кузбассвузиздат, 1999. – 262 с.
11. Пименова М.В. Кондратьева О.Н. Концептуальные исследования. Введение: учебное пособие. – М.: Флинта, 2011. – 176 с.
12. Попова З.Д., Стернин И.А. Семантико-когнитивный анализ языка. Монография. Воронеж: изд-во Истоки, 2007. – 250 с.
13. Постовалова В.И. Картина мира в жизнедеятельности человека// Роль человеческого фактора в языке: языки картина мира. – М.: Наука 1988. – С. 8-69
14. Тер-Минасова С.Г. Язык и межкультурная коммуникация. – М.: Слово, 2008. – 264 с.
15. Урысон Е.В. Проблемы исследования языковой картины мира. Аналогия в семантике. М.: Языки славянской культуры, 2003. – 224 с.
16. Цивьян Т.В. Лингвистические основы балканской модели мира – М.: Наука, 1990. – 207 с.



## USE OF INULINE AS A SUPPORTING SUBSTANCE IN THE TABLET TECHNOLOGY

<sup>1</sup>K. S. Ibragimova, <sup>2</sup>A. Sh. Khusenov, <sup>3</sup>G. R. Raxmonberdiev, <sup>4</sup>M. M. Shokirova

### ABSTRACT

*Scientific studies on the use of inulin as a binder for solid medicine forms are presented. For active substances with different physical-chemical properties, inulin solution has been studied as a binder in relation to traditional starch slime, and its use as a binder in the manufacture of medicines has been found expedient.*

**KEYWORDS:** *inulin, binder, technology, tablet, appearance, hardness, breakage, disintegration.*

### DISCUSSION

It is known that today the development of the pharmaceutical industry, the launch of production of products that meet the requirements of world standards of quality of the finished product is one of the urgent tasks.

According to the literatur, a substance that treats diabetes - inulin and biologically active additives based on it is obtained from the topinambour tubers (*Helianthus tuberosus* L.). We first proposed inulin as a binder for solid drug forms. The aim of proposing inulin as a binder is that inulin itself is widely used to reduce the amount of sugar in the body in patients with diabetes. If it is used as a binder when taking a pill, it can not only acts as a filler but also acts as a lowering sugar in addition to the drug's effect on the pill itself. Therefore, we aimed to conduct scientific research on the application of a new local excipient as an inulin binder in the tablet technology [1-4].

Inulin is a white, odorless, water-soluble, powdered substance. To use of inulin as a binder the active substances with the following different physicochemical properties: phytin, ampicillin, rutin

and ascorutin (a mixture consisting of ascorbic acid and rutin) were obtained. Each mass was compressed using 5% starch slurry and 1.3 and 5% inulin solutions, which are widely used on an industrial scale. The masses were made in the traditional way by wet granulation. 1% antifriction agent (calcium stearate) was added to the prepared masses for grinding. Then sample tablets were prepared from the prepared masses. The sample tablets were pressed using a mold with a diameter of 11 mm, a mass of 0.5 g tablets with a pressure of 120 MPa using a hydro-press. In the first step of the study, the following quality indicators were studied: appearance, uniformity of the tablet surface, refractive hardness and disintegration of the tablets according to the methods described in the scientific literature. The interaction of active and excipients was also emphasized during the experiments. The prepared tablets were stored in glass jars with screw caps BS 64 - 2 - 71 - 80, approved for medical use, and stored at room temperature.

The results obtained on the quality of tablets based on starch slurry are given in Table 1.

**Table 1**

**The results of the study of the effect on the quality of tablets based on 7% starch slurry**

The indicator under study, a unit of measurement	Name of the active substance			
	Phytin	Rutin	Ampicillin	Ascorutin
Appearance	Specific color, whole edges, glossy tablet			
Hardness: - refractive index, H	85,0	78,0	80,0	74,0
Disintegration, C	480,0	300,0	660,0	540,0



It can be seen from the table that when the appearance of the tablets based on 7% starch slurry was organoleptically examined, it was found that the tablets studied had a specific color, glossy appearance and whole edges, refractive hardness and

disintegration and these features might meet the relevant ND requirements. In our subsequent studies, the quality indicators of tablets based on 1.3 and 5% inulin were determined. The results of the experiment are given in Table 2.

**Table 2**  
**Results of the study of the effect on the quality of tablets prepared on the basis of inulin solution in different percentage**

The indicator under study, a unit of measurement	Name of the active substance			
	Phytin	Rutin	Ampicillin	Ascorutin
1% - inulin solution				
Appearance	Specific color, whole edges, glossy tablet			
Hardness: - refractive index, H	85,0	76,0	78,0	60,0
Disintegration, C	660,0	480,0	660,0	420,0
3% - inulin solution				
Appearance	Specific color, whole edges, glossy tablet			
Hardness: - refractive index, H	95,0	88,0	87,0	80,0
Disintegration, C	720,0	600,0	780,0	600,0
5% - inulin solution				
Appearance	Specific color, whole edges, glossy tablet			
Hardness: - refractive index, H	100,0	94,0	90,0	86,0
Disintegration, C	> 900,0	> 960,0	>900,0	780,0

We can see in table 2 that the appearance of tablets based on 1 and 3% inulin solution has a specific color, glossy appearance and whole edges, refractive hardness and disintegration meet the relevant ND requirements. Although the appearance of the tablets prepared with 5% - inulin solution was at the required level, the disintegration of the complex ascorbutin tablet was found to be satisfactory due to the high refractive index of the tablets, and the disintegration of the remaining tablets did not meet the relevant ND requirements. Its 5% solution can be used as a binder for solid medicine forms with prolonged effect.

It was found expedient to use 1 and 3% solutions of inulin when comparing the proposed inulin

solution as a binder for solid medicine forms with 7% starch slurry.

## REFERENCES

1. Государственная фармакопея Российской Федерации. –12-е изд.–Часть 2. – М.: Науч. центр экспертизы средств мед. применения, 2010.
2. Балаболкин М.И. Сахарный диабет. М. 2008. - 383 с.
3. Кочнев Н.К., Решетник Л.А. Лечебно-диетические свойства топинамбура (земляной груши) / -Иркутск: ТОО «Биотек», 1997. – 12 с.
4. Шендеров Б.А. Пробиотики и функциональное питание. - М, 2001. -95 с.

<b>Ibragimova Komila Sadriddin kizi</b>	PhD student - Tashkent chemical-technological institute, department "Technology of cellulose and woodworking"
<b>Khusenov Arslonnazar Shernazarovich</b>	Doctor of chemistry sciences, - Tashkent chemical-technological institute, department "Technology of cellulose and woodworking"
<b>Rakhmonberdiev Gappar Rakhmonberdievich</b>	Doctor of chemistry sciences, - Tashkent chemical-technological institute, professor of the department "Technology of cellulose and woodworking"
<b>Shokirova Mukaddaskhon Musakhonovna</b>	Independent researcher - Tashkent chemical-technological institute, department "Technology of cellulose and woodworking" Tashkent chemical-technological institute, senior teacher of the department "The Uzbek language and literature"





# PUBLIC ADMINISTRATION SYSTEM IN UZBEKISTAN

**Kamoliddin Mirzaakhmedov\***

*\*Doctor of philosophy (PhD) Political Sciences. National University of Uzbekistan named after MirzoUlughbek, Tashkent, Uzbekistan*

---

## ABSTRACT

*In this article investigated the formation of basic principles of public administration system, development of the state system, including the socio-cultural aspects of the teachings of Eastern and Western thinkers, the boundaries between democracy and state power, and the development of public administration, in its essence, the transition from administrative methods to quality management. Also researched the object of management related to the activities of public administration bodies, their current administrative functions and the activities and improvement of the implementation of management procedures.*

**KEY WORDS:** *public administration, efficiency of public administration, project management, development institutions, crowdsourcing, strategic planning, assessment of authorities' performance efficiency, reform strategy, public sector of the economy.*

---

## I. INTRODUCTION

By the 21st century, the practice of applying effective administrative mechanisms to the system of public administration as a factor in the political, social and economic development of a democratic state is growing in the developed countries of the world community. This leads to the regulation of the civil service sectors, which requires the democratization of the relationship between the subject and the object of public administration processes, the evaluation of labor efficiency, the introduction of innovative approaches to governance. And there is a sharp increase in the need for training of professional managers who can control the indicative planning indicators of management. A new stage in the introduction of democratic features of the modernization of the public service delivery system is becoming more and more important.

In the experience of developed countries, special attention is paid to the use of management performance evaluation technologies to democratize public administration, the introduction of new mechanisms for outsourcing and contracting out services between the public and private sectors based on achieving target indicators. There are also some theoretical and practical problems with the use of innovative management technologies in public administration. Therefore, currently in the research of the world's leading research centers: prevent duplication of tasks, functions and powers between the institutions that make up the public

administration process; they focus on issues such as the abuse of power by some civil servants and the insufficient participation of civil society institutions in assessing the effectiveness of public administration.

From the very beginning of independence, one of the important tasks in Uzbekistan has been to create a national system of public administration based on the principles of equality and democracy in the international community. In this regard, the structure of public administration has been radically changed, the essence of which is enshrined in the Constitution of the Republic of Uzbekistan on the basis of national democratic principles. Today, the system of public administration in our country has entered a new stage of development. At this stage, "the introduction of a modern, rational system of governance is a prerequisite for fulfilling the tasks set before us"<sup>1</sup>. In this regard, one of the important tasks before us in the implementation of the priorities set out in the "Concept of Administrative Reforms" of the Republic of Uzbekistan is the formation of an effective system of public service, in the democratization of public administration processes, special attention is paid to the development of the organizational and legal framework for the clear definition of the roles, powers and responsibilities of each governing body<sup>[2]</sup>.





## II. DISCUSSION

Legal, political, and philosophical ideas for the study of the structure of the state and society, the system of governance, are also found in the works of thinkers of the ancient world. They were guided by a moral and philosophical view of the decision-making process of public administration through the prism of mythological interpretations.

Also of great importance are the scientific and practical research of European and American scientists who have conducted research on the subject, including: A. Fayol, M. Weber, L. Erhard, M. Oakshott, on the institutional and functional features of public administration. Certain scientific studies have been conducted by D. Mc.Gregor, A. Maslow, M. Duverger, D. Easton, and M. Croese[3].

At the same time, G.V. Atamanchuk-object and subject relations of public administration, A. Ya. Ponamareva - Conceptual bases of public administration, I.A. Vasilenko - Management Models of Developed Western Countries, V. Kozbanenko - issues of efficiency in public administration, V.I. Knorr-ing-management art and leadership factors, as well as G.L. Kupryashin's[4] scientific-theoretical approaches to specific models of democratization and modernization of public administration can be traced in their research. In this regard, the Russian scientist G.L. Kupryashin said: "The successful outcome of the modernization of public administration is determined by the fact that governance reforms - rational norms that can be adopted by the state apparatus, the public nature of the civil service, the high level of professionalism of civil servants: compliance with anti-corruption laws and normative restrictions on the management of various social interests in the process of governance," - he said confirms our views on the urgency of clearly defining the functions of public authorities, as well as the introduction of mechanisms aimed at improving their efficiency[5].

## III. RESULTS AND DISCUSSIONS

In studying the scientific and theoretical foundations of public administration, it is important to understand the essence of the concepts of "state" and "governance", which are its components. In particular, the concept of "governance" has been widely interpreted so far, and as a result, the concept today is based on an infinite variety of different characteristics, relationships, and processes. After all, the system of public administration, as long as it reflects the needs of society and the evolution of national interests, in order to know the scientific and methodological basis of the principles of organization of public administration processes, it is necessary to study in depth the methods of political research in this system. In particular, the study of the system can be used to achieve a sufficient degree of commonality with practical processes and to develop effective governance measures to further improve the system of public administration. This requires, on the one hand, a scientifically based practice

to carry out existing management tasks, and, on the other hand, the development of public administration theory and the systematic systematization of research findings in this area.

In this regard, it is worth noting that Uzbekistan has all the necessary opportunities for further development of practical reforms in public administration. One of these opportunities is, first of all, the availability of historical, political, legal, economic scientific sources on theories of public administration. Comprehensive study of political experience in the democratization of public administration today, in particular, the implementation of effective governance models and strategic development programs based on a comparative study of modern concepts of public administration, typical of Eastern and Western traditions, is necessary for the national development of each country, it is of both practical and theoretical importance.

Therefore, this chapter reveals the essence of scientific theories, approaches, practical concepts studied in the field of public administration to date, the methodological basis of democratic governance in developing countries. Also, the specific principles of democratization and modernization of public administration in Uzbekistan, the interpretation of the specifics of public administration will be improved from the point of view of political science, based on the task of ensuring balance and coherence between branches of government.

The desire to understand any modern socio-political process, in particular, systemic phenomena such as public administration, encourages us to address the nature and essence of the issue. Many socio-political processes that take place in society are inextricably linked with the issue of governance. In fact, the Latin "administratio" - the term "service" and "management" - means to lead (someone, something)[2]. Management is a universal and necessary feature of the world around us. Management is a necessity, without management it is impossible to direct the activities of people to the goal, to develop the relevant areas. Where there is no control, there is happen chaos.

In this regard, the study of public administration in terms of its essence, who belongs to power in the state, who is its subject, which state, first of all, represents and protects the interests of which stratum, group, class, its main components, internal structure, state power the main methods of implementation, i.e. how power is organized in a particular state? Which state bodies are governed? What are the procedures and powers of these bodies? requires finding reasonable answers to questions such as.

In the history of political and legal doctrines, there have been different approaches to such concepts as "state", "society", "governance", firstly, because of the socio-political situation that has prevailed in each epoch, and secondly, we can see that different criteria



are used as a basis. In particular, in a society organized by the state, who and how exercises state power determines the form of government of that state. This issue has been of interest to mankind for a long time, for example, in the ancient Greek political and legal doctrine of Democritus: "The common interest and justice are reflected in the state. The interests of the state take precedence over everything else, so the activities of citizens should be aimed at improving the state system and governance. The "good" are not the nobles and the rich of the past, but the high intellectual and moral. The state should be ruled by such people. Laws should serve the well-being of police officers. But people also need to work to achieve such a result. "They have to obey the law," he said[3].

The Republic of Uzbekistan, whose main goal is to build a just, humane, democratic state, free and prosperous life, said today that the introduction of modern methods of public administration aimed at achieving tangible results, in particular, "People should serve our people, not government agencies" is carrying out solid reforms on the way to the full implementation of the glorious idea. In this regard, "We are striving to build a civil society," said the first President of the Republic of Uzbekistan I.A. Karimov. This means that as our statehood develops, we will be handing over the various functions of government directly to the people, that is, further developing our self-governing bodies"[4].

Also, with his rich scientific and theoretical heritage, Plato, who made a significant contribution to the philosophy, political and legal doctrine of antiquity, in his work "The State" seeks to identify the causes of social inequality in society and reflects on building a just ideal state. Plato's society is divided into three classes: the philosophers who run the state, the military who defend the state, and the peasants and artisans whose job it is to meet the needs of society. According to him, "the state is ruled by wise philosophers, who develop scientific theories, understand the world and teach it to others. The military exercises, maintains order in the country, and participates in war when necessary. Farmers and artisans, on the other hand, engage in hard physical labor, create material wealth, and own a limited amount of private property only when necessary"[5].

From Plato's views on social inequality in society and the construction of a just ideal state, governance is the process of human consciousness, behavior, and it is a set of preferential measures aimed at regulating certain tasks. In this way, public administration is carried out within the framework of subjective factors, and it is the influence of public servants on others in the material, social, spiritual spheres, on those who are engaged in production. Also,

the development of the political, economic and social spheres of the country requires the implementation of modernization processes in all systems of governance in order to achieve high results in these areas. Of course, the realization of these huge goals is largely determined by how well the management staff meets the requirements of the modern world. In general, the effectiveness of all sectoral mechanisms in society is also measured by the readiness of management personnel to the current conditions. In particular, the areas of leadership, including management, planning, organization, decision-making, public service delivery, directly depend on the methods of implementing technologies to implement innovative targeting strategies of management personnel policy.

In the Middle Ages, for example, ideas about the state, society, and justice were widely propagated, especially by Central Asian scholars. The great scholar Abu Nasr al-Farabi, for the first time in Eastern philosophy, emphasized the need to establish a just government in the country in order to build a noble society. His works, such as "The City of Noble People", "The Book of Laws", "The Booklet on the Ways to Happiness", "The Management of the City" and "Virtuous Behaviors", its function, the origin, composition and types of public associations are described, and the forms of human society are discussed. The scientist was a city-state in his time; the peculiarities and life of the state union; functions of the state and forms of its management; the tasks and ultimate goal of the state association; clarifies concepts such as ways and means of achieving overall integration.

Farabi sees the emergence of the state and its activities as a result of the people's natural desire to unite. He knows that the ultimate goal of everyone is to achieve happiness. Farabi argues that the normal existence of a state depends in many ways on how it is governed, so he attaches great importance to the personality of the ruler. The ruler, according to Farabi, had certain intellectual and moral qualities; must know the general laws of governance and be able to follow the people of his country and lead them to the common good. When thinking about the forms of government, Farabi lists the internal and external functions of the state. The effectiveness of these functions (ensuring the happiness of internal citizens; out-of-town protection) depends on the rational organization of governance. Farabi includes such forms of government as monopoly, the rule of the country by a small group, and the power of a ruler elected by the people. "Only sound politics strengthens human rights and responsibilities in society," he said[6].

Indeed, the essence of the state is characterized primarily by its interaction with society, the implementation of such functions as the regulation and improvement of private, collective and social life of the people. After all, the social function of the state is a



form of its legal relationship with society. One of the forms of decision-making of the foundations of statehood is the "social state", which in this regard implements its goals and principles on the basis of the rule of law. At the same time, the traditions of "noble city" and "noble society" put forward in Farabi's views on the formation of the foundations of civil society, the expansion of human rights and freedoms and the filling of legal norms with the content of justice are specific to the "socio-legal state" reflected in goals and objectives[7].

The development of the socio-legal state was further intensified in 1960-1975 with the introduction of minimum social standards by the European Social Charter and the International Covenants on Economic, Social and Cultural Rights.

By this time, the social state began to be described as a model of government based on the social security of the individual. The basis of such a state is the principle of "civil society". Since that time, the socio-legal state has been recognized as a political institution that creates a stable legal, economic and social environment for civil society[8]

Nizamulmulk, who has left an indelible mark on the history and culture of the East with his work *Siyasatnoma* (or *Siyar ul-muluk*), connects the foundations of society with social development and moral values. He taught that "a ruler who is just and upright, wise and merciful, pure and upright, a happy society is one in which the country is prosperous, civilized, peaceful, and wisely governed by strict discipline." Indeed, the main feature of a society is its organic integrity, its systemicity, the extent to which people are able to unite on the basis necessary for the common purpose of living in it. The main characteristics of any society are: a nation that has historically emerged; commonality of territory; certain ways of life; regulation of economic, social and political relations; common language, spiritual culture and traditions; factors such as the organization of power and governance.

We believe that while the state remains the leading element of society, the attitude of the ruling class to the duties and responsibilities in this regard, honesty, morality, the image of the state, through which it has a strong impact on the sustainable development of society. In this regard, the civil service is a type of activity, the results of which can not be measured by the amount or volume of documents prepared and received by employees, the time spent on their work. The civil service is a kind of social relationship in which the government performs the function of organizing and managing its social processes, human activities and behavior. In fact, the first President of the Republic of Uzbekistan Islam Karimov said in his speech at a special session of the Surkhandarya Regional Council of People's Deputies on June 1, 2004:

"When will a leader gain the trust and attention of the people?" When he has a pure heart, pure hands, open mind, intellect and intelligence, his nature is one of perseverance, of knowledge, of perseverance and justice, if he is able to take the worries of the people he controls into his own heart.[9]"

The great scholar Hussein VaizKashifi, for example, said, "The state and society cannot be imagined without politics and governance, for without them it is impossible to carry out the task of regulating the important affairs of the world, the absence of laws on education and punishment leads to the disruption of state activity." In doing so, the author is talking about two forms of government: controlling one's own heart and controlling one's subordinates. According to the thinker, "without governance in society, there can be no mutual support, because everyone harms others for their own benefit, and vices such as strife, violence, and violence abound.[10]

It can be concluded from the thoughts of the thinker that, the concept of "governance" is based solely on administrative power, not through the use of power, but through the stimulation of this concept, it is also a factor influencing people's behavior, attitudes, and activities. The nature of "governance" in this sense is creativity, practical cooperation and is aimed at the development of society and the implementation of the tasks facing the country. Therefore, in order to properly understand public administration, it is necessary to take into account the characteristics of the interaction of the parties involved. The Constitution of the Republic of Uzbekistan states: "The Republic of Uzbekistan determines its national state and administrative-territorial structure, the system of state power and administration, implements domestic and foreign policy ..."[11]. In this sense, public administration can be considered as a "subject of government" ("system of government"), that is, the interdependence of the "subject of government" is reflected in the social system (managed spheres of life). This requires knowledge of the laws of the object to be controlled, the object and conditions of the organization, before the effect. In such a system, the subject of government, the state, through the state apparatus, defines the functions of the state's influence and determines its legal forms. Society, on the other hand, shapes the content of interactions and brings together the relationship between laws, interests, and needs (the controlled entity) and the capabilities (resources) of the governing entity.

#### IV. CONCLUSION

When we make a comparative analysis of the evolution of the state, society and the phenomenon of governance, we summarize them: 1) patriarchal (R.





Filler); 2) theocratic; 3) violence (E. Durand, L. Gumplovich); 4) social contract (G. Grotius, J. J. Russo, J. Locke); 5) organic dependence (D.J. Fortesky, A. Sheffl, R. Worms); 6) psychological (J. Burdo); 7) can be divided into scientific theoretical directions, such as political anthropology. Such approaches have a specific meaning and, from the point of view of the political approach - the common feature of the state and society - are seen as a means of solving certain economic, social, political goals and objectives [16]. In doing so, the state regulates the relationship between the government and the people, the ruler and the governed. Indeed, in the current era of "state-society-individual" balance, which is based on a special administrative apparatus of government-state-wide, a political organization that legislates for all and has its own sovereignty." It is the reflection and improvement of the functional nature of public administration and the need to analyze the activities of modern scientific schools in determining its main directions and goals. The scientific and practical concepts developed in Western schools in France, Germany, the United Kingdom and the United States are of particular importance in the study of public administration. In particular, A. Fayol is recognized as a classic representative of the theory of public administration in France. His views and analysis of management are set out in his 1916 book, "General and Industrial Management". A. Fayol gives a classic definition of scientific management: "Management means foresight (predictive function), organization, command, coordination and control." Fayol, showing the important functions of management: foresight is the development of a forward-looking action plan; organization - that is, the organization of the material and social organism of the organization; command-encouragement of employees to approach functional labor activity; coordination - coordination of management activities; to ensure that control and management activities are carried out in accordance with established and established norms. 12

According to Fayol's view, the management of any organization consists of the following set of functions: technical, commercial, financial, insurance, accounting and administrative methods. Among these functions, Fayol recognizes the "administrative function" as the main function, noting that none of the remaining functions perform the functions of creating an overall program of work of the organization, gathering workers, distribution of forces. All of this is part of one function, the "administrative function." That is why this function is the leading function.

In our opinion, in order to form the criteria of administrative function, it is necessary to first identify all the problems that exist in the system of public administration, the issues that need to be addressed. The first of these, as noted by the President of the Republic of Uzbekistan Sh. Mirziyoyev, is the

problems in the "system of communication between government agencies and the public." In particular, the factors that create a negative attitude of the population towards public authorities and officials are: 1) "alienation from the people"; 2) "the big difference between words and deeds (hypocrisy)"; 3) "corruption". Therefore, in order to eliminate such factors, first of all, reforms in public administration should be considered as a priority, such as defining specific areas of administrative functions, increasing the initiative and role of public authorities in shaping state and regional development programs.

## V. REFERENCES

1. *Ўзбекистон Республикаси Президентининг Шавкат Мирзиёевнинг Олий Мажлисида Мурожаатномаси*. -Т.: 28.12.2018 й. // Манба: [https://president.uz/uz/lists/view/2228Ўзбекистон\\_Республикаси\\_Президентининг\\_расмий\\_веб-сайти](https://president.uz/uz/lists/view/2228Ўзбекистон_Республикаси_Президентининг_расмий_веб-сайти).
2. *Ўзбекистон Республикаси Президентининг 2017 йил 8 сентябрдаги "Ўзбекистон Республикасида Маъмурий ислохотлар концепциясини тасдиқлаш тўғрисида"ги ПФ-5185-сон Фармони*. Т.: "Халқ сўзи" газетаси, 2017 йил 9 сентябрь, 180 (6874)-сон.
3. А.Файоль. *Управление-это наука искусство*, -М.: Республика, 1992.; М.Вебер. *Spanmmgen und Krafte im Westdeutschen Verfassungssystem*. Humbolt, 1970.; Л.Эрхард. *Burokratie und Politik: Zur Struktur und Funktion der Ministerialburokratie in der Bunderrepublik Deutschland*. Munchen: Fink, 1975. P. 223.; М.Оукишотт. "Rationalism in Politics and other Essays". L., 1962. P.184.; Duverger M. *Institutions politique et droit constitutionnel*. Paris, 1970. P.7.; Easton D. *Behaviouralism//Contemporary Political Analysis*. N.Y.; L., 1967. P. 12.; А.Маслоу. "Public Administration: Agencies, Policies and Politics". N.Y.; San Francisco, 1982. P. 211.; D.McGregor. *From Human Side of Enterprise*. McGraw-Hill Book Company, 1960.
4. Атаманчук Г.В. *Теория государственного управления: Учебник*. -М.: "Омега-Л", 2009.; А.Я.Понамарева "Государственное и муниципальное управление" М.: "С-П", И.А.Василенко. *Административно-государственное управление в странах Запада: США, Великобритания, Франция, Германия: Учебное пособие*. Изд. 2-е, перераб. и доп. -М.: Издательская корпорация "Логос", 2001. С.200.; В.И.Кнорринг *Теория, практика и искусство управления*. -М.: "Норма", 2001. С.528.; Козбаненко В. *Государственное управление: основы теории и организации*. -М.: "Статут", 2002.
5. Купряшин Г.Л. *Политика-административные институты модернизации государственного управления*. -М.: МГУ, 2013. -С.434.
6. Рахмонов А. "Ўзбекистон Республикасида давлат бошқаруви". -Т., "Академия". 2007 йил. 6 - бет.



7. Мухитдинова Ф. “Сиёсий ва ҳуқуқий таълимотлар тарихи”. Дарслик. -Т., ТДЮУ. 2011. Б.52.
8. Каримов И.А. Ўзбекистоннинг сиёсий-ижтимоий ва иқтисодий истиқболининг асосий тамойиллари. 3-жилд, Т.: “Ўзбекистон”, 1996. - Б.11.
9. Платон. Государство. // Пер. с древнегреч. А.Н.Егунова. Вступ. ст. Е.Н.Трубецкого. Комментар. В.Ф.Асмуса. Примеч. А.А.Тахо-Годи. -М.: “Академический проект”, 2015.(Философские технологии). С.378.
10. Абу Наср Форобий. “Фозил одамлар шаҳри” (Танланган асарлар). Т., А.Қодирйи номидаги халқ мероси нашриёти, 1993. - Б. 159-161.
11. Абу Наср Форобий. “Фозил одамлар шаҳри” (Танланган асарлар). Т., А.Қодирйи номидаги халқ мероси нашриёти, 1993.
12. Идея правового государства: возникновение и развитие. // <http://mir.zavantag.com/pravo/17094/index.html>.
13. Қонун ва адолат устуворлиги фаолиятимиз мезони бўлсин. Ўзбекистон Республикаси биринчи Президенти Ислам Каримовнинг халқ депутатлари Сурхондарё вилояти Кенгашининг навбатдан ташқари сессиясидаги нутқи. // “Халқ сўзи” газетаси. 2004 йил 2 июнь.
14. Муҳиддинова Ф. “Адолатнома” // “Ҳуқуқ ва бурч” ижтимоий ҳуқуқий журнали № 12. -Т.: 2008 Б.3.
15. Ўзбекистон Республикасининг Конституцияси. -Т.: Ўзбекистон, 2017.3-модда.
16. Управление- это наука и искусство /А. Файоль, Г. Эмерсон, Ф. Тейлор, Г. Форд. М.: Республика, 1992. С. 12.





## WORKFORCE DESIGN AND EMPLOYEE PERFORMANCE IN THE HOTEL INDUSTRY IN KISUMU COUNTY, KENYA

David Ochieng Osir<sup>1</sup>, Eglay Tsuma<sup>2</sup>, Willis Otuya<sup>3</sup>

<sup>1,2,3</sup>School of Business and Economics, Masinde Muliro University of Science and Technology

### ABSTRACT

*The expanding role of the hotel industry as a global multi-cultural and multi-faceted sector cannot be underestimated. Most developing countries have embraced this sector as a critical source of revenue necessary for economic growth. However the work environment in which employees are expected to achieve globally accepted standards in service delivery has largely been given very limited research focus in Kenya. The main objective of this paper was to determine the effect of work design on employee performance in the hotel industry in Kisumu County. The target population was 345 derived from a sample frame of three 4-star hotels in Kisumu County, selected through purposive sampling. The sample size of 104 was derived as 30% of the target population. Questionnaires and interview schedules were used to collect data. Data was analyzed using descriptive and inferential statistics. Findings indicated that at 5% level of significance, work design was a significant predictor of employees' performance in the hotel industry in Kisumu County where ( $p=0.006 < 0.05$ ). These findings would enable researchers and policy makers to implement policies and practices as organizational factors that can impact significantly on the work environment and the overall performance of employees in the hotel industry and recommended the need to put in place structures that support these practices as a necessary component in the emerging hotel related businesses.*

**KEYWORDS:** Employee performance, Work design

### 1. INTRODUCTION

The relationship between work environment and employee performance has continued to elicit debate among academics and policy makers across the hotel-related industry in most developed countries. This industry is no doubt characterized by higher rates of occupational injury and stress related illnesses compared to any other service sectors. Globalization and increased use of technology has brought tremendous change in the hotel sector and created new demands for the business world therefore changing the strategic intention of organizations in the achievement of strategic goals in this sector (Heng, 2012).

The evolving nature of the work setting in the hotel industry continues to transition into a stronger service economy, according to Vischer (2008), which means that the numbers of women in the employee population are growing and that many older employees stay in jobs for longer periods. For productive, safe, healthy workers, the necessity for good work design or good job design is crucial. It's also important to remember that most workers rely less and less on the physical aspects of employment, but rely more on the use of mental processes. There is also the idea that the

distinctions between mental and physical activities are fuzzy as work becomes more complex. Globalization, lean development, automation, the transition from single-handed to complex tasks and upgrading jobs to increased educational levels among employees all have an effect on the context and the difficulty of work and jobs. These factors are not static, and so the dynamics of employment and work are changing and the meaning of work will continue to change as societies change (Hammeed, *et al.*, 2009).

### 2. STATEMENT OF THE PROBLEM

The hospitality industry is manpower-intensive and the performance of employees determines its profitability. Employees working in the hotel industry are often subjected to uncertainties occasioned by changes in the external and internal business environments. When this happens, the employees in the hotel industry are usually the first casualties; exposed and demoralized through massive lay-offs and restructuring. The overall profitability of the hotels depends on the service quality provided by the hotels to the customers. Thus, this paper sought to investigate



work study design that are consistent with employee performance.

### 3. LITERATURE REVIEW

Work design is also known as job design or job design. It is a central feature of the management of human resources related to the concept of work contents, strategies and connections in order to meet technical and organizational requirements as well as the social and personal needs of the work (Armstrong, 2006). Job design is a workplace arrangement intended to resolve employee alienation and work dissatisfaction arising from repetitive mechanical work at the workplace. Organizations use job design to improve productivity through the provision of non-monetary incentives for workers (Hammed, *et al.*, 2009).

Job design is used to determine how activities or job in the working environment are designed and ensures that they are well associated with employee characteristics. Whereas both terms, job design, and workplace design are used interchangeably, the work design focuses on administrative improvements needed to improve working conditions, with a more realistic approach to work design and the modifications necessary for workplaces, equipment and body positions to make the worker work more efficiently (Aston, 2005)

The correctly developed job ensures that the staff are able to perform what is needed safely and in health, while minimizing physical and psychological pressure (Leblebici, 2012). It also helps to coordinate work, recognize problems like work overload, repetitiveness, and a restricted control of the work; and thus improves the organization's occupational health and safety (OSH). A well-designed job could result in more committed, safe and efficient workers, and both employees and organizations would benefit from this (Roeloelefsen, 2002).

### 4. RESEARCH METHODOLOGY

#### 4.1 Research Design

The study used a causal research design to determine the effect of work environment on employees'

performance in the hotel industry in Kisumu County in Kenya. According to Mugenda and Mugenda (1999), causal research designs are used in preliminary and exploratory studies to allow researchers to determine the relationship between two or more variables. It plays an important role in determining the reasons behind a wide variety of processes and is correlated with a higher degree of internal validity due to the systematic selection of subjects.

#### 4.2 Study Area

The study was carried out in Kisumu County, which is located in the former Nyanza Province, with a population of 968,909 (Census, 2009) covering an area of 2085,9 km<sup>2</sup>. It borders Siaya County to the West, Vihiga County to the North, Nandi County to the North East and Kericho County to the East. It has a coastline on Lake Victoria occupying the North, West and part of the Southern coast. It has a population density of 460 per square kilometer. The county extends from the Nandi Escarpment in the East to the Kano plains in the West with annual relief rainfall of between 1200 mm and 1300 mm. The region is warm all year round with average annual temperatures of 23 to 35 C (Kisumu County, 2014). The county has many hotels, many operated by private investors. This area was chosen for this study due to the high presence of tourism and industry, the presence of hospitality facilities and workers, the high rate of urbanization and the proximity of the researcher.

#### 4.3 Study Population

The study population consisted of 345 employees employed in selected 4-star hotels in Kisumu County, Kenya. The target population for this analysis has been drawn from the top. Middle and low-level management Part-time employees and support staff employed in these hotels will not be included in the study (Kenya Tourism Sector Report).



**Table 1: Target Population for 4-Star Hotel staff in Top-Level Management, Middle-Level Management and Low-Level Management in Kisumu County, Kenya**

Hotel	Top-Level	Middle-Level	Low-Level
Kisumu Hotel	10	35	60
Acacia Hotel	10	30	55
Imperial Hotel	5	30	50
Le Savannah Hotel	5	20	35
<b>Total</b>	<b>30</b>	<b>115</b>	<b>200</b>

Source: Kenya Tourism Sector Report (2018)

#### 4.4 Sampling Frame, Sampling Procedures and Sample Size

Purposive sampling would be used to select four 4-star hotels public health care institutions as follows; Kisumu Hotel, Acacia Hotel, Imperial Hotel and Le Savannah These hotels have been in existence for more than five years and are more likely to encounter work environment related aspects.

Stratified random sampling was used to identify respondents to participate in the study. The sample structure included a list of employees who operated selected Hotels at the top, mid- to low-level, stratum. In

each stratum, a simple random sampling approach was used to select respondents to participate in the sample. Each employee would be allocated a unique identification number and, using a random number table, the respondents would be chosen to achieve a high degree of representation and to minimize bias.

The sample size was obtained using a formula developed by Kerlinger (1993) which states that 30% of the target population is representative enough for any given study. The sample size was therefore 104 respondents.

**Table 2: Sampling Matrix for Top, Middle and Low Level Management in the Selected Hotels in Kisumu County**

Level	Target Population	Sample
Top level	30	9
Middle level	115	35
Low level	200	60
<b>Total 345</b>	<b>N</b>	<b>Total =104</b>

Source: Researcher (2019)

#### 4.5 Data Collection Methods

The research used qualitative as well as quantitative data. The analysis focused on primary and secondary data. Primary data was obtained through standardized questionnaires, which would provide respondents the ability to provide accurate information. In comparison, secondary data was obtained from a variety of sources such as journal archival records, policy papers, Legislative acts, official reports, the Internet and other related literature.

### 5. RESULTS

The study used the parameters where: 1= Strongly Disagree (SD), 2 = Disagree (D), 3=Undecided (U) , 4 = Agree (A) and 5= Strongly agree (SA). A summary of the findings is as shown in Table 4.13. The respondents agreed (45.0%) that their work is designed to allow for participation in decision making as depicted by a mean of 4.13 and standard

deviation of 1.192. 37.0% of the employees agreed that their work is meaningful in terms of building relationships. On the other hand, 35.0% of the respondents agreed that duties and responsibilities assigned to the employees match their skills and qualifications, while 35.0% were undecided on responding on whether their employers provides training opportunities on new technologies. Respondents (29.0%) agreed that flexible work schedules have been put in place by management, while 35.0% agreed that their workplace gives them opportunities for direct feedbacks from clients and stakeholders. Lastly, 32.0% and 33.0% of the respondents strongly agreed that their workplace allows for self-managing teams and agreed that their employers allows coordinated flow of critical information respectively.



Table 4.2: Responses on Work Design

	N	SD (%)	D (%)	U (%)	A (%)	SA (%)	Mean	Std. Dev.	Max	Min
My work is designed to allow for participation in decision making	100	11 (11.0)	13 (13.0)	18 (18.0)	45 (45.0)	13 (13.0)	4.13	1.192	5	1
My work is meaningful in terms of building relationships	100	11 (11.0)	10 (10.0)	29 (29.0)	37 (37.0)	13 (13.0)	4.09	1.113	5	1
The duties and responsibilities assigned to me match my skills and qualifications	100	8 (8.0)	18 (18.0)	27 (27.0)	35 (35.0)	11 (11.0)	4.01	1.142	5	1
My employer provides training opportunities on new technologies	100	17 (17.0)	26 (26.0)	35 (35.0)	17 (17.0)	5 (5.0)	3.99	1.089	5	1
Flexible work schedules have been put in place by management	100	11 (11.0)	18 (18.0)	28 (28.0)	29 (29.0)	14 (14.0)	4.02	1.136	5	1
My workplace gives opportunities for direct feedback from clients and stakeholders	100	9 (9.0)	14 (14.0)	28 (28.0)	35 (35.0)	14 (14.0)	4.14	1.309	5	1
My workplace allows for self-managing teams	100	11 (11.0)	11 (11.0)	18 (18.0)	28 (28.0)	32 (32.0)	4.15	1.147	5	1
My employer allows coordinated flow of critical information	100	11 (11.0)	12 (12.0)	24 (24.0)	33 (33.0)	20 (20.0)	4.05	1.073	5	1

Source: Researcher (2020)



A well-designed job could result in more engaged, healthy and productive employees, and these outcomes would benefit both employees and organizations (Roelofs, 2002). Work design is mostly in terms of non-monetary benefit, and hence better work overload and limited control over work will result in employees' work performance.

**Hypothesis 1: Workforce Design and Employee Performance**

To determine whether workforce design had significant influence on employee performance, hypothesis testing is done.

$H_{01}$  Work design has no significant effect on employees' performance in the hotel industry in Kisumu County

**Table 4.3: Model Summary**

Model	R	R Square	Adjusted R Square	Std. Error of the Estimate
1	.510 <sup>a</sup>	.429	.827	1.70112

Source: Researcher (2020)

From the study findings in Table 4.19, the value of R-square is 0.429. This implies that, 42.9% of variation of employees' performance in the hotel

industry in Kisumu County was explained by work design.

**Table 4.4: ANOVA Test**

Model		Sum of Squares	Df	Mean Square	F	Sig.
1	Regression	1149.030	1	1149.030	397.067	.002 <sup>b</sup>
	Residual	237.291	99	2.894		
	Total	1386.321	100			

a. Dependent Variable: employee performance

b. Predictors: (Constant), Work design

Source: Researcher (2020)

From the findings in Table 4.20, at 0.05 level of significance the ANOVA test indicated that in this model the independent variable namely; work design is important in predicting of employees' performance in

the hotel industry in Kisumu County as indicated by significance value=0.002 which is less than 0.05 level of significance ( $p=0.002 < 0.05$ ).

**Table 4.5: Coefficients of the Model**

Model		Unstandardized Coefficients		Standardized Coefficients	T	Sig.
		B	Std. Error	Beta		
1	(Constant)	4.476	.712		6.285	.000
	Work design	.310	.026	.910	19.927	.002

a. Dependent Variable: Employee performance

Source: Researcher (2020)

From Table 4.21, the study findings revealed that work design had significant influence on employees' performance in the hotel industry in Kisumu County ( $t$ -statistic=19.927,  $p$ -value=0.002 < 0.05). Therefore at 5% level of significance the null hypothesis was rejected, indicating that work design has a significant relationship with employees' performance in the hotel industry in Kisumu County. Thus, for every unit increase in work design there was

a corresponding increase on employees' performance in the hotel industry in Kisumu County by 0.310. These findings are supported by Heng (2012) and Elzeiny (2013) who observed that there is a positive link between work environment and work design with employee satisfaction.





## 5.1 CONCLUSIONS

The study has provided evidence that work design had a significant effect on employees' performance in the hotel industry in Kisumu County and that it played a role in supporting them to attain their organizations' strategic goals and vision. The study provided evidence that workforce diversity is critical in depicting employees' performance in the hotel industry in Kisumu County and that it had a significant effect on their performance.

## 5.2 RECOMMENDATIONS

Work design is critical and forms an integral part in supporting the HR department in the allocation of duties and responsibilities in order to achieve an attractive work environment. Workforce diversity for hotel workers that is comprehensive in nature would lead to the introduction of innovation, tolerance in understanding different cultures, reduced employee turnover, quality service provision and higher employee output.

## REFERENCES

1. Armstrong, M. (2006). *Strategic Human Resource Management: A Handbook of Human Resource Management Practice, 10th ed.* London: Kogan Page.
2. Aston, C.E., & Ashkanasy, N.M (2005). *What Lies Beneath? A Process of Analysis of Affective Events Theory, The Effect of Affect in Organizational Settings Research on Emotion in Organizations, Vol.1 pp. 23-46*
3. El-Zeiny, R.M.A. (2013), *Interior Design of Workplace and Performance Relationship: Private Sector Corporations in Egypt, Asian Journal of Environment-Behavior Studies, Vol.4, No. 11*
4. Hameed, Amina & Amjad, Shela. (2009). *Impact of office design on employees' Productivity: A case study of Banking Organizations of Abbottabad, Pakistan. Journal of Public Affairs, Administration and Management, 3(1), 2009. Retrieved August 8, 2015 from <http://www.scientificjournals.org/journals>*
5. Heng, T.B., (2012). *The Reward Strategy and Performance Measurement (Evidence From Malaysian Insurance Companies), International Journal of Business, Humanities and Technology, Vol. 2, pp. 211-223*
6. Leblebici D., (2012), *Impact of Workplace Quality on Employee's Productivity: Case study of A bank in Turkey, Journal of Business, Economics and Finance, ISSN 2146-7943, Volume 1 issue 1 p.p. (38-49)*
7. Mugenda, M. and Mugenda, G. (2003), *Research Methods, Quantitative and Qualitative Approaches, Nairobi, Acts Press.*
8. Roelofs, P. (2002). *The impact of office environments on employee Performance: The Design of the Workplace as a Strategy for Productivity Enhancement. Journal of Facilities Management, Vol-1 (3), 247-264.*
9. Vischer, J.C. (2008). *Towards an Environmental Psychology of Workplace: How People are Affected by Environments for Work. Journal of Architectural Science Review, 56 (2), 97-105.*



# ANALYSIS OF EXPERIENCE OF FOREIGN COUNTRIES IN ENSURING PUBLIC SAFETY

UO'K: №: 64.3. M 64.

**Haydarov Alisher Usmon o'g'li**

*Researcher of the University of Public Safety of the Republic of Uzbekistan*

Article DOI: <https://doi.org/10.36713/epra3602>

DOI No: 10.36713/epra3602

## ANNOTATION

*Each state on the basis of its locality and standards of life strives to ensure peace and tranquility, the rights and interests of citizens, public order and the prevention of violations. For this purpose all countries have structural units responsible for internal security. This article explores best practices of such developed countries as Russian Federation, United States of America, Japan and China in the sphere of public security and relevant suggestions are formulated for further improvement of the activity of National Guard of the Republic of Uzbekistan in this direction.*

**KEYWORDS:** National Guard, public order, public security, administrative territory, locality, maintenance of public order and security, preventive measures, interaction with the public, police stations and posts, commissioner of police, policeman, patrol and post service, sheriff.

## INTRODUCTION

Ensuring public safety and providing a comfortable life for the population have been the main issues since the origin of the human society. Particularly, the ongoing struggles between ideas and ideologies during globalization and in the age of information are leading to a number of problems in ensuring public safety. In the world, each state has its own experience in ensuring public order and security and the use of these experiences in Uzbekistan contributes to the improvement of this system.

## LITERATURE REVIEW

Research has been conducted in a number of foreign countries on the issue of public safety, the historical experience of its provision, the experience of ensuring public safety. These issues can be seen in the works of such researchers Voronov A.M.<sup>1</sup>,

<sup>1</sup> Voronov A.M. Obshestvennaya bezopasnost': Administrativnie i informatsionno-pravovye problemi obespecheniya. Avtoreferat dokt. diss. jurid. nauk. – M.:2005. – 56 s. URL: <https://www.dissercat.com/content/obshchestvennaya-bezopasnost-administrativnye-i-informatsionno-pravovye-problemy-obespecheni>

Makarychev I.Yu<sup>2</sup>, Belsona Ya.M, Bogdanova V.N, Bykova A.V, Veremeenko I.I, Gilensena V.M<sup>3</sup>, Belsona Ya.M., Gilensena V.M, Gubanova A.B<sup>4</sup>.

## MAIN PART

In the framework of the administrative territory (settlement) of any nation, activities to maintain public order and ensure public safety are carried out in different ways. Each country has its

<sup>2</sup> Makarychev I.Yu. Administrativno-pravovoe obespechenie obshchestvennoy bezopasnosti organami munitsipal'noy vlasti. Avtoreferat diss. kand. jurid. nauk. – Lyuberski:2010. – 32 s. URL: <https://www.dissercat.com/content/administrativno-pravovoe-obespechenie-obshchestvennoi-bezopasnosti-organami-munitsipalnoi-vl/read>

<sup>3</sup> Smorodinskova Irina Aleksandrovna Organizatsionno-pravovie osnovi deyatelnosti Natsional'noy gvardii v obespechenii natsional'noy bezopasnosti SShA tema dissertatsii i avtoreferata po VAK RF 12.00.14, kandidat juridicheskikh nauk

<sup>4</sup> Bikov, Andrey Viktorovich Organizatsionno-pravovie osnovi deyatelnosti jandarmerii zapadnoevropeyskikh gosudarstv v obespechenii obshchestvennoy bezopasnosti tema dissertatsii i avtoreferata po VAK RF 12.00.02, kandidat juridicheskikh nauk



own experience in this area, and studying these experiences is one of the main requirements of the present day. The study of such experience provides an insight into the strengths and weaknesses of national structures aimed to ensure public safety. According to Vasilev D.V. studying the foreign experience, studying the factors influencing social development, determining the fundamental rules of development of society and its subsystem elements, and determining the prospects of the dynamics of social relations will create conditions to identify effective measures to address existing problems.<sup>5</sup>

According to Sharixin A.E, public security is a strategic priority of state national security<sup>6</sup>. The system of ensuring the public safety of developed countries differs from each other. The Russian Federation in this area has a great experience and the results of studying this experience allow us to come to conclusions to a certain extent.

In the Russian Federation (hereinafter referred to as Russia), "territorial police stations" play a significant role in maintaining public order and preventing disorders. The main purpose of organizing the service at such stations is to improve cooperation with public organizations and government agencies on the territories. Territorial police stations provide coordinated activities with self-governing bodies and the labor communities that are part of it. One of the main subjects of these stations is the police officers of the stations. Their activities are organized based on the decree of the Ministry of Internal Affairs of Russia (hereinafter - the Ministry of Internal Affairs) № 1166 "On the organization of the activities of police station inspectors" dated December 31, 2012.<sup>7</sup>

The activity of police inspectors is a guarantee of the protection of citizens from various criminal threats in their places of residence. In the legal-normative documents of Russia indicated that the main service time of the police officers should pass in the areas under their primary duty, if necessary, they should be organized in the local police stations. In some regions of Russia, the post of assistant police inspector has been introduced, which increases the efficiency of work as a result of the

distribution of workload.<sup>8</sup> The results of a survey of public opinion on police activities in the Russian Federation indicate that 83,3% of the population considers themselves protected from encroachments on life, health, and property, 87,3% expresses confidence in the ensuring security of personal and property to police inspectors.<sup>9</sup>

It is envisaged to involve citizens in the maintenance of public order and security, and an appropriate legal framework has been created to implement it. The role of patrol post-service inspectors in ensuring public order and security within the administrative regions is great. By patrolling in their territories, they ensure the identification of possible crime scenes, the identification of hidden criminals, cases of violation of the norms of law and morality by individuals, and the adoption of appropriate measures.<sup>10</sup>

The establishment of the Federal Service of the National Guard Troops of the Russian Federation by the Decree of the President of the Russian Federation No. 157 of April 5, 2016, led to public security in the Russian Federation to a new level.<sup>11</sup>

At present, the troops of the Russian National Guard, along with the police, are involved in maintaining public order and ensuring public safety. National Guard officers have broad authority in this regard. These include demanding from citizens to comply with public order and stop illegal actions, to take measures to protect the scene of the incident, prevent mass violations in the settlements of the people, and, if necessary, in the penitentiaries.

Although these powers of the Russian National Guard officers and militaries are close to the powers of the police, they have particular peculiarities. Citizens who have not fulfilled the legal requirement of the National Guard military

<sup>5</sup> Vasil'ev D.V. *Konsepsiya organizatsii deyatel'nosti polisii i vozmozhnosti ix ispol'zovaniya v otechestvennoy praktike: po materialam SShA i nekotorykh stran Zapadnoy Yevropi. Avtoreferat dissertatsii kand. yuridicheskix nauk.* – M., 2005.

<sup>6</sup> Sharixin A.E. *Obshestvennaya bezopasnost' kak strategicheskii prioritet nasional'noy bezopasnosti Rossii: vibor puti // Vestnik Moskovskogo universiteta MVD Rossii.* № 6, 2015. – S. 238-243.

<sup>7</sup> Ziyadullaev M.Z. *Zarubejnyy opit sistemi oxrani obshestvennogo poryadka i profilaktiki pravonarusheniy v naselennix punktax // Jurnal zarubejnogo zakonodatel'stva i sravnitel'nogo pravovedeniya* № 2, 2017. – S. 21-34.

<sup>8</sup> Buxarov D.Z. *Jinoyatchilikning oldini olishda jamoatchilik ishtiroki: jahon tajribasi // Milliy qadriyatlar va shaxs ijtimoiy himoyasining huquqiy mexanizmlarini takomillashtirish: Respublika ilmiy-amaliy konferensiyasi materiallari.* – Toshkent, 2007.

<sup>9</sup> *Federal'naya sluzhba voysk Nasional'noy gvardii Rossii. Voprosi uchastiya v oxrane obshestvennogo poryadka i obespechenie obshestvennoy bezopasnosti [Elektronniy resurs] – Rejim dostupa: [https:// cyberleninka.ru](https://cyberleninka.ru).* – Data obrasheniya: 12.05.2020

<sup>10</sup> Ziyadullaev M.Z. *«Zarubejnyy opit sistemi oxrani obshestvennogo poryadka i profilaktiki pravonarusheniy v naselennix punktax» Jurnal zarubejnogo zakonodatel'stva i sravnitel'nogo pravovedeniya* № 2, 2017 g. Buxarov D. Z. *«Jinoyatchilikning oldini olishda jamoatchilik ishtiroki: jahon tajribasi» Milliy qadriyatlar va shaxs ijtimoiy himoyasining huquqiy mexanizmlarini takomillashtirish: Respublika ilmiy-amaliy konferensiyasi materiallari.* Toshkent, 2007 y.

<sup>11</sup> *Obzor rezul'tatov oprosa obshestvennogo mneniya o deyatel'nosti polisii (2019 god) [Elektronniy resurs] – Rejim dostupa: [https:// mvd.rf.ru](https://mvd.rf.ru).* – Data obrasheniya: 08.05.2020.



officer (personnel) are subject to administrative responsibility in the form of fines or arrest.<sup>12</sup>

The United States of America (hereinafter referred to as the US) is a country with a unique system and experience in maintaining public order and security in administrative-territorial units. The US police have a decentralized management system, which is based on the principle of "bottom-up", unlike European police systems.<sup>13</sup>

D.D.Shalyagin noted that having such a system of the American police is characterized by the history of the emergence of statehood on North America.<sup>14</sup>

Most local police agencies consist of sheriff's departments of the states. The sheriff is a reliable representative of the police, performing certain administrative functions in his district. The sheriff is an official who ensures public order and security in territories, the prevention of crimes, the establishment of anti-crime and the execution of punishment. Being responsible for the state of public order in the administrative territory, the sheriff has almost all legal powers. His activities are funded by the local budget.

In the major states of the United States, sheriffs are provided with service helicopters, cars, and motor vehicles, special task forces for special tasks.<sup>15</sup> Experts who have studied the role and importance of patrol-post service personnel in maintaining public order and security believe that this service is the heart of the police. Due to the principle of a decentralized police system in the United States, patrol-post service is organized differently in different states, depending on the specifics of the states. According to US law, the US National Guard, which is considered a reserve army, can also be involved in public order and security in the event of an emergency.<sup>16</sup>

The US National Guard obey to the governors of the States in peacetime, and during the war to the President of the US.

Japan also has a unique experience in maintaining public order and security. In the settlements of this state, this function is performed by the lower joints – the posts and stations of the police. Realizing that one of the main directions of improving the activities of the police is to strengthen of public cooperation, the Japanese government pays special attention to the activities of the police "booths" (Koban) in the living quarters of the population. In Japan, such a system was founded in 1874. In general, such posts and stations are considered the basis of the Japanese police, almost 40% of staff work in them.<sup>17</sup>

Police posts are located in the villages, where one employee (Chuzaisho) resides with his family and conducts service activities. Police stations, on the other hand, are located in cities and provide only a service building for an employee. At present, in such stations, from three to five police officers serve, and they keep the public order in control through a large number of telemonitors and means of communication.

These police stations operate in the framework of a single system and play a significant role in enforcing the rule of law throughout the country. To date, 6300 Kobans and 6600 Chuzaisho activities have been organized on the territory of the state. Police officers working in Koban not only maintain public order but also help the population in difficult situations.<sup>18</sup>

Research conducted in Japan indicates the flexibility of these stations to the specificity of their territories in which they are located. Patrol and post-service officers working at posts and stations conduct regular patrols in the assigned territories and work closely with each family, organization, institution.

According to Japanese legislation, an average of 400 families are attached to each police officer. During the service, officers conduct explanatory work among the population within the framework of the preventive measures, provide them with the necessary information and study the social opinion on the activities of the police. In addition, there are "contact stations with police" in Japan, these stations provide for the activities of voluntary associations of citizens. Currently, there are about 700,000 such stations, each covering about 50 families.<sup>19</sup>

In Japan, the police organize and conduct their service activities without political pressure. The National Commission for Social Security, established by the Cabinet of Ministers of Japan, will

<sup>12</sup> Klyuchevaya zadacha Rossiyskoy gvardii – bor'ba s terrorizmom i obespechenie obshestvennoy bezopasnosti rossiyskix grajdan [Elektronniy resurs] – Rejim dostupa: <https://rosghvard.ru>. – Data obrasheniya: 10.05.2020.

<sup>13</sup> Ziyadullaev M.Z. Zarubejnyy opit sistemi ohrani obshestvennogo poryadka i profilaktiki pravonarusheniy v naseleennykh punkтах // Jurnal zarubejnogo zakonodatel'stva i sravnitel'nogo pravovedeniya № 2, 2017.

<sup>14</sup> Shalyagin D.D. Polisiya SShA – organizatsionnie i pravovie osnovy deyatel'nosti. Avtoref. dis. kand. yurid. nauk. – M., 1998. – S. 17.

<sup>15</sup> Sherifi v Soedinennix Shtatax [Elektronniy resurs] – Rejim dostupa: <https://ru.qwe.wiki>. – Data obrasheniya: 13.05.2020.

<sup>16</sup> Public security in Federal polities [Elektronniy resurs] – Rejim dostupa: <https://books.google.co>. – Data obrasheniya: 13.05.2020

<sup>17</sup> Prestupnost' i kriminologiya v sovremennoy Yaponii / per. s yapon. O.A. Belyavskoy. – M.: 1989. – S. 154.

<sup>18</sup> Prestupnost' i kriminologiya v sovremennoy Yaponii / per. s yapon. O. A. Belyavskoy. M., 1989. S. 154

<sup>19</sup> Polisiya gosudarstv mira [Elektronniy resurs] – Rejim dostupa: <https://eurasialaw.ru>. – Data obrasheniya: 10.05.2020.





ensure the inviolability of the police system, protect the system from political pressure and maintain democratic methods of police management.<sup>20</sup>

The People's Republic of China (hereinafter referred to as the PRC), the world's leading country in terms of great number of population, also has extensive experience in ensuring public safety. The people's police of the PRC carry out most of these tasks. The People's Police of the PRC, in turn, is further subdivided into several types, and the public security police constitute one of these types. In order to ensure the safety and peace of the population, the public security police organize the round-the-clock service of the police officers, as well as the patrol officer service in the territories.

In order to perform these tasks, the police use the following methods of service:

a) *Duty service at permanent posts.* Duty service at permanent posts (*guān chá shào*) to ensure immediate movement in any situation. Besides observation in the posts, work is carried out to receive applications for crimes and irregularities from the local population, to assist the needy population.

b) *Patrol service.* In the conditions, if there is not the permanent post, the police officers carry out patrols in their territory, on foot, bicycles, cars, and motor vehicles.

c) *Visiting service.* Police officers, who are involved in the service in permanent posts, carry out regular visits to the places of residence and work of citizens living in the territory. During the visits, they provide citizens with suggestions on the prevention of crime and hear complaints from the people and suggestions on improving the quality of police service. They also register the population in their area.

In Shanghai and other major cities of the PRC, telephone communication between the police and the population has been established, and citizens can file complaints within 24 hours. Since 2005, more than 1,200 criminal cases have been revealed and about 5,000 people have been prosecuted.<sup>21</sup>

g) *Consulting services.* There are about 30,000 consulting services across China, each service consists of representatives of different social groups. Representatives of the group express their views and, together with the police, study and discuss the existing problems in ensuring public safety. In addition, contact groups are formed in order to prevent crime. The main task of contact

groups is to prevent crimes and create a healthy environment among minors. When the situation changes, the citizens belonging to the contact group, together with the police officers, carry out patrols and are involved in the implementation of propaganda work. The new Criminal Code adopted in 2006 is another important factor in ensuring a high level of public safety in the PRC. Experts believe that in many countries, some social acts that are considered disorderly are considered a crime according to the Criminal Code of the PRC. The death penalty is assigned for some types of crimes in PRC.<sup>22</sup>

## CONCLUSION

Analyzing the experience of developed countries such as the Russian Federation, the United States, Japan and the People's Republic of China in ensuring public safety, we can conclude that:

**firstly**, the organization of round-the-clock service in every region of the country, including distant villages, can be the basis for the effective maintenance of public order;

**secondly**, in the issue of prevention of crime and law enforcement, it will be effective to set close contact with the local population, to visit their place of residence and work, to make appropriate recommendations and listen to their suggestions;

**thirdly**, strengthening the normative-legal framework of the state, adherence to the principle of inevitability of punishment for the committed misdemeanor, and increasing the legal literacy of the population is one of the important factors;

**forth**, in some cases, to allow those officials to make independent decisions in the cases of prevention and elimination of violations (in the questions of the involvement of forces and means in this series) ensure speed and timeliness in management.

Having studied the foreign system of ensuring public safety, I propose to take into account the following measures in the organization of the activities of the National Guard Of The Republic of Uzbekistan:

## SUGGESTIONS

1. to develop measures to ensure close cooperation with self-governing bodies and the local population in the organization of activities to maintain public order and ensure the safety of the population in the living quarters, in the questions provision information, profiling of violations of the law and prevention of crime;

<sup>20</sup> National public safety commission [Elektronniy resurs] – Rejim dostupa: [https:// ru.qwe.wiki](https://ru.qwe.wiki). – Data obrasheniya: 14.05.2020.

<sup>21</sup> Osobnosti taktiki deyatel'nosti Narodnoy politsii Kitayskoy Narodnoy Respubliki pri nesenie sluzbi [Elektronniy resurs] – Rejim dostupa: [https:// cyberleninka.ru](https://cyberleninka.ru). – Data obrasheniya: 11.05.2020.

<sup>22</sup> Oficial'niy sayt Ministerstva obshestvennoy bezopasnosti KNR. [Elektronniy resurs] – Rejim dostupa: <http://www.mps.gov.cn>. – Data obrasheniya: 10.05.2020.





2. organization of visits of officers (employees) of the National Guard on duty to the homes (workplaces) of the population in the assigned territories and reporting at the end of the service (if necessary immediately) on the received appeals and proposals;
3. establishing of "National Guard Posts" in Mahallas where the criminogenic situation is unstable, until the situation stabilizes under the "Prosperous and Safe Mahalla" program.

## REFERENCES


1. Vasil'ev D. V. «Konsepsiya organizatsii deyatel'nosti politsii i vozmozhnosti ix ispol'zovaniya v otechestvennoy praktike: po materialam SShA i nekotorykh stran Zapadnoy Yevrope. Avtoreferat diss.kand.yurid. nauk. – M., 2005
2. Sharixin A.E. «Obshestvennaya bezopasnost' kak strategicheskii prioritet natsional'noy bezopasnosti Rossii: vikor puti» [Elektronniy resurs] – Rejim dostupa: <https://cyberleninka.ru>. – Data obrasheniya: 08.05.2020.
3. Ziyadullaev M.Z. «Zarubejniy opit sistemi oxrani obshestvennogo poryadka i profilaktiki pravonarusheniy v naseleennykh punktax» Jurnal zarubejnogo zakonodatel'stva i sravnitel'nogo pravovedeniya № 2. 2017 g.
4. Buxarov D.Z. «Jinoyatchilikning oldini olishda jamoatchilik ishtiroki: jahon tajribasi» Milliy qadriyatlar va shaxs ijtimoiy himoyasining huquqiy mexanizmlarini takomillashtirish: Respublika ilmiy-amaliy konferensiyasi materiallari. Toshkent, 2007 y.
5. Obzor rezul'tatov oprosa obshestvennogo mneniya o deyatel'nosti politsii (2019 god) [Elektronniy resurs] – Rejim dostupa: <https://mvd.rf.ru>. – Data obrasheniya: 08.05.2020.
6. Klyuchevaya zadacha Rossiyskoy gvardii – bor'bas terrorizmom i obespechenie obshestvennoy bezopasnosti rossiyskix grajdan [Elektronniy resurs] – Rejim dostupa: <https://rosgvard.ru>. – Data obrasheniya: 10.05.2020.
7. Federal'naya slujba voysk Natsional'noy gvardii Rossii. Voprosi uchastiya v oxrane obshestvennogo poryadka i obespechenie obshestvennoy bezopasnosti [Elektronniy resurs] – Rejim dostupa: <https://cyberleninka.ru>. – Data obrasheniya: 12.05.2020.
8. Sherifi v Soedinennykh Shtatax [Elektronniy resurs] – Rejim dostupa: <https://ru.qwe.wiki>. – Data obrasheniya: 13.05.2020.
9. Public security in Federal polities [Elektronniy resurs] – Rejim dostupa: <https://books.google.co>. – Data obrasheniya: 13.05.2020
10. Prestupnost' i kriminologiya v sovremennoy Yaponii / per. s yapon. O. A. Belyavskoy. M., 1989. S. 154.
11. Polisiya gosudarstv mira [Elektronniy resurs] – Rejim dostupa: <https://eurasilaw.ru>. – Data obrasheniya: 10.05.2020.
12. 12.Nationalpublicsafetycommission [Elektronniy resurs] – Rejim dostupa: <https://ru.qwe.wiki>. – Data obrasheniya: 14.05.2020.
13. Osobennosti taktiki deyatel'nosti Narodnoy politsii Kitayskoy Narodnoy Respubliki pri nesenie slujbi [Elektronniy resurs] – Rejim dostupa: <https://cyberleninka.ru>. – Data obrasheniya: 11.05.2020.
14. Oficial'niy sayt Ministerstva obshestvennoy bezopasnosti KNR. [Elektronniy resurs] – Rejim dostupa: <http://www.mps.gov.cn>. – Data obrasheniya: 10.05.2020.
15. Shalyagin D. D. Polisiya SShA – organizatsionnie i pravovye osnovy deyatel'nosti: avtoref. dis. . kand. jurid. nauk. M., 1998. S. 17.
16. Voronov A.M. Obshestvennaya bezopasnost': Administrativnie i informatsionno-pravovye problemi obespecheniya. Avtoreferat dokt. diss. jurid. nauk. M.:2005. – 56 s. <https://www.disscat.com/content/obshestvennaya-bezopasnost-administrativnye-i-informatsionno-pravovye-problemy-obespecheniya>
17. 17.Makarichev I.Yu. Administrativno-pravovoe obespechenie obshestvennoy bezopasnosti organami munitsipal'noy vlasti. Avtoreferat diss. kandidat jurid. nauk.–Lyuberskiy:2010.–32s.// <https://www.disscat.com/content/administrativno-pravovoe-obespechenie-obshchestvennoy-bezopasnosti-organami-munitsipalnoy-vl/read>
18. 18.Bikov, Andrey Viktorovich Organizatsionno-pravovye osnovy deyatel'nosti jandarmerii zapadnoevropeyskix gosudarstv v obespechenii obshestvennoy bezopasnosti tema dissertatsii i avtoreferata po VAK RF 12.00.02, kandidat juridicheskix nauk Moskva 1998 g 177 s.



## ORGANIZATIONAL AND ENVIRONMENTAL CHANGES: A BASIS FOR CURRICULUM REDESIGN

Charl Vince L. Porlares\*<sup>1</sup>, Emily B. Tan, PhD<sup>2</sup>

<sup>1</sup>MAED Student, University of Santo Tomas, Graduate School, Manila, Philippines,  
Junior Teacher, University of Santo Tomas, Senior High School, Manila, Philippines  
España Blvd, Sampaloc, Manila, 1008 Metro Manila,

ORCID:  <https://orcid.org/0000-0002-6877-1536> (Corresponding Author)\*

<sup>2</sup>Professor, University of Santo Tomas, Graduate School, Manila, Philippines  
España Blvd, Sampaloc, Manila, 1008 Metro Manila

Article DOI: <https://doi.org/10.36713/epra7241>

DOI No: 10.36713/epra7241

### ABSTRACT

*The education sector during the current pandemic has been greatly affected by the learning environment, management and administrative practices, and pedagogical aspects. Many schools around the world have made adjustments in their respective curricula to focus on what is essential during these trying times. The concept of school curriculum has been challenged to become more responsive to this large-scale universal undertaking. This paper explores curriculum development through the lens of the stimuli-response loop to show its dynamism. Furthermore, the researcher cites important cyclical models to picture how a curriculum develops and changes and integrates innovations during an organizational change. Finally, the researcher stitches the concepts of curriculum and organizational change through systems archetype in an attempt to suggest a model that would cater to such large-scale environmental movements like the current pandemic.*

**KEYWORDS:** *Environmental Challenges, Responsive Curriculum, School Curriculum, School Organization, Systems Archetype*

### INTRODUCTION

The Covid-19 pandemic has brought devastating effects in many fields and aspects of life. Such effects cascaded and have ultimately penetrated our everyday lives, termed as the “New Normal”. These effects have questioned many existing efforts toward modern-day development and challenged the pre-existing views of life. It is universally known that education characterizes what a society would look like, hence, we must take into account the processes and systems involved, as well as the related societal aspects in education and the environmental changes during the pandemic that have partially sealed off the educational sector either directly or indirectly.

The situation necessitates a change in education. This has been observed throughout the world and has ultimately impacted the environmental and

organizational aspects of schools. Governments and policymakers have ordered strict protocols including school temporary closure and astringent home quarantines (Petretto, Masala & Masala, 2020). This is in turn characteristically changed the dynamics of school activities, the most pronounced one is the shift from face-to-face instruction to online classes (Li & Lalani, 2020).

Glaringly, such a dramatic shift involved every element of schools: what, who, when, where, why, and how. In other words, the viewed changes comprise and challenge the goals of the school, stakeholders, teaching-learning environment, curriculum, pedagogy, assessment, and evaluation (Zhao & Watterston, 2021). Conjointly, highlighting the very soul of schools, the curriculum has also been changed (Pock et al., 2021; Gul & Khilji, 2021). This has brought an important



inquiry to the researchers: how have schools replanned and redesigned the school curriculum in the New Normal? Although there exist several models for curriculum development (Adirika & Okolie, 2017), it seems that a model that represents curriculum replanning, redesigning, and re-development involving environmental challenges and organizational change is still not evident. This paper connects the curriculum development process, organizational change, and environmental challenges by drafting a redesign and replanning model that may aid schools in adapting curriculum change during unpredictable times of crisis.

## LITERATURE REVIEWS

### The Dynamism of Curriculum: The Needs for Curricular Changes

Khan et al. (2019) stated that curriculum evolves. Gibs (2018) likened this curriculum development to a metamorphic stage of a butterfly—a chrysalis. It was mentioned in the paper that curriculum development was a slow and arduous change, often reflected in the barriers and challenges that education faces (Pak et al., 2020; Trudi, 2017). However, Gibs (2018) argued that even if the change is slow, progress is still present.

Using this as an impetus, the curriculum can be said to be alive (Khan et al., 2019; Alsubaie, 2016), existing and behaving like an organism. In biology, organisms have certain characteristics. One of which is sensitivity; being able to respond to a stimulus and act on it to produce valid changes that cater to its living cells (the stakeholders) for the most viable homeostatic range (organizational stability). Furthermore, microscopically, the trillions of cells forming specialized tissues and organ systems (units and departments of the organization), are also the ones producing minimal changes, but when massed together, create a visible transformation for the whole organism.

The dynamism of curriculum accounts for its environment and how the units of organization work interdependently to provide a characterized response to these changes. The role of school stakeholders and the school itself is needed to address changes in the curriculum. Supe (2016) stated the importance of proper management of curriculum change, innovation, and networking. Alsubaie (2016) concluded that school plays an important role in the adaptation, change, and development of curriculum through continuous development. Khan et al. (2019) stated that schools must provide a checklist to observe attainment of school quality standards. This checklist comes in the form of mission, vision, goals, objectives, and school philosophy; the variety of educational programs; and governance and administrative activities. It highlights

the role of schools in honing and designing the curriculum.

The environment is one of the stimuli for the school curriculum to move toward and gear for changes. Large-scale stimuli and changes are observed in line with this. Supe (2016) mentioned that technological innovations have brought changes to the curriculum. Schwab (2016) viewed these technological innovations as a challenge and opportunity and these need to be enacted along with policies. The technological revolution has overtaken the decade with the precedence of cybernetics, computers, and the internet. It caused an obvious integration of technology and curriculum as well as teaching-learning engagement through incorporating equipment and devices for educational purposes (Abdullah, 2016).

OECD (2018) accounted for the impacts of environmental and natural challenges and depletion of natural resources on education. Environmental challenges include earthquakes, volcanic eruptions, typhoons or tropical storms, drought, and related meteorological and climatic changes (Ireland, 2016). Ireland (2016) described the devastating effects of such disasters on different countries. For example, it was revealed in the report that, due to many disasters hitting Indonesia, the Philippines, and Vanuatu, education is severely disrupted. These archipelagic countries situated in the Pacific Ocean always face typhoons and typhoon-related disasters such as flooding and landslides. Schools were used as evacuation centers to cater to the survivors and schools were closed from 7-30 days (based on the ranges provided in the report).

Aside from technological and meteorological movements in the environment, several papers revealed how war, tension, and armed conflicts may affect education (Carr & Mallam, 1943; Diwakar, 2015; Hoenig, 2018). Carr & Mallam (1943) cited the works of Davis in 1942 and stated that wartime changed the temporal flow of activities in participant schools. New courses and research projects were also introduced. Diwakar (2015) verbalized how war has become a normalized phenomenon affecting Iraqi education. Violence caused death and fear, affected the implementation of the curriculum, an actual decline in the enrolment status, and the number of schooling years (Diwakar, 2015). A shift of mentality occurred causing the students' families and teachers to prioritize survival and forget about quality learning. Diwakar (2015) stated that as a supportive curriculum, the decrease in supply factor has also added to the decline in learning. This is due to the reduction of budget, shortage of electricity, and depreciated learning materials.

This roughly gives a view of how the time, spatial, supportive, hidden, and procedural structure of the curriculum is discontinued and it presents an



unclear picture of how the curriculum can help the learning of the remaining students. This also raises the question of how the curriculum is continued despite an obvious pause. Taking into consideration the well-being of the school stakeholders and the extended issues after the disaster, are there any salient improvements, redirection, and replanning of the curriculum to cater to such changes? Ireland (2016) mentioned in her report that there were existing safety frameworks, protocols, and guidelines, however, it seems that a direct representation of curricular replanning is still unclear to alter the curriculum to suit such conditions or situations.

Moreover, this inquiry is strengthened because of the current pandemic: when and where there's a large disruption of the normal academic activities, how is the curriculum replanned? How does the replanning and redesigning take into consideration the respondents of stimuli (school as organization) and the stimuli (changes in the environment) at such a large scale?

Charland et al. (2021) explored in their recent paper how pandemic intricately affects the education sector through the lens of the school curriculum. They discussed how the four dimensions of the curriculum are affected: teachers are affected by lack of training for transitioning and the professional and familial responsibilities; students' achievement may decline and

they are tremendously affected in both physical and psychological health; subject matter expectations are reduced and accelerated, establishing key learning priorities as essential and desirable, giving much focus on the former; the milieu is affected by the different strict safety measures and health protocols; parents are also taken into account, their new cooperative roles are needed despite having been poorly equipped.

With such a scale of effect, how does the curriculum respond and act to such fast-changing and unpredictable chaotic situations (Charland et al., 2021)?

## MODELS OF CURRICULUM DEVELOPMENT

To further understand the claims of the researchers, selected models representing curriculum developments are presented. The curriculum is a dynamic systematic process involving different people, strategies, procedures, and even tools for development.

This can be viewed as the stimulus-response feedback loop, hence, the two models present a cyclical but continuous nature because a process must not be bypassed otherwise it will cause instability. Newlyn & Blissenden (2011) and Mai (2015) described Print's (1989) continuum of curriculum development model where the cyclical model of Wheeler and Nicholls & Nicholls was explained.

### *Wheeler's Cyclical Model of Curriculum Development*

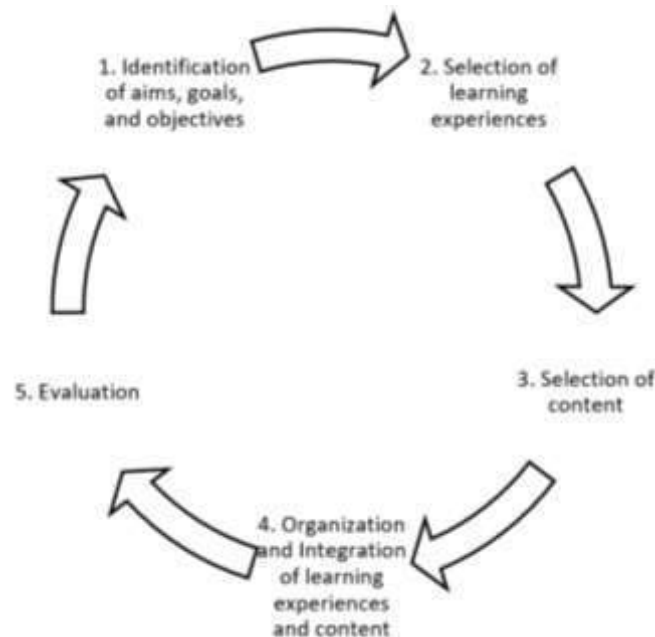


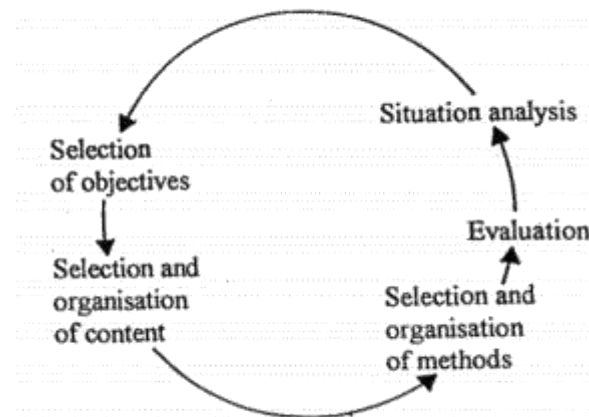
Figure 1. Wheeler's Curriculum Model (Drawn after the image from Adirika & Okolie, 2017)



Bhuttah et al. (2019) mentioned that this model best illustrates the flexibility and continuity of curriculum development. The cyclical nature of the model stresses continuous improvement and its dynamism accounts for adoption and adaptation (Adirika & Okolie, 2017; Bhuttah et al., 2019). Continuing with the metaphorical vein, adaptation is a characteristic of a functional organism placed in its environment. This gives a picture of how an organism becomes interdependent and interrelated with its surrounding. Adirika & Okolie (2017) and Bhuttah et al. (2017) described the relationship between the variables in the Wheeler's Model in the same fashion; the degree of interaction is necessary to keep the cycle going.

The approach itself is deductive. It starts with writing the proper objectives and goals that become the key driver in establishing the cycle. The process is followed by selecting learning experiences then selecting learning content. Mai (2015) mentioned that Wheeler clarified the distinction between the learning experience and content, which amended the work of Tyler, the Four Basic Principles of Curriculum Rationale (Bhuttah et al., 2019). These steps are followed by organizing the learning experience and content. Lastly, evaluation takes into account identifying the strengths and weaknesses of each stage to attain the aims and objectives (Adirika & Okolie, 2017).

### *Nicholls & Nicholls' Cyclical Model of Curriculum Development*



**Figure 2. Nicholls and Nicholls' Curriculum Model (from the work of Print, 1989, cited in Tiede, 1995).**

Adirika & Okolie (2017) mentioned that this model is guided by the external environment such as the locality where the school is found, hence, objectives formed and developed must picture the local environment where the students belong. This allows a more responsive education that caters to its immediate surroundings. This is best understood as contextualized where the roles for the local and national development are taken into account to view education in a real-life situation.

The model has five phases (Fig. 2) similar to Wheeler's, beginning with the situational analysis (Adirika & Okolie, 2017). This is followed by the selection of learning objectives, which stem from pre-

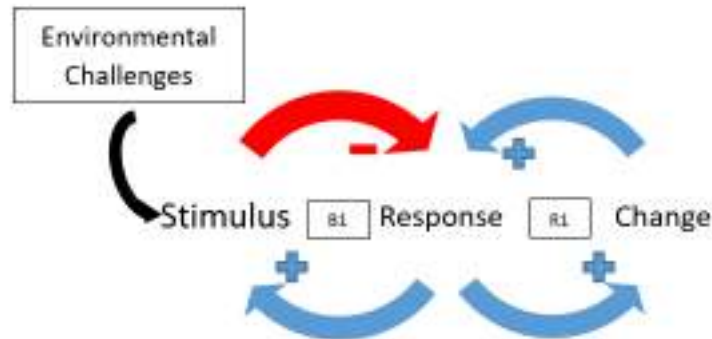
existing data and information brought about by the initial step. Next is the selection and organization of content, followed by the selection and organization of methods. These steps are inherently different from the stages in Wheeler's Model as selection and organization occur simultaneously and methods are emphasized instead of the learning experience. The last stage is the evaluation (Adirika & Okolie, 2017).

Both models eye the importance of having sound aims and goals, as such, the two models have a prescriptive view of education through learning outcomes and objectives. Further, both underscore the importance of evaluation as a form of feedback for the cycle.





### Environmental Changes for Curriculum Redesign: Situational Analysis



**Figure 3. Analyzing Stimulus-Response Feedback Loop and Environmental Challenges**

As metaphorized, the researchers view curriculum as living dynamics. *Figure 3* shows how the researchers characterize the dynamism of Curriculum Redesign: environmental challenges act as the stimuli in the causal loop, and these bring unwanted and unknown deviances to the homeostatic nature of schools. Such is the case of the current pandemic, the permeation of its effects has not only caused interference with the face-to-face learning and administrative and managerial functions but also to the curricular aspects of the schools. A variety of curricular support forming the learning spaces such as libraries, scientific laboratories, Physical Education gymnasium, and classrooms (support curriculum) have left unused and stagnant, and the intended curriculum (lesson plans, syllabus, and course outcomes) altered, the social system and school culture (hidden curriculum) unexperienced by the students, and others.

The large-scale environmental/external challenges may bring negative continuous stimulation to the system that needs to be responded to immediately, for positive changed to take place. These curricular changes consider the response is reflected as positive feedback to the response, which deals with the stimulus. The loop showcases both a balancing structure (stimulus-response) and a reinforcing loop (response-change). This loop explores the causal relationship between the variables and, for this particular representation, begins with analyzing the situation and the environment. It emphasizes the first part of Nicholls & Nicholls' Cyclical Model.

Detailing the changes in the environment needs to be carefully addressed as it allows the foundation of the curriculum development process. This detailing is seen as the identification of the needs and how they can be used for crafting the curriculum. As the brain of every curriculum development process, the school has the

power and responsibility to identify the needs and the situation of the curriculum. In doing so, the situational analysis may be applied (Schneiderhan, Guetterman & Dobson, 2019; Todea & Demarsek, 2017); Todea & Demarcsek (2017) alternately used the need analysis and target situation analysis. Bachri (2018) referred to this as requirement analysis. He wrote that needs analysis targets to profile the needs of the learners, community, and subject field. Hence, situational analysis allows curriculum responders and leaders to factor in potential impacts, both negative and positive risks, into planning and designing the curriculum. Curriculum responders, in this case, are people, who may affect and may be affected by the curriculum, aside from the leaders.

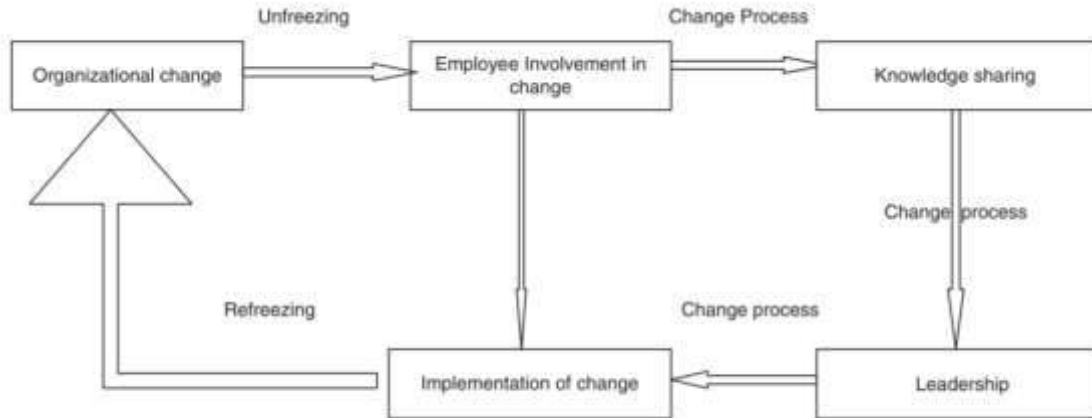
Todea and Demarcsek (2017) explicated that requirement analysis is not a one-time approach but a continuous repeated process. In this representation, the large-scale environmental and external challenges may unknowingly produce an unwanted and unwarranted shift. This characterizes its unpredictability, complexity, and ambiguity, hence, it may produce continuous stimuli and long-lasting changes.

The utilization of requirement analysis acts as a springboard by providing information about this shift and is helpful in the curriculum development process (Todea & Demarcsek, 2017). Information may be drawn out from structured, semi-structured, & research techniques and policies (Schneiderhan, Guetterman & Dobson, 2019). Schneiderhan, Guetterman & Dobson (2019) mentioned the importance of composing a rationale statement to strengthen the foundation for the development.

In the case of this paper, needs analysis does not essentially cater to each student's needs but the general whole and the ongoing situation because, as mentioned, large-scale challenges are the stimuli for the change.



## Organizational Changes for Curriculum Redesign: Lewin's 3-Step Change



**Figure 4. Lewin's 3 Step Change Model (from the work of Hussain et al., 2018)**

The metaphorized loop (Fig. 3) shows that after the response is the directed change. Change is a necessary step in the loop because it is the one that brings adaptations leading to homeostasis. Deborah (2018) mentioned the postulate of Lewin about change, "motivation for change must be generated before change can occur" (p. 3). The researchers apply Lewin's Change Model which explicates important key change stages that an organization undergoes. These phases are vital neural steps in this organismic view of curriculum change, for it is the organization that acts as the brain to produce change.

Hussain et al. (2018) noted that change is a difficult process and this is especially true for an organization with longstanding culture. Burnes (2004) metaphorized the progression of Lewin's change as an ice cube that needs to be liquefied to respond to change by actively shaping it and solidifying the desired shape (cited in Deborah, 2018). This is how the status quo is temporarily disturbed to gain balance and anchorage again to achieve the desired state (Hussain et al., 2018). *Figure 4* establishes that the motivated organizational change begins with the unfreezing stage. Hussain et al. (2018) mentioned that change is stimulated externally and internally hence change must be planned as a "proactive change" rather than a pressured change to seek the active involvement of the stakeholders for a desirable change. Deborah (2018) stated that this enhances the driving force for stakeholders to shift toward change and it needs communication. Deborah (2018) also mentioned that unfreezing stage is the hardest and most stressful phase because not everyone wishes to participate in change.

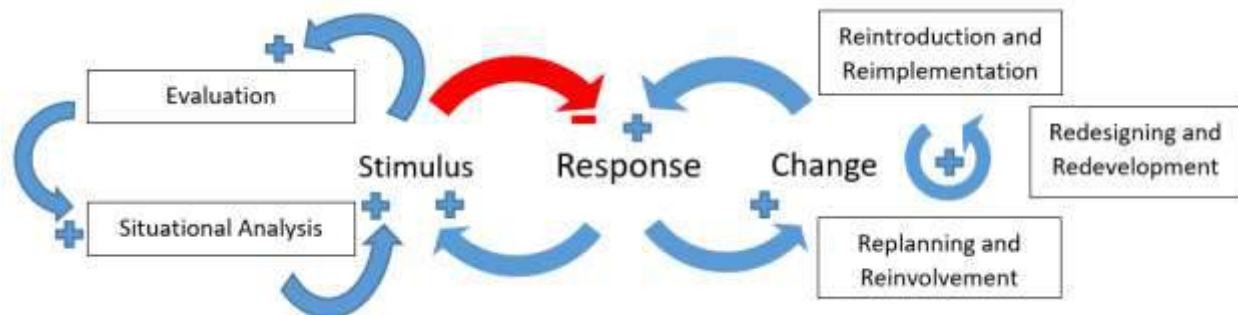
Next is the actual change stage that involves new data and new reactions (Pawar & Charak, 2017). Hussain et al. (2018) determined the importance of generating new knowledge through the collective effort of the involved stakeholders and this new information have to be shared as a form of "organizational learning" (p.125). Wenger (1999) mentioned that the generation of new knowledge is done either by inviting a third-party or agency intervention or by inviting experts within the organization (cited in Hussain et al., 2018).

Moreover, the generation of new knowledge is managed by leaders, hence leadership is a key factor shown in *Figure 4*. Pawar & Charak (2017) mentioned that support at this stage is critical because change is complicated due to the gradual transition. This support is given by the leaders as "hands-on management" (Deborah, 2018, p.5) through and with preparation, training, and expectations (Pawar & Charak, 2017). Hussain et al. (2018) mentioned leadership defines the kind of stakeholders who will support the change.

The final stage is the actual implementation of change, the refreezing. Pawar & Chakar (2017) stated that this is when the security of the organization is built up again and the new changes become the new standard. Hussain et al. (2018) discussed that the shift is simultaneous and requires activities to support the change. This gives an assumption that the stakeholders need to carefully adapt, include and clarify new processes and integrate them as routine, hence, there's a degree of discontinuity of previous practices. Anchorage and the establishment of the new changes are very critical at this stage. Deborah (2018) wrote that if this phase is improperly done, change will become short-lived, and the previous status quo will reemerge.



### A Proposed Model for Replanning and Redesigning a Responsive Curriculum



**Figure 5. Diagram for Responsive Curriculum Replanning and Redesign**

The model (Fig. 5) depicts the relationship between stimulus, response, and change. This representation relies on the environmental challenges and organizational movement to target risks, threats, and uncertainties, hence, it targets complex learning situations such as education during war, technological revolutions, calamities, and even the pandemic.

To understand the model in the essence of curriculum development, the researchers lay down these premises:

1. Curriculum change must be a planned change.
2. School as an organization is the brain for the change.
3. Environmental needs and challenges are stimulants for curricular change.
4. Curriculum change is a response to the needs and challenges of a school.
5. School stakeholders are the curriculum responders.
6. Evaluation is vital for continuity.

The researchers argue that schools are stimulated by both internal and external challenges, however, cases like the current pandemic, demand a drastic curriculum behavioral change to counter it. As such, the change involves almost all the stakeholders and curriculum change at this level is a form of organizational change. Arising issues and problems identified through the situational/needs analysis will add to the prior stimuli creating an overlap. In this stage, the identification of key strengths, weaknesses, opportunities, and threats is vital. Following this is the response stage, where the initially identified issues are processed, what areas of the curriculum do the issues target? How is it affected? What are the implications? Is the organization ready to take on such challenges? Is the school ready for a planned curriculum change? This phase is the readying stage of the organization and is the springboard for future change.

Following the cyclical steps of curriculum development, the researchers integrate Lewin's 3 Steps Change. The model surmises the initial stage (unfreeze phase) as the replanning and reinvolverment stage where the data collected from the needs analysis and response processing are utilized to draft and replan a curriculum. Curriculum leaders and curriculum responders are called forth to drive the change. This is followed by the redesigning and redevelopment stage (change phase) where the past curriculum will be readjusted and patterned based on the needs analysis. Efforts of curriculum leaders are expected because they will become the link for the stakeholders. Their expertise, experience, and wisdom are needed for curriculum structuring. The flow of communication should be observed, people empowerment is emphasized, and knowledge management is needed.

Lastly, the phase of reintroduction and reimplementation called the refreezing stage entails the consolidation of the readjusted and redesigned curriculum and sharing of information to the curriculum responders. This level observes an active phase of reinforcing the desired curricular change and slowly integrating the change at the classroom level whether virtual or actual. The curriculum change is feedbacked as a response to the stimuli, where there is an organizational practice of the change and continuous adjustment. Finally, to solidify the change and continuously improve, evaluation is implemented.

### CONCLUSION AND FUTURE DIRECTIONS

This paper attempted to conceptualize a new model for responsive curriculum development. Through the lens of biological dynamism and organizational change, the study established the link between curriculum development and large-scale challenges. The emergence of the pandemic is an



example of the large-scale challenges that caused a drastic curriculum readjustment. This model also shows a systemic and systematic way of redesigning the curriculum.

Educational leaders are enjoined to try developing a responsive curriculum by applying this model. Future researches using qualitative research designs may be undertaken to find out the effectiveness and efficiency of the proposed model.

## REFERENCES

1. Abdullah, F. (2016). *Integrate Technology In The Curriculum As An Effective Teaching Strategy*. *International Journal of Academic Research*, 4(1), 40-50. [https://www.researchgate.net/publication/336115867\\_Integrate\\_Technology\\_In\\_The\\_Curriculum\\_As\\_An\\_Effective\\_Teaching\\_Strategy](https://www.researchgate.net/publication/336115867_Integrate_Technology_In_The_Curriculum_As_An_Effective_Teaching_Strategy)
2. Adirika, B. N. & Okolie, V. C. (2017). *Examining Models Of Curriculum Development And Processes: Implications For African Educational Heritage And Review*. *Social Science and Humanities Journal*, 6, 325-342. <http://sshj.in/index.php/sshj/article/view/44>
3. Alsubaie, M. A. (2016). *Curriculum Development: Teacher Involvement in Curriculum Development*. *Journal of Education and Practice*, 7(9), 106-107. <https://files.eric.ed.gov/fulltext/EJ1095725.pdf>
4. Bachri, B. S. (2018). *Curriculum Development and Implementation on Higher Education in Indonesia*. *Advances in Social Science, Education and Humanities Research*, 212, 496-498. <https://doi.org/10.2991/icei-18.2018.106>
5. Bhuttah, T. M., Xiaoduan, C., Ullah, H. & Javed, S. (2019). *Analysis of Curriculum Development Stages from the Perspective of Tyler, Taba and Wheeler*. *European Journal of Social Sciences* 58(1), 14-22. [https://www.europeanjournalofsocialsciences.com/issues/PDF/EJSS\\_58\\_1\\_02.pdf](https://www.europeanjournalofsocialsciences.com/issues/PDF/EJSS_58_1_02.pdf)
6. Carr, W. G., & Mallam, M. L. (1943). *Effects of the World War on American Education*. *Review of Educational Research*, 13(1), 13. <https://doi.org/10.2307/1168806>
7. Charland, P., Martineau, M. D., Gadais, T., Arvisais, O., Turgeon, N., Vinuesa, V., & Cyr, S. (2021). *Curriculum response to the crisis*. *Prospects*. <https://doi.org/10.1007/s11125-020-09526-6>
8. Deborah, O. K. (2018). *Lewin's Theory of Change: Applicability of its Principles in a Contemporary Organization*. *Journal of Strategic Management*, 2(5), 1-11. <https://stratfordjournals.org/journals/index.php/journal-of-strategic-management/article/view/229/274>
9. Diwakar, V. (2015). *The Effect of Armed Conflict on Education: Evidence from Iraq*. *The Journal of Development Studies*, 51(12), 1702-1718. <http://dx.doi.org/10.1080/00220388.2015.1056786>
10. Gibbs, T. (2018). *Curriculum development: A dynamic change inside the chrysalis*. *Medical Teacher*, 40(5), 434-436. <https://doi.org/10.1080/0142159X.2018.1457286>
11. Gul, R., & Khilji, G. (2021). *Exploring the need for a responsive school curriculum to cope with the Covid-19 pandemic in Pakistan*. *Prospects*, 1-20. <https://doi.org/10.1007/s11125-020-09540-8>
12. Hoenig, T (2018). *The Effect of Conflict on Education: Evidence from Sierra Leone*. *Munich Personal RePEc Archive*, Paper No. 85064, 1-23. <https://mpra.ub.uni-muenchen.de/85064/>
13. Hussain, S. T., Lei, S., Akram, T., Haider, M. J., Hussain, S. H., & Ali, M. (2018). *Kurt Lewin's change model: A critical review of the role of leadership and employee involvement in organizational change*. *Journal of Innovation & Knowledge*, 3(3), 123-127. <http://dx.doi.org/10.1016/j.jik.2016.07.002>
14. Ireland, S. (2016). *Save the Children – Education Disrupted: Disaster impacts on education in the Asia Pacific region in 2015*. *ReliefWeb*. [https://reliefweb.int/sites/reliefweb.int/files/resources/education\\_disrupted\\_save\\_the\\_children\\_full\\_report.pdf](https://reliefweb.int/sites/reliefweb.int/files/resources/education_disrupted_save_the_children_full_report.pdf)
15. Khan, R. A., Spruijt, A., Mahboob, U., & van Merriënboer, J. J. G. (2019). *Determining "curriculum viability" through standards and inhibitors of curriculum quality: a scoping review*. *BMC Medical Education*, 19(1), 1-11. <https://doi.org/10.1186/s12909-019-1759-8>
16. Li, C. & Lalani, F. (29 April 2020). *The COVID-19 pandemic has changed education forever. This is how*. *World Economic Forum*. <https://www.weforum.org/agenda/2020/04/coronavirus-education-global-covid19-online-digital-learning/>
17. Newlyn, D. & Blissenden, M. (2011). *Tax Law Curriculum: Implications of Formal Curriculum Theory to Practice*. *Journal of the Australasian Law Teachers Association*, 147-155. <http://classic.austlii.edu.au/au/journals/JIALawTA/2011/14.html>
18. Mai, M. Y. (2015). *Developing Context-Based Science Curriculum: Humanizing Science Curriculum*. *Academic Journal of Interdisciplinary Studies*, 4(1), 171, 184. <https://doi.org/10.5901/mjss.2015.v4n1s1p171>
19. OECD (2018). *The Future of Education and Skills: Education 2030*. OECD. [https://www.oecd.org/education/2030/E2030%20Position%20Paper%20\(05.04.2018\).pdf](https://www.oecd.org/education/2030/E2030%20Position%20Paper%20(05.04.2018).pdf)
20. Pak, K., Polikoff, M. S., Desimone, L. M., & Saldívar García, E. (2020). *The Adaptive Challenges of Curriculum Implementation: Insights for Educational Leaders Driving Standards-Based Reform*. *AERA Open*, 6(2). <https://doi.org/10.1177/2332858420932828>
21. Pawar A. & Charak, K. (2017). *Study on Adaptability of Change Management: Review of*





- Kurt Lewins and Kotter Model of Change. International Journal of Social Science and Management, 5(4), 79-83. [https://www.researchgate.net/publication/339955706\\_Study\\_on\\_Adaptability\\_of\\_Change\\_Management\\_Review\\_of\\_Kurt\\_Lewins\\_and\\_Kotter\\_Model\\_of\\_Change](https://www.researchgate.net/publication/339955706_Study_on_Adaptability_of_Change_Management_Review_of_Kurt_Lewins_and_Kotter_Model_of_Change)*
22. Petretto, D. R., Masala, I., & Masala, C. (2020). School Closure and Children in the Outbreak of COVID-19. *Clinical practice and epidemiology in mental health: CP & EMH, 16*, 189-191. <https://doi.org/10.2174/1745017902016010189>
  23. Pock, A. R. Williams, P. M., Maranich, A. M., Landoll, R. R., Witkop, C. T., Reamy, B.V., & Durning, S. J. (2021). Curricular Change and Resiliency in the Era of Coronavirus (COVID-19): The Uniformed Services University of the Health Sciences (USU) Experience. *Military Medicine, 186(1-2)*, 212-218, <https://doi.org/10.1093/milmed/usaa491>
  24. Schneiderhan, J., Guetterman, T. C. & Dobson, M. L. (2019). Curriculum development: a how to primer. *Family Medicine and Community Health, 7*, 1-6. <https://doi.org/10.1136/fmch-2018-000046>
  25. Schwab, K. (14 January 2016). The Fourth Industrial Revolution. World Economic Forum. [https://law.unimelb.edu.au/\\_data/assets/pdf\\_file/0005/3385454/Schwab-The\\_Fourth\\_Industrial\\_Revolution\\_Klaus\\_S.pdf](https://law.unimelb.edu.au/_data/assets/pdf_file/0005/3385454/Schwab-The_Fourth_Industrial_Revolution_Klaus_S.pdf)
  26. Supe, A. (2016). Designing a dynamic contextual curriculum. *International Journal of Advanced Medical and Journal Research, 3(2)*, 55-57. [https://www.ijamhrjournal.org/temp/IntJAdvMedRes3255-8481205\\_233332.pdf](https://www.ijamhrjournal.org/temp/IntJAdvMedRes3255-8481205_233332.pdf)
  27. Tiede, L. (1995). *The Participant's Summative Perceptions of the Quality Function Deployment (QFD) Process as Used to Review a School Policy.* [https://ro.ecu.edu.au/theses\\_hons/662/](https://ro.ecu.edu.au/theses_hons/662/)
  28. Todea, L., & Demarcsek, R. (2017). Needs analysis for language course design. A case study for engineering and business students. *IOP Conference Series: Materials Science and Engineering, 200*, 012064. <https://doi.org/10.1088/1757-899x/200/1/012064>
  29. Trudi, C. (2017). Curriculum Renewal: Barriers to Successful Curriculum Change and Suggestions for Improvement. *Journal of Education and Training Studies, 5(11)*, 115-128. <https://files.eric.ed.gov/fulltext/EJ1161219.pdf>
  30. Zhao, Y., Watterston, J. (2021). The changes we need: Education post COVID-19. *Journal of Educational Change 22*, 3-12. <https://doi.org/10.1007/s10833-021-09417-3>





# SOCIO-ECONOMIC FACTORS BEHIND UN-SATISFACTORY PERFORMANCE OF ANGANWADI CENTERS UNDER ICDS PROGRAMME IN INDIA

Sudeshna Saha<sup>1</sup>, Dr. Bikash Saha<sup>2</sup>

<sup>1</sup>Research Scholar of department of Education, University of Burdwan, Dist.- Burdwan,  
West Bengal, India

<sup>2</sup>Associate Professor of Economics, Department of Economics, Bolpur College, Bolpur,  
Dist.-Birbhum, West Bengal, India

## ABSTRACT

*Integrated Child Development Services (ICDS), launched on 2nd October, 1975 in our country is the largest flagship program to address nutrition and development needs of children below six years and reduce burden of under nutrition. It also aims to improve nutrition status of pregnant and lactating women (PW & LW), thereby impacting on the nutritional outcomes among children and break intergenerational cycle of under nutrition. But after 4 decades from the implementation of the programme, we have not achieved our millennium goal. This study has tried to locket that particular socio-economic pockets for which the performance of the programme stumbles in its growth path. A set of cross-sectional data of 20 states in India has used here. For explanation, simple bi-variate linear regression model has used. The study finds that the lack of availability of infrastructural facility, creche facility, assistance from local institutions and low payment to AWWs are the main causes of low performance of AWCs.*

**KEY WORDS:** ICDS, Anganwadi Worker, Anganwadi Center, External Assistance, Health Education, Preprimary education, Nutritional support and Women's' group.

## INTRODUCTION

Despite making significant progress in the field of economic development, social development indices in the country have not been commensurate with improvement in economic development. Reduction of undernutrition among others has remained one of the biggest challenges before the nation embarking on a path of meeting MDG targets.

Even in this age of scientific advancements in technology and medicine, delivering quality health care to pregnant and lactating mothers and their children continues to be a far-fetched dream in India. Annually, around 50,000 mothers lose their lives due to pregnancy-related complications, while more than 1.5 million children die each year before reaching their first birthday. Institutional delivery entails giving birth in a medical institution, under the supervision and care of skilled medical professionals. Institutional delivery helps in the reduction of infant and maternal mortality and is also linked with the overall health status of the mother and the child. (RetherfordR.D., 2001)

In spite of the numerous efforts and programs launched by the Government of India (GoI) to promote institutional delivery, still one fourth of the rural women did not deliver in an institution (NFHS-4, 2015-16)

Apart from the low levels of institutional delivery, the levels of child undernutrition in India are a matter of grave concern. The rates of malnutrition among under-5 children in India are among the highest in the world and almost 5 times as compared with Sub-Saharan Africa. Around half of India's children are underweight, and 45% are stunted and 20% are wasted - (Bank, 2013)

Undernutrition puts the children at a greater risk of death due to common infection as it results in an increase in the severity of such infections and also delayed recovery. Lack of proper nutrition during the first 1,000 days of a child's life can result in stunted growth of the child, which is irreversible and associated with impaired cognitive ability and reduced school and work performance. Nearly half of all under-5 child mortality in India is attributable to



undernutrition (UNICEF, 2017). According to National Family Health Survey 4 (NFHS-4), the prevalence of stunting, wasting, and underweight among under-3 children in India is 38%, 21%, and 36%, respectively (NFHS-4, International Institute for Population Science, 2015-16)

Integrated Child Development Services (ICDS), launched on 2nd October, 1975 in our country is the largest flagship program to address nutrition and development needs of children below six years and reduce burden of under nutrition. It also aims to improve nutrition status of pregnant and lactating women (PW & LW), thereby impacting on the nutritional outcomes among children and break intergenerational cycle of under nutrition. (Welfare, 2012-13)

### LITERATURE SURVEY

Today, ICDS scheme represents one of the world's largest and unique programs for early childhood development to improve the condition of expectant and nursing mothers. ICDS symbolizes India's commitment to her children towards meeting the challenge of providing pre-school education and breaking the vicious cycle of malnutrition, morbidity, reduced learning capacity and mortality.<sup>10</sup> It attempts to provide a package of wholesome integrated service, supported by related services like mid-day meal, balwadi, and special nutrition. (Gupta J.P., 1979)

The Anganwadi worker (AWW) is the community based voluntary frontline worker of the ICDS programme. Selected from the community, she assumes a pivotal role due to her close and continuous contact with the beneficiaries. (Lal)

ICDS is a centrally sponsored scheme run by the State Govt. / UT through AWCs. The main object of the scheme – to improve nutritional and health status of children in the age group of 0-6 yrs, to lay foundation of proper psychological, physical and social development of children to reduce the incidence of mortality, morbidity, malnutrition and school dropout, to enhance the capability of the mother to look after the normal health and nutritional need of the child through proper nutrition and health education. The ICDS Programme provides an integrated package of health, nutrition and education services. The programme aims to cover economically or socially marginalized sections of women and children as primary beneficiaries.

The major objectives of the ICDS Scheme are : i) Improvement in nutritional and health status of the children in the age group of 0-6 years; ii) Laying the foundation for a proper psychological, physical and social development of the children; iii) Reduction in the incidence of mortality, morbidity, malnutrition and school dropouts; iv) Co-ordination of policy and implementation amongst various departments to promote child development; and v)

Enhancement of the capacity of the mother to look after the normal health and nutritional needs of the child through proper nutrition and health education.

There is a significant progress in the implementation of ICDS scheme during the years 2002 to 2012 in terms of increase in number of operational projects and AWCs & coverage of beneficiaries. (Annual Report, 2016-17)

But, the performance of the programme – barring in few states – has been more lackluster than indicative of a serious effort to eradicate the evils that are severely detrimental to the development of the Indian children. Even after three decades of the launching of the programme it could bring only a quarter of the children into its fold. And, hardly the quality of the services provided was up to any mark. While the design of the programme included a number of composite services. In many parts of the country, it was taken as the khichri programme, since it only provided a mixture of rice and pulses cooked together undermining the rest of the important services. In addition, despite being a centrally sponsored programme the performance of the programme has been widely varying from region to region. While some of the Indian provinces, particularly Tamilnadu, have made remarkable progresses in achieving the goal of universalising the programme with quality, many of the constituents of the republic seems to have performed dreadfully poorly. They neither seemed to follow the national commitment nor was there any evidence to learn from the performing states. (FOCUS, 2006)

ICDS is the premier malnutrition control program for more than four decades. Even though a large expenditure was made on the program, the results in terms of a change in incidence of malnutrition have not been forthcoming, more so in states like Bihar. Bihar exhibited an impressive economic growth but still languishes at bottom with malnutrition rate of 82% (Sciences, 2000 ) and (Science, 2007)

Existing literature shows that there are conflicting thoughts on the extent of its success. For example, in a study conducted by the World Bank, it was shown that “there is little evidence of ICDS program impact on overall child nutrition status” (Monica Dasgupta, 2005) and at times a *negative* impact. This is because in spite of wide coverage, there is lack of optimal utilization (Gupta A, 2013) and the quality of services needs to be improved to get the desired results (Chudasama, 2015) . A case study in Kashmir revealed that the medical check-up of children below 3 years of age was not up to the mark. Due to lack of proper coordination between the health and ICDS staff, none of the children below 3 years of age were immunized (Bashir, 2014).



### Facilities and performance of AWCs

The following table 1; shows performance index and different facilities provided to the AWC

and AWWs of 20 states in India, in order to support to maintain their regular project-related activities.

**Table 1; State wise information of ICDS about their performance and facilities available to them**

	1	2	3	4	5	6	7	8	9	10	11	12	13	14	15
Andhra Pradesh	0.689	41.6	33.6	18.5	28	1.2	9.3	48	16.8	92.7	6.4	1	39.8	67.1	29.8
Assam	0.253	44.5	74.3	50.2	82.7	2.2	0	56	4.6	87.1	10.7	0	69.6	66.6	43.9
Bihar	0.248	55.3	57.6	10.4	19.3	4.5	1.5	43.7	17.5	98.6	1.4	0	16.1	37.2	15.7
Chhattisgarh	0.53	54.1	28.9	93.3	57.5	0	27	18.2	13.4	89	4.8	0	92.6	77.6	49.9
Gujrat	0.563	39	19.5	36.8	56.2	0	9.5	30.9	17.6	77.7	17.4	4.9	61.5	54.5	46.2
Haryana	0.57	24.4	8	17	7.2	1.7	0	58.1	3.2	96.7	1.7	0.8	28	65.8	42.5
Himachal Pradesh	0.54	65.9	16.1	69.9	78.8	0	8.7	62.7	0	69.9	30.1	0	10.1	77.4	97.4
Jambu & Kashmir	0.494	19	33.8	39.6	42.8	0	0.5	37.3	0.8	90.6	5.1	3.3	1.3	18.4	65.3
Jharkhand	0.68	4	11	45.4	53.4	0	0	50.1	9.5	87.8	10.4	1.8	43.4	62.8	31.2
Karnataka	0.728	58.2	52.8	59.4	43.7	1.3	6.4	50.7	5.9	96.8	3.2	0	65.3	55.3	34.9
Kerala	0.612	87.6	49.5	84.1	94	3.1	1.6	43.9	6.2	72.8	25.8	1.4	65	78.9	77.1
Madhya Pradesh	0.572	35.9	30.3	48.1	46	1.2	3.3	33.7	14.8	96.4	1.5	1.6	48.9	88.1	43.9
Maharashtra	0.716	49.3	43.9	60.3	56.6	0	7.6	50.8	10.2	88.9	7.2	2	68.5	57.9	58.4
Orissa	0.635	28.7	42.5	58.6	61	0	1	36.6	35.1	79.8	15.3	3.1	53.5	59	19.6
Punjab	0.402	61.4	8.4	6.1	10.1	7	0	38.4	19.2	85	8.9	3.4	11.6	57.1	40.9
Rajasthan	0.317	17.6	15	35.3	35	0	19.2	17.1	1.2	84.9	6.2	3.4	39.6	48.6	28.6
Tamilnadu	0.671	34.9	29.6	29.9	32.5	3.7	0	65.1	10.8	43.9	29.2	13.9	85.6	70.9	79
Uttar Pradesh	0.295	29.7	6.2	15.7	39.8	4.3	0	28.1	32.1	80.3	17.5	1	6.7	75.5	16.9
Uttaranchal	0.372	9.7	3.9	0	0	0	0	11.7	66	68.8	31.2	0	35.2	61.7	55.6
West Bengal	0.682	40.8	28.8	26.5	82	0	0	52.5	5.4	52.9	23.1	17.1	34.5	74	28.5

Source: Evaluation Study on Integrated Child Development Schemes (ICDS), Volume-1, Programme Evaluation Organization, Government of India, New Delhi, March 2011. Compiled by researcher.

### Clarification of the data (column wise)

- 1) Overall performance index which includes; a) average number of days received food, b) Percentage of children (12-23 months) fully immunized, c) % of children able to write alphabets, d) % of women reporting attended Nutrition and health education (NHE) meetings, e) % of mother reporting seeking help from AWW when their child gets sick, f) % of mother reporting received deworming tablets from AWC and g) Average attendance (number of children aged 3-6 years).
- 2) % of AWC getting help from panchayat (HP).
- 3) % of AWC getting help from village leaders (HV).
- 4) % of AWC getting help from women's group (HW).
- 5) % of AWC getting help from mothers of beneficiary children (HM).
- 6) % of AWW who are illiterate.
- 7) % of AWW whose education level is primary.
- 8) % of AWW whose education level is high school level.

- 9) % of AWW whose education level is graduate and above.
- 10) % of AWW reside within 1 kilometer.
- 11) % of AWW reside within 5 kilometers.
- 12) % of AWW reside within more than 5 kilometers.
- 13) % of AWC having owned house.
- 14) % of AWC having drinking water within premises.
- 15) % of AWC having toilet facility.

The column 1 of table 1; indicates the overall performance of AWCs of 20 states in India. The data shows that out of 20 states only 13 have shown their performance index above 0.5. On the other hand, 7 states perform below 50% of their projected services. In another side, among relatively well performer districts no one cross their performance level above 75%. Therefore, we are far behind from the achievements of our 100% goal. Now we shall consider another time series data (table:2) on financial assistance to ICDS programme from government side. This is national level data on Budget allocation and Actual Expenditure under ICDS scheme during the Eleventh Plan.



**Table 2: Budget allocation and Expenditure under ICDS scheme during the Eleventh Plan (Rs. In Crores)**

Year	Budget estimate (BE) <sup>1</sup>	% Growth of BE <sup>2</sup>	Revised estimates (RE) <sup>3</sup>	% Growth of RE <sup>4</sup>	Actual Expenditure AE <sup>5</sup>	% Growth of AE <sup>6</sup>
2007-08	5293		5396.30		5257.09	
2008-9	6300	19.03	6300.00	16.75	6379.36	21.35
2009-10	6705	6.43	8162.00	29.56	8157.76	27.88
2010-11	8700	29.75	9280.00	13.70	9763.11	19.68
2011-12	10000	14.94	14048.40	51.38	14272.21	46.19

Sources: Column 1,3,5; 11<sup>th</sup> Five Year Plan, also available in Annual Report 2016-17, Ministry of Women and Child Development, Government of India and column 2,4,6; calculated by the researcher.

The table 2; and corresponding figures (Fig. 1,2, & 3) show that throughout the year from 2007-08 to 2011-12,



Figure 1

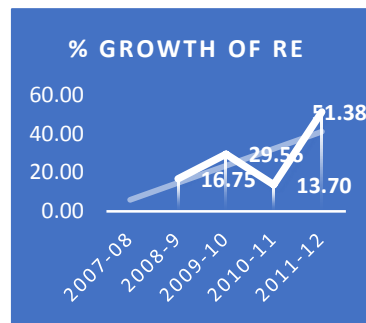


Figure 2

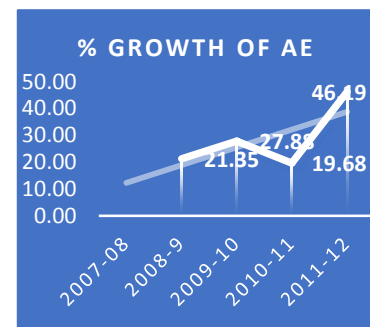


Figure 3

both budget estimate and actual expenditure on the scheme have grown with positive magnitude. Though, the percentage growth of Budget estimate has decreased from 19.03% in 2008-09 to 14.94% in 2011-12 but, the actual expenditure on this project has increased from 21.35% in 2008-09 to 46.19% in 2011-12. This however done through revised estimate in corresponding years. So, it is a significant development from expenditure side.

Therefore, the social audit of this project definitely can demand a continuous positive growth of service performance of the AWCs as well as AWWs. But the above information (performance

index, column 1 of table 1) does not show the satisfactory result in this field. This is the point from which our discussion may start. **The**

**objective of our present study is to find out the basic loophole of the project for which it deviates from its goal.**

Let us now consider another set of information (table-3) consisting marital status, age and job-oriented training of AWWs of the 20 states.

**Table 3; State wise information about AWWs**

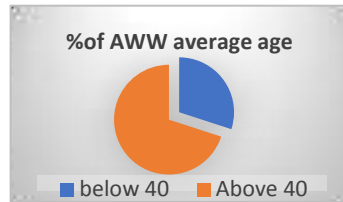
	Average age of AWW	% of unmarried AWW	% of married AWW	% of AWW gets job training
Andhra Pradesh	35	7.2	81.9	100
Assam	37	12.5	85.3	97.2
Bihar	37	2.2	92.2	91.7
Chhattisgarh	41	12.9	73.9	58.5
Gujrat	37	1.9	95.8	95.1
Haryana	41	0.8	95.3	100
Himachal Pradesh	36	1.2	87.5	52.5
Jambu & Kashmir	39	3.8	96.2	62
Jharkhand	36	6.6	87.3	100
Karnataka	36	15.5	80.1	64.1
Kerala	41	9.5	87.1	90.6
Madhya Pradesh	39	10.1	68	80.9
Maharashtra	42	2.9	88.7	99.7
Orissa	39	21.8	70.9	98.3



<b>Punjab</b>	39	13.6	78.6	29.2
<b>Rajasthan</b>	36	14.3	77.5	100
<b>Tamilnadu</b>	47	8.1	86.8	96
<b>Uttar Pradesh</b>	37	6.8	83.5	57.1
<b>Uttaranchal</b>	33	6.8	93.2	85.4
<b>West Bengal</b>	42	12.4	85.4	98

Source: Evaluation Study on Integrated Child Development Schemes (ICDS), Volume-1, Programme Evaluation Organization, Government of India, New Delhi, March 2011. Compiled by researcher.

The table shows that, the average age of AWWs range from 33 to 47. The marital status of AWWs shows that in almost all states more than 80% are fall into married category. In case of job training, we see a hopeful picture. In this field there are only four states including Chhattisgarh, Himachal Pradesh, Punjab and Uttar Pradesh where below 60% AWW have gotten training. Among these four, picture of Punjab is worst. There is only 29.2% of AWWs have trained.



Now, keeping the view towards objective of the study, and for sake of simplicity of explanation, four indexes have been made from table 1, which are;

- 1) Index of External Assistance (IEA)
- 2) Index of physical infrastructure facility (IPI)
- 3) Index of Educational qualification (IEQ)
- 4) Index of distance barrier (IDB)

Next, we shall clarify all these four indexes one by one;

**Index of External Assistance (IEA):** It has calculated by the simple average of external helps getting by the AWCs from four institutions like, local Panchayat, village leaders, Women's group and Mothers community. These institutions provide helps to AWCs in the form of motivation, monitoring and required infrastructure facility. i.e.,  $IEA = \frac{\sum_{i=1}^4 H_i}{400}$  where,  $H_i$  stands for % of AWC getting help/assistance from different external institutions.

**Index of physical infrastructure facility (IPI):** Index of average infrastructure facility has calculated by the simple average of three types of infrastructures

available to AWCs. These are like 'Owned Housing facility', 'source of Drinking water' within the premises and 'good toilet facility'. Therefore,  $IPI = \frac{\sum_{i=1}^3 P_i}{400}$  Where,  $P_i$  stands for % of AWCs having different infrastructure facilities mentioned above.

**Index of Educational qualification (IEQ):** The educational index has made by the weighted average of percentage AWWs at each level of education. Here, four-point scale has been used. The study considers weights (or relative impact of education on ICDS programme) for each stage of education as: Illiteracy (level-0) =0, Primary (level-1) =1, High School (level-2) =2 and Graduate (level-3) =3. Then the formula became;  $IEQ = \frac{\sum_{i=0}^4 E_i W_i}{400}$  Where,  $E_i$  stands for percentage AWWs with different levels of educational qualification and  $W_i$  stands for weight of different levels.

**Index of distance barrier (IDB):** It is also a weighted average of percentage AWWs according to distance of their residence from work place. Here the study uses 3-point scale. The study assumes that more distance from work place creates more barrier to provide services. Keeping this in mind the weights are determined as: 2 for distance more than 5 kilometers, 1 for distance more than 1 but less than 5 kilometers and 0 for distance less than 1 kilometers.

Then the formula become;  $IDB = \frac{\sum_{i=1}^3 D_i W_i}{300}$  Where,  $D_i$  stands for percentage of AWWs resides various distances from their work place and  $W_i$  stands for weight for different distance. The following table-3 shows values of four indexes in different states.





**Table 3; Indexes of Four Variables**

Name of States	Index of External Assistance	Index of average physical infrastructure facility	Index of Educational qualification	Index of distance barrier
Andhra Pradesh	0.30	0.46	0.39	0.03
Assam	0.63	0.60	0.31	0.04
Bihar	0.36	0.23	0.35	0.00
Chhattisgarh	0.58	0.73	0.26	0.02
Gujrat	0.38	0.54	0.31	0.09
Haryana	0.14	0.45	0.31	0.01
Himachal Pradesh	0.58	0.62	0.34	0.10
Jambu & Kashmir	0.34	0.28	0.19	0.04
Jharkhand	0.28	0.46	0.32	0.05
Karnataka	0.54	0.52	0.31	0.01
Kerala	0.79	0.74	0.27	0.10
Madhya Pradesh	0.40	0.60	0.29	0.02
Maharashtra	0.53	0.62	0.35	0.04
Orissa	0.48	0.44	0.45	0.07
Punjab	0.22	0.37	0.34	0.05
Rajasthan	0.26	0.39	0.14	0.04
Tamilnadu	0.32	0.79	0.41	0.19
Uttar Pradesh	0.23	0.33	0.38	0.07
Uttaranchal	0.03	0.51	0.55	0.10
West Bengal	0.45	0.46	0.30	0.19

Source: Calculated by the researcher form table-1

Now we have come in to the threshold of operation to reach our primary objective. In order to do this the study uses bi-variate linear regression model. The study has not used multi variate model in order to avoid multi-co-linearity problem. In the study, The Performance index (PI) of AWCs is considered as dependent variable and there are eight independent variables which are; External assistance

(EA), Physical Infrastructure (PI), Educational Qualification (EQ), Distance Barrier (DB), Average Age (AA), Marital Status; Married (M), Un-Married (UM) and professional Training (T). The values of first four available in table 3 and the values of last four are available in column 6,7,8 and 16 of table 1 respectively. The results of regression have shown in table number 4.

**Table 4: Result of bi-variate linear regression (Dependent variable: Performance index (PI))**

Independent variables	Test Statistics				
	$\beta$	Constant	Anova Sig. (P)	R	St. Error
External Assistance to AWC	0.263	0.438	0.263	0.263	0.199
Available physical infrastructure	0.439	0.293	<b>0.053</b>	0.439	0.224
Educational qualification	0.063	0.116	0.792	0.063	0.431
Distance barrier	0.249	0.748	0.289	0.249	0.685
Average Age	0.389	0.020	<b>0.090</b>	0.389	0.011
married AWW	-0.097	-0.002	0.683	0.097	0.005
unmarried AWW	0.056	0.002	0.815	0.056	0.007
Professional training	0.234	0.002	0.321	0.234	0.002

Source: Calculated by the researcher



### Explanation of the Result

The result of the study shows that, among 8 independent variables only two i.e., availability of physical infrastructure (at 95% confidence level) and average age (at 90% confidence level) are significantly correlated with dependence variable (performance of AWCs). The values of  $\beta$  – coefficient for these two are highest and with positive magnitude. Therefore, Infrastructure facility to AWCs and the age of AWWs are most important and influencing factors for service performance of AWCs. In other words, lack of these two are the main obstacles to achieve optimum performance of the them. Interestingly, the result shows higher aged AWWs perform better. This may because, relatively lower aged AWWs suffer from family hazards more and they may suffer from lack of job satisfaction which decreases the level of perfection in their activities for AWCs. For younger AWWs, the opportunity cost for this job is higher than that for older. So, older serve their services more minutely than younger.

Among another six insignificant factors, the variable ‘distance barrier’ has positive co-relation with better performance. This is because, AWWs reside more distance from AWCs have to devote more time in their duty since some how they are free from family matters during the time of service.

The marital status of AWWs show another interesting picture. Here, married is inversely and unmarried is directly co-related with performance. Here also come the concept of family disturbance in the form of dependance (like child caring). So, due to

the freeness from dependance unmarried workers pay more attention to their duties.

Therefore, in several cases family hazards appear as an important obstacle against better performance of AWCs. So, it may be considered as a ‘derivative’ factor for low performance of the programme.

Though insignificant but  $\beta$ -coefficient of other 3 variables i.e., External assistance, Educational qualification and Professional Training are positive. So, they are directly related with workers’ performance.

### CONCLUSION

According to the Mod-value of  $\beta$ -coefficient it is clear that availability of infrastructure, family hazards, external assistance and professional training are most influencing factors respectively. Here, Education plays minimal role for increasing performance. This may because it is relatively low paid job. Higher educated persons have low job satisfaction in this profession and the opportunity cost of their time spent is also higher. The picture for less educated persons is quite opposite. They serve their services with mental satisfaction. Therefore, if we plan for better performance of AWCs then we must have to emphasis on availability of infrastructural facility, payment to AWWs, creche facility (to reduce family hazards) and assistance from local institutions. The performance of this programme needs a holistic support both by the beneficiary and other related institutions.

### APPENDICES

Table: Regression Equations

Dependent Variables	Regression equations
External Assistance to AWC (EA)	PI = 0.438 + 0.263 (EA)
Available physical infrastructure (PI)	PI = 0.293 + 0.439 (PI)
Educational qualification (EQ)	PI = 0.116 + 0.063 (EQ)
Distance barrier (DB)	PI = 0.748 + 0.249 (DB)
Average Age (AA)	PI = 0.020 + 0.389 (AA)
married AWW (M)	PI = -0.002 - 0.097 (M)
unmarried AWW (UM)	PI = 0.002 + 0.056 (UM)
Professional training (T)	PI = 0.002 + 0.234 (T)

### REFERENCES

- (2016-17). Annual Report. Ministry of women and child development, Govt. of India.
- Bank, W. (2013). Helping India combat persistently high rates of malnutrition. World Bank.
- Bashir, A. B. (2014). Evaluation Study of Integrated Child Development Scheme in district Bandipora of Jammu and Kashmir, India. International Research Journal of Social Sciences, 34-36.
- Chudasama, R. K. (2015). Evaluation of Anganwadi centres performance under ICDS Programme in Gujrat, India during year 2012-13. Journal of Mahatma Gandhi Institute of Medical Sciences, 60-65.
- FOCUS. (2006). Citizens' Initiative for the Rights of Children Under Six. New Delhi: FOCUS.
- Gupta A, G. S. (2013). ICDS Scheme: A Journey of 37 years. Indian Journal of Community Health, 25(1), 77-81.



7. Gupta J.P., M. U. (1979). *A study of the Functioning of Anganwadi Workers of ICDS. Delhi: NIHFV.*
8. Lal, D. S. (n.d.). *National Health Programme Series 7, Integrated Childhood Development Services. New Delhi: National Institute of Health and Family Welfare.*
9. Monica Dasgupta, M. L. ( 2005, June). *The World Bank, World Bank Policy Research Working Paper 3647. Development Research Group.*
10. NFHS-4. (2015-16). *International Institute for Population Science. International Institute for Population Science.*
11. NFHS-4. (2015-16). *International Institute for Population Sciences. Mumbai: International Institute for Population Science.*
12. Retherford R.D., S. K. (2001). *Promoting institutional deliveries in rural India: The roll of antenatal-care services. New Delhi: National Family Health Survey.*
13. Science, I. I. (2007). *NFHS India 2005-6 Report-3. Mumbai: International Institute of Population Science.*
14. Sciences, I. I. (2000 ). *NFHS India Report-2 . Mumbai: International Institute of Population Sciences.*
15. UNICEF. (2017). *Malnutrition. UNICEF.*
16. Welfare, D. o. (2012-13). *ICDS, State Annual Programme Implimentation Plan. Govt. of West Bengal.*



# ON THE PROBLEM OF LANGUAGE BORROWING (ON THE EXAMPLE OF THE RUSSIAN LANGUAGE)

Surojbek Ruzmetov

PhD student, Urgench State University (Uzbekistan)

## ABSTRACT

*This article addresses the issue of borrowing language units from other languages by Russian. It is important to note that the problem of borrowing language units from one language to another is one of the controversial issues in modern linguistics. It also provides a comparative description of the views of some linguists on the process of language borrowing, its causes, and the designation of similar elements in the Russian language. Following Zemskaya E.A., it is asserted that the formation of new words from the Russian language borrowed with the help of dictionary educational means is a condition of "russification", and such education must be attributed to original words. Examples are given of words formed by combining the borrowed basis with Russian word forming elements. The main reasons for borrowing in the work are confirmed to be extra-linguistic (economic, political and other relations between the native speaker people of the successor language and the people of the source language) and linguistic (the language's need to identify new phenomena).*

**KEYWORDS:** *borrowing, foreign words, lexical unit, source language, successor language, Russian, anglicism, adaptation, reasons for borrowing, internal language needs.*

## INTRODUCTION

The question of borrowing elements, words and whole word combinations from one language to another is a controversial issue in linguistics. By following the borrowing process, you can obtain valuable information about the development of the language in general. This problem has been and continues to be of interest to linguists from different nations.

For the first time the problem of language interaction and interpenetration of elements was considered in the works of the Baudouin de Courtenay I.A. (1875) (Geranina, 2008, pp. 101-102).

The essence of the process of borrowing is treated differently by researchers. Let us consider the basic interpretations of the concept of borrowing. Some linguists understand borrowing to mean the process of "moving" lexical units from one language to another (Krysin L.P., Mayorov A.P., etc.), others to mean words obtained as a result of the process of mastering foreign words (graphic, phonetic, morphological design) (Akhmanova O.S., Marinova E.V., etc.). Rosenthal D.E. understands borrowing much more widely - as "the words which are entering into Russian language from other languages, as a result of economic, political and cultural communications of Russian people with other states ... They also can arise as consequence of snobbism, a fashion" (Rosenthal, 2001, p. 69).

## RESULTS AND DISCUSSIONS

An equally controversial issue in linguistics is the designation of words of foreign origin. Lotte D.S. notes that such words in Russian have several designations: *foreign words, foreign language words, foreign borrowings, foreign borrowings*, etc. Previously, the terms foreign words and foreign words were also used (Lotte, 1982, p. 9).

In considering this issue, some researchers are even trying to differentiate these concepts from each other. For example, Yartseva V.N. contrasts foreign words, sound, spelling, grammatical and semantic features of which are alien to borrowed words learned in the language (Yartseva, 2002, p. 158).

In our opinion, the concepts of "borrowed word" and "foreign word" are absolutely identical: in both cases, a foreign word penetrates the language and is shaped accordingly. Here we only have to distinguish between the types of borrowings by the degree of adaptation in the language, under which we distinguish between fully acquired borrowings and words that are partially adapted. In the first case, the word can serve as a producing base (*рыцарь – рыцарство* (knight – knightly), *рыцарский – по-рыцарски* (chivalrous - chivalrously)), in the second case, it is understandable to native speakers and is graphically arranged, but its derivative potential is



zero (*дедлайн, стартап, логин* (deadline, start up, login)).

Thus, the problem of borrowing lexical units is one of the most pressing in linguistics, the appearance of which is connected with the process of language interaction (Khokhonin, Ovsyannikova, 2017, p. 10). Indeed, the penetration of borrowings into a certain language is due to contacts between carrier nations. With regard to the designations of the language to which the borrowed word refers and the receiving language, there are several terms in linguistics:

- 1) Source language, base language, transmitter language, donor language, etc;
- 2) The successor language, the borrowing language, the recipient language, etc.

Of these, we prefer to use the terms "source language" and "successor language", considering them clearer from a semantic point of view.

Foreign-language borrowings are the subject of research in many sciences and branches, as well as their terminology systems. It should be noted that the issue of foreign language borrowing has been now taken on particular importance in view of the increasing globalization of science. Now more than ever, there is a real need for a detailed, in-depth analysis of this phenomenon, based on ample practical material.

As Yuypin Ch. correctly notes, "*there is no language that is completely free of foreign language phenomena, because no nation in today's world lives completely isolated*" (Yuypin, 2015, p. 87). This is also confirmed by the words of the great Russian linguist Reformatsky A.A., who points out that there is not a single language in the world a lexicon of which consists only of original words: each language has a layer of borrowed words (Reformatsky, 2004, p. 139). Politicians that do not accept this axiom sometimes artificially create a tendency at the legislative level to prohibit borrowing, for example, in Iceland the use of foreign language inclusions and borrowings is restricted by law (Kolomejtsjeva, 2014, p. 185).

If borrowing is considered the result of economic, political, cultural, sports and other relationships, its penetration into the language is necessary for language development. Some governmental and non-governmental organizations are trying to taboo borrowed words, particularly in Russia. One example is the LDPR's initiative to ban the use of foreign words in the media by journalists (Forbes, 2013) or the British petition to ban Americanism (BBC, 2017).

If we look back at the history of the fight against borrowing, Valgina N.S. notes that in the 40s of the 20th century they were evaluated as ideologically alien elements, the use of which in speech was equated with anti-patriotism (Valgina, 2001).

Thus, the "fight" against foreign-language borrowing has been carried out before, but today it is becoming increasingly important, as evidenced by its inclusion even in the election programmes of some presidential candidates.

The borrowed word, organically included in the Russian language system, can be subject to semantic transformations, grammatical transformations, phonetic learning, as evidenced by the following opinion of Khokhonin D.E. and Ovsyannikova K.V.: "*Some borrowings have been so organically included in the lexical system that they are perceived as native Russians*" (Khokhonin, Ovsyannikova, 2017, p. 10).

The proof of the "russification" of a borrowed word is the formation of new words from it with the help of the original word-generating means. Examples of such words typical of older generation speech include: **аэродром** (aerodrome) (French: *aerodrome* ← Greek: air + dromos: running) - territory for parking, take-off, landing and maintenance of aircraft, aviation units or subdivisions; **мануфактура** (manufacture) (manufaktura ← lat. manus - hand + facere - to do) - industrial enterprise where hand tools are used; **танцкласс** (dance class) (German tanzen - dance + Klasse - class) - dance school.

Unlike Goncharova N.A. and Shvetsova V.M., who believe that "*such a way of enrichment as borrowing enriches only the foreign part of the language, while the native part remains intact*" (Goncharova, Shvetsova, 2017, p. 6), we consider the adjectives **аэродромный** (airfield-related), **мануфактурный** (manufactural), **танцклассный** (dance class-related), **танцклассовый** (dance class-related), generated from these words to be Russian, because they are based on Russian word morphs. In this regard, Zemskaya E.A. notes that "*the use of a foreign word as a basic basis is an additional indicator of its entry into the Russian language system*" (Zemskaya, 2017, p. 14).

When the question of the reasons for the borrowing arises, it should be noted that there are two types of reasons for the borrowing - extra-linguistic (foreign language) and linguistic (intra-linguistic). The first has to do with the economic, political and other relations between the mother tongue of the successor language and the source language, while the second has to do with the need for the language to identify new phenomena or new meanings of multiple words. In our opinion, the reasons for borrowing language units are in most cases interrelated.

Bukina L.M. considers "*historical contacts of peoples, wars, establishment of international corporations and organizations, migration of peoples, the nature of relations between different nations, the high prestige of language in the world or*





*international arena, scientific and technical progress*" to be extra-linguistic factors in borrowing foreign words (Bukina, 2016, p. 92). In our opinion, apart from the factor of war, all these factors may involve a lot of borrowing in the language. This also includes integration in the cultural, educational, political and tourism services sectors. In particular, the higher education sector has been enriched in the first two decades of the 21st century with the latest borrowings indicating new methods of learning (*инсерт, синектика, синквейн* (insert, synectics, cinquain)), the names of bachelor's areas ("*Аудио-видеотехнологии*", "*Дефектология*", "*Энергетика*" ("Audio-Video Technology", "Defectology", "Energy") and master's specialities ("*Биотехнология*", "*Геотектоника и геодинамика*", "*Ихтиология и гидробиология*" ("Biotechnology", "Geo-tectonics and Geodynamics", "Ichthyology and Hydrobiology")).

In their turn, Volkov S.S. and Senko E.V. prefer the trend of "language saving", which is the replacement of long word combinations with single word names (Volkov, Senko, 1983, p. 48). For example, the word *veteran*, which often accompanies the names of older people (from Lat. *veteranus* ← *vetus* old, tried and tested) - 1) an older person who took part in a war; 2) a person who has worked for a long time in a company or field.

When investigating the reasons for borrowing, Valgina N.S. distinguishes between the following types:

1) The need to name new things, phenomena, concepts (*компьютер, факс* (computer, fax));

2) The need to differentiate notions (the player, unlike its Russian equivalent "*проигрыватель*", is equipped with headphones);

3) Necessity to specialise in concepts (*риэлтор* (realtor) - entrepreneur engaged in real estate);

4) "Established" language as the basis for a particular terminology industry (e.g. the basic computer language, sports terminology is English);

5) Need for euphemistic replacement (*pediculosis* instead of its Russian equivalent "*вшивость*" (lice));

6) The desire for a fashionable word with the meaning of "elitism" (a boutique instead of a Russian equivalent "*маленькая лавочка*" (small shop)) (Valgina, 2001).

Thus, the borrowing of an element of one language from another may be due to one or more reasons, and many works in Russian linguistics are devoted to this research. In our opinion, the most detailed wording of the reasons is given by Valgina N.S.

As we mentioned above, by analysing the "path" of individual borrowed units, we can obtain valuable information about the pace of language development as a whole. Thus, the Russian language, like other languages that are open to mutual contact, is experiencing a rapid process of loan penetration. In a short period of time, foreign elements, once they have fully acquired it, can move into an active vocabulary. This process can be traced back to the following concrete example, which proves the pace of language development.

For example, in her article published in 2003, Vorobyeva S.V. writes that "words and units such as *browser, chat, internet* and *on-line trading* have not yet been fully acquired by Russian" (Vorobyeva, 2003, p. 117). Now, after 16 years, we have seen that these units have been fully acquired by the Russian language in both graphic (*браузер, чат, интернет, онлайн-торговля* (browser, chat, internet, online trading)) and word-generating relationships (*браузерный, чатовый, интернетовский, интернетный, онлайн-переводчик, онлайн-игра* (browser-related, chat-related, internet-related, internet-related, online translator, online game, etc.)).

It should also be added that units such as "*on-line trading*" were named by Krysin L.P. as the words "centaurs", since they consist of different, difficult-to-compatible (and yet combined) parts. As examples, the scientist cites the words *ТВ-программа, PR-служба, IQ-тесты, PIN-код, SIM-карта, SMS-сообщение, e-mail-адрес, WWW-страницы* (TV programme, PR service, IQ tests, PIN code, SIM card, SMS, e-mail address, WWW pages (Krysin, 2010, p. 575). Of course, after 10-15 years these dictionary units ("centaurs") can be acquired by Russian, which also depends on the pace of development, "acceptance" of these units by native speakers and other circumstances.

Looking at the composition of borrowings in Russian by source language, it should be emphasised that they are dominated by units borrowed from English, the first of which were recorded in Russian by Russian ambassadors to the court of the English kings Elizabeth I and James. The reason for this was the linguistic necessity to use borrowings when drafting reports to the government, where they were used to denote subjects and concepts that did not exist in the Russian state. There are plenty of examples of such penetration into the language of "foreign" elements due to the extra-linguistic factor, in particular, diplomatic relations between peoples in each language.

At present, the vocabulary of many languages is being replenished with Anglicisms (Bukina, 2016, p. 92), the reason for which is the process of globalization covering all spheres of human life: politics, economics, culture, education,



spiritual and moral development, language (Vlasova, 2016, p. 72).

In addition, anglicisms are used in Russian not only as terms or names of concepts that do not exist in Russian reality, but also as an imitation of Western culture (Vlasova, 2016, p. 73). Indeed, especially youth slang is penetrated by a large mass of "foreign" elements, as it represents one of the most open and dynamic systems. For example, instead of the Russian word (sorry), young people began to use an anglicism *соpи* (sorry), *покупка* (shopping) is replaced by *шопингом* (shopping), *песня* (the song) is replaced by a *трек* (track), etc. In addition, anglicism began to displace not only native Russian words, but also borrowings from other languages that had long adapted to it (*прайс-лист* (price list) instead of the German word, *прейскурант* (Preiskurant); *постер* (poster) instead of the French word *плакат* (placard), *тренд* (trend) instead of Latin word *тенденция* (tendency), etc.). It should be noted that some researchers (Krysin L.P., Fedorova I.O., Levikova S.I., Rubtsova E.A., etc.) consider the trend towards foreign language borrowing as a "clogging" of the language.

However, as Valgina N.S. points out, on a wave of satisfying the needs of the language, a lot of verbal junk has surfaced that clogs the language. As an example of such "unnecessary" words, the author cites conversion lexemes *конверсия*, *стагнация*, *консенсус*, *имидж* (stagnation, consensus, image) that have a corresponding equivalent in Russian (Valgina, 2001).

Indeed, the language does not need to borrow similar, overlapping meanings of native Russian or words previously learned from one language or another. This trend, in our opinion, may cause artificial obsolescence, the transition to a passive vocabulary of native dictionary units. Speech oversaturation with borrowings, as Apresyan Yu. D. believes, "is a hallmark of semi-educated language knowledge" (Apresyan, 1992, p. 51).

In considering this question, another author notes that "people want to stand out in everything - to dress in a non-standard way, to behave in an American manner, to use in their vocabulary words, meanings of which are known only to a few" (Sidakova, 2016, p. 112). We may find the opposite in Bukina L.M., who points out that "the knowledge and use of foreign words in speech emphasises the speaker's education and erudition. This gives him some self-confidence, enhances his psychological status and emphasises his belonging to a higher status group" (Bukina, 2016, p. 96).

One can agree with all researchers in a certain sense, since nowadays, as a result of the pursuit of language fashion, some members of society allow themselves to use borrowed units, despite their stylistic unjustifiability and redundancy.

Dmitrieva O.A. notes in this regard, "Speaking about the frequency of reproduction of a language unit, it is necessary to distinguish between fashion and parasitism associated with the ultra-frequency use of a language unit, possibly fashionable" (Dmitrieva, 2014, p. 536). It was to describe such abuses of foreign words that the concept of "macaronic language" arose among people to describe speech that is replete with unjustified borrowings.

Nowadays, English is becoming the main language of communication between different peoples of the world. Moreover, its elements have become quite common in the press, and by penetrating into the "legislative lexicon" of the language they are strengthening their position. An example of this is the words *грант* (grant) and *инфраструктура* (infrastructure), which have now managed and internationalised. Let us look at the meanings of these words:

- **грант** (grant) – additional financing of institutions and cultural figures, scientific research on a competitive basis;

- **инфраструктура** (infrastructure) - (infrastructure formed from lat. infra - under, + structura - structure, order), etc.

These words have penetrated the Russian language from or through English. Examples of the use of these words in official document titles:

- Decree of the President of the Russian Federation No. 30 of January 30, 2019 "On the Presidential **Grants** for the development of civil society";

- Federal Law No. 214-FZ of 29 July 2017 "On conducting an experiment to develop resort **infrastructure** in the Republic of Crimea, Altai Territory, Krasnodar Territory and Stavropol Territory".

It is important to note that the meaning of the abovementioned borrowings does not cause difficulties for native speakers of the Russian language, as at present almost everybody is aware of political events, economic reforms and is interested in the latest news, which means that these foreign language words are constantly on the human ear.

At present, anglicisms are replacing not only native Russian words, but also long adapted borrowings from other languages (*сэндвич* (sandwich) instead of the German word *бутерброд* (Butterbrot); *дисплей* (display) instead of the French word *экран* (écran), etc.) (Valgina, 2001).

## CONCLUSION

The phenomenon of borrowing foreign language elements is therefore driven by the internal needs of the language and the state's ties with foreign countries. Given that the language is characterised by certain norms and restrictions, the use of borrowing in speech must also comply with the norms. First of



all, in order to avoid communication failures, it is necessary to use the units already adapted to the native language and secondly, it is necessary to pay attention to the justifiability of including a "foreign" word in speech.

## REFERENCES

1. Apresyan Yu. D. (1992). *O sostoyanii russkogo yazika [On the condition of the russian language]* (pp. 51-52). Moscow: Russkaya rech. (In Russ.).
2. BBC (2017). *How Americanisms are killing the English language*. Retrieved November 22, 2020, from <http://www.bbc.com/culture/story/20170904-how-americanisms-are-killing-the-english-language>
3. Bukina L. M. (2016). *Vneshnyaya i vnutrinnyaya obuslovlennost' yazykovogo zaimstvovaniya [External and Internal Conditionality of Language Borrowing]*. *Verstnik RUDN, Linguistics Series*, Vol. 20, No. 1, 89-99. (In Russ.).
4. Dmitrieva O.A (2014). *Yazykovaya moda kak povedencheskiy regulativ [Language fashion as a behavioral regulator]*. *New trends in education and science: the experience of interdisciplinary research: Material of all-Russian scientific-practical conference*. Rostov-on-Don: pp. 535-538. (In Russ.).
5. Forbes (2013). *LDPR predlozhila zapretit ispolzovat inostrannye slova v SMI [LDPR proposes to ban foreign word in Mass Media]*. (In Russ.). Retrieved November 22, 2020, from <https://www.forbes.ru/news/233265-ldpr-predlozhila-zapretit-ispolzovat-inostrannye-slova-v-smi>
6. Geranina I. N. (2008). *O termine «zaimstvovanie» [About the term "borrowing"]* *Izvestiya PGPU [PSPU News]*, no. 6 (10): pp. 101-103. (In Russ.).
7. Goncharova N. A., & Shvetsova V. M. (2017). *Inoyazychnyye slova v rodnoy rechi: obogashcheniye yazyka ili simvol chuzhoy? [Foreign words in native speech: enrichment of a language or a symbol of someone else's?]*. *Neophilology*, No. 14: pp. 5-10. (In Russ.).
8. Khokhonin D.E., & Ovsyannikova K.V. (2017). *Spetsifika funktsionirovaniya varvarizmov v russkoy rechi [The specifics of the functioning of barbarisms in Russian speech]*. *Linguistics and intercultural communication*, No. 2 (25): pp. 10-15. (In Russ.).
9. Kolomejtseva Ye. B. (2014). *Funktsionirovaniye inoyazychnykh vkrapleniy v razlichnykh stilyakh rechi [Functioning of foreign language inclusions in various styles of speech]*. *Vestnik of Omsk University*, No. 4: pp. 185-187. (In Russ.).
10. Krysin L. P. (2010). *O Nekotorykh novykh tipakh slov v russkom yazyke: slova-"kentavry" [About Some new types of words in Russian: words - "centaurs"]*. *Vestnik of the Lobachevsky State University of Nizhni Novgorod*, No. 4 (2): pp. 575-579. (In Russ.).
11. Lotte D.S. (1982). *Voprosyi zaimstvovaniya i uporyadocheniya inoyazychnykh terminov i terminoelementov [Issues of borrowing and streamlining foreign terms and term elements]*. Moscow. (In Russ.).
12. Reformatsky A. A. (2004). *Vvedenie v yazykovedeniye [Introduction to Linguistics]*. Moscow: Aspekt Press Publ. (In Russ.).
13. Rosental D. E. (2001). *Spravochnik po russkomu yazyku. Prakticheskaya stilistika [Handbook of the Russian language. Practical styling]*. Moscow, Oniks Publ. (In Russ.).
14. Sidakova N.V. (2016). *Upotrebleniye inostrannykh slov v russkom yazyke: logika rechi ili dan' mode? [The use of foreign words in Russian: the logic of speech or a tribute to fashion?]*. *Baltic humanitarian journal*, No. 4 (17): pp. 111-114. (In Russ.).
15. Valgina N. S. (2001). *Aktivnyie protsessyi v sovremennom russkom yazyke [Active processes in modern Russian]*. Moscow: Logos Publ. Retrieved November 22, 2020, from <http://www.hi-edu.ru/e-books/xbook050/01/>
16. Vlasova K. A. (2016). *K voprosu ob anglitsizmah: leksiko-semanticheskiy aspekt [On the question of anglicisms: lexical and semantic aspect]* (pp. 72-74). *Filologicheskoye Naiki. Voprosi teorii i praktiki*, No. 9 (63). Tambov: Gramota. (In Russ.).
17. Volkov S. S., & Senko E. V. (1983). *Neologizmy i vnutrenniye stimuly yazykovogo razvitiya. // Novyye slova i slovni novykh slov [Neologisms and internal stimuli of language development. // New words and dictionaries of new words]* (pp. 43-57). Leningrad: Nauka. (In Russ.).
18. Vorobyeva S. V. (2003). *Anglitsizmy v russkom yazyke: ulitsa s odnostoronnim dvizheniyem? [Anglicisms in Russian: a one-way street?]*. *Russian Language and Literature*, No. 8: pp. 117-122. (In Russ.).
19. Yuyin Ch. (2015). *Inoyazychnyye zaimstvovaniya v sovremennom russkom yazyke [Foreign borrowing in modern Russian]*. *Vestnik Novosibirskogo gosudarstvennogo pedagogicheskogo universiteta [Vestnik of the Novosibirsk State Pedagogical University]*, no. 4 (26): pp. 86-93. (In Russ.).
20. Yartseva V. N. (2002). *Lingvisticheskiy entsiklopedicheskiy slovar [Linguistic Encyclopedic Dictionary]*. Moscow, Bolshaya Rossiyskaya entsiklopediya Publ. (In Russ.).
21. Zemskaya E.A. (2006). *Aktivnyie protsessyi v russkom slovoobrazovanii nashogo vremeni [Active processes in the Russian derivation of our time]*. *Acta Neophilologica [Acta neophilologica]*, No. 8: pp. 9-21. (In Russ.).





# SATISFACTION OF MALE AND FEMALE TEACHERS IN INDIAN HIGHER EDUCATION: A REVIEW

Sapna<sup>1</sup>, Anjali Gupta<sup>2</sup>, Smita<sup>3</sup>

<sup>1</sup>Assistant Professor, Institute of Management Studies and Research,  
Maharshi Dayanand University, Rohtak, 124001, India

<sup>2</sup>Research Scholar, Institute of Management Studies and Research, Maharshi Dayanand University,  
Rohtak, 124001, India

<sup>3</sup>HR Executive, Sudarshan Foundation, Greater Noida, 201306, India

## ABSTRACT

*A vibrant higher education system is the foundation for development of human capital for a country. India has the third largest higher education system in the world. The outcomes of higher education for students have been below expectations. The asset driven higher education system has ignored the teacher job satisfaction. The paper reviews the job satisfaction of male and female teachers in Indian higher education. Gender disparity at workplace is a challenge for inclusive growth. Human resource policies for teacher can be made more inclusive and sustainable by understanding the intrinsic and extrinsic factors influencing job satisfaction of male and female teachers. The regulatory framework needs to fix the issues concerning job satisfaction of teachers irrespective of gender. Human resource policies need to be made flexible so that both male and female faculties are able to explore means of achieving job satisfaction. Only a satisfied and motivated teacher can produce creative and innovative human capital competent to lead organizations.*

**KEYWORDS:** India, Higher Education, Job Satisfaction, Male, Female, Teachers

## 1. INTRODUCTION

Socio-economic development of the country is significantly influenced by higher education system. India was known to have higher education institutions of fame in the forms of Nalanda, Taxila and Vikramshila. Students from different countries used to come to these institutions for higher education (UGC, 2014). In vedic period also the teaching institutions, referred to as *Gurukuls*, were imparting relevant education. The children's from royal families also had to stay in these institutions as hostellers along with other students belonging to different socio-economic class. The teachers (Gurus) were highly respected individuals. Under British rule modern higher education system was established to prepare clerks for British administration by Lord Macaulay. After many decades of Independence, we still continue with the same legacy of producing graduates with low critical thinking skills. It was argued by Yashpal that University is a place to develop analytical and questioning attitude and continuous exercise of reason (Yash Pal, 2009). Hofstede study found prevalence of high power distance in India (Hofstede, 2014). The entry of private players has provided more options to students for pursuing higher education (Tiwari & Anjum,

2013). The Indian higher education not only performs badly in international rankings but domestically also the acceptance of graduates by industry is very poor (Aspiring minds, 2013). There are significant differences between public and private school teacher citizenship behavior (Garg & Rastogi, 2006). There are differences in the belief of male and female teachers (Mills & Smith, 2003). Poor quality of education is a constraint in skill development of students. Poor employment status of educated youth is a badly influencing economic growth in India (Khem Chand et al. 2017). Good teachers are required for developing entrepreneurship skills. Entrepreneurship is crucial for fulfilling the aspirations of young people in India and developing the economy (Choudhary, & Kumar, 2021). Just increasing the supply of private educational institutions would not solve the problems faced by Indian higher education (Anjum & Tiwari, 2012a). Education sector is different from traditional business and it is not easy to manage inorganic growth (Tiwari et al. 2019). Affiliation system has restricted the autonomy of educational institutions and reduced the utility of higher education in India (Sharma et al. 2013). Instead of large private universities, it is better to develop micro, small and medium sized



institutions in higher education. Decentralisation would enhance the access of higher education. Government support has played a constructive role in the development of micro small and medium (MSME) enterprises. MSME sector has an important contribution in development of India (Rana & Tiwari, 2014). MSME model needs to be explored in higher education in India. Intent is more important to enhance the results and satisfaction of employees. Dedication and commitment provides ability to manage challenging operating conditions (Choudhuri et al. 2015). Uniformity has been prominence and this has led to sub optimal efficiency in regional institutions. Demographic factors have a significant impact on satisfaction and effectiveness of teachers (Tiwari & Anjum, 2014a). Women find it harder than men to find a job (Grusky, 1966). China has transformed higher education system which supported the rapid economic growth, but human capital development through higher education reforms has been ignored in India (Tiwari et al. 2017). Entrepreneurship has also been ignored in Indian higher education (Choudhary & Kumar, 2021). A vibrant higher education system will reverse the brain drain and bring students from abroad to develop domestic economy (Tiwari & Anjum 2016). Indian higher education needs to focus on customer, culture, curriculum, creativity and collaboration (Tiwari & Anjum 2014b) instead of relying only on teaching and research publications.

Poor participation of females is another cause of concern. India performs poorly in gender inequality index (GII). India ranks 127 out of 142 countries in gender inequality index (Ray, 2015). Labor force participation rate of females is just 22.5% (Sanghi et al. 2015). Female political leaders account for just 11% seats in parliament in India (NDTV, 2014). Hiring more female teachers will decrease the gender disparity in academic outcomes (Muralidharan & Sheth, 2016). Female teachers are more productive in teaching languages (Chudgar & Sankar, 2008). Simplicity enhances relevance (Tiwari et al. 2018) but simplicity has been overlooked in Indian higher education. Complex procedures have been kept in system to benefit select few individuals and penalize most of the students and teachers. Experience of senior teachers is not utilized properly (Tiwari & Anjum, 2014c). The paper reviews the satisfaction of male and female teachers in Indian higher education.

## 2. ECOSYSTEM OF NEGLECTING TEACHERS REQUIREMENTS

The new national education policy has provided a platform for radical reforms in Indian higher education, but fails to take care of problems faced by teachers. The policy has ignored teacher issues (Pathak, 2021). Industry academia collaboration has not received the required

consideration in policy framework. Collaboration not only enhances skill but provides opportunity for teachers to relate theory with practice and keep their content relevant with the requirements of the industry (Tiwari & Anjum, 2014d) (Role of Higher Education Institutions and Industry Academia Collaboration for Skill Enhancement). Private sector institutions have better industry academia collaboration (Tiwari & Anjum, 2014e). Convey (2010) found that academic philosophy and environment significantly influences job satisfaction of teachers. There is no significant difference in teaching effectiveness of public and private sector higher education institutions (Tiwari & Anjum 2014f). Klassen, Usher & Bong (2010) found that satisfaction is negatively associated with stress.

Mentoring is ignored in Indian higher education. Ignorance of genuine needs of teachers has made them insensitive towards mentoring requirements of students. Though financing is available for paying fees of the institution (Tiwari & Anjum, 2013) but students are not able to access online teaching due to lack of resources to buy gadgets to attend online classes. A student of a prestigious college of national capital committed suicide due to lack of laptop to attend online classes. The insensitive attitude of the administration has converted educational institutions from respected part of society to a neglected part of society. The neglect of teachers has adversely impacted motivation of teachers. Teachers are only concerned with completion of their syllabus and assessments. They do not take much interest in skill development and mentoring of the students. Lack of skills is negatively impacting industry segments and government policies like Make in India (Tiwari & Anjum, 2015). Umme (1999) argued that attitude of teacher significantly affects the job satisfaction. Babu and Reddy (1996) found that higher work load leads to low job satisfaction. Unplanned privatisation of higher education has created distortions in Indian higher education. Though private sector enhances inclusion (Anjum & Tiwari, 2012b) by providing alternative to students who could not get admission in public sector educational institutions but these institutions have become centres of exploitation of teachers. Indian higher education sector cannot be transformed unless teacher's issues are addressed properly (Tiwari & Anjum 2014g). Viel-Ruma, Houchins, Jolivette and Benson (2010) found that self efficacy of teacher influences the job satisfaction. Country first approach should be given priority over profit first approach (Bhatt & Smita 2021) in Indian higher education.

Technology can enhance the satisfaction of teachers. Technology has been underutilised in Indian higher education. Technology driven autonomy can provide teachers to work on multiple projects without need for physically coming to educational institutions and staying there for six to eight hours. Technology will





also benefit the users of educational service. It has been found that technology enhances efficiency and access (Tiwari et al. 2020). Both extrinsic and intrinsic motivation of teachers has been ignored in Indian higher education (Tiwari & Anjum, 2014h). Blended learning can ease work life of teachers by optimising teaching load and maintain work life balance (Mishra & Smita, 2021).

### 3. SATISFACTION OF MALE AND FEMALE TEACHERS

Sharma and Jyoti (2009) found that female teacher were more satisfied. It was argued that higher satisfaction of female teachers is due to nature of job and socio-cultural values of the profession. Sharma and Jyoti (2009) found in a study on teachers of University of Jammu that female teachers were more satisfied. Srivastava and Chabra (2012) in a study on teachers in self financing colleges of education in Greater Noida found that gender did not had any significant impact on the satisfaction of teachers. Patel and Tailor (2005), Naik (1990) also found no difference between satisfaction of male and female teacher. Muralidharan and Sundararaman (2010) argued that performance based pay program will have broad based support among teachers and attract effective teachers into teaching profession. Rana and Soodan (2019) in a study on teachers in Punjab in India found that only 47% teachers were satisfied with teaching as a career. Chaudhary and Malik (2014) investigated satisfaction of teachers in Delhi NCR region and found that female teachers are more satisfied. Seifert, Tricia and Paul (2008) found that female teachers are less satisfied. Bhatia (2012) examined job satisfaction of teachers in Haryana and found that both male and female teachers are less satisfied due to low salaries and job security. Nagar (2012) examined job satisfaction of teachers during times of burnout. It was found that female teachers were more satisfied than male teachers. Female teacher scores were higher on emotional exhaustion and male teacher scores were higher on de-personalization. Mishra and Dkhar (2016) found no significant difference between male and female teachers and teachers of private and public sector. Mishra and Rinsangi (2020) examined job satisfaction of teachers in Mizoram. It was found that there was no significant difference between male and female teachers. Culture influences teachers and entrepreneurs (Tiwari & Anjum, 2014i) Non inclusiveness education system is no sustainable. Sustainable growth needs inclusion of the stakeholders and members of society (Tiwari & Choudhuri, 2015).

Pabla (2012) compared satisfaction of male and female faculties in professional colleges of Punjab. It was found that female teachers are significantly more satisfied as compared to male

teachers. However the satisfaction was not bifurcated into extrinsic and intrinsic factors. Rajareegam and Doss (2013) studied satisfaction of teachers in engineering colleges at Puducherry. It was found that there was no difference between satisfaction of male and female teachers and teachers of different age category. Carke (1997) argued that higher satisfaction of female teachers is attributable to low expectancy.

Lakshmi and Gopinath (2013) found that volume and length of working hours affect work life balance. Married women accepted overtime due to financial considerations. Subha (2013) argued that females prefer teaching due to family engagements, females require career breaks and teaching career provides such opportunity. Ahluwalia and Preet (2014) studied satisfaction of college teachers in Jalandhar and Amritsar cities of Punjab. It was found that the important factors for satisfaction were; possibility of growth, salary, hygiene and infrastructure, possibility of turnover, coordination & cooperation, interpersonal relations, and unbiased administration. It was found that male teachers were more satisfied with salary and perks, whereas female teachers were more satisfied with working conditions and professional growth. A 360 degree performance appraisal system is needed for Indian higher education. (Tiwari, Anjum 2014j). Male teachers are found to be less satisfied (Mwamwanda 1997). Kumar, Anand and Shrivastava (2015) examined satisfaction of faculties in private higher education in Northern India. It was found that overall satisfaction of faculties was very poor. It was recommended that private institutions should give more attention to the environment in addition to monetary factors. Mishra and Dkhar (2016) investigated that job satisfaction of B.Ed college teachers of public and private sector institutions. It was found that there is no significant difference between satisfaction of male and female faculties. No significant difference was found among the satisfaction of faculties of private and public sector institutions. Skills and hierarchy of teachers need to be considered while designing human resource policies (Tiwari, Anjum 2018).

### 4. CONCLUSION

The findings of previous studies give a mixed outcome. Some studies found female teachers to be more satisfied, some found male teachers to be more satisfied. Some studies found no significant difference between job satisfaction of male and female teachers. The inconclusive findings of previous studies indicate a research gap. There is need to further investigate the factors influencing job satisfaction of male and female teachers is a nationwide study, as most of the studies have been done in a narrow geographical region. Equal opportunity for all irrespective of gender discrimination is the need of hour in Indian higher



education. The social needs and aspirations of male and female teachers need to be understood for developing policies for enhancing satisfaction of male and female teachers. The lack of autonomy restricts the growth of teachers. The job design of a teacher needs to be redesigned to provide flexibility to choose activities and responsibilities according to the aspirations of the faculty and skills possessed by the concerned teacher. Work life balance should be given top priority. Only a happy teacher can create happy learners. A country aspiring to reap the demographic dividend cannot afford to have demotivated teachers. The new national policy fails to address the key issues concerning satisfaction of male and female teachers in higher education. The unique aspirations of male and female teachers should be considered while devising gender neutral and gender sensitive human resource policies. Teachers should be allowed to work on start up projects and designing their own courses in an organized framework. The revenue sharing model for all the institutions should be framed so that teachers can undertake consultancy assignments, outsourced assignments to enhance their income. The timing of colleges and universities should be made flexible so that teachers can work on other projects on a revenue sharing model with the concerned institute or university. A major revamp is required in the mindset of the administrators towards the social, emotional needs of the teachers. The research only focus of performance appraisal should be revised to include community work, entrepreneurship, social enterprise, mentoring of students so that teachers can contribute whole heartedly in the development of human capital for the country. Technology should be used as an enabler and soothing tool rather than a barrier and competitor for teachers. Fixing higher education issues should first start with making the system sensitive towards teachers. Empowered and happy teachers will create a new India, where learning will be a mechanism to unleash the hidden potential of a human being and transform India into a knowledge and innovation driven society.

## REFERENCES

1. Anjum B, Tiwari R. (2012a). An exploratory study of supply side issues in Indian higher education. *Asia Pacific Journal of Marketing and Management Review*. 1, 1, 14-24. Available: [https://papers.ssrn.com/sol3/papers.cfm?abstract\\_id=3739008](https://papers.ssrn.com/sol3/papers.cfm?abstract_id=3739008)
2. Anjum, B., & Tiwari, R. (2012b). Role of private sector banks for financial inclusion. *Zenith International Journal of Multidisciplinary Research*. 2, 1, 270-280. Available: [https://papers.ssrn.com/sol3/papers.cfm?abstract\\_id=3833463](https://papers.ssrn.com/sol3/papers.cfm?abstract_id=3833463)
3. *Aspiring Minds*. (2013). *National Employability Report: Graduates Annual Report 2013*, Available: [http://www.aspiringminds.in/docs/national\\_employability\\_report\\_graduates\\_2013.pdf](http://www.aspiringminds.in/docs/national_employability_report_graduates_2013.pdf)
4. Babu, R. & Reddy, B. (1996). Does workload affect the job satisfaction of teachers? *Journals of Indian Education*, XXI 1, 53- 63.
5. Bhatt, A. K., & Smita. (2021). Employability of Students in Indian Higher Education: Challenges and Opportunities. *Asian Journal of Economics, Finance and Management*, 3, 4, 10-17. Available: <https://globalpresshub.com/index.php/AJEFM/article/view/1027>
6. Bhatia A. (2012). Job Satisfaction of SFS Lectures: A Study in Haryana, *International Journal of Social Science & Interdisciplinary Research*, 1, 11.
7. Chaudhary, V., Malik, S. (2014). Demographic and Academic Variables as Correlates of Job Satisfaction of Self Financed Institution Teachers, *Scholarly Research Journal for Interdisciplinary Studies*, II, XIV, 2166-2175.
8. Choudhary, A. K., Kumar, R. (2021). Role of Entrepreneurship in Indian Higher Education: A Review. *International Journal for Innovative Research in Multidisciplinary Field*. 7, 4, 68-71. Available: [https://papers.ssrn.com/sol3/papers.cfm?abstract\\_id=3843088](https://papers.ssrn.com/sol3/papers.cfm?abstract_id=3843088)
9. Choudhuri S, Dixit R, Tiwari R. (2015). Issues and challenges of Indian aviation industry: a case study. *International Journal of Logistics & Supply Chain Management Perspectives*. 4, 1, 1557-1562. Available: [https://www.researchgate.net/publication/329072361\\_ISSUES\\_AND\\_CHALLENGES\\_OF\\_INDIA\\_N\\_AVIATION\\_INDUSTRY\\_A\\_CASE\\_STUDY](https://www.researchgate.net/publication/329072361_ISSUES_AND_CHALLENGES_OF_INDIA_N_AVIATION_INDUSTRY_A_CASE_STUDY)
10. Chudgar, A. & Vyjayanthi, S. (2008). The relationship between teacher gender and student achievement: evidence from five Indian states, *Compare: A Journal of Comparative and International Education*, 38, 5, 627-642, DOI: 10.1080/03057920802351465
11. Clark, A. E. (1997). Job satisfaction and gender: why are women so happy at work?, *Labour Economics*, 4, 341-72
12. Convey, J J. (2010). Motivation and Job Satisfaction of Catholic School Teachers. Paper presented at the Annual Meeting of the American Educational Research Association. April 30- May 4, Denver
13. Garg, P., & Rastogi, R. (2006), Climate profile and OCBs of teachers in public and private schools of India, *International Journal of Educational Management*, 20, 7, 529-541. <https://doi.org/10.1108/09513540610704636>
14. Grusky, O. (1966). Career mobility and organizational commitment. *Administrative Science Quarterly*, 10, 4, 488-503.
15. Hofstede, G. (2014). What about India, Available: <http://geert-hofstede.com/india.html>
16. Khem Chand, Tiwari R, Phuyal M. (2017). Economic Growth and Unemployment Rate: An Empirical Study of Indian Economy. Pragati:



- Journal of Indian Economy*. 4, 2, 130-137. <http://dx.doi.org/10.17492/pragati.v4i02.11468>
17. Klassen, R., Usher, E. L. & Bong, M. (2010). Teachers' Collective Efficacy, Job Satisfaction, and Job Stress in Cross-Cultural Context. *Journal of Experimental Education*. 78(4), 464-486.
  18. Mills, J., & Smith, J. (2003). Teachers' beliefs about effective instrumental teaching in schools and higher education, *British Journal of Music Education*, 20, 1, 5-27.
  19. Mishra, J., Dkhar B. (2016). Job Satisfaction of Teacher Educators: A Study in Relation to Gender and Types of Management, *Katwa College Journal*. Available: [http://www.katwacollegejournal.com/issues/Jugantar\\_Misra-Edu-Research\\_Paper\\_on\\_Job\\_Satisfaction\\_of\\_Teacher\\_Educator.PDF](http://www.katwacollegejournal.com/issues/Jugantar_Misra-Edu-Research_Paper_on_Job_Satisfaction_of_Teacher_Educator.PDF)
  20. Mishra, L., Rinsangi, LI (2020). Job Satisfaction of Degree College Teachers of Mizoram, *International Journal of Management*, 11, 7, 1422-1431. Available: [https://www.researchgate.net/profile/Lokanath-Mishra-2/publication/344160822\\_JOB\\_SATISFACTION\\_OF\\_DEGREE\\_COLLEGE\\_TEACHERS\\_OF\\_MIZORAM/links/5fd371b2299b14088fe8124/JOB-SATISFACTION-OF-DEGREE-COLLEGE-TEACHERS-OF-MIZORAM.pdf](https://www.researchgate.net/profile/Lokanath-Mishra-2/publication/344160822_JOB_SATISFACTION_OF_DEGREE_COLLEGE_TEACHERS_OF_MIZORAM/links/5fd371b2299b14088fe8124/JOB-SATISFACTION-OF-DEGREE-COLLEGE-TEACHERS-OF-MIZORAM.pdf)
  21. Mishra, P., & Smita. (2021). Online Teaching in India during Covid 19: Opportunities and Challenges. *Asian Journal of Sociological Research*, 4, 3, 20-28. Available: <https://globalpresshub.com/index.php/AJSR/article/view/1067>
  22. Muralidharan, K., & Sheth, K. (2016). Bridging Education Gender Gaps in Developing Countries: The Role of Female Teachers, *Journal of Human Resources*, 51, 2, 269-297.
  23. Mwamwenda, T. (1997). Teacher gender differences in job satisfaction in Transkei, *Research in Education*, Available: [www.findarticles.com/p/articles/mi\\_qa3765/is\\_1\\_99711/ai\\_n8775798](http://www.findarticles.com/p/articles/mi_qa3765/is_1_99711/ai_n8775798)
  24. Naik, G.C (1990) Job satisfaction of ad hoc teaching assistants, *Survey of Educational Research*
  25. Nagar, K. (2012) .Organizational Commitment and Job Satisfaction among Teachers during Times of Burnout, *Vikalpa: The Journal of Decision Makers*, 37, 2, 43-60. <https://doi.org/10.1177/0256090920120205>
  26. NDTV. (2014). Election results 2014: 61 women elected to Lok Sabha, Available: <http://www.ndtv.com/elections-news/election-results-2014-61-women-elected-to-lok-sabha-562470>
  27. Patel R. & Tailor P. (2005). A Comparative Study of Teacher Efficiency and Job Satisfaction with Concern to Gender and Work Experience in Rural Area Teacher. Paper Presentation in International Conference of All India Association for Educational Research on Improving Rural Education held in Chennai, Tamil Nadu, India, October, 2005
  28. Pathak R. (2021). National Education Policy 2020: Can it improve Faculty Motivation and Academic Outcomes in India? *International Research Journal of Modernization in Engineering Technology and Science*, 3, 4, 573-579. Available: <https://irjmets.com/rootaccess/forms/uploads/IRJMETs679597.pdf>
  29. Rana, A., & Soodan, V. (2019). Effect of Occupational and Personal Stress on Job Satisfaction, Burnout, and Health: A Cross-Sectional Analysis of College Teachers in Punjab, India. *Indian journal of occupational and environmental medicine*, 23, 3, 133-140. [https://doi.org/10.4103/ijoem.IJOEM\\_216\\_19](https://doi.org/10.4103/ijoem.IJOEM_216_19)
  30. Rana, A., & Tiwari, R. (2014). MSME sector: Challenges and potential growth strategies. *International Journal of Entrepreneurship & Business Environment Perspectives*, 3(4), 1428. Available: [https://papers.ssrn.com/sol3/papers.cfm?abstract\\_id=3833856](https://papers.ssrn.com/sol3/papers.cfm?abstract_id=3833856)
  31. Ray, A. (2015). India ranks 127<sup>th</sup> on gender inequality index out of 142 countries: Report, Available: <http://timesofindia.indiatimes.com/india/India-ranks-127th-on-gender-inequality-index-out-of-142-countries-Report/articleshow/49758677.cms>
  32. Sanghi, S., Srijia, A., & Vijay S. S. (2015). Decline in rural labor force participation in India: A relook into the causes, *Vikalpa: The Journal of Decision Makers*, 40, 3, 255-268.
  33. Seifert, Tricia and Paul U, (2008), *The Effects of Faculty Demographic Characteristics and Disciplinary Context on Dimensions of Job Satisfaction*, *Research In Higher Education*, 49, 4, 357-381.
  34. Sharma, R. D., & Jyoti, J. (2009). Job satisfaction of university teachers: An empirical study. *Journal of Services Research*, 9, 2, 51-64. Available: [https://www.researchgate.net/profile/Jeevan-Jyoti-3/publication/286142423\\_Job\\_satisfaction\\_of\\_university\\_teachers\\_An\\_empirical\\_study/links/583e5e6708aeda6968071146/Job-satisfaction-of-university-teachers-An-empirical-study.pdf](https://www.researchgate.net/profile/Jeevan-Jyoti-3/publication/286142423_Job_satisfaction_of_university_teachers_An_empirical_study/links/583e5e6708aeda6968071146/Job-satisfaction-of-university-teachers-An-empirical-study.pdf)
  35. Sharma H, Tiwari R, Anjum B. (2013). Issues and challenges of affiliation system in Indian higher education. *EXCEL International Journal of Multidisciplinary Management Studies*. 3, 12, 232-240. Available: [https://www.researchgate.net/publication/329072292\\_ISSUES\\_AND\\_CHALLENGES\\_OF\\_AFFILIATION\\_SYSTEM\\_IN\\_INDIAN\\_HIGHER\\_EDUCATION](https://www.researchgate.net/publication/329072292_ISSUES_AND_CHALLENGES_OF_AFFILIATION_SYSTEM_IN_INDIAN_HIGHER_EDUCATION)
  36. Srivastava, S, & Chabra, S. (2012). Job Satisfaction among Teacher Educators: Interplay of Gender and Qualification. *Researcher*. 4, 8, 26-30.
  37. Tiwari, R., Anjum, B. (2013). Role of Education Loan in Indian Higher Education, *GALAXY International Interdisciplinary Research*





- Journal, 1, 2, 89-96. Available: [https://papers.ssrn.com/sol3/papers.cfm?abstract\\_id=3833834](https://papers.ssrn.com/sol3/papers.cfm?abstract_id=3833834)
38. Tiwari R, Anjum B, Khurana (2013). A Role of Private Sector in Indian Higher Education, GALAXY International Interdisciplinary Research Journal. 1, 2, 75-83. Available: [https://papers.ssrn.com/sol3/papers.cfm?abstract\\_id=3833384](https://papers.ssrn.com/sol3/papers.cfm?abstract_id=3833384)
  39. Tiwari R, Anjum B. (2014a). Impact of Demographic Factors on Motivation of University Teachers in North India, Paripex-Indian Journal of Research. 3, 11, 97-99. Available: [https://papers.ssrn.com/sol3/papers.cfm?abstract\\_id=3834203](https://papers.ssrn.com/sol3/papers.cfm?abstract_id=3834203)
  40. Tiwari, Rajesh and Anjum, B. (2014b). Five C Model of Mangement of Indian Higher Education Institutions, International Journal of Social Science & Interdisciplinary Research, 3, 11, 100-105., Available at SSRN: <https://ssrn.com/abstract=3850490>
  41. Tiwari R, Anjum B. (2014c). Impact of Experience of Teachers on Industry Academia Interface in Indian Higher Education, Journal of International Academic Research for Multidisciplinary. 2, 11, 1-9. Available: [https://papers.ssrn.com/sol3/papers.cfm?abstract\\_id=3833472](https://papers.ssrn.com/sol3/papers.cfm?abstract_id=3833472)
  42. Tiwari R, Anjum B. (2014d). Role of Higher Education Institutions and Industry Academia Collaboration for Skill Enhancement, Journal of Business Management & Social Sciences Research. 3, 11, 27-34.
  43. Tiwari R, & Anjum B. (2014e). Industry Academia Interface: A Study of North Indian Universities. International Journal of Marketing, Financial Services & Management Research. 3, 7, 139-146. Available: [https://www.researchgate.net/publication/329072110\\_INDUSTRIY\\_ACADEMIA\\_INTERFACE\\_A\\_STUDY\\_OF\\_NORTH\\_INDIAN\\_UNIVERSITIES](https://www.researchgate.net/publication/329072110_INDUSTRIY_ACADEMIA_INTERFACE_A_STUDY_OF_NORTH_INDIAN_UNIVERSITIES)
  44. Tiwari, R., & Anjum, B. (2014f). Teaching effectiveness in Indian universities: a study of north India, ACADEMICIA: An International Multidisciplinary Research Journal, 4, 12, 50-61. Available: <https://www.indianjournals.com/ijor.aspx?target=ijor:aca&volume=4&issue=12&article=007>
  45. Tiwari, R., & Anjum, B. (2014g). Transformation of Higher Education in India, GE-International Journal of Management Research, 2, 11, 160-168., Available: <https://ssrn.com/abstract=3835079>
  46. Tiwari, R., Anjum, B. (2014h). Motivation of University Teachers in northern India. International Journal of Social Science & Interdisciplinary Research, 7, 273-281. Available: [https://www.researchgate.net/publication/346400719\\_Impact\\_of\\_Demographic\\_Factors\\_on\\_Motivation\\_of\\_University\\_Teachers\\_in\\_North\\_India](https://www.researchgate.net/publication/346400719_Impact_of_Demographic_Factors_on_Motivation_of_University_Teachers_in_North_India)
  47. Tiwari R, Anjum B. (2014i). Impact of Culture in Indian Higher Education on Entrepreneurship. International Journal of Advance Research in Management and Social Sciences. 3, 11, 1-10. Available: [https://papers.ssrn.com/sol3/papers.cfm?abstract\\_id=3833373](https://papers.ssrn.com/sol3/papers.cfm?abstract_id=3833373)
  48. Tiwari R, & Anjum B. (2014j). A Proposed model for Management of Higher Education Institutions. International Journal of Science and Research. 3, 11, 1614-1616. Available: [https://www.researchgate.net/publication/329402339\\_A\\_Proposed\\_Model\\_for\\_Management\\_of\\_Higher\\_Education\\_Institutions](https://www.researchgate.net/publication/329402339_A_Proposed_Model_for_Management_of_Higher_Education_Institutions)
  49. Tiwari R, Anjum B. (2015). Industry Academia Collaboration: Relevance for Make in India, International Journal of Business Management. 2, 1, 840-848. Available: [https://papers.ssrn.com/sol3/papers.cfm?abstract\\_id=3833717](https://papers.ssrn.com/sol3/papers.cfm?abstract_id=3833717)
  50. Tiwari, R., & Choudhuri, S. (2015). The Relevance of Corporate Social Responsibility (CSR) Towards a Sustainable Development: A Case Study of Wipro, Paripex, Indian Journal of Research, 4, 10, 238-240., Available: <https://ssrn.com/abstract=3835063>
  51. Tiwari, R., & Anjum, B. (2016). Role of Tourism in Economic Growth of India, In Kaur, L., Rizwan, S. (Eds.). Corporate Social Responsibility in the Hospitality and Tourism Industry, 225-238. IGI Global. Available: <https://www.igi-global.com/chapter/role-of-tourism-in-economic-growth-of-india/147202>
  52. Tiwari R, Anjum B, Khem Chand, & Phuyal M. (2017). Role of Human Capital and Innovation in Economic Growth: Comparative Study of India and China. International Journal for Research in Applied Science & Engineering Technology. 5(XI), 4042-4048. Available: [https://www.researchgate.net/publication/329072523\\_Role\\_of\\_Human\\_Capital\\_and\\_Innovation\\_in\\_Economic\\_Growth\\_Comparative\\_Study\\_of\\_India\\_and\\_China](https://www.researchgate.net/publication/329072523_Role_of_Human_Capital_and_Innovation_in_Economic_Growth_Comparative_Study_of_India_and_China)
  53. Tiwari, R., & Anjum, B. (2018). Skill Hierarchy Motivation Model for Teachers in Indian Higher Education. Journal of Management and Science. 1, 68-77. Available: [https://papers.ssrn.com/sol3/papers.cfm?abstract\\_id=3835640](https://papers.ssrn.com/sol3/papers.cfm?abstract_id=3835640)
  54. Tiwari, R, Singh, M, Mathur, S. (2018). Sustainability of low cost and simplicity in airline industry: a case of Indigo. International Journal of Management, Technology and Engineering. 8, 12, 6034-6044. Available: [https://papers.ssrn.com/sol3/papers.cfm?abstract\\_id=3833340](https://papers.ssrn.com/sol3/papers.cfm?abstract_id=3833340)
  55. Tiwari, R., Anjum, B., Chand, K., & Pathak, R. (2019). Sustainability of Inorganic Growth in Online Retail by Snapdeal: A Case Study. International Journal of Management Studies. VI (1 (1)). Available: [https://papers.ssrn.com/sol3/papers.cfm?abstract\\_id=3833366](https://papers.ssrn.com/sol3/papers.cfm?abstract_id=3833366)
  56. Tiwari R, Khem Chand, Anjum B. (2020). Crop insurance in India: a review of pradhan mantri fasal bima yojana (PMFBY). FIIB Business Review. 9, 4, 249-255. Available:



- <https://journals.sagepub.com/doi/abs/10.1177/2319714520966084>
57. Umme, K. (1999). A factor analytic study of job involvement of secondary school teachers in Bangalore city. *Experiments in Education*, 28. 9, 159- 163
58. Viel-Ruma, K. , Houchins, D. , Jolivette, K. & Benson, G. E. (2010). Beliefs of Special Educators: The Relationships among Collective Efficacy, Teacher Self-Efficacy, and Job Satisfaction. *Journal Articles; Reports - Research Teacher Education and Special Education*, 33, 3, 225- 233.
59. University Grants Commission (UGC). (2014). *Genesis*, Available: <http://www.ugc.ac.in/page/Genesis.aspx>
60. Yash Pal. (2009). *Report of the Committee to advise on renovation and rejuvenation of higher education*, Available: [http://mhrd.gov.in/sites/upload\\_files/mhrd/files/document-reports/YPC-Report.pdf](http://mhrd.gov.in/sites/upload_files/mhrd/files/document-reports/YPC-Report.pdf)





## GROUPING AND ASSESSMENT OF TOURISM AND RECREATION RESOURCES OF BUKHARA REGION

<sup>1</sup>Ahmadjon Muhamadovich Mavlonov, <sup>2</sup>Istat Elmurodovna Mirzoeva,  
<sup>3</sup>Anvar Nusratovich Nematov, <sup>4</sup>Charos Zarifovna Jalilova

<sup>1234</sup>Bukhara State University, Uzbekistan

Factors such as the well-being and culture of the population and high demographic growth in the world and in some of its countries lead to an increase in demand for tourism, leisure, recreation and recreational resources, which in turn leads to the study of tourism and recreation resources of countries and regions. requires increasing the tourist potential of the regions by assessing the available opportunities.

Today, Uzbekistan has a huge potential for tourist resources, more than 7,000 historical and architectural monuments and beautiful natural and climatic resources. Only 1/3 of tourist resources are used for tourism, and the rest require the formation of tourist infrastructure and the development of new tourism products. Today, like many industries, the tourism industry is developing rapidly. The tourism business cannot be formed only with the available investment, technology, and skilled workers. This will require, first of all, the efficient use of tourist resources.

The importance of natural tourist resources in the grouping of tourism resources is great. The main importance of natural tourist resources is that they serve as tools for the restoration of physical and mental abilities of people. Tourists meet their basic needs from nature. Due to the fact that Bukhara region is located in the desert zone, landscapes (oasis and desert landscapes), climate, water bodies, mineral water and therapeutic swamps play a key role in the organization of tourist activities. These resources can be restored by itself or by man. These resources can be evaluated in terms of geography, biology, geology and other aspects. An analysis of natural tourist resources is required to organize recreation. As natural resources, it is possible to obtain individual components of nature or whole natural complexes.

All natural resources should be viewed in terms of recreational or tourist potential. Recreational resources include natural and anthropogenic objects of unique historical or cultural value, aesthetic

pleasure, therapeutic value, used in the organization of various forms of recreational activities [4, p. 87]. Among modern geographical studies, the study of the recreational potential of regions is one of the important directions today.

Bukhara region is located in the south-west of Uzbekistan, naturally in the south of the Kyzylkum Desert, in the lower reaches of the Zarafshan River [3]. Although the region is developing in the desert zone, it is possible to see a wide variety of recreational resources. Most scientists divide recreational resources into 2 groups [6]:

- Natural recreational resources
- Cultural and historical recreational resources

Natural recreational resources include the natural conditions used in the recreation, recreational and tourism areas of the region and its individual elements (relief, geological structure, climate, surface and groundwater, soils, flora). The potential of historical and cultural resources of the region plays a key role in the development of tourism in the region. Cultural and historical resources can be used for many purposes in tourism. The attractiveness of cultural complexes depends on the ease of use of their historical and pictorial value.

Cultural - historical resources, a complex of various material and cultural monuments are the objects of tourist interest of a particular region.

The richness of the regions in architectural monuments contributes to the development of tourism. It is proposed to preserve cultural and historical resources for tourism as follows:

- Restoration of existing historical sites, buildings and monuments as objects of tourist interest;
- intensification of protection of cultural and historical resources;
- Increasing the responsibility of management organizations in maintaining and improving the environment in order to meet the needs of tourism.

Cultural and historical recreational resources include cultural objects, architectural monuments, archeological monuments, religious sites, shrines,



historically and ethnographically unique places that serve the spiritual and cultural development of people.

It is no secret that Bukhara region is one of the regions rich in cultural and historical recreational resources. More than 700 historical monuments, archeological monuments and sacred places of worship in the region were the basis for the development of historical, religious, pilgrimage tourism.

Although Bukhara region has great potential for tourism development, it is mainly developed historical (sightseeing) and pilgrimage tourism. However, the region has a wide range of opportunities for desert tourism, ecotourism (geotourism), rural tourism, ethnographic, sports, gastronomic, recreational. In particular, the prospects for the development of tourism through the use of natural resources of the region for recreational purposes are great [2].

The natural recreational resources of the region are usually seasonal in nature. In particular, in the spring (especially in April-May) and partly in the fall, you can relax in the desert, restore health, enjoy the beautiful nature of the desert and the unique flora. These recreational activities have been developing relatively rapidly in recent years.

Bukhara region has great potential for the use of natural conditions and resources for tourism and recreation. Studies show that, depending on the natural conditions and opportunities of the region, the following groups can be distinguished:

• In terms of relief forms:

1. Study of plateaus (Karakul) and hills around the oases (Momojurgoti, Oftobachi, etc.);
2. Excursions to anthropogenic hills within the oases;
3. Viewing the ancient terraces of Zarafshan;
4. Study of the relationship between the desert and the oasis (excursions to areas at risk of sand cover in the periphery of the oasis).

• Climate resources:

1. Humidity in the summer should not exceed 15-20%, which gives very good results in the treatment of most kidney diseases. Mohi Xossa Sanatorium in Bukhara is one such balneological sanatorium;
2. Healing in sunlight.

• Water resources:

1. Organizing trips along the major canals and ditches passing through the territory of the region (fishing, creating beaches, providing opportunities for water travel, water sports, etc.);
2. Rest and relaxation by the pools;

3. Study of the culture of water use of the population (educational trip to the regional Hydrological Museum);

4. Further increase the efficiency of the use of mineralized, hot springs in the region for recreational purposes;

5. Study of mineralized wells;

6. To study the possibility of using collector water in the Bukhara region for tourism and recreation purposes;

• Vegetation:

1. Excursion to the protected areas (information on the "Green Shield" of the Bukhara oasis);

2. Excursion to the landscapes of Duoba tugai and tugai around the Central Bukhara collector;

3. Identification, propagation, cultivation and sale of medicinal plants;

4. Travel to agricultural clusters.

• Fauna:

1. Acquaintance with karakul farms;

2. Travel to intensive livestock farms;

3. Organizing a trip to the Jayron nursery [2];

4. Monitoring of newly established livestock industries in the region (ostrich and quail feeding);

5. Travel to fishing farms

• Travel to economic and social facilities:

1. Travel to ancient cities (Varakhsha, Ancient (Fortress) Romitan, Zandane, etc.) [2];

2. To get acquainted with the shrines of great people of the Islamic world, 7 shrines of Bukhara (Abdukholiq Gijduvani, Khoja Arif Revgari, Mahmud Fagnavi, Khoja Ali Romitani, Boboi Samosi, Sayyid Mir Kulol, Bahauddin Naqshband);

3. Travel to the holy shrines (Khoja Zafaran, Khoja Ubbon, etc.);

4. A trip to the place where Abu Ali ibn Sina, the founder of medical science, was born and raised (Afshana). Ibn Sino Museum. Khoja Peshko Complex;

5. Study of the lifestyle of the local population [5].

It is possible to study each of the above directions separately, to organize tourist routes on it. In particular, the organization of trips along the major canals and ditches passing through the territory of the region. Due to the fact that Bukhara region is located in the desert zone, the importance of water resources is incomparable. There are great opportunities for the organization of tourist and recreational activities around water bodies (canals and ditches, artificial lakes, reservoirs) in the region [2]. The water bodies can be used for tourism, boating, fishing, and health promotion. In this regard, the Amu-Bukhara car canal and its networks are of particular importance [1].



Our research shows that the Amu-Bukhara car canal (ABMK) has the following recreational and tourist opportunities:

- Organization of educational tours around ABMK (travel tourism);
- Canal fishing;
- Rest and health in the areas around the canal;
- Development of water sports;
- Beach tourism;
- Swimming in a boat;
- Enjoyment of tugai flora and fauna;
- Knowledge of the economic importance of ABMK;
- Improving environmental culture (water economy culture);
- Exploring the ecotourism potential of ABMC, etc.

There are also great prospects for the use of Bukhara region's climate, mineralized wells and springs, as well as areas with medicinal salt and mud as a recreational resource [1].

In short, Bukhara region has great tourist potential. Although the region is located in the desert zone, it is possible to organize tourist facilities and routes on the basis of each component of nature. Currently, some of them are used in tourism, especially domestic tourism. However, in the future there is an opportunity to use these facilities as an object of international tourism by improving the tourist infrastructure. To do this, first of all, it is necessary to increase the number of media outlets informing vacationers about these tourist facilities, as well as to develop advertising, propaganda and propaganda work. In addition, further improvement of the tourist infrastructure (construction of hotels, hostels, catering and service facilities) in such places in the near future will serve to increase the flow of tourists.

## REFERENCES

1. MavlonovAhmadjonMuhamadovich, JalilovaCharosZarifovna. *Geographical aspects of use of recreation resources for tourism (on the example of Bukhara region). The Issue Contains: Proceedings of the 8<sup>th</sup> International Scientific and Practical Conference scienceandpractice:implementationtomodern society. Manchester, Great Britain. 2020. -P. 1081-1084.*
2. MavlonovAhmadjonMuhamadovich, MirzoevaIstatElmurodovna, KalandarovaDilobarDavronovna. *The Desert Tourism And Opportunities For Its Development (On The Example Of Bukhara Region). The American Journal of Interdisciplinary Innovations and Research. Article Published :27 December 2020 | Articles | Pages- 68-73.*
3. MavlonovAhmadjonMuhamadovich, NematovAhvarNusratovich. *Theinfluence of the Zarafshanriver on the development of cities. – Москва, Экономика и социум. №11(78) 2020.– С. 228-231. www.iupr.ru*
4. Кусков А.С., Голубева В.Л., Одинцова Т.Н. *Рекреационная география. – Саратов, Саратовский государственный технический университет, 2004.*
5. Мавлонов А.М., Нематов А.Н., Шарафутдинова Р.И., Каландарова Д.Д. *Географические особенности организации населенных пунктов в пустынных районах (на примере Бухарской области Республики Узбекистан).–Ашхабад, Проблемы освоения пустынь. №3-4 2020.–С. 10-13.*
6. Максаковский В.П. *Географическая картина мира. Кн. I: Общая характеристика мира. – Москва, Дрофа, 2008, 4-е изд., 495 стр.*



# AN ANALYSIS OF SERVANT LEADERSHIP IN AFRICA USING A SINGLE CASE OF THE LATE PRESIDENT DR. JOHN POMBE JOSEPH MAGUFULI IN TANZANIA

<sup>1</sup>Stephen James , <sup>2</sup>Dr. Faustine Kashumba

<sup>1</sup>Institute of Rural Development Planning, Dodoma

<sup>2</sup>The University of Dodoma Institute of Development Studies

## ABSTRACT

*“I am just a servant and I have made sacrifice of my life for giving service to Tanzanian people”. These were words spoken by the late Dr. Magufuli before the audience during his state tours in some parts of the country. The objective of this paper was to analyze servant leadership behaviours exhibited by Dr. Magufuli to increase better understanding of his servanthood. A qualitative single-case-study was a research design employed by the paper. Methods of data collection included indirect observation of audio-visual pictures and document analysis published on-line. Data analysis was conducted through content analysis in which themes were developed and categorized under various types of servant leadership behaviours based on scholars’ framework of servant leader behaviours. The paper found that Dr. Magufuli exhibited the highest level of servant leadership behaviours and among them were his ability to conceptualize vision of industrialization and taking efforts to solve the country’s complex problems in areas of road improvement and reducing energy crisis by starting construction of Hydro-Power Dam Project over Rufiji River basin. The paper further found that Dr. Magufuli healed emotional turmoil among his people especially when he succeeded to minimize corruption, drug trafficking and overcoming elephant poaching in National Parks and Game Reserves. Dr. Magufuli’s servant leadership behaviours were further expressed in his commitment to followers’ growth and success through fee-free education and expansion of Students’ Loan budget for increasing access to higher education for his people to succeed in their professional aspiration achievement. It was also found that Dr. Magufuli displayed the highest level of organizational stewardship behaviour by ensuring that government revenue, minerals, lands and water resources were safeguarded for collective interests of Tanzanian people. Based on Dr. Magufuli’s servant leadership behaviours, the paper provided recommendations for raising servant leadership among government leaders for rapid social and economic transformation of Tanzania.*

**KEY WORDS:** *Conceptualization, Emotional Healing, Organizational Stewardship*

## 1.0. INTRODUCTION

Servant Leadership (SL) in the state leadership is relevant for helping African countries realize social and economic transformations (Nwagbara, 2012; Tshiyoyo, 2012). Organizations where leaders deploy (SL) normally have citizens who are healthier, peaceful and grow faster than those with no servant leadership (Ishola, 2018). Servant Leadership among African state leaders is beneficial because it would lead to followers’ trust in their leaders, develop organizational citizenship, altruistic behaviour and satisfaction (Najam & Mustamil, 2020; Zubairu, 2019).

In spite of its abundant natural and human resources African continent has continued to be poor as a result of lack of effective leadership such as servant leadership (Craig, 2017; Dibie & Dibie, 2017). Many writers as put by Walt (2019) have revealed that African malaise such as conflicts, civil war and poverty in many African countries such as

Liberia, Central African Republic, Congo and South Sudan are in place because of leadership crisis. Corruption such as the scandal in which the former South African President Jacob Zuma was found guilty by court of using state funds to upgrade his private Nkandla residence (BONGOTIMES TV, 2016), was a result of lack of servant leadership. Servant leadership adoption among African leaders for that matter would act as a lasting solution to social, political and economic challenges facing African countries.

Pioneer scholar who introduced the concept of servant leadership as the most best leadership for organizational performance was Robert K. Greenleaf in 1970 (Boyum, 2008; Kantharia, 2011). Greenleaf expressed the meaning of servant leadership as he said: “the servant leader is servant first. It begins with natural feeling that one wants to serve, to serve first. Then conscious choice brings one to aspire to lead. That person is sharply different from one who is





leader first, perhaps because of the need to assuage an unusual power drive or acquire material possessions” (Greenleaf, 1970). Based on this idea of Greenleaf, servant leaders usually aspire to serve the needs and welfare of those they lead while sacrificing their personal and companions’ material accumulation ambition. In other words, (SL) is a form of leadership that is deep rooted in the desire of leaders to listen, identify and attend followers’ needs, keeping them a priority ahead of personal interests (Mutia & Muthamia, 2016). Notions of service, selflessness and positive intentions for followers are concepts related to servant leadership (Barbuto & Wheeler, 2006). Despite being primarily a soft approach to leadership, it is helpful in preventing ethics scandals among public and private leaders and turns them into moral and ethical servants of the people (Minnis & Callahan, 2010).

In this regard, one among of the fewest political leaders in Tanzania who declared himself as a servant was the late President Dr. John Pombe Joseph Magufuli. Born in Chato rural district, Northwest Tanzania, he was elected President of the United Republic of Tanzania for the first time in October, 2015 and re-elected for presidency in October, 2020. His demise on 17th, March, 2021 before completing his second term of office in 2025 terminated his commitment to service and sacrifice of his personal interests for the well-being of Tanzanian people. However, his servant leadership declared by himself has not been rigorously analyzed in terms of servant leadership behaviours displayed during his presidency. In addition, there has been dearth of publications on state and political leadership styles being published by the academia in Tanzania. Therefore, this paper intends to analyze Dr. John Pombe Joseph Magufuli’s servant leadership behaviours to increase better understanding of his leadership and provide recommendations for

grooming servant leadership behaviours among government leaders in Tanzania.

## 2.0. METHODS

The paper used a qualitative single-case research design in which a single subject usually becomes a research target in qualitative papers (Nock *et al.*, 2007). Methods of data collection used to analyze servant leadership behaviours displayed by the former President Dr. Magufuli consisted of indirect observation and document analysis. The author conducted systematic indirect observation of audio-visual pictures on Dr. Magufuli’s speeches and commentaries on his leadership. Audiovisual pictures that were recorded and uploaded on you tube social media by television media institutions were retrieved, stored and indirectly observed to determine the kind of behaviours that fall under servant leadership behaviours as displayed by the researched subject.

Document analysis was used in addition to indirect observation by searching on-line published news by Press institutions on Google internet application. On-line published news were also retrieved, stored and read thoroughly to obtain data which reflect servant leadership behaviours of Dr. Magufuli. Content analysis was used to coin information and establish behavioural themes which expressed various servant leadership behaviours such as conceptualization, emotional healing, helping followers to grow and succeed as well as organizational stewardship given as framework by scholars on Table 1. Data on servant leadership behaviours displayed by Dr. Magufuli’s leadership were presented in a form of textual description, documentary quotations with discussion held concurrently.

**Table 1: Scholars’ Description of Servant Leadership Behaviour Framework**

Variables	Description	Author(s) and Years
(1). Conceptualization	Leader’s ability to set vision, purpose of the organization and solve complex organizational problems	(Barbuto & Wheeler, 2006)
(2). Emotional Healing	Leader’s ability to develop concerns on followers’ feeling turmoil, emotion hurts, broken spirits and address followers’ well-being which in turn increase organizational commitment	(Jit <i>et al.</i> , 2017; Spears, 2010)
(3) Helping Followers Grow and Succeed	Refers to behaviours in which a leader knows followers’ professional or personal goals and provide support which become a long term strategy for	(Keith, 2013)





Variables	Description	Author(s) and Years
(4).Organizational Stewardship	success in increasing their professional and productive capacity It is understood from two perspectives, whereby the first conceives it as the extent to which a leader make positive contribution to the community and society as a form of social responsibility	(Barbuto & Wheeler, 2006)
	Secondly, organizational stewardship refers to the behaviour of managing organization's asset being entrusted in one's care responsibly and ultimately increase successful organizational performance	(Marsiglia, 2009)

#### 4.0. FINDINGS AND DISCUSSION

##### 4.1. Conceptualization of Vision, Government Purpose and Solving Complex Problems

The first and foremost servant leadership behaviour displayed by Dr. Magufuli was his ability in conceptualization of the desired vision, purpose of his government and solving complex country's problems as suggested in the servant leadership framework above. In this regard, the late President Dr. Magufuli expressed his vision when he took presidential office in 2015. His vision was to turn Tanzania into a country whose economic growth should depend on industrialization. A Dailynews Reporter (2021) has written Dr. Magufuli's vision of industrialization: "Dr. Magufuli's vision was to establish industries so as to set a road map for both economic growth and employment opportunities across the country, then improves household income, processing raw material and create manufacturing led growth. Thus, President Dr. Magufuli's vision on pushing for industrialization focused on changing the country's economy."

His vision was to transform the country from agrarian to industrial based economy. He had learnt that small scale agricultural economy predominant at the time when he entered the office was not sufficient to create more employment, household incomes and taxes but had persisted the raw material export economy which could not allow inflow of huge foreign currency. He was emphasizing that Tanzanian people should build processing and manufacturing industries because they would serve their needs like creation of employment opportunities and decreasing dependence on imported manufactured goods. During

his leadership, Dr. Magufuli persuaded each region and district to make allocation of lands for industrial investments and at the same time emphasizing adoption of protectionism to protect new industries against foreign competition while reducing tariffs on import of industrial spare parts. As a servant, he believed that the achievement in the vision of industrialization would put his people at similar pace of economic development enjoyed by industry led growth countries such as India, China, Malaysia, Republic of Korea, Vietnam, Brazil and Thailand.

He had pointed out that during the 1980's and early 90's, the government of Tanzania privatized many of its industries to private sector. But to him there were some private investors who bought industries from the government during the period of privatization and had failed to operate them. He was worried that such investors were a threat to the achievement of the vision of industrialization. Because of the strong desire to make an industrial Tanzania, his government planned to redistribute all non-productive private industries to other investors with capital to re-run production. These were efforts of conceptualizing the vision of industrialization and recognizing the obstacles towards its success.

He was indirectly observed speaking in several occasions that Tanzania had abundant of natural resources like livestock, forests, minerals and tourist attractions but full utilization of these resources was impossible unless Tanzania became an industrial nation. Although he died before full achievement of his vision, he succeeded to establish a total of 8,000 industries in different parts of Tanzania. Dr. Magufuli's conceptualization of the vision of industrialization in Tanzania as a whole was



similar to the one previously held by Julius Kambarage Nyerere, the founding father and first President of Tanzania being identified as a servant leader in the post-independence Tanzania (Mulinge, 2021). Dr. Magufuli's conceptualized vision of industrialization in Tanzania was an effort to revive Nyerere's vision on industrializing Tanzania for achieving rapid economic development needed by people (TBCOnline, 2019).

Apart from showing his ability to conceptualize the vision of industrialization as per servant leadership framework, President Dr. Magufuli also succeeded to express the purpose of his government in the first term of office. Indirect observation from his inaugural speech to the 11<sup>th</sup> Parliament after the election of 2015 revealed numerous purposes as being: (1) To provide government service to all people of Tanzania regardless of their political partisanship, (2) Use his government leadership to protect the national resources such as country borders, minerals, water, land, forests and air space for the benefits of all, (3) Strengthen unity, peace, stability and ensure consolidation of the Union between Tanzania Mainland and Zanzibar as well as protecting the legitimate existence of Zanzibar Revolutionary Government, (4) Strengthen organs of the government by providing adequate financing to the executive, judiciary and parliament to facilitate the performance of their functions for his followers, (5) Fight against poverty, inequality and unemployment and (6) Improve provision of health services by ensuring that each village has a dispensary, health centers in every ward, hospital in each district and construct referral hospitals in every administrative region of Tanzania. Keen examination of Dr. Magufuli's leadership purposes portrayed a commitment to address the needs of his people and among them being provision of services without discrimination, protection of natural resources, living in peace and security as well as consolidating the union between Zanzibar and Tanzania Mainland.

Other purposes noted from indirect observation of Dr. Magufuli's speech delivered were: (7) Improving the quality of education at all levels for the kids and youth, (11) Increase access to clean water by 85% in rural areas and 95% in urban areas, (12) Provide adequate electricity to rural and urban areas of Tanzania, (13) Create small cabinet Ministers to avoid over financing of government Ministries and (14) To strengthen international cooperation by increasing Tanzania's participation in East African Community (EAC), Southern African Development Community (SADC), African Development Bank (AfDB), African Union, and foster economic diplomatic relations with foreign countries so that his people benefit by acquiring investment and overseas markets of which they needed for their economic well-being.

Further ability in conceptualization as a servant leader was revealed in solving organizational complex problems such as unimproved roads with its associated traffic congestion especially in the city of Dar es Salaam. He took necessary measures to improve physical infrastructure to expand smooth transportation as Al Jazeera television (2019) wrote: "construction of numerous highways and improvement of thousands of feeder roads in areas has been undertaken. The country's first electric railway and restoration of railway transport broken-up for many years took place under Dr. Magufuli's leadership. He is credited for revival of the national carrier, Air Tanzania."

After becoming a president, his government succeeded in construction of the Kijazi Ubungo interchange flyover, Tazara Intersection (Mfugale Flyover) on Julius Nyerere Airport road, the Kimara-Kibaha Highway in Dar es Salaam and Selander Bridge for total costs of at least 765.622 billion Tanzanian shillings (Blog, 2018; TANROADS, 2018; Tanzania Invest.com, 2021). His inception of public road and bridges construction with solar lighting eventually reduced motor vehicle congestion which helped his followers spend less time during their commuting to-and-from work (Maximillan, 2019; Mpogole & Msangi, 2016). Dr. Magufuli's infrastructural development in the city of Da es Salam and other areas in Tanzania was similar behaviour of servant leaders such as Babatunde Raji Fashola whom through servanthood as a governor of Lagos solicited funds to solve the problem of roads by implementing major road works, lighting and drainage systems to smoothen transport of the people of Lagos in Nigeria (Ekundayo, 2013). Modernization of roads by servants such as Babatunde and Dr. Magufuli was based on their belief that their people needed modern transport for easier movement of their goods to the markets for earning income to enhance their living standards.

Dr. Magufuli further restored the railway transport which had stopped for many years from Dar es Salaam to Kilimanjaro and Arusha. Restoration of the respective railway transport was his ability as a servant to recognize that it could facilitate cheap transport of goods and services of which were needed by his people. In addition, Dr. Magufuli introduced a major project of electric Standard Gauge Railway (SGR) construction from Dar es Salaam via Morogoro to Dodoma. The project started with no dependence on foreign aid and expected to cost a total of 6.05 trillion Tanzanian shillings (Bongo Sihami, 2020). Other railway construction projects such as the Isaka to Mwanza line were underway to take off during his demise on 17<sup>th</sup>, March, 2021.

All these projects were intended to modernize the rail roads and provide efficient cheap transport services highly awaited by his people almost for fifty five years after independence. Immediately after



taking oath as a President, Dr. Magufuli government used a total of 1.8 trillion Tanzanian shillings in buying 8 aircrafts which restored flight services domestically and internationally in destinations such as China, India, Zimbabwe and Zambia. This was one of dramatic achievement and remains a paradox of where Dr. Magufuli obtained such huge amount of money to purchase 8 aircrafts for national carrier within a short period of time in office. His government took extra efforts of rehabilitating and expanding many airports around the country. A new plan to construct Msalato International Airport in Dodoma capital city was also under way before his passing away in March, 2021. Dr Magufuli's ability in the physical infrastructure development within a short period of time revealed the extent to which he had decided to serve his people with modern and efficient transport services.

Importantly, Dr. Magufuli conceptualized the energy crisis as a complex problem facing his people for 54 years after independence. In one you tube speech reported by Lymo Media (2017), the late President Dr. Magufuli was observed saying that compared to Ethiopia which was expecting to spend 17,000 megawatts of electricity by 2020, Tanzania was still lagging behind with only 1,450 megawatts. He knew that the people of Tanzania needed cheap electricity but circumstance indicated well that Tanzania's electricity was inadequate and expensive for industry and domestic use. Being aware of electricity as a complex problem, Dr. Magufuli's servant leadership started construction of Stiegler's Hydro Power Dam Project which was going to cost a total of 2.9 billion US dollars (4 trillion Tanzanian Shillings) with less donor dependence. The project intention was to provide a total of 2,115 megawatts of power to ensure that adequate supply of energy for industry, farming, service sectors and domestic use was available during his leadership. He was also determined to use other sources of energy such as coal, gas, geothermal sources and winds to increase energy supply to reduce prices of energy for industrial and domestic use. He was taking these initiatives to respond to reliable and cheap energy needs among his people.

#### 4.2. Dr. Magufuli's Emotional Healing

Further servant leadership behaviour employed by Dr. Magufuli apart from conceptualization was his ability in emotional healing of his people. Prior to healing the emotions, Dr. Magufuli identified the most emotional hurting factors as he took leadership in 2015. Some of the emotional ills were explained in his first speech delivered to 11<sup>th</sup> Parliament when he was indirectly observed on you tube saying that the people of Tanzania were emotionally unhappy of: (1) Corruption, theft, laziness and revenue embezzlement in government agencies and work stations, (2)

Shortage of clean water supply, (3) Elephant poaching, (4) Drug trafficking and abuse, (5) Poor health services and depersonalization behaviour of health workers and (9) Lack of farming inputs for farmers.

He employed vivid actions to fight against corruption, theft and financial embezzlement to bring back the followers' happiness. In 2016 as an example, Magufuli's government enacted The Economic and Organized Crimes Control Act, Cap.200 forming the High Court for Corruption and Economic Crimes Division to deal against corruption and economic sabotage crimes (United Republic of Tanzania, 2016). He appealed to Prevention and Combating Corruption Bureau, Police Force and the Attorney General's office to collaborate and refrain from unethical behaviour in the fight against corruption. Dr. Magufuli's struggle against corruption started from the fact that he was aware of corruption being a major barrier for rapid social and economic transformation of his people and the country in general.

He made several tours in government offices such as Tanzania Revenue Authority (TRA), Bank of Tanzania (BOT), Weighbridge stations, Tanzania Ports Authority and Ministries explaining that embezzlement, petty and grand corruption were intolerable matters of criminal offence. He dismissed government leaders and managers who were suspected of serving their personal interests through corruption. Although, Andriani (2017) believed that his approach of anti-corruption was authoritarian, it wasn't easy for him to behave mercifully based on higher level of corruption existing in the country at a time he took government leadership. Dr. Magufuli's efforts in the fight against corruption as one of the worst emotional hurt led to citizens' perception that corruption level in Tanzania had fallen during his presidency (Rahman, 2019).

Apart from fighting corruption, Dr. Magufuli's leadership ensured that the water shortage which was emotionally hurting was resolved by embarking on 1,268 and 155 water projects in rural and urban areas of which increased accessibility to clean water in rural areas from 47% in 2015 to 70% in 2020 and in urban areas rising from 74% to 84% in 2020 (Daily News, 2020). He expressed his commitment to use the water resources such as Lake Victoria to supply adequate water in Nzega, Tabora, and Igunga districts as areas with little rainfalls by using domestic revenue raised by his leadership. By doing this Dr. Magufuli was practically implementing the appeal from Nnamdi Azikiwe, a former Nigerian President who often advised African leaders to become servants by using natural resources of their countries to meet people's expectations of leadership (Nwagbara, 2012). With such behaviours it was clear that servants like Azikiwe and Dr. Magufuli had



strong urge in using natural resources such as water to meet citizens' needs rather than of their own.

Dr. Magufuli's service did not stop at clean water supply improvement but also was extended to anti-elephant poaching in National Parks and Game Reserves. Immediately he turned to serious anti-elephant poaching efforts. Before his efforts against elephant poaching for ivory, Tanzania became a leading country in the world for losing more elephants to poaching; and one wildlife census revealed that the country's elephant population had diminished from 110,000 in 2009 to barely 43,000 by 2014 (Reuters Staff, 2019; Russo, 2014). This was at least 60.9% of elephants being lost in poaching from which ivories were exported illegally to destinations in China and Vietnam for ornament and medicine production. Dr. Magufuli's leadership introduced community participation in elephant protection and firmly ordered the security forces including the Tanzania National and Transnational Serious Crimes Investigation Unit (NTSCIU) to fight by all means against elephant poachers regardless of their position, age, religion, popularity and nationality (Reuters Staff, 2016).

Following his vigorous efforts against elephant poaching, the security forces arrested the "Ivory Queen", a Chinese business woman who was one among the illegal ivory exporters. She was convicted by court with other two men for 15 years jail for having killed 400 elephants worth of \$ 2.5 million between 2000 and 2014 (BBC News, 2019). Dr. Magufuli's anti-poaching efforts eventually rebound the elephant population from 43,000 in 2014 to 60,000 by July, 2019 and poaching was no longer heard on television and radio news (Phiri, 2020). These efforts were greatest exhibition of servant leadership because he learnt that people didn't like poaching and therefore all his efforts were taken to overcome elephant poaching to bring back trust in leadership.

Dr. Magufuli's servanthood was further expressed in the fight against illicit drug trafficking and abuse as among of the worst problems which were causing emotional turmoil in his people. Before coming to office, drug trafficking and abuse became a national catastrophe contributing to distortion of youth cognition and social behaviours (Possi, 1996). Sources of illicit drug supply were countries like Pakistan, India and Bangladesh while the lack of political will against illicit drugs, corruption and involvement of high ranking government officials were some of the factors which led to strengthening of this illegal business (Mekere, 2014).

Immediately after assuming power as President, Dr. Magufuli's government enacted Drug Control and Enforcement Act, No. 5 of 2015 (URT, 2015); to heal his people's emotional disorders resulting from drug trafficking and abuse. The law established the Drug Control and Enforcement

Authority of which among many functions it controlled drug trafficking and drug abuse through arresting, search, seizure, investigation, provision of public education and carrying out court proceedings. Eventually, Tanzania became one of the few African countries in minimizing drug trafficking and drug abuse considerably. Because of the victory in the fight against drug trafficking, other countries like Uganda, Mozambique, Nigeria and Ghana were requesting to learn government techniques that had been used in overcoming drug trafficking and abuse (Xinhuanet, 2020).

Dr. Magufuli further responded by improving quality of health services. His leadership took a number of measures including: employment of more health workers from 86,152 in 2015 to 100,631 by 2020 and constructed 1,198 Clinics, 487 Health Centres, 71 District Hopsitals, 10 Regional Referral Hopsitals including the Mwalimu Nyerere Memorial Hospital which had not been completed since 1970's. His leadership increased essential medical equipment budget from 31 billion Tanzania shillings to 270 billion shillings of which increased availability of drugs in health facilities by June, 2020 (Dr. Magufuli, 2020). His measures to improve quality of health services in terms of shortening distances of health facilities in urban and rural areas, increasing availability of health care staff and making improvement in the availability of essential drugs for his people was a significant step in healing feelings over health services. He knew well that quality improvement of health services will grant good health for people to maintain their labour power for socio-economic development.

Dr. Magufuli's servant leadership was also expressed by ensuring that farmers were receiving adequate farming inputs timely without delays. His leadership launched Agricultural Sector Development Programme II worth of 13 trillion Tanzanian shillings of which among other priorities it was intending to distribute quality seeds to revamp production (FAO, 2018). He often put an emphasis that farmers should receive farming inputs as efficiently as possible while protecting them not to sell their crops like cashew nuts, maize and coffee at lower prices. Dr. Magufuli wanted to develop a more modern agricultural sector that is productive by insisting the private sector and cooperatives to establish agro-processing industries to process farmers' crops for value addition (Admin, 2021).

### **4.3. His Ability in Helping Followers to Grow and Succeed**

The late Dr. Magufuli did not only have ability in healing emotions of his people in employing servant leadership but also he was helping his followers to grow and succeed. Helping followers' to grow and succeed refers to the support Dr. Magufuli's servant leadership provided to his





people to acquire professional and productive capacity in terms of improving skills, knowledge, values and attitudes. In giving support to his people to grow and succeed, his government leadership introduced a fee-free basic education since 2016 as Sumra and Haki Elimu (2017) wrote: “the government of Tanzania is implementing the Education and Training Policy of 2014 in which it is committed to provision of fee free education. This replaced the former basic education financing system where the government contributed part of running cost and the rest were contributed through fees and parent contribution.”

Dr. Magufuli’s acceptance to implement a policy on fee-free education in Public Primary and Lower Secondary Schools was a realization of weaknesses in the former system where parents’ contribution in terms of school fee denied opportunity to education among kids living in poor families. He implemented this policy to show high levels of servanthood by giving support to the kids and youth of Tanzania to get education for growing skills and productive capacity. By January, 2016 his government was disbursing a total of 18.77 billion shillings to finance fee-free education in Public Primary and Secondary Schools and at the same time solving the desks shortage especially in Primary schools (Radio Vaticana, 2017). The paper suggests that the fee-free education implemented by Dr. Magufuli’s leadership was an attempt to reverse practices to Mahatma Gandhi and Julius Kambarage Nyerere being servant leaders who advocated provision of free education in India and Tanzania (Garzilli, 2003; Gichuki, 2014; Mbawala, 2017; Tandon, 2018). These servant leaders put an emphasis on fee-free education because they were aware that education was a human right for every person but could not be afforded by all individuals without being fee-free education under absolute government support.

Apart from implementing a fee-free education to enhance skills of the kids and youth in Tanzania, Dr. Magufuli’s leadership did a lot in improving higher education students’ welfare including construction of dormitories, libraries, lecture theatres and cafeteria to ensure that students in several public higher educational institutions had conducive learning environment as they strove towards achievement of professional aspirations. His servanthood will continue to be reckoned for increasing higher education students’ loan to provide more access to tertiary education (Daily News, 2021). A total of 464 billion Tanzanian shillings in 2020/21 was provided which in turn increased beneficiaries from 93,100 students in 2014/15 to 145,000 in 2020/21 (Nakkazi, 2021). His leadership also increased loan recovery from beneficiaries to uplift the capacity of Higher Education Students’ Loan Board in possession of more funds to deliver

service to more youth to gain education. Dr. Magufuli’s support to higher education was based on the beliefs that once many of his people had achieved a profession from higher education they would seek formal and informal employment which they needed to improve their living.

#### 4.4. Dr. Magufuli’s Organizational Stewardship Behaviour

Apart from supporting his people to grow in terms of skills and productive capacity through education initiatives, Dr. Magufuli displayed organizational stewardship behaviour. It has been indirectly observed on YouTube video speech that Dr. Magufuli’s government donated tons of maize, blankets, medicines, mosquito nets and tents to the people of Zimbabwe after a deadly storm “idai” which submerged houses, destroyed infrastructures and lives in Mozambique, Malawi and Zimbabwe in the early, March, 2019 (BUKOB TV ONLINE, 2019, 2021). An attempt to provide aid to people of Zimbabwe after the weather problem was a significant exhibition of servanthood at African sub-continental level. He usually felt that despite of being committed to improving lives of his people in Tanzania, he was socially responsible for other African countries like he did for Zimbabwe. In this way, Dr. Magufuli was partly acting like Julius Kambarage Nyerere, a servant leader whose leadership implemented social responsibility by providing resources to help the struggle for independence in Namibia, Zimbabwe, Angola, Mozambique and anti-apartheid struggles in South Africa during the 1980’s (SAHO, 2019). These behaviours displayed by Nyerere and Dr. Magufuli became a base from which to understand that servants feel socially responsible for other community of states rather than remaining parochial in service provision.

Organizational stewardship behaviour of the late President Dr. Magufuli as a servant was further expressed in safeguarding the country’s revenue for national prosperity. He learnt firstly that the country was losing a lot of revenue through tax evasion and so he made it clear that he will deal against tax evasion as Reuters Staff (2017) wrote: “Dr. Magufuli vowed to toughen up a crackdown on tax evasion by big businesses to boost domestic revenues. He ordered courts to enforce payments of tax claims worth than 7.5 trillion Tanzanian shillings from big firms. Dr. Magufuli sacked dozens of senior public officials.”

In his efforts against tax evasion from which the government lost revenue, Dr. Magufuli for example pointed out that the big Multinational Companies conducting mining operations were among of the big businesses which were not paying tax adequately and suspected them of committing



fraud over the quantity of minerals and export of mineral sands. He urged the courts, Tanzania Revenue Authority (TRA) and Ministers from responsible ministries to ensure that businesses such as those in the mining sector were respecting business ethics by paying tax and conducting their operations honestly and transparently to raise domestic revenues (Shiyo, 2017).

Following his suspicion over tax evasion and fraud among big mining companies, he appointed two Presidential Committees to probe into mining operations of one Canadian Company. The first Presidential Committee was established between March and April, 2017 to probe into the quantity of minerals existing in the exported mineral sands by respective company. As a result of committee investigation by 24<sup>th</sup>, May, 2017, the sands had an average of 1,400 grams of gold per ton of mineral sand which was more than 200 grams being reported by the Tanzania Minerals Audit Agency at that time. Furthermore, the Committee reported disparity existence of copper, silver, iron, sulphur, iridium, rhodium and lithium (Shiyo, 2017); of which were not declared by foreign mining company during export of the mineral sands.

The second Presidential Committee was formed immediately for comparison of results and handed the report to Dr. Magufuli on 12<sup>th</sup>, June, 2017. Its report was similar to the first committee and alleged the company for having exported between 44,277 and 61,320 containers of mineral sands between 1998 and 2017. It was also reported that the respective Mining Company had failed to pay 95.5 trillion shillings income tax, 94.4 billion shillings in withholding tax, failed to pay 11.1 trillion shillings in mining royalty and 1.6 trillion shillings in taxes form under declared shipping fees. Following the two reports of Presidential Committees, Dr. Magufuli's expression of organizational stewardship behaviour was felt when his leadership ordered the Canadian Gold Mining Company to pay \$190 billion as tax arrears and government royalties in July, 2017. But the discussion of good faith between Dr. Magufuli's government and the company higher management resolved to pay a total of \$300 million in October, 2017 (ITR, 2017). All these measures displayed highest level of organizational stewardship by ensuring that the lost financial resources through tax evasion and dishonest in mining operations in a period of 19 years was partly repaid to the people of Tanzania. This intervention really proved that Dr. Magufuli was a servant leader determined to protect resources that were entrusted in his leadership by people of Tanzania.

His leadership also embarked on minerals legislation change for legal protection of Tanzanians' interests in the mineral resources. Legislative amendment to the Mining Act Cap 123, (Act. No. 14 of 2010) as expressed by Kapdi and Parring (2018)

was among of the greatest achievements in legal protection of Tanzanians' interests in the mineral sector showing highest level of stewardship. The amendments replaced the former 6% government royalty from companies' mineral export to 16% free government shareholding in foreign mining companies' capital. The government also gained entitlement to share ownership up to 50% in case of future preference. The Mining Commission was established and among other functions was to monitor the mining industry operations while export of the mineral sands was banned and investors required processing the mineral sands inside Tanzania.

Proceedingly, his leadership formulated The Mining (Mineral Rights) Regulations in 2020. Among other matters, the regulations required mineral companies to buy goods and services produced by indigenous companies to give a room for local content in mining operations. Mining companies were required to lodge an integrity pledge in business operations and refrain from destructive acts to the national economy or otherwise their facilities would fall under government ownership because of the lack in integrity. The mineral rights regulations also required companies to prepare an environmental management plan and corporate social responsibility in areas of mining operations. Mining licensees were also required to use insurance services provided by Tanzanian insurers, maintain operating accounts in Tanzanian banks or those which had the majority of shareholders from Tanzania (URT, 2020). With regards to employment, the Mineral Rights Regulations required companies to keep training and succession plan and impose strict requirements to employ foreigners in mining companies while junior and middle level positions had to be occupied by Tanzanian people. His leadership also had accused oil and natural gas companies for seeking high profits at the expense of nation's development (BHRRC, 2018). He was determined to do the same reforms in the oil and gas operations to ensure that the natural resources were not exploited by big businesses but extracted for mutual benefits of investors and Tanzanian people as a whole.

Impressive organizational stewardship behaviour in servanthood of Dr. Magufuli was displayed when he refused to accept the Chinese Bagamoyo Port Project Implementation due to its toxic conditions. The contract for construction of Bagamoyo Port had been signed in 2013 but Dr. Magufuli argued that the project conditions were a threat to country's interests. He was heard on you tube speech speaking that project conditions such as tax exemption, 99 years land lease contrary to national laws and prevention of the recipient country from developing other coastal ports after project completion were going to stifle country's economy



(Millard Ayo, 2019, 2021). Dr. Magufuli kept on emphasizing that the conditions brought by Chinese company over the Bagamoyo Port Project were unacceptable unless they were re-negotiated to give a win-win advantage for both parties. This was a tremendous attempt to safeguard the Indian Ocean water and coastal land strip against any form of exploitation for private interests of the minority. He did not compromise with government deals which aimed to exploit Tanzanian people revealing highest level of servanthood.

He safeguarded the government revenues by discouraging exorbitant and wasteful expenditure. He took various measures like minimizing presidential foreign travel and banning unnecessary foreign trips among government officials to save money for pertinent development desires (BBC Africa, 2019). Dr. Magufuli's behaviour in discouraging exorbitant spending portrayed similar behaviour of Thomas Sankara a former servant leader of Burkina Faso who was preventing the government from purchase of expensive cars to save money for achieving financial self-reliance (Degbotse, 2016). Furthermore, Dr. Magufuli insisted on improving health sector by buying equipment, construction of medical infrastructure and introducing more specialized health services to reduce expensive health referral abroad (Shekighenda, 2020). He slashed huge salary of top government officials who were paid \$18,000 a month to \$7,000 to reduce salary inequity and eliminate social classes of highly paid and underpaid civil servants whom he referred many were receiving \$140 per month (BBC Africa, 2016). His measures in fighting against unnecessary over spending in government organs, tax evasion and strengthening financial digital solutions such as the use of Electronic Fiscal Device Management System, Government e-Payment System and Tanzania Customs Integrated Systems all contributed to increasing revenue collection from 800 billion to over 1.3 trillion shillings per month within a short period of his leadership (Dailynews Reporter, 2021). These were dramatic achievements in organizational stewardship behaviours of a servant leader in Tanzania.

## 5. CONCLUSION

The objective of this paper was to analyze servant leadership behaviours displayed by Dr. Magufuli's leadership to provide better understanding of his servanthood. The paper found that Dr. Magufuli demonstrated high level of servant leadership behaviours. There was alignment between his words of self-declaring a servant and behaviours exhibited during his exercise of country's leadership as a president. Because of his denial of selfishness and personal accumulation of wealth for himself, Tanzania experienced rapid social and economic transformations ranging from implementation of

major projects in infrastructure such as road network, highway bridges, flyovers construction, huge Hydro Power Dam construction, electric Standard Gauge Railway Project to fee-free education in basic education. Dr. Magufuli's leadership minimized drug trafficking and armed robbery, halted elephant poaching and increased government revenues; of which all his successes originated from his servanthood in terms of conceptualization of the country's complex problems, emotional healing of his people and his organizational stewardship behaviour.

Tanzania had experience of rapid transformation under Dr. Magufuli's servanthood. The World Bank declared Tanzania as a middle lower income country in early July, 2020 of which was five years ahead of government target. If Dr. Magufuli's servant leadership had proceeded in his second term of presidency, Tanzania probably would have ascended into upper middle income country before 2025 in the East African region. The paper further acknowledges that there may be some critics directed to Dr. Magufuli's leadership among the minority. Opponents to Dr. Magufuli's leadership may be a result of the lack of experience and technical expertise over servant leadership. Sometimes servant leaders may behave in a way that annoys few individuals especially when they consider obstructions as baseless and intending to distract their commitment to serve the needs of ordinary people.

## 6. RECOMMENDATIONS AND FURTHER RESEARCH

Dr. Magufuli's servant leadership needs to be emulated by the current and future leaders of Tanzania for rapid social and economic transformations. To emulate it, the following need to be implemented:

- i. The current top, senior and junior government leaders at executive, parliament, judiciary, local government authorities and other public organizations should engage in self-learning of servant leadership and practice it in the same way as done by the late Dr. Magufuli.
- ii. Servant Leadership Development Programmes can be designed regularly for those who hold leadership positions in government sector to impart skills, knowledge, awareness and interests in becoming servant leaders for well-being of Tanzania.
- iii. Leadership Education particularly on servant leadership should be included in Education Curriculum of all levels of education in order to groom potential servant leaders in Tanzania. The current practice of leaving leadership education to





students pursuing Business and Organizational Management is not sufficient to produce servant leaders like Dr. Magufuli.

In spite of these recommendations, this paper had limitation especially in its inability to triangulate qualitative approaches with quantitative approaches in the study of servant leadership. Based on such limitation, the paper suggests that other authors can use quantitative methods like using a questionnaire which accommodates more other servant leadership behaviours to study servant leadership of the late Dr. Magufuli to make results comparison with this paper.

## REFERENCE

- Admin. (2021). *What Dr. Dr. Magufuli did in The Tanzanian Agriculture sector. – Kilimo.* <https://kilimoafrica.com/what-Dr. Dr. Magufuli-did-in-tanzanian-agriculture-sector/>
- Al Jazeera. (2019). *The complex legacy of Tanzania's John Dr. Dr. Magufuli | Tanzania News | Al Jazeera.* <https://www.aljazeera.com/features/2021/3/29/tanzania-remembering-john-dr. Dr. Magufuli's-legacy>
- Andreoni, A. (2017). *Anti-Corruption in Tanzania: A political settlements analysis.*
- Bailie Craig. (2017). *The RARE Leadership Model, Jacob Zuma and Nkandla: Thoughts on the virtues of leadership.* *Politeia*, 36(1), 1–23. <https://doi.org/10.25159/0256-8845/3095>
- Barbuto, J., John (Jay), & Wheeler, D. (2006). *Scale Development and Construct Clarification of Servant Leadership.* *Group & Organization Management - Group Organ Manage*, 31, 300–326. <https://doi.org/10.1177/1059601106287091>
- BBC Africa. (2016, March 30). *Tanzania's President Dr. Dr. Magufuli 'to slash' civil servant salaries.* *BBC News.* <https://www.bbc.com/news/world-africa-35925477>
- BBC Africa. (2019, March 5). *Five things Tanzania's President 'Bulldozer' Dr. Dr. Magufuli has banned.* *BBC News.* <https://www.bbc.com/news/world-africa-47334545>
- BBC News. (2019, February 19). *Chinese 'Ivory Queen' Yang Fenglan jailed in Tanzania.* *BBC News.* <https://www.bbc.com/news/world-africa-47294715>
- BHRC. (2018, September 10). *Tanzania: President accuses oil & gas companies of seeking huge profits at the expense of the country's development.* *Business & Human Rights Resource Centre.* <https://www.business-humanrights.org/en/latest-news/tanzania-president-accuses-oil-gas-companies-of-seeking-huge-profits-at-the-expense-of-the-countrys-development/>
- Blog, M. (2018, September 27). *MATUKIO @ MICHUZI BLOG: Rais Dr. Magufuli Azindua Flyover ya Mfugale Eneo la Tazara Jijini Dar es salaam leo.* *MATUKIO @ MICHUZI BLOG.* <https://michuzi-matukio.blogspot.com/2018/09/rais-dr. Dr. Magufuli-azindua-flyover-ya.html>
- Bongo Sihami. (2020, June 29). *Dr. Magufuli: Nilipotaka Kujenga Treni ya Umeme Inawezekana Hawakuniamini''.* <https://www.youtube.com/watch?v=bWqF7B0v5Y4>
- BONGOTIMES TV. (2016, March 31). *South African Court rules that Zuma must repay part of Nkandla home money.* <https://www.youtube.com/watch?v=XNUzOuU22qo>
- Boyum, G. (2008). *The Historical and Philosophical Influences on Greenleaf's Concept of Servant Leadership: Setting the Stage for Theory Building.* *University of Minnesota.*
- BUKOKA TV ONLINE. (2019, March 29). *Mozambique Is Struggling To Recover From Cyclone Idai (HBO).* [https://www.youtube.com/watch?v=\\_M7yJS6LVzc](https://www.youtube.com/watch?v=_M7yJS6LVzc)
- BUKOKA TV ONLINE. (2021, March 23). *Speech by Zimbabwean President Mnangagwa during the memorial service of the late president Dr. Dr. Magufuli.* [https://www.youtube.com/watch?v=\\_14mh\\_5LGI](https://www.youtube.com/watch?v=_14mh_5LGI)
- Daillynews Reporter. (2021, March 24). *Dr Dr. Dr. Magufuli's legacy in boosting domestic revenues lives on.* <https://daillynews.co.tz/news/2021-03-236059f76fa00db.aspx>
- Daily News. (2020, August 20). *Impressive headway made on water front.* <https://daillynews.co.tz/news/2020-08-205f3e31676aff0.aspx>
- Daily News. (2021, April 5). *Tanzania: Higher Learning Students Eulogise Dr. Dr. Magufuli—AllAfrica.com.* <https://allafrica.com/stories/202104050100.html>
- Daillynews Reporter. (2021, March 26). *Daillynews: Magufulifli's Vision.* <https://www.daillynews.co.tz/news/2021-03-25605cb081201f7.aspx>
- Degbotse, K. (2016). *An Analysis Of Thomas Sankara A Former President Of Burkina Faso As A Leader.*
- Dibie, R., & Dibie, J. (2017). *Analysis of the paralysis of government leadership in sub-Saharan Africa | Africa's Public Service Delivery and Performance Review.* <https://journals.co.za/doi/abs/10.4102/apsdpr.v5i1.167>
- Ekundayo, J. M. O. (2013). *Out of Africa: Fashola-Reinventing Servant Leadership to Engender Nigeria's Transformation: Foreword by Femi Falana, San. AuthorHouse.*
- FAO. (2018). *President Dr. Dr. Magufuli launches 13 trillion/- Agruculture Sector Development Programme.* <http://www.fao.org/tanzania/news/detail-events/en/c/1138127/>





24. Garzilli, B. J. (2003). *Gandhi as Guiding Star: Servant Leadership in Mediation*. <https://www.mediate.com/articles/garzilliJ1.cfm>
25. Gichuki, D. (2014). *Leadership in Africa and the Role of Youth in the Leadership Milieu*. 29.
26. Greenleaf, R. . K. (1970). *The Servant as Leader*.
27. Ishola, S. A. (2018). *Servant Leadership Model As Panacea For Growing A Healthy Church And Organization*. 8.
28. ITR. (2017). *Global Tax 50 2017: John Pombe Joseph Dr. Dr. Magufuli*. *International Tax Review*.  
<https://www.internationaltaxreview.com/article/b1f7nbjfk00gcv/global-tax-50-2017-john-pombe-joseph-Dr.-Dr.-Magufuli>
29. Jit, R., Sharma, C. S., & Kawatra, M. (2017). *Healing a Broken Spirit: Role of Servant Leadership*. 42(2), 15.
30. Kantharia, B. N. (2011). *Servant Leadership: An Imperative Leadership Style for Leader Managers*.
31. Kapdi, D.-N., & Parring, R. (2018, February). *Amendments to the Mining Act in Tanzania | Lexology*.  
<https://www.lexology.com/library/detail.aspx?g=f26f7200-ee53-4271-9560-2f9b64afb8d0>
32. Keith, M. K. (2013). *Growing to Greatness through Servant Leadership*. Article.
33. Lyimo Media. (2017, June 28). *Rais. Dr. Magufuli Aazimia Kujenga Bwawa Kubwa la Kuzalisha Umeme*.  
<https://www.youtube.com/watch?v=5LxGZB399YI>
34. Dr. Magufuli, J. P. (2020). *Hotuba ya Mhe. Dkt. John Pombe Joseph Dr. Magufuli, Rais wa Jamhuri ya Muungano wa Tanzania Wakati wa Kulihutubia kwa mara ya Mwisho Bunge la Kumi na moja la Jamhuri ya Muungano wa Tanzania, Ukumbi wa Bunge, Dodoma, Tarehe 16 Juni, 2020*. 96.
35. Marsiglia, A. J. (2009). *Comparison of Servant Leadership and Stewardship*. 10.
36. Maximillan, S. (2019, December). *C40: Improvement of the Tazara Intersection (Mfugale Flyover)*. C40.  
[https://www.c40cities.org/case\\_studies/improvement-of-the-tazara-intersection-mfugale-flyover](https://www.c40cities.org/case_studies/improvement-of-the-tazara-intersection-mfugale-flyover)
37. Mbawala, M. B. (2017). *An Assessment of the Implementation of fee free Basic education in Tanzania: A Case of Ruangwa District Council, Lindi Region*. 85.
38. Mekere, J. J. (2014). *Illicit Drug Trafficking and its Negative Impacts on Youths: A Case Study of Kinondoni and Temeke Districts in Dar es salaam*. 119.
39. Millard Ayo. (2019, June 10). *President Dr. Dr. Magufuli reject Chinese Project, To take the Land for 99 years?*  
[https://www.youtube.com/watch?v=lg2a1q\\_aApI](https://www.youtube.com/watch?v=lg2a1q_aApI)
40. Millard Ayo. (2021, April 11). *Dr. Dr. Magufuli On The Chinese Bagamoyo Port Project (English Speech)*.  
<https://www.youtube.com/watch?v=197IARUvZ9s>
41. Minnis, S., & Callahan, J. (2010). *Servant Leadership in Question: A Critical Review of Power within Servant Leadership*.
42. Mpogole, H., & Msangi, S. (2016). *Traffic Congestion in Dar es Salaam: Implications for Workers' Productivity*. *Journal of Sustainable Development*, 9(6), 103.  
<https://doi.org/10.5539/jsd.v9n6p103>
43. Mulinge, P. (2021). *The Anchor of Servant Leadership: Julius Nyerere and the Virtue of Humility in Mathew. P, Song, J, Fedrch.S.R and Spears .L.C. Wisdom, LOve and Legitimate Power in the Age of Chaos*.  
[https://books.google.co.tz/books?hl=en&lr=&id=ATQGEAAAQBAJ&oi=fnd&pg=PA91&dq=servant+leadership++in+african+continent&ots=Jv7zMLLXUS&sig=nvnpkya7OFyLrCRKriZq2hKB4cs&redir\\_esc=y#v=onepage&q=servant%20leadership%20in%20african%20continent&f=false](https://books.google.co.tz/books?hl=en&lr=&id=ATQGEAAAQBAJ&oi=fnd&pg=PA91&dq=servant+leadership++in+african+continent&ots=Jv7zMLLXUS&sig=nvnpkya7OFyLrCRKriZq2hKB4cs&redir_esc=y#v=onepage&q=servant%20leadership%20in%20african%20continent&f=false)
44. Mutia, P. M., & Muthamia, S. (2016). *The Dichotomy of Servant Leadership and Its practicality on the African Continent*. 05, 16.
45. Najam, U., & Mustamil, N. (2020). *Servant Leadership: A bibliometric Review*. *International Journal of Organizational Leadership*, 9(3), 138–155. <https://doi.org/10.33844/ijol.2020.60501>
46. Nakkazi, E. (2021, April 15). *Dr. Dr. Magufuli used loan system to open tertiary access*.  
<https://www.universityworldnews.com/post.php?story=20210413142208739>
47. Nock, M. K., Michel, B. D., & Photos, V. I. (2007). *Single-case Research Designs*. 14.
48. Nwagbara, U. (2012). *Sustaining Development through Servant-Leadership: A Commentary on Nnamdi Azikiwe's My Odyssey: An Autobiography (1970)*. *Journal of Sustainable Development in Africa*, Volume 13, No.5, 5.
49. Phiri, E. D. G. (2020, January 24). *Tanzania's anti-poaching success offers valuable lessons for other African countries*. ENACT Africa.  
<https://enactafrica.org/research/trend-reports/tanzanias-anti-poaching-success-offers-valuable-lessons-for-other-african-countries>
50. Possi, M. K. (1996). *Effects of Drug Abuse on Cognitive and Social Behaviours: A Potential Problem Among Youth In Tanzania*. 19.
51. Radio Vaticana. (2017). *Mafanikio yaliyopatikana hadi sasa chini ya Rais John Dr. Dr. Magufuli*.  
[http://www.archivioradiovaticana.va/storico/2017/12/18/mafanikio\\_yaliyopatikana\\_hadi\\_sasa\\_chini\\_ya\\_rais\\_john\\_Dr.\\_Dr.\\_Magufuli/sw-1355394](http://www.archivioradiovaticana.va/storico/2017/12/18/mafanikio_yaliyopatikana_hadi_sasa_chini_ya_rais_john_Dr._Dr._Magufuli/sw-1355394)
52. Rahman, K. (2019). *Transparency International Anti-Corruption Helpdesk Answer Overview of corruption and anti-corruption in Tanzania*.
53. Reuters Staff. (2016, October 29). *Tanzanian president tells security forces to pursue wildlife poachers*. Reuters.  
<https://www.reuters.com/article/uk-tanzania-wildlife-idUKKCN12T0P1>
54. Reuters Staff. (2017, February 2). *Tanzania's President Dr. Dr. Magufuli vows to toughen tax evasion crackdown*. Reuters.



- <https://www.reuters.com/article/tanzania-taxation-idUSLSN1FN7MI>
55. Reuters Staff. (2019, September 5). Tanzania seizes ivory tusks equivalent to 117 elephants killed | Reuters. <https://www.reuters.com/article/us-tanzania-poaching-idUSKCNIVQ13V>
56. Russo, C. (2014, November 10). Q&A: Report Alleges Governments' Complicity in Tanzanian Elephant Poaching. History. <https://www.nationalgeographic.com/history/article/141108-tanzania-ivory-smuggling-china-world-elephants-animals>
57. SAHO. (2019). Tanzania and its Support of Southern African Liberation Movements | South African History Online. <https://www.sahistory.org.za/article/tanzania-and-its-support-southern-african-liberation-movements>
58. Shekighenda, L. (2020, June 24). Dar rises as medical hub. <https://dailynews.co.tz/news/2020-06-235ef242bd8ffc6.aspx>
59. Shiyo, J. (2017, June 26). Tax justice in Tanzania: Dr. Dr. Magufuli investigating contracts with Acacia Mining | Fingo. Fingo.fi. <https://www.fingo.fi/ajankohtaista/artikkelit/tax-justice-tanzania-Dr. Dr. Magufuli-investigating-contracts-acacia-mining>
60. Spears, L. C. (2010). Character and Servant Leadership: Ten Characteristics of Effective, Caring Leaders. 1, 6.
61. Sumra, S. & HakiElimu (Tanzania). (2017). The impact of the implementation of fee-free education policy on basic education in Tanzania: A qualitative study.
62. Tandon, S. (2018). Gandhi's Educational Thoughts | Education | Articles on and by Mahatma Gandhi. <https://www.mkgandhi.org/articles/Gandhis-educational-thoughts.html>
63. TANROADS. (2018). So who's paying for 148 billion/- project to expand Morogoro Road? <https://www.ippmedia.com/en/news/so-who%E2%80%99s-paying148-billion-project-expand-morogoro-road>
64. Tanzania Invest.com. (2021, February 25). Dar es Salaam Inaugurate New Interchange to Ease Traffic Congestion in Ubungo. TanzaniaInvest. <https://www.tanzaniainvest.com/transport/ubungo-interchange-inauguration>
65. Tasamba, J. (2019). Ex-Zambian president receives anti-corruption award. <https://www.aa.com.tr/en/africa/ex-zambian-president-receives-anti-corruption-award/1668870>
66. TBConline. (2019, October 14). Miaka 20 Bila Mwalimu| Maono ya Mwalimu Nyerere katika Ujenzi wa Uchumi wa Kiviwanda. <https://www.youtube.com/watch?v=do9gq6DCiK8>
67. Tshiyoyo, M. M. (2012). Leading through servant-hood in the Democratic Republic of the Congo: The African context. <https://repository.up.ac.za/handle/2263/31729>
68. United Republic of Tanzania. (2016). 1484575453-3 GN 267—The Economic and Organized crime control (the CEC division) ruleS.pdf.
69. URT. (2015). Drug Control and Enforcement Act No.5 of 2015 | Tanzania Legal Information Institute. <https://tanzlii.org/tz/legislation/act/2015/5-0>
70. URT. (2020). GN-NO.937-OF-2020\_The-Mining-Mineral-Rights Amendment-Regulations-2020.pdf.
71. Walt, V. der. (2019). The leadership crisis in Africa—Approaching it from a worldview perspective. *Journal for Christian Scholarship = Tydskrif Vir Christelike Wetenskap*, 55(1–2), 127–148. <https://doi.org/10.10520/EJC-17a10c3d3d>
72. Xinhuanet. (2020, December 3). UN commends Tanzania over control in drug trafficking: Official—Xinhua | English.news.cn. [http://www.xinhuanet.com/english/2020-03/12/c\\_138871252.htm](http://www.xinhuanet.com/english/2020-03/12/c_138871252.htm)
73. Zubairu, U. M. (2019). Servant Leadership in the Last Decade: A Systematic Review. *Journal of Corporate Responsibility and Leadership*, 6(1), 53–76. <https://doi.org/10.12775/JCRL.2019.003>



# THE HISTORICAL ROOTS OF RELIGIOUS TOLERANCE IN UZBEKISTAN

**Tashmatov Ibragimjan**

*Associate professor, department of History, Uzbek State World Languages University, Tashkent, Republic of Uzbekistan*

---

## ABSTRACT

*The article is devoted to the issues of the emergence of religious tolerance, as well as national and cultural characteristics of development in the Republic of Uzbekistan. The thoughts and ideas of Central Asian enlighteners, as well as the historical roots of religious tolerance, are analyzed. The essence of the development of such religions as Buddhism, Christianity and Islam is revealed.*

**KEYWORDS:** *confession, religious tolerance, mutual enrichment and mutual influence of religious cultures, Buddhism, Christianity, Islam.*

---

## DISCUSSION

*Tolerance is the value and social norm of civil society, manifested in the right of all individuals of civil society to be different, to ensure sustainable harmony between different confessions, political, ethnic and other social groups, respect for the diversity of different world cultures, civilizations and peoples, readiness to understand and cooperation with people who differ in appearance, language, beliefs, customs and beliefs.*

Tolerance is an integral part of the life of a modern person. It is especially important today and the processes that are taking place in the context of globalization in the Central Asian region. This is due to the fact that, firstly, today representatives of 16 confessions and more than 130 nationalities live not only on the territory of our Republic of Uzbekistan. Uzbekistan is a multinational and multi-confessional state. Secondly, since ancient times, the Great Silk Road passed on the territory of Uzbekistan, which stimulated the process of mutual communication and mutual influence of various national and religious cultures. Since ancient times, religions such as Buddhism, Islam, Christianity, and Judaism have coexisted on our land. Thirdly, tolerance is one of the basic principles of the ideology of national independence.

As the first President of the Republic of Uzbekistan Islam Karimov emphasized "It is important to always keep in mind that Central Asia is a region in which countries and peoples are represented, which have their own historical, ethnocultural roots, religious and socio-political

characteristics of the way of life, their own mentality. This requires a very careful, respectful approach. " Uzbekistan is one of the most ancient countries where the earliest religious beliefs originated. This is evidenced by the burial in the Teshik-Tash grotto, the bas-reliefs of Fayaz and Kora-Tepa, and, finally, archaeological surveys currently being carried out jointly with scientists from France and Japan.

The ideas of tolerance have had a strong tradition in education. Famous Central Asian educators and Jadids, such as A. Donish, Avaz Utar, Furkat, Mukimi, Hamza, Aini, Behbudi, Fitrat and others, developed the ideas of friendship and cooperation between peoples in their works. Furkat in his works advocated the study of European science and technology, cooperation with the Russian people. Fitrat - the famous Central Asian educator - Jadid wrote: "There is no doubt that although people profess different religions and live in different countries and belong to different tribes and nations, they are all children of the same human race. In other words, they are brothers. And if so, then they should all love and respect each other's dignity and should bring to life an era of universal brotherhood. When they manage to create a universal brotherhood, then an era of happiness in the life of the world, universal happiness will come." The victory of Good over Evil depends on how much a person can accumulate Good in his soul. In the end, the victory of Good becomes a foregone conclusion.

A culture of reason, increased attention to the problem of educating young people and enlightening society, criticism of outdated lifestyles,



religious and national tolerance, historical optimism, an active civic position - all this brought the enlightenment of Central Asia closer to world educational thought. Behbudi wrote that the cultural history of our people presupposes the coexistence of different confessions "under one roof." And they all must live peacefully and amicably. But the state must guarantee freedom of choice, freedom of conscience. But the laws created should protect everyone: "both Jews and Christians and Muslims." It is characteristic that Christian communities consist not only of foreign merchants from other countries and Christians who fled here from the persecutors in Byzantium, but also representatives of some Turkic nomadic tribes, such as the Guzes and Tokuz-Oguzes. It must be said that the Idea of monotheism had an independent basis in pre-Islamic Central Asia. So, during the reign of Istymi-Kagan (552-576) in the Western Turkic Kaganate, the word "Tengri" (ruler of the world) used the axis to denote the supreme deity perceived as a deified sky. This deity appeared to be invisible, but involved in everyday affairs. It is characteristic that exactly the same process took place in Central Asia and the Arabian Peninsula almost simultaneously. According to the Qur'an (Surah az-Zumar, verses 3-6), some of the Arab idolaters recognized the presence of Allah. A curious transformation of the name of God took place in the minds of the Central Asian peoples after the establishment of Islam. Along with the name of Allah, they used the word "Tengri" to designate it and continue to use even today.

In general, over 10 different religions functioned in pre-Islamic Central Asia. Already at that time, local rulers were distinguished by religious tolerance. In any case, the sources do not note a single fact of the outbreak of war on religious grounds. The peoples of Central Asia, which had deep cultural traditions, having joined the spiritual life of the Muslim world, brought their religious and ethical ideas, legal norms, and customs to Islam. This led to the fact that in such a large historical and cultural region as Maverannahr, Islam acquired specific features, confirming the objective fact that, along with the general Islamic principles that unite the entire Muslim world, there are various religious forms of the existence of Islam.

The values associated with the culture of tolerance have deep roots in the spiritual heritage of the Uzbek people. "For millennia, Central Asia has been a center for the meeting and coexistence of various religions, cultures and ways. Ethnic tolerance and openness have become natural norms necessary for survival and development "[5, pp. 135-136]. In the X century on the territory of modern Uzbekistan, the Sunni direction of Islam, in particular, its Hanafi sense, was established. The teaching of Imam Azam is characterized by the granting of freedom to other religions and local customs, the use of "paradise"

(free expression of personal thought) and "qiyas") (analogy) in legal and theological matters.

Despite the fact that in general throughout the Muslim world from the 10th century up to the twentieth century further development of theology, law, morality, social institutions was recognized as impossible, the ulema of Maverannahr continued "ijtihad" (independent judgment on religious and legal issues).

A vivid confirmation of this is Burkhaniddin Marginaniy (died 1197) and his famous work "Khidaya". The Mongol conquest of Central Asia (XIII century) caused a deep cultural crisis in the region. But, as they say, "there is a silver lining." It was in the process of the liberation struggle that a sharp change took place in the religious beliefs of the country's population, as a result of which the Sufi orders were formed: Yassaviya, Ku6raviya and Naqshbandiya. Central Asian Sufism is a new stage or stage in the development of regional Islam. This is an ideological trend that responded to the dictates of the time, which served the goals of achieving the country's independence, calling for active action, that is, in other words, Islam in the face of Sufism at that time played a spiritual and moral integrative role for Central Asia. It is not for nothing that the Sufis took an active part in the Serbadar movement. It was in such a spiritual environment that the great Amir Timur was born, who was distinguished by a tolerant attitude towards all religions. Thus, in relation to Uzbekistan, religious tolerance is not a concept that has appeared recently, but a deep historical tradition. The tradition of religious tolerance inherent in our people has deep historical roots.

The policy of independent Uzbekistan in the field of religion also serves to strengthen these traditions and enrich them meaningfully. Modern Uzbekistan, remaining true to its eastern traditions, is firmly following the path of building a democratic, civilized society. The freedom of religion guaranteed by the current legislation has created all the necessary conditions to satisfy the religious needs of citizens - representatives of different nations and ethnic groups professing various branches of Christianity, as well as Buddhism, Bahaism, Judaism and the teachings of Krishna. Believers of Uzbekistan freely celebrate all religious holidays. So, from year to year and more and more, Eid al-Adha and Ramadan-Khait, Easter and Christmas, Passover, Purim, Hanukkah and other religious holidays are celebrated. By decrees of President I. Karimov, the holidays Kurban-Khait and Ramazan-Khait were declared days off. The Committee on Interethnic Relations and Friendly Relations with Foreign Countries under the Cabinet of Ministers of the Republic of Uzbekistan provides practical and methodological assistance to national cultural centers and thus actively participates in meeting the ethnocultural needs of representatives of





various nations and ethnic groups living in the country.

Summarizing all of the above, it should be noted that the social and political stability achieved in Uzbekistan is the result of a deeply thought-out policy aimed at ensuring interethnic peace and civil harmony in the country.

## REFERENCES

1. Abdunabiev A., Mandralskaya N., Saidova M. *Historical roots of tolerance in Uzbekistan. // Tolerance is the basis of social stability (materials of the scientific-practical conference). Tashkent. 2003.*
2. Alimova D. *Read the Jadids. February 23, 1996*
3. Burkhoniddin Marginoni. *Khidaya: Commentaries of Muslim Law. -T. : "Uzbekistan" 1994.*
4. *Interethnic harmony and religious tolerance - a factor of development. Conference materials. Tashkent, 2003.*
5. Mirzaakhmedova P. Rashidova D. *Jadids: who are they? // Star of the East. 1990. # 9*
6. Adilov Z. Yu. *From the history of religious tolerance in the Republic of Uzbekistan // Young scientist. - 2016. - No. 13. - S. 610-612. - URL <https://moluch.ru/archive/117/32469/> (date of access: 04.12.2019).*
7. Tadjibayeva K. S., Sh E. Y., Akhrolova D. E. *THE GREAT UZBEK WRITER ABDULLA AVLANI'S VIEWPOINTS CONCERNING EDUCATION AND UPBRINGING // Вопросы науки и образования. – 2018. – С. 135.*



# LIFE OF THE RELIGIOUS SERVANT: AS BASIS FOR PERSONALITY DEVELOPMENT OF THE YOUTH

**Orland C. Silvestre**

Laguna State Polytechnic University

---

## ABSTRACT

*The purpose of this study was to know the relationship of Christian life practices of the youth religious servant to their personality development. The research design used in this study was the descriptive method. Random Sampling was used in this research as way of getting the answer from respondent. The statistical treatment of the data was used to compute and analyze the data given by the respondents. This study hypothesized that there is no significant relationship between the Christian life practices and personality development of the youth religious servant was not supported.*

---

## INTRODUCTION

The youth, along with their parents, teachers, church leaders and peers, are searching for their purpose of their life. One essential part of life is faith. This has always presented some difficulty in the process of growing up. Especially now in the contemporary world, there is a great crisis in regard to the Christian faith of the youth. Whether this crisis is really worse today, we think it is highly debatable.

To say that every era of faith has had its problems is not to deny all novelty to our present situation. It is only in the modern era that the question of faith has itself become thematized. The question of faith had previously lain beneath the surface as continuing undercurrent to theological but also to academe discussion. In addition, the Department of Education (DepEd) has defined its one core values being Godly. This is something to deal with the faith of the students, were most of students today are the youth who have the crisis of their Catholic faith. The Christian response to the contemporary crisis of faith is inextricably bound up with the unresolved problems within Catholic faith. The central problem today is that the youth still practicing their catholic faith even though there are many earthly things around them.

To answer that, this research will focus on The Life of the Religious Servant: As basis for Christian Faith of the Youth. Specifically, it sought answers to

the questions: First, what is the level of their Christian Life Practices in terms of: Bible Sharing, Values Formation and Outreach Program? Second: What is the level of their personality development in terms of: Civic Participation; Spiritual Life; and Philosophy in Life? Lastly, Does the Christian Life Practices have significant relationship to the personal development of the religious church servant in Santa Cruz, Laguna?

## MATERIALS AND METHODS

Random sampling was used to this study to select youth respondents selected from the total population.

A lecture or review was sought from Methods of Research professor. All available books, magazines, journals, websites and theses that are related with the study were searched. A self-made questionnaire for the respondents were prepared and these were validated by the selected families of the barangay. After the validation, the researcher asked the permission of the church leader of Sta. Cruz, Laguna about the distribution of the questionnaire to the selected respondents. The distribution of questionnaires is personally administered by the researcher with the help of the people in the different Christian church. After the researcher started to collect, tallied, and computed all the gather information from the questionnaire.



The researcher tool used to find out the about the life of the church servant: as basis for the personality development of the youth that determine the was the researcher-made questionnaire. It consists of questions. Using the four points Likert Scale, the Christian Life Practices and the Personality Development of selected youth religious servant of Sta. Cruz, Laguna.

## RESULTS AND DISCUSSIONS

Level of Youth Religious Servants' Christian Life Practices

The level of Christian life practices was illustrated in terms of bible sharing, values formation, and outreach program.

Table 1 shows the level of Youth Religious Servants' Life Practices in terms of bible sharing.

**Table 1. Level of Youth Religious Servants' Christian Life Practices as to Bible Sharing**

Statements	Mean	S.D.	Verbal Interpretation
1. I read the bible.	2.94	0.722	<i>Practiced</i>
2. I make reflection on the passage I read in bible.	3.16	0.692	<i>Practiced</i>
3. I read bible more than any other book.	2.90	0.798	<i>Practiced</i>
4. I share the things I reflect on the bible.	3.23	0.737	<i>Practiced</i>
5. The bible makes me happy when I read it and share it during the bible sharing.	3.39	0.751	<i>Practiced</i>
<b>Overall Mean</b>	<b>3.12</b>		<b><i>Practiced</i></b>

**Legend:**

- 3.40 – 3.99 *Highly practiced (HP)*
- 2.80 – 3.39 *Practiced (P)*
- 2.20 – 2.79 *Moderately Practiced (MP)*
- 1.60 – 2.19 *Somewhat Practiced (SP)*
- 1.00 – 1.59 *Not Practiced (NP)*

The church servants disclosed that reading the bible makes them happy ( $M=3.73$ ,  $SD=0.510$ ) and that they were able to share their reflections about what they have read ( $M=3.23$ ,  $SD=0.737$ ). The church servants revealed that they make reflections on the passages they have read from the bible ( $M=3.16$ ,  $SD=0.692$ ) and read the bible ( $M=2.94$ ,  $SD=0.722$ ) more often than any other books ( $M=2.90$ ,  $SD=0.798$ ).

The overall mean of 3.12 indicated that the youth religious servants *practiced* bible sharing. They reflected on the passages that they have read from the bible and share them with other people. Based on the gathered data, it shows that even though they are youth they have time to spend on reading the bible and to spread it through their words and action.

The youth religious servants' Christian life practices as to values formation is presented in Table 2.

**Table 2. Level of Youth Religious Servants' Christian Life Practices as to Values Formation**

Statements	Mean	S.D.	Verbal Interpretation
1. I learn about the values formation of the church from the church leader.	3.65	0.539	<i>Highly practiced</i>
2. The values formation teaches me on what is the right thing to do in life.	3.57	0.607	<i>Highly practiced</i>
3. The values formation of the Church gives me comfort when I in trouble.	3.61	0.601	<i>Highly practiced</i>
4. The values formation of the Church brings me closer to God.	3.73	0.510	<i>Highly practiced</i>
5. The values formation of the church influences me to become a good person.	3.71	0.518	<i>Highly practiced</i>
<b>Overall Mean</b>	<b>3.65</b>		<b><i>Highly practiced</i></b>

**Legend:**

- 3.40 – 3.99 *Highly practiced (HP)*  
 2.80 – 3.39 *Practiced (P)*  
 2.20 – 2.79 *Moderately Practiced (MP)*  
 1.60 – 2.19 *Somewhat Practiced (SP)*  
 1.00 – 1.59 *Not Practiced (NP)*

The church servants disclosed that values formation brings them to closer to God ( $M=3.39$ ,  $SD=0.751$ ) and influence them to become a good person ( $M=3.71$ ,  $SD=0.518$ ). The church servants revealed that they learn from the values formation from the church leader ( $M=3.65$ ,  $SD=0.539$ ) and gives them comfort when they are in trouble ( $M=3.61$ ,  $SD=0.601$ ) teaches them on the right thing to do ( $M=3.57$ ,  $SD=0.607$ ).

The overall mean of 3.65 indicated that the youth religious servants highly *practiced* the values formation. The values formation brings them to closer

to God and tell teaches them on the right thing to do. Through the values formation they become good person of the community.

#### Level of Youth Religious Servants' Personality Development

The level of personality development among youth religious servants was indicated by their civic participation, spiritual life, and philosophy in life.

The level of youth religious servants' personality development in terms of civic participation is shown in Table 3.

**Table 3. Level of Youth Religious Servants' Personality Development in terms of Civic Participation**

Statements	Mean	S.D.	Verbal Interpretation
1. I believe my service impact my life and others.	3.69	0.506	<i>Highly developed</i>
2. I help others when I see them facing challenges.	3.65	0.520	<i>Highly developed</i>
3. I reflect good values that are known in my community.	3.58	0.535	<i>Highly developed</i>
4. I promote the sense of Christian values in community.	3.61	0.530	<i>Highly developed</i>
5. I show them on how to deal problem in a Christian way.	3.51	0.628	<i>Highly developed</i>
<b>Overall Mean</b>	<b>3.61</b>		<b><i>Highly Developed</i></b>

**Legend:**

- 3.40 – 3.99 *Highly Developed (HD)*  
 2.80 – 3.39 *Developed (D)*  
 2.20 – 2.79 *Moderately Developed (MD)*  
 1.60 – 2.19 *Somewhat Developed (SD)*  
 1.00 – 1.59 *Not Developed (ND)*

The church servants disclosed that their service impact their life and others ( $M=3.69$ ,  $SD=0.506$ ) and that they help others when they see them facing challenges ( $M=3.23$ ,  $SD=0.737$ ). The church servants revealed that they promote Christian Values ( $M=3.61$ ,  $SD=0.530$ ) and reflect good values that are known in the community ( $M=3.58$ ,  $SD=0.535$ ) show them on how to deal problem in a Christian way ( $M=3.51$ ,  $SD=0.628$ ).

The overall mean of 3.61 indicated that the youth religious servants *highly developed* civic participation. It shows that even though they are serving in church they have the way to participate on the civic affairs of their community.

Based on the gathered data, it can say that the church has a big impact on the civic participation of the youth by being a role model of a good Christian person.





Table 4 presents the level of Youth Religious Servants' Personality Development in terms of Spiritual Life.

**Table 4. Level of Youth Religious Servants' Personality Development in terms of Spiritual Life**

Statements	Mean	S.D.	Verbal Interpretation
1. I always attend the Church Service.	3.70	0.503	<i>Highly developed</i>
2. I focused myself on serving God	3.63	0.544	<i>Highly developed</i>
3. I like to serve in the church.	3.73	0.489	<i>Highly developed</i>
4. I pray the with my co-church worker.	3.68	0.510	<i>Highly developed</i>
5. I attend the formation to become a better servant.	3.65	0.539	<i>Highly developed</i>
<b>Overall Mean</b>	<b>3.68</b>		<b>Highly Developed</b>

**Legend:**

- 3.40 – 3.99 *Highly Developed (HD)*
- 2.80 – 3.39 *Developed (D)*
- 2.20 – 2.79 *Moderately Developed (MD)*
- 1.60 – 2.19 *Somewhat Developed (SD)*
- 1.00 – 1.59 *Not Developed (ND)*

The church servants disclosed that they like to serve in the church ( $M=3.73$ ,  $SD=0.489$ ) and that they always attend Church Service ( $M=3.70$ ,  $SD=0.503$ ). The church servants revealed that they pray with their co-church worker ( $M=3.68$ ,  $SD=0.510$ ) and attend formation to become a better servant ( $M=3.65$ ,  $SD=0.539$ ) focused their selves on serving God. ( $M=3.63$ ,  $SD=0.544$ ).

The overall mean of 3.68 indicated that the youth religious servants *highly developed* spiritual life. It shows they dedicated their selves in serving. Through attending church services with their co-church worker their more involved on developing their personality. Table 5 shows the level of Youth Religious Servants' Personality Development in terms of Philosophy in Life.

**Table 5. Level of Youth Religious Servants' Personality Development in terms of Philosophy in Life**

Statements	Mean	S.D.	Verbal Interpretation
1. My philosophy gives me more understanding of my life.	3.73	0.468	<i>Highly developed</i>
2. My philosophy helps me to become more sensitive person in knowing the condition of other persons.	3.67	0.514	<i>Highly developed</i>
3. My philosophy teaches me to think critically.	3.73	0.489	<i>Highly developed</i>
4. My philosophy helps me to judge objectively.	3.70	0.482	<i>Highly developed</i>
5. My philosophy helps me to face life challenges.	3.71	0.498	<i>Highly developed</i>
<b>Overall Mean</b>	<b>3.71</b>		<b>Highly Developed</b>

**Legend:**

- 3.40 – 3.99 *Highly Developed (HD)*
- 2.80 – 3.39 *Developed (D)*
- 2.20 – 2.79 *Moderately Developed (MD)*
- 1.60 – 2.19 *Somewhat Developed (SD)*
- 1.00 – 1.59 *Not Developed (ND)*

The church servants disclosed that their philosophy in life gives them more understanding ( $M=3.73$ ,  $SD=0.468$ ) and that teaches them to think critically ( $M=3.73$ ,  $SD=0.489$ ). The church servants revealed it help them to face life challenges ( $M=3.71$ ,  $SD=0.498$ ) and judge objectively ( $M=3.70$ ,  $SD=0.482$ )

more sensitive person in knowing the condition of one's person ( $M=3.67$ ,  $SD=0.514$ ).

The overall mean of 3.71 indicated that the youth religious servants *highly developed* philosophy in life. It shows that the church servants were logical and critical thinker. The data gathered revealed that philosophy helps them to know more about the



understanding of life not by their selves but also the people around them.

Relationship between the Youth Religious Servants' Christian Life Practices and their Personality Development

The relationship between the youth religious servants' Christian life practices and their personality development is presented in Table 6.

**Table 6. Relationship between the Youth Religious Servants' Christian Life Practices and their Personality Development**

Variables	Civic Participation			Spiritual Life			Philosophy in Life		
	r-value	p-value	VA	r-value	p-value	VA	r-value	p-value	VA
Bible Sharing	0.634	0.000	S	0.597	0.000	S	0.894	0.000	S
Values Formation	0.617	0.000	S	0.655	0.000	S	0.505	0.000	S
Outreach Program	0.506	0.000	S	0.458	0.000	S	0.448	0.000	S

**Legend:**

- ±0.80 – ±1.00 *Very strong*
- ±0.60 – ±0.79 *Strong*
- ±0.40 – ±0.59 *Moderate*
- ±0.20 – ±0.39 *Weak*
- ±0.00 – ±0.19 *Very weak*

The youth religious servants *highly practiced* values formation and were *highly developed* in terms of civic participation. It was found that there is a *significantly strong* and *positive* correlation between values formation and civic participation ( $r=0.617$ ,  $p=0.000$ ). This means that as the youth religious servants learn from the values formation of the church that brings them closer to God, they were able to become a role model to their fellow youth in the community. Through this values formation they are involved in influencing other youth to also become a good person of the society.

The youth religious servants *highly practiced* outreach program and were *highly developed* in terms of civic participation. It was found that there is a *significantly moderate* and *positive* correlation between bible sharing and civic participation ( $r=0.506$ ,  $p=0.000$ ). This means that as the youth religious servants involved themselves in the outreach program, the more people in needs were given a helping especially during hard times. This indicate that through the initiative of the church the youth were inspired to help other people in the community.

The youth religious servants *practiced* bible sharing and were *highly developed* in terms of spiritual life. It was found that there is a *significantly moderate* and *positive* correlation between bible sharing and spiritual life ( $r=0.597$ ,  $p=0.000$ ). This means that as the youth religious servants read the bible and share their reflections, they were able to have spiritual growth through reading the bible and sharing it to others. It

developed spirituality to become a youth that have a deeper understanding of the word of God that will be a guide to their life.

The youth religious servants *highly practiced* values formation and were *highly developed* in terms of spiritual life. It was found that there is a *significantly moderate* and *positive* correlation between values formation and spiritual life ( $r=0.506$ ,  $p=0.000$ ). This means that as the youth religious servants read the bible and share their reflections, they were able to have learned from the values formation of the church that gives them right values of being a Christian. That it is not only in word but in action.

The youth religious servants *highly practiced* outreach program and were *highly developed* in terms of spiritual life. It was found that there is a *strong* and *positive* correlation between outreach program and spiritual life ( $r=0.458$ ,  $p=0.000$ ). This means that as the youth religious servants gives themselves to help other people through their time and talent that were given by God. It implies that the church servants were not only for the church but also for the people in needs especially in their community.

The youth religious servants *practiced* bible sharing and were *highly developed* in terms of philosophy in life. It was found that there is a *significantly strong* and *positive* correlation between bible sharing and philosophy in life ( $r=0.894$ ,  $p=0.000$ ). This means that as the youth religious servants they read the bible but reflecting it through their action. Because the bible taught them to think morally and



right. So that they can possess what is the true meaning of being a Christian.

The youth religious servants *highly practiced* values formation and were *highly developed* in terms of philosophy in life. It was found that there is a *significantly moderate* and *positive* correlation between values formation and philosophy in life ( $r=0.505$ ,  $p=0.000$ ). This means that as the youth religious servants they learned from the values formation of the church. And this brings them to be more critically and objectively judge what is happening around them. That these experiences were part of their formation.

The youth religious servants *highly practiced* outreach program and were *highly developed* in terms of philosophy in life. It was found that there is a *significantly moderate* and *positive* correlation between outreach program and philosophy in life ( $r=0.448$ ,  $p=0.000$ ). This means that as the youth religious servants through the outreach program it widens the understanding of the essence of helping other people especially those in needs. They can help other people because they understand what they are experiencing.

## CONCLUSIONS

The research reveals that the Christian Life Practices were “Highly Practiced” and their Personality Development were “Highly Developed”

It also confirms that the bible sharing has a “Strong and Positive Monotonic Relationship” to the Civic Participation, Spiritual Life and Philosophy. And the values formation has a “Moderate and Positive Monotonic Relationship”. Similarly, the outreach program has a “Moderate and Positive Monotonic Relationship.”

Therefore, the hypothesis of the study that there is “no significant relationship” between the Christian Life Practices and Personality Development of the Youth Religious Servant of Santa Cruz, Laguna was “not supported” in the study because the results differed significantly.

## ACKNOWLEDGEMENT

The researcher would like to extend his profound and deepest gratitude to the following individuals who have greatly helped his throughout the completion of this research.

Almighty God, for continuous and endless blessings, guidance, strength, wisdom and hope endowed to researcher;

Hon. Mario R. Briones, Ed. D., President of Laguna State Polytechnic University System, for his exemplary, love and untiring service to our university; Dr. Florhaida V. Pamamat, \ Associate Dean of College of Teacher Education, for the time and effort in

correcting and for sharing knowledge in writing research study as well as correction of the write-ups; Dr. Ray Samuel G. Grecalda, thesis adviser and for the time, effort and endless patience in doing this study; Dr. Evelyn E. Balaoro, subject specialist, for the unwavering support in the development of this study; Dr. Harold V. Orignes, statistician, checking this piece of work and for the help extended in treating the gathered data statistically; Dr. Aileen M. Daran, English critic, for correcting the language and content of this work; Mr. Hoseal B. Gayman, university librarian, for providing the needed materials for the completion of this work; Dr. Rose G. Catapang for the care and understanding for the completion of this study; Mrs. Marilou C. Silvestre, his mother for the moral support given to the researcher; Tropang MAX-O, Tropang BNI, Tropang Bingot for encouragement and motivating the researcher to strive hard for this piece of work; Christian Church Leader of Santa Cruz, Laguna, for the approval of the study in his place; And the selected youth religious server, researcher’s respondents, for answering the questionnaire.

## REFERENCES

1. Anderson, Maxwell., *What Is Your Philosophy Of Life? “The fear of death follows from the... | THE WEEKEND READER | Medium*
2. Atkins Robert, Hart Daniel, Markey Patrick, Youniss James, *Youth Bulges in Communities: The Effects of Age Structure on Adolescent Civic Knowledge and Civic Participation - 2004 (sagepub.com)*
3. Chambaere, Kenneth (2014) <https://www.bmcpublichealth-biomedcentral.com/articles/10-1186/1471-2458-13-1055>
4. *Civic participation of high school students: the effect of civic learning in school: Educational Review: Vol 70, No 3 (2014) (tandfonline.com)*
5. *Community Outreach Program: General Activity Guidelines – Center for Community Development (2014) https://www.adnu.edu.ph/ccd/programs-and-projects/community-outreach-program/community-outreach-program-general-activity-guidelines/*
6. Gacos, Seth F. “Values Education: A tool for Close Family ties of selected intermediate students of Silangan Elementary School. Santa Cruz, Laguna. Laguna State Polytechnic University Sta. Cruz, Laguna.
7. Lyubomirsky (2007). *Spirituality Fundamentals of Nursing (8th Ed.)*.
8. Malapaya, Cedric N. (2012). “Anime: Its Effect on the Cultural Behavior of selected BS Broadcasting Students of Laguna State Polytechnic University Sta. Cruz, Campus”. Laguna State Polytechnic University Sta. Cruz, Laguna.



9. *Meaning of Values (2014)* Retrieved from <http://forrester.com>
10. *Motivations for Civic Participation Among Diverse Youth: More Similarities than Differences: Research in Human Development: Vol 12, No 1-2 (2014)* ([tandfonline.com](http://tandfonline.com))
11. *My Personal Philosophy of life. Essays (2014)* ([megaessays.com](http://megaessays.com))
12. *Outreach activities - Youth Off The Streets (2014)* <https://youthoffthestreets.com.au/what-we-do/growth/lifeskills/outreach-activities/>
13. *Pierce C.O. (2004). Emotional and Behavioral Reactions to Social Undermining. Digital Publication.*
14. *Sacro, Mary Grace O. (2013). "Spirituality: Its effect on the Health Status of Patients during Hospitalization". Laguna State Polytechnic University Sta. Cruz, Laguna.*
15. *Spiritual Growth in Christian Life (2015).* Retrieved from <http://www.exploring-spiritual-development.com/FritzOseronReligiousJudgement.html>.
16. *Spiritual Growth Meaning. (2015).* <http://www.allaboutGod.com/spiritual-growth.htm>
17. *The Effect of Television Viewing on Adolescents' Civic Participation: Political Efficacy as a Mediating Mechanism: Journal of Broadcasting & Electronic Media: Vol 53, No (2015).* ([tandfonline.com](http://tandfonline.com))
18. *The Effects of Catholic Schooling on Civic Participation (2015).* SpringerLink
19. *The Importance of Natural Philosophy (2015).* - 1089 Words | Cram
20. *The Uses of Philosophy in Everyday Life (2015).* | Texas Talking Book Program
21. *Walker & Brunner, C. L. (2009). Handbook of the psychology of religion and spirituality. New York: The Guilford Press.*
22. *Why Everybody Needs a Life Philosophy (2015).* ([thriveglobal.com](http://thriveglobal.com)) *Spiritual Growth in Christian Life* Retrieved from <http://www.exploring-spiritual-development.com>





# RELIGIOUS VIEWS AND REPRESENTATIONS IN SAMARKAND ETHNIC CULTURE: A PHILOSOPHICAL PERSPECTIVE

**Bunyod Makhmudovich Yalgashev**

*Basic doctoral, National University of Uzbekistan*

## ABSTRACT

*The article examines the history of the emergence and evolution of religious views and beliefs in the Samarkand oasis. It offers an analysis of the forms of pre-Islamic beliefs among the local population. It also highlights the contemporary occurrences of various syncretic customs and rituals.*

**KEYWORDS:** *totemism, "incense burning", shamanism, fortune-telling, witchcraft, parochialism, Zoroastrianism, Navruz, Christianity, Islam.*

## INTRODUCTION

The spiritual values and cultural heritage of the Uzbek people have for centuries served to increase the cultural value of Eastern civilization. Additionally, the region in which we live is a region where a great variety of religious beliefs and cultures flow in confluence. In short, Uzbekistan is, one of the cradles of not only the East but also the entire human civilization. As the President of the Republic of Uzbekistan Shavkat Mirziyoyev noted on the UN General Assembly, "the invaluable contribution of many brilliant representatives of the Central Asian Renaissance to Islam and world civilization" should be remembered [1].

## THE MAIN RESULTS AND FINDINGS

It is known that in studying the history and culture of each nation, it is necessary to rely primarily on the factor of religion. As the famous English philosopher K. Dawson pointed out, "religion is the key to history, and if we do not understand the religious roots of culture, we cannot understand culture itself." [2] From this point of view, in the study of the ethnic culture of the Samarkand oasis, of course, it is necessary to study the scientific and philosophical aspects of the religious beliefs and views of ethnic groups living in the region.

Historical sources testify that before the introduction of Islam into the life of the peoples of Central Asia, belief in ancestral spirits, magical rituals and cults representing the forces of nature, along with animism, fetishism, shamanism, religions such as Tangism, Zoroastrianism, Buddhism, and Christianity were widespread. [3] In particular, in the

Samarkand oasis, different religions, beliefs and cults were in fact practiced.

Today, a number of ceremonies and rituals are performed by the local population in the Samarkand oasis. Some of these traditions are ancient and are passed down from ancestors to generations in the historical process. In particular, in the pre-Islamic period, the religious thinking of the people of the oasis, like many other nations in the world, was based on primitive-religious views. That is, the religious landscape of the universe had a totemistic, animistic, fetishistic, shamanistic appearance.

Below we will focus on some primitive forms of religion, the elements of which are preserved in the Samarkand oasis to this day.

Fetishism. Fetishism is worshipping in inanimate object that is considered pagan and supernatural - the worship of fetishes played an important role in the lives of ancient peoples.

"Among the objects considered fetish, the most common are human and animal bones and tombstones. Bone remains are believed to protect the fetish owner from natural disasters, diseases, and evil spirits. The tombstones served as an object containing spirits that guarded the peace of the deceased. Worship of the tomb later led to the creation of sacred shrines". [4]

In Uzbekistan, including the Samarkand oasis, the worship of fetishism and adherence to its customs has been preserved for a long time.

With the advent of Islam in Samarkand, the struggle against the remnants of fetishism, such as the belief in the "divine power" of inanimate objects, began. This is because the custom of fetishism in Islam is "shirk." "Shirk is the establishment of the



attributes of Allah to something other than Himself." [5] To be more precise, polytheism is an expectation of a blessing, an event, a request from someone other than Allah, a creature or an object, a hope. However, some complications of fetishism persist even today. According to professor of cultural studies O.Nishonova, "we still have women who believe in the remnants of fetishism. They sanctify inanimate objects and plants, such as eyeglasses, incense, medallions, peppercorns, gooseberries, black pepper, as symbols of protection from harm, protection from eye contact, and good luck". [6] Complications of fetishism persist in the Samarkand oasis to this day. In particular, some residents of the oasis still believe in the supernatural power of incense and red pepper plants. There is no definite information as to when the incense-burning habit arose. However, some believe that when incense is burned or hung on the wall (gate) or cradle of the house, it "touches the eye" and protects people from rocks and disasters. In fact, the incense plant is a medicinal plant, and its body and seeds have been known in medicine since ancient times to relieve a number of diseases when used by boiling it in water or smoking. With the advent of Islam in Uzbekistan, a large part of the local population began to pay more attention to the healing properties of incense, rather than mystical.

Shamanism. Shamanism is a primitive form of religion that embodies the perfect view of the mystical state. Shamanism is derived from the Tungusic word "saman", which means "communicator with spirits", "magician". [7] Shamanistic views have been widespread in Central Asia since ancient times and have played an important role in the history of the Turkic peoples, including the Uzbek people. The term is called "bakhshi", "parikhon", "kushnoch" and "folbin" in the local language.

Bakhshi. Indigenous Uzbek ethnoses viewed people who practiced as bakhshis as "people who heal people with the help of spirits" [8]. Usually, the bakhshis used to heal people who were possessed by evil spirits, such as demons, giants, and *ajina*. Bakhshis perform their duty with strong spiritual excitement and hysteria. Later, the ability of the bakhshis to heal with the help of spirits changed to a state of memorization of various terms, lapars, and epics. As a result, bakhshi plays an important role in the examples of folklore. [9]

Fortune telling. Fortune-telling is also common among the population as a magical form. The Arabic word "Folbin" means "Fol" - destiny, "bin" - seer, that is, the seer of human destiny. [10] If we look at the history of fortune-telling, it is

unknown how long people have been practicing it. But historical sources show that fortune-tellers were very abundant in the ancient Scythian tribes. Some of them tried to practice to see destiny on willow twigs. In this case, the bundles of willows are gathered together, the bundles are untied and the twigs are gathered in a row. Then they look at them and start making predictions. During the recitation, they gather the more twigs one by one and make another nest. This method of divination is inherited from their ancestors. [11]

Fortune-telling is still common among the population of the Samarkand oasis. People who practice fortune-telling are constantly engaged in persuading people, predicting a certain event in their lives, making predictions based on pre-existing symptoms, and determining the cause. Fortune-telling is also forbidden in Islam.

Later, due to socio-economic changes in the way of life of the local population, primitive religious views were transformed into a form of polytheistic belief. In particular, Zoroastrianism is widely developed in Central Asia. Zoroastrianism, which has a long history (II millennium BC – 8-9<sup>th</sup> centuries BC), was the leading religion in Central Asia, especially in Sogdiana (Samarkand). Through the colonial movement of the Sogdians, however, the religion spread throughout the region. Xuan Zian, a Chinese traveler and Buddhist monk who visited Central Asia in the 7<sup>th</sup> century, reported that "the Turks believed in fire, so they did not use a wooden throne". This implies the strong belief of the Turks in Zoroastrianism. [12]

According to Zoroastrian belief, the four elements of nature are recognized as sacred. These are: water, fire, earth and air. From this point of view, human behavior is limited to these elements, sanctifying them. The Zoroastrians, after the death of a person, kept his body away from water, fire, earth and put it on a special hill, and after that they put it in special containers called ostadons. Such ostadons were widely used by the population of Samarkand oasis in 5-6<sup>th</sup> centuries in Payarik, Taylak, Aqdarya, Urgut and Kofirqala regions. In particular, we can mention as examples the "horse-shaped ostadon" found in Payarik district of the 5<sup>th</sup>-6<sup>th</sup> centuries kept in the Museum of Art and Culture of Uzbekistan (Fig. 1), "ostadon lid with a picture of a human head" found in Taylak district (Fig. 3), the "ostadon in the form of a pavilion" found in Mullakurgan village, Akdarya district, the "ostadon decorated in the form of a cross-shaped net" found in the Kafirqala area (Fig. 2), and the "ostadon with the symbol of guards and the sun" found in Urgut district.


**Figure 1.**

**Figure 2.**

**Figure 3.**

The sacred book of Zoroastrianism "Avesto" contains valuable information about the socio-economic and cultural processes of that time, the traditions of the primitive statehood, the role of various social classes in society, family life and related customs and rituals. In particular, the family-marriage relationship, the responsibilities of family members and the head of family are described in detail. Great attention has also been paid to respecting women's rights, ensuring the inviolability and stability of the family, and fulfilling the duties of parents to their children and children to their parents.

In Zoroastrianism, seasonal rituals and family-based rituals have also developed over the centuries. In particular, the celebration of Navruz, ancestral beliefs, lighting a bonfire, wearing a *sidraposh* and wearing a white belt (initiating teenagers into Zoroastrianism) and other ceremonies can be cited.

It is known that fire was considered one of the sacred elements for Zoroastrians. Beruni and several other authors have written that even in the early Middle Ages, when the peoples of Central Asia gathered in groups, common ceremonial meals were cooked, there were special houses for people to gather, and the stoves in these houses were always burning. Uzbeks still light bonfires at weddings and other ceremonies. Zoroastrians believed that fire protects from various calamities and malicious demons, brings happiness and success in life. Fire-related customs are still more common in the Samarkand oasis than in other regions.

Navruz is one of the three most celebrated holidays in Zoroastrianism. Ethnologist D. Dorjjeva, studying the holiday of Navruz among the East Turkestani people, notes that in Abulqasim Firdavsi's famous work "Shokhnoma" Navruz is mentioned as a holiday celebrated in the period when "The Sun enters the Sheep Constellation" (from March 21 to April 20). [13] Navruz is celebrated as the beginning of a new year. This holiday is still celebrated by the people of Samarkand oasis as a national value.

Christianity spread in Central Asia in the 4th and 6th centuries AD. Nestorian temples were built in Samarkand. In the 6th century in Samarkand there was a Christian bishop. In the south of the city lived a Christian community. Doctor of Historical Sciences A. Atakhodjaev described the baptism in the sand found in the pyramid complex in Kushtepa in Urgut district - two men, one sitting and one standing, holding a cross. He also mentions that there are fireplaces belonging to Zoroastrians in this pyramid. This indicates that all religions in Central Asia were in harmony.

In addition, the mausoleum in Samarkand, named after the prophet Daniel, is revered by representatives of Islam, Christianity and Judaism.

It is known that the Uzbeks, who have been under the influence of various religious ideologies for a long historical period, converted to Islam in the early VIII century as a result of the influx of Arabs into Central Asia. The spread of the new religion among the indigenous peoples lasted for centuries. Islam has begun to incorporate ancient religious ideas, customs and rituals, prayers and ideas that are prevalent among the people, taking into account local characteristics. As a result, Islam appears to be somewhat syncretic in Central Asian context. In the beginning, the process of conversion of the local population to Islam was difficult. They did not want to give up their centuries-old beliefs and follow new religious beliefs and customs instead. As a result, the population was forced to pay (increased) life tax and voluntarily converted to Islam.

In its 13th century development, Islam has taken a firm place in the religious beliefs of the people living in the oasis. Today, the daily customs and rituals of the people of the oasis are carried out not only in accordance with the rules of Islamic Sharia, but also in accordance with national historical values. This shows that Islam is perfect in form and content, and that the spirit of tolerance for the



national values and other religious beliefs of any ethnic group is high.

Samarkand has long been an open city for all nations and peoples, where peoples of fire, Buddhism, Christianity, Judaism and Islam have lived in harmony. Tolerance has long been a tradition and value for the people of Samarkand. That is why Samarkand is a unique place of culture of interethnic harmony and interreligious tolerance.

## CONCLUSION

In short, the relations of ethnic groups living in Samarkand region have led not only to the commonality of religious values, but also to the convergence of their daily life, spiritual culture.

## REFERENCES

1. *Speech by the President of Uzbekistan Shavkat Mirziyoyev at the 72<sup>nd</sup> session of the UN General Assembly.* <https://uza.uz/uz/posts/zbekiston-prezidenti-shavkat-mirziyev-bmt-bosh-assambleyasi-20-09-2017>
2. Dawson Ch. *God, History and Historians: anthology of modern Christian views of history.* – New York, 1977. – P. 121. <http://hdl.handle.net/2027/heb.04898.0001.001>
3. А.Аширов. *Ўзбек халқининг қадимий эътиқод ва маросимлари. Монография [Ancient beliefs and ceremonies of the Uzbek people. Monograph]* – Т.: Ўзбекистон Миллий кутубхонаси, 2007. – 5 б.
4. Eliade M. *Shamanism. Archaic Techniques of Ecstasy.* — L.: 1964. P.
5. <https://fayllar.org/z-m-islomov-n-a-muhamedov-f-a-sindarova-dinshunoslik.html?page=2>
6. <https://islom.uz/maqola/166>
7. Нишинова О. *Ўзбек аёллари этномаданияти: генезиси, хусусиятлари, муаммолари (Фалсафий-маданий ёндашув) Фал. фан. ном. дисс. [Ethnoculture of Uzbek women: genesis, features, problems (Philosophical and cultural approach). The dissertation submitted for the degree of Candidate of Philosophical Sciences]* – Тошкент, 2005. -52 б.
8. А.Аширов. *Ўзбек халқининг қадимий эътиқод ва маросимлари. Монография [Ancient beliefs and ceremonies of the Uzbek people. Monograph]* – Т.: Ўзбекистон Миллий кутубхонаси, 2007. – 33 б.
9. *Field records. Payarik district of Samarkand region.* 2020.
10. Сухарева О.А. *Пережитки деменологии и шаманизма у равнинных таджиков // Домусульманские верования и обряды в Средней Азии [Remnants of demenology and shamanism among the lowland Tajiks // Pre-Muslim beliefs and rituals in Central Asia.]* – Москва, Наука. 1975. – 58 с.
11. *Қадимги тарихчилар Ўрта Осиё ҳақида: Терма нарчалар / тузувчи ва таржима Зохир Аълам; Маъсул муҳаррир О.Абдуллаев [Ancient Historians On Central Asia: Compilation / Compiler and Translator Zohir Alam; Editor-in-Chief O.Abdullaev]* –Т.: “YURIST-MEDIA MARKAZI”, 2008. -23 б.
12. *Атаходжаев А.М. Илк ўрта асрлардаги сиёсий, ижтимоий-иқтисодий ва этномаданий жараёнларда турк-сугд муносабатлари. Тарих фанлари доктори илмий даражасини олиши учун тақдим этилган диссертация [Turkish-Sughd relations in the political, socio-economic and ethnocultural processes of the early Middle Ages. The dissertation submitted for the degree of Doctor of Historical Sciences.]* Тошкент, 2011. -136 б.
13. Д.Д.Доржиева. *Новогодняя обрядность уйгуров восточного Туркестана в контексте фольклорно-этнографических данных о Наврузе* // [Электронный ресурс] Вестник Воронежского государственного университета [New Year's rituals of the Uighurs of eastern Turkestan in the context of folklore and ethnographic data about Navruz // [Electronic resource] Bulletin of Voronezh State University.] 2007. №2. – С. 29-36.





# CRITICAL ANALYSES WITH THE HELP OF RECENT LITERATURE TO HIGHLIGHT THE RELATIONSHIP BETWEEN NARCISSISM AND ADDICTION TO SOCIAL MEDIA/NETWORKING

**Huzefa Mandasaurwala**

*Bachelors of Arts (B.A.), Department of Psychology, Jai Hind College, Affiliated to Mumbai University, Mumbai, Maharashtra, India*

---

## ABSTRACT

*Since the first social media sites appeared, the relationship between social media use and narcissism has been a topic of study. According to research, social media use can cause narcissism on the one hand and increase social media use on the other, with a potentially mutual effect between the two. The narcissistic culture is currently being replicated, and narcissism is being encouraged on social media. Social media sites have been found to be an ideal environment for meeting narcissistic needs, and narcissistic behaviours are rewarded. Furthermore, their narcissistic attitudes and behaviours in real life are mirrored in their social media behaviours, and their narcissistic levels rise even further. While numerous meta-analyses have been conducted to synthesise empirical evidence on the relationship between narcissism and typical online behaviours (e.g., uploading photos and usage frequency), evidence on the relationship between narcissism and Problematic Social Media Use (PSMU) has yet to be systematised. The current study is a systematic review on the subject.*

---

## INTRODUCTION

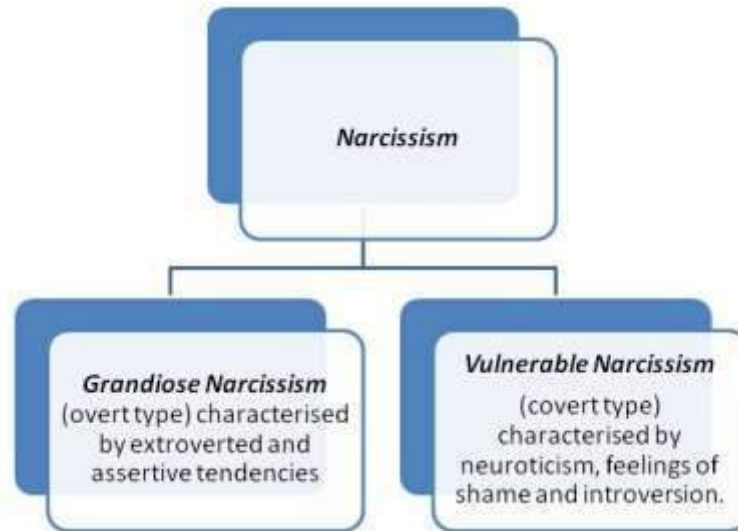
Narcissism is characterised as a tendency to consider oneself better than others, continuously seek respect and validation from others, dwell or be over-considerate of one's appearance and achievements, and engage in self-centred thinking and behaviour.

Like other personality constructs, narcissistic traits among the general population tend to occur along a continuum. The end of that continuum would be Narcissistic Personality Disorder (NPD). However, the report refers to trait narcissism as there is no substantial research done relating social media use with the clinical

population. The report further speculates that the results would be similar. It also includes subclinical narcissism, primarily grandiose narcissism and vulnerable narcissism. Extroverted and assertive tendencies characterise the grandiose 'overt' type of narcissism; this has been linked to a range of social media behaviours, such as time spent, frequency of posts and selfies. On the other hand, the vulnerable 'covert' type is characterised by neuroticism and does not show a stable relationship with social media behaviours.



## NARCISSISM AND ADDICTIVE SOCIAL MEDIA USE



**Fig 1- Sub-types of Narcissism**

Adverse narcissism outcomes include threats to young adults' psychological health, preventing long-term intimate relationships, and aggressive reactions to criticism. However, it has also shown positive outcomes like high self-esteem, openness to experience, extraversion, low anxiety and neuroticism. According to the seven-factor NPI model (Raskin & Terry, 1988), we can distinguish between adaptive and maladaptive narcissism. Adaptive narcissism includes the two factors of authority and self-sufficiency, whereas maladaptive narcissism includes the three factors of entitlement, exploitativeness, and exhibitionism.

### NARCISSISM AND ADDICTIVE SNS USE

While distinguishing between addictive and non-addictive (e.g., excessive, enthusiastic) behaviours, researchers use specific addiction criteria (Griffiths, 2005). Particularly, addictive social media use should be manifested by being preoccupied with social media (salience), using social media so as to cut back negative feelings (mood modification), gradually using social media more so as to induce the same pleasure from it (tolerance/craving), suffering distress if prohibited from using social media (withdrawal), sacrificing different obligations and/ or inflicting harm to other vital areas

of life because of the social media use (conflict/functional impairment), and wanting or making an attempt to regulate the use of social media without success (relapse/loss of control).

Social Networking Sites or SNS are viewed as the perfect tool for narcissists. They allow users to broadcast information about themselves to a considerably extensive network of people. It fulfils the need for praise and attention in a dramatically short period. Moreover, these websites offer complete control over the user's self - presentations, allowing narcissists to create a self-image to their liking. Individuals who value their thoughts, feelings and experiences can publicise them allowing others to validate them using metrics of 'likes', 'shares' and 'followers' 'comments', and several others based on the platform used.

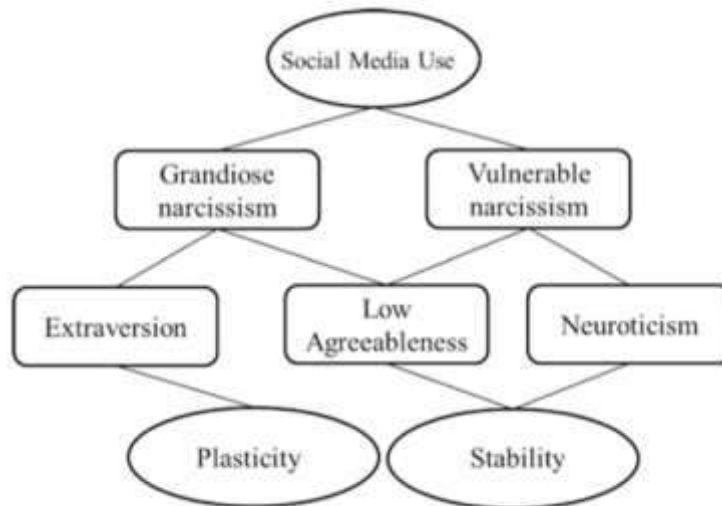
In the research linking addictive SNS use and narcissism, different results emerge when the type and degree of narcissistic traits are factored in. The relationship shared by social media and narcissism has been mainly observed from two standpoints; Social media as a platform for narcissists to receive the attention they desire and social media as a catalyst for increasing narcissism.

Several models can be used to explain narcissism. A prominent model is the Big Five where



narcissism is grounded in low agreeableness, extraversion and neuroticism. A more detailed variant would be the HEXACO model, which includes a factor of humility and honesty. Search for a more detailed tool

would lead us to examine the Big Five at a facet level like the NEO. (6 for each factor; Costa & McCrae, 1992)



**Fig 2- Two- Factor Model of Personality- DeYoung (2015)**

A variation from this approach would be to ground narcissism in a two-factor model meta traits of plasticity (extraversion plus openness) and stability (conscientiousness plus agreeableness minus neuroticism). These are based on a cybernetic trait model (DeYoung, 2014). Majority of the research uses NPI or the Narcissistic Personality Inventory to measure narcissism.

### **CURRENT MODELS OF NARCISSISM AND SOCIAL MEDIA**

Recent research classified SNS usage by narcissists in six theoretical models: the self-enhancement model, fit model, trait model, narcissistic lens model, social network model and cultural model.

Firstly, the self-enhancement model (closely linked to the self-regulation model) states that social media is an excellent medium for self-promotion and enhancement due to its features. In order to fulfil their needs for self-enhancement, narcissists will feel drawn to such a structure. Once they realise that they are receiving reinforcement and validation, social media is viewed as a conducive system, reflecting in their usage patterns (addiction). Narcissists will engage in self-enhancement to an increase in social status. Additionally, also confront those who try to harm their

status. Self-enhancement, primarily seen in grandiose narcissism is done through the self-serving bias, inflating self-beliefs, reporting the better-than-average effect, and over-stating knowledge capability that they could not possibly have. Vulnerable narcissists display self-protection, characterised by avoidance, to protect the narcissist's ego from danger. These distinctions have not been fully agreed upon yet (Wallace, 2011). The challenge with this model is that it has been researched and verified in parts but not whole.

The second model is the fit model. Narcissists have difficulties forming intimate relationships. While social media aims to connect with others, ironically, it is an ideal platform for them. This is because social media is conducive for wide but shallow relationships. This fulfils the need to have an extensive network. Individuals high in grandiose narcissism fit the bill for this type of social interaction. They are attracted to partners who will help them increase their social status and self-esteem and are willing to sacrifice relationships for status.

The third model is called the expanded trait model. In terms of the Big Five personality traits, individuals high in grandiose narcissism have high extraversion and openness and low agreeableness. In light of that, we could view addictive social media use



as an extension of the narcissist's extraversion trait. In contrast, individuals high on vulnerable narcissism show low agreeableness and neuroticism, which suggest anxiety and discomfort with social media use. This suggests that increased social media use is a better fit for individuals high on grandiose narcissism than vulnerable narcissism.

The fourth model is called the narcissistic lens model. This model focus on the traces and marks left behind by a narcissistic in the physical and social world. The metaphor of a lens stemmed from Brunswik's research and is referred to as the Brunswikian lens model. It conceptualises the importance of cues (content on social media) as a mediator in the link between an individual's traits and an observer's perception of them. This does not translate to a conclusion as these cues could also be false. For example, self-promoting photos, flashy clothes and make up would be valid cues; however, the use of "I" in-text would be an invalid cue. One of the early links in this model was found between narcissism and self-enhancing personal email addresses (Marcus, Machilek & Schütz, 2006). The challenge in using this research model is extracting and examining specific cues. These cues can be objective (number of status updates) and less objective (observer's perception). Despite that, the data can be quite valuable (Back, Schmukle, & Egloff, 2010; McCain et al., 2016).

The fifth model is the social network model, which examines narcissism within egocentric (Lamkin, Clifton, Campbell, & Miller, 2014) or socio-centric (Clifton, Turkheimer, & Oltmanns, 2009) networks. Centrality in social networks has two variations: in-degree centrality wherein people report being linked to the target and out-degree wherein the target reports links to lots of people. This link could manifest itself in

several forms - from merely knowing, liking, friendship, or something else. Some studies suggest that grandiose narcissism is linked to out-degree but not in-degree centrality (Clifton et al., 2009; Czarna, Dufner, & Clifton, 2014).

The sixth and the final model is the cultural model that focuses on the interplay of culture and social media. An early approach to this argued that the cultural rise of social media and grandiose narcissism would go hand in hand. Social media provided the opportunity for an enhanced self-presentation and rewards for broad but shallow networks; it created a niche well suited for narcissists. Until the economic collapse (in 2008), this model seemed sufficient; however, since the economic collapse, high unemployment and debt reduced the narcissistic fantasies but did not slow down social media growth. A second model emerged from this called the great fantasy migration hypothesis, which states that the combination of high narcissism and a belief in the collapsing economy would drive people to engage in fantasy to maintain their self-image. Research has shown that both vulnerable and grandiose narcissists engage in geek culture (McCain, Gentile, & Campbell, 2015), an excellent example of the fantasy realm. If the real world has 'failed' the narcissists by not providing enough opportunities, social media can provide a stage for them to fulfil their need for external validation.

Together, these models paint a picture where narcissists engage in self-enhancement to the extent they may sacrifice close relationships. One of the motivations to engage in these behaviours could be engaging in cultural fantasies that may distract them from the disparity of their self-image and their success in real life. Each of these models has implications for the relationship shared by narcissists and social media.

Models	Summary
Self Enhancement Model	Social media is an ideal tool for self-promotion and creating an enhanced image to advertise to the world.
Fit Model	Broad but shallow relationships are preferred by narcissists, and social media is a perfect fit for those.
Expanded Trait Model	Narcissists are high on extroversion, and social media use is an extension of that trait.
Social Network Model	Narcissists engage in varying levels of in-degree and out-degree centrality. This may have implication on their online social media network.
Cultural Model	The belief in the collapsing economy may lead to narcissists migrating to the fantasy of social media, where they can regulate their self-image.

**Fig 3- Research Models on Narcissism and Social Media**





## DIFFERENCES BETWEEN VARIOUS SOCIAL NETWORKING SITES (SUCH AS FACEBOOK & TWITTER)

The growth of individual users, particularly the millennials, has occurred in staggering proportions on the Internet. With addictive usage of Social Networking platforms among the population and such easy accessibility to communication through smartphones, SNS has begun to change the ways people and communities operate considerably. As per 2020 report on the average, Facebook had more than 1.73 billion daily active users (Facebook, 2020); Instagram had more than five hundred million monthly active users and daily shared photos with 4.2 billion daily likes (Instagram, 2020); and Twitter had 330 million monthly active users (Twitter, 2019).

The increasing fan base of such websites has led to the development of numerous Social Networking platforms that cater to specific individuals and particular interests, playing a dominant role in people's social landscapes and platform involvement (Lup, Trub, & Rosenthal, 2015). As Twenge and Campbell (2009) believe, when it comes to addictive SNS use, these online communities promote and nurture a conducive platform for personality traits like narcissism to take place within the form of self-regulation via social connections.

The user metrics show growing popularity for each Twitter and Facebook, with Twitter growing considerably quicker than Facebook (BCS, 2013). Twitter's recent growth highlights its increasing relevance in the discussion of narcissism. Additionally, Twitter has certain innate features that might make it more fertile grounds to narcissistic motives and behaviours than other popular social platforms, such as Facebook.

Facebook is one of the most common and prototypical SNS (e.g., Bergman et al., 2011 and Wilson et al., 2012). Facebook has various features available to users including friend requests, "tagging" others, comments, sharing pictures, and sharing status updates (Tong, Van Der Heide, Langwell, & Walther, 2008) with most of these features promoting interaction between a user and his or her community of friends. Previous research has usually hypothesised and established a positive relationship between numerous peers and narcissism (Bergman et al., 2011, Carpenter, 2012 and Ong et al., 2011), with the rationale that having large numbers of followers would be attractive to narcissists as a measure of importance or popularity. Also, Facebook allows each individual to post their own "status," a personal statement updating their friends on their activities or currently doing.

Recent research has found that people who had high levels of narcissism traits began using Twitter (and other textual-based platforms) more and more over time. However, those who used Facebook addictively (and other visually-based platforms) tended to become more narcissistic over time. This differential association between social media platforms and narcissism is significantly the same as that noted in another piece of research that demonstrated that Facebook and Twitter differed within the aspects of narcissism that drove their usage: those high in "superiority" feelings prefer Twitter, whereas those high in "exhibitionism" prefer Facebook.

## CYBER AGGRESSION, CYBER VICTIMIZATION, AND SEXUALIZED SELFIES

It may even be the case that another side of personality or behaviour links narcissism with addictive social media use. One chance suggested by a recent study, where it had been found that cyber-bullying and cyber-stalking promoted the narcissism-social media relationship. Narcissists have sturdy feelings and need to realise additional power. One way they will try this is to intimidate others, and notably by committing personal cybercrimes. By this, narcissism is connected to social media use, indirectly, through personal cybercrime. The latter social-media action permits the narcissist to dominate and intimidate others on social media. This might be why "grandiose" narcissism, with its more aggressive tendencies, is connected to the addictive use of social media more than the "vulnerable" sorts of narcissism.

A key element in social media that has emerged over the last few years is the advent of selfies. Researchers have linked selfie clicking with the trait levels of narcissism (e.g., Barry et al., 2017; Weiser, 2015). Inherently, sexualised selfies include self-objectification. Since these can be looked as a means to craft a desirable and attractive image online, narcissism is a natural extension. Distinctions in the facets of narcissism are essential here too. The subtype of grandiose narcissism tends to be the most reliable predictor of selfies. However, vulnerable narcissism is also linked to taking selfies that are theme-oriented to physical appearance. (Barry et al, 2017). Overall, grandiose narcissism is more consistently linked to selfies (McCain, Campbell, & Sumerson, 2018).

A study conducted by Stuart et al., 2019 found that taking selfies was strongly associated with frequency of taking self-sexualising selfies and strengthening the purpose of considering the importance of how sub-factors of pathological narcissism are related to selfie behaviours. The current



findings showed that exploitativeness (as part of grandiose narcissism) was related to increased selfie- and sexualised selfie-taking. In contrast, contingent self-esteem (as part of vulnerable narcissism) was associated solely with sexualised selfie-taking. Besides, in line with the hypotheses, selfie behaviour mediates the results of narcissism on cyber behaviours, with both easy and serial mediation effects being evident.

The external validation garnered by the social feedback that comes as a result of this behaviour can, itself, have adverse outcomes for individuals high in narcissism. For example, not receiving likes or a negative comment might threaten the ego, for people with high levels of narcissism, may result in distress and externalising behaviours to heal damaged self-worth (Baumeister et al., 2000). Thus, if the ways of self-promotion fail to evoke the desired response, young women with narcissistic tendencies are also driven to interact aggressively online to diminish others and inflate the self. Alternatively, young women higher in narcissism may click and post increasingly provocative selfies to receive validation and recognition, inadvertently leaving themselves open to victimisation and derogation, a phenomenon dubbed "selfie-shaming" (or victimisations targeted toward one's selfies; Brandes & Levin, 2014).

It was seen that exploitativeness was related to both taking more selfies and taking more self-sexualising selfies. In turn, exploitativeness was also indirectly (via selfies) and directly related to increased negative cyber behaviours. One possible answer for these associations is that people, high in exploitativeness, could manipulate situations to profit. For the young women higher in exploitativeness, taking selfies is also a goal-driven activity used to exploit the digital setting, with gaining attention as their desired outcome. Notably, previous research has suggested that the attention received online does not need to be positive to satisfy its objectives; "if you want to get your peers' attention, the images should be surprising, funny, stunning or provocative" (Willem et al., 2017, p. 88). Therefore, it may be the case that taking selfies. In turn, sexualised selfies, do not seem to be intended by the requirement to be as desirable but could merely imply attention, whether or not positive or negative.

### **ADDICTIVE USE OF SOCIAL MEDIA, DEMOGRAPHICS AND NARCISSISM**

Previous research suggests that younger people were more affected by the addictive use of social media

than older people (Andreassen, 2015). The effect size was between small and medium, so contributes meaningfully to our understanding of addictive social media use. From real world experience as well, this has sensible face validity because the new younger generation (the so-called 'digital natives' and 'screenagers' [Griffiths, 2010]). The research also hypothesised and demonstrated that individuals from the sample who are not in a current relationship would report higher levels of addictive social media use. However, though the findings were statistically significant, the impact of relationships standing on addictive social media use was very small (and unlikely to be purposeful within the current context), and thus without any practical importance.

### **GENDER DIFFERENCES**

Thus, from the previous researches, it can be concluded that entirely different kinds of social media are connected, in several ways, to entirely different aspects of narcissism. This brings to light a different hypothesis during this increasingly complex research: the differences between men and women. Men and women dissent in terms of their propensity to indicate narcissism, a minimum presently in several societies, with greater rates for men (8% of the male population) than women (5% of the female population). Men conjointly score slightly more than women in terms of "exploitative/entitlement" feelings, and "authority/leadership" needs, though there is no distinction in "exhibitionism." However, it seems that this sex difference does not translate into the world of social media in any straightforward manner. Evidence from a range of sources shows that social media has a disproportionately negative impact on women, including on their levels of narcissism and connected behaviour.

A recent study noted that girls reported more addictive social media than boys (43% of girls versus 31% of boys use it for a minimum of an hour daily at age 15). These girls also reported lower levels of happiness and many social and emotional difficulties as they develop. To clarify these findings, girls create comparisons between themselves and others a lot more often than boys. Such social comparison is increased (indeed promoted) on social media, inflicting social media's differentially adverse effects between the sexes.

Research is increasingly showing that such social-comparison for women is an active, and partially aggressive, method that will be deeply related to female



narcissism. In recent laboratory experiments, it was found that women are relatively more likely to use intimidatory self-presentation tactics on social media than men. Echoing the work mentioned earlier, the narcissistic attribute of "exploitativeness" is related to increased selfie taking by women. This will cause increased female aggression, usually inter-female, as well as making alarming problems for the "exploitative" (or, indeed, "vulnerable") narcissist—such as increasingly sexualised portrayals of the self.

This behaviour could get reinforced by the user receiving "likes," which are particularly important for the "vulnerable" narcissist. This reinforcement drives a lot of this utterly inappropriate and self-harming behaviour. However, not receiving "likes" will be even as dangerous for this cluster and their behaviour will lead to a temporary increased level of activity and aggression—a widespread phenomenon of non-reward in the animal laboratory—and several negative impacts on physiology and immunity, through the action of stress hormones—a known result of internet addiction.

## NARCISSISM AND GENETICS

Grandiose or agentic narcissism as measured by the narcissistic personality Inventory (NPI; Raskin & Terry, 1988) is widely researched. 2 studies have examined its etiology. One study investigated 139 pairs of twins (75 MonoZygotic pairs, 64 DiZygotic pairs) in from the USA and North American nation and found that variations in narcissism were chiefly explained by genetic factors (59%) and non-shared environmental factors (41%) (Vernon, Villani, Vickers & Harris, 2008). They examined 304 pairs of twins (152 MZ, 152 DZ) in China's completely different culture. It was found that genes (47%) and non-shared environments (53%) chiefly influenced narcissism (Luo, Cai, Sedikides, & Song, 2014). These findings suggest that about half of grandiose narcissism's variation is attributed to genetic influence, with the remaining half attributed to non-shared environmental influences, a pattern that holds across cultures.

Based on the same twin sample, they surveyed adaptive and maladaptive narcissism in a second study. Adaptive and maladaptive narcissism are shaped on the idea of the seven-factor model of NPI (Raskin & Terry, 1988). Adaptive narcissism includes the two factors of authority and self-sufficiency, whereas maladaptive narcissism includes the three factors of entitlement, exploitativeness, and exhibitionism (superiority and vanity factors were not used). Past research showed

that these two styles of narcissism have distinct personality foundations and adaptive functions. The twin study found that each of the adaptive and maladaptive narcissism was heritable (37% and 44%, respectively), with the individual variations, for the most part, explained by non-shared environments (63% and 56%, respectively) (Cai, Shi, Fang, & Luo, 2015). Moreover, 54% of the genetic effects and 85% of the non-shared environmental effects on adaptive and maladaptive narcissism varied. These findings indicate that although adaptive and maladaptive narcissism share some genetic (46%) and environmental (15%) evidence, the bulk of their variations are determined by different genes and environments, providing evidence for the distinctiveness of adaptive and maladaptive narcissism.

To summarise, narcissism is heritable despite its manifestations. The environment is the non-shared environment (e.g., specific life events) instead of the shared environment (e.g., shared physical family) exerts substantial influence on narcissism. These findings are in line with a large body of twin studies on personality (Bouchard, 2004). Firstly, genetic and environmental influences on narcissism vary with its manifestations, with larger genetic influence on overall narcissism (e.g., agentic narcissism and communal narcissism) than its components (e.g., adaptive narcissism and maladaptive narcissism). Second, all contrastive manifestations of narcissism are considerably (although, not entirely) dissimilar in their genetic and environmental foundations.

## METHODS

Electronic literature databases were searched to identify studies that examined the relationship between narcissism and PSMU. This systematic literature review is guided by the Cochrane method, and the search method and findings are presented in accordance with the relevant sections of the Preferred Reporting Items for Systematic Reviews and Meta-Analyses (PRISMA) guidelines (Higgins and Green, 2011, Moher et al., 2009). Studies were included in the systematic literature review based on the following inclusion criteria: they must (a) quantitatively examine and report the relationship between grandiose narcissism, vulnerable narcissism or both, on the one hand, and problematic use of social media or specific social media platforms (i.e., Facebook, Instagram, Twitter), on the other hand; (b) use a multidimensional conceptualization of PSMU; (c) be published in an



academic journal not before 2016; and (d) be available in English.

This systematic literature review has a focus on narcissism and Social Media Usage at the subclinical level rather than at the clinical level in order to increase the generalizability of the findings, as understanding personality and behaviors as traits allows for greater flexibility and a deeper understanding. Moreover, the vast majority of the studies in the social media field have been conducted with non-clinical populations.

## CONCLUSION

In the current day and age, using excessive social media is considered normal behaviour. The structure of social media platforms is meant to have a direct relationship between time spent and rewards acquired. These rewards are in the form of likes, shares, upvotes, retweets, going viral, just to name a few. The subtle psychological rewards can come in the form of external validation, acceptance, increase in connections, a platform to display new talents or promote new ventures. Well established are the compromises that come with these benefits - social comparisons, setting unhealthy standards for yourself, losing touch with reality, addiction and creation of unfulfilling relationships. Not only has narcissism become a controversial trait with many now advertising its relationship with success, it has become increasingly complex to measure. The essay has attempted to understand the various lenses through which we can view the relationship between SNS usage and narcissism.

While years of research are still required for scholars to settle on a theory which they can validate, it is indisputable that the relationship exists. The limitations of the research are immense with most relying on self-reports and lack of platform specific tools. With increasing advancement in technology, it may be possible for researchers to understand social media usage without these limitations with artificial intelligence. A future where the study of narcissism could lead to identification of people at risk through analytics of social media usage may not be far. It may be worthwhile to note that with the studies done in learning - the reinforcement model along with the rewards of social media may be nurturing a generation where narcissism may be a necessary evil.

## LIMITATION

This area of research, is almost a decade old, is now seeing some replicable studies and relationships with grandiose narcissism. In the direction researchers are heading in, there may even be a need to re-evaluate what they consider to be normal so they can avoid labelling the next generation as dysfunctional under their current definitions. It is an area of research which is going to be extremely exciting to watch out for.

## REFERENCES

1. Andreassen, C. S., Pallesen, S., & Griffiths, M. D. (2017). *The relationship between addictive use of social media, narcissism, and self-esteem: Findings from a large national survey*. *Addictive behaviours*, 64, 287-293.
2. Barry, C. T., & McDougall, K. H. (2018). *Social Media: Platform or Catalyst for Narcissism?*. In *Handbook of trait narcissism* (pp. 435-441). Springer, Cham.
3. Barry, C. T., Doucette, H., Loflin, D. C., Rivera-Hudson, N., & Herrington, L. L. (2017). "Let me take a selfie": Associations between self-photography, narcissism, and self-esteem. *Psychology of popular media culture*, 6(1), 48.
4. Campbell, W. K., & McCain, J. (2018). *Theoretical perspectives on narcissism and social media: The big (and beautiful) picture*. In *Handbook of Trait Narcissism* (pp. 443-453). Springer, Cham.
5. Davenport, S. W., Bergman, S. M., Bergman, J. Z., & Ferrington, M. E. (2014). *Twitter versus Facebook: Exploring the role of narcissism in the motives and usage of different social media platforms*. *Computers in Human Behavior*, 32, 212-220.
6. Luo, Y. L., & Cai, H. (2018). *The etiology of narcissism: A review of behavioral genetic studies*. In *Handbook of Trait Narcissism* (pp. 149-156). Springer, Cham.
7. McCain, J. L., & Campbell, W. K. (2018). *Narcissism and social media use: A meta-analytic review*. *Psychology of Popular Media Culture*, 7(3), 308.
8. Panek, E. T., Nardis, Y., & Konrath, S. (2013). *Mirror or Megaphone?: How relationships between narcissism and social networking site use differ on Facebook and Twitter*. *Computers in Human Behavior*, 29(5), 2004-2012.
9. Singh, S., Farley, S. D., & Donahue, J. J. (2018). *grandiosity on display: Social media behaviours and dimensions of narcissism*. *Personality and Individual Differences*, 134, 308-313.





10. *Stuart, J., & Kurek, A. (2019). Looking hot in selfies: Narcissistic beginnings, aggressive outcomes?. International Journal of Behavioral Development, 43(6), 500-506.*
11. *Wickel, T. M. (2015). Narcissism and social networking sites: the act of taking selfies. Elon journal of undergraduate research in communications, 6(1).*



# THE SEMANTICAL STRUCTURE OF LANGUAGE UNITS EXPRESSING THE LEVEL OF A SYMBOL

**Nilufarkhon Ravshanovna Makhmudova**

*Teacher of Andizhan State University, Andizhan region, Republic of Uzbekistan*

Article DOI: <https://doi.org/10.36713/epra1683>

DOI No: 10.36713/epra1683

---

## ABSTRACT

*In the article, the semantic structure of language units representing the hierarchy of a character is analyzed in detail using data from the scientific literature. Besides, this work clarifies the issue of the structure of the meanings of lexical-semantic means (lexical-semantic indicators of graduality) representing gradation as well.*

**KEY WORDS:** *lexical layer, character, hierarchy, language units, semantic structure.*

---

## INTRODUCTION

The lexical layer is the main layer that represents the gradual category. In this regard, it is necessary to clarify the issue of the structure of the meanings of lexical-semantic means (lexical-semantic indicators of graduality) representing gradation. Because the structure of this indicator determines its function in language and speech, its pragmatic nature, that is, its possibility of application in one or another type of discourse.

## METHODS

This analysis is based on the theory of multicomponent structure of lexical meaning [1, p.19]: denotative-signifiable (D-S), connotative (K), grammatical (G), sociolinguistic (S-L) [1, p.20] macrocomponents were isolated. Each of the listed macro components consists of a set of semaphores that provide the appropriate type of information.

## RESULTS AND DISCUSSIONS

Lexical-semantic indicators of graduality are represented by LB, which fixes the gradation of the character in the text. In their semantic structure, as in the semantic structure of all words, the aforementioned macrocomponents are identified. According to the study, content macrocomponents have different ratios in different lexical-semantic indicators. One of the macrocomponents specific to the meanings of gradation indicators may be

amplified and have the status of a key component, which affects its function in speech and determines its applicability in appropriate discourses.

Lexical-semantic indicators of graduality in terms of the ratio of denotative-signifiable and connotative macrocomponents are divided into two main groups: nominative indicators and connotative indicators.

The first group consists of lexical-semantic indicators, in which the denotative-signifiable macrocomponent is the main, and the connotative meaning is weakened. The meanings of these types of indicators perform a nominative function, in this respect the indicators are called nominative: *very surprised, special attention, extreme poverty, much more enjoyable, a few seconds, a little excited: but because you have often heard me say so—was then a much larger and better place, and a much more valuable property than it is now.* (Charles Dickens, *The Barnaby rudge*); *“you are a little ruffled and out of humor. I’ll wait till you’re quite yourself again. I am in no hurry.”* (Charles Dickens, *The Barnaby rudge*)

In the group of nominative lexical-semantic indicators by function can be distinguished the following types:

- Indicators whose main task is to determine the degree (intensity, size, degree, etc.). The denotative-signifiable macrocomponent in the content of indicators is manifested only in gradual semaphores: completely different - completely



different meaning, such serious contacts - such serious relationships. Indicators that do not have the main function of determining gradality. The denotative-signifiable macrocomponent has gradual semaphores, but they are not unique and primary. For example, the main function of grief LB is to determine the emotional state, but in the denotative-signifiable macro component of the content are also identified gradual semaphores that provide information about the greater degree of manifestation of the sign: grief = "pain, deep grief, mourning." Among the nominative lexical-semantic indicators of graduality, there are indicators in which both denotative-signifiable and connotative macrocomponents are expressed in meaning, with evaluative and gradual semaphores appearing as nuclear semaphores. The meanings of these indicators perform a nominative-evaluative function, in this regard we call them nominative-evaluative indicators of graduality: *highly appreciated, fundamental difference, qualitatively new level and etc.*

Connotative lexical-semantic indicators of graduality include LB, which has both a denotative-signifiable and a connotative macro component, but the connotative macro component is the main one. The meanings of these indicators perform a connotative-descriptive function: scaryscandal - a terrible quarrel, astronomicalsum - a price in heaven, inhumanvanity - inhuman anger, rage.

Like nominative indicators, connotative indicators are divided into two groups according to their function:

1) Indicators whose main function is to determine graduality: terrible long break, monstrouspower - terrible power, cruelpunishment - cruel punishment, scarynoise - horrible (ear-piercing) noise, sharplook - sharp gaze, colossalbuilding - huge building; aterriblylongpause, anunimaginablecrush.

2) Indicators that do not have a primary function of determining graduality: amazement, anger, love, noise, serenity, despair. For example, the main function of the word amazement is to define an emotional effect, although in the context of this word gradual semantics are also presented: to be surprised, = "to make a great impression".

According to the derivational type of lexical meaning, both nominative and connotative lexical-semantic indicators of graduality can be divided into primitive and artificial types. The presence of gradual semaphores in the content of root-specific indicators cannot be explained at this stage of language development, as the internal form of these LBs is lost: quite stunned, very noticeable, completely different meaning, meticulous, frustrated, distracted (nominative indicators); rude people, overjoyed, great fight, open-mouthed, stunned, stubborn, stubborn, overly respectful, esteemed, victorious (connotative indicators). The existence of gradual semantics in the meanings of nominative-

constructive and connotative-constructive indicators can be determined by the meanings they represent (semantic and word-forming). For example, gradual semaphores (destructive precipitation mixed with wind, rain, and snow) defined in the semantics of a storm horse, the word flood in semantic derivation includes the main nuclear semaphores in the sense of "something strong manifestation": the storm of perceptions.

The horror generated by word-formation from the horse is used to describe the "very strong" gradual semaphore. intensity semaphores become active, intensify, and take on the status of chief nuclear semaphores: terribly hot, terribly beautiful, terribly hungry. In speech, cases are identified in which gradual indicators reinforce occasional meanings. Gradual semaphores appear as peripheral semaphores in the sense that they form these indicators. In speech, they become more active and stronger, as a result of which the word acquires an occasional content, which is activated only in a certain speech situation: the teeth fall out and become "bald", and so on.

In the sense of connotative lexical-semantic indicators the following can be strengthened:

- Emotional semaphores: angry gestures, hopeless courage, earnest desire, insane speed, cruel laughter, brainwashing, staring, stunned, chubby child, dreaming, screaming, shivering with fear dr. ;

- emotional-evaluative semantics: a) positive: mature professionals, brilliant success, blessed, beautiful place, extremely beautiful lines, luxurious place, great gift, excellent stage work, great organization; b) Negative: opponent, unpleasant, sad situation, fatal shooting, fatal outcome. In the nuclear part of the meanings, both denotative-signifiable and connotative semantics appeared (the semantics of "rational evaluation", "character level" are denotative, emotional evaluation and emotional semantics are connotative). The meanings of indicators perform a connotative-evaluative function, in this respect we call them connotative-evaluative;

-imaginary semaphores: industrial giants, a storm of negative emotions: In our country, there are successful manufacturing enterprises established in cooperation with the famous German industrial giants - MAN, Claas, Knauf and others. Bilateral cooperation in the automotive industry is developing rapidly. (<http://nv.chamber.uz/uz/news/3997>); We continue to watch and listen while the giants of the industry are continuously rewarded by their minions ingovernment [2].

The meanings of connotative lexical-semantic indicators can be enhanced by the combination of different types of semantics:

-rational-evaluative and emotionally-evaluating semaphores: masculine power (positive rational-evaluative sema and positive emotional-evaluative sema); victory (positive rational-



evaluative and emotional-evaluative semantics): *Philip gave him back the letter. He felt a thrill of pride in his triumph. He had got his own way, and he was satisfied. His will had gained a victory over the wills of others.* (W.Somerset Maugham, *Of Human Bondage*);

-emotive and rational-evaluative semaphores: being lazy from the heat (emotion semen "suffering", negative rational-evaluative sema); burning with joy (emotion of "satisfaction", positive-evaluative sema); suffering (emotion of "suffering", negative rational-evaluative sema);

-emotional, rational-evaluative and emotional-evaluative semaphores: rude candidates (emotive seismic "anger", negative rational-evaluative and emotional-evaluative semaphores); cruel hatred (emotional semaphore of "enmity", negative rational-evaluative and emotional-evaluative sema);

- figurative, rational-evaluative and emotional-evaluative semantics: magnificent hundred years (figurative semantics, positive-rational-evaluative and emotional-evaluative semantics); fairy-tale life (figurative semantics, positive rational-evaluative and emotional-evaluative semantics);

- figurative, emotional, emotional-evaluative and rational-evaluative semantics: exile (in the sense of "very difficult, painful situation, life" - figurative semantics, emotional semantics of "suffering", negative rational-evaluative and emotional-evaluative semantics); inhuman laws (figurative, emotional cruelty, negative emotional-evaluative and rational-evaluative semantics); venomous gaze (figurative semantics, "hostile" emotional semantics, negative emotional-evaluative and rational-evaluative semantics).

The considered connotative lexical-semantic indicators of graduality can be called expressive. Given the fact that the concept of expressiveness is interpreted differently by scientists [3], it should be noted that in this work expressiveness is understood as the compatibility of one of the connotative semaphores with the semaphore of "large degree of character gradation." Expressive semaphores can consist of emotive semaphores, emotionally evaluative, figurative semaphores, if they are presented with gradual semaphores (especially intensity semaphores). It should be noted that the degree of expressiveness may vary. The more types of connotative semaphores are amplified in harmony with the intensity semaphore in the connotative macrocomponent, the higher the level of expressiveness of the meaning of the lexical-semantic index. Lexical-semantic indicators of graduality are characterized by a minimal level of expressiveness, and their connotative macrocomponent is enhanced by the combination of intensity semaphores with a kind of semaphore: with unmotivated figurative semaphore the absence forms a peculiar non-

ambiguity of the content, and this enhances expressiveness; with emotive sema (toddler - small chubby child, baby) and others. The average level of expressiveness is characteristic of lexical-semantic indicators, whose connotative macrocomponent consists of two types of intensity semaphores: emotional and emotional-evaluative sema (rude candidates), figurative and emotional-evaluative semaphores (magnificent century). It has lexico-semantic indicators for maximum level of expressiveness, the connotative macrocomponent of which is enhanced by the combination of intensity semaphores with three types of semaphores: figurative, emotional and emotional evaluative semaphores (inhuman laws).

When we consider the specifics of the macrocomponent of meanings specific to the lexical-semantic indicators of graduality, it is possible to distinguish indicators with grammatical indicators. These include the LB, which represents the grammatical category of the level of comparison: the more serious the situation, the most beneficial, the most successful, the most important day, the lowest result.

In the macro component of lexical-semantic indicators of graduality can be presented semantics that provide information about the style, the possibility of using the word in certain discourses. In this regard, we highlight the stylistically defined indicators. These types of indicators may have the following characteristics:

- Literary style: so much, so much, really. In this group, lofty words are singled out: to dream, to honor (carry in the head), to grieve hard: Salim ota Bianada, who once dreamed of the loss of oppressive rulers by a people who lived by honest labor, was uplifted by this dream. (Pirimqul Kadyrov, Humoyun and Akbar). These types of indicators are used in mass communication discourses;

-Speech style: among the indicators that are distinguished by an exaggerated, insidious, throwing style of speech, there are words that are typical of ordinary vernacular: - Lord, these words are a slander against a strong figure like you! (Pirimqul Kadyrov, Humoyun and Akbar); as far as power is concerned, at least, sal-pal, this type of very verbal indicator is used in informal communication discourses that do not obey the boundaries of etiquette. Anwar tried his best not to give away the secret, even though he was filled with this poisonous word like a snake. (Abdullah Qadiri, Scorpion from the Altar); Put it down! I'm totally back from you. I washed my hands and hit my armpits! Holmurod waved. Then he looked at Hakimov with hope and continued in a sad tone. Let me look at someone's husband in the eyes of this man, let me be a liar ... (Said Ahmad, The Sun).





## CONCLUSION

Thus, in the meanings of lexical semantic indicators are denotative-signifiable, connotative, grammatical and sociolinguistic macrocomponents. Nominative and connotative lexical-semantic indicators of graduality are distinguished according to the ratio of denotative-signifiable and connotative macro-components of meaning. According to their function, nominative and connotative indicators are divided into two groups: 1) indicators whose main function is to determine graduality, and 2) indicators whose main function is not to determine graduality. According to the derivational type of content, nominative and connotative indicators are divided into artificial and non-artificial indicators. Connotative indicators are characterized by minimum, medium, and maximum levels of expressiveness depending on the type of connotative semantics, which are presented in conjunction with graduality (intensity) semantics in the sense of indicators. Lexical-semantic indicators of grammatically and stylistically marked graduality are also distinguished by the specificity of the function.

## REFERENCES

1. Pelepeichenko L.N. *Transitional types of meanings of words (based on the material of the Russian language)*. - Kharkiv: KhGPU, 1994. - P.19-20
2. [https://www.huffpost.com/entry/how-our-leadership-canso\\_b\\_825168](https://www.huffpost.com/entry/how-our-leadership-canso_b_825168)
3. Pelepeichenko L.N. *Transitional types of meanings of words (based on the material of the Russian language)*. - Kharkiv: KhGPU, 1994. - P.138.



# THE CONTENT OF YOUTH EDUCATION IN KARAKALPAK FAMILIES BASED ON FOLKLORE

**Amangul Doskhodjaeva**

*Senior teacher of the department of "General pedagogy and psychology"*

*Nukus state pedagogical institute named after Ajiniyaz*

Article DOI: <https://doi.org/10.36713/epra7273>

DOI No: 10.36713/epra7273

## ABSTRACT

*Like all peoples of the world, the Karakalpak people have always paid great attention to the upbringing of children in the family. The upbringing of a child in the family, is considered to be an integral part of life. Good results can be achieved if this process is carried out using the oral traditions of the people. Art of folklore traditions tested in the life of the people have been a spiritual food for thousands of years and serve as a tool of folk pedagogy and education. It is analyzed that folklore is the rich educational tool which used by the Karakalpak people in the upbringing of children.*

**KEY WORDS:** *Karakalpak people, family, upbringing, oral folklore, children's songs, national traditions, spirituality*

## INTRODUCTION

Like all peoples of the world, the Karakalpaks pay great attention to upbringing children in a family. People of Karakalpakstan widely used oral folklore samples for the effective implementation of upbringing children in the family. The question of upbringing a child in a family began at birth. The process of the primary upbringing of a child, purposefully expected in the family, was carried out through maternal love.

## METHODS

Lullaby is a genre of oral folk literature. Lullabies are the basis for upbringing a child, which are closely related to the spiritual development of a deeply meaningful human life. The reason - love, hope, confidence in a child, lullabies arising from maternal love, which has reached every maternal happiness, or a new family member, a lullaby, emanating from the love of each family member for the expected child, affects the accumulation of spiritual substances, like happiness. The spirituality of a child is divided into emotions, deep feelings, and also love and good qualities are manifested in him. Nothing can replace this education, which began in the family. There are several units in lullabies that are

concentrated in a very strong, pleasant voice that also attracts adults.

## RESULTS AND DISCUSSIONS

The first is the love of a mother and a relative, the second is a pleasant voice that is necessary for the child's body, the third is the attitude towards the baby, upbringing, the trust given to him as a continuer of human life, the load is not only a simple song, but also a teaching tool.

Aynalayin appaġim,  
Qozi júnli qalpaġim,  
Qozim meniń gúl bolġay  
Jiynaġanim toy bolġay  
Toyim-toyġa ulasqay  
Da'wlet kelip ornasqay [1; p. 7].

In our example, the lullaby is one of the lullabies that have been active since ancient times. The dreams of a mother rocking the cradle make the baby look like a delicate beautiful flower, like a beloved lamb. These comparisons are an explanatory artistic tool recognized by pastoralists. There are also words for a mother to caress her baby. In lullabies with good intentions, she represents the future of her child, she wants to see his good days and arrange weddings.



The task and intention that parents put in the family are very high, and the child begins to grow from the cradle. The upbringing that begins with the diaper gradually develops. A newborn baby does not understand the content of lullabies, only hears music with a pleasant voice. A pleasant sound affecting the child, soothes him and puts him in a sweet sleep. Through the lullaby, the child receives spiritual nourishment. Lullabies, which are closely related to human life, are accompanied by music that reveals the secrets of the mother. An example of lullabies that appeared in past centuries:

Meniñ balam baldaydı  
Beline sadaq baylaydı  
El shetine jaw kelse  
Dürkiretip aydaydı [4, p. 257]

The mother loves her sweet child. When he grows up, he will be a brave young man who will protect his people from enemies by repeating these duties while the child is in the cradle. Foundations of education, born in the cradle, seek solutions to the problems of their time. We can also see these traditional ways in modern examples of lullabies.

Hayda, hayda haydasın -ay  
Aralım meniñ jaralı-ay  
Qayta tolip Aralım-ay  
Molaysın balam shadlı toy-ay  
A'miwimmen aqqan suwlar  
Ilaylansın jan balam-ay  
Eli-xalqimniñ nesibesi  
Moldan bolğan jan balam-ay [2, p.95].

This is what is recognized in our time by the fate of the Aral Sea, which suffered from an ecological disaster. A mother's dream of replenishing the sea, for her future child, in addition to a lullaby, is looking for a solution to the problems of that time. Or in the lullabies of some mothers who could not get along with their loved ones:

Qizim meniñ quralay-ay  
Qulağıñda júp sirğa-ay  
Suwgeni bolğay bir mirza-ay  
Men bolayın bir ırza-ay  
Haya-haya, haydası-ay [4, p.59]

So she wishes happy to her daughter.

Every day a growing child tries to walk. Parents look at these things with great attention, caution, and carry out a traditional ritual in the family "Tusaw kesiw" (Pruning of fetters). This is the cutting of the fetters on the legs, symbolizing the beginning of a new stage in the child's life - the ability to walk, to learn about the world.

In the song «Tusaw kesiw» among the child's relatives, a rich, energetic man cuts the child's restraint on the legs.:

Ğaz-ğaz balam, ғаз balam  
Qurısқан boydı jaz balam,  
Gürmewiñdi shesheyik,  
Tusawıñdi keseyik,

Qutlı bolsın qádemñ  
Kóz timesın tükireyik  
Ómirge ayaq basa ber  
Asıwlardan asa ber  
Xalıqshıl bol erinbe  
Ilgeri bas sheginbe [4, p.25]

There is great concern and purpose in this rite for the child. This is how folk pedagogy lives in folklore, which is aimed at making a child a correct, educated and big person.

In the family, the child gradually begins to understand the functions, the meanings of words. His dedication to life prompts him to begin studying the alphabet of the philosophy of life. People who deeply understand such needs of a child in the family gradually brought him to the structural stages of life, creating children's songs, poems, fairy tales, riddles, legends, proverbs dedicated to children in folklore.

In Karakalpak folklore, there are several songs dedicated to children, for example, "Há túlkishek, túlkishek", "Há tųyeler, tųyeler", "Áwelemen-dųyelemen", "Ertek", "O'tirik ólen", "Shaq shağala", "Hákke qayda". Many of these songs are performed with games in the form of dialogue. The culture of language development, speaking on the basis of these songs, which are sung in a fun, humorous and light form dedicated to children, love for the Motherland, learning to work, virtue, the fight against arrogance and cruelty.

For example, in the song "Há túlkishek, túlkishek":

- Há túlkishek, túlkishek  
Túnde qayda barasañ?  
- Mamamniñ úyine baraman.  
- Mamañ sağan ne berer?  
- Eshkı sawıp sút berer?  
Eshkısınıñ súti joq,  
Ilağıniñ putı joq.  
Taram-taram et berer.  
- Onı qayda qoyasañ?  
- Tal túbine qoyaman.  
- Iyt alıp ketse ne qılasañ?  
- Iyt awzınan alaman,  
Batıy xanğa baraman.  
- Batıy xanniñ nesı bar?  
Ushar-ushar qası bar.  
Ushıp ketti hawağa  
Qayıp tústi dariyağa  
Dariya suwın qurıttı  
Aq shabağın shırıttı  
Bir baydıñ jurtında  
Eki tishqan urıstı  
Sağal murtın julıstı [1, p.11].

In a series of songs dedicated to children in folklore, such songs in the form of questions and answers about the character of the child develop the child's ability to remember. They are taught to understand the content of the question and answer it clearly. Light humor focuses on teaching fiction



through satire, introducing the characters of characters, and teaching the truth in life through the imagery of the protagonist.

We know from history that from the 11th-12th centuries to the 14th century, when the waterway along the open sea was opened, "Jipek Joly" (Silk Road) transported various valuables on camels, which were considered "ships of the desert" to China, India, Arabia and Europe, which gave them such a name.

-Ha' t yeler, t yeler,  
Duzi n qayda t yeler?  
Balqan tawdi n basında  
Balıq oynar tusında  
Jemısım jerge t gildi,  
Jer jusanın berdi.  
Jusandı qoy a berdim,  
Qoy qoshantayın berdi.  
Qoshataydı qonaqqa berdim,  
Qonaq qamshısın berdi  
Qamshısın k lge tasladım,  
K l s wregın berdi  
S wregın  az a berdim  
 az m yegin berdi [4. p.61].

The person who sings the song is talking to the camels. An artistic, convincing understanding of the interconnected system of nature is expressed in relation to the child. The method of explaining units of the surrounding world, objects, embodied in the language of animals, birds in oral folk literature, is especially widely used in expanding, developing the horizons of children.

" welemen-d welemen" - this song is also popular among the people. This indicates that Arabic and Persian became the norm of the literary language until the 19th century. "Awelemen birinshi men, duwelemen ekinshi sen" is a word in Persian dedicated to teaching children to count in the usual way, if there are two, three, four children in a family, then they are spent opposite each other touching each other with bare feet and counting with fingers.

 welemen, d welemen  
Salqan iytti n sanı menen  
Qara qoydı n qanı menen  
Awez molla qayda ketti?  
- Duz a ketti.  
- Qashan keler?  
- Jaz keler  
Jaz kelmese g z keler  
P llem push  
Qashsan' qash.  
Sen tur,  
Sen shıq [4. p.50].

In this song, which is sung with the game, children learn that they have nine, or the number of toes, the spring season in which Awez Mulla competed last season, and that there are four seasons in a year. Our ancestors who lived before us in the

past, using examples of the literary word, wisely brought up their descendants, prepared them for marriage, taught the secrets of life.

In oral literature, the plot of the song "fairy tale", dedicated to children, is close to the plot of the "Maqtanshaq pishi " (boastful cat) in the folklore of the peoples of the world. But in the song we see a plot close to a child's concept, psychology, aimed at logical thinking, which teaches unity and connections on the path of knowing the world, leads to knowledge through the thin paths of science.

Ertegin erde boladı,  
Qula ım kelte boladı,  
Tırna jasawıl boladı  
H kke biydumaq boladı.  
Ol k nge qarap sawal beripti:  
- K n sen neden k shlise ?  
- Men k shli bol anda bult basarma edi.  
- Bult, sen neden k shlise ?  
- Men k shli bol anda jawın teserme edi?  
- Jer, sen neden k shlise ?  
-Men k shli bol anda tıshqan teserme edi.  
Tıshqan, sen neden k shlise ?  
- Men k shli bol anda pıshıq alarmı edi.  
-Pıshıq sen neden k shlise ?  
-Men k shlimen, k shlimen,  
Aya ımda zerli gewısh,  
K nde mı n tıshqan sewısh [1. p.16-17].

The song conclusion ends with a boastful feline bragging. In the song, a comparison of the forces of nature, their modest arrangement appears as an event of artistic poetics. The bright light of the sun, giant black clouds, rains, endless expanses understand that in understanding the earth, they have their own simplicity, interconnectedness. In oral folk literature, this song "fairy tale", thanks to its skill in creating images that reflect the amazing nature, has become an action-packed means of education.

The song "Hakke qayda" (Where forty) is also a song in the form of a dialogue in which children raise their voices and sing it through a verse in a disciplined manner with the characters. The appearance of the song associated with the magpie is also due to the fact that the prologue is made from the character of this bird, which revolves around people, around children, and it summarizes such views on how to set a goal correctly, not to be influenced by people like a magpie.

The song answers the questions:

- H kke qayda?  
- Uyasında.  
- Ne qılıp atır?  
- Keste tıgıp atır.  
- Kestesı qanday?  
- Alaqanday.  
- D rwazanı n awızı qaydan?  
-  te beri n bunnan.  
- Neshe atlasam  temen?





- Eki atlasañ óteseñ.  
 - Bir nan jeyseñbe?  
 - Jartı nan jeyseñ be?  
 Bır nan jeymen.

Al onda basla [1. p.14]

Songs dedicated to children in folklore, accompanied by poems, carry a definite and educational meaning. This shows that creativity came from folk wisdom. Songs that are still meaningful to children throughout their lives serve as one of the main teaching aids. Among oral folk literature, there are also songs dedicated to children in a small form, in a way of narration, in the form of light humor.

Atı shawıp baratır  
 Eri awıp baratır  
 Suwga kelgen qızlardıñ  
 Kulkısı qısıp baratır [2. p.86].

Aspandağı juldızlar  
 Ay bolaman deydi-yar  
 Zulayxanıñ apası  
 Qız bolaman deydi-yar [2. p.29].  
 Shaq shağala shağala,  
 Japtıñ boyın jağala,  
 İlay suwda balıq bar,  
 Alalmaysañ shağala [1. p.15].

These songs are taught to children by adults. Children recite it by heart. It is sometimes said that the children of both sides compete, reciting poetry, who knows how many songs. In games and in children's poems:

“Aspannan pıshaq tústi,  
 Pıshaq fashistiñ ústine tústi.  
 Fashist ólemen dedi.  
 Saldat kómemen dedi”

These are words of curse pronounced against fascism, uttered from a child's language, describing the period of World War II in modern history. The songs of educational significance include adults who describe the consequences of a war that does not tear the child apart, giving rise to an anti-war character.

The wise people arose in the family even when raising a child with a speech impairment, especially speech, in the genre "Jan'iltıpash" (proverb), which was carried out through rhyming verse words, repeating them with the help of exercises in the language. Such material, fixed in a special form, teaches you to pronounce letters and words correctly and clearly, and forms in the child the skill of repeated repetition of words. Song lines are expressed in rhymed form. The language of children often has difficulty pronouncing consonants such as R, S, T. Therefore, more often there are sayings in which these sounds are combined. In raising children with speech impairments, the people skillfully use samples of oral literature and sayings.

1. Ayır atırdı júk qartaytar  
 Semiz qoydı may qartaytar

Úy qartaytar, búy qartaytar.

2. Qırda qırıq qırğawıl,  
 Qırıq qırğawıl ishinde,  
 Qırıq jıl qısır qalğan,  
 Qızıl qıl quyırılı qırğawıl.

3. Esiktiñ aldı qara barağ,  
 Qarabaraqtıñ ar jağı,  
 Qara qarabaraq,  
 Hámme qara qasqa baspağın,  
 Qarabaraqlandıрмаğa aparatır,  
 Mende qaraqasqa baspağımdı,  
 Qarabaraqlandıрмаğa aparatırman [1, p.8]

During the religious holidays, the people perform children's songs in the genre "Aytym" (legend), which are performed on the New Year holidays - Navruz.

Aydar, Aydar  
 Qırmanım tástı  
 Áwmetim astı  
 Qollaygór bizdi

Children were taught songs that have a poetic form, containing such expressions that are necessary at all times in a person's life, such as happiness, friendship, state, desire. For example: in order to cleanse his grains in autumn, asks Aydar, who is considered the god of wind, to give him the wind:

Men apamıñ tunğışiman  
 Qazan qırğış, qırğışiman,  
 Jawma kúnım, jawma! [2, p.42]

There is a popular belief that the one who gives birth to the first child will accept such a wish. On this basis, the people, performing songs of the legend both for themselves and for children, were brought up in faith in God the Creator. One of the legends that is performed on religious holidays is Yaramazan. The term of this song called "Yaramazan" refers to religious concepts at the beginning of the month of Ramadan, when people wish good intentions, when pronouncing these wishes, "Ya" is a sound that gives additional meaning to the word Ramazan in the introductory form, that is, language is the word marked at first sight, which gave rise to the word "Yaramazan". Ramadan, according to the religious understanding of our people, is a holy month. On one moonlit night of this month, there is an omnipotent night. It is believed that if someone sees the almighty night, he will be happy for the rest of his life. People fast in the month of Ramadan. With good intentions, the children recite the Ramadan songs.

Qazanıñ qaqpaqlı bolsın,  
 Sıyıñıñ baspaqlı bolsın,  
 Paraxat balañız úylenip,  
 Úyiñızde gúmbirlegen toy bolsın [2, p.43-44].

Yaramazan aytıp keldi esigiñe,



Qoşqarday ul bersin besigirne  
Çarezsizlik dâwirinde erkin jasap,  
Qıdır darıp dâwlet bersin nesıybeñe.  
Yaramazan! [2, p. 107] - children enter the city and say good wishes. At the Navruz holiday, children, along with many folk poems, sing songs.

Jılağan kún joq bolıp,  
Quwanğan kún kóp bolıp,  
Bawır pütün, bas aman  
Jekere bergey Nawrızğa [2, p. 46].

The content of the songs of the legend is enriched by the wishes of the folk, ethnic and cultural nature, significant for humanity with the development of society, under the influence of the development of spiritual and life values in the minds of the people. Children, overshadowed by joyful feelings, are not limited only to games and songs. It influences the upbringing of children by spiritual, national traditions. Young people who have received such an upbringing from a young age will grow up in generations capable of ensuring the well-being of the people in the older generation.

"O'tirik o'len" (False song), widespread in children's life, have an impact on the development of the child's consciousness at the symbolic level. The creation of false songs in oral folk literature is to teach children resourcefulness, eloquence and eloquence on a given topic - a lie.

Tuttım bürgeñiñ anasın,  
Tutqa bayladım tanasın,  
Qosqa qostım jupqanasın,  
Jer súdıgar etpedimbe?  
Bır bürge tepti dizeme,  
Keldım altı ayda özıme,  
Inanbas adam sózıme,  
Altı ay kesel jatpadımba? [1, p. 17].

False songs take a place in children's songs as the first elements of the art of eloquence, directing the child to a correct understanding of the world around him, knowing it with the help of artistic words. Whatever type of samples of oral folk literature we take, you will witness their rich content. Each of them is a masterpiece that is most actively used in the education of generations. In folk life, the wise words "education" have always been used - from cradle to grave. The upbringing of younger adolescents is exclusively collective in nature, going beyond the family environment. In whatever period the Karakalpak people lived, young people, who gave priority to human upbringing, did not limit themselves to adult and children's games and songs. Heroism, openness, which belong to major epic genres, listened to the epics performed by jirau and bakshi. The artistic work of the talented, creative, executive jirau and bakshi was very influential and served as the main means of spiritual education of the people. Before jirau started a big dastan, until the people gathered completely, he tried to educate the

younger generation by telling significant stories. For example:

Ağañ, mıñ bolmasa,  
Arğa shappaq ne payda,  
Jan kúyeriñ bolmasa  
Jawğa shappaq ne payda.

Bilegimde kúshım bar,  
Batırman dep maqtanba,  
Baxıt qondi basıma  
Úlkeydım dep maqtanba,  
Dún'ya jıyıp úyırñe,  
Kórkeydım dep maqtanba,  
Kóp maqtanğan bolmaydı  
Sózdiñ shıñın aytqanda [1, p. 26-27].

The influence of such didactic terms is very strong, indicating the right path for a person who made a mistake. There is a custom among the people to decorate various joyful events in the family with wedding ceremonies. In such wedding ceremonies, national customs and ceremonies, known as "Bet ashar" (Opening the face), when the bride opens her face and greets her close relatives and parents, take a wide place. This tradition has a deep educational image in its content.

Dâwlet bolğay úyımız,  
Sâwbet bolğay úyımız  
Kelinshek kelse awılğa  
Shad bolar kewıl kúyımız,  
Xızmette bolar kún-túni,  
Jası menen ğarrısı,  
El baslağan bıyımız  
Toyğa kelgen qonaqqa,  
Toldı búgin úyımız.  
Tegin emes bıraq bul,  
Hâmmesi senı sınaq tur,  
Qalay eken kelın dep  
Bır-brinen sorap tur  
Boyınsıp xalıq saltına,  
Iybe saqlap tartına  
Úlkenı menen kishısı  
Jası menen qartına  
Quwanışlı toyırña  
Jıynalıp kelgen xalqırña  
Jup sálem ber kelinshek!!! [2, p. 34]

Raising a young bride about the dignity of the family, the dedication of parents on the path of children, that kinship, love, respect are the most valuable qualities in a person's life, she decorates didactics with bright light, like a lantern on the way to creating a good family. This is a big factor pointing to the popular wisdom of how to bring up a bride who begins to build a new family. The reason is that she is the new bride, the mother who feeds the family, extends life by creating tomorrow's family members. The mother is the person responsible for raising the child in the family.



## CONCLUSION

Examples of oral literature describing the rich history of our people, folk pedagogy, ethnopedagogy, everyday life, life experience, views on justice and injustice of national culture, there are treasures that can serve as the basis for human education [3]. These are fantasies that run counter to normal life events and science. "Fairy tales-proverbs for good" - from artistic images on samples of oral literature to artistic details that affect a person, which can give him fair and correct decisions in conclusions.

## REFERENCE

1. Tajimuratov A. *Karakalpak folk pedagogy*. - Nukus: Bilim, 1996. - 140 p.
2. *Karakalpak folklore. Many volumes. Vol. V. Karakalpak folk songs*. Nukus: Karakalpakstan, 1980.
3. *Ethnopedagogy of the Karakalpak people. Collection*. Nukus: Bilim, 1995. - 104 p.
4. Tajimuratov Á. *Karakalpak folk pedagogy*. Nukus: Bilim, 1996.



# AN ICONOGRAPHY OF STIGMATIZED EXISTENCE: EFFECTS OF PANDEMIC COVID-19 AND LOCKDOWN ON MENTAL HEALTH

**Tanmoy Mandal**

Department of English, Bankura University

## ABSTRACT

*The focal point of this paper is to highlight the psychological reasons of loneliness of the people who are suffering from the fear of joblessness, homelessness and both physically and mentally ill. The present crises of Covid-19 have created an atmosphere of imprisonment where people try to appease their mind and manage to confine themselves from going outside. The immediate jobless crisis and financial insecurity of the marginal community are the major reasons behind having psychological stress and loneliness. This lockdown session due to covid-19 has enhanced an intolerable and miserable situation where people face the emergency problems of the unavailability of vehicles, ambulance services and doctors in the hospitals. Loneliness and lockdown are closely interrelated because both of these force us to the ground of confinement and social isolation. Loneliness is the state of being disconnected with the society. This confining and darkened state embeds a zone of irremediable singularity that brings a deep psychological impact upon all human beings. By following the qualitative method, this paper also focuses on the probable ways through which people can get some remedy from the suffocating state of stress, stigma and loneliness. Another important thing is that without making any physical communication with friends and outside relatives, we all human beings need to be accompanying ourselves through our hobbies, creative work like singing, dancing, writing stories or diaries etc. Lockdown is supposed to be a battling ground where we all are fighting together with the pain of aloneness against the pandemic disease Covid-19. We should remind this that we feel alone therefore we exist.*

**KEYWORDS:** - Pandemic Covid-19, Psychological Stress, Stigma, Loneliness, Isolation, Lockdown and Well-being.

## INTRODUCTION

The natural flow of human civilization is determined by the position of man as a social being. The greatest and most emblematic acts of human civilization are human generosity and mankind. Said Nadeem has provided a good opinion that "Mankind has observed various pandemics throughout the history where some of them were more disastrous than the others to the humans. We are observing a very tough time once again fighting an invisible enemy; the novel COVID-19 corona virus." (Nadeem, 2020) Man as a social being possesses to keep himself in a homo-social bonding and always prefers to stay in a social connection with the busy working life. This busy working life motivates human beings to go forward with the powerful ambition to achieve the goal. This motivation harvests an energetic mind inside us so that we can contribute our energy over the desired things with our deepest passion and complete dedication. All these things get collapsed when any outside factor comes to break off the chain of human ambition and dream

and the progressive process of human civilization. According to Said Nadeem "Human history is observing a very strange time fighting an invisible enemy the novel Covid-19 Coronavirus." (Nadeem, 2020) This natural flow of human civilization has been collapsed by the pandemic disease Covid-19 and its violent impact. It has already devoured the entire world with its rapid and wide spreading speed. We, human beings always stay in a social contact but this time we need to break off this physical communication by maintaining social distancing for our well-being. For this reason, the Government of India has announced lockdown from month to month consecutively and also has taken all the fundamental and necessary steps to face the challenges and threatened atmosphere caused by the impacts of Covid-19. The situation can only be overcome, with the support of the people, from the rapid and wide spread of the Corona virus.

The given word "stigmatized existence" in title is used to refer to the unwanted disgrace attached to something that is socially unacceptable. We all





have the pressure or disturbance of the impacts of covid-19 that have changed our normal social living communication system. This present condition of our "stigmatized existence" pushes us into a critical crisis of global economic downfall, social communication and other social activities. The patients who are infected by corona virus and who are sent to the isolation are the most victimized ones of stigmatized existence because of their excessive fear, nervousness and their detachment from their family members and society. Due to the lockdown and self-safety from getting affected by the pandemic disease, we are compelling ourselves to be confined at home. We all are deeply concerned about the horrible effects of the present condition because of the huge crises of joblessness, homelessness (due to natural hazards like flood, violent storm) and unemployment. All these things have brought a psychological threat that fills our mind with stress, stigma and loneliness. Lockdown and loneliness have a very close connection because loneliness creates due to the daily pressure of financial insecurity, global economic downfall which grasps our mind during the lockdown session. This corona virus outbreak has not only destroyed the chain of human civilization but also disrupted the global economy. A research study has analyzed a content on the mental health of rural and urban students: "With the unanimous response of increased awareness about mental health, the responses to reaching out to a mental health professional vary. Rural students seem to be less agreeable to reach out to a mental health professional as compared to the urban population, which may be attributed to the lack of awareness about mental health." (Moghe, Kotecha, & Patil, 2020) We all are humans and it is natural to get stressed and stigmatized because of the fear of present condition, pressure of study and examinations, job crisis, unemployment and financial insecurity etc. The unavailability of the provided patient beds, doctors, ambulances in the hospitals and the emergency vehicles has enhanced the present situation more problematic and dangerous. Many NGOs and social workers have come forward with their humanistic responsibility to assist the poor, needy, migrated and working-class people and the marginal community by providing food and water since the situation becomes more critical and dangerous. These all kinds of people are going through a huge psychological stress because of their victimization to the present condition and the fear of losing jobs. Most of the people of marginal community are daily workers who earn money by doing their daily jobs. We all have stress and pressure. When we worked at any industry, private company, any private school or anywhere, we had both stress and pressure. But now we all are confined and engaged with the pressure of job crisis and psychological suffering because we are bored enough to continue the prison lifestyle. This complete

binary engagement or belongingness has created the stress between the employment and unemployment, association and dissociation, attachment and detachment. Though we all should keep hope to beat the present circumstances and achieve a new world.

## REVIEW ON EXISTING LITERATURE

It is known to all that covid-19 has dwindled all the expectations of human civilization. Millions of people have faced a huge loss in their economic grown up condition. A lot of researchers have been done on this topic. But this paper is highlighting a new emphasis on the stigmatized existence and this is caused by the effects of Covid-19. A thesis paper written by Vasiliki Tzouvara "Self-Stigma Loneliness and Culture among Older Adults with Mental Illness Residing in Nursing Homes" is about the inter-relationships Self-Stigma and loneliness and culture among the older adults and their mental distress. Another important paper by Sabine Rohrmann is "Loneliness is adversely associated with physical and mental health and lifestyle factors: Results from a Swiss national survey" which manifests a clear concept on loneliness. To analyze the present condition about the mental illness and present crises, the paper seeks some information from WHO website via internet.

## METHODOLOGY

A research method is a systematic method by which a research is conducted. There are two types of researches-- qualitative and quantitative. This research paper is based on qualitative research because it is done through content analysis. This research carefully finds out the descriptive responses to each question. Research methodology is the specific way or technique used to identify which process has been followed to analyze information of a topic. To demonstrate this topic a descriptive method has been used because to emphasize on the written analysis of this paper is more important rather than judging the argument.

## OVERALL VIEW ON COVID-19 AND HEALTH DISORDER

The pandemic caused by covid-19 has triggered a global crisis and changed the ways of our living and forced in an atrocious condition. This unmitigated and measurable condition has put us in a state of home imprisonment from where we become aware of the effects of covid-19 and also get the news of the misery of the marginal communities. The forceful home confinement and the downfall of global economy have brought a long mental stress over us and made our existence more stigmatized. It is true that "Lockdown stressors include separation from family and friends, loss of independence, doubts about the virus's spread, lockdown length,



resentment, monotonous lifestyle, potential scarcity of essential goods, lack of accurate information, monetary loss, and stigma” (Sundarasan, Chinna, Nurunnabi, Baloch, & Sukayt, 2020) We all are prepared to take any necessary step to assist our neighbors and relatives and others in the times of need. Besides having the deep pain of home confinement and social isolation we all have the mental pressure of financial insecurity and joblessness and other possible dangers of getting affected by so many diseases. As we are social being, it is our duty to hold mankind and we should stay beside the needy people by maintaining our temporary and necessary physical distances. This social contagion has created a profound and pervasive impact on every aspect of our existence; though this unavoidable thinking of danger is a treat that revolves in our mind all the time. Consequently, psychological tensions gather in our mind in the form of stress and stigma and put us in the state of depression loneliness and frustration (due to the remembrance of the past). In this time, we give up hope because certain particular wishes, hope and pleasurable moments are no longer able to come true and heal our mind with love and charity. We all look for the redemption from the unavoidable crisis created by the pandemic disease. There is every reason to get despaired and depressed under present circumstances and the lack of dignified political leadership that have put us in the state of self-isolation.

### **LONELINESS AND MENTAL STATE**

Loneliness is the belongingness to the self, though a compelling thought that makes us suffer in the midst of all detains our mind with the pain of aloneness. It's the foundation of staying away from true relationship, though it itself seeks for true love in the hope of getting mental satisfaction and true consolation. A darkened state, it is that puts forward an errand of non-confidence, unreliability and mistrust. According to Sabine Rohomann "Loneliness is a common, emotionally distressing experience and is associated with adverse physical and mental health and an unhealthy lifestyle." (Rohrmann, 2017) Loneliness is inescapable but necessary; it transfigures into a defenseless longing. It can be a prison from where we imagine the previous outer world but we can't inhabit there. Our present confined situation makes us feel like a prisoner who is incarnated in a prison. It's a bodily and heartfelt ache that fathoms our ability to tolerate aloneness; it is possible to human beings because of our capability to imagine the past events but no other creature does have this ability. During this lockdown session we spend time at home and make our home an imagined world where we can memorize our old happy moments with our closest ones. Animals may also feel alone when they're instructed to follow a

particular way, move affectionately with them who are of their kind but human beings demand only that specific life that they may be missing.

Loneliness is the gravitational field that grasps and keeps us to put in the essence of its isolation. At this moment our soul gets dissected and we need someone to solace and relieve us by magnifying those memorable moments. An invitation to the vulnerable and helpless imprisoned world is made to us that gradually fill the ground of our mind with the sense of impossibility over any work. Loneliness can also give birth to courage that helps us create an identity to ourselves. Each one must feel the pain of loneliness that may give birth to any creative work. Sometimes we want to be loner (one who avoids company) to listen the voice of our own and give real attention to the voice of our hearts. To allow ourselves to be alone is an attempt to face the truth of our irremediable singularity; as if we are made to belong in this state. We feel alone, therefore we exist.

### **STRESS AND MENTAL DISORDER**

Stress is a mental pressure or disturbance that is caused by some unwanted violent condition. Stress is a mental response to the self-belongingness that grasps one's attention over any pressure. We all have "Stress hormones (cortical, adrenaline and noradrenalin) prepare the body to fight or flee." Our "breath quickens, heart beats faster, senses are sharpened (sight and hearing), the individual become more alert, certain blood vessels constrict, which helps direct blood to the muscles and the brain and away from the skin and other organs." (Christos, 2015) The impact of loneliness stress and self-isolation imposed by pandemic situation puts an emphasis on the mental and physical health. A person whether a student, teacher, worker, man, woman, everyone has faced stress and is still facing stress in his or her own way because we all have different kinds of problems. The major reason of having stress is our excessive pressure to achieve the target or aim and for this we come in a pressure of acquiring the aim. What external matter compels our mind to think excessively is called stress and the person who feels stress is called stressor. The rapid growth of industries, population, and pollution are the general reasons for the increase of stress. According to the psychologists, stress originates from any graceful work or event or the situation where we get entrapped. Many people get stressed because of having excessive pressure of unemployment which is a big issue in this pandemic time. Nowadays one of the biggest issues of stress is the fear of touch through which anyone can get affected with corona virus. This kind of stress is a challenge to keep ourselves protective. The life of loneliness and self-isolation imposed by covid-19 puts an emphasis on the mental and physical health.



The crisis through which we are going is unavoidable. It is unexpected that we shall always get a life that goes on in a smooth parallel way. The tidal waveform of crisis generates a new inescapable problem so that we prepare ourselves with our energetic mind to overpower them. We know that the pandemic situation is a curse to us but despite having problems, we should continue to deal with the forthcoming hazards as well as our psychological stress of suffering.

### **STIGMATIZED EXISTENCE**

Stigma is the bodily reflective response of a disgraceful threat. It is an unintended and unwanted fear of infamy or disgrace. The word 'Stigma' is actually used "In ancient Greece stigma was a mark or brand burned or cut into the flesh of people who were criminals or slaves." (Tzouvara, 2015) With this mark, it becomes easy to distinguish them. But nowadays stigma is used to refer to the mental illness that is viewed through our odd behaviors, lack of concentration over many works etc. It can be manifestly recognized through our bodily expression due to loneliness and depression excessive stress on job, study and other things. Stigma can be two types- Social stigma (A prejudiced attitude that creates mental illness) and Self-perceived stigma (Any Internal matter that makes one suffer from mental illness) But the present crisis due to pandemic covid-19 has pushed billions of people into a world of stigmatization. The major reasons of the stigma are financial insecurity, unemployment, family problems and personal problems and lack of understanding in any social matter etc. The consequences of stigma are serious and humiliating. Whoever suffers from the state of mental illness needs the support of someone who can understand the person and treat him properly with love. But in this paper the most notable point is our stigmatized existence that has brought a mental pressure or disturbance. This given image of "stigmatized existence" has created an iconography of our mental illness. As a result of this stigmatization and home confinement, we become surrounded by the mental state stress, loneliness and depression. Despite having all these problems, we are trying to overcome the situation so that we can revive the sense of well-being for mankind.

### **TOWARDS WELL-BEING**

The triggered action of Covid-19 has made all human ambitions and dreams stagnant and has injected the fear of death in our mind. Life is like a stream where water flows rapidly with its own speed but this speed becomes stagnant suddenly, we become motionless. "Prevention" is necessary to maintain social distancing and it is "the best practice in order to reduce the impact of Covid-19 considering the lack of effective treatment". (Fransesco Di

Gennaro, Damiano Pizzol, Claudia Marotta, Mario Antunes, Vincenzo Racalbuto, Nicola Veronese and Lee Smith, 2020) We all are confined in a state of home imprisonment and also going through the pain of Stress, depression and loneliness. To get over from this state we need to accompany ourselves with our hobbies, creative works like singing dancing and writing stories, poems diaries etc. It's hard to believe that we have to take the courageous step of getting close to us so that we can realize 'us' in a new form. We know that we all have different kinds of capabilities and abilities to do anything. It's necessary to think everything in an alternative way. It's an art to be imaginative to recognize our feelings. To eliminate our stress and loneliness we need to understand our mind and should think what kind of capabilities we have and we can highlight properly by staying at home. We all have our own way of remedies by giving importance to our needs and desires. We can meditate and do yoga classes and can enjoy the environment of our neighborhood. Meditation is important to calm down our mind in this crisis and even helps us to concentrate on reading and writing. Another important thing is that we can get a peer supporting group and share our experiences with our closest ones. The most profound form of conversation and deeper understanding with our inner mind can only be possible in this horizontal time of home confinement. It's natural to be lonely and get depressed in this time because we did not ever feel this kind of circumstances before. If we think in a broad minded way, we can see a lot of refugees and workers become homeless and deprived of their natural needs like food and shelter due to the violent natural hazards flood and Storm. In comparison to them our living condition is better than and their living. We as a community need to move on and our oneness with our heart's content of generosity and humanity.

We all have to be courageous enough to struggle against the besieging circumstances of covid-19; though we still did not get any hope to make our living ways better. The doctors, nurses, police and social workers are struggling at their best and put themselves in a horrible hazardous condition by doing their duties to keep us safe in this crucial circumstance. They are the gifts of bliss against all odds things in the greatest and most emblematic act of human generosity; their self-sacrifice and kindness over all human beings encourage us to live happily. We all keep our best wishes for them and also for making this planet safe.

### **CONCLUSION**

This paper highlights and unearths the psychological reasons and the probable remedies of stress, stigma, loneliness and depression. These are natural emotions and have played a crucial role in the journey of human evolution. We all are unique and



different in the way we think. We work for the well-being of the human civilization. The Government of India and the ministry of health and family welfare have been providing new policies and public awareness to influence people with the hope of overcoming the pandemic situation. They are trying their best to tackle different issues and problems imposed by Covid-19. Therefore, as a human being, we all should show our humanity by helping the needy and poor people at this crucial time because it's not possible for any government and NGO to look upon everyone. Another thing is that we need to meditate everyday so that we can calm down our mind and take reliable decisions in this pandemic situation.

## REFERENCES

1. Christos, T. (2015). *Loneliness and Its association with stress and psychopathology*. *ENCEPHALOS*, 25.
2. Francesco Di Gennaro, Damiano Pizzol, Claudia Marotta, Mario Antunes, Vincenzo Racalbutto, Nicola Veronese and Lee Smith. (2020). *Coronavirus Diseases (COvid-19) Current Status and Future Perspectives: A Narrative Review*. *International Journal of Environmental Research and Public Health*, 7.
3. Moghe, K., Kotecha, D., & Patil, M. (2020). *Covid 19 and Mental Health: A Study of Its Impact on Students*. *MedRxiv*, 6.
4. Nadeem, S. (2020). *Coronavirus Covid-19: Available Free Literature Provided By Various Companines, Journals And Organizations Around The World*. *Journal Of Ongoing Chemical Research*, 7.
5. Rohrmann, S. (2017). *Loneliness is Adversely Associated with Physical and Mental Health and Life Style Factors: Result from a Swiss National Survey*. *Plos One*, 1.
6. Sundarasan, S., Chinna, K., Nurunnabi, M., Baloch, G. M., & Sukayt, A. (2020). *Psychological Impact of Covid 19 and Lockdown among University Students in Malaysia: Implications and Policy Recomendations*. *International Journal of Environmental Research and Public Health*, 3.
7. Tzouvara, V. (2015). *Self- Stigma, Loneliness and Culture Among Older Adults with Mental Illness Residing in Nursing Homes*. In V. Tzouvara, *Self- Stigma, Loneliness and Culture Among Older Adults with Mental Illness Residing in Nursing Homes* (p. 24). Bedford, U.K.: University of Bedfordshire.





## A STUDY DURING COVID ON DIGITAL DEVICES DEPENDENCY & IT'S IMPACT ON HEALTH

Sajul Ramachandran<sup>1</sup>, J Saran Prakash<sup>2</sup>, Ron Soj Varghese<sup>3</sup>,  
Shaaheen Shareef<sup>4</sup>, Sreehari K.S<sup>5</sup>  
Shikha Upadhyay\*

<sup>1</sup>Forensic Science (Hons)Final year Department of Forensic Sciences, Jain (Deemed-to-be University),  
Bengaluru, Karnataka, India

<sup>2</sup> Forensic Science (Hons)Final year, Department of Forensic Sciences, Jain (Deemed-to-be University),  
Bengaluru, Karnataka, India

<sup>3</sup> Forensic Science (Hons)Final year, Department of Forensic Sciences, Jain (Deemed-to-be University),  
Bengaluru, Karnataka, India

<sup>4</sup> Forensic Science (Hons)Final year, Department of Forensic Sciences, Jain (Deemed-to-be University),  
Bengaluru, Karnataka, India

<sup>5</sup> Forensic Science (Hons)Final year, Department of Forensic Sciences, Jain (Deemed-to-be University),  
Bengaluru, Karnataka, India

**Correspondence** - \*Assistant Professor, Department of Forensic Sciences, Jain (Deemed-to-be  
University), Bengaluru, Karnataka, India

---

### ABSTRACT

The Covid -19 pandemic situation which is currently going on, there has been a huge surge in the use of digital devices in the youths and an unexpected percentage rise in the overall dependency on it. The digital devices have made our cash transactions easy and smoother. Earlier, we used to stand in queue for paying an electricity bill or transferring money from our account. But now with the help of internet and digital device we can transfer the money from our home to anyone around the globe. We can buy almost all things from the internet with the help of different apps and shopping sites for clothes, food, books, electronics etc. but these dependencies have negative impacts on life such as health issues and addiction to these electronic gadgets. Most of the teenagers cannot even think of life without mobile and these electronic gadgets is slowly decreasing the thinking capacity of the brain. The study aimed to conduct a survey on the effect on health using digital device in everyday life. However, the study has been conducted mostly on youngsters those who belong to age group between 18-26. The survey gathered 127 responses in total and the identity of the respondents were kept anonymous. The response of the audience was studied and examined carefully.

**KEYWORDS:** Internet effect, Electronic gadgets, Digital devices, Health issue etc.

---



## INTRODUCTION

Digital devices are becoming more widely used particularly by young people but little consideration is normally given to the health risks they pose ((Krishnan et al., 2017).

A new generation of children is being raised who lead device-driven lifestyles. Nowadays computers and other handheld electronic devices such as mobile phones, PSP, Game boy, etc. are becoming more of an essential requirement than luxuries, and our youngsters are inseparable from them. Digital devices were introduced to make human lives much easier and better. It is our duty by making life easy but at the same time these digital devices are a very bad influence also.

It also owns a deep impact on implementation such as healthcare where it influences the health behaviors of adolescents and others, especially eyes (Krishnan et al., 2017). The radiation from the devices would give a bad impact on the health. Then there is the bad posture. Due to the usage of devices anywhere at any time, we tend to forget to sit properly and use the device without any strain and thus giving strain to our neck, shoulder and back. Smartphones and smartwatches enable passive, unobtrusive ecological sensing that provides continuous measurement of individuals' behavior and physiology, such as sleep, social interactions, physical activity, electrodermal activity, and/or cardiac activity (Marsch, 2020)

Smartphones and laptops have become an irreplaceable communication tool in our daily life and many people keep their phones, their computers, laptops, etc. turned on around the clock 24/7. Generations nowadays are completely dependent on devices 24/7 since every single detail can be attained from a fingertip. This continuous usage of digital devices creates a lot of health hazards which are extremely dangerous in the long run.

## METHODOLOGY

The pilot study was aimed at studying the effect on health and their dependency so, a purposive sampling method was followed to collect information from individuals. The study was conducted using the online survey method with the help of Google Forms. The questionnaire used in this study is a structured one. The survey included 10 questions with multiple choices for the respondents to select appropriately. The majority of the students who all are taken poll were regularly using social media. The team members collected 127 responses in total and the identity of the respondents were kept anonymous.

## RESULTS AND DISCUSSION

Smart-devices have increased dramatically in popularity over the past five years but much remains to be understood about the impact these devices have on mental health. This study investigated the influence of smart-devices on users' mental health, specifically smart-device use and smart-device involvement (Joshua Harwood, 2014).

In the previous year's research, it has been shown, most adolescents used an electronic device in the hour before going to sleep. Some gender differences emerged, with more boys using game consoles, whereas girls reported higher use of cell phones and Mp3 players (Mari Hysing, 2015).

With reference to the conducted poll and from our analysis of the poll, it can be noted that:

Responses showcased a trend that mainly involved the youth, ageing from 18-26, being majority (98.43%) of the total number of respondents. The least number of respondents included from the age group of below eighteen (1.57%).

The respondents belong to two categories,

1) College students (77.17%) and 2) School students (22.83%). Population reported using mobile phones are 79.52% and the rest 20.48% are using other digital platforms daily.

With respect to the students who all are playing games are 55.91% and other 44.09% are voted that they are not playing games daily.

Out of this 61.43% are playing games for less than 1 hour, 25.98% for 1-2 hours, 8.66% for 3-4 hours and 3.93% for 4-5 hours. The using of phones for online classes have increased by a percentage of 86.62% and the rest 13.38% does not have online classes. 30.73% voted they have online class for 1-2 hours, 24.40% voted for 4-5 hours, 17.32% have 3-4 hours, 18.11% have 5 and above hours and 9.44% have classes for a period of 2-3 hours.

87.41% of the students are a regular user of mobile phone and 12.59% are not that much addicted.

According to one local addiction and recovery program which treats problematic use, too much digital technology use can lead to a disinterest in physical fitness, poor nutrition and hygiene, sleep deprivation and chronic fatigue, emotional distress, depression and anxiety, and relationship difficulties (Selvarajah Krishnan, 2017).

According to the polls, 39.38% of students states that they don't get proper sleep because of using mobile phones and 23.62% have agreed that they are able to sleep properly and 37.00% students voted they don't know. Majority of students have health problem such as headache, back pain or neck pain while using phone.

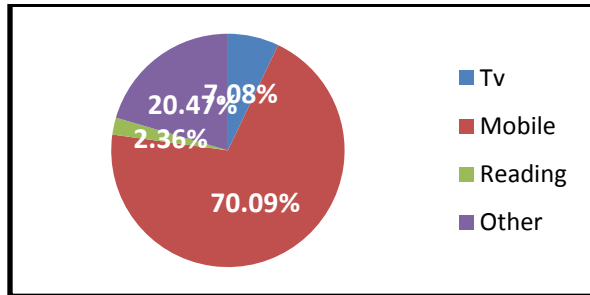
The epidemiological evidence that exposure to radio frequency fields might have an adverse effect on the health of people is examined in the report with emphasis on the



risk of brain cancer from the use of mobile phone handsets (Z J Sienkiewicz, 2005).

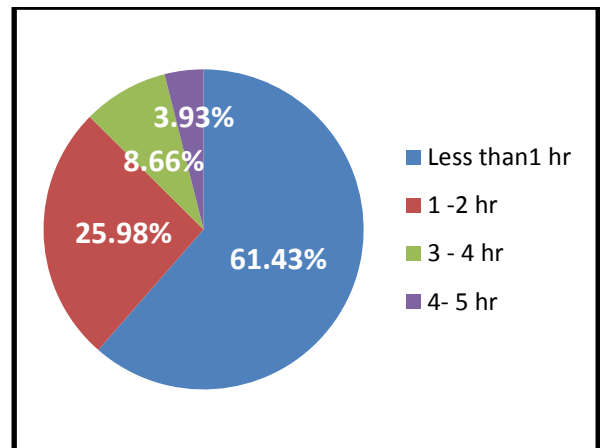
The following figures showcase the results of the conducted survey:

**1) How do you mostly spend your free time?**



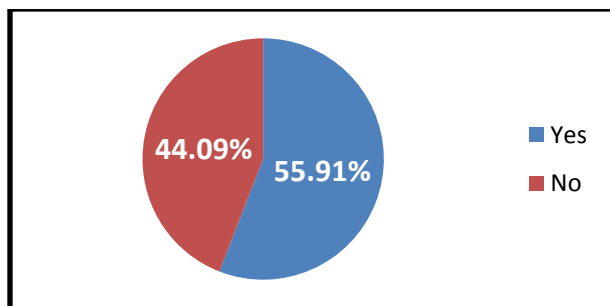
TV - 7.08%  
 Mobile - 70.09%  
 Reading - 2.36%  
 Other - 20.47%

**3) How many hours do you play games in mobile?**



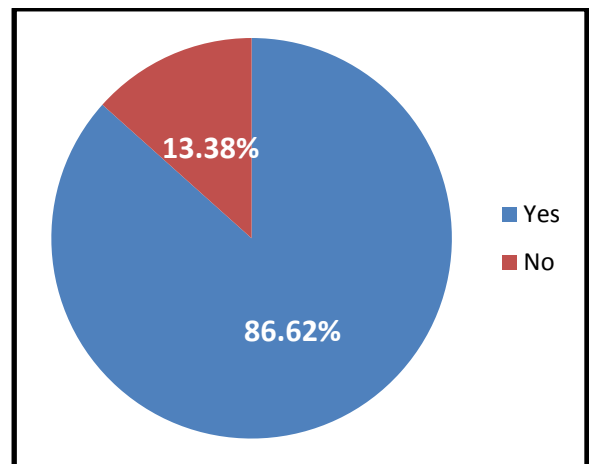
Less than 1 Hour - 61.43%  
 1-2 Hour - 25.98%  
 3-4 Hour - 8.66%  
 4-5 Hour - 3.93%

**2) Do you play any games on pc or mobile?**



Yes - 55.91%  
 No - 44.09%

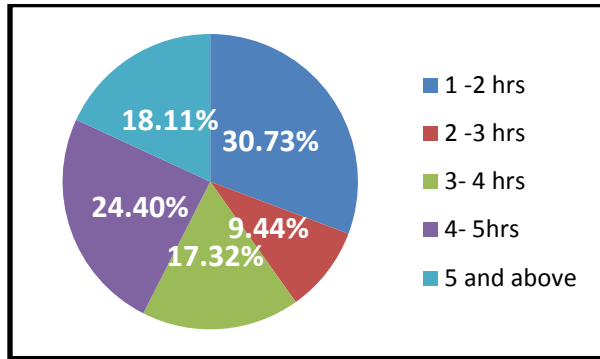
**4) Does your school or college conduct online class?**



Yes - 86.62%  
 No - 13.38%

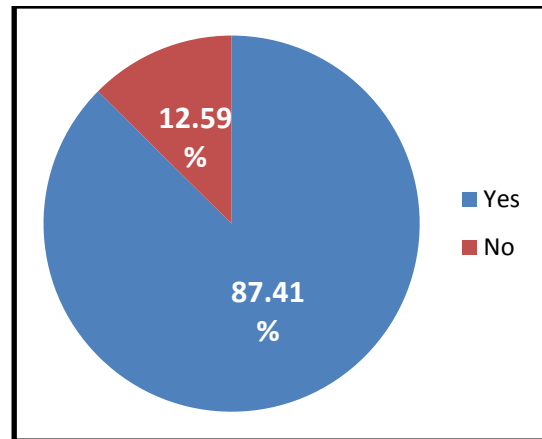


5) How many hours of class are conducted by the teachers?



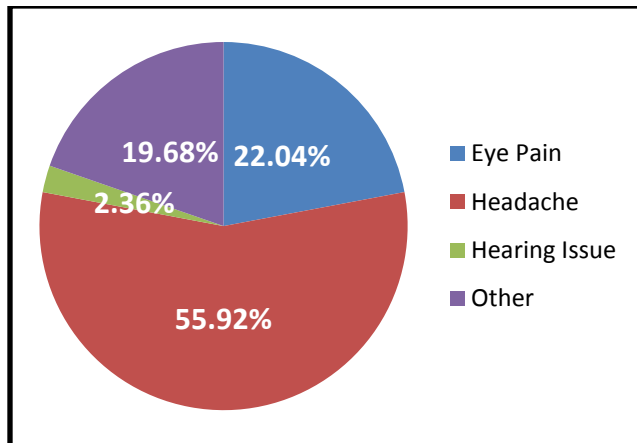
1-2Hour - 30.73%  
 2-3Hour - 9.44%  
 3-4Hour - 17.32%  
 4-5Hour - 24.40%  
 5 and above - 18.11%

7) Are you a regular user of digital device?



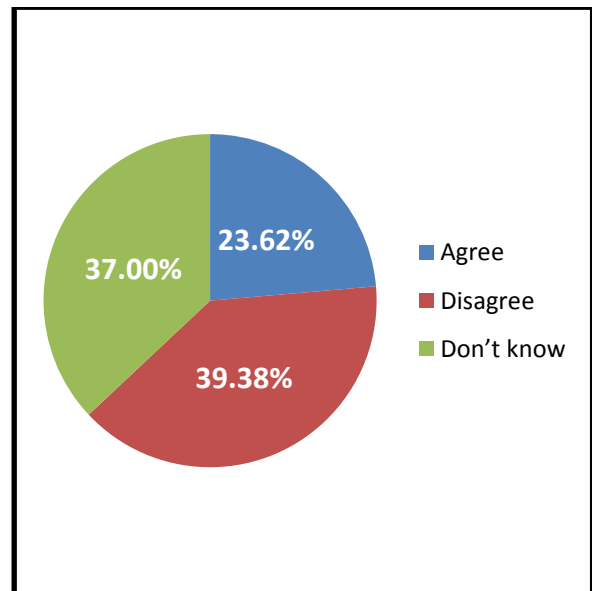
Yes - 87.41%  
 No - 12.59%

6) What are the health issues you face while using pc or mobile for long time?



Eye Pain - 22.04%  
 Headache - 55.92%  
 Hearing Issues - 2.36%  
 Others - 19.68%

8) Due to the frequent use of digital devices as seen in youngsters, do you think they are getting enough sleep which is normally recommended?

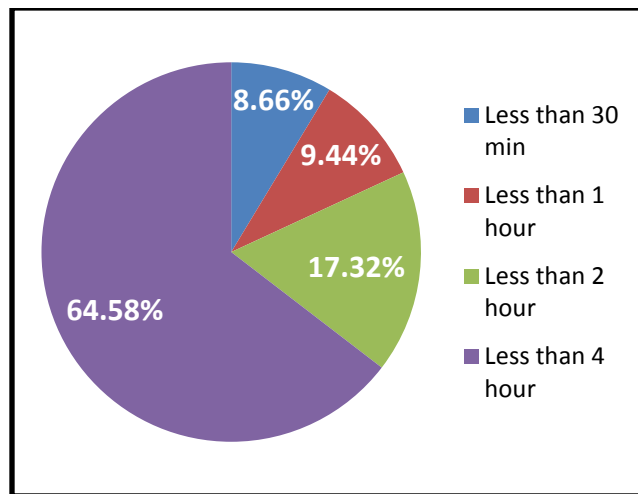


Agree - 23.62%  
 Disagree - 39.38%  
 Don't know - 37.00%





### 9) How long can you be without using a mobile/pc?



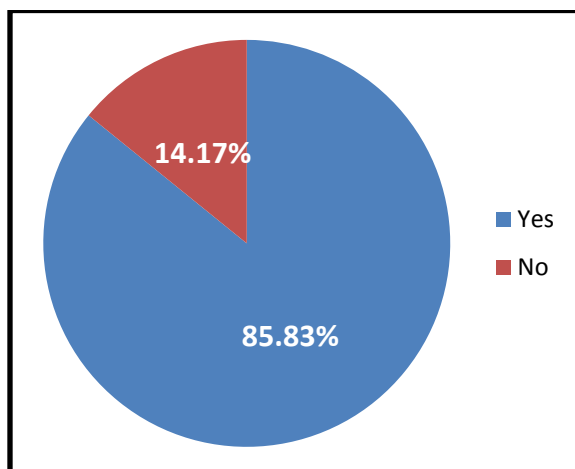
Less than 30min - 8.66%

Less than 1hour - 9.44%

Less than 2hour - 17.32%

Less than 4hour - 64.58%

### 10) Do you think your mobile use has increased in these lockdown time compared to previous period?



Yes - 85.83%

No - 14.17%

### CONCLUSION

In this inescapable modern era of digital devices and its technological advances, it is clearly evident in the prepared report of the survey conducted that majority of the individuals from age group of 18-26 are frequent users of digital devices of some form. Technological developments are largely variable, and the effects also depend on the type of device, the type of use, the amount and extent of use, and the characteristics of the adolescent or youth. In the recent times due to the pandemic (COVID-19) situation more time is spent on digital devices be it for attending online classes or surfing the net or using social media. The intensive usage of digital devices is creating immense health complications on the youth of this generation.

The health complications range from eye pain, headache, neck and shoulder strain, back pain (due to the posture at which they use the device) and then various other complications. At such a young age majority are facing these health complications which are usually seen in aged people. Even their sleep patterns are highly disturbed due to the usage of digital devices. Majority are claiming that they don't get sleep at all due to the intensive usage of digital devices. It is necessary to implement and benefit from the principles of balanced nutrition, quality sleep, adequate physical activity, and positive social interaction for healthy growth and development by making plans according to the age, health status, character, and level of development of the young adults.

Those individuals that are experiencing these health complications should improvise in their usage of the digital devices and to reduce their screen time. The total technology usage time during the day or night time (e.g., watching television and playing games on computers, tablets, and mobile phones) should be limited to 1-2 hours or 2-4 hours max. It is better to use the time productively in order to keep them busy and to avoid using the devices at all and only when necessary. Nowadays everyone is having work-at-home situation and it is evident to implement ergonomics is more for move health risk factors that lead to musculoskeletal injuries and allows for improved human performance and productivity.



## REFERENCES

1. Krishnan S, Zakaria A, Khalil F, Jofree S.(2017). *The Effect of Electronic Device on Human Health. Management, Vol. 7 No. 1, 2017*, Retrieved from <http://article.sapub.org/10.5923.j.mm.20170701.05.html#Abs>
2. Hysing M, Pallesen S , Stormark KM, Jakobsen R, Lundervold AJ, Sivertsen B (2015, February 2). *Sleep and use of electronic devices in adolescence: results from a large population-based study*, Retrieved from <https://bmjopen.bmj.com/content/5/1/e006748>
3. Sienkiewicz ZJ , Kowalczyk CI. (2005,January). *A Summary of Recent Reports on Mobile Phones and Health (2000-2004)*, Retrieved from [https://webarchive.nationalarchives.gov.uk/20140714124816/http://www.hpa.org.uk/web/HPAweb&HPAwebStandard/HPAweb\\_C/1253114170459](https://webarchive.nationalarchives.gov.uk/20140714124816/http://www.hpa.org.uk/web/HPAweb&HPAwebStandard/HPAweb_C/1253114170459)
4. Harwood J,Dooley, J J, Scott, A J., & Joiner, R. (2014). *Constantly connected – The effects of smart-devices on mental health. Computers in Human Behavior*, Retrieved from <https://www.sciencedirect.com/science/article/abs/pii/S0747563214000661#>
5. Marsch, L. A. (2020). *Digital Health and Addiction. Current Opinion in Systems Biology*, Retrieved from <https://www.sciencedirect.com/science/article/abs/pii/S2452310020300081>



# SMART ROBOTIC SHOPPING CART USING RADIO FREQUENCY IDENTIFICATION

<sup>1</sup>DR. Siva Subramanian S, Ph.D. <sup>2</sup>Shivanjali Sivakumar, <sup>3</sup>G. Soniya

<sup>1</sup>HOD, Computer Science and Engineering  
Dhanalakshmi College of Engineering, Tambaram, Chennai -601301

<sup>2,3</sup>UG Scholar, Department of Computer Science and Engineering  
Dhanalakshmi College of Engineering, Tambaram, Chennai – 601301

---

## ABSTRACT

*The IoT has already started working its way into retail stores, and technologies will continue to disrupt the traditional retail process in the coming years. From a retail perspective, IoT takes on greater importance with the prospect of sensors that can enable their enterprises to take advantage of every possible piece of shopper data available to them. The growth of IoT technologies, opportunities, and use cases which are now available have made this even more compelling to retailers. This paper proposes a smart way for people to bill their products while they shop and it provides an android audio assistant for people to navigate in big shopping malls.*

**KEY TERMS:** RFID, Arduino UNO, DC motor, Bluetooth module, Driver IC, IOT(NodeMcu).

---

## INTRODUCTION

Sensors are electronic devices that can collect information from the surrounding environment. Wireless Sensor Network (WSN) is used to interfacing of multiple sensors to work together and share collected information wirelessly. Isolated systems are less valuable than networked systems which generate more intelligent and autonomous applications. A wide range of information can be collected, when the coupling of the wireless sensors with networked systems. IoT is directly or indirectly tightly coupling of communication network and sensor network where the data management and data processing achieved by monitoring these processes intelligently. The sensors and actuators have an important role in IoT that enables us to communicate with the physical world. It consists of three terms physical, smart and connectivity which defines how smartly the sensors, microcontrollers, microprocessors and physical devices such as actuators which connect wirelessly or wired to manage information with other electronic devices. IoT enables people to manage their lives, business in effective manners and provide fundamental changes to the world that can completely transform business and industry. The potentialities offered by the IoT make it possible to develop numerous applications that belong to the industry of aerospace and aviation, automotive, telecommunication, medical, healthcare, Independent living, Pharmaceutical, Transportation, Manufacturing, Retail, logistics and supply chain management. The most important objective of IoT is to monitor individual objects and environment wirelessly. This introduces electronic tags attached to individual objects. When these tags become in the range of reader it reads the stored information of object wirelessly which is known as RFID technology. RFID plays an integral role in the applications of IoT. It consists of three components such as RFID tags attached to the object that contain identity or data about an object, RFID reader that read the data from the tags and central processing system that perform communication in between RFID system to other electronic devices. It emerging a revolutionary effect on a wide range of applications like aircraft maintenance, anticounterfeiting, health care, baggage handling, and supply chain management.

## PROJECT DESCRIPTION

### Existing system

- ✓ The present process in Shopping Malls are done with the help of Barcode scanner. Vendor scans the product through the barcode scanner which is a time consuming process and Customer will have to wait in long queues.



- ✓ The existing system uses the Quick Response code (QR code) technology which is implemented to identify the product. The audio instructions can assist them within the grocery store supported by real-time situations.

### Proposed System

- ✓ Our proposed method introduces automatically moving trolley. The trolley has a robotic structure. The proposed method has RFID tag and reader, Bluetooth module, Driver IC, IOT and DC motor.
- ✓ The DC motor is attached to the trolley, which is used to move the robot to reach the exact location of the product in the shopping mall. The Bluetooth module is used to select the products. When the user selects any product through voice command it gives the command to the controller and make the robotic trolley to move to the exact location.
- ✓ The proposed system has the feature of automatic billing when a customer carries a trolley full of items through RFID tag and reader.
- ✓ All products have unique id, with that code it will identify the product price and generates the bill automatically through internet.

## RELATED WORKS

### Electronic Shopping using Barcode scanner

A modern forward-looking product is the one that aids the comfort, convenience and efficiency in everyday life. In this paper, we discuss an innovative concept of 'ELECTRONIC SHOPPING'. The key idea here is to assist a person in everyday shopping in terms of reduced time spent while purchasing a product. The main goal is to provide a technology oriented, low-cost, easily scalable, and rugged system for aiding shopping in person.

### Smart Shopping cart with Automated Billing system

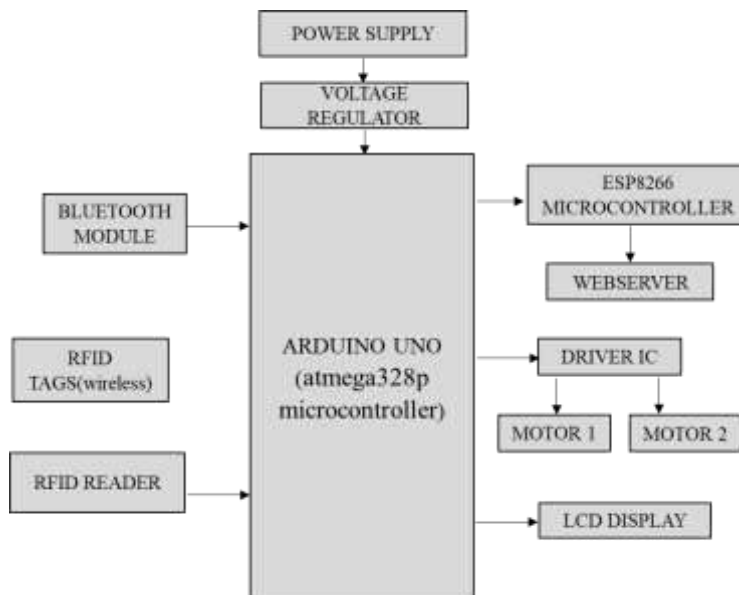
To overcome this, a smart way to shop in malls has been developed. Each product has an RFID tag instead of a barcode. The Smart Trolley features an RFID reader, LCD module. When a person places any product on the trolley, it is scanned and the product's cost, name, and expiration date are displayed. The total cost will be added to the final check out bill. The bill is stored in the microcontroller's memory. Once the purchase is complete, the purchase details are sent to the customer through the GSM module.

### Virtual cart: Novel approach for revamping smart shopping experience

Shopping at malls is a frequently carried out activity in. There can be a big rush at malls on holidays, weekends especially during special offers and discounts. Contrast to shopping in malls, people prefer online shopping to get required items through Amazon, Flipkart and Snapdeal etc., where they cannot have the look and feel of items unless they receive the delivery. So, to solve this problem we have proposed Virtual Cart, using which, one can overcome the complications of online and offline shopping by ensuring a better shopping experience.

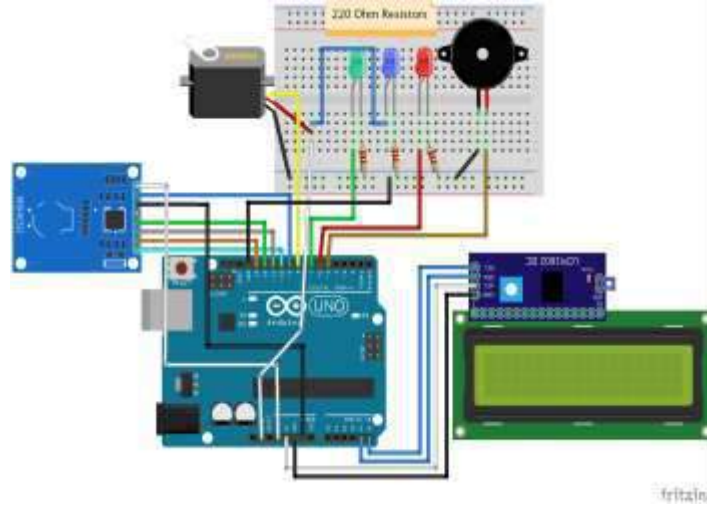
## HARDWARE CONFIGURATION

### Block Diagram

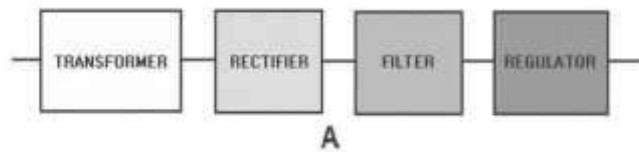


### CONNECTION DIAGRAM

### Interfacing RFID reader, Bluetooth and LCD display using Arduino UNO



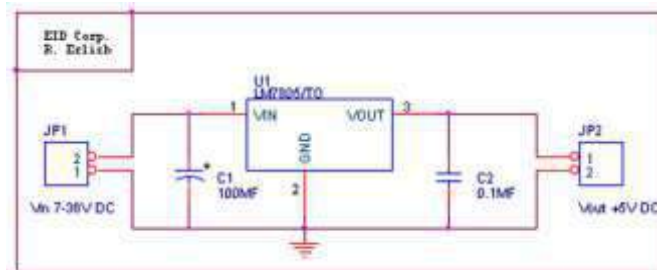
### Block diagram of a basic power supply



### Circuit description

This circuit is a small +5V power supply, which is useful when experimenting with digital electronics. Those transformers are easily available, but usually their voltage regulation is very poor, which makes them not very usable for digital circuit experimenter unless a better regulation can be achieved in some way.

This circuit can give +5V output at about 150 mA current, but it can be increased to 1 A when good cooling is added to 7805 regulator chip. The circuit has over overload and terminal protection.







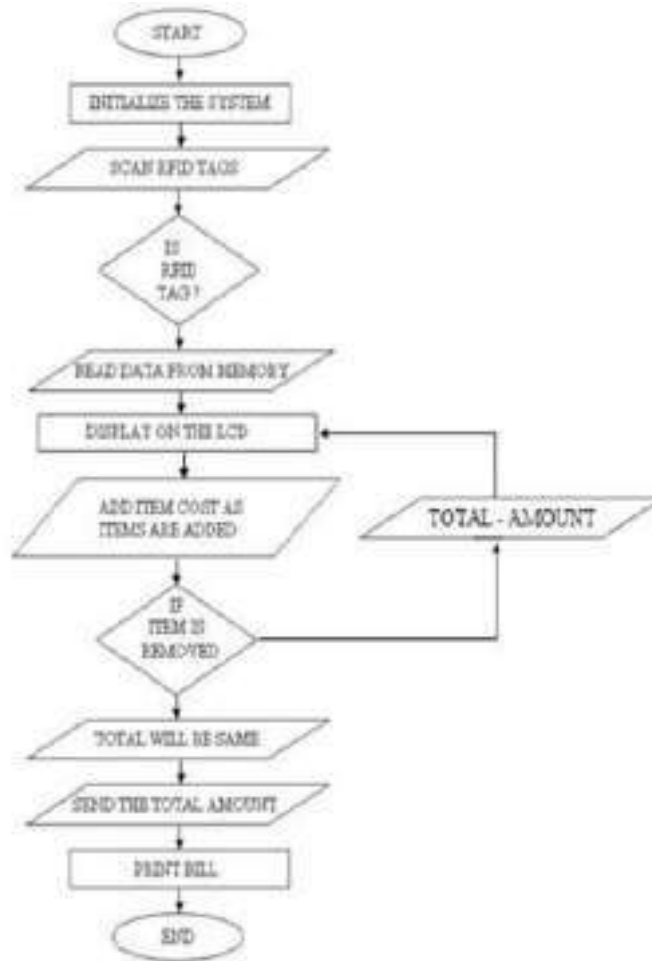
## RFID and Arduino configuration and interaction



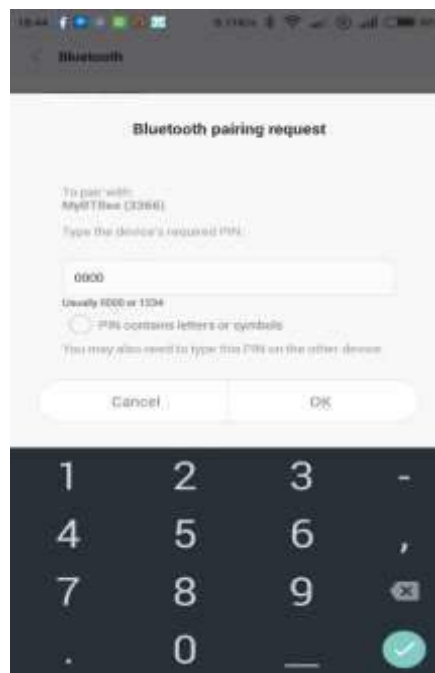
### Software configurations Arduino Bluetooth controller app



### Program flow



### Bluetooth Pairing





### Billing server page

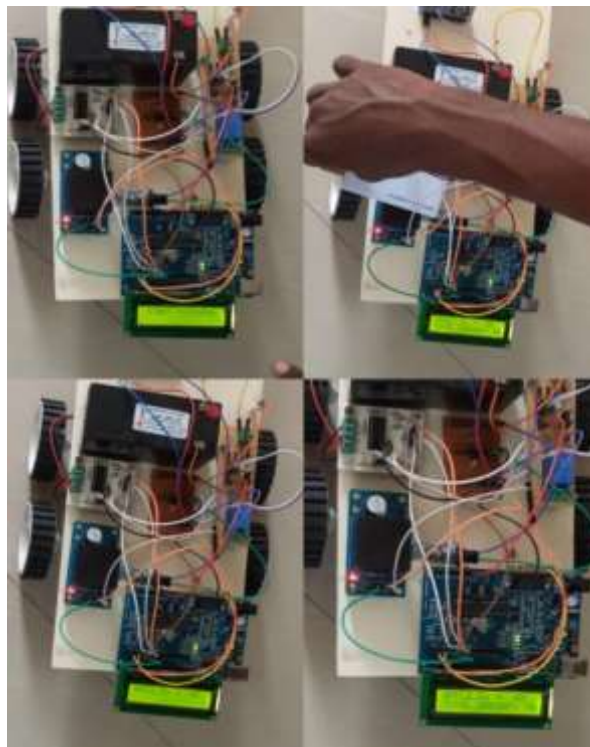
This page is built in PHP. When the shopper drops his products into the trolley the amount of the product dropped into the trolley and the total amount of trolley is displayed near the building counter through this server and it is also displayed on the LCD display of the trolley.



### Working of Trolley

After the Bluetooth pairing and Wi-Fi pairing, the audio command is passed from the android Bluetooth controller app to the Arduino. For example, if the person wants to navigate to the fruits session he can give the audio command as "fruits". The trolley moves toward the fruits session.

After the trolley navigates to expected session the person can start purchasing. When the tag on the product is placed on the RFID reader the amount of the respective product is added to the total amount of purchased products. If the person wishes to remove product from the trolley he can again scan the product on the RFID reader so that the amount of the removed product will be deducted from the total amount of purchase.





## REFERENCE

1. M. A. Lambay, A. Shinde, A. Tiwari, and V. Sharma, "Automated billing cart," *Int. J. Comput. Sci. Trends Technol.*, vol. 5, pp. 148–151, Mar./Apr. 2017.
2. S. Jadhav, S. Kamath, S. Yadav, A. Rajput, and P. K. S. Sakure, "Smart shopping application using NFC," *Int. Res. J. Eng. Technol.*, vol. 5, no. 3, pp. 1521–1524, 2018.
3. D. Choi, C. Y. Chung, and J. Young, "Sustainable online shopping logistics for customer satisfaction and repeat purchasing behavior: Evidence from China," *Sustainability*, vol. 11, no. 20, p. 5626, 2019.
4. Dr. P. MuthuKannan, Anupriya Asthana, "Automatic Retail System Using RFID", Volume 1, Issue 5, October 2013, *International Journal of Advance Research in Computer Science and Management Studies*.
5. Zeeshan Ali, Reena Sonkusare, "RFID Based Smart Shopping and Billing", *International Journal of Advanced Research in Computer and Communication Engineering* Vol. 2, Issue 12, December 2013.
6. Raju Kumar, K. Gopalakrishna, K. Ramesha, "Intelligent Shopping Cart", *International Journal of Engineering Science and Innovative Technology (IJESIT)* Volume 2, Issue 4, July 2013.
7. Satish Kamble, Sachin Meshram, Rahul Thokal, Roshan Gakre, "Developing a Multitasking Shopping Trolley Based on RFID Technology", *International Journal of Soft Computing and Engineering (IJSCE)* ISSN: 2231-2307, Volume-3, Issue-6, January 2014.
8. VarshaJalkote, Alay Patel, VijayaGawande, Manish sBharadia, Gitanjali R. Shinde, Aaradhana A Deshmukh "Futuristic Trolley for Intelligent Billing with Amalgamation of RFID and ZIGBEE", *International Journal of Computer Applications (0975 – 8887) International Conference on Recent Trends in engineering & Technology - 2013(ICRTET'2013)*.
9. J.S.Awati, S.B.Awati, "Smart Trolley in Mega Mall", *International Journal of Emerging Technology and Advanced Engineering* (ISSN 2250- 2459, Volume 2, Issue 3, March 2012)
10. Dr.K.V.K.K.Prasad, "Embedded/Real time operating systems",. Dreamtech Publications 2010 Edition. [8].Mingyan Li, , Rainer Falk paper on "multi-domain access control using asymmetric key based tag reader mutual authentication", Dreamtech Publications 2012 Edition.
11. Kamran Ahasan,Paul Kingston IEEE paper on "rfidapplications:an introductory and exploratory study" in 2018.
12. Dr. P. MuthuKannan, Anupriya Asthana, "Automatic Retail System Using RFID", Volume 1, Issue 5, October 2013, *International Journal of Advance Research in Computer Science and Management Studies*.
13. Zeeshan Ali, Reena Sonkusare, "RFID Based Smart Shopping and Billing", *International Journal of Advanced Research in Computer and Communication Engineering* Vol. 2, Issue 12, December 2013.
14. Raju Kumar, K. Gopalakrishna, K. Ramesha, "Intelligent Shopping Cart", *International Journal of Engineering Science and Innovative Technology (IJESIT)* Volume 2, Issue 4, July 2013.
15. Satish Kamble, Sachin Meshram, Rahul Thokal, Roshan Gakre, "Developing a Multitasking Shopping Trolley Based On RFID Technology", *International Journal of Soft Computing and Engineering (IJSCE)* ISSN: 2231-2307, Volume-3, Issue-6, January 2014.
16. VarshaJalkote, Alay Patel, VijayaGawande, Manish sBharadia, Gitanjali R. Shinde, Aaradhana A Deshmukh "Futuristic Trolley for Intelligent Billing with Amalgamation of RFID and ZIGBEE", *International Journal of Computer Applications (0975 – 8887) International Conference on Recent Trends in engineering & Technology - 2013(ICRTET'2013)*.
17. J.S. Awati, S.B. Awati, "Smart Trolley in Mega Mall", *International Journal of Emerging Technology and Advanced Engineering* (ISSN 2250- 2459, Volume 2, Issue 3, March 2012)
18. MingyanLi, Rainer Falk paper on "multi-domain access control using asymmetric key based tag reader mutual authentication", Dreamtech Publications 2012 Edition.
19. Kamran Ahsan, Paul Kingston IEEE paper on "rfidapplications:an introductory and exploratory study" in 2018.



# A STUDY ON CUSTOMER AWARENESS TOWARDS PRADHAN MANTRI BHARATIYA JAN AUSHADHI KENDRA'S WITH REFERENCE TO TIRUPUR DISTRICT

<sup>1</sup>Dr.R.Rajasekaran, <sup>2</sup>Dr.K.P.Balakrishnan, <sup>3</sup>Mr.Barath Chellah

<sup>1</sup>Assistant Professor, Department of Commerce, NIFT-TEA College of Knitwear Fashion  
Tirupur – 641606

<sup>2</sup>Principal, NIFT-TEA College of Knitwear Fashion, Tirupur – 641606

<sup>3</sup>3<sup>rd</sup> B.Com, NIFT-TEA College of Knitwear Fashion, Tirupur – 641606

## ABSTRACT

*This paper is designed to check Customer Awareness towards Pradhan Mantri Bharatiya Jnanaushadi Kendra's. This study is finished to understand the knowledge, perception and attitude of individuals and patients towards generic medicines provided by the govt. At low cost through Jan Aushadhi Medical Stores, which supports and helps the people below the personal income. This helps to spot the problems faced by people and also helps to make your mind up and to relinquish solutions regarding the matter that, not every-one is aware of the schemes implemented by the govt. For the welfare of the people below the personal income. The successful solution is taking measures like campaigns, educating the people to form them more alert to the Jan Aushadhi Medical Store. The study target the degree of knowledge of individuals about Jan Aushadhi Medical Store, the people's awareness of Jan Aushadhi Medical schemes, to understand the willingness of individuals to shop for generic medicines, to review the understanding and people's perception on generic medicines, to study the satisfaction level of consumers towards quality, price, availability, accessibility, acceptability, affordability of those medicines and to understand about how the govt. Initiative measures reach among the people. For the study's aim, the researcher has selected 100 respondents who are aware of the PMBJPK. Descriptive research methodology is employed to conduct the study. It includes survey and fact-finding inquiries of various kinds. It focused on the issues of the advantages availed from PMBJPK. All levels of shoppers were surveyed by using a questionnaire and also, the level of satisfaction or dissatisfaction from PMBJPK was studied. Finally, the detailed information about the advantages they had received was also considered... Finally, it attempts to supply suggestions to the purchasers to teach way more about PMBJPK.*

**KEYWORDS:** Pradhan Mantri Bhartiya Jan Aushadhi Pariyojana Kendra (PMBJPK), Central Drug Standards Control Organisation (CDSCO), Jan Aushadhi Store (JAS), Generic Medicine, BPPI (Bureau of Pharma Public Sector Undertakings of India)

## 1.1 INTRODUCTON

JAN AUSHADHI is launched by government of India on December 2008 by the department of pharmaceuticals, ministry of chemical and fertilizers and government of India and it got registered as an independent society in April 2010.

Medicines constitute substantial proportion of out of pocket (OOP) expenses in Indian household. JAN AUSHADHI aims at providing cheap and generic medicines through JAN AUSHADHI stores establishes across the country. These stores not only provide cheaper product but also quality products at





cheaper prices. These medicines are provided through specialized centres known as PRADHAN MANTRI BHARATHIYA JAN AUSHADHI PARIYOJANA KENDRA (PMBJPK). It has been launched by Prime Minister of India, Sree Narendra Modi. These stores are mostly opened near Government hospitals to provide low cost medicines to poor and needy. Financial supports are also provided to the JAN AUDHADHI store owners (NGO's / Agencies / Individuals) upto 2.50lakhs. Increased health care expenses remain a major concern worldwide, especially in underdeveloped and developing countries where majority of the people are unable to meet them and India is no exception. According to one of the estimates, 70% of Indian people spend their 10-20% of total income as health expenses and adds up to their financial difficulties that 3.2% of Indians live below poverty line and lack of the health insurance further compounds to the above situations. At the top of the above scenario, the Indian market has number of same drug formulations with different brand names. According to one of the reports, 11 lakh brand medicines are registered and made of 1000 active pharmaceutical ingredients. This has resulted because of mushrooming of large number of pharmaceutical industries as India is ranked 3<sup>rd</sup> largest in volume and terms who brand the same medicines by different brand names.

### 1.2 SCOPE OF THE STUDY

1. The focus of this research work is to primarily study on the positive impact of Jan Aushadhi medical scheme towards people who is not affordable to buy medicine at high prices and also the people's awareness on this scheme.
2. This study is confined to urban areas and can be extended to rural areas where a vast population have to rely on generic medicines.
3. This study can be extended to rural areas of Karnataka which can provide a holistic view of attitude and acceptance of Jan Aushadhi by both rural and urban customers of Tirupur.

### 1.3 OBJECTIVES

- To know the customer awareness towards Jan Aushadhi Medical shops.
- To study the attitude of customer towards Jan Aushadhi Medical shops.
- To measure the relationship between Branded medicines and Jan Aushadhi.

- To offer suitable promotional for Jan Aushadhi stores.

### 1.4 RESEARCH METHODOLOGY

Descriptive research is followed in this research. The universe of the population includes the respondents who are the customers of Jan Aushadhi, Tirupur. The samples were selected among the customers of Jan Aushadhi located at Tirupur for this research. The samples were chosen from the population, by using Convenience sampling technique (i.e. Non-probability sampling technique), because the exact population size is unknown and the accessibility of the customer is difficult. Survey method of data collection was used in this research. The primary data were collected using structured questionnaire. The research design is descriptive and empirical. The researcher intends to use this type research in order to explain customer satisfaction level towards Jan Aushadhi product. Necessary data required for analysis are collected through questionnaire.

### 2.1 REVIEW OF LITERATURE

Rajbil (2011), in his article, he constructed a tool to measure customers' satisfaction in retail pharmacy. Customer satisfaction is considered as the important determinants of service quality. In this context, it becomes more relevant to study pharmacy service quality expectations and perceptions of customers. This study aims to measure expectations and perceptions with respect to retail pharmacy.

Jose Augusto Rosa Bastos (2008), in his research paper, developed a model to demonstrate that loyalty is a consequence of service quality and customer satisfaction. A specific scale has been developed and applied to a survey at a two level of Portuguese pharmacies: rural (with no competition) and urban pharmacies (with some competition). Using a structural equation modeling methodology we demonstrate that the more competition (urban pharmacies) less loyalty, the more dependent with the service (high consume in product pharmacies) the more loyal.

### 3. FINDINGS

1. 93% of the respondents are male and 7% of the respondents are female. The majority (93%) of the respondents are male.
2. 88% of the respondents are below 25, 8% of the respondents are 26 -35, 0% of the respondents are 36-45 and 4% of the respondents are above 45. The majority (88%) of the respondents are below 25 .



3. The above table and chart shows the marital status of respondents. 88% of the respondents are single and 12% of the respondents are married. The majority (88%) of the respondents are single.
4. 55% of the respondents are UG, 18% of the respondents are school level, 15% of the respondents are PG and 12% of the respondents are others. The majority (55%) of the respondents are UG.
5. 60% of the respondents are joint family and 40% of the respondents are nuclear. The majority (60%) of the respondents are joint family.
6. 42% of the respondents are rural, 48% of the respondents are urban and 10% of the respondents are semi-urban. The majority (48%) of the respondents are urban.
7. 7.42% of the respondents are below 10,000, 35% of the respondents are 10,001 – 15,000, 5% of the respondents are 15,001– 20,000 and 18% of the respondents are above 20,000. The majority (42%) of the respondents are below 10,000.
8. 52% of the respondents are aware about the Jan aushadhi medicals and 48% of the respondents are not aware. The majority (52%) of the respondents are aware about the Jan aushadhi medicals
9. 32% of the respondents are visited to Jan aushadhi medicals and 68% of the respondents are not visited
10. 75% of the respondents are much better and 25% of the respondents are much worse. The majority (75%) of the respondents are much better.
11. 80% of the respondents are satisfied, and 20% of the respondents are not Satisfied. The majority (80%) of the respondents are satisfied
12. There is no difference between male and female of the respondents with respect to the availability of all types of medicines, price, ability of staff, availability of all company medicines, order booking facility, home delivery service, payment options, hygiene and cleanliness of the store, maintenance of medicines at proper temperature, and proper information printed in package of medicines in Jan Aushadhi store.

#### 4. CONCLUSION

Through the research paper entitled, "A study on customer satisfaction towards Jan Aushadhi", it is concluded that the demographic

variables such as age group, gender and occupation are having less impact on the factors of customers satisfaction. The research outcome also indicates that, most of the customers were satisfied towards Jan Aushadhi medial store with respect to the chosen factors. In a competitive world, firms expect to increase the quality and customer satisfaction, and obtain customers more loyalty to the firm. These are keys to lead the market. The understanding of what drives the customer to be more loyal is the crucial element of all. Our objective for this study is to clarify relationships between service quality, customer satisfaction, and loyalty (as a positive behavioral intention). The customer decision-making process for service products, and especially with services that are linked to health, is modeled as a complex system that incorporates direct and/or indirect effects on behavioral intentions. The presented results, supports this position. Moreover, this is a quasi-beginning study in a service that is not explored in the analysis of quality, satisfaction, and customer loyalty. So, this appears to be a worthy area to pursuit. We provide evidence that quality direct affect satisfaction and satisfaction direct affect the positive behavioral intentions. The direct effect of service quality in behavioral intentions was not confirmed. Using a structural equation modeling methodology we demonstrate that the more competition (urban pharmacies) less loyal, the more dependent with the service (high consume in product pharmacies) the more loyal. An interesting result is that there are no negative behavioral intentions in the pharmacies customers. This is due, certainly, to the impossibility to the customer to change from one pharmacy to another and to the dependency of must customers to the pharmacy services. There are many implications from this study to future researches. The replication of this study is one of them. But, more and different variables should be considered in new models. The variables introduced in the exploratory factorial analysis and not confirmed in the structural equations analysis could be more important when the market structure of the pharmacies will be competitive. This study also indicates that the customers loyalty towards the Jan Aushadhi is also good.

#### REFERENCES

1. Anderson, E.W. (1996): "Customer satisfaction and price tolerance.", *Marketing Letters*, Vol.7, pp. 19-30.
2. Anderson, E.W. and Sullivan, M. (1993): "The antecedents and consequences of customer satisfaction for firms.", *Marketing Science*, Vol. 12, pp. 125-143.



3. Athanassopoulos, A.D. (1998): "Another look into agenda of customer satisfaction: focusing on service providers own and perceived viewpoints.", *International Journal of Banking Marketing*, Vol. 15.
4. Athanassopoulos, A.D. (1999): "Customer satisfaction cues support market segmentation and explain switching behaviour.", *Journal of Business Research*, Vol. 47, pp. 191-207.
5. Babakus, E. and Mangold, G.W. (1992): "Adapting the SERVQUAL scale to hospital services: an empirical investigation", *Health Services Research*, Vol. 26, pp. 767-86.
6. Ballester, E. D. and Aléman, L.M. (2000): "Brand trust in the context of consumer loyalty.", *European Journal of Marketing*, Vol. 35, pp. 1238-1258.
7. Barbara, R.L. and Soureli, M. (2006): "The Antecedents of consumer loyalty in retail banking.", *Journal of Consumer Behaviour*, Vol. 5, pp.15-31.
8. Berry, L.L., Zeithaml, V.A., and Parasuraman, A. (1985): "Quality counts in service too.", *Business Horizont*, Vol. 38, pp. 44-52.
9. Biong, H. (1993): "Satisfaction and loyalty to suppliers within the grocery trade.", *European Journal of Marketing*, Vol. 57, pp. 21-38.



# A STUDY ON DIVIDEND POLICY OF TAMILNADU NEWSPRINT AND PAPERS LIMITED WITH SPECIAL REFERENCE TO 2014-15 TO 2019-20

**Dr.C.RAJA**

*Associate Professor, Department of Commerce, NIFT – TEA College of Knitwear Fashion Tirupur*

---

## ABSTRACT

*The present study aims to identify the financial strengths and weaknesses of the Tamil Nadu Newsprint and Papers Limited (TNPL) by properly establishing relationships between the items of the balance sheet and profit and loss account. The study has been undertaken for the period of Six years 2014 -15 to 2019-20 and the necessary data have been obtained from CMIE database. The liquidity position was strong in case of TNPL thereby reflecting the ability of the company to pay short-term obligations on due dates and they relied more on external funds in terms of long-term borrowings thereby providing a lower degree of protection to the creditors. Financial stability of TNPL has showed a downward trend and consequently the financial stability of TNPL has been decreasing at an intense rate.*

*This is a major limitation of the research. The study is of crucial importance to measure the firm's liquidity, solvency, profitability, stability and other indicators that the business is conducted in a rational and normal way; ensuring enough returns to the shareholders to maintain at least its market value. The study will help investors to identify the nature of paper industry and will also help to take decision regarding investment.*

**KEYWORDS**—TNPL, Newsprint, Dividend, Papers

---

## I.INTRODUCTION

Finance always being disregarded in financial decision making since it involves investment and financing in short-term period. Further, also act as a restrain in financial performance, since it does not contribute to return on equity. A well designed and implemented financial management is expected to contribute positively to the creation of a firm's value. Dilemma in financial management is to achieve desired tradeoff between liquidity, solvency and profitability.

Management of working capital in terms of liquidity and profitability management is an essential for sound financial recital as it has a direct impact on profitability of the company. The crucial part in managing working capital is required maintaining its liquidity in day-to-day operation to ensure its smooth running and meets its obligation. Ultimate goal of profitability can be achieved by efficient use of resources. It is concerned with maximization of shareholders or owners wealth. It can be attained

through financial performance analysis. Financial performance means firm's overall financial health over a given period of time. Financial performance analysis is the process of determining the operating and financial characteristics of a firm from accounting and financial statements. The goal of such analysis is to determine the efficiency and performance of firm's management, as reflected in the financial records and reports. The analyst attempts to measure the firm's liquidity, profitability and other indicators that the business is conducted in a rational and normal way; ensuring enough returns to the shareholders to maintain at least its market value. The Indian Paper Industry is a booming industry and is expected to grow in the years to come. The usage of paper cannot be ignored and this awareness is bound to bring about changes in the paper industry for the better. Paper Industry in India is moving up with a strong demand push and is in expansion mode to meet the projected demand of 20 Million tons by 2022. In order to keep the Indian Paper industry rolling, the foremost thing



which must be kept in mind is the availability of the raw materials. Every possible effort is to be made to take India at par with the other paper industries of the world. Application of paper is varied and one cannot think of a life without paper. The raw materials need to be of good quality. There should be enough modernized techniques to carry out production. Reducing costs should be accompanied by low cost of production. Policies should be implemented to bring about optimum production. Government has completely de-licensed the paper industry with effect from 17th July, 1997. The Paper industry is a priority sector for foreign collaboration and foreign equity participation upto 100% receives automatic approval by Reserve Bank of India. There are, at present, about 515 units engaged in the manufacture of paper and paperboards and newsprint in India. Obviously TNPL is a public sector company and it has been the backbone of the Indian economy, as it has acted as a strategic partner in the nation's economic growth and development.

### 1.1. Introduction about TNPL

The Tamil Nadu Newsprint and Papers Limited (TNPL) was established by the Government of Tamil Nadu to produce newsprint and writing paper using biogases, a sugarcane residue. The Government of Tamil Nadu listed the paper mill in April 1979 as one of the most environmentally compliant paper mills in the world under the provisions of the Companies Act of 1956. The factory is situated at Kagithapuram in the Karur District of Tamil Nadu and Manapparai, Trichy district of Tamilnadu. The registered office of the company is located in Guindy, Chennai.

### 1.2 Introduction about Dividend

A dividend is the distribution of some of a company's earnings to a class of its shareholders, as determined by the company's board of directors. Common shareholders of dividend-paying companies are typically eligible as long as they own the stock before the ex-dividend date. Dividends may be paid out as cash or in the form of additional stock.

- A dividend is the distribution of some of a company's earnings to a class of its shareholders, as determined by the company's board of directors.

- Dividends are payments made by publicly-listed companies as a reward to investors for putting their money into the venture.
- Announcements of dividend payouts are generally accompanied by a proportional increase or decrease in a company's stock price.

## II. REVIEW OF LITERATURE

**Campbell (2008)** constructed a multivariate prediction model that estimates the probability of bankruptcy reorganization for closely held firms. Six variables were used in developing the hypotheses and five were significant in distinguishing closely held firms that reorganize from those that liquidate. The five factors were firm size, asset profitability, the number of secured creditors, the presence of free assets, and the number of under-secured secured creditors. The prediction model correctly classified 78.5% of the sampled firms. This model is used as a decision aid when forming an expert opinion regarding a debtor's likelihood of rehabilitation. No study has incorporated the financial performance analysis of the central public sector enterprises in Indian drug & pharmaceutical Industry. Nor has any previous research examined the solvency position, liquidity position, profitability analysis, operating efficiency and the prediction of financial health and viability of public sector drug & pharmaceutical enterprises in India. **Satyanarayana Chary and Sampath Kumar (2011)** discussed in their article that working capital is one of the vital decisions of financial management function. Profitability and working capital relationship is frequently emphasized for deciding on the level of investment in working capital. All manufacturing firms need to understand the association between these two variables to arrive at optimal financial decisions. Though theories exist on the topic, empirical methods are inadequately focused in arriving at conclusions.

## III. METHODOLOGY

The present study covers TNPL. The necessary data have been obtained from CMIE database. The study has been undertaken for the period of Seven years from 2004-05 to 2013-14. In order to analyze financial performance in terms of liquidity, solvency, profitability and financial efficiency, various accounting ratios have been used. Various statistical measures have been used





#### IV. DATA ANALYSIS

The Financial Results for the year under review are summarized below

Particulars	(` in Crore)	
	2019-20	2018-19
Revenue from operations	3471.11	4082.71
Other Income	37.52	39.24
<b>Operating Profit (PBIDT/EBIDTA)</b>	<b>644.36</b>	615.24
Finance cost	222.59	233.36
<b>Gross Profit (PBDT)</b>	<b>421.77</b>	381.88
Depreciation & Amortization Expense	231.24	226.68
<b>Profit/Loss before tax (PBT)</b>	<b>190.53</b>	155.20
Tax Expense	60.50	60.81
<b>Profit/Loss after tax (PAT)</b>	<b>130.03</b>	94.39
Other Comprehensive Income	(2.92)	(4.12)
<b>Total Comprehensive income (Net of Taxes)</b>	<b>127.11</b>	90.27

( Source : Secondary Data)

#### Key Financial Ratios

The Management had reviewed the changes in key

financial ratios and have noted significant changes in all the ratios as given below:

Particulars	UOM	2019-20	2018-19	% change Inc / Dec	Remarks
Revenue from Operation	Rs Cr	3437.60	4040.87	-15	
EBIDTA Margin *	%	18.8	17.0	10	
Operating Profit Margin (EBIT) *	%	25.5	22.6	13	
Net Profit Margin (PAT)	%	3.8	2.3	62	Note 1
Interest cover ratio (All Loans) *	times	2.90	2.95	-2	
Debt Equity Ratio (Long term)	times	0.87	1.01	14	
Debt Equity Ratio - LTL (Excl. Project loan) **	"	0.94	1.01	7	
Current ratio #	times	1.27	1.00	27	Note 2
Debtors Turnover (as a % on Revenue)	%	15	11	-40	Note 3
Inventory Turnover (as a % on Revenue)	%	25	21	-16	Note 4
Return on Net Worth	%	7.6	5.7	33	Note 1

\*Profit prior to exceptional item

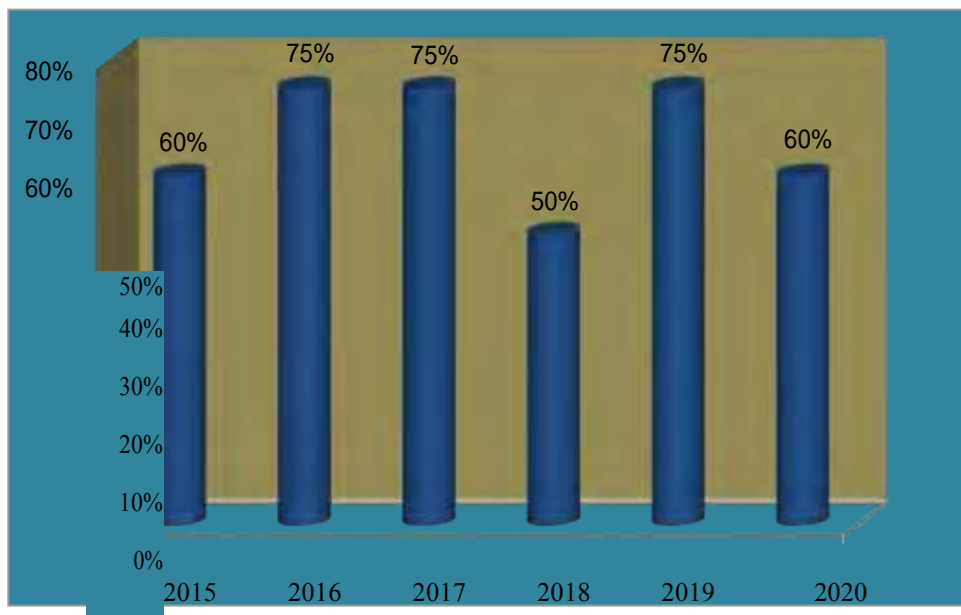
\*\* Debt includes "Current Maturities of Long Term Loans" grouped under Current liabilities

# For Current ratio, Current liability excludes "Current Maturities of Long Term Loans"



#### 4.1 Dividend Details

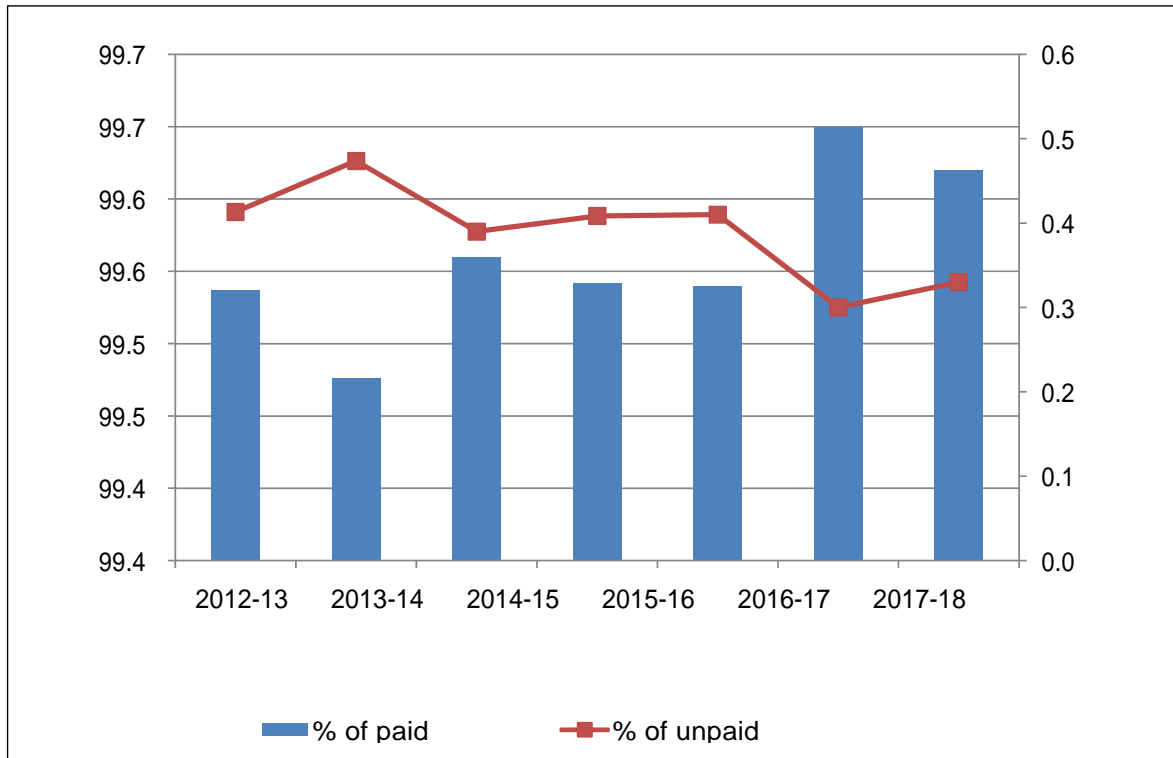
Financial Year	Dividend %	Total Dividend (Rs. in Lakhs)
2014-15	60%	4152.64
2015-16	75%	5190.80
2016-17	75%	5190.80
2017-18	50%	3460.53
2018-19	75%	5190.80
2019-20	60%	4152.63



#### DIVIDEND STATUS FOR THE LAST 7 YEARS

(` In lakhs)

SL No.	YEAR	SHARE CAPITAL	DIVI DEND %	DIVIDEND AMOUNT	DIVIDEND PAiD	DIVIDEND UNPAID AS ON 31.3.2019	% OF PAID DIVIDEND	% OF UNPAID DIVIDEND
1	2012-13	6921.06	50	3460.53	3446.40	14.13	99.59	0.41
2	2013-14	6921.06	60	4152.63	4133.13	19.50	99.53	0.47
3	2014-15	6921.06	60	4152.63	4136.36	16.27	99.61	0.39
4	2015-16	6921.06	75	5190.80	5169.59	21.04	99.59	0.41
5	2016-17	6921.06	75	5190.80	5169.29	21.51	99.59	0.41
6	2017-18	6921.06	50	3460.53	3450.18	10.35	99.70	0.30
7	2018-19	6921.06	75	5190.80	5173.47	17.33	99.67	0.33

Distribution of Shareholding as on 31<sup>st</sup> March, 2020

DISTRIBUTION SCHEDULE AS ON 31.3.2020						
Share or Debenture holding (Rs.)		No. of holders	% of Total holders	Total Shares	Total Amount (Rs.)	% of Total Amount
10	5000	31645	90.5022	3336184	33361840	4.8203
5001	10000	1627	4.6530	1274324	12743240	1.8412
10001	20000	819	2.3422	1231597	12315970	1.7794
20001	30000	280	0.8007	707540	7075400	1.0223
30001	40000	116	0.3317	419113	4191130	0.6055
40001	50000	90	0.2573	420825	4208250	0.6080
50001	100000	188	0.5376	1374015	13740150	1.9852
100001	And Above	201	0.5748	60447002	604470020	87.3377
<b>Total</b>		<b>34966</b>	<b>100.0000</b>	<b>69210600</b>	<b>692106000</b>	<b>100.0000</b>



## RESULTS

### 1. DIVIDEND

In accordance with The Companies (Declaration and Payment of Dividend) Rules, 2014, your directors recommend a dividend of 60% (i.e. Rs. 6/- per share) for the year ended 31st March, 2020. The dividend, if approved by the shareholders at the Annual General Meeting, will be paid to the equity shareholders whose names appear in the Register of Members as on 18th September, 2020. The cash outgo on the proposed dividend will be Rs. 41.53 Crs.

### 2. TRANSFER TO RESERVES

The Company has transferred Rs. 75 crore to General Reserves out of the amount available for appropriation. Rs. 88.24 crore is proposed to be retained in the profit and loss account.

### 3. PERFORMANCE HIGHLIGHTS OF THE YEAR

#### Operations

1. The Company's turnover during the year 2019-20 is Rs. 3437.60 crore.
2. Profit before tax is Rs. 190.53 crore and Profit after tax Rs. 130.03 crore.

#### Printing and Writing Paper

3. During the year the Paper production was 3,92,250 MT.
4. Achieved Paper sales of 3,78,022 MT during the Fy 2019-20. Domestic Sales accounts for 81% and Exports at 19%.

#### Packaging Paper Board

5. The packaging paper board plant production was 1,72,776 MT during the financial year 2019-20, equivalent to 86% of capacity.
6. The packaging paper board sales during the year 2019-20 was 1,71,785 MT. Domestic Sales accounts for 97%.
7. 3,30,358 tonnes of Hardwood, chemical Bagasse Pulp and Deinked Pulp were produced during the year.
8. 7658 lakh units of power was generated of which 7242 lakh units of power was consumed and 553 lakh units exported to the State Power Grid. Power drawn from State Grid and consumed only 2.14% of total power consumed.
9. The bio-methanation plants have generated methane gas of 62.13 lakh m<sup>3</sup> during 2019-20. The methane gas was consumed in lime kiln and power boilers in replacement of furnace oil 3593.3 KL and imported coal 262 MT

10. The wind farms with an installed capacity of 35.5 MW capacity have generated 404.91 lakh Kwh units of 'Green Power' during the year.
11. The paper & pulp mill have implemented various water conservation projects and reduced the overall consumption of water to 35 KL/per ton of paper which is one of the lowest in paper industry.
12. TNPL is the First and only company in the Indian Paper Industry to have established a cement manufacturing factory to convert the mill wastes lime sludge and flyash into high grade cement as part of its solid waste management system. During the year, the Company has manufactured 2,52,303 MT of cement.
13. During the year 2019-20, overall borrowings increased by Rs. 218 crore.
14. Market Capitalization was Rs. 615.63 crore as on 31.03.2020.

## V. CONCLUSION

The overall results are satisfactory as the company had to contend with severe raw materials shortages, steep escalation in costs and reduced production level due to COVID 19 pandemic. The slowdown and softening of demand during the current year resulted in reduction in sales volume. However your Company in comparison with past years achieved better sales realisations as well as production levels and improved efficiency across all areas of operation.

Due to softening of demand for Printing & Writing Paper for major part of the year ended March 2020 and despite increase in input costs in procurement of bagasse and other raw materials, the Company has earned a PBT of Rs. 190.53 Crores. This performance in adverse environment is a commendable achievement by the Management.

## VI. REFERENCES

1. Albright S.C., Winston W.L., Zappe C., 2006. *Data Analysis and Decision Making, 3th edition, Thompson South-Western: Mason, USA.*
2. Campbell, J., J. Hilscher and J. Szilagyi, 2008. *In search of distress risk. J. Finan., 63(6): 2899-2939.*
3. Satyanarayana Chary and Sampath Kumar, (2011). *Relationship Between Working Capital And Profitability - A Statistical Approach, International Journal of Research in Finance & Marketing, 1(7), 1-16.*
4. Camelia Burja, (2011). *Factors Influencing the Companies' Profitability, Annales Universitatis Apulensis Series Oeconomica, 13(2), 215-224.*



# BLOOD BANK SYSTEM BASED ON DYNAMIC LOCATION UPDATION

<sup>1</sup>Ankit Kumar Saini, <sup>2</sup>Avneesh Yadav, <sup>3</sup>Harshit Garg, <sup>4</sup>Utsav Chhaparia

<sup>1</sup>Assistant Professor,

<sup>1,2,3,4</sup>Department of Computer Science and Engineering,

Meerut Institute of Engineering and Technology, Meerut, U.P. India

---

## ABSTRACT

*This Paper discuss about the benefits of Blood Donation and its Management which is a major concern for all the health workers and blood recipients and thus this project helps in improving communication between the blood donors and people in need of blood ultimately providing an extra hand to all the health care workers and removing communication gap. The blood management system offers functionalities to quickly access the donor and blood recipients records collected from various parts of the country and to monitor the performance and blood donation activities such as a minimum three months gap to be maintained after the donation of blood and also if there is change in location of any of the user i.e. the donor or receiver shifts to new place then the location of the new place will be updated in the database automatically. It is a Web-based Application through which Registered Hospitals and Recipients can check the availability of required Blood and can send Requests for blood to the nearest blood bank or the donor with the same blood type and can be ordered online as and when required. In this, Blood Banks can also send the request to donors and other banks for blood. It is also having a communication system for donor and receiver.*

**KEYWORDS:** *Dynamic Location Updation, Blood Management, Geo plug-in API, IP Address*

---

## 1. INTRODUCTION

With the increase in population at such rapid speed, there is also an increase of many new diseases and evolution of the old one. With the new and old diseases, there are several other factors which cause loss of life. In the case of a patient being severe or not so severe, in both cases, there might be a need for blood that matches the blood of the patient. Unfortunately, there have been cases in which a man lost his life due to not getting blood in time. An increase in population has indeed increased the number of blood-donors but their percentage hardly reaches 10% of the total population and the one in need of that blood stays at large. The medical advancement has increased the demand for blood for the patients and also for several other testing. Due to lack of proper communication between the two bodies namely the donors and the institution needing blood and mismanagement of the data of the blood causes many losses of life. These problems can be overcome by the proper introduction of an automated and synchronized database which is accessible to the donors and the receivers. A system needs to be developed that works on the high end, efficient, and highly available and easily accessible by the user. The management of its database needs to be up to date and hence we are having dynamic location updation method where if a user changes its geographical location to any part of the world then he will be send a notification stating that would he like to change its location on the database and if user clicks any of the option then the database will be updated accordingly. The updation in location from the database is utmost important for maintaining the legitimacy of the whole service and also the purpose of the web service is to help people save lives by receiving blood needed and also for the institutes like blood banks and hospitals providing blood to the patients to keep a record of the available blood and its type. This web service is based on the technology of cloud computing and database management systems. This





will not only save lives but also bridge the gap between the one in need of blood and the one providing it to the needed because of the clarity to the patient and his or her people as in where to go and approach for proper blood type in less amount of time. This will reduce the efforts on both sides. The main objective other than creating ease for the patient is to create an easy way for the hospitals and the blood banks to enter the details about blood groups, and its quantity available for the use and also the details of the patient and donors and keeping a track of this database. The existing system has many flaws to it namely it is time-consuming, not has dynamic updation of data facility, it leads to error-prone results, consumes a lot of human effort to keep a proper track and people working in the medical field do not have much time and effort to spare. Other faults residing in the current system is the lack of security of data and once lost it is not easily restored and takes a lot of time, accuracy and success rate of this system is unexpectedly very low. The final reports about the transaction also take a lot of time. These faults seem not to be much but can cost lives sometimes as the one treating the needed and the one in need might be taking the most precious thing of all "time". The system proposed not only makes access to data easy but also saves a lot of time and effort which in the medical field is of most priority. It would spare nurses and would provide more manpower to a medical expert who otherwise was busy working filling in details about the blood transaction on a not so efficient system.

## 2. METHODOLOGY

### 2.1 PROPOSED SYSTEM

The proposed system (Blood Bank System based on Dynamic Location Updation) is designed to help the Blood Bank administrator to meet the demand of Blood by requesting information and notifying the receiver, the registered institution providing and safekeeping the blood and the donor about the availability of blood accordingly. This system gives the organized strategy of how to fill the gap between Donor, Recipient and Blood Banks.

When User interacts with the application, He/she will have either the option to login as an admin or as a donor or acceptor. Then he will select as an option either to go as a donor or acceptor.

As a blood receptor he has to provide information like name, mobile, aadhar no, email, blood group required. As a donor, he is required to provide information like name, mobile, aadhar no, email, gender, blood group and address.

As ADMIN his information is already stored in the database & he is required to provide the correct username and password. Only then he will be able to modify any changes in the application like he can manage blood units stock, he can also edit, delete and take care of the donor's and recipient's list and can also monitor the previous users who have either donated the blood or have received the blood.

This system substantiates minimum paperwork and also assists blood recipients, banks and donors. Using our application, the user can directly check from our application about the blood availability and hence reduces the effort of going to the blood bank.

This Application will provide a common ground for the both (i.e., Recipient, Donor) and will ensure easy and fast fulfillment of the demand for Blood requested by Recipient.

It also ensures that there should be at least 3 months gap period between the donors who are willing to donate the blood, based on the previous date they have donated the blood so there are no health complications for the donor.

The unique feature which we have implemented in this is dynamic location updation which ensures legitimacy of the database and will help the system and recipient to provide the list of the donors at new location automatically.

The proposed system consists of the subsequent goals and has the scope as follows:

- a. Goals:
  - To ease the process of blood transmission.
  - To cultivate the commenced system.
  - To upgrade into a scalable system.

In this project, there are 2 models.

1. Donors
2. Acceptors

**Donors/Acceptors** They are required to fill their respective credentials and should respond to the call when needed.



One more task provided to Donors/Acceptors is that during the instance they shift to new place then they have to respond to the notification of giving the location access from the device to the service so the new location can easily be fetched and updated in the database automatically.

#### Module 1: Web Application

This module consists of all the processes of how the blood transmission process takes place. This web application consists of several web pages for a donor/recipient to get himself registered/updated and also to request/donate the blood as and when required and there are some additional features with the administrator of the web application such as to approve the blood request and also will be able to fetch the past completed records and will be able to manage/update the stock information as received from the institutions.

### 2.2 System Analysis

Our Blood Bank System extensively uses one of the most widely used technologies PHP. Whenever the client clicks on any of the buttons, a Session Request is created which, using the web container, passes to the application console. The console consists of many PHP Pages which are run using the XAMPP server. That PHP code checks for the changes in the Database (if any) and matches it from the latest modified database.

When a user visits the application, it has to select himself as a donor or a receptor. In either condition, he has to fill his credentials. That data is stored in the database tables (donor table and receptor table) which are also referenced to the PHP Pages like donate.php, signin.php, search.php, donor.php, etc....

When the user visits our application, if his data is stored previously on the portal then user is navigated to the usernav.php where he/she can make modifications in his information. If his identity is not stored on the portal then he will be redirected to the navigation.php where his/her profile option will be hidden and only limited access will be granted.

Coming to the Administrator Console, whenever a user tries to log in as an Admin, he has to fill in his assigned username and authorized password. His credentials are verified from the admin table from the database and if matches, only then the user is granted permission to manipulate the system otherwise an error message is displayed indicating that the entered username and password do not match with the one already stored in the system.

Now Admin can also make new entries to the admin table in the database to add new people as system administrators. He/she can also manage the Blood Stock by incrementing or decrementing the amount of blood quantity available currently.

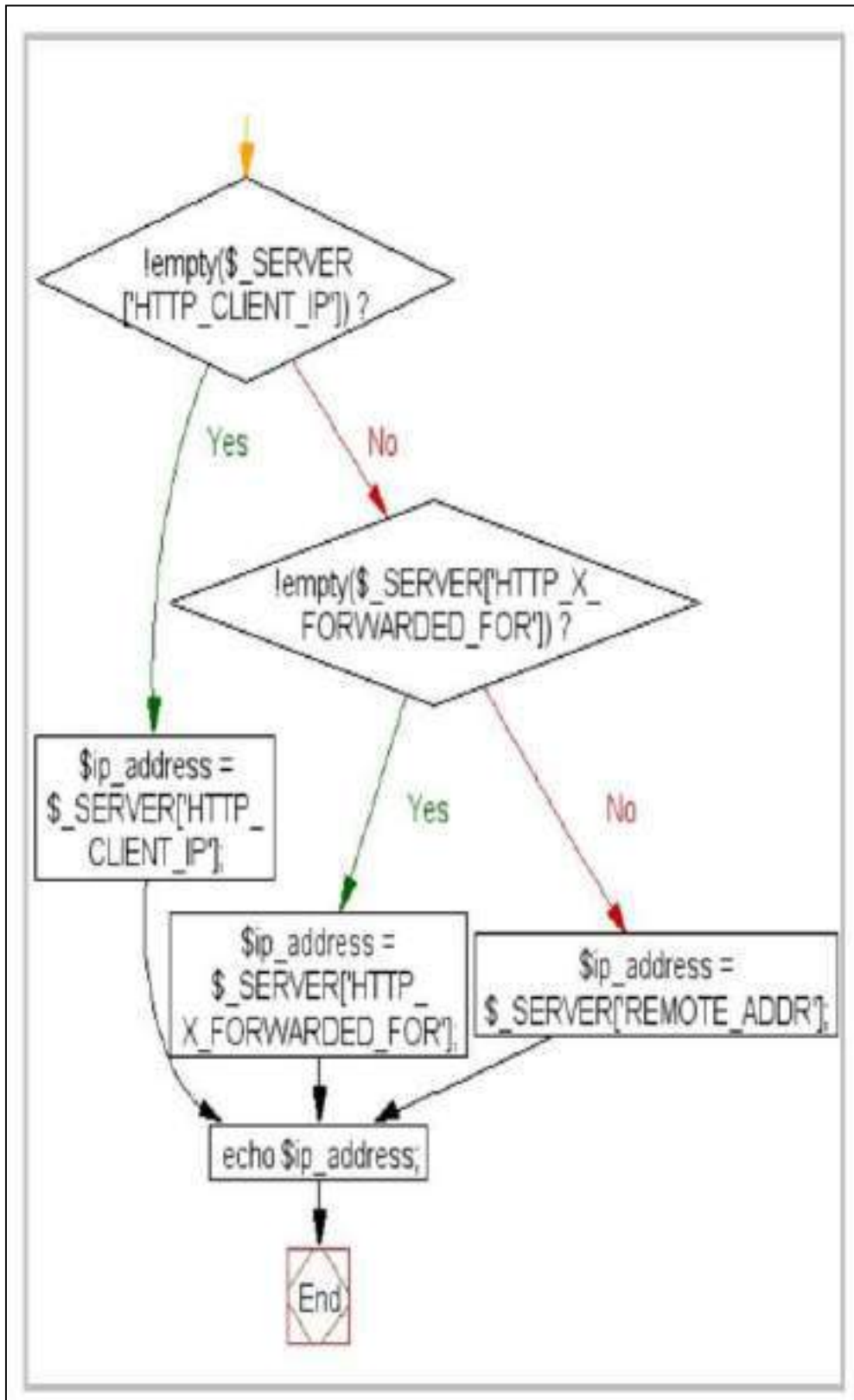
He can also add a new Donor or Receptor by clicking on the add New Donor/Receptor Button and can enter the details of the donor/Receptor manually if he wants. That data will get stored in the donor/acceptor table. He can also bring changes to data entered from the user interface only and not consult the database.

One of the most important functions that an admin performs is that he keeps a track record of the donors and receptors that get their job done. The admin prohibits those donors in the request completed section and when any old donor tries to make a data entry again then a check from the previously stored data is performed and allowed only and only if there is a 90 days gap between the blood donations. Thus, the system in a way also maintains the health record of the donors.

Furthermore, the location of the donors will be tracked dynamically and will get updated in the database. This will take place using the Geo-Plug-in Restful APIs that will fetch the IP Address of the client and using that the City and Location will get updated and changed accordingly. Now according to the new updated Location, user will have clients accordingly.



### 3. Fetching client's IP Address dynamically





### 3.1 Proposed Algorithm

The following algorithm codes are proposed for different purposes:

#### Algorithm 1: IP address Algorithm

##### Result

Variable ip\_address = IP address of the client

```
//whether IP is from share internet
```

```
If (server ['HTTP_CLIENT_IP'] is not empty)
```

```
    | ip_address = server ['HTTP_CLIENT_IP'];  
end
```

```
//whether IP is from proxy
```

```
else if (SERVER ['HTTP_X_FORWARDED_FOR'] is not empty)
```

```
    | ip_address = SERVER ['HTTP_X_FORWARDED_FOR'];  
end
```

```
//whether IP is from remote address
```

```
else
```

```
    | ip_address = SERVER ['REMOTE_ADDR'];  
end
```

```
return ip_address;
```

The IP address fetched from the above algorithm will be used to determine the latitude and longitude of the user which will be further used to determine the location of the user using Rapid API IP Geo Location which is a very trusted, verified and professionally used API.

## Algorithm 2: Location Detection Algorithm

**Result:** Database gets updated with the new Location of the User

User initial location value;

while User location does not changes

```
    | do wait;  
end
```

if Location changes then

```
    | Function Fetch_new_location ();  
        | if (old_dynamic_ip is not equal to new_dynamic_ip)  
            | update the database with new location;  
            | end  
        | end  
end
```

If it this algorithm returns new location same as the initial one then nothing will occur otherwise after it is ascertained that the user's location has been changed then the server will update the location of the user from the database.

## 4. Output Screens

The various screenshots of various activities from the application are shown below:

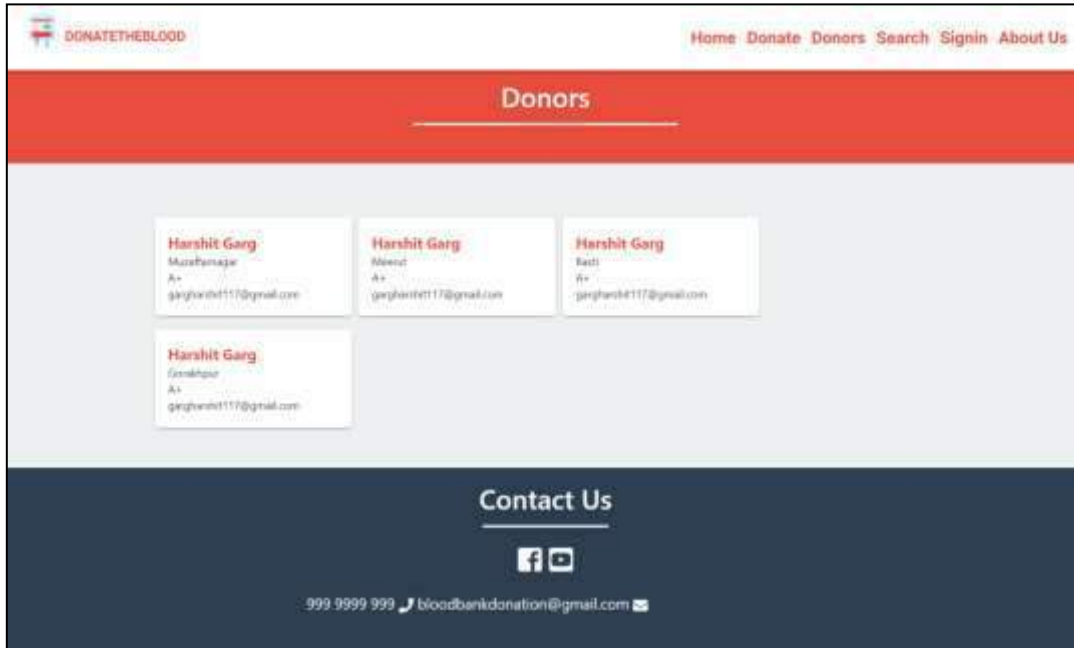


Figure 1: Home Page





This is the home page of the blood bank where if the user comes for the first time then he will be asked to signup and on the homepage if user wants to search for a particular type blood group based on a particular city he can do so.



**Figure 2: Donors list**

This is the web page showing you all the list of the donors registered on the website and will also show you the list of the donors as requested from the search option on the homepage.

name	blood_group	gender	email	city	dob	contact_no	save_life_date	password
Harshit Garg	A+	Male	gargharshit117@gmail.com	Muzaffarnagar	07-12-1980	1236547890	0	e807f11cf82d132f9bb018ca6738a19f
Harshit Garg	A+	Male	gargharshit117@gmail.com	Meerut	07-12-1980	1236547890	0	e807f11cf82d132f9bb018ca6738a19f
Harshit Garg	A+	Male	gargharshit117@gmail.com	Basti	07-12-1980	1236547890	0	e807f11cf82d132f9bb018ca6738a19f
Harshit Garg	A+	Male	gargharshit117@gmail.com	Gorakhpur	07-12-1980	1236547890	0	e807f11cf82d132f9bb018ca6738a19f

**Figure 3: Database View of Donors List**

This is the merged list of single data stored in the database formed by changing the IP addresses resulted in the dynamic updation the database i.e. location (city) got changed at every updation.

## 5. CONCLUSION

Daily new technologies are being introduced in the world and this is making our lives better by reducing the extra efforts that we have to put in and hence also reducing the time of work done. The Blood Bank Management System based on dynamic location updation proposed by us also reduces the time and effort for the acceptors and donors and constructs communication synchronization between them. This web application provides a way to contact the donors in case of emergency without having any distrust on the location of the donor. Blood recipients can put their requests for blood so that they can be contacted by the user. The database is a key component of this system as it is required to be checked continuously for the smooth working of the system.



This project has given us all an opulent opportunity to design, implement and test the application. This was helped in putting into practice various concepts of Software Engineering and Database Management Systems like maintaining the consistency, integrity and durability of the database.

Although we have put our best efforts to make this system as flexible, efficient and simple, exceptions and limitations are something inevitable. The main limitation of this application is internet connectivity and location permission given by user that cannot be ruled out. So there are some chances of getting data delivery late but once the internet connectivity is successfully established and the location permission is given, it will add on the speed.

The enhancement is always possible in every model. In future versions, its Encryption standards can be raised a level higher to make the system more secure.

Also, this system can be extended by collecting more and more data not only in cities but also in rural areas and will provide much more services for the welfare of humanity.

## 6. REFERENCES

1. "Blood-Bank\_Details", <https://www.scribd.com/document/342098928/Synopsis-ofBlood-Bank-Management-System>
2. "Research-Paper" <http://www.researchinventy.com/papers/v1i12/B0112005007.pdf>
3. "Research-Paper", <https://www.scribd.com/document/419367904/Blood-Bank-Management-System-Ijariie6874>
4. "Research-Paper", <https://www.scribd.com/document/419886668/Blood-Bank-Management-System-pdf>
5. Aware Sachin B, Arshad Rashid, Ansari aadil, Bombale R.R., "Web Based Blood Donation System".
6. Location Sensing API < <https://openweathermap.org/api> >



# Effect of Nickel and Chromium Metals on the Development of Rhizobial Colonies in *Pisum Sativum* Rhizosphere

Pandey.D<sup>\*1</sup>, Kumari.A<sup>\*2</sup>

<sup>\*1</sup>Research Scholar, G.B.Pant university of agriculture & technology, Pantnagar India.

<sup>\*2</sup>Research Scholar, G.B.Pant university of agriculture & technology, Pantnagar India

## ABSTRACT

The focus of this research is to characterize *Rhizobium* colonies isolated from root nodules of *Pisum sativum* plants and determine their tolerance to heavy metals Nickel and Chromium using CFU counts. The results showed that a bacterial colony isolated from root nodules of pea on YEMA medium is a milky white colony with a spherical convex surface. Biochemical analyses of the isolated colonies revealed that they were *Rhizobia* species, with positive results for oxidase, catalase, and bromothymol blue, but negative results for starch hydrolysis, lipase test, lysine decarboxylase, and caseinase. The presence of high levels of Nickel and Chromium resulted in a decrease in the rhizobial colony. The presence of high levels of Nickel and Chromium resulted in a decrease in the rhizobial colony. All of the colonies thrived well at pH 6 and 7, temperatures of 28° C to 30° C, and a salt concentration of 1%, according to the study.

**KEY WORDS:** *Rhizobium*, Heavy metal, CFU count, symbiotic relationship, Yeast extract mannitol agar.

## INTRODUCTION

Due to concerns about the human food chain and environmental protection, heavy metal pollution of soils and crops has become a major issue around the world. Metal pollution of soils is common as a result of human, agricultural, and industrial activities (Beladi et al. 2011). Metal remains concentrate in agricultural soils as a result of these operations, posing a risk to food safety and public health (Dary et al. 2010). Because the composition of microbial flora and microbial activity are substantially impacted by metal buildup, soil fertility is lost (Krujatz et al. 2012). These activities result in the accumulation of traces of metals in agricultural soils which pose a threat for food safety and public health (Dary et al. 2010). Some metals, though required in small amounts for organisms, can be hazardous in large amounts. One of the most serious risks to the environment and living organisms is heavy metal contamination (Wo-Niak and Basiak 2003).

In rhizobacteria, Ni is one of the micronutrients required for the production of hydrogenase, which catalyses the oxidation of hydrogen generated by nitrogenase during the reduction of dinitrogen. (Hoffman et al., 2014). Nickelin (HypB), an accessory protein that carries a dual role in Ni mobilisation into

hydrogenase and Ni storage in rhizobia, is responsible for Ni supply (Higgins, 2019).

Previous research has shown that metals have a negative impact on microorganism growth, morphology, and activity, including symbiotic nitrogen fixation (Abd-Alla et al. 2014). This symbiosis has been proposed as a way to remove or fix heavy metals from contaminated soils while also improving soil fertility (Dary et al. 2010).

As a result, finding and isolating rhizobial isolates with high levels of heavy metal resistance has been a top priority (Abd-Alla et al. 2012) In metal-contaminated soil, a symbiotic relationship promotes soil fertility while simultaneously extracting or stabilising metals, but has a negative influence on rhizobium colonies (Carrasco et al. 2005). Pollutants in the environment, such as chromium compounds, can negatively affect rhizobia, legumes, and their symbiotic relationships. Chromium toxicity to nodules includes the development of oxidative stress and protein modification (Stambulska et al. 2017). Cr treatment can cause nitrogenase deactivation and reduce nodule performance since nitrogenase is particularly sensitive to oxidation. (Stambulska et al. 2017)



Pea (*Pisum sativum* L.) is a widely farmed grain legume and fodder crop in peninsular India, and often a pulse crop. Its importance stems from its capacity to form a symbiotic connection with nitrogen-fixing rhizobacteria in the soil, which promotes plant growth and productivity. The goal of this study is to look at how Ni and Cr stress tolerance affects rhizobia's relationship with plants.

## METHODOLOGY

### SITE SELECTION AND SOIL SAMPLING PROCEDURES

Composite soil samples were collected from crop research centre, Pantnagar (Uttarakhand). At a depth of 0–20 cm, soil was removed from the plough layer. The host plant was not present in any of the soil samples when they were taken. The collected sample was air dried, then crushed with a hardwood roller on a hard wooden slab, sieved at 2mm, and kept in labelled polythene bags. Soil samples were gathered in polythene bags and delivered to 21 pots where pea seeds were planted. *Pisum sativum*, variety Azad seed were brought from Vegetable research centre, Pantnagar and sown in control, treatment and replicate pots.

Under natural settings, all experimental pots were filled with 5 kg of soil and placed in a completely randomised design with twelve replicates. The experiment had six different treatments (each with three triplicates, i.e. six treatments, 12 replicates, and three controls). The plants were taken after 9 weeks of growth. Heavy metals such potassium dichromate ( $K_2Cr_2O_7$ ) and nickel sulphate ( $NiSO_4$ ) were added at concentrations of 10ppm, 50ppm, and 100ppm solution after two weeks. Watering took place twice a week. From December to March, they were allowed to grow for four months.

### PHYSICOCHEMICAL ANALYSIS OF SOIL

The pH and EC of the soil were measured in the lab with an Orion pH/EC metre model Li -120 from Elico India Ltd., New Delhi. The Walkley and black method was used to determine the organic carbon content. The alkaline potassium permanganate test was used to estimate available nitrogen in soil.

### COLLECTION, ISOLATION, CHARACTERIZATION AND CFU COUNT OF RHIZOBIAL COLONIES.

After 55-60 days, nodules appeared in Pea. Cultivated pea plants were used to collect nodules. Treatment, duplicate, and control were chosen from the several pots. Because nodules can be found on lateral roots and the tap root, plants were uprooted with a knife to avoid severing secondary roots. The nodules

were carefully removed using a blade with lateral roots and placed in silica gel vials before being wrapped with cotton wool. (Woomer et al. 2011). The Yeast Extract Mannitol Media (YEMA) is the growth medium used to isolate rhizobia (Vincent, 1970). The following is the YEMA media composition: 10.0 g Mannitol, 0.5 g  $K_2HPO_4$ , 0.2 g  $MgSO_4 \cdot 7H_2O$ , 0.1 g NaCl, 1.0 g Yeast Extract, 15.0 g of agar and 1 litre of distilled water. Adjustment was done on the pH of the media to 6.8 using 0.1N NaOH. Dyes were incorporated in the Media: Congo Red (CR) and Bromothymol blue (BTB) that were added at a concentration of 25 ppm.

Surface sterilization of rhizobia from nodules was accomplished by immersing them in 95 percent ethanol for 5-10 seconds, then transferring them to a 2.5-3 percent (v/v) sodium hypochlorite solution and soaking them for 3- 4 minutes. Using clean forceps, the nodules were rinsed in five changes of sterile water. Following surface sterilization, the nodule was crushed in a petri-dish with a pair of blunt-tipped forceps in a huge drop of sterile water. A drop of suspension was streaked onto the agar surface to gradually dilute the suspension. The plates were then incubated in the incubator at 25-30°C. After growth, a single colony was re-streaked again on YEMA culture media for purification (Somasegaran and Hoben, 1985). The appearance, growth rate, and production of alkalinity or acidity were all used to identify typical rhizobia. To differentiate rhizobia from other bacteria, Congo red was added to the media. The viable plate account (CFU/ml) was determined after enumerating rhizobial colonies using the Most Probable Number Method (Vincent, 1970).

### GRAM STAINING OF THE BACTERIAL STRAIN

For a more specific identification of rhizobial colonies, pure cultures of bacterial colonies were subjected to gram staining. In a laminar air flow chamber, gram staining was done. The slides were first cleaned in ethanol, and colonies were then marked on them using an inoculating needle and heat fixed. The smears were therefore stained using the techniques below. a) On each slide, apply crystal violet and leave for 1 minute. c) Wash with distilled water c) Iodine as a mordant (1 minute), followed by a 95 percent alcohol wash (30 seconds), and finally distilled water. d) Safranin was added to the slides, which were then rinsed in distilled water and air dried. The entire gram staining technique was done following the Christian Gram technique and Collee JG, Miles RS Mackie (1989).



### **EFFECT OF SALT, PH AND TEMPERATURE ON RHIZOBIAL COLONIES**

The salinity tolerance of the bacteria was tested by cultivating them on YEMA medium with varied salt concentrations of 1%, 2%, 3%, and 4% (w/v) NaCl. The ability of Rhizobial isolate to grow at different pH levels was examined on YEMA medium using NaOH and HCl to alter the pH to 5.0, 6.0, 7.0, 8.0, and 9.0. Temperature tolerance was tested by growing bacterial cultures in YEMA medium at various temperatures, including 5° C, 28° C, 35° C, and 40° C.

### **BIOCHEMICAL CHARACTERIZATION OF RHIZOBIAL COLONIES**

#### **Catalase Test**

This test was conducted to see whether Rhizobium spp. had the enzyme catalase, which hydrolyzes H<sub>2</sub>O<sub>2</sub> into H<sub>2</sub>O and O<sub>2</sub> in bacterial strains. After making a smear of strain on a clean and dry glass slide, a few drops of H<sub>2</sub>O<sub>2</sub> were applied to the slide.

#### **Citrate Utilization Test**

In YEM agar medium, sodium citrate and Bromothymol blue (25 mg/l) were used instead of mannitol to examine citrate uptake as a carbon source. Rhizobium spp. isolates were streaked in YEMA medium plates with sodium citrate applied and bromothymol blue as an indicator. Following that, the plates were incubated for 24 to 48 hours.

#### **Bromothymol Blue Test**

It distinguishes between fast-growing Rhizobium isolates and slow-growing Rhizobium isolates. To examine if bacteria would react acidically or alkalinely, bacteria were inoculated on YEM agar medium with 0.025 percent bromothymol blue and incubated for 3 to 10 days. On BTB-containing YEMA medium, this test sample was allowed to develop. The positive sample turned yellow after 48 hours of incubation at 28°C due to acid production.

#### **Lipase test**

Lipase presence around bacterial colonies was detected by supplementing YEM with 1% (w/v) Tween 80.

#### **Starch Hydrolysis**

This experiment was carried out to see if Rhizobium might utilize starch as a carbon source. To assess the ability of bacteria to utilize starch, Starch Agar Medium was inoculated with Rhizobium and then iodine was added. A drop of iodine (0.1N) was dropped into a 24-hour-old culture, which revealed a definite zone of inhibition around the bacterial colonies.

### **Lysine Decarboxylase Test**

Rhizobium strains were streaked on Bromocresol Purple Falkow medium in this experiment (peptone 5 g, yeast extract 3 g, glucose 1g, Bromocresol purple 0.02 g, distilled water 1 liter). The Rhizobial strains were then streaked on the media and incubated for 24 hours at 340°C.

### **Statistical Analysis**

Statistical analysis was done in triplicates for each treatment. The mean and standard error (SE) were calculated using MS Excel, 2007

### **RESULT AND DISCUSSION**

The soil parameters were examined at the commencement of the experiment. All of the treatment plants were given heavy metal solutions. Potassium dichromate solution at concentrations of 10ppm, 50ppm, and 100ppm was applied to three treatments and their replicates. Nickel sulphate solution with concentrations of 10ppm, 50ppm, and 100ppm was applied to three treatments and their replication plants.

#### **Physico-Chemical Analysis of Soil.**

The pH is 5.70 on average, which is in the moderate acid range, and the soil is light brown in hue. It has a moderate total nitrogen concentration (0.273%) and an electric conductivity of 25.07 S cm<sup>-1</sup>. The organic carbon content of soil is 0.70 percent and the organic matter content is 1.204 percent. The heavy metal content of soil in unpolluted soils was within normal ranges.

#### **Morphological characteristics**

The isolates were round in shape with an entire edge, and their occurrence on YEMA medium was milky to watery translucent, according to morphological features. Colonies were 2.5 mm in diameter, transparent, and pale pink in colour. Rhizobium was Gram (-ve), motile, rod-shaped, and fast-growing in YEMA medium due to convex elevation.

The confirmation of isolates was done using microscopic observations, and the Rhizobium spp. was determined to be gram negative. The colonies were discovered to be gram negative, with a whitish pinkish tint and rod-shaped bacteria under the microscope.

#### **Characterization of Biochemical Processes**

Different biochemical tests were used to characterize the biochemistry of chosen isolates. Oxidase, Catalase, Citrate Utilization, Bromothymol Blue, Lysine Decarboxylase, Lipase, and Caesinase were among the test performed. The isolates in this





investigation tested positive for oxidase and catalase but negative for lipase, urease, and caseinase.

Isolates were identified as *Rhizobium* sp. based on biochemical data. The caseinase test in *Rhizobium leguminosarum* strain is negative, according to Datta et al., 2015. The oxidase test was positive in our findings, with the colonies turning dark purple to black in colour within 5 minutes in the test isolates. The catalase test was found to be positive in this investigation due to the development of bubbles around bacterial colonies. Bubble formation around bacterial colonies of all four strains was also observed by Datta et al. 2015. Javed and Asghari et al. (2008) used the same biochemical procedures to define *Rhizobium* from root nodules.

The starch hydrolysis assay, that is used to detect the generation of reducing sugar from starch in bacteria, revealed no defined zone around the isolates. Bromocresol purple falkow media was used for the lysine decarboxylase test, and there was no colour change in the *Rhizobium*-inoculated medium. Citrate was used as a carbon source in this investigation, however there was no colour change, indicating a negative citrate test. *Bradyrhizobium japonicum* and *Rhizobium leguminosarum* show no colour change and have a negative citrate test, according to Datta et al. 2015. The existence of *Rhizobium* spp. in our study is confirmed by all of the above observations and outcomes.

#### **pH, NaCl, and temperature tolerance in rhizobial colonies exposed to varied Nickel and Chromium concentrations.**

The ideal temperature for root nodulating bacteria growth ranged from 25°C to 30°C in this study. The optimal temperature for *Rhizobia* growth was determined to be 28°C, with moderate growth seen at 35°C. The optimal pH for rhizobial growth was found to be between 6 and 8 in this study. At pH 8 and pH 9, isolates grew at a very slow rate. In this study, it was discovered that *Rhizobia* grew at varied rates at different concentrations of NaCl, with the maximum growth rate occurring at 1% (w/v) NaCl and the lowest at 4% (w/v) NaCl. However, as the salt concentration was increased, the percentage of tolerant isolates declined, and only 11.1 percent of the isolates tolerated 5 percent NaCl.

#### **Effect of Nickel and Chromium on the *Pisum sativum* rhizosphere and rhizospheric bacterial colonies**

#### **Total CFU count of bacterial isolates in the presence of Nickel**

*Pisum sativum* plants in the control variant (c) were well established two months following

germination, but had a lower number of root nodules. In the soil, the CFU (colonies forming units) ml<sup>-1</sup> of free-leaving bacteria was 8 x 10<sup>6</sup> CFU ml<sup>-1</sup>, with an aspect of The Most Probable Number Method (Vincent, 1970) was used to count soil bacteria and determine the number of viable plate count (CFU/ml). Mucous production and colony shape were among the morphological features studied. During the growth of the isolates, the pH of the medium changes (Somasegaran and Hoben, 1985).

The number of bacteria in the Ni-treated variations was lower than in the control (C), with 2.77 x 10<sup>6</sup> CFU ml<sup>-1</sup> in N1 (26.3 mg Ni kg<sup>-1</sup>soil), 2.60 x 10<sup>6</sup> CFU ml<sup>-1</sup> in N2 (131.5 mg Ni kg<sup>-1</sup>soil), and 2.00 x 10<sup>6</sup> CFU ml<sup>-1</sup> in N3 (263.0 mg Ni kg<sup>-1</sup>soil). The plants in N1 were well-developed, with large nodules on the roots. The plants in N2 were likewise highly developed, having a large number of nodules on the roots, although not as many as in N1. The plants in N3 were tiny and had no obvious nodules on the roots.

#### **Total CFU count of bacterial isolates in the presence of Chromium**

Plants cultivated in C1 (56 mg Cr kg<sup>-1</sup> soil) were smaller than those produced in N1. Plants and nodules were small, but noticeable on the roots; some were lobated, and they were usually bundled in bundles. The CFU ml<sup>-1</sup> value was 3.53 x 10<sup>6</sup>, which was lower than the control variant. The plants in the C2 (280 mg Cr kg<sup>-1</sup> soil) and C3 (570 mg Cr kg<sup>-1</sup> soil) variants were tiny and lacked nodules, suggesting that the amount of Cr employed for treatment was hazardous. According to Smith (1997), the absence of nodulation was indicative of either a very low rhizobial population, below the detection limit of the plant infection assay, or a very low rhizobial population, below the detection limit of the plant infection assay or the complete absence of rhizobia from soil.

#### **CONCLUSION**

The proposed research looked at the effects of nickel and chromium on the establishment of rhizobial colonies in the root zone of *Pisum sativum*, as well as counting them using colony forming units (CFU). The study found that the heavy metals Ni and Cr impede the formation of *Rhizobial* colonies. *Rhizobium* is a gram-negative bacterium that forms a symbiotic relationship with leguminous plant roots. For biological nitrogen fixation, screening and selecting rhizobial colonies from the rhizosphere is critical. The milky white colony with round convex surface was isolated from bacterial colonies from pea root nodules that could not absorb red colour on YEMA medium. Many biochemical tests of the isolated colonies were positive, such as oxidase, catalase, and bromothymol blue, while starch



hydrolysis, lipase test, lysine decarboxylase, and caseinase were negative, indicating that the colonies recovered from pea plants are Rhizobia species. All of the colonies thrived well at pH 6 and 7, temperatures of 28°C to 30°C, and a salt concentration of 1%, according to the study.

The current study appears to be a promising approach for determining the best strategy for isolating

a rhizobial colony from a pea plant that might be employed in nitrogen fixation, but more research should be done using genetic engineering and biotechnology techniques.

**Table 1. Morphological study of Rhizobial colony**

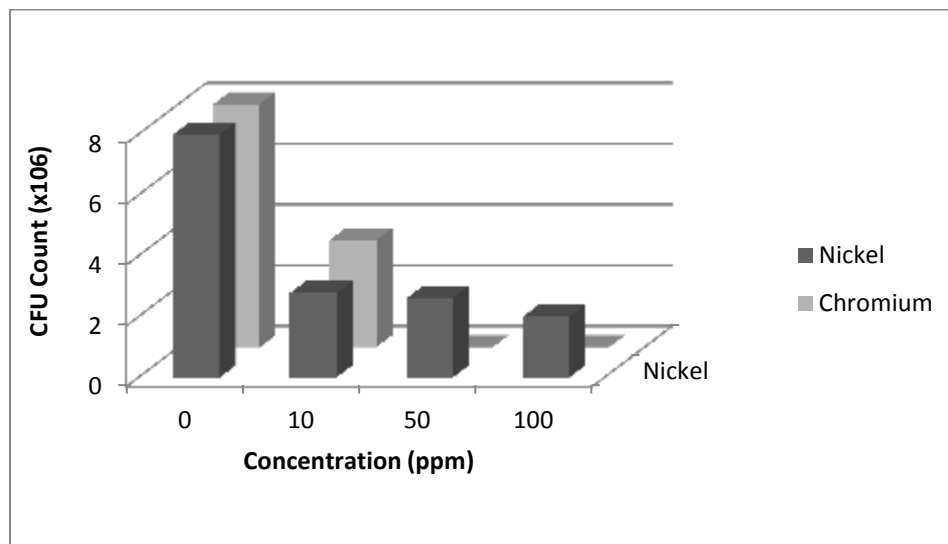
S.No	Colony characteristics	Rhizobial colonies
1.	Shape	Circular
2.	Size	2.5mm
3.	Color	White
4.	Opacity	Transparent
5.	Bacterium shape	Rod shaped
6.	Gram nature	Gram negative
7.	Motility	Mobile

**Table 2. Various biochemical tests for Rhizobial colonies**

Tests	Control	N <sub>1</sub>	N <sub>2</sub>	N <sub>3</sub>	C <sub>1</sub>	C <sub>2</sub>	C <sub>3</sub>
Bromothymol blue	+	+	+	+	+	+	+
Caesinase	-	-	-	-	-	-	-
Catalase	+	+	+	+	+	+	+
Citrate	-	-	-	-	-	-	-
Lipase	-	-	-	-	-	-	-
Lysine decarboxylase	-	-	-	-	-	-	-
Oxidase	+	+	+	+	+	+	+
Starch hydrolysis	-	-	-	-	-	-	-

**Table 3. pH, NaCl, and temperature tolerance in rhizobial colonies exposed to varied Nickel and Chromium concentrations.**

Rhizobium colonies	pH		NaCl			Temperature (°C)			
	4 pH	9 pH	0.1	0.3	0.5	10	20	30	40
C	+	-	+	+	+	-	+	+	+
N <sub>1</sub>	+	-	+	+	+	-	+	+	-
N <sub>2</sub>	+	-	+	+	+	-	+	+	-
N <sub>3</sub>	-	-	+	+	+	-	+	+	-
C <sub>1</sub>	+	-	+	+	+	-	+	+	-
C <sub>2</sub>	+	-	+	+	+	-	+	+	-
C <sub>3</sub>	-	-	+	+	+	-	+	+	-



**Figure1 .Comparison chart of rhizobial colonies in presence of Ni and Cr**



## REFERENCES

1. Ali, M. B., Vajpayee, P., Tripathi, R. D., Rai, U. N., Singh, S. N., and Singh, S. P. (2003), "Phytoremediation Of Lead, Nickel, And Copper By *Salix Acnophylla* Boiss.: Role Of Antioxidant Enzymes And Antioxidant Substances". *Bulletin Of Environmental Contamination And Toxicology*, vol 70, no. 3, pp. 462-469.
2. Dary, M., Chamber-pérez, M., Palomares, A. and Pajuelo, E. (2010), "'In Situ' Phytostabilisation Of Heavy Metal Polluted Soils Using *Lupinus Luteus* Inoculated With Metal Resistant Plant-Growth Promoting Rhizobacteria". *Journal Of Hazardous Materials*, vol 177, no. 1-3, pp. 323-330.
3. Krujatz, F., Haarstrick, A., Nörtemann, B. and Greis, T. (2011), "Assessing The Toxic Effects Of Nickel, Cadmium And EDTA On Growth Of The Plant Growth-Promoting Rhizobacterium *Pseudomonas Brassicacearum*". *Water, Air, & Soil Pollution*, vol 223, no. 3, pp. 1281-1293.
4. Higgins, K. 2019, "Nickel Metalloregulators And Chaperones". *Inorganics*, vol 7, no. 8, pp. 104.
5. Abd-alla, M. H., Morsy, F. M., El-enany, A. E. and Ohyama, T. 2012, "Isolation And Characterization Of A Heavy-Metal-Resistant Isolate Of *Rhizobium Leguminosarum* Bv. *Viciae* Potentially Applicable For Biosorption Of Cd<sup>2+</sup> And Co<sup>2+</sup>". *International Biodeterioration & Biodegradation*, vol 67, pp. 48-55.
6. Carrasco, J. A., Armario, P., Pajuelo, E., Burgos, A., Caviedes, M. A., López, R., Chamber, M. A. and Palomares, A. J. 2005, "Isolation And Characterisation Of Symbiotically Effective *Rhizobium* Resistant To Arsenic And Heavy Metals After The Toxic Spill At The Aznalcóllar Pyrite Mine". *Soil Biology And Biochemistry*, vol 37, no. 6, pp. 1131-1140.
7. Stambulska, U. Y., Bayliak, M. M. and Lushchak, V. I. 2018, "Chromium(VI) Toxicity In Legume Plants: Modulation Effects Of Rhizobial Symbiosis". *Biomed Research International*, vol 2018, pp. 1-13.
8. "Handbook For Rhizobia: Methods In Legume-Rhizobium Technology. P. Somasegaran, H. J. Hoben". Vol 70, no. 2, 1995, pp. 224-225.
9. Rosier, A., Medeiros, F. H. V. and Bais, H. P. 2018, "Defining Plant Growth Promoting Rhizobacteria Molecular And Biochemical Networks In Beneficial Plant-Microbe Interactions". *Plant And Soil*, vol 428, no. 1-2, 2018, pp. 35-55.
10. Zhang, F. and Smith, D.L. (1997), "Application of genistein to inocula and soil to overcome low spring soil temperature inhibition of soybean nodulation and nitrogen fixation," *Plant and Soil*, Vol.192, pp. 141-151
11. Wo-Niak, K., Basiak, J. (2003), "Free radicals-mediated induction of oxidized DNABases and DNA protein cross-links by nickel chloride". *Mutat. Res./Gen. Toxicol. Environ. Mutagen.* 514, 233-243
12. Hoffman, B.M., Lukoyanov, D., Yang, Z.Y., Dean, D.R., and Seefeldt, L.C. (2014), Mechanism of nitrogen fixation by nitrogenase: The next stage. *Chemical Reviews* 114(8), pp. 4041-4062.
13. Abd-Alla, M.H., Abdel-Wahab, E. El-Enany, N., Allam, David M., Khalaf, F. Mohamed.M (2014), "Synergistic interaction of *Rhizobium leguminosarum* bv. *viciae* and arbuscular mycorrhizal fungi as a plant growth promoting biofertilizers for faba bean (*Vicia faba* L.) in alkaline soil," *International Biodeterioration & Biodegradation* Vol 169, Issue 1, pp 49-58
14. Woome, P.L, Karanja, N., Kisamuli, S.M, Murwira, M, and Bala, A (2011), A revised manual for rhizobium methods and standard protocols available on the project website, [www.N2](http://www.N2)
15. Collee, J.G., Miles, R.S. (1989), Tests for isolation of bacteria, 13th ed., in: J.G. Collee, J.P. Duguid, A.G. Fraser, et al. (Eds.), Mackie and MacCartney Practical Medical Microbiology, vol. 2, Churchill Livingstone, New York, pp. 456-481
16. Javed, K & Asghari, B. (2008), Allelopathic Potential of Sunflower (*Helianthus annuus*) on Soil Metals and its Leaves Extract on Physiology of Wheat (*Triticum aestivum* L.) Seedlings. *African Journal of Biotechnology*, 7(18), pp. 3261-3265.



# AN EXAMINATION OF SOCIO-ENVIRONMENTAL PROBLEMS FACED BY AGRO-INDUSTRIES AND NEIGHBOURHOOD SETTLEMENTS IN CAMEROON: THE CASE OF CAMEROON DEVELOPMENT CORPORATION (CDC) IN FAKO DIVISION, SOUTH WEST REGION

Norah Aziamin Asongu Ph.D<sup>1</sup>, Ngoe Fritz Eseokwea Ph.D<sup>2</sup>

<sup>1</sup>Researcher/Anthropologist, Department of Economics and Environmental studies. National Centre for Education, Ministry of scientific Research and innovation, Yaounde Cameroon

<sup>2</sup>Researcher/ Economist, Department of Economics and Environmental studies. National Centre for Education, Ministry of Scientific Research and Innovations, Yaounde Cameroon

Article DOI: <https://doi.org/10.36713/epra7347>  
DOI No: 10.36713/epra7347

## ABSTRACT

*This study was carried out in Fako Division of Cameroon's South West Region with the objective of identifying the social and environmental problems created by Cameroon Development Corporation (CDC), the country's largest agro-industrial cooperation which is next employer to the government. Fako Division was selected for the study because all the major settlements in the Division have been affected by activities of CDC. Methods of data collection were qualitative using interviews, focus group discussions, and direct observation in the workers camps and third party settlements. Results of the study indicate that despite the corporation's contribution to employment; environmental and social problems attributed to the company's activities remain the greatest cause for concern affecting other human activities in the affected settlements. Deforestation and destruction of the ecosystem, untreated effluent discharged into the environment, gaseous emissions, noise pollution and aerial sprays in plantations including problems of hygiene and sanitation were identified among major problems affecting human settlements in the affected areas. Furthermore poor housing conditions, congestions, inadequate disposal of sewage and waste have been identified as greatest sources of social and health problems affecting the workers camps. The study calls for government and its agencies to conduct environmental impact and social assessment studies where the impacts could be measured to ascertain the effects on the environment and populations affected by the activities of the corporation.*

**KEY WORDS:** *Agro-industries, neighbourhood-settlements, Cameroon Development Corporation, social problems, environmental problems.*

## INTRODUCTION

The Cameroon Development Corporation (CDC) is the largest agro-industrial complex in Cameroon. Its place in the history of Cameroon is significant as it plays a major role in social, economic and even infrastructural developments in the country; especially the Anglophone regions. It is with this justification that in the early days of independence President Ahidjo the president of Federal Republic of Cameroon described CDC as "a State within a state" as the corporation has special affections of populations from all socio professional groups in Cameroon. The Cameroon Development Corporation

(CDC) as from January 1947 took over from West African Plantation Victoria (WAPV) and African Fruit Company (AFC) owned by the Germans. The CDC ordinance was tabled in Lagos the then capital of Nigeria by Mr F.E.V Smith who became the corporation's first chairman. Thereafter the corporation became property of Commonwealth Development Corporation (CDC), set up under the auspices of British post-war labour government. The name CDC was therefore born to replace the former German plantations. When French Cameroon gained independence in 1960 and West Cameroon was granted independence by joining French Cameroon





under a federation, the company was still managed by the British government. The Commonwealth development corporation continued to manage the affairs of CDC, alongside other Commonwealth businesses for fourteen years (1960-1974) and handed over to Cameroon whereby the name Cameroon Development Corporation was adopted with the same abbreviation (CDC). The Cameroon Development Corporation is now a parastatal owned by the state of Cameroon with head office in Bota-Limbe. The plantation covers a total of approximately 42,027 Hectares of land, 38,000 Hectares of mature plantations at production stage. Rubber plantations covers 22,262 Ha of land while oil palm covers 15,240 Ha and bananas 4,525 Ha. The corporation constitutes a workforce of close to 22,036 employees including temporal workers, ranking it the second highest employer after the state of Cameroon. CDC produces averagely between 18,000 and 20,000 tons of rubber, 18,000 – 19,000 tons of palm oil, 600 tons of palm kernel and an average of between 90,000 and 110, 000 tons of bananas annually (CDC, 2017)

The establishment of Cameroon Development Corporation in Fako Division has led to its occupation of vast portions of forest land used for agriculture for cultivation of mainly industrial trees. According to the Ministry of State Property and Land Tenure (2008) the corporation occupies more than half of the land mass in Fako Division. Vast areas of land meant for food production have been affected by deforestation, deprivation and dispossession of land holdings from indigenous communities drawing a similarity to the situation in Columbia, Malaysia, Brazil, Nigeria, and Congo with loss of biodiversity (Oyono, 2005). This is often done without sustainable compensation to communities including towns and villages which have been affected by activities of the industrial tree estates. Deforestation and replacement of diverse ecosystems by this large-scale monoculture continue to deprive local populations of the products and services they obtain from the forest while the use of agrochemicals increasingly affect local populations as well as their ecosystems as observed in most areas of Fako Division like Limbe, Tiko, Mondoni, Idenau Mutengene, Buea, Ekona, and Ekondo titi.in Ndian division (EMIS, 2010-2013).

The greatest predicament attributed to the presence of industrial tree estates in these settlements is environmental problems affecting land, air and water attributed to gaseous emissions and effluent discharged into the environment. In addition, the multiplier effects attributed to the impact of the ITPs; notably the CDC among other monocultures have been the reduction of food supply from peasant populations (who have been deprived of arable land), limit to expansion of human settlements as witnessed in other tropical countries which harbour monocultures. In Cameroon, legal rights to land given to Industrial Trees Plantation (ITPs) empowers

them to confiscate land and displace local communities without state intervention because all land legally belongs to the state (Oyono, 2005; EMIS 2010- 2013). Indigenous communities located around ITPs tend to have limited areas of land for agricultural activities and for expansion of human settlements thereby creating potential sources of conflict between the peripheral settlement and ITPs.

According to Baromey *et al*, (2012) large scale industrial tree plantations are expected to inject part of their revenue from extractive activities to support economic growth and development in neighbourhood settlement and the country as a whole. Meanwhile studies by Martinez (2002) in Brazil support that most agro industries fail to adequately support local communities in the extractive zones to reduce social costs incurred as a result of the activities of extractive industries. The quest for social benefits and inability of extractive industries to comply with the demands of the affected settlement have been the greatest sources of violent confrontations between the affected communities and the industrial tree plantations as witnessed in Cameroon (1947 and 2012), Malaysia (1990), Indonesia (1978) and Nigeria (2007), Thailand (1967-90) including a host of other countries in the Global South (Economic and political weekly, 2010). Unfortunately these demands have always been welcome with reprisals from state authorities without compelling extractive industries to adequately reduce social costs to the affected populations.

According to Ingram *et al*, (2014), the development of oil palm plantations has also resulted in deforestation and other negative environmental impacts, such as poor water quality in areas where effluent and other waste products from factories are directed into water used for drinking and household uses, air pollution where gaseous emission from factories affects human activities and soil degradation resulting from overuse of land resources. Reducing environmental damage and creating better conditions for the productive engagement of local communities are major challenges for plantation investment in forested frontier regions. According to studies by Asaah *et al* (2011), EMIS (2013), employment opportunities offered to indigenous people for land loss are of low quality due to low wages, which are hardly able to compensate adequately for loss of land and its sustainable resources.

### Objectives of the study

This study seeks to;

- (1) Examine the effects of CDC activities on the livelihood of communities in the study area
- 2) Identify the major environmental and social problems encountered in human settlements.



## MATERIALS AND METHODS

### Study Area

The South West region of Cameroon is located on the western fringes of the country along the coast of West Africa sharing coastal and land boundaries with Cross river state of Nigeria. The region lies between latitude 5° 12 North and longitude 9° 18 East of the Greenwich meridian (Aquah *et al.*; 2014). Based on Cameroons' 2005 census the South West Region has a population of 1,481,433, occupying a surface area of 25,410 square kilometres with a population density of 45.38 persons per square kilometre (45.38 persons/Km<sup>2</sup>). The region comprises of six Administrative Divisions namely: Fako, Meme, Ndian, Manyu, Kupe Manenguba and Lebiale.

### Vegetation and Relief

The South West Region belongs to the forest agro ecological zone of Cameroon. It is characterized by thick evergreen forest, high rainfall, high temperatures, and relative humidity. The region contains four mountains which share similarities in climate and relief to the western highlands; that is, the North West and West regions. They include Mount Cameroon (4100 m), Manenguba (2396m), Koupé (2059) and the Rumpi hill (1885m). The slope of Mount Cameroon is cultivated up to 1100 m because of its volcanic fertility which favours the growth of both export and food crops for domestic consumption (Njukwe *et al.*, 2014). These volcanic soils have attracted the cultivation of industrial trees by the Cameroon Development Corporation which has occupied vast areas of land in Fako Division to the extent that livelihood sources in the human settlements have been greatly affected in the Division.

The South West Region has two seasons; a prolonged rainy season from mid-March to mid-November, and a dry season from mid-November to mid-March. Annual average rainfall in the region is 3000mm. Dibuncha situated along the west coast records the second highest rainfall in the world with an annual average of 5000mm and maximum and minimum temperatures ranging from 38°C and 10°C respectively (Njukwe *et al.*, 2014). The relative humidity of the region is very high during the rainy season and varies from 70°C and 80°C. Its hot climate is influenced by hot currents from the Atlantic Ocean. Meanwhile temperatures at high altitude areas such as Buea, Bangem, Alou, DikomeBalue, and KoupéManenguba that share similar relief; climate and soil types with the western highlands are relatively cold. These areas of the region grow similar crops like the West and North West Regions.

### Soils

The region is characterized by soft, black, red, stony, sandy soil which is heavily leached during rainy season. The soils support the cultivation of a

variety of food and export crops (Ebenezar *et al.*, 2013).

## ECONOMIC ACTIVITIES

### Agriculture

Agriculture is the major occupation of the people in the South West Region. The main agricultural activity is crop farming dominated mostly by small holdings for both export crops and food crops. The type of crops produced can be grouped into cereals (corn, groundnuts, beans); tubers (coco yams, yams, cassava, and potatoes) which are staples), tree crops (plantains, banana, palm trees, mangoes, oranges, guava, plum, pawpaw, lime, lemon) and vegetables. The major export crops produced in the region include cocoa, coffee (*mangiferaindica*), banana (*Musa ssp*), tea (*Camellia sinensis*), rubber (*Heveabrazilenses*), and oil palm (*Elaeisguineensis*). Although most of the south west region supports the cultivation of these crops by corporations and peasant farmers, most of these crops cannot be produced in a vast area of Fako Division due to the presence of industrial tree plantation corporations which have deprived, disposed and displaced majority of peasants from their land holdings, thus greatly affecting their livelihood sources (Ngoe, 2020).

### Commercial Activities

There are no manufacturing industries in the South West Region. Trading is carried out with imports from Nigeria which shares both land and maritime boundaries with the region and also manufactured goods from Douala, the country's major industrial and manufacturing centre. Other trading activities are done with agricultural produce from rural areas to urban centres where there is ever-growing demand. Commercial activities are greatly hampered by poor road infrastructure which prevents effective distribution of goods and services, especially food items for domestic consumption like root and tuber crops, fruits and vegetables which are highly vulnerable to postharvest losses. Some of the goods traded in the region include imported food, textiles, drinks, electronic equipment, machinery, spare parts, meat, and frozen chicken, most of them imported from western countries and Asia.

### Fishing

Fishing in the South West region is mostly done in the maritime areas of the west coast areas of Fako Division and the Bakassi peninsula in Ndian Division. Fishing on rivers has been greatly hampered by the presence of waterfalls and cataracts which impede movement of fishing boats and canoes. The main rivers in the region are Ndian, Meme, Manyu and Mongo.



## FAUNA AND FLORA

### Fauna

The following indigenous animals of the equatorial rain forest origin are available in the forests of the region: chimpanzees, monkeys, gorillas (cross river gorilla and western lowland gorilla), porcupines, deer, Duiker, cutting grass, hare, rat mole and insects (Ajayi *et al.*, 2015), most of these animals are located in areas or forests which have not been tempered by human activities. Studies by Ajayi (2015), support that these animals migrate from areas with extensive human activities such as logging, bush burning and deforestation in general because of the destruction of their natural habitat. Birds identified in the South West forest include the white-necked pigeon (*Columbia*), Green breasted bush-strike (*Malcanottus gladiators*), necked picarthartes (*Picathortesoreas*) etc., reptiles and amphibians. Species of fauna include frogs, toads, lizards, chameleon, large frogs such as Conrauarobusta, Trichobatrachus robots in forests of Dikome Balue and Bosunga Balue in Ndian Division. Crocodiles, alligators and fish are found in big rivers notably the mungo, Meme, Ndian, and Manyurivers including the Atlantic Ocean. Other fauna include the pythons, vipers, and green snakes (Ajayi *et al.*(2015). There is massive migration of these animals from deforested zones to those areas not affected by human activities in the region.

### Flora

Indigenous plants are many including some rare species which have been located in the forest reserve areas in the region. Trees are used as source of wood for energy, construction, furniture and for medicinal and food purposes. A large number of forest trees bearing fruits and seeds used for food, medicines and cultural rights exist in the forests of Manyu, Ndian, Kupe Manenguba, and Meme Divisions (Daniel *et al.*, 2016). Most of these trees and plants species are growing extinct in parts of Fako Division like Tiko and Limbe Subdivisions due to large scale deforestation by Industrial Tree Plantations(ITP) and small scale farming on both export and food crops. The plant species include “njangsa” (*Ricinodendronheudelotii*), “white peper” (*Piper nigrum*), “country onion” (*Afrostryaxlepidophyllus*), “bush mango” (*Irvingiagabonensis*), “bitter kola” (*Garcinia kola*) and safou (African plums) (*Dacryodesedulis*). The trees are only found in forests of Meme, KupeMwanenguba, Ndian, Manyu and parts of Lebialem Divisions. Most of these trees have been threatened with extinction by human activities notably deforestation and logging and efforts are being made to domesticate them through agro forestry (Daniel *et al.*, 2016). Other common species of trees found in the region include mahogany, iroko, sappele, bobinga, buma etc. Most of these trees have

domestic uses and are of highly demand for timber export to the industrialized countries (Garity, 2014; Dawson *et al.*, 2013).

## DATA COLLECTION

### Primary Data Sources

Primary data was obtained by organising working sessions using interview guides with officials of council areas affected by the Industrial Tree Plantations (CDC), organising working sessions using focus group discussion guides with village heads, notables and traditional authorities. Field workers were also randomly interviewed during work period in the plantations while they were purposely selected in the workers camps. Qualitative information was obtained through hanging out with workers in their camps where observation was done with respect to hygiene and sanitation, sources of water supply, areas of sewage and waste disposal, health facilities, recreational facilities, toilets, and schools.

### Secondary data

Secondary data was obtained through documentation of existing literature on CDC obtained from the corporations head office in Bota-Limbe and review of literature related to industrial tree plantations on journals, textbooks, and websites. It also entailed a review and analysis of relevant theories, concepts and empirical facts generated from other research findings on industrial tree plantations, including information on gender issues in the corporation’s documentaries.

## RESULTS AND DISCUSSIONS

### Examination of CDC effect on socioeconomic activities/human populations

Most communities in Cameroon depend on the forest resources for means of livelihood. The forest is used for hunting, energy sources from wood, medicine, construction works, cultural activities and agriculture. In this study a series of activities were affected in the human settlements and workers residential areas. Most workers camps and other human settlements are surrounded by the CDC plantations as observed in Tiko, Limbe, Mutengene, Buea, Ekona, Idenau and Mondoni areas. According to respondents the activities of CDC affects its workers living conditions and third parties. Poor living conditions observed in workers camps have been responsible for the mass exit of workers from camps to neighbourhood settlements as experienced in Tiko, Limbe, Batoke and others. Population pressure in Tiko has been responsible for the construction of homes in marshy and unwholesome areas around the seashore. In Limbe the same population pressure has been responsible for construction of houses on hills and other high risk



areas officially forbidden for human habitation in Cameroon because of inadequate land for housing resulting from CDC occupation. The situation is not different in Mbonge where the town has been completely surrounded by the CDC rubber plantation. Forests are very far from the workers camps and other settlements with the result that people especially the urban poor who still depend on forests for livelihood means trek for long distances in search for farmlands. The most precarious situation is that the few available areas for agriculture are not motorable. People have to carry food and wood for long distances from farms to their homes.

It was observed that recreation facilities are seriously lacking, especially for junior staff, women, and youths living in most of CDC workers camps. According to respondents' boredom and overuse of alcohol, sex and drugs are common in most workers camps; while casual and commercial sex has been commonly aggravated by low incomes and generalised poverty in the camps. Casual and commercial sex in camps has aggravated the incidence of sexually transmitted diseases (STDs) like HIV/AIDS among others. Most infrastructures for recreation like table tennis, swimming pools, and clubs are meant for high income workers like managers, engineers, and medical doctors including other skilled workers in the high income brackets. It was observed that low income workers have no access to such facilities especially as they are not located within their vicinity.

### **Effect on sources of energy**

Energy sources available to urbanites include electricity and wood. Most of the rural areas lack electricity supply. Where electricity is available it is only limited for lightening of homes and refrigeration as residents are unable to afford to use the modern source of energy for cooking. Consequently most urbanites still depend on wood energy for cooking as only a limited number of household can afford the use of gas and electricity for cooking and other chores. It was observed that workers camps suffer from endemic energy problems as most camps are not supplied with electricity and worker depend on lantern and candles for lightening homes. Giving that income level of the plantation workers are generally low, most workers use dry branches of rubber or palm for cooking when wood is inaccessible. Deforestation has led to increase cost of wood for population in urban areas, workers camps and rural areas affected by activities of the Cameroon Development Corporation in Fako Division.

### **Destruction of flora and fauna**

Cultivation of food in most of Fako Division is on marginal land or patches of land left uncultivated by the CDC and other actors in deforestation. According to respondents the Cameroon

Development Corporation have reserve land for future plantation expansion that could benefit communities and relieve them from energy and food supplement but forbids workers and third parties from harnessing resources from these reserve lands for their well-being. Most often legal action is taken against any individual or group who trespasses in the reserve land. The corporation usually destroys food crops planted by residents on marginal lands and reserve areas without notification to the farmers. As a result of these unchecked human rights abuses by the corporation there is limited food supply in the study area and, high cost of food as most food items consumed in cities like Limbe, Tiko, and Buea are brought from other parts of the South West Region, North West and from those areas of Fako Division which have not been affected negatively by the activities of the corporate farmers. In the same vain other food items like bush meat are hardly found in the deforested areas of the Division. The destruction of fauna resulting from abusive deforestation by industrial tree plantations have made many animals and birds and snakes extinct in most parts of Fako Division. Migration of these animal species which used to serve as source of meat has caused increased in the cost of bush meat as only privileged households can afford. To counter some of the negative effects of food shortages in Fako some residents are getting engaged in urban agriculture where food crops are cultivated on marginal patches of land left by the CDC and animal husbandry like poultry farming, piggery and fish farming.

### **Effects on expansion of settlements**

One of the greatest problems resulting from unchecked expansion of agro industries in Cameroon is the negative impact on urban expansion and high cost of building land, building materials and accommodation. In Fako Division the disappearance of forests as a result of deforestation has affected the construction of low cost wooden houses due to the high cost of wood. Most of the wood used for construction is brought from distant forests and other areas of the South West Region. According to studies by Ngoe and Yaya (2016) on Improving Urban habitat in Cameroon, the cost of building wooden structures and even furniture has increased tremendously that most people prefer to construct cement bricks houses than wood houses which were relatively cheaper for most income groups in the municipality. The same study advised that to prevent the escalating cost of building land and rental accommodation the Fako councils should pressurize CDC to give up some of its land holdings for urban expansion. In a focus group discussion in Mondoni village it was revealed that CDC released part of the land for expansion of the village due to increasing population but the land was all sold to rich and





privilege individuals leaving those in the low income bracket with no plots of land.

### **Deforestation and traditional health care**

According to World Health Organisation (2013) about 80% of inhabitants of African countries depend on traditional medicines for the treatment of most diseases. This dependence on traditional medicines may not necessarily be as a result of poverty and inability to afford modern medical treatment. It is believed that there are several diseases and illnesses that cannot be contained by modern medicines in villages studied. In Tiko and Moquo, the herbicides and pesticides used by CDC has led to the disappearance of plants species which were used for the treatment of diseases in the area. Some plants like yellow leaves used as blood medicine, fever grass use for the treatment of fever and enangajoh which is used for the treatment of ring worm and other skin diseases etc. are extinct and cannot be found in the community again.

This means that deforestation and destruction of vast ecosystems is affecting the continents healthcare delivery system. The destruction of both flora and fauna as a result of expansion of corporate farms will spell devastating consequences on the health of consumers of traditional medicines unless adequate steps are taken in the continents domestic policies and strategies. Traditional medicines embody the use of both plant and animal species while their absence will affect most practices and create unemployment among the practitioners. In Fako Division deforestation has affected the practice of traditional medicines in most indigenous settlements. According to some respondents in Moquo village in Mondoni there are no indigenous practitioners of traditional medicines in the village. They testified that most traditional healers have died without passing on the knowledge to their children or relatives due to the extinction of rare species of plants and animals. They resented the extinction of the elephant in the area because there are many medicinal plants whose seeds must pass through the alimentary canal of the elephant and other animals like the porcupine and the rate mole in order to retain their medicinal properties when they germinate. According to these respondents, action must be taken in other places where deforestation has not showed its ugly manifestations so that many plants and animal species will be preserved for future generations.

### **Deforestation and cultural practices**

Cultural practices and their manifestations are the pillars of African social life. The destruction and extinction of cultural practices destroys the moral fabric of every society while the society losses its identity (Oriega, 1992). Societies are known even in contemporary Africa because of the extent to which cultural heritage and practices are withheld by people

in their different communities. Each community must have a forest reserved for cultural activities where masquerades are dressed or where members of village cults manifest their activities before exposing them in village centres during festivals for people to see, admire and even encourage youth to enrol in the cults. It was observed that deforestation by CDC has left most villages without cultural identities due to the destruction of secret forests. These observations were made in similar studies by Karumbidza (2006) in Kwazulu Natal province of South Africa where industrial tree estate had destroyed both the social and economic life of the population. Demands for indemnities by the affected populations were greeted with violence and suppression from the South African government. .

According to a sixty-five year cultural advocate in Mondoni village destruction of secret forests dates back to the days of colonialism when secrets forests were regarded as places for pagan worship and did not see reasons for their existence in African communities. It is regrettable that in more than twenty villages affected by corporate farming activities none could boast of a reserve forest for cultural manifestation. Again in Ekona it was revealed that the sacred forests reserved for the performance of the Marley dance and other cultural festivals had been destroyed regardless of cultural consequences to the inhabitants.

The *Marley* dance which is also called the “elephant” dance was reported to be a very great festival involving all the *Bakweri* villages. According to the respondents who were mostly indigenous Bakweri people, Marley is a god of the people who used to be appeased through the activities carried out during festivals. It was revealed that a night before the festival was to be organized the traditional leaders consulted their god in order to seek solutions to problems encountered in the land. During the night of consultations everybody was expected to stay indoors as violators paid heavy fines in the form of money including domestic animals. Most often violators who refused to pay in fines were punished by the gods.

In Moquo village an informant recounted that: *“The company dug up our ancestral graves and planted bananas on them regardless of spiritual consequences. Perpetuators of these acts were said to have suffered and died from strange diseases which were difficult to diagnose in any health care unit”*.

Also the heterogeneous nature of the Moquo populations attributed to the influx of non-indigenes with different cultures have brought a mixed heritage in workers camps and the affected villages as the non-indigenes came with their own cultures and today they is a mixture of cultures in the areas where the CDC plantations are located. Due to this mixture of cultures, most people have been off rooted of their cultures and traditions with Christian practices more dominant among. Due to the dominance of





Christianity and disappearance of forests for cultural manifestations both indigenes and non-indigenes have little time (except weekends) for cultural manifestations. Respondents also revealed that traditional wrestling which used to be a cultural activity for entertainment among the indigenous communities is declining in the absence of cultural revivals. It was revealed that secret places for men to discuss community issues have been moved to the chief's palace due to disappearance of the forest while the cultural week and village play grounds where traditional dance competition used to be organized have completely disappeared. These results are a reflection of studies by Miller (2008) on African secret societies and Cuba where expansion of industrial trees and establishment of industries lead to destruction of people's heritage.

### Land dispossession and consumption patterns

One of the greatest problems resulting from deforestations and dispossession of farmland in Cameroon is changes in consumption patterns of the indigenous populations in both town and village settlements. Fako Division ranks among the most cosmopolitan Divisions in the South West Region due to the existence of employment opportunities in the Division. CDC workers camps are highly heterogeneous and serve as melting point of many cultural practices including food and nutritional requirements. According to the respondents most workers camps are plagued with series of problems with no solution envisioned. The indigenous people have found it difficult to maintain their cultural patterns due to deforestation and loss of farm land. Thus the supply of traditional food items like coco yams, plantains and yams which are staple to the indigenous people of the Division has reduced in most markets while the cost of the staples are being inflated in the wake of scarcity. Many people cannot afford for cocoyams which used to be a staple in the sixties and seventies as testified by a more than seventy five year old man at Idenau. To balance the nutritional deficiency many people have gone into the consumption of food items like maize, potatoes produced out of the South West Region. These analyses have been supported in studies by Norah (2021) on the Culture of food crop Production in Nweh, South West region of Cameroon where other food crops are cultivated alongside the traditional staples to balance nutritional deficiency in the subdivision.

The consumption of these crops is also influenced by the fact that many people in the Division are adopting new food types and food habits of people who have settled in the Division. Many of these food items are now being cultivated in marginal lands not affected by CDC activities and other areas in Fako Division which have not been significantly

affected by corporate activities. These results are in line with studies by (Serah *et al*,2018) and (Andrianto *et al*, 2014) in Paraguay and Brazil respectively over farm and grazing land acquired from peasants without compensation given to indigenous people.

### The plantations and factory environment.

Workers in factories visited were made up of the management staff, skilled and the unskilled workers called field workers. This category of workers are mostly unskilled labour implicated in activities such as gathering, welding, harvesting, intra-field transportation, and occasionally drivers who transport rubber or oil palm fruits and bunches into the factories. Majority of the unskilled labourers work in high risk marshy areas where they are exposed to snakes, mosquitoes and occasionally wild animals. Field work observation indicates that most workers in high risk areas and operations are not given protective clothing like boots, hand gloves and suitable clothing to protect them from harmful organisms. Respondents testified that the last time workers were given protective facilities in the company was in the late eighties and nineties. We however noticed that the most protected categories of workers are field managers, and headmen who supervise work on the plantation. Respondents explained that several workers have been victims of snake bites and attacks by other animals and insects around plantation areas which share boundaries with protected and reserve forests where the animals live. Cases were reported wherein workers died of snake bites due to the absence of transport facilities to evacuate sick patients for medical treatment. Plantation accidents are known to be common in oil palm plantations than rubber estates because animals like snakes and rat moles eat palm nuts. Encounters with snakes were revealed to be common in plantations near rivers like the Mungo and Meme river banks where plantations share boundaries with the river banks. It was revealed that during rainy seasons when the rivers are flooded the corporation losses revenue from unharvested crops as there are no embankments separating the rivers and plantations to prevent floods from entering plantations. Harvesting is therefore often suspended till the flood subsides.

One of the greatest sources of environmental problems in plantation is soil and water contamination from aerial sprays. Most human settlements are located within the plantation vicinity are victims of aerial sprays and noise pollution emanating from aircraft which affect residents and water around the settlements. In Moquo village it was observed that the buffer zone separating the banana plantation and the village from the effects of aerial sprays is only twenty five meters instead of one kilometre as standard distance (prescribed by WHO). In some communities informants revealed that CDC does not respect its 200 metres that is supposed to



serve as buffers between the plantation and human settlements. Consequently, chemicals used for aerial spraying in banana plantation were said to affect human settlements especially children who usually observe or play during chemical spraying on the plantation. It was revealed in Moquo village that aerial sprays affected sources of drinking water like wells and springs due to the absence of portable water. It was revealed that aerial sprays affected the rearing of domestic animals like goats and sheep as they eat contaminated grass and die from chemical contamination. Death of domestic animals by chemical sprays has destroyed sources of income generation and rendered the people poorer.

According to the study the real impact of aerial sprays like soil and water contamination could only be made know when studies are carried out to ascertain the degree of water and soil contamination by aerial sprays as this is beyond the scope of the study. It is therefore necessary to carry out an environment and social impact assessment involving soil and water sampling around the facilities and compare with World Health Organisation standards for pollution.

### The factory environment and human activities

Factory installations create undesirable environmental problems to human settlements, plants and animals when left unchecked by appropriate authorities through legislation. Factories emit gaseous and untreated effluent which are released in the air or channelled into water sources and farmlands with devastating consequences to sustainability of the environment. It was observed that most factory installations of the corporation channel untreated effluent in the sea or rivers as the case of CDC rubber factory in Tiko which is located in the middle of Tiko town and workers residential areas. The most abusive element of its location is the stench odour emanating from the factory which has remained chronic to residents of Tiko in the areas. Nick-named "Tiko perfume" the odour has become a salient characteristic of that vicinity of the town felt by visitors and residents. The impact of this odour containing oxides of sulphur and nitrogen (SO<sub>2</sub>, SO<sub>3</sub> and NO<sub>2</sub>) respectively is yet to be determined though the social, economic and environmental impacts are visible. Effluent from most factories has been channelled into creeks of the Atlantic Ocean where fish and other marine or aquatic organisms have likely been affected.

**Figure 4&5: Waste oil in untreated effluent channelled to the land and water**



Source: Ngoe Fritz and Norah Aziamin on Social and environmental assessment of agro-industries in Cameroon (2016).

Figure 4 and 5 shows untreated effluent discharged into land and water. The effect of effluent on marine and soil organisms cannot be determined in this study because the instruments are beyond the scope of this study.

Also the present study on CDC has been limited to social issues because it was not empowered with the necessary instruments to embark on soil and water sampling including ambient air monitoring to determine the impact of emissions to plants and animals including aquatic life in the affected areas. To reduce environmental effects from liquid waste some oil palm factories have developed catchments

designed to filter out waste oil from effluent for human consumption, notably for the production of soap commonly called "coco soap".

One of the best management practices identified in the factories was risk management with respect to outbreak of fire and security of the environment. Most or all factories visited have fire extinguishers and alarm instruments which go operational during fire incidents in the factory. It was equally realized that security at the entrance of every facility prevented arson from enemies who find it difficult to penetrate the factory unnoticed. However there were some risk operations that workers were



discovered without appropriate wears. Workers who filled fire wood into boilers were not protected from heat stress, a situation which could lead to fatal health diseases and death if unattended to.

### **Housing and accommodation in workers camps**

One of the greatest problems affecting workers in the CDC workers environment is the poor housing situation in workers camps. Except in case where residential areas are constructed as a result of development of new plantations, most of the workers camps were inherited from the German and British colonial masters at a time when population growth and migration did not constitute a problem. Residential areas for low income workers have never reflected household occupation. Allocation of residential quarters is not based on the number of household occupants but by work category with skilled workers allocated the best accommodation while the unskilled and semi-skilled workers who constitute the largest proportion of workers in the company's labour force have the lowest category of accommodation in term of facilities for decent life. Meanwhile it is this category of workers who have the highest number of household occupants or larger families. Labourers and their families live in single

room apartments where cooking, sleeping, eating is done. It was observed that most of the single rooms are divided by curtains which cover the bed from the other areas which can be used as a sitting room for leisure and dining. Most of the rooms can hardly accommodate assets like dining table and chairs. Most of the houses were provided with a kitchen attached to the single room. As household demand for space increases some workers obtain permission to construct attachments with Indian Bamboos or wood as sleeping rooms for children or strangers or as business premises. The space provided on the corridors for cooking and laundry is inadequate while children have no place reserved as play grounds within the camp vicinity. It was revealed that a single room could contain between six to eight occupants especially when the occupants are couples with children. It is worthy to understand as revealed by respondents that the corporation housing and accommodation policies have not altered significantly from the colonial era. A similar situation was revealed by EMIS (2013) report on Environmental and social impact assessment for Pamol; another industrial tree plantation located in Ndiang division of the south west region.

**Figure 1: Extension of wooden houses in Ekona yard CDC workers camp.**



*Source: Ngoe and Norah (2016) on Social assessment of agro-industries in Cameroon.*

Studies by Ngoe and Manu (2016) on HIV/AIDS and Commercial Agriculture in Cameroon revealed that children develop deviant behaviour in the congested homes due to inadequate privacy as moral issues are hardly taken into consideration during house allocation to workers. Frustrations and poverty manifests in heavy drinking and drunkenness among male and female workers on pay days. Immorality and infidelity are expressed in teenage pregnancies and

divorce. The use of drugs and unprotected sex are common and this has aggravated the spread of sexually communicable diseases like HIV/AIDS according to statistics revealed to CNE-MINRESI (2009) on HIV/AIDS and Public sector performance. The results of these studies indicated high prevalence of sexually transmitted diseases. Ignorance and lack of awareness was revealed as greatest factor responsible for the spread of HIV/AIDS in the company workers camps.





### Hygiene and sanitation in workers camps

Inadequate housing in Cameroon Development Corporations in workers camps reflects the state of hygiene and sanitation. Most CDC worker camps are provided with portable water. However the inability to construct new residential quarters or embark on innovations from

the existing colonial structures remains a cause for concern. Toilets are also provided but overused due to high number of families allocated per toilet. Most of the toilets constructed since the colonial periods are filled as no innovations are carried out to improve on their poor sanitary conditions. Besides, cleaners rarely attend to their daily tasks and most of the toilets are abandoned with workers seeking alternative places to defecate as shown below.



**Figure 2& 3: Unkempt and abandoned toilets at CDC Ekona camp.**

The surrounding of most toilets visited were environmentally unfriendly with swamps of flies from excreta and human faeces spotted at every corner of the toilet building in uncleared grass. It was revealed that residents in workers plantations suffer from air and water borne diseases attributed to the neglected environment. Among the diseases identified were malaria, typhoid, yellow fever, cough and skin diseases. These results are a reflection of earlier studies by EMIS (2011) on environmental audit for Pamol Cameroon Ltd. The study revealed that the prevalence of disease in workers camps was partly attributed to the environmentally unfriendly nature of their residential areas.

### CONCLUSION

The Cameroon Development Corporation (CDC) is the largest agro-industrial complex and next employer of labour after the Cameroon government. The corporation has vast estates of rubber, oil palms plantations, tea estates and banana plantation including facilities for processing oil palm and rubber. Although CDC has created employment opportunities in Cameroon and Fako division in particular it has created social, economic and environmental problems detrimental to third parties.

Occupying more than half of the land mass of Fako division the corporation has occupied vast areas of land through deforestation and cultivation of industrial trees. The major disadvantage of its presence in Fako division is that areas of land meant for food production and human settlement expansion have occupied by its estates, thus reducing food supply and increasing cost of accommodation. Consequently affected town or settlements in Fako division depend on food supplies from other regions and divisions of Fako which are not affected by activities of industrial plantations.

Secondly all CDC factory installations produce solid and liquid waste including gaseous emissions and sound detrimental to the environment and harmful to human health and other organism and therefore limiting productive activities in the affected areas as revealed by this study. Untreated effluent channelled into sources of water, the soil and farmlands remain a great cause for concern which requires government intervention in both policy and strategies. In addition, aerial sprays in plantation have revealed disastrous consequences in human settlements including workers residential areas as observed in the study. The prevalence of diseases associated to environmental problems on land and



water is an indication that the company is yet to give environmental issues the concern they deserve in all affected areas.

Thirdly the housing conditions of the company's workers has revealed deepening inequalities and even a violation of human rights as houses are allocated on the basis of rank and not on the number of households. It was revealed that congestion and inadequate space in living homes where couples and their children share the single rooms have been accountable to deviant behaviour among residents and the advent of sexually transmitted diseases such as HIV/AIDS among others. Inadequate housing facilities have resulted to the construction of attachment homes to relieve workers from the burden of accommodation shortages.

Finally hygiene and sanitation conditions with respect to water supply and toilets condition were observed as deplorable. Most of the toilets were unkempt and environmentally unfriendly as most workers preferred to defecate out of the toilet or the nearby estates given rice to provocative odour that may be contagious to residents.

### Recommendations

This study advances the following recommendations

- 1) There is need for government and its agencies to put pressure on CDC to give up land for urban expansion and food production to reduce the cost of food and rentable accommodations in the affected settlements
- 2) The Cameroon development corporations must construct new residential homes which reflect household occupation rather than ranks in the corporation. This will reduce congestion and improve hygiene and sanitation in the workers camps including the spread of communicable conditions among residents
- 3) All settlements affected by CDC activities should be granted social benefits in education, health, water supply and electricity as most of the settlement lack these facilities.
- 4) The need to carry out environmental impact and social assessment studies to determine the real impact of waste products channeled on plants and animals including human activities.
- 5) There is urgent need to equip workers in high risk operations with necessary clothing to prevent them from the effects of weather conditions, snake and insect bites and from heat stress as the case of factory workers.

### REFERENCES

1. Acquah E.T., Nganje W.Evange (2014). *The Economics of yams(Dioscoria ssp) production in Cameroon. the case of Fako Division. International Society of Horticultural Science*
2. Ajayi, O.C., F. Akinnifesi, G. Sileshi, S. Chakeredza, S. Mng'omba, O. Ajayi, I. Nyoka, and T. Chineke. (2008): *Local solutions to global problems: the potential of agroforestry for climate change adaptation and mitigation in southern Africa. Tropical Forests and Climate Change Adaptation (TroFCCA) Regional meeting "Knowledge and Action on Forests for Climate Change Adaptation in Africa," 18-20 November, Accra, Ghana.*
3. Andrianto, A.; Sedik, B.F.; Waridjo, H.; Komarudin, H.; Obidzinski, K. (2014). *The impacts of oil palm plantations on forests and people in Papua: A case study from BovenDigoel District, Paper-UR, Publication.*
4. Asaah E.K (2011): *Trees, agro-forestry and multifunctional agriculture in Cameroon, Yaounde*
5. Baromey Neth , Sam Ol Rith, Makoto Yokohari (2012), *Development without Conformity: Impacts of Large-Scale Economic Development on Indigenous Community Livelihoods in Northeastern Cambodia, International Journal of Environmental and Rural Development.*
6. *Cameroon Development Corporation annual reports (2017)*
7. *Environmental Management Initiative and Strategies(2010-2013). Report on Environmental impact and Social assessment for Pamol Installations in Ndiang Division, South West Region of Cameroon.*
8. Ebenezar K. Asaah, ZacTchoundjeu, Leakey RRB, TakoutsingBertin2011Trees, *agroforestry and multifunctional agriculture in Cameroon, (2011) International Journal of Agricultural Sustainability 9(1):110-119*
9. Dawson, Frank Place, Emmanuel Torquebiau, EricMalézieux, Miyuki Iiyama, Gudeta W Sileshi, Katja Kehlenbeck, Eliot Masters, Stepha McMullin, Ramni Jamnadass (2013): *Agroforestry, food and nutritional security. Background paper for the International Conference on food security. Rome.*
10. *Economic and political weekly (2010): Industrial Tree Plantations in the Global South*
11. Ivor .M. Miller (2008). *Voice of the Leopard: African Societies and Cuba.University of Mississippi Press*
12. Karumbidza J.B (2016). *A study of Social and Economic Impact of Industrial Tree Plantations in the Kwazulu Natal Province of South Africa. Montevideo World Forest Movement*
13. Garrity D.P.( 2004): *Agroforestry and the achievement of the Millennium Development Goals. Agroforestry Systems 61: 5-17.*
14. Ebenezar K. Asaah, ZacTchoundjeu, Leakey RRB, TakoutsingBertin2011Trees, *agroforestry and multifunctional agriculture in Cameroon, (2011).*





- International Journal of Agricultural Sustainability* 9(1):110-119
15. Ingram V., Van Der Werf E , E. Kikulwe E and. Wesseler J.H.H (2014), *Evaluating the Impacts of Plantations and Associated Forestry Operations in Africa—Methods and Indicators*, *International Forestry Review*, 18(1):44-55., Commonwealth Forestry Association.
  16. Ngoe Fritz Eseokwea (2020). *An assessment of postharvest losses of Cassava (Manihot esculenta) in the South West Region of Cameroon; unpublished PhD Thesis, University of Dschang*
  17. Ngoe Fritz Eseokwea and Mary Yaya (2015). *Constraints in Ameliorating Urban Habitat in Cameroon: Case of Buea Municipality. The international Research Publication: Research Journal of Social Sciences and Management (RJSSM), Vol 4, N° 11.*
  18. Njukwe Emmanuel, O. Onadipe , Damao, R ;Hanna, Hirscht, B. Maziyi-Dioxons, A. Mbairanodjou and T.Ngue-Bassa 2014. *Cassava Processing among small-holder farmers in Cameroon; Challenges and opportunities. International Journal of Agricultural Policy Research. 2 (4): 113-124*
  19. Norah Aziamin Asongu (2021). *The culture of food crop production in Nweh, South West Region of Cameroon; A contribution to Anthropology of Development; unpublished PhD thesis University of Yaounde I*
  20. Sarah E. Brown, Daniel C. Miller, Pablo J. Ordonez & Kathy Baylis(2018); *Evidence for the impacts of agroforestry on agricultural productivity, ecosystem services, and human well-being in high-income countries: a systematic map protocol, Environmental Evidence volume 7, Article number: 24 (2018)*



# ASSESSMENT THE MORAL DON'TS IN THE NEWS SERVICES OF LOCAL TVS IN BAGHLAN

Ansarullah Omari

Article DOI: <https://doi.org/10.36713/epra7287>  
DOI No: 10.36713/epra7287

## SUMMARY

*Research subject (review of moral don'ts in the news service of Baghlan local TV). The question of the research is how local TV stations in Baghlan act in order to avoid moral don'ts in their news services? Moral don'ts, in fact, are the red lines in the field of individual and social ethics that obliges journalists to refrain from them in preparing news and reports. The aim of this study is to understand the commitment of journalists of Baghlan local TVs in refraining from ethical don'ts in producing news productions. The importance of the research is that the journalists and officials of the local TV stations in Baghlan, by studying it, should identify the moral don'ts in news service and make efforts to eliminate them, and this will lead to the advancement of ethical journalism.*

*Among the variables or moral don'ts (desecration, distortion of facts, promotion of slavery, and involvement in criminal and political issues, psychological warfare, sexual abuse, racial discrimination, ethnic discrimination and linguistic discrimination) have been studied in the Baghlan local TVs news services. The important findings of the study are that the relationship between four variables (desecration, distortion of facts, racial discrimination and ethnic discrimination) are meaningful in Baghlan local TVs news services; that its two variables (racial discrimination and ethnic discrimination) are common in all three TV stations (Baghlan National, Pasban and Tanwir) and the other two variables are only meaningful on Pasban TV.*

*The present article is based on the theory of social responsibility. In the theory of social responsibility, the media accept and implement certain obligations in society, including refraining from moral don'ts. The research method is a quantitative research method of survey or field type. The statistical population is Pul-e-Khumri city and the sample population were selected using non-random (targeted) sampling.*

**KEYWORDS:** *ethics, media ethics, television, news service, moral don'ts*

## 2. INTRODUCTION

The social status of journalists in modern societies stems from their social duties and responsibilities. Telling the truth and defending the rights of citizens' freedoms is one of the most vital needs of the people in a democratic society, and these goals are taken care of and protected by journalists through professional activity and (considering moral values).

In order that citizens' rights not to be ignored by the media and discriminated against (racial, ethnic and linguistic), the functioning of the media must be subject to media laws and ethical principles; Because, by doing so, the media, on the one hand, can fully enjoy their rights and privileges, On the other hand, their journalists clearly cannot abuse their professional rights and privileges, and this helps to promote ethical (professional) journalism (1).

Violating and disregarding professional ethics (observing moral dos and avoiding moral don'ts) by the media has become a global concern today; because, the development of information technology on the one hand has become a social and cultural capital and on the other hand has circulated a large amount of this information among people in different societies. Recognizing the fact that in today's world, every citizen has access to information, information is one of their basic needs, and they use information to improve their quality of life. Therefore, it was concerned the world community about the accuracy, trusteeship (adherence to moral dos and avoidance of moral don'ts) in gathering news and preparing accurate reports. However, the important issue in the present study is that the news and reports of local TV stations in Baghlan are not provided correctly and with full trust and local TV reporters in Baghlan do not avoid from moral don'ts in producing their media products.

The aim of this study is to obtain the commitment of Baghlan local TV reporters to refrain from ethical requirements in producing news products. This research is also of particular importance in terms of application;



it means, the journalists and officials of the local TV stations in Baghlan can identify the avoiding moral don'ts in news service and try to eliminate them.

### 3. THE AIMS OF THE RESEARCH

1. Receiving the commitment of local TV stations journalists in Baghlan for avoiding moral don'ts in producing news product.

### 4. RESEARCH QUESTION

1. How do the local media of Baghlan act in avoiding moral don'ts in their news service?

### 5. THEORETICAL FOUNDATIONS

This research has been done based on theoretical foundations of media; particularly, the theory of social responsibility. Setting up an article on this theory is effective and efficient for its scientific understanding. This theory is important because that the reporters must not only adhere to individual and social ethics in doing media work; rather, they are committed to the observance of moral dos and it refrains from committing moral don'ts. "Normative theories tell how ideological values and situations are formed and function in certain cases." Normative theory is important; because, the formation of media institutions and how they are run by media owners have major effects" (2).

Normative theories explain the do's and don'ts of governing the media in different situations. These theories, which are binding and obligatory, have emerged from the condition of the media in different societies and times. These theories delineate the relationship between government, media, and society, and examine government expectations of the media, norms, conditions, and expectations regarding the social role of the media in different societies (3)

Social responsibility theory is a type of normative media theory that says; the media have fundamental duties in society and they must be committed to doing so, and finally the media must accept certain commitments about society and implement them (4). Therefore, in this study, we seek to find out how much local TV stations in Baghlan are committed to avoiding moral don'ts.

### 6. RESEARCH METHOD

Research Method of the present paper is the quantitative method research of survey type. Quantitative research is in fact the representation and manipulation of observations in order to describe and explain the phenomena that those observations reflect (5).

#### 6-1: Technique and Statistical Population of Research

In the present study (Tanwir, Pasban and Baghlan national TV) are dependent variables, which are calculated and measured with independent variables (sacrilege, distortion of facts, entering racial, ethnic and linguistic, criminal discrimination, promoting Promiscuity, psychological warfare, misusing sexual crimes). The method of information collection is field or survey method. The information in this research have collected through questionnaires and the number of acceptable questionnaires are (133).

The statistical population of the study is Pul-e-Khumri city. The sample population have selected, using non-random (purposeful) sampling. In purposeful sampling, the units which are going to observe or study, selected based on the researcher's judgment about which units are more useful and reference. Information from the research was collected through questionnaires and was analyzed by SPSS program.

### 7. RESEARCH BACKGROUND

The title of the investigation (review of moral don'ts in the news service of Baghlan local TV stations) has not been determined yet; however, the authors, such as: Javideh Ahmadi wrote a book with entitled in 2011 (Principles of Media Ethics) which has eight chapters and its content is mostly devoted to general cases of ethics. Manijeh Bakhtari also wrote a book in 2007 with a entitled (Ethics and Law in Journalism) in seven chapters in which the author has studied the concept of ethics. Bakhtiari also has a proposal to prepare a moral charter for the country's media.

However, foreign writers have done a great deal of scientific work on media ethics, and the researcher points to several studies in this regard: Mohammad Haji Esmaili, Master of Hadith Sciences, majoring in Ethics, Quran and Hadith University, in 2014, has prepared an article entitled (Criteria of Islamic Ethics in Journalism), and in his/her research, he identifies seven ethical issues, which are: Not receiving bribes, fiduciary, honesty and avoiding lies, refraining from divulging secrets, refusing to enter people's privacy, social responsibility and correct worldview and job statu.

Mohammad Fouladi, another Iranian researcher, wrote an article in 2009 entitled (Journalistic Ethics; Injuries and Challenges). Fuladi, In his researches, states moral dos(Prominent virtues, telling the facts,



trustworthiness and confidentiality, observance of intellectual property rights, observance of impartiality, being updated and correct analysis of issues, and contributing to the stability and mental peace of society) and considers (sacrilege, misusing Public confidence, distortion of facts and censorship, promoting corruption and Promiscuity, promoting rumors, psychological warfare and entering privacy) as moral don'ts. Fuladi, found cases Such as (dependence on sources of power and wealth, stealing scientific works, the role of organizational values and orientations in the selection of news, the role of power and wealth agent in news coverage, lack of employment of journalists in the media, publishing news with unknown sources, misusing criminal and sexual offenses and provoke ethnic and racial differences) as harms to journalism.

## 8. RESEARCH LITERATURE

### 8-1 Ethics

Amid dictionary has expressed the meaning of the collective morality of "creation" and its meaning as "good". The term "Akhlagh" is the English translation of "ethics" and refers to a rational process in which individuals apply a set of principles and criteria set by an external authority. In other words, ethics includes the do's and don'ts that, from a professional ethics perspective, oblige the journalist to observe.

Morality is also a set of principles and rules; Expresses the moral do's and don'ts in which there is a kind of independence from the person; such as: principles such as good and truthfulness and badness and lying that people learn from families or teachers and rely on society in some way and as a tool in the hands of society that is imposed on individuals, Morality in this sense is a social matter (6).

### 8-2: Media Ethics

Media ethics is a set of ethical principles, work and professional standards and individual commitments that form a structural and conceptual framework for the purpose of doing valuable professional work and guiding journalists and the activists of reporting arena to comply with ethical standards. Media ethics, in a real and practical way, does not only include the principles and criteria designed and presented by institutions and governments; Rather, media ethics involves knowing, understanding, and practicing ethical principles and concepts related to journalism and information work that help journalists and information activists in doing practical work so that they can do their work in a right and to agree with the principles of media ethics (7). Also, "media ethics" means introducing the theoretical framework that media owners are required to adhere to, so that adhering to its rules will eventually lead to practical ethics (8).

### 8-3. Moral don'ts

In addition to observing individual and collective ethics and respecting the moral values of society, journalists must also adhere to moral don'ts and refrain from committing them. Moral don'ts are the red line in the field of individual and social ethics that journalists are required to adhere to.

#### 8-3-1: Desecration

Amid dictionary expresses the meaning of sanctity as follows: "What is not allowed to break or what is obligatory to maintain and protect and ". However, deception, harassment, invasion of privacy, misuse, abuse of subjects and people who have been oppressed, magnification of conflicts, suicide attacks, criminal incidents, Sexual assault and ... It all comes down to sacrilege . Therefore, the media should not desecrate their activities (9).

#### 8-3-2: Distortion of facts

The media sometimes chooses news in order to achieve its internal goals; Pursue a policy of distorting the facts or selectivity of the news in various forms and abusing public trust; like the:

1. Zoom in on small facts to hide larger facts;
2. Denying or deleting a part of the truths of a subject, in order to distort the whole truth;
3. A fact with its specific analysis to distort the essence of the subject.
4. Expressing the truth and combining it with various lies to erase the effects and its result
5. Choosing words with a negative connotation to tell a valuable truth;
6. Inducing special political, economic, social, cultural, historical and scientific ideas in the form of (news and reports);
7. Destroying prominent, educated and influential personalities and promoting corruption

News and media reports are not only useful for all people due to their specific orientation; on the contrary, it has many effects, consequences and dangers. Although media messages are distorted; however, over time, the audience will believe their messages and follow their goals in the future, willingly or unwillingly (10).



### 8-3-3: Getting involved in criminal and political issues

Analyzing political issues is a good thing; However, sometimes, instead of observing balance and neutrality in political issues and correct analysis of political and social realities due to belonging to a stream, the reporter propagates his/her policy and in practice Promotes, schism, divisions and destruction of individuals and streams, etc. in the society and this action is against the public Expediency of the society.

That criminal and political issue are always tense; the reporter must observe accuracy, fairness and impartiality (10). In this regard, Article 22 of the Afghan Public Media Law is subtitled (Balancing) Regarding political issues, he says: "Private radio and television departments should strike a balance between the factions and political figures taking a stand against each other and broadcast the views of the parties impartially"

### 8-3-4: Promoting Promiscuity

Afghanistan is an Islamic country and in an Islamic society, Adherence to values, norms, public decency, respect for individuals and respect for the privacy of individuals, the prohibition of divisions and differences between individuals, the avoidance of hypocrisy and hypocrisy is important and desirable; Therefore, the Promoting Promiscuity of red lines and moral musts in an Islamic society is considered and the media are required to observe them (9).

### 8-3-5: Psychological warfare

Psychological warfare is "to mass communication in modern political conflicts: the use of violence and more conventional methods of communication to achieve politico-military goals (11). Currently, the media is the most important weapon for creating and streamlining psychological warfare and is used for purposes (political, military, economic, cultural, etc.); If journalists and reporters of news media, publish news and reports (correct, true, neutral and with the aim of creating an atmosphere of social belonging), the society will be moved towards empathy and The more the publication of news and their reports is far from reality and the incorrect attribution of articles in order to create an artificial atmosphere, the more it inflames the public space of society (10).

### 8-3-6: Abuse of Sexual Crimes

Abuse of people in any situation; it is an immoral act. Journalists and the media should not misuse people with dossiers related to sexual offences; Even if this act is not illegal, publishing the names, pictures of people, especially injured women, etc. is against chastity, ethics and public interests in an Islamic society. This is not only moral; but, the media law prohibits such information in order to destroy the personality of individuals at the community level; Therefore, journalists and the media should not mention the names of Sexual assault victims or publish material that reveals their identities; Unless there is no legal prohibition in this area (9).

### 8-3-7: Racial Discrimination

The media and journalists publish articles, directly or indirectly, that incite or cause war, violence, hatred and racism. Divisive issues among different groups of people, under any title, are considered wrongdoing, crime and immorality. The Afghan Constitution has such a view in this regard: (Any kind of discrimination and privilege between Afghan citizens is prohibited) (12).

### 8-3-8: Ethnic and Linguistic Discrimination

Journalists Because of belonging to a particular ethnic group and language defend them and take a stand against other ethnicities and languages. The media must refrain from inciting prejudice among the ethnic groups and languages of the country (10).

## 9. RESEARCH FINDINGS

### 9-1. Description of research findings

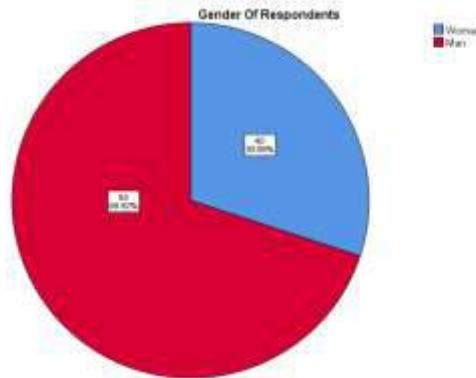
In this study, the researcher used a questionnaire as a data collection tool. According to the questions raised in the questionnaire, the most important research findings in the frequency distribution tables are described in the following table:

Gender of respondents		Frequency	Percent	Valid Percent	Cumulative Percent
Gender of respondents	Woman	40	30.1	30.1	30.1
	Man	93	69.9	69.9	69.9
	Total	133	100.0	100.0	



Table1: According to the frequency of number (1) out of (133) respondents, the highest number of respondents (69.9%) percent or (93) men and the lowest number of respondents (30.1%) percent or 40 female.

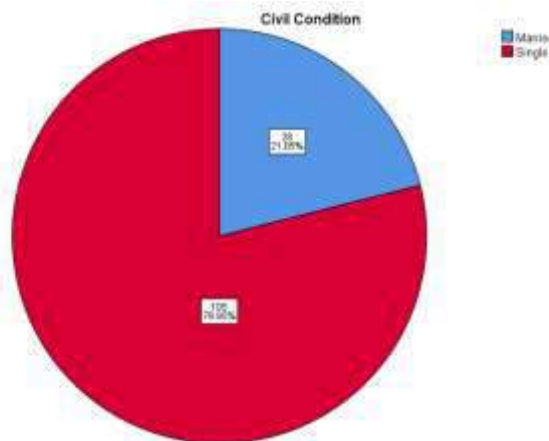
**Graph No (1):**



Civil condition		Frequency	Percent	Valid Percent	Cumulative Percent
Civil condition	Married	28	21.1	21.1	21.1
	Single	105	78.9	78.9	100.0
	Total	133	100.0	100.0	

Table2: According to the frequency table, number (2) of the total (133) respondents, the highest respondent (78.9%) percent or (105) single and the lowest number of respondents (21.1%) percent or (28) people are married.

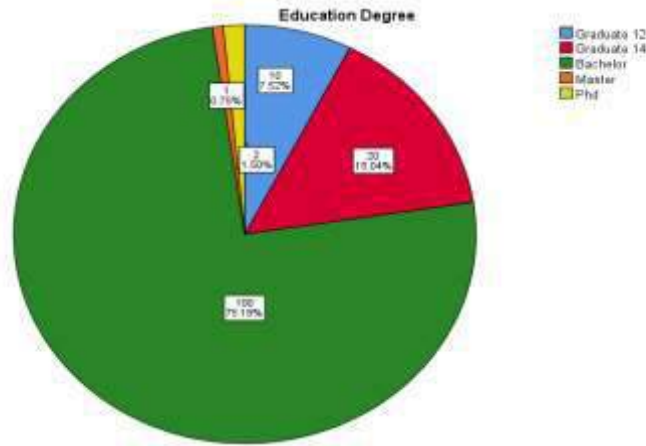
**Graph No (2):**



Education degree		Frequency	Percent	Valid Percent	Cumulative Percent
Education degree	Graduate12	10	7.5	7.5	7.5
	Graduate14	20	15.0	15.0	22.6
	Bachelor	100	75.2	75.2	97.7
	master	1	.8	.8	98.5
	P.H.D	2	1.5	1.5	100.0
	Total	133	100.0	100.0	

In table3: According to the frequency table number (3) from the total of (133) respondents, the most respondent (75.2%) percent or (100) people with a bachelor's degree, (7.5%) or (10) graduate 12, (1.5%) percent or (2) P. HDs and the lowest number of respondents, (0.8%) percent or (1) have a master's degree.

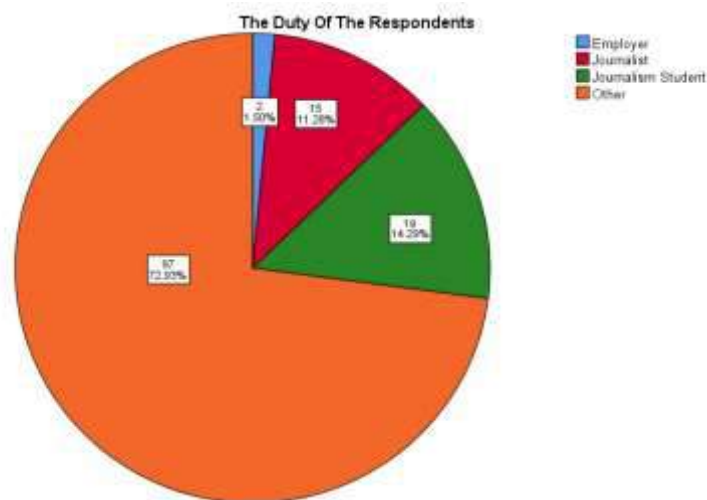
**Graph No3:**



The duty of the respondents		Frequency	Percent	Valid Percent	Cumulative Percent
The duty of the respondents	employer	2	1.5	1.5	1.5
	annalist	15	11.3	11.3	12.8
	Journalism student	19	14.3	14.3	27.1
	Other	97	72.9	72.9	100.0
	Total	133	100.0	100.0	

Table NO4: according to the frequency table NO(4) out of (133) respondents, the highest number of respondents(72.9%) percent or (97) people have various duties, (14.3%) percent or (19) are journalism students, (11.3%) percent or (15) were local media reporters, and (1.5%) percent or (2) people are employers.

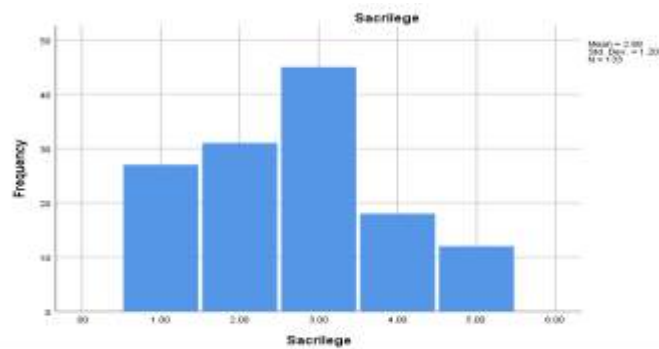
**Graph NO 4:**



Sacrilege		Frequency	Percent	Valid Percent	Cumulative Percent
Sacrilege	Very little	27	20.3	20.3	20.3
	little	31	23.3	23.3	43.6
	average	45	33.8	33.8	77.4
	many	18	13.5	13.5	91.0
	perfectly	12	9.0	9.0	100.0
	Total	133	100.0	100.0	

Total5: According to table5, in terms of sacrilege in the news service of Baghlan TVs, out of a total of (133) respondents, the highest response rate (33.8%) or the average response rate (45) is medium and the lowest response rate (9.0%) percent or (12) people is a very high option.

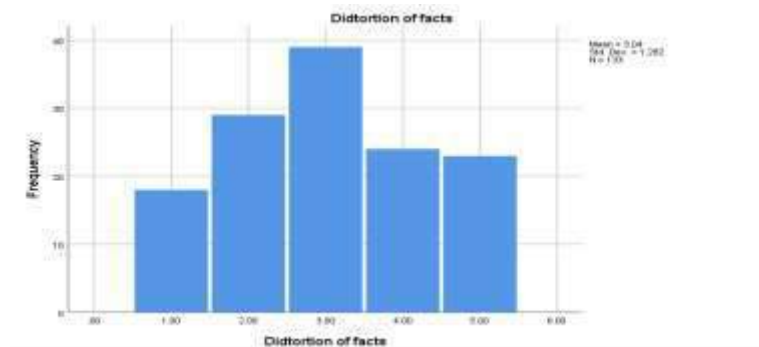
**Graph (5):**



Distortion of facts		Frequency	Percent	Valid Percent	Cumulative Percent
Distortion of facts	Very little	18	13.5	13.5	13.5
	Little	29	21.8	21.8	35.3
	Average	39	29.3	29.3	64.7
	Many	24	18.0	18.0	82.7
	Perfectly	23	17.3	17.3	100.0
	Total	133	100.0	100.0	

Table 6: according table 6, in terms of fact-finding in the news service of Baghlan local TVs, out of a total of (133) respondents, the highest response rate is (29.3%) or the average response rate is(39)and the lowest response rate(13.50%) percent or (18) people is a very small option.

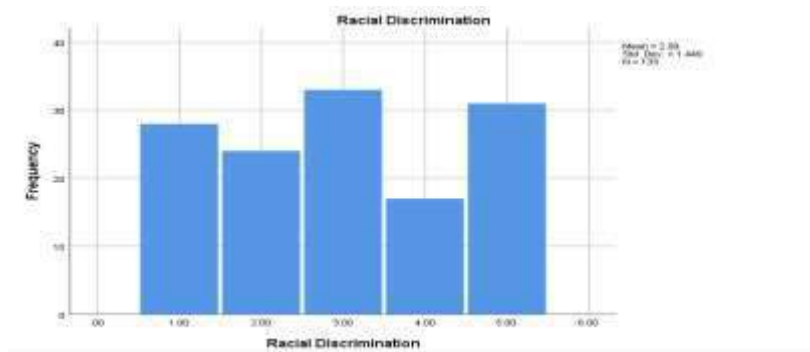
**Graph (6):**



Racial discrimination		Frequency	Percent	Valid Percent	Cumulative Percent
Racial discrimination	Very little	28	21.1	21.1	21.1
	Little	24	18.0	18.0	39.1
	Average	33	24.8	24.8	63.9
	Many	17	12.8	12.8	76.7
	Perfectly	31	23.3	23.3	100.0
Total		133	100.0	100.0	

Table NO7: according to table NO(7), in terms of racial discrimination in the news service of local TVs in Baghlan, out of a Total of (133) respondents, The highest response(23.3%) percent or (31) people is a very high choice and the lowest response (12.8%) percent or (17) people is a high choice.

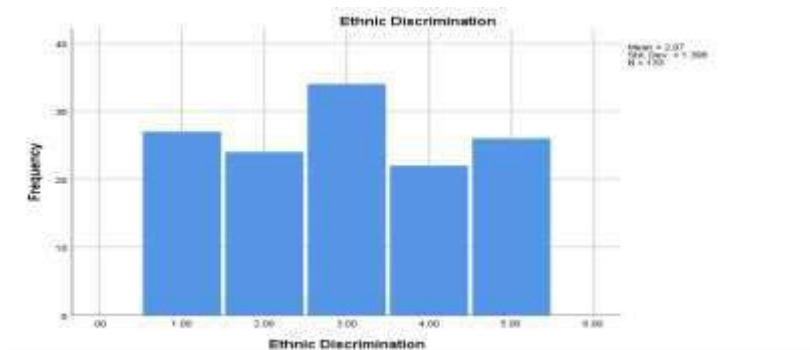
**Graph NO7:**



Ethnic Discrimination		Frequency	Percent	Valid Percent	Cumulative Percent
ethnic discrimination	Very little	27	20.3	20.3	20.3
	Little	24	18.0	18.0	38.3
	Average	34	25.6	25.6	63.9
	Many	22	16.5	16.5	80.5
	Perfectly	26	19.5	19.5	100.0
Total		133	100.0	100.0	

Table NO8: according to table NO(8) in terms of ethnic discrimination in the news service of local TVs in Baghlan, out of total of (133) respondents, the highest response(25.3%) percent or (34) people is the average option and the lowest response (19.5%) or (26) people is the very high options.

**Graph NO (8):**





**9-2: Analysis of Research Findings**

In the present study (national television, Tanvir and Pasban) are dependent variables with independent variables (desecration, distortion of facts, involvement in criminal and political issues, Promoting Promiscuity, psychological warfare, sexual abuse, racial discrimination, Ethnic discrimination and linguistic discrimination) have been studied.

Hypothesis 1: There seems to be a relationship between Tanvir local television and the fact that there is racial discrimination in the Baghlan local television news service.

**Table 1. The relationship between Tanvir local TV and the fact that there is racial discrimination in the news service of Baghlan local TV.**

The relationship between Local enlightenment TV and ethical needs		Racial discrimination on Tanvir local TV					Total	
		Very little	Little	Average	Many	Perfectly		
Racial discrimination	Very little	Count	6	1	10	7	4	28
		Line percent	21.4%	3.6%	35.7%	25.0%	14.3%	100.0%
		Colum percent	23.1%	4.2%	20.8%	38.9%	23.5%	21.1%
		Total	4.5%	0.8%	7.5%	5.3%	3.0%	21.1%
	Little	Count	2	4	10	6	2	24
		Line percent	8.3%	16.7%	41.7%	25.0%	8.3%	100.0%
		Colum percent	7.7%	16.7%	20.8%	33.3%	11.8%	18.0%
		Total	1.5%	3.0%	7.5%	4.5%	1.5%	18.0%
	Average	Count	6	7	14	3	3	33
		Line percent	18.2%	21.2%	42.4%	9.1%	9.1%	100.0%
		Colum percent	23.1%	29.2%	29.2%	16.7%	17.6%	24.8%
		Total	4.5%	5.3%	10.5%	2.3%	2.3%	24.8%
	Many	Count	5	6	6	0	0	17
		Line percent	29.4%	35.3%	35.3%	0.0%	0.0%	100.0%
		Colum percent	19.2%	25.0%	12.5%	0.0%	0.0%	12.8%
		Total	3.8%	4.5%	4.5%	0.0%	0.0%	12.8%
	Perfectly	Count	7	6	8	2	8	31
		Line percent	22.6%	19.4%	25.8%	6.5%	25.8%	100.0%
		Colum percent	26.9%	25.0%	16.7%	11.1%	47.1%	23.3%
		Total	5.3%	4.5%	6.0%	1.5%	6.0%	23.3%
Total	Count	26	24	48	18	17	133	
	Line percent	19.5%	18.0%	36.1%	13.5%	12.8%	100.0%	
	Colum percent	100.0%	100.0%	100.0%	100.0%	100.0%	100.0%	
	Total	19.5%	18.0%	36.1%	13.5%	12.8%	100.0%	

Chi-Square Tests			
	Value	Df	Asymptotic Significance (2-sided)
Pearson Chi-Square	26.438 <sup>a</sup>	16	.048
Likelihood Ratio	30.742	16	.015
Linear-by-Linear Association	1.558	1	.212
N of Valid Cases	133		

a. 14 cells (56.0%) have expected count less than 5. The minimum expected count is 2.17.

Table (1): The findings of the study show that there is a relationship with five percent error and 95 percent confidence between Tanvir local TV and that there is racial discrimination in the news service of Baghlan local TV according to the Chi-square test (26.438) and the degree of freedom (16). There is a



relationship with five percent error and 95 percent confidence; in other words, there is a connection between Tanvir local television and the fact that there is racial discrimination in the Baghlan local television news service. In describing this table, it should be said: in the variable of racial discrimination in the news service of local TV stations in Baghlan; In the very low option, the highest ratio is average and the lowest ratio is low. In the low option, the highest ratio is average and the lowest ratio is very high and very low. In the medium option, the highest ratio is average and the lowest ratio is very high. In the high option, the highest ratio is moderate and low and the lowest ratio is high and high. In the high value option, the highest ratio is very high and medium and the lowest ratio is high.

Hypothesis 2: There seems to be a significant relationship between Tanvir local television and ethnic discrimination in the Baghlan local television news service.

**Table 2, The relationship between Tanvir local television and ethnic discrimination in the Baghlan local television news service.**

The Relationship Between Tanvir Local TV and Moral don'ts		Ethnic Discrimination on Tanvir Local TV					Total	
		Very little	Little	Average	Many	Perfectly		
Ethnic Discrimination	Very little	Count	7	1	8	5	6	27
		Line percent	25.9%	3.7%	29.6%	18.5%	22.2%	100.0%
		Colum percent	26.9%	4.2%	16.7%	27.8%	35.3%	20.3%
		Total	5.3%	0.8%	6.0%	3.8%	4.5%	20.3%
	Little	Count	1	4	12	6	1	24
		Line percent	4.2%	16.7%	50.0%	25.0%	4.2%	100.0%
		Colum percent	3.8%	16.7%	25.0%	33.3%	5.9%	18.0%
		Total	0.8%	3.0%	9.0%	4.5%	0.8%	18.0%
	Average	Count	5	10	13	4	2	34
		Line percent	14.7%	29.4%	38.2%	11.8%	5.9%	100.0%
		Colum percent	19.2%	41.7%	27.1%	22.2%	11.8%	25.6%
		Total	3.8%	7.5%	9.8%	3.0%	1.5%	25.6%
	Many	Count	4	5	9	2	2	22
		Line percent	18.2%	22.7%	40.9%	9.1%	9.1%	100.0%
		Colum percent	15.4%	20.8%	18.8%	11.1%	11.8%	16.5%
		Total	3.0%	3.8%	6.8%	1.5%	1.5%	16.5%
	Perfectly	Count	9	4	6	1	6	26
		Line percent	34.6%	15.4%	23.1%	3.8%	23.1%	100.0%
		Colum percent	34.6%	16.7%	12.5%	5.6%	35.3%	19.5%
		Total	6.8%	3.0%	4.5%	0.8%	4.5%	19.5%
Total	Count	26	24	48	18	17	133	
	Line percent	19.5%	18.0%	36.1%	13.5%	12.8%	100.0%	
	Colum percent	100.0%	100.0%	100.0%	100.0%	100.0%	100.0%	
	Total	19.5%	18.0%	36.1%	13.5%	12.8%	100.0%	

Chi-Square Tests			
	Value	Df	Asymptotic Significance (2-sided)
Pearson Chi-Square	27.787 <sup>a</sup>	16	.034
Likelihood Ratio	30.065	16	.018
Linear-by-Linear Association	2.457	1	.117
N of Valid Cases	133		

a. 16 cells (64.0%) have expected count less than 5. The minimum expected count is 2.81.

Table No. 2: The research findings show that there is ethnic discrimination between the Tanvir and the Baghlan local television news service; according to the Chi-square test (27.787) and the degree of freedom (16), there is a relationship with five percent error and 95 percent confidence, or in other words, between Tanvir local television, there is a significant relationship between Tanvir local television and the fact that there is ethnic discrimination in the news service of Baghlan local television. In describing this table, it should be said: In the variable of ethnic discrimination in the news service of local TV stations in Baghlan; in the very low option, the



highest ratio is average and the lowest ratio is low. In the low option, the highest ratio is average and the lowest ratio is very high and very low. In the medium option, the highest ratio is moderate and the lowest ratio is very high. In the high option, the highest ratio is average and the lowest ratio is very high. In the high option, the highest ratio is very low and the lowest ratio is high.

Hypothesis 3: There seems to be a significant relationship between Pasban local TV and the fact that there is a sacrilege in the news service of Baghlan local TV.

**Table 3. The relationship between the local TV of the Pasban and the fact that there is a desecration in the news service of the local TV stations in Baghlan**

The relationship between the Local TV of the Pasban and ethical needs		sacrilege on Pasban local TV					Total	
		Very little	Little	Average	Many	Perfectly		
Sacrilege	Very little	Count	3	7	13	4	0	27
		Line percent	11.1%	25.9%	48.1%	14.8%	0.0%	100.0%
		Colum percent	14.3%	25.9%	25.5%	19.0%	0.0%	20.3%
		Total	2.3%	5.3%	9.8%	3.0%	0.0%	20.3%
	Little	Count	2	7	13	8	1	31
		Line percent	6.5%	22.6%	41.9%	25.8%	3.2%	100.0%
		Colum percent	9.5%	25.9%	25.5%	38.1%	7.7%	23.3%
		Total	1.5%	5.3%	9.8%	6.0%	0.8%	23.3%
	Average	Count	9	9	20	3	4	45
		Line percent	20.0%	20.0%	44.4%	6.7%	8.9%	100.0%
		Colum percent	42.9%	33.3%	39.2%	14.3%	30.8%	33.8%
		Total	6.8%	6.8%	15.0%	2.3%	3.0%	33.8%
	many	Count	3	4	3	4	4	18
		Line percent	16.7%	22.2%	16.7%	22.2%	22.2%	100.0%
		Colum percent	14.3%	14.8%	5.9%	19.0%	30.8%	13.5%
		Total	2.3%	3.0%	2.3%	3.0%	3.0%	13.5%
	Perfectly	Count	4	0	2	2	4	12
		Line percent	33.3%	0.0%	16.7%	16.7%	33.3%	100.0%
		Colum percent	19.0%	0.0%	3.9%	9.5%	30.8%	9.0%
		Total	3.0%	0.0%	1.5%	1.5%	3.0%	9.0%
Total	Count	21	27	51	21	13	133	
	Line percent	15.8%	20.3%	38.3%	15.8%	9.8%	100.0%	
	Colum percent	100.0%	100.0%	100.0%	100.0%	100.0%	100.0%	
	Total	15.8%	20.3%	38.3%	15.8%	9.8%	100.0%	

Chi-Square Tests			
	Value	Df	Asymptotic Significance (2-sided)
Pearson Chi-Square	31.343 <sup>a</sup>	16	.012
Likelihood Ratio	34.590	16	.005
Linear-by-Linear Association	1.225	1	.268
N of Valid Cases	133		

a. 16 cells (64.0%) have expected count less than 5. The minimum expected count is 1.17.

Table No. 3: The findings of the study show that there is a relationship with five percent error and 95 percent confidence between Tanvir local TV and that there is desecration in the news service of Baghlan local TV according to the Chi-square test (31.343) and the degree of freedom (16). In other words, there is a significant relationship between the Pasban local television and the desecration of facts in the Baghlan local television news service. In the desecration variable in Baghlan local TV news service; In the very low option, the highest ratio is moderate and the lowest ratio is very high. In the low option, the highest ratio is moderate and the lowest ratio is very high. In the medium option, the highest ratio is moderate and the lowest ratio is high. In the high option, the highest ratio is very high, high and low, and the lowest ratio is medium and very low. In the very high option, the highest ratio is very high and very low and the lowest ratio is low.



Hypothesis 4: There seems to be a significant relationship between the local Pasban television and distortion of the facts in the news service of the Baghlan local television.

**Total 4. There is a connection between the Pasban and the distortion of the facts in the news service of the local TV stations in Baghlan**

The relationship between Pasban TV and ethical needs		Distortion of the facts on the local TV of the Pasban					Total	
		Very little	Little	Average	Many	Perfectly		
Distortion of facts	Very little	Count	5	3	7	2	1	18
		Line percent	27.8%	16.7%	38.9%	11.1%	5.6%	100.0%
		Colum percent	23.8%	11.1%	13.7%	9.5%	7.7%	13.5%
		Total	3.8%	2.3%	5.3%	1.5%	0.8%	13.5%
	Little	Count	5	5	13	5	1	29
		Line percent	17.2%	17.2%	44.8%	17.2%	3.4%	100.0%
		Colum percent	23.8%	18.5%	25.5%	23.8%	7.7%	21.8%
		Total	3.8%	3.8%	9.8%	3.8%	0.8%	21.8%
	Average	Count	1	11	20	6	1	39
		Line percent	2.6%	28.2%	51.3%	15.4%	2.6%	100.0%
		Colum percent	4.8%	40.7%	39.2%	28.6%	7.7%	29.3%
		Total	0.8%	8.3%	15.0%	4.5%	0.8%	29.3%
	many	Count	4	4	5	6	5	24
		Line percent	16.7%	16.7%	20.8%	25.0%	20.8%	100.0%
		Colum percent	19.0%	14.8%	9.8%	28.6%	38.5%	18.0%
		Total	3.0%	3.0%	3.8%	4.5%	3.8%	18.0%
	Perfectly	Count	6	4	6	2	5	23
		Line percent	26.1%	17.4%	26.1%	8.7%	21.7%	100.0%
		Colum percent	28.6%	14.8%	11.8%	9.5%	38.5%	17.3%
		Total	4.5%	3.0%	4.5%	1.5%	3.8%	17.3%
Total	Count	21	27	51	21	13	133	
	Line percent	15.8%	20.3%	38.3%	15.8%	9.8%	100.0%	
	Colum percent	100.0%	100.0%	100.0%	100.0%	100.0%	100.0%	
	Total	15.8%	20.3%	38.3%	15.8%	9.8%	100.0%	

Chi-Square Tests			
	Value	Df	Asymptotic Significance (2-sided)
Pearson Chi-Square	26.375 <sup>a</sup>	16	.049
Likelihood Ratio	28.077	16	.031
Linear-by-Linear Association	1.759	1	.185
N of Valid Cases	133		

a. 16 cells (64.0%) have expected count less than 5. The minimum expected count is 1.76.

Table No. 4: The findings of the study show that there is a relationship with five percent error and 95 percent confidence between Tanvir local TV and that there is distortion of facts in the news service of Baghlan local TV according to the Chi-square test (26.375) and the degree of freedom (16). In other words, there is a significant relationship between the Pasban local television and the distortion of facts in the Baghlan local television news service. In the variable of distortion of facts in the news service of local TVs in Baghlan; in the very low option, the highest ratio is moderate and the lowest ratio is very high. In the low option, the highest ratio is moderate



and the lowest ratio is very high. In the medium option, the highest ratio is moderate and the lowest ratio is very high and very low. In the high option, the highest ratio is the maximum and the lowest ratio is the low and very low. In the very high option, the highest ratio is moderate and very low and the lowest ratio is high.

Hypothesis 5: There seems to be a significant relationship between Pasban local television and racial discrimination in the Baghlan local television news service.

<b>Total 5. The relationship between Pasban local TV and there is racial discrimination in the news service of Baghlan local TV</b>								
The relationship between Local TV and ethical needs		Racial discrimination on the Pasban local TV					Total	
		Very little	Little	Average	Many	Perfectly		
Racial discrimination	Very little	Count	2	6	11	5	4	28
		Line percent	7.1%	21.4%	39.3%	17.9%	14.3%	100.0%
		Colum percent	9.5%	22.2%	21.6%	23.8%	30.8%	21.1%
		Total	1.5%	4.5%	8.3%	3.8%	3.0%	21.1%
	Little	Count	1	5	10	6	2	24
		Line percent	4.2%	20.8%	41.7%	25.0%	8.3%	100.0%
		Colum percent	4.8%	18.5%	19.6%	28.6%	15.4%	18.0%
		Total	0.8%	3.8%	7.5%	4.5%	1.5%	18.0%
	Average	Count	2	8	17	5	1	33
		Line percent	6.1%	24.2%	51.5%	15.2%	3.0%	100.0%
		Colum percent	9.5%	29.6%	33.3%	23.8%	7.7%	24.8%
		Total	1.5%	6.0%	12.8%	3.8%	0.8%	24.8%
	many	Count	5	5	4	3	0	17
		Line percent	29.4%	29.4%	23.5%	17.6%	0.0%	100.0%
		Colum percent	23.8%	18.5%	7.8%	14.3%	0.0%	12.8%
		Total	3.8%	3.8%	3.0%	2.3%	0.0%	12.8%
Perfectly	Count	11	3	9	2	6	31	
	Line percent	35.5%	9.7%	29.0%	6.5%	19.4%	100.0%	
	Colum percent	52.4%	11.1%	17.6%	9.5%	46.2%	23.3%	
	Total	8.3%	2.3%	6.8%	1.5%	4.5%	23.3%	
Total	Count	21	27	51	21	13	133	
	Line percent	15.8%	20.3%	38.3%	15.8%	9.8%	100.0%	
	Colum percent	100.0%	100.0%	100.0%	100.0%	100.0%	100.0%	
	Total	15.8%	20.3%	38.3%	15.8%	9.8%	100.0%	

<b>Chi-Square Tests</b>			
	Value	Df	Asymptotic Significance (2-sided)
Pearson Chi-Square	30.770 <sup>a</sup>	16	.014
Likelihood Ratio	32.366	16	.009
Linear-by-Linear Association	4.923	1	.027
N of Valid Cases	133		

a. 15 cells (60.0%) have expected count less than 5. The minimum expected count is 1.66.

Table No. 5: The findings of the study show that there is a relationship with five percent error and 95 percent confidence between Tanvir local TV and that there is racial discrimination in the news service of Baghlan local TV according to the Chi-square test (30.770) and the degree of freedom (16). In other words, there is a connection between Pasban National Local Television and the fact that racial discrimination is present in the Baghlan Local Television news service. In the variable of racial discrimination in the news service of local TV stations in Baghlan; In the very low option, the highest ratio is the average limit and the lowest ratio is the very low limit. In the low option, the highest ratio is moderate and the lowest ratio is very low. In the medium option, the highest ratio is moderate and the lowest ratio is very high. In the high option, the highest ratio is the minimum and very low and the lowest ratio is the very high. In the highly priced option, the highest ratio is very low and the lowest ratio is high.

Hypothesis 6: There seems to be a significant relationship between Pasban local television and ethnic discrimination in the Baghlan local television news service.

**Table 6. The relationship between Pasban local TV and there is ethnic discrimination in the news service of Baghlan local TV.**

The Relationship Between Local enlightenment TV and ethical needs		Ethnic Discrimination On Pasban Local TV					Total	
		Very little	Little	Average	Many	Perfectly		
ethnic discrimination	Very little	Count	2	5	13	4	3	27
		Line percent	7.4%	18.5%	48.1%	14.8%	11.1%	100.0%
		Column percent	9.5%	18.5%	25.5%	19.0%	23.1%	20.3%
		Total	1.5%	3.8%	9.8%	3.0%	2.3%	20.3%
	Little	Count	1	6	10	6	1	24
		Line percent	4.2%	25.0%	41.7%	25.0%	4.2%	100.0%
		Column percent	4.8%	22.2%	19.6%	28.6%	7.7%	18.0%
		Total	0.8%	4.5%	7.5%	4.5%	0.8%	18.0%
	Average	Count	1	10	17	4	2	34
		Line percent	2.9%	29.4%	50.0%	11.8%	5.9%	100.0%
		Column percent	4.8%	37.0%	33.3%	19.0%	15.4%	25.6%
		Total	0.8%	7.5%	12.8%	3.0%	1.5%	25.6%
	many	Count	6	4	6	5	1	22
		Line percent	27.3%	18.2%	27.3%	22.7%	4.5%	100.0%
		Column percent	28.6%	14.8%	11.8%	23.8%	7.7%	16.5%
		Total	4.5%	3.0%	4.5%	3.8%	0.8%	16.5%
Perfectly	Count	11	2	5	2	6	26	
	Line percent	42.3%	7.7%	19.2%	7.7%	23.1%	100.0%	
	Column percent	52.4%	7.4%	9.8%	9.5%	46.2%	19.5%	
	Total	8.3%	1.5%	3.8%	1.5%	4.5%	19.5%	
Total	Count	21	27	51	21	13	133	
	Line percent	15.8%	20.3%	38.3%	15.8%	9.8%	100.0%	
	Column percent	100.0%	100.0%	100.0%	100.0%	100.0%	100.0%	
	Total	15.8%	20.3%	38.3%	15.8%	9.8%	100.0%	

Chi-Square Tests			
	Value	df	Asymptotic Significance (2-sided)
Pearson Chi-Square	39.211 <sup>a</sup>	16	.001
Likelihood Ratio	38.259	16	.001
Linear-by-Linear Association	2.845	1	.092
N of Valid Cases	133		

a. 15 cells (60.0%) have expected count less than 5. The minimum expected count is 2.15.

Table No. 6: The findings of the study show that there is a relationship with five percent error and 95 percent confidence between Tanvir local TV and that there is Ethnic Discrimination in the news service of Baghlan local TV according to the Chi-square test (39.211) and the degree of freedom (16). In other words, there is a connection between Pasban National Local Television and the fact that Ethnic Discrimination is present in the Baghlan Local Television news service. In the variable of ethnic discrimination in the news service of local TV stations in Baghlan; in the very low option, the highest ratio is the average limit and the lowest ratio is the very low limit. In the low option, the highest ratio is average and the lowest ratio is very high and very low. In the medium option, the highest ratio is moderate and the lowest ratio is very low. In the high option, the highest ratio is moderate and very low and the lowest ratio is very high. In the highly priced option, the highest ratio is very low and the lowest ratio is high and low.





Hypothesis 7: There seems to be a significant relationship between Baghlan local television and racial discrimination in the local television news service.

**Table 7. The relationship between Baghlan local TV and there is racial discrimination in the news service of Baghlan local TV.**

The Relationship Between Baghlan national local TV and moral needs		Racial Discrimination on Baghlan national local TV					Total	
		Very little	Little	Average	Many	Perfectly		
racial discrimination	Very little	Count	0	3	7	6	12	28
		Line percent	0.0%	10.7%	25.0%	21.4%	42.9%	100.0%
		Colum percent	0.0%	18.8%	25.0%	17.6%	26.7%	21.1%
		Total	0.0%	2.3%	5.3%	4.5%	9.0%	21.1%
	Little	Count	0	2	8	9	5	24
		Line percent	0.0%	8.3%	33.3%	37.5%	20.8%	100.0%
		Colum percent	0.0%	12.5%	28.6%	26.5%	11.1%	18.0%
		Total	0.0%	1.5%	6.0%	6.8%	3.8%	18.0%
	Average	Count	2	4	10	10	7	33
		Line percent	6.1%	12.1%	30.3%	30.3%	21.2%	100.0%
		Colum percent	20.0%	25.0%	35.7%	29.4%	15.6%	24.8%
		Total	1.5%	3.0%	7.5%	7.5%	5.3%	24.8%
	many	Count	2	3	2	3	7	17
		Line percent	11.8%	17.6%	11.8%	17.6%	41.2%	100.0%
		Colum percent	20.0%	18.8%	7.1%	8.8%	15.6%	12.8%
		Total	1.5%	2.3%	1.5%	2.3%	5.3%	12.8%
	Perfectly	Count	6	4	1	6	14	31
		Line percent	19.4%	12.9%	3.2%	19.4%	45.2%	100.0%
		Colum percent	60.0%	25.0%	3.6%	17.6%	31.1%	23.3%
		Total	4.5%	3.0%	0.8%	4.5%	10.5%	23.3%
Total	Count	10	16	28	34	45	133	
	Line percent	7.5%	12.0%	21.1%	25.6%	33.8%	100.0%	
	Colum percent	100.0%	100.0%	100.0%	100.0%	100.0%	100.0%	
	Total	7.5%	12.0%	21.1%	25.6%	33.8%	100.0%	

Chi-Square Tests			
	Value	Df	Asymptotic Significance (2-sided)
Pearson Chi-Square	27.181 <sup>a</sup>	16	.040
Likelihood Ratio	31.735	16	.011
Linear-by-Linear Association	1.333	1	.248
N of Valid Cases	133		

a. 12 cells (48.0%) have expected count less than 5. The minimum expected count is 1.28.

Table 7. The findings of the study show that there is a relationship with five percent error and 95 percent confidence between Baghlan local TV and that there is racism in the news service of Baghlan local TV according to the Chi-square test (27.181) and the degree of freedom (16). In other words, there is a connection between Baghlan National Local Television and the fact that racism is present in the Baghlan Local Television news service. In the variable of racial discrimination in the news service of local TV stations in Baghlan; in the very low option, the highest ratio is very high and the lowest ratio is very low. In the low option, the highest



ratio is high and the lowest ratio is very low. In the medium option, the highest ratio is high and medium and the lowest ratio is very low. In the large option, the highest ratio is very high and the lowest ratio is medium and very low. In the high value option, the highest (average) ratio is very high and the lowest ratio is medium.

Hypothesis 8: There seems to be a significant relationship between Baghlan local television and ethnic discrimination in the Baghlan local television news service.

**Total 8. The relationship between Baghlan national local TV and the fact there is ethnic discrimination in the Baghlan local TV news service.**

The relationship between Baghlan national local TV and moral needs		ethnic discrimination on Baghlan local TV					Total	
		Very little	Little	Average	Many	Perfectly		
ethnic discrimination	Very little	Count	0	2	8	6	11	27
		Line percent	0.0%	7.4%	29.6%	22.2%	40.7%	100.0%
		Colum percent	0.0%	12.5%	28.6%	17.6%	24.4%	20.3%
		Total	0.0%	1.5%	6.0%	4.5%	8.3%	20.3%
	Little	Count	1	0	7	10	6	24
		Line percent	4.2%	0.0%	29.2%	41.7%	25.0%	100.0%
		Colum percent	10.0%	0.0%	25.0%	29.4%	13.3%	18.0%
		Total	0.8%	0.0%	5.3%	7.5%	4.5%	18.0%
	Average	Count	2	6	10	9	7	34
		Line percent	5.9%	17.6%	29.4%	26.5%	20.6%	100.0%
		Colum percent	20.0%	37.5%	35.7%	26.5%	15.6%	25.6%
		Total	1.5%	4.5%	7.5%	6.8%	5.3%	25.6%
	many	Count	2	4	2	6	8	22
		Line percent	9.1%	18.2%	9.1%	27.3%	36.4%	100.0%
		Colum percent	20.0%	25.0%	7.1%	17.6%	17.8%	16.5%
		Total	1.5%	3.0%	1.5%	4.5%	6.0%	16.5%
	Perfectly	Count	5	4	1	3	13	26
		Line percent	19.2%	15.4%	3.8%	11.5%	50.0%	100.0%
		Colum percent	50.0%	25.0%	3.6%	8.8%	28.9%	19.5%
		Total	3.8%	3.0%	0.8%	2.3%	9.8%	19.5%
Total	Count	10	16	28	34	45	133	
	Line percent	7.5%	12.0%	21.1%	25.6%	33.8%	100.0%	
	Colum percent	100.0%	100.0%	100.0%	100.0%	100.0%	100.0%	
	Total	7.5%	12.0%	21.1%	25.6%	33.8%	100.0%	

Chi-Square Tests			
	Value	Df	Asymptotic Significance (2-sided)
Pearson Chi-Square	29.830 <sup>a</sup>	16	.019
Likelihood Ratio	35.407	16	.003
Linear-by-Linear Association	1.554	1	.213
N of Valid Cases	133		

a. 11 cells (44.0%) have expected count less than 5. The minimum expected count is 1.65.

Table (8): The findings of the study show that there is a relationship with five percent error and 95 percent confidence between Baghlan local TV and that there is Ethnic discrimination in the news service of Baghlan local TV according to the Chi-square test (29.830) and the degree of freedom (16). In other words, there is a connection between Baghlan National Local Television and the fact that ethnic discrimination is present in the Baghlan Local Television news service. In the variable of ethnic discrimination in the news service of local TV stations in Baghlan; in the very low option, the highest ratio is very high and the lowest ratio is very low.



## 10. DISCUSSION AND CONCLUSION

“Media ethics refers to the set of rules that media practitioners are required to follow voluntarily in the field of employment of their organizational professions” (13). Ethics is the broadest normative system that encompasses all levels of communication and no individual or social action is outside its scope. This research is based on normative theories of media; In particular, the theory of social responsibility has been done, which has important and useful results.

The most important result of this research are four cases of immorality, including (desecration, distortion of facts, racial discrimination and ethnic discrimination) in the news service of local TV stations in Baghlan. Racial discrimination and ethnic discrimination are common to all three local televisions (national, Pasbam, and Tanvir). The research findings show that these two variables are in the first row in Baghlan National TV, in the second row in Pasban TV and in the third place in Tanvir TV. In addition, Pasban TV also has a constable (desecration and distortion of facts). In addition, Pasban TV has included the constable (desecration and distortion of facts). As saw in the description and analysis of the findings, local TV stations in Baghlan face media ethics challenges. This article is aimed at getting the commitment of Baghlan local TV reporters to refrain from moral don'ts; it can pave the way for further research.

## 11: RECOURSES

1. Forghani, Mohammad Mehdi (1393). *Journal of Communication and Community Journalism*. Tehran: Ettelaat Publications.
2. Amirpour, Mahnaz and Shafi' Bahramian. (1392.) *General principles of mass communication theories*. Tehran: Sociologists.
3. Babran, Siddiqeh and others. (1394). *Charter of Professional Ethics in the Media*. *Quarterly Journal of Ethics in Science and Technology*. Tenth year. Fourth Issue.
4. McQuail, Dennis. (1385). *an Introduction to Mass Communication Theory*. Translation: Parviz Ejlali. Tehran: Ministry of Culture and Islamic Guidance.
5. Baaby, Earl. (1390.) *Research methods in social sciences*. Translation: Reza Fazel. Volume II. Seventh edition. Tehran: Organization for the Study and Compilation of University Humanities Books.
6. Bashir, Hasan. (1392). Tehran: Imam Sadegh University publications.
7. Sarwari, Abdul Qahar (1396). *Freedom of expression and journalistic ethics*. Kabul: Hamed Resalat Publications.
8. Bashir, Hasan and Samaneh Azarpoor. (1390). "Ethics of blogging". *Two Quarterly Journal of Interdisciplinary Studies in Media and Culture*. First year. Second Issue.
9. Fouladi, Mohammad (1388). *Journalistic ethics, injuries and challenges*. *Research Quarterly of bulletin of ethics*. First year. Number four.
10. Ahmadi, Javideh. (1390.) *Principles of media ethics*. Kabul: Azem Publications.
11. Simpson, Christopher. (1396). *Knowledge of communication and psychological warfare from 1945 to 1960*. Translation: Mohammad Memarian. Tehran: Scientific and Cultural Publications.
12. Bakhtari, Manijeh. (1389.) *Ethics and law in journalism*. Second edition. Kabul: Saeed Publications
13. Sharafuddin, Seyed Hussein (1392). *A religious approach to media ethics. With the focus on national media*. *Two specialized quarterly journals of Maarej Revelation Science Research Institute*. Second year. Fifth issue.



## CONTEMPORARY ART SCENARIO IN THE STATE OF ANDHRA PRADESH

**Dr. K. Mrutyunjaya Rao**

*Sr. Assistant Professor, Department of Fine Arts, Yogi Vemana University, Kadapa, Andhra Pradesh.*

Article DOI: <https://doi.org/10.36713/epra7344>

DOI No: 10.36713/epra7344

---

### ABSTRACT

*The Art activity in the state of Andhra Pradesh was pioneered by Damerla Ramarao and Varada Venkataratnam with the help some English officers and some of their disciples. Later whole art activity is concentrated at Hyderabad till the state bifurcation in 2014. The Art education and Institutions were discussed in details. The arrival of Baroda school product has helped us to mark our self as distinct school on the cultural map of India with help of Ravinder G Reddy, V.Ramesh, T.Sudhakara Reddy, CRS Patnaik and Dr. K.Mrutyunjaya Rao. These masters has succeeded to paved a bridge between art and Contemporary art of India. Later the product of Andhra art school has spreaded all over the state and country. Two art departments emerged in the region of Rayalaseema under the lead of Dr.K. Mrutyunjaya Rao. Due to state bifurcation, the major art activity and development has gone to Telangana. The Residual Andhra Pradesh has lost so much. Many of Andhra Artists settled at other states for bread and butter. But now recovering slowly.*

**KEY WORDS:** *Damerla Rama Rao , Baroda, Contemporary, Aesthetic, Scrap Sculpture, Kadapa,*

---

### INTRODUCTION

The activities of art in Andhra Pradesh can be witnessed in the areas of Telangana and costal Andhra as united Andhra Pradesh. The development of art activity in Andhra Pradesh can be classified in two phases for the convenience of the study. The former is an initial development done in Costal Andhra and focus moved later to Hyderabad as it was made capital of the state of Andhra Pradesh. Since the last quarter of the 18<sup>th</sup> century witnessed wonderful art activity in costal Andhra Pradesh under the Pioneership of Damerla Rama Rao. From 1940s onwards the art activity was focused at Hyderabad gradually shifted where the most of the artists migrated to for bread and butter along with their consistent efforts and experimentation in Art at Hyderabad which marked itself on the international map in respect of art activity with contribution of the telugu artists belongs to the all areas of Andhrapradesh. Soon after the independence, the art of Andhra has flourished in the hands of Laxma Gowd, P.T Reddy, PR Raju, Kapu Rajaiah, K.Seshagiri Rao, Vaikuntam Thota, DLN Reddy etc in Telangana region and G Ravinder Reddy, V. Ramesh at Andhra region in later times.



### Developments in Andhra Area

Activities of art can be viewed in Coastal Andhra Pradesh since 1920s. Damerla Rama Rao (1897-1925) (fig.1) was considered as the “Father of Modern Andhra Painting”. Being the product of JJ School of Art, Mumbai he has achieved an idiom that is the fusion of native Andhra themes with western forms. He was the founder of “*Andhra Bharatheeya Chitrakala Parishad*” an art society in 1915 and also started an Art school in 1921 in Rajahmundry by the direction of O.J Kuldre, the principal of Government Arts College, Rajahmundry<sup>1</sup>. O.J. Kuldre has encouraged them by introducing various idioms of their times. Varada Venkataratnam was appointed as the Principal to that art school. Under the leadership of Rama Rao, MS Prakash Rao, Varada Venkataratnam, VV Bhagiradhi (JJ School), Madeti Rajaji, Chamakur Venkata Satyanarayana, Ankala Venkata Subba Rao were excelled in combining the technique of academic naturalism and oriental wash technique of their teachers. All of their works were infused the spirit of nationalism with the impact of Bengal Revivalist art Movement. But gradually these artists were inclined to the Bombay school in term of modernity. Thus Damerla became the icon of Andhra Art. In 1925, the Bengal school sent Promod Kumar Chatterjee to head the National College of Arts at Machilipatnam who was succeeded by renowned artist Adavi Bapiraju. There was an attempt nearly seven decades ago to introduce the new spirit of painting in Andhra by services of a great Bengal artist Promod Kumar Chatterjee who taught at Andhra Jateeya Kalasala at Macheleapatnam from which gave raised the number of younger artists Anand Mohan Sastry, Adavi Bapi Raju, Gurram Mallaiah, A.V. Subba Rao, V.R Chithra, and others<sup>2</sup>.



Fig.1 Late Damerla Rama Rao

The another movement of painting was launched at Rajahmundry by Damerla Rama Rao who was taught and trained in the JJ school of Art at Mumbai. The two art movements are not rivals but experimented towards the synthesis of Art. Thus Both Chatterjee and Damerla Rama Rao have left their impressions on Andhra School of Art<sup>3</sup>. The college became the nexus for the new art movement. The art activity was gone out passively as the focus was shifted to Hyderabad. During Fifties to seventies the activity led by the Adiraju Subrahmanyam of Vijayanagaram, Rajaji, Vaddadi Papayya, CSN Patnaik student of Government College of Arts and Crafts his highly active in his medium Bronze with technically more perfect among the others.

The lyrical mysticism of art of Neo Bengal School to unimaginative realism of the Bombay School of Art. The artistic intention of both schools are different, in fact the comparison is odious; there was a much difference between them as there is difference between abstract philosophy and exact science. The contribution of Damerla Rama Rao is unforgettable on the cultural map of Andhra Pradesh who has struggled to develop a style of his own. He thought that art was dreamy, anemic and unnatural. He was too deeply immersed in the trammels of art tradition of Bombay school to break easily away from them. He sought inspiration from Greece and took much of mannerism from the works of Lord Leighton

This will reflect in his group setting of figures that closely followed by Lord Leighton. In his painting “Ajanta Vihara” is a the Indian theme but resembles Greek settings. The pillars of Ajanta were painted in the manner of Greek as if they in height rather than shorter and bulbous. It is felt that Rama Rao is not influenced by the

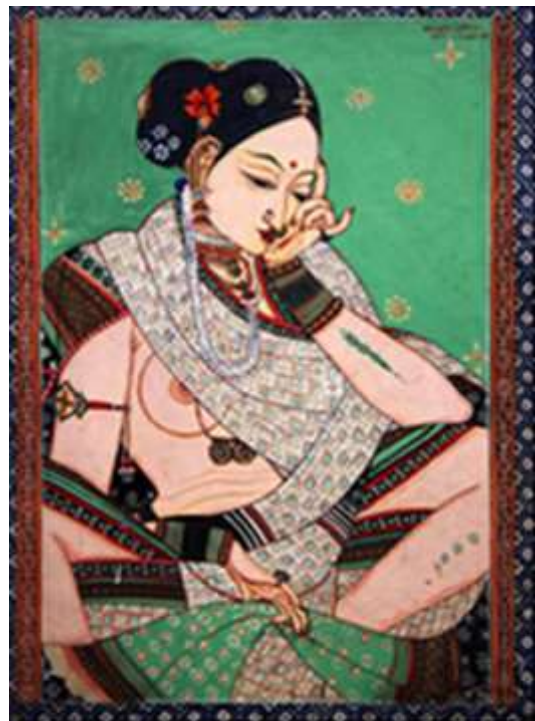


Fig.2. A Painting by A.Pydiraju





extraordinary beauties and striking poses of Ajanta women. The painting “Khatiyawar women at well “ is also resembles with dress , poses are typical Indian but the composition of groups are almost like Greek art. He Has intentionally ignored the symbolism , artistic anatomy , psychological perspectives and other conventions of Indian Art. A.P. Lalit Kala Academy was established at Hyderabad in 1960 under the president ship of Nookala Narothamma Reddy and Lakshminarayana Gupta<sup>4</sup> as the Secretary had its own Art Gallery, where annual art exhibits were conducted known as Kala Bhavan. Late it was wound up in 80’s.

The Art Scenario in Andhra Pradesh has really begun with the Department of Fine Arts at Andhra University , Visakhapatnam which was established in the year 1976<sup>5</sup> which has played pivotal role to make so many young artists from 90s, been acknowledged as a distinguished school of art at South as well as in India. In the initial days, the department was headed by Antyakula Pydiraju, Lakshmayya Choudhary. During the Seventies sri Antyakula Pydiraju was more active and gave fresh breeze and breath to art of Andhra with his folk style (fig.2). Later decades the dimensions of the department has been completely shaped into perfect academic institution on par

with other premier art institutions in India after the joining of Ravinder G Reddy, V Ramesh, T,Sudhakara Reddy, C. Ravishankar Patnaik, BM Das and Sistla Srinivas as the faculty members. In a period of a decade, their personal image in the contemporary art of India has fetched recognition and fame to department by inviting eminent artists and personalities to the department on various occasions and imbibed spirit amongst many students. Their personal and professional relations with

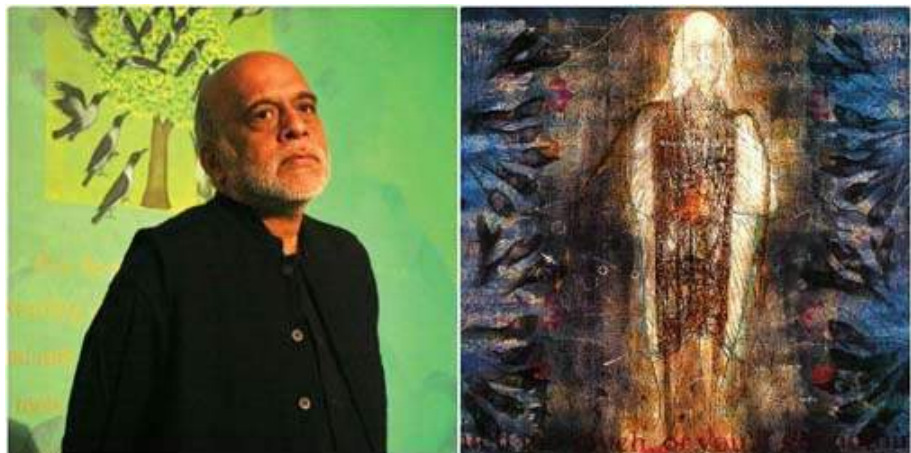


Fig.3 Ravinder G Reddy with his work

contemporary artists has helped to project the image of the department by inviting Bhupen Khakhar, Jyothi Bhatt, Nagji Patel, Balbir Singh Khatt, Madan Lal, K. Laxma Gowd, Rekha Rodwithya, Rm Palaniappan etc.

The massive sculptures of polyester rosin and gold leaf brought fame to Ravinder Reddy at International level. In the works of Ravinder Reddy, “female form” is mostly celebrated in large size heads with wide open eyes as Hindu goddesses. Each head is embellished with rich decoration(fig.3). We easily notice that symmetry is the fundamental in his works and they unfolds society’s gaze, as the way they perceive women.

Prof. V.Ramesh (fig.4) is one of the most celebrated artist, Icon of Andhra whose vibes touched the off the bays and inspired many students as eminent teacher. His large canvases painted over the past decade are the subject of curiosity and debate for



their unique concern with the idea of faith and renunciation in contemporary times. These two great personalities brought recognition to Andhra Pradesh in the field of Contemporary Art. Senior students of the department LNV Srinivas, Santhi Swaroopini, Dr.K.Mrutyunjaya Rao (fig.5), M.Venkatesam, D Simhachalam are heading the Fine Arts departments s the faculty in states of Andhra Pradesh as well as Telangana. K. Ravi contributed a lot to the art of Andhra with his numerous shows across India and abroad, now serving as teacher at



Department of Fine Arts, Andhra University. Young Sculptor Santosh Kumar Pedagadi took up teaching as his career at School of Planning and Architecture (SPA), Vijayawada and Printmaker Kurmanadham is working in NID, Vijayawada as Assistant Professor. B. Bhaskara Rao has achieved name for his element "Tree" across the country as his signature. Sculptor S.D Hari Prasad, hailed from traditional sculptor's family from Allagadda of Kurnool ( Rayalaseema) who later turned up as National Awardee from Lalit Kala Academy. R. Giridhar Gowd, the product of the Baroda school and CAVA who lives and works in a village in Tenali. He works continuously from last two decades. Gowd's work imbued with strong influence of Miniature and Mural paintings and preparation of the colours of his own with the inspiration of Banasthali. Vedala Ramakrishna of Vizianagaram is rendering his services as a Secretary of Lalit Kala Akademi, New Delhi. This school has acclaimed recognition for art especially in Printmaking under the supervision of T.Sudhakara Reddy who taught Printmaking, who took at most care during his teaching days at Andhra University. Young Printmakers Pratap Modi, Balaji Ponna Bandi Durga Prasad, Subhakar, Kurmanadham, Jagadeesh Tammineni. Jagadeesh Tammineni is one of the most talented Printmaker, a specialist in wood cut (fig.6) and Painters K.Ravi, MTPV Prabhakar, K.Mrutyunjaya Rao, B. Bhaskar, S.Surya Rao, M. Venkatesam, Maruthi Pyla, T.Kodanda Rao, T.Rajasekhar, Kanumuri Srinivas, Sculptors like Manmadha Rao, Satyanarayana, Vasupalli Appa Rao, SD.Hari Prasad, Kasturi Appalanaidu, Santosh Kumar Pedagadi (Fig.7), Abhishek Mandala, Syrus, Azgar Ali, Sabbavarapu Venkatesh, Sukarala Appala Raju, Srinivas Padakanadla, Ramakrishna Manyala, Ravichand, T.Govind, JSP Govind, A. Tirupati Rao, Kothuru Laxman Rao, Kodali Ravi, Srinivas Manda are very active and doing continuous work.



Fig.5 Drawing by K.Mrutyunjaya Rao



Fig.6 Wood cut by Jagadeesh Thammineni



Fig.7 A sculpture by P.Santosh





Since 2013, the passion for Automobile Scrap Sculpture is predominant in Andhra Pradesh. The above artists have participating in many Automobile Scrap Sculpture camps at places like Kurnool, Kadapa, Tirupati, Vijayawada, Visakhapatnam, Madhurai, Tanjore, Rajaasthan etc. Creative potential and meticulous work of JSP Govind in automobile scrap Sculptures brought him fame in Andhra Pradesh. There are plenty of women artists also occupied their space in the art of Andhra (fig.8). Women artists Mrs. Syeeda Ali, Shanti Swaroopini, Santi Siri, Sandhya Patnaik, Uma Vegesina, Roja Sanchana, Srilalitha Tekumalla, Divya Chinni, Sograh Khurasani, have acclaimed name through their works at International and National levels. Sograh Khurasani is a young and prominent woman artist in printmaking from Andhra Pradesh. She explores her thoughts of beauty and violence through digital print, text and videos. She composes landscapes in the form of skin, flesh, stain and scars with land, soil, valleys and mountains which are more aesthetic (fig.9). Students of this department soon raised to many heights in both Professional and Academic fronts in Andhra Pradesh and across India.



Fig.8 Automobile Scrap Sculpture by JSP Govind

In 1992, a group of Five artists appeared on the screen of art scenario of Andhra Pradesh with common ideology on art, popularly known as “Guntur Pandavas”, the term was coined by A.S Raman, the Chief editor of Illustrated weekly of India. The members included are Nagavardhan, Narasimha Rao, Vijaya Kumar, Raj Kumar and Osman Khan were very active at Guntur as the

center for their activity of art. It was led by Vijaya Kumar and supported by Chennai based artists Rajavelu and Adimoolam. After death of Nagavardhan in 1997, having divergent opinions, in the search of livelihood, the group was dispersed, finally ended up by 2004<sup>6</sup>. Kalagramam Village was established at Visakhapatnam with hardships of Ravinder Reddy G, Botch Venkata etc as the artistic Practice center and the lead of G. Ravinder Reddy and Ravi Shankar Patnaik, V.Ramesh T. Sudhakara Reddy. Art historian Sistla Srinivas and some young people are inculcating the spirit of art History amongst the younger generations.



Fig.9 A Woodcut Print by Sograh Khurasani

In 2009, another Department of Fine Arts in Yogi Vemana University, Kadapa has been established in the Rayalaseema zone which is became second art school in Andhra Pradesh. Painter, Art Writer Dr. K. Mrutyunjaya Rao as a founder faculty took lead role to establish this department. Soon, this department became famous in the state through its extensive activities in Rayalaseema as well as in



Fig.10. National Seminar at Dept of Fine Arts, Kadapa



the state where the art has found none earlier in this region. Soon the department acclaimed fame through the teaching and its activities like National Seminar on Visual Art forms of Medieval India (fig.10) and a National Painting Camp, Artist Residency Programs sponsored by Lalit Kala Akademi, New Delhi(Fig.11). The department has conducted many activities with the help of Department of Culture and Govt of AP and Shilparamam Society.

In 2020, under the bifurcation act of 2014, Dr. YSR Architecture and Fine Arts University at Kadapa is established as a separate university, scooped out from the Jawaharlal Nehru Architecture and Fine Arts University, Hyderabad.

Dr. K.Mrutyunjaya Rao has been deputed by Govt of Andhra Pradesh to the newly established Dr. YSR Architecture and Fine Arts University at Kadapa to take part lead role in establishment under the lead of Prof. D.Vijay Kishore as its first Vice Chancellor who is known as famous Architect and Professor in Architecture from Rayalaseema. Dr. Rao took lead role and actively engaged in establishing the 6 departments such Painting, Sculpture, Animation, Applied Arts, Photography and Art History under the name of College of Art. In 2021, the sudden demise of Prof. Ravi Shankar Patnaik, the sculptor, academician has created a vacuum in the art of Andhra Pradesh especially Fine Arts Department, Andhra University, has lost its visionary and forerunner. Now it seems the art hub of Andhrapradesh has been shifted to Kadapa. Young sculptors K. Appala Naidu, Durga Prasad, K. Sukumar Reddy and Print makers T. Jagadeesh, Barun Mandal, YB. Manohar has joined in the crew of Dr. K.Mrutyunjaya Rao. Meanwhile in the same year 2020, the another Department of Fine Arts has been started in Nagarjuna University at Guntur under the guidance Prof. V.Ramesh and Prof. CRS Patnaik. Alumni of Andhra University Srinivas Padakandla, Sekhar Babu are teaching art there.

As far as concern art galleries, The first art gallery was located at Rajahmundry named as Damerla Rama Rao Memorial Art gallery after the death of Damerla Rama Rao. By the First quarter of 20<sup>th</sup> century Hyderabad gained popularity and achieved the status of Centre of Contemporary Art, in a course of time many private Art Galleries were established. In 1990s in Visakhapatnam several galleries named as “Abhuri Kalakendram(1997)” “Threshold Art Gallery” were established, soon they disappeared in the course of time. The Threshold Gallery has now been shifted to New Delhi. The galleries in Hyderabad are blossoming along with Hyderabad. The establishment of such art galleries highly boosted the interest of art lovers and common spectators and greatly helped in the growth of contemporary art in the area of Telangana and Andhra.

In 2014, due to the division of Andhra Pradesh into two states as Andhra Pradesh and Telangana, the development done at Hyderabad as a focal point since 1940's now gone to Telangana as it was served as capital for the united Andhra Pradesh over 60 years. In result, the residual Andhra Pradesh has none in the field of art after bifurcation, not even a gallery belongs to Government. Especially space for art was little almost as it was a vacuum. Governments came after division has no time and budgetary constrains to support art and Artists. But for last five years the artists and art societies are highly alert and doing their best in promoting Art in Andhra. In the year 2015, some like minded Professional artists and academicians came together with a common ideology, sought to create a dais and then formed as group, titled as “Amaravati Visual Art Society” at Vijayawada as its center under the leadership of the artists and academicians like Dr. K.Mrutyunjaya Rao as its President, Rayana Giridhar Gowd, Teki Mrutyunjaya Rao from Guntur, Srinavas Padakandla, Santosh Pedagadi, Santosh Kumar Pedagadi who are actively working for the development of art in the state. With these latest developments, many senior artists came forward to support all the young and dynamic artists from Andhra Pradesh. But soon, due to the divergent opinions of the members, the Society is passive with little activities for past four years and disappeared on the screen of art of Andhra. Sthapathi Sivanagi Reddy is organizing many cultural activities at the Cultural Center of Vijayawada. Soon it became a prominent promoter for art and culture in Andhra Pradesh. Besides these many, organizations like Artists Association Guild, Telugu World Artists Association (TWAS) and women Art Society are actively engaged in promoting Art. The role of Kalasagar would be unforgettable for his contribution of 64.kalalu website to the art of Andhra.

Many artists like, SD Hari Prasad, Apparao Vasupalli, B.Satyanarayana, Srinivas Padakandla, Krishnamurti Panda, Prabhakar, Bhaskar Rao B, Sadhu Surya Rao T. Kodanda Rao, D. Simhachalam, Pratap Modi, Bandi Durga Prasad, Balaji Ponna, Sudhakar Tadi, Pratap Modi, Appalaraju.S, V. Prasanth, Jagadeesh Tammineni, Kurmanadham, K. Appalanaidu, Govind JSP, Durga Prasad, , G.V. Ramana Murthy, Prabhakar, Syeed, B. Bhakara Rao, M. Venkatesam, S. Surya Rao, Ravi Kiran, Imran Khan, Pulagam Srinivas, Shanmukh T, Rajaramesh, Prasad KVS, RameshT, Swarnalatha Mahapahra, Roja Sanchana, sayya, E.Sunitha, Ramakrishna M, Bobbadi Yernindra, Sandhya Patnaik, Rangula Sandhya, Radha, Pradeep Kumar, Lalitha Tekumalla, Rajasekhar, Ch.Venkatesh, E.Sujatha, Appalachari, Venkatesh Yadav, Sabbana Venkatesh, K.Pooja, P.Sri Kavya, Boby Abraham, Vijay Santosh Kumar, Divya Chinni, BhujangaRao, Shilpa Surana, Uma Vegesina, Ravi Teja, Gollapalli Jayanna,



Manohar Rao YB, Chinarayudu Boya, Yogindra, and many emerging artists are settled in the places like Hyderabad, Baroda, and Mumbai, Delhi, Bangalore, Visakhapatnam, Kadapa with great aspiration and zeal.

## CONCLUSION

The Telugu artists are self-generated and discerning modernity affiliated to their creative pursuits. The senior artists between 20 and 50's sought inspiration from mythology, folk and religion and immediate surrounding with native media of wash technique. The second generations of 60's and 70's adopted images from the child hood memories and rural and contemporary life. The third generation artists from 90's are much inclined to from urban and global realities and more experimental with different kind of media. Artists of Andhra Pradesh are eagerly waiting for off shoot of Lalit Kala Akademi to be installed through which art of Andhra Pradesh can get a fresh breeze and may get abundant opportunities to prove their creative potential.

## REFERENCES

1. M.Rajaji(1978), "Siddha Hasthuda Damerla Rama Rao - Jeevitham Kala rishi", Rajhundry.
2. Telephone Interview with Teki Mrutyunjaya Rao, Artist from Rajahmundry, Student of Rajaji. Madeti.
3. Raman, A.S, "Modern Art in Andhra Pradesh" the Illustrated weekly of India, July 1964.
4. Vinod Kumar(1980), Andhra Scene Lalit Kala Contemporary 3.
5. A.Pydi Raju a monograph by AP Lailt Kala Academy 1978.
6. Telephone Interview with Sri Vijaya Kumar, member of Guntur "Pandavas" in Andhra Pradesh.

## Image Credits:

1. Atmakuru Ramakrishna, Vijayawada.
2. Sunkara Chalapathi Rao, Visakhapatnam.
3. <https://www.gallerythreshold.com/artist/v-ramesh>. ( Prof. V.Ramesh )
4. <https://scroll.in/magazine> (Ravinder G. Reddy)
6. Jagadeesh Thammineni
7. Santosh Pedagadi
8. JSP Govind.
9. Sograh Khurasani.





# FINANCIAL STRESSORS AND TEACHERS' AWARENESS ON FINANCIAL LITERACY AND SURVIVAL PLAN

Anarose M. Blanza

Laguna State Polytechnic University

## ABSTRACT

*The purpose of this study is to determine the relationship between teacher's profile and financial stressors to the level of awareness on financial literacy and survival plan. The research design used in this study was the descriptive method. Purposive sampling was used in this study to identify the educators in Elementary and Secondary public school teachers of Cluster 5, Division of Calamba, City. The statistical treatment of the data was used to compute then analyze the data given by the respondents. This study hypothesized that there is no significant relationship between teachers' profiles and financial stressors regarding awareness of financial literacy and survival plans was accepted.*

## INTRODUCTION

Everyone agrees that teachers play a big part in molding a country's citizens. Apart from academics, they can positively affect many aspects of people's lives. If we want a prosperous nation, we have to ensure that their well-being is taken care of. Teachers in other countries like Switzerland, Germany, and United States are given a high salary and lots of employee benefits. Their government provides enough budget for education, and teachers are one of their priorities.

Here in the Philippines government also provides Filipino teachers. However, is this enough? Then why do some teachers suffering financial stress? Department of Education Secretary Leonor Briones cited the PIDS (Philippine Institute for Developmental Studies) study on households showing that public school teachers are 50% more likely to borrow than other government employees. Most teachers encountered a severe problem in paying for their living with a small salary, most especially amidst COVID19 Pandemic. Most teachers shout for a salary increase, but the big problem is: What if today's government cannot give this appeal.

In 2018, DepEd, in partnership with BDO and BSP, signed a Memorandum of Agreement (MOA). The MOA aims to provide lessons on the responsible handling of personal finances and manage resources through a financial literacy program in compliance with Republic Act 10922 or the Economic and Financial Literacy Act. Taking in action, DepEd uploaded financial literacy videos to DepEd's Online Learning Portals and is now being used for teacher

training nationwide. Like a shred of evidence, the DepEd Division of Calamba used the said materials on their annual Teachers Induction Program and Learning Action Cell. One highlight of the said TIP and LAC sessions is about Financial Literacy and Financial Planning how teachers can wisely use all their finances and not end up crying because of his multiple loans and debts.

In recent years, developed countries have become progressively more concerned about their citizens' financial literacy and financial plan. Financial Literacy means "Knowledge and competence of dealing with money," and Financial Plan talks about a comprehensive picture of current individual finances. Unfortunately, many people have a weak grasp of basic personal finance principles. General attitudes toward spending and saving behavior are troubling as well.

With this, the researcher has believed in the important concept of Financial Literacy and Survival Plan. Also, the reason why the researcher wants to broaden understanding about the issue, the researcher aims to study "Financial Stressors and Teachers; Awareness on Financial Literacy and Survival Plan."

## MATERIALS AND METHODS

Purposive sampling was used in this study to identify the educators in Elementary and Secondary public school teachers of Cluster 5, Division of Calamba, City.

The researcher observed the possible problem within the community, continuously find an answer,

and after the observation, she finally formulated a research problem.

Upon approval by the faculty of Graduate Studies and Applied Research of Laguna State Polytechnic University Sta. Cruz Main Campus, the researcher, first asked the permission of the schools' division superintendent in the Division of Calamba, then the permission of selected elementary and secondary school heads.

In administering the questionnaire, the researcher personally went to each elementary and secondary public school to orient the respondents on the study's objectives to gather complete data needed in the research paperwork. The questionnaire was

validated by the experts and multiplied based on the number of respondents.

The researcher asked the teacher respondents to take time to answer the questions via google forms. Enough time was given to the respondents to answer the questionnaire thoroughly. The responses were tabulated, analyzed, and finally interpreted.

## RESULTS AND DISCUSSIONS

The profile of the teachers was categorized in terms of age, gender, civil status, work position, and years of service.

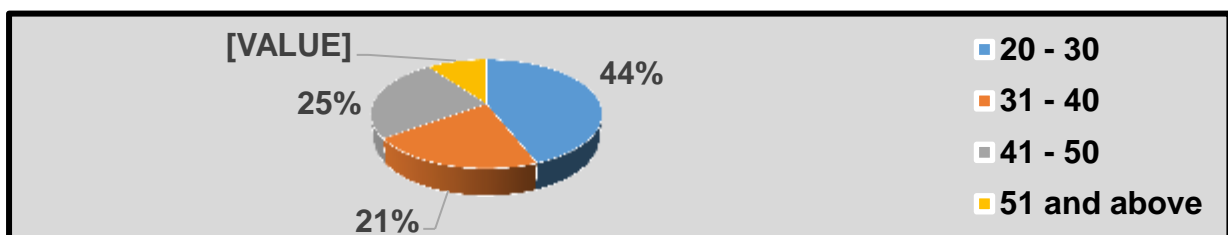


Figure 1. Teachers' Demographic as to Age

Figure 1 shows the age of the teacher-respondents. The majority of the teachers are 20 - 30 years old (44%), while the rest are 31 - 40 years old (21%), 41 - 50 years old (25%), and 51 years old and above

(10%). This means that majority of the teachers are young adults. This is the normal age range of selected teachers.

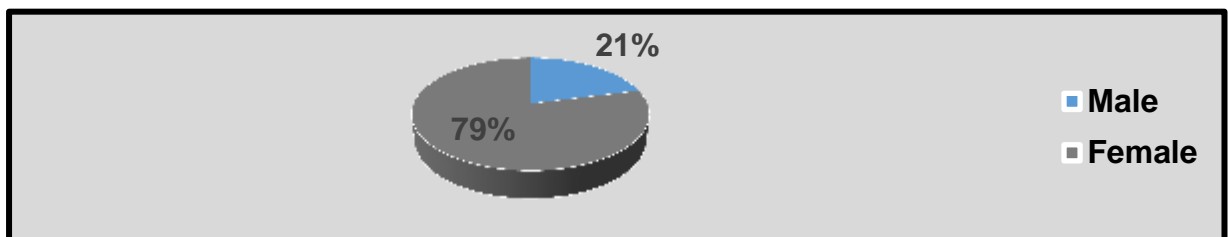


Figure 2. Teachers' Demographic as to Gender

Figure 2 shows the gender of the teacher-respondents. The majority of the teachers are female (79%), while the rest are male (21%). This means

that majority of the teachers are female. This is the normal gender range of selected teachers.

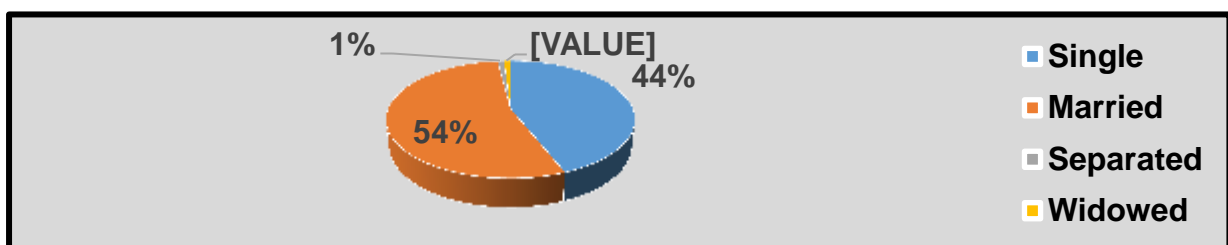
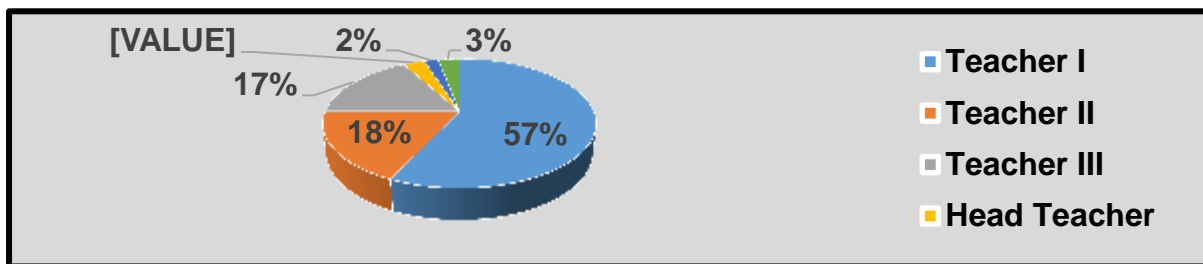


Figure 3. Teachers' Demographic as to Civil Status

Figure 3 shows the civil status of the teacher-respondents. The majority of the teachers are married (54%), while the rest are single (44%), separated (1%), and widowed (1%). This means that majority

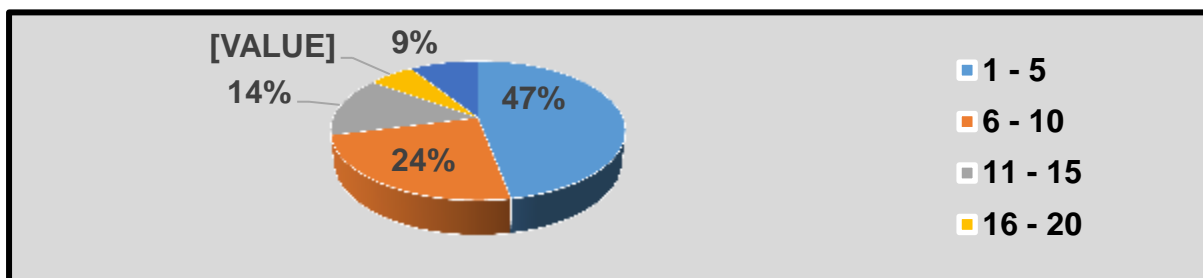
of the teachers are married. This is the normal civil status range of selected teachers.



**Figure 4. Teachers' Demographic as to Work Position**

Figure 4 shows the work position of the teacher-respondents. The majority of the teachers are Teacher I (57%), while the rest are Teacher II (18%), Teacher III (17%), Head Teacher (3%), Master Teacher (2%),

and Principal (3%). This means that majority of the teachers are Teacher I. This is the normal work position range of selected teachers.



**Figure 5. Teachers' Demographic as to Years of Service**

Figure 5 shows the years of service of the teacher-respondents. The majority of the teachers are 1-5 years of service (47%), while the rest are 6-10 years (24%), 11-15 years (14%), 16-20 years (6%), and 21 years and above (9%). This means that majority of the teachers are 1-5 years of service. This is the normal years of service range of selected teachers.

The extent of teachers' financial stressors was described as a personal allowance, rental fee or mortgage, education, loans or debts, and credit cards. To determine the extent of teachers' financial stressors, the data gathered were treated using the weighted mean and standard deviation.

It could be gleaned from the table the extent of teachers' financial stressors in terms of personal allowance.

**Table 1. The extent of Teachers' Financial Stressors in Personal Allowance**

Statements	Mean	S.D.	Verbal Interpretation
1. I feel powerless and experience a loss of control when it comes to budgeting money.	2.91	1.147	Moderate
2. My income as the teacher does not quite cover my living costs.	3.49	1.168	High
3. I find more satisfying to spend than save money for the future.	2.03	1.123	Low
<b>Overall Mean</b>	<b>2.81</b>		<b>Moderate</b>

**Legend:**

Scale	Range	Verbal Description	Verbal Interpretation
5	4.20 - 5.00	Strongly Agree	Very High
4	3.40 - 4.19	Agree	High
3	2.60 - 3.39	Moderately Agree	Moderate
2	1.80 - 2.59	Disagree	Low
1	1.00 - 1.79	Strongly Disagree	Very Low



The table indicates the highest ( $M=3.49$ ,  $SD=1.168$ ) on the statement “Income as the teacher does not quite cover their living costs,” which is verbally interpreted as *High* and the lowest score ( $M=2.03$ ,  $SD=1.123$ ) was on the statement “they find more satisfying to spend than save money for the future.”

The overall mean of  $2.81$  indicates that the teachers believed that personal allowances

*moderately* influence their financial stressors. Although personal thinking allowances monthly is quite challenging while considering limited salary, teachers are pretty good and do not consider personal allowance stressful.

Table 2 shows the Extent of Teachers’ Financial Stressors in Rental Fee or Mortgage

**Table 2. Extent of Teachers’ Financial Stressors in Rental Fee or Mortgage**

Statements	Mean	S.D.	Verbal Interpretation
1. Paying monthly rental fee and mortgage is quite stressful.	3.52	1.059	High
2. With or without interest, paying late (rent, mortgage, debts etc.) is fine.	1.84	1.204	Low
3. Pawn something that I own to pay other bills (mortgage and rental fee)	1.65	0.968	Very Low
<b>Overall Mean</b>	<b>2.34</b>		<b>Low</b>

**Legend:**

Scale	Range	Verbal Description	Verbal Interpretation
5	4.20 – 5.00	Strongly Agree	Very High
4	3.40 – 4.19	Agree	High
3	2.60 – 3.39	Moderately Agree	Moderate
2	1.80 – 2.59	Disagree	Low
1	1.00 – 1.79	Strongly Disagree	Very Low

The table indicates the highest ( $M=3.52$ ,  $SD=1.059$ ) on the statement “Paying monthly rental fee and mortgage is quite stressful,” which is verbally interpreted as *High*, and the lowest score ( $M=1.65$ ,  $SD=0.968$ ) was on the statement “Pawn something that I own to pay other bills (mortgage and rental fee).”

The overall mean of  $2.34$  indicates that the teachers believed that rental fees or mortgage *lowly* influence the extent of their financial stressors. Even

teachers believe and agree that paying monthly rental and mortgage are both stressful, they do not believe that they should pay it to the extent of pawning other items or property. Others believe that solving a problem with another set of the problem should not be considered. In this case, paying a rental fee either mortgage can’t be solved by pawning or paying it late considering its interest.

Table 3 shows the Extent of Teachers’ Financial Stressors in Education

**Table 3. The extent of Teachers’ Financial Stressors in Education**

Statements	Mean	S.D.	Verbal Interpretation
1. It is pretty delicate to borrow/loan money to sustain my master's/doctorate degree.	3.10	1.202	Moderate
2. I Has not been actively saving because of the financial crisis, especially expenses for my education.	2.93	1.233	Moderate
3. Money is there to be spent mostly for education and professional growth.	2.78	1.069	Moderate
<b>Overall Mean</b>	<b>2.94</b>		<b>Moderate</b>



Legend:

Scale	Range	Verbal Description	Verbal Interpretation
5	4.20 – 5.00	Strongly Agree	Very High
4	3.40 – 4.19	Agree	High
3	2.60 – 3.39	Moderately Agree	Moderate
2	1.80 – 2.59	Disagree	Low
1	1.00 – 1.79	Strongly Disagree	Very Low

The table indicates the highest ( $M=3.10$ ,  $SD=1.202$ ) on the statement “It is quite fine to borrow/loan money in order to or sustain teacher’s masters /doctorate.” which is verbally interpreted as *Moderate* and the lowest score ( $M=2.78$ ,  $SD=1.069$ ) was on the statement “Money is there to be spent mostly for education and professional growth.”

The overall mean of  $2.94$  indicates that the teachers believed that education *moderately* influences their financial stressors. This means that somehow teachers agreed how education or

professional growth is important in their profession that they can consider borrowing or loan money to finance their education, with the condition and stable finance. Some teachers also sacrifice savings to finance a master's or doctorate; with this, the after education goal is a promotion which equals the salary increase.

Table 4 shows the Extent of Teachers’ Financial Stressors in Loans or Debts.

**Table 4. The extent of Teachers’ Financial Stressors in Loans or Debts**

Statements	Mean	S.D.	Verbal Interpretation
1. It is pretty delicate to borrow/loan money in order to pay back other debts.	2.47	1.259	Low
2. Take out a personal loan from the financial service provider (public or private).	3.07	1.066	Moderate
3. I tend to live for today and let tomorrow take care of itself.	2.12	1.157	Low
<b>Overall Mean</b>	<b>2.55</b>		<b>Low</b>

Legend:

Scale	Range	Verbal Description	Verbal Interpretation
5	4.20 – 5.00	Strongly Agree	Very High
4	3.40 – 4.19	Agree	High
3	2.60 – 3.39	Moderately Agree	Moderate
2	1.80 – 2.59	Disagree	Low
1	1.00 – 1.79	Strongly Disagree	Very Low

The table indicates the highest ( $M=3.07$ ,  $SD=1.066$ ) on the statement “Take out a personal loan from the financial service provider (public or private).” which is verbally interpreted as *Moderate*, and the lowest score ( $M=2.12$ ,  $SD=1.157$ ) was on the statement “Tend to live for today and let tomorrow take care of itself.”

The overall mean of  $2.55$  indicates teachers believed that loans or debts *lowly* influence the extent of their financial stressors. It is quite a normal

scenario especially in public schools, that teacher has personal loans or debts (public or private provider) sometimes used on emergency days, unexpected expenses, specific goals like buying cars or dream house and more reasons. On the other hand, teachers are responsible enough for managing their finances; they make sure that considering their debts and loans, resources were still available even on rainy days.

Table 5 shows the Extent of Teachers’ Financial Stressors in Credit Cards.





**Table 5. Extent of Teachers' Financial Stressors in Credit Cards**

Statements	Mean	S.D.	Verbal Interpretation
1. Use a credit card with high interest for a cash advance, paying bills or buying food.	1.64	1.020	Very Low
2. Before I buy something using my credit cards, I carefully consider whether I can afford it.	4.41	0.866	Very High
3. I purchased all my expensive items using credit cards.	1.30	0.772	Very Low
<b>Overall Mean</b>	<b>2.45</b>		<b>Low</b>

Legend:

Scale	Range	Verbal Description	Verbal Interpretation
5	4.20 - 5.00	Strongly Agree	Very High
4	3.40 - 4.19	Agree	High
3	2.60 - 3.39	Moderately Agree	Moderate
2	1.80 - 2.59	Disagree	Low
1	1.00 - 1.79	Strongly Disagree	Very Low

The table indicates the highest ( $M=4.41$ ,  $SD=0.866$ ) on the statement "Before buying something using credit cards, they carefully consider whether they can afford it." which is verbally interpreted as *Very High* and the lowest score ( $M=1.30$ ,  $SD=0.772$ ) was on the statement "They purchased all expensive items using credit cards."

The table indicates the highest ( $M=4.41$ ,  $SD=0.866$ ) on the statement "Before buying something using credit cards, they carefully consider whether they can afford it." which is verbally interpreted as *Very High* and the lowest score ( $M=1.30$ ,  $SD=0.772$ ) was on the statement "They purchased all expensive items using credit cards."

The overall mean of 2.45 indicates teachers believed that credit cards *lowly* influence the extent

of their financial stressors. Teachers' responses implicate how responsibly credit cards should be used at all times. As another form of bills and debts, using a credit card irresponsibly may cause financial stress to individuals. Always carefully consider whether you afford items or not, either it is worth buying or just a luxury.

The level of teachers' awareness of financial stressors was described as to Teachers Induction Program (TIP) and Learning Action Cell (LAC). To determine the level of teachers' awareness of financial literacy, the data gathered were treated using the weighted mean and standard deviation.

Table 6 shows the Level of Teachers' Awareness of financial literacy in TIP (Teachers Induction Program)

**Table 6. Level of Teachers' Awareness on financial literacy in TIP (Teachers Induction Program)**

Statements	Mean	S.D.	Verbal Interpretation
1. Fundamental knowledge of finance discussed during TIP Sessions helped me for effective economic decision-making.	4.36	0.732	Extremely Aware
2. During TIP Sessions, I learned about interest rates charged by a bank, borrowing rates and charged by a financial institution.	3.94	0.839	Moderately Aware
3. I learned the meaning of credit ratings by companies and why it is done.	4.09	0.818	Moderately Aware
<b>Overall Mean</b>	<b>4.13</b>		<b>Moderately Aware</b>



Legend:

Scale	Range	Verbal Description	Verbal Interpretation
5	4.20 – 5.00	Strongly Agree	Extremely Aware
4	3.40 – 4.19	Agree	Moderately Aware
3	2.60 – 3.39	Moderately Agree	Somewhat Aware
2	1.80 – 2.59	Disagree	Slightly Aware
1	1.00 – 1.79	Strongly Disagree	Not at all Aware

The table indicates the highest ( $M=4.36$ ,  $SD=0.732$ ) on the statement “Fundamental knowledge of finance discussed during TIP Sessions helped them for effective economic decision making.” which is verbally interpreted as *Extremely Aware*, and the lowest score ( $M=3.94$ ,  $SD=0.839$ ) was on the statement “During TIP Sessions they learned about interest rates charged by a bank, borrowing rates and charged by a financial institution.”

The overall mean of 4.13 indicates the teachers’ awareness on financial literacy was

*moderately aware* in terms of TIP (Teachers Induction Program). This means that conducting seminars like national TIP sessions helps teachers understand some important concepts of financial literacy, which is very important and helpful. Schools worldwide use induction programs to support new teachers in their first years of teaching by contributing to their sense of well-being and professional development.

Table 7 shows the Level of Teachers’ Awareness of financial literacy in LAC (Learning Action Cell)

**Table 7. Level of Teachers’ Awareness on financial literacy in LAC (Learning Action Cell)**

Statements	Mean	S.D.	Verbal Interpretation
1. I learned during LAC Sessions to set aside emergency or rainy day funds that would cover my expenses for three months in case of sickness, job loss, economic downturn, or other emergencies.	3.51	1.068	Moderately Aware
2. I attended LAC sessions and other webinars related to financial literacy and planning.	4.01	1.020	Moderately Aware
3. I use this formula in budgeting my money: SALARY – SAVINGS = EXPENSES.	3.57	1.200	Moderately Aware
<b>Overall Mean</b>	<b>3.70</b>		<b>Moderately Aware</b>

Legend:

Scale	Range	Verbal Description	Verbal Interpretation
5	4.20 – 5.00	Strongly Agree	Extremely Aware
4	3.40 – 4.19	Agree	Moderately Aware
3	2.60 – 3.39	Moderately Agree	Somewhat Aware
2	1.80 – 2.59	Disagree	Slightly Aware
1	1.00 – 1.79	Strongly Disagree	Not at all Aware

The table indicates the highest ( $M=4.01$ ,  $SD=1.020$ ) on the statement “Attended LAC Session and other webinars related to financial literacy and planning.” which is verbally interpreted as *Moderately Aware*. The lowest score ( $M=3.51$ ,

$SD=1.068$ ) was on the statement “Learned during LAC Sessions to set aside emergency or rainy day funds that would cover expenses for three months, in case of sickness, job loss, economic downturn, or other emergencies.”



The overall mean of 3.70 indicates that the teachers' awareness of financial literacy was moderately aware of LAC (Learning Action Cells). Follow up concepts for other seminars conducted by DepEd and possible solutions to the problems encountered by schools and teachers are discussed during LAC sessions, some topic was about Financial Literacy. Teachers learned the concept of saving to be prepared on rainy days and the best formula used

in saving money on LAC sessions. Some other seminars/webinars attended by teachers are about the importance of financial literacy and planning.

The level of teachers' awareness of survival plans was described as savings, investment, and insurance. To determine teachers' awareness of the survival plan, the data gathered were treated using the weighted mean and standard deviation.

Table 8 shows the Level of Teachers' Awareness on Survival Plan in terms of Savings.

**Table 8. Level of Teachers' Awareness on Survival Plan in Savings**

Statements	Mean	S.D.	Verbal Interpretation
1. I have an adequate emergency fund.	3.19	1.012	Somewhat Aware
2. I feel that I am very good at saving money.	3.06	1.023	Somewhat Aware
3. I regularly set aside money each month for savings and future needs.	3.24	1.111	Somewhat Aware
<b>Overall Mean</b>	<b>3.16</b>		<b>Somewhat Aware</b>

Legend:

Scale	Range	Verbal Description	Verbal Interpretation
5	4.20 - 5.00	Strongly Agree	Extremely Aware
4	3.40 - 4.19	Agree	Moderately Aware
3	2.60 - 3.39	Moderately Agree	Somewhat Aware
2	1.80 - 2.59	Disagree	Slightly Aware
1	1.00 - 1.79	Strongly Disagree	Not at all Aware

The table indicates the highest ( $M=3.24$ ,  $SD=1.111$ ) on the statement "They regularly set aside money each month for savings and future needs." which is verbally interpreted as *Somewhat Aware*, and the lowest score ( $M=3.06$ ,  $SD=1.023$ ) was on the statement "Feel that they are outstanding in saving money."

The overall mean of 3.16 indicates the teachers' awareness of the survival plan was *somewhat aware* in terms of savings. Teachers really

face the reality that their salary is not as high as another profession, but the expenses were almost or sometimes greater, it is too difficult for them to save more with their situation and obligations. Nevertheless, it does not mean that saving is not their priority; they still do their best to save for the future.

Table 9 shows the Level of Teachers' Awareness on Survival Plan in terms of Investments.

**Table 9. Level of Teachers' Awareness on Survival Plan in Investments**

Statements	Mean	S.D.	Verbal Interpretation
1. I would go for investing even if there were risks involved.	3.17	1.083	Somewhat Aware
2. Maintaining appropriate liquid assets is a must for every individual.	3.56	0.880	Moderately Aware
3. To reach my financial goal, I prefer an investment that is safe and grows slowly but steadily, even if it means lower growth overall.	3.68	0.973	Moderately Aware
<b>Overall Mean</b>	<b>3.47</b>		<b>Moderately Aware</b>



Legend:

Scale	Range	Verbal Description	Verbal Interpretation
5	4.20 – 5.00	Strongly Agree	Extremely Aware
4	3.40 – 4.19	Agree	Moderately Aware
3	2.60 – 3.39	Moderately Agree	Somewhat Aware
2	1.80 – 2.59	Disagree	Slightly Aware
1	1.00 – 1.79	Strongly Disagree	Not at all Aware

The table indicates the highest ( $M=3.68$ ,  $SD=0.973$ ) on the statement “To reach their financial goal they prefer an investment which is safe and grows slowly but steadily, even if it means lower growth overall.” which is verbally interpreted as *Moderately Aware* and the lowest score ( $M=3.17$ ,  $SD=1.083$ ) was on the statement “Would go for investing even if there were risk involve.”

The overall mean of 3.47 indicates the teachers’ awareness of the survival plan was *moderately aware* in terms of investments. This means that teachers know how investments can help their finances and plans. Teachers are risk-takers, willing to start from basic and slowly grow.

Table 10 shows the Level of Teachers’ Awareness on Survival Plan in terms of Insurance.

**Table 10. Level of Teachers’ Awareness on Survival Plan in Insurance**

Statements	Mean	S.D.	Verbal Interpretation
1. Life, Health and Property must be insured.	4.35	0.796	Extremely Aware
2. I have adequate insurance protection for my life, health and my possession.	3.80	0.932	Moderately Aware
3. I can distinguish the different types of insurance policies offered in the market.	3.40	1.044	Moderately Aware
<b>Overall Mean</b>	<b>3.85</b>		<b>Moderately Aware</b>

Legend:

Scale	Range	Verbal Description	Verbal Interpretation
5	4.20 – 5.00	Strongly Agree	Extremely Aware
4	3.40 – 4.19	Agree	Moderately Aware
3	2.60 – 3.39	Moderately Agree	Somewhat Aware
2	1.80 – 2.59	Disagree	Slightly Aware
1	1.00 – 1.79	Strongly Disagree	Not at all Aware

The table indicates the highest ( $M=4.35$ ,  $SD=0.796$ ) on the statement “Life, Health and Property must be insured.” which is verbally interpreted as *Extremely Aware* and the lowest score ( $M=3.40$ ,  $SD=1.044$ ) was on the statement “Can distinguish the different types of insurance policies offered in the market.”

The overall mean of 3.85 indicates the teachers’ awareness of the survival plan was *moderately aware* in terms of the insurance. In today’s era, incidents and problems mostly happen at an unexpected time; being insured in all aspects was very important. Most teachers join different

insurance companies that gave them security in times of need and make sure of the readiness in all aspects.

In determining the relationship of Respondents Profile and Teachers’ Financial Stressors to Financial literacy and Survival Plan, the data gathered by the researcher were computed electronically using the Minitab and treated statistically using Pearson Correlation.

The table below shows the Pearson-r values and p-values of the following variables. The researcher used the p-value in determining the result of the data collected. A p-value was higher than 0.05 means that the null hypothesis is accepted, while a



value lower than the alpha level means that the null hypothesis is rejected.

Table 11 shows the relationship between teachers' profiles and financial literacy in terms of

TIP (Teachers Induction Program) and LAC (Learning Action Cell).

**Table 11. Test of Relationship between Teachers' Profile and Financial Literacy**

Teachers' Profile	Financial Literacy	Pearson Correlation Value	P-value	Interpretation
Age	TIP	0.080	0.430	Not Significant
	LAC	0.177	0.078	
Gender	TIP	-0.108	0.283	Not Significant
	LAC	0.009	0.929	
Civil Status	TIP	0.088	0.382	Not Significant
	LAC	0.085	0.401	
Work Position	TIP	0.181	0.071	Not Significant
	LAC	0.085	0.401	
Years of Service	TIP	0.034	0.739	Not Significant
	LAC	0.078	0.439	

**Legend:**

P-value	Interpretation
P<0.05	Significant
P>0.05	Not Significant

As reflected in the table, the teachers' age and its relationship to TIP and LAC obtained Pearson-r values of 0.080 and 0.177 with p-values of 0.430 and 0.078. The teachers' profile in terms of gender and its relationship to Financial Literacy in terms of TIP and LAC obtained Pearson-r values of -0.108 and 0.009 with p-values of 0.283 and 0.929. Moreover, the teachers' profile in terms of civil status and its relationship to TIP and LAC obtained Pearson-r values of 0.088 and 0.085 with p-values of 0.382 and 0.401. The teachers' profile in terms of work position and its relationship to Financial Literacy in terms of TIP and LAC obtained Pearson-r values of 0.181 and 0.085 with p-values of 0.071 and 0.401, and lastly, teachers' profile in terms of years of service and its relationship to Financial Literacy in terms of TIP and LAC obtained a Pearson-r values of 0.034, and 0.078 with p-values of 0.739 and 0.439. The above result are verbally interpreted as *Not Significant*. Therefore, there is no significant relationship between Teachers' Profile and Teachers' Financial Literacy.

This implies that teachers' profiles do not have a relationship to the financial literacy of teachers. Regardless of their profile, teachers can still be financially literate; this concept is merely based on their willingness and intention to grow personally and professionally, specifically in their finances.

Table 12 shows the relationship of teachers' profile and survival plan in terms of savings, investments, and insurances.

As reflected in the table, the teachers' age and its relationship to savings, investment, and insurance obtained Pearson-r values of 0.122, -0.053, and 0.078 with p-values of 0.228, 0.600, and 0.441. Their gender and relationship to savings, investment, and insurance obtained Pearson-r values of -0.006, -0.092, and 0.028 with p-values of 0.950, 0.363, and 0.782. Moreover, teachers' profile in terms of civil status and its relationship to savings, investment, and insurance obtained Pearson-r values of 0.117, -0.017, and -0.028 with p-values of 0.245, 0.865, and 0.780; teachers' profile in terms of work position and its relationship to savings, investment and insurance obtained Pearson-r values of 0.264, 0.197 and 0.201 with p-values of 0.008, 0.037 and 0.045; and lastly teachers' profile in terms of years of service and its relationship to savings, investment and insurance obtained Pearson-r values of 0.146, 0.019 and 0.089 with p-values of 0.147, 0.850 and 0.376. The above result is verbally interpreted as *Not Significant*. Therefore, there is no significant relationship between Teachers' Profile and Survival plans.





**Table 12. Test of Relationship between Teachers' Profile and Survival Plan**

Teachers' Profile	Survival Plan	Pearson Correlation Value	P-value	Interpretation
Age	Savings	0.122	0.228	Not Significant
	Investment	-0.053	0.600	
	Insurance	0.078	0.441	
Gender	Savings	-0.006	0.950	Not Significant
	Investment	-0.092	0.363	
	Insurance	-0.028	0.782	
Civil Status	Savings	0.117	0.245	Not Significant
	Investment	-0.017	0.865	
	Insurance	-0.028	0.780	
Work Position	Savings	0.264	0.008	Significant
	Investment	0.197	0.037	
	Insurance	0.201	0.045	
Years of Service	Savings	0.146	0.147	Not Significant
	Investment	0.019	0.850	
	Insurance	0.089	0.376	

**Legend:**

P-value	Interpretation
P<0.05	Significant
P>0.05	Not Significant

This implies that regardless of teachers' profile, they understand the importance of being financially ready in all aspects of savings, investments, and insurances. The only thing that

matters is understanding and applying the concept of financial literacy so that financial planning follows that accomplish individual survival plan.

**Table 13. Test of Relationship between Teachers' Financial Stress and Financial Literacy**

	Financial Literacy	Pearson Correlation Value	P-value	Interpretation
Teachers' Financial Stressors	TIP	-0.032	0.751	Not Significant
	LAC	0.008	0.938	Not Significant

**Legend:**

P-value	Interpretation
P<0.05	Significant
P>0.05	Not Significant

Table 13 shows the relationship between teachers' financial stressors and financial literacy. As reflected in the table, the Teachers' Financial stressors and their relationship to Financial Literacy in terms of TIP and LAC obtained Pearson-r values of *-0.032* and *0.008* with p-values of *0.751* and *0.938*, which is verbally interpreted as *Not Significant*. Therefore, there is no significant relationship

between Teachers' Financial Stressors and Teachers' Financial Literacy.

It means that teachers can merely define and understand financial stressors without financial literacy sessions via TIP or LAC. They can able to handle those financial stressors and solve problems. It is believed that human being learns a lot on their experiences on the part of teachers, most of them



encounter budgeting, rental fee, mortgage, education, loans or debts, and even credit cards but why they did not take it as stressors, simply because it becomes their life routine that teaches them how to handle it smoothly and avoid problems about finances. On the other hand, sessions about finances were still important and can help teachers deeply understand the concept of financial literacy and planning.

Table 14 shows the relationship between teachers' financial stressors and survival plans. As

reflected in the table, the teachers' financial stressors and their relationship to survival plans in terms of savings, investments, and insurance obtained Pearson-r values of  $-0.019$ ,  $0.033$ , and  $0.015$  with p-values of  $0.854$ ,  $0.744$ , and  $0.882$ , which is verbally interpreted as *Not Significant*. Therefore, there is no significant relationship between Teachers' Financial Stressors and Teachers' Survival plans.

**Table 14. Test of Relationship between Teachers' Financial Stressors and Survival Plan**

	Survival Plan	Pearson Correlation Value	P-value	Interpretation
Teachers' Financial Stressors	Savings	-0.019	0.854	Not Significant
	Investment	0.033	0.744	Not Significant
	Insurance	0.015	0.882	Not Significant

**Legend:**

P-value	Interpretation
P<0.05	Significant
P>0.05	Not Significant

This implies that teachers who are honorable by profession can handle financial stresses and see survival plans in different perceptions, even in different ways, still understand the two concepts. Being wise in finances is a good thing, especially for teachers, knowing that they are surrounded by people who see them as role models. As cited by Deng et al. (2013), Cole shows that people with low levels of financial literacy often fail to plan for retirement, borrow at high interest rates, and are less likely to participate in the financial system. Being aware and able to handle financial crises does not mean a different understanding of survival plans and vice versa. Financial stressors and survival plans in deep have differences that may be why teachers do not see any relation.

**CONCLUSIONS**

Based on the findings of the study the following conclusions were hereby given:

The teachers' profile as to financial literacy showed a *"no significant relationship"*, as to teachers' profile as to survival plan showed a *"no significant relationship"*, while financial stressors as to financial literacy showed a *"no significant relationship"*, and financial stressors as to survival plan showed a *"no significant relationship"*.

The hypothesis stating that there is no significant relationship between teachers' profiles and financial stressors regarding awareness of financial literacy and survival plans were accepted.

**ACKNOWLEDGMENTS**

Deepest gratitude and appreciation are given to ALMIGHTY GOD, for his continuous pouring of countless blessings, for the courage and learned lessons the researcher had gained through the last page of this research study.

The following persons who helped contributed and gave their time and support in the accomplishment of this research paper:

Dr. Mario R. Briones, the President of Laguna State Polytechnic University, for his leadership and utmost concern for the future of all the students;

Dr. Florhaida V. Pamatmat, present Dean of the College of Teacher Education, for her utmost considerations and responses;

Dr. Ray Samuel G. Grecalda for his highly valued guidance, understanding, and never-ending support until the researcher finished the study;

Dr. Marilyn P. Juacalla, the researcher's statistician, for her patience extended in reviewing the manuscript that sourced constructive criticisms that led to the study's improvement.

Dr. August V. Tuiza, researcher's subject specialist, for his unselfishness in sharing her expertise;



Dr. Evelyn L. Balaoro, the researcher's technical expert, for improving and adding substance to the content to become more informative;

Dr. Nimfa G. Dimaculangan, who patiently scrutinized the grammar used in this study and humbly shared her expertise;

Dr. Harold V. Orignes, the researcher's external statistician, for sharing his expertise in checking and computing the gathered data;

Dr. Susan DL. Oribiana, Schools Division Superintended and School Heads for allowing the researcher to conduct a research study at Elementary and Secondary Schools of Cluster V, Division of Calamba City.; the selected Teachers of Cluster V for the success of this research as they served as respondents of the study.;

MAEd Major in Social Science classmates and friends, for the valuable support and laughter during her stay at Laguna State Polytechnic University, Santa Cruz Campus;

Castorian Family, most especially Grade 9 Department, for encouraging, giving the strength to continue, moral support, and being friends to be count during a difficult time;

For their love, sacrifices, patience, and guidance, her beloved parents, Mr. Anastacio M. Blanza, Mr. Rolando O. Taguilaso (+), and Mrs. Jeanielyn M. Taguilaso beginning of her studies. Her siblings, Angela, Alyssa, Bea, and Steve who have been a great source of motivation and inspiration;

Her partner, Christopher M. Taguilaso, for his wholehearted support to the researcher from the title proposal up to the final defense.

## REFERENCES

1. Addin, M., Nayebzadeh S., & Taft, M. (2013). *Financial Strategies and Investigating the Relationship among Financial Literacy, Financial Well-Being, and Financial Worry*. City: *European Online Journal of Natural and Social Science*.
2. Agarwalla, S. (2010). *Financial Counseling, Financial Literacy, and household Decision Making*. Pension Research Council. Working Paper, 2010-34, Retrieved from: [https://papers.ssrn.com/sol3/papers.cfm?abstract\\_id=1628975](https://papers.ssrn.com/sol3/papers.cfm?abstract_id=1628975)
3. Alico, I. E. (2013). *Resident's Awareness on the Job Performance of Elected Barangay Officials at Purok II of Barangay Bagong Pook in Pila, Laguna*. Laguna State Polytechnic University Sta. Cruz Campus.
4. Ali, S., (2013). *Financial literacy in Malaysia: Issues and Status Update*. Malaysia Publication
5. Atkinson, A. (2012). *Young People, Money Management, Borrowing, and Saving: A report to the Banking Code Standards Board*. Retrieved from: [http://www.pfrc.bris.ac.uk/Reports/BCSB\\_young\\_people](http://www.pfrc.bris.ac.uk/Reports/BCSB_young_people)
6. Ausubel (2011). *Parents Education and Real Mothers Age as Predictors of Students Achievement in Mathematics I Some Secondary Schools*. Retrieved from [www.academicleadership.org](http://www.academicleadership.org)
7. Bates, B. (2016). *Learning Theories Simplified*. London, England. Sage Publication.
8. Beckmann, E., (2013). *Financial Literacy and Household Savings in Romania*. Numeracy, Vol. 6, Issue 2, Article 9. Bhushan, P. and Yajulu, M., (2013). "Financial Literacy and Its Determinants," *International Journal of Engineering, Business and Enterprise Applications*, Vol. 4, No. 2, pp. 155-160.
9. Blanza, A. M. (2016). *Small Town Lottery on the Morality and Budget Handling of Bettors in Brgy. San Jose Luisiana, Laguna*. Laguna State Polytechnic University Sta. Cruz Campus.
10. Boudersa, N. (2016). *The Importance of Teachers' Training Programs and Professional Development in the Algerian Educational Context: Toward Informed and Effective Teaching Practices*. Retrieved from: <https://www.researchgate.net/publication/309430087>
11. Brahmer, L. H. (2010). *Therapeutic Psychology*. U.S.A: *Apprentice Hall. Inc*.
12. Bruhn, M. and Zia, B., (2011). *Stimulating Managerial Capital in Emerging Markets: The Impact of Business and Financial Literacy for Young Entrepreneurs*. Retrieved From <http://econ.worldbank.org/external/default/main>
13. Business World (2019). *Boosting Filipinos' Financial Literacy, One Program at a Time*. Retrieved from <https://www.bworldonline.com/boosting-filipinos-financial-literacy-one-program-at-a-time/>
14. Calabit, A. X. (2014). *Performance of Sining Katutubo Dance Assembly (SIKADA): An Analysis*. Laguna State Polytechnic University Sta. Cruz Campus.
15. Calderon, J. F., Ed. D. (2011). *Methods of Research and Thesis*. Pinescor Union Mandaluyong, City: *National Book Store*.
16. Cardwell J. (2019). *Does Money Management matter if You're Poor?*. Retrieved from <http://www.moneymanagement.org/Community/Blogs/Blogging-for-Change/2014/January/Does-money-management-matter-if-you-are-poor.aspx>
17. Chand, S. (2020). *Training: Meaning, Definitions, and Types of Training*. Retrieved from: <http://www.yourarticlelibrary.com/human-resource-development/training-meaning-definition-and-types-of-training/32374>



18. Christelis, D., Tullio J. and Mario P., (2010). "Cognitive Abilities and Portfolio Choice." *European Economic Review* 54, pp. 18-38
19. Collins, J.M., (2012) *Financial Advice: A Substitute for Financial Literacy?* Working Paper Series. Retrieved from: <http://ssrn.com/abstract=2046227>
20. *Consumers Purchasing Power* (2018). Retrieved from <https://learn.saylor.org/mod/page/view.php?id=8865>
21. Copur, Z., (2014). *The Relationship Between Financial Issues and Marital Relationship*. Retrieved from: <https://www.researchgate.net/publication/289536989>
22. Cude, B.J., (2010). *Financial Literacy, the Journal of Consumer Affairs*, 44(2).
23. De Bassa S. C., (2013). *Financial Literacy and Financial Behavior Among Young Adults: Evidence and Implications*. *Numeracy: Vol. 6: Issue. 2, Article 5*.
24. Delafrooz, H. and Laily P., (2011). *Determinants of Financial Wellness among Malaysia Workers*. *African Journal of Business Management* 5.
25. Deng, H., and Chi, I (2013). *Influence of Financial Literacy of Teachers on Financial Education Teaching in Elementary School*. Retrieved from: <http://www.ijeeee.org/Papers/195-K10068.pdf>
26. Eisma, K. (2019). *Factors Influencing Teachers' Level of Awareness on Child Protection Policy and Child Abuse: Basis for Action Plan*. Laguna State Polytechnic University Los Banos Campus.
27. Ernas, J. V. (2010). *Children Beggars in Sta.Cruz their Self Esteem and Educational Internet*. Laguna State Polytechnic University Sta. Cruz Campus.
28. Essien, E., Oko E. & Obot I., (2016). *The Influence of In-Service Training, Seminars and Workshops Attendance by Social Studies Teachers on Academic Performance of Students in Junior Secondary Schools Incross River State, Nigeria*. Retrieved from: <https://files.eric.ed.gov/fulltext/EJ1112947.pdf>
29. Fatoki, O., (2014). *The Financial Literacy of Non-Business University Students in South Africa: International Journal of Education and Science*. (2): 261-267.
30. Felipe, R., (2013). *The Importance of Seminars and Trainings in Improving Teachers Performance*. Retrieved from: <http://www.teachersessay.com/the-importance-of-seminars-and-trainings-in-improving-teachers-performance/>
31. Fernandes, D., (2014). *Financial Literacy, Financial Education and Downstream Financial Behaviors*. Working Paper Series. Retrieved from: <http://ssrn.com/abstract=2333898>
32. *Financial Literacy* (2019). Retrieved from <https://www.financialeducatorsCouncil.org/what-is-financial-literacy/>
33. *Financial Management* (2019). Retrieved from: [Investopedia.com](http://Investopedia.com)
34. *Financial Pressure* (2019). Retrieved from <https://www.lifeline.org.au/static/uploads/files/what-is-financial-pressure-wf1bbswbwkqj.pdf>
35. Ford, M. W., and Kent, D.W., (2010). *Gender Differences in Student Financial Market. Attitudes and Awareness: An Exploratory Study*. Copyright C \_ Heldref Publications.
36. Hawk, W. (2011). *Household Spending by Single Persons and Married Couples in their Twenties: A Comparison*. Retrieved from: <https://www.bls.gov/cex/anthology11/csxanth6.pdf>
37. *Comparison*. Retrieved from: <https://www.bls.gov/cex/anthology11/csxanth6.pdf>
38. Holzmann, R., (2010). *Bringing Financial Literacy and Education to Low and Middle Income Countries: The Need to Review, Adjust and Extend Current Wisdom*. World Bank, IZA and CES Revised Draft.
39. Kagan, J., (2020). *Insurance*. Retrieved from: <https://www.investopedia.com/terms/i/insurance.asp>
40. Kamakia, M., (2017). *Financial Literacy and Financial Wellbeing of Public Sector Employees: A Critical Literature Review*. Retrieved from: <https://www.researchgate.net/publication/318056037>
41. Kharchenko and Olga. (2011). *Financial Literacy in Ukraine: Determinants and Implications for Saving Behavior*.
42. Kloosterman. (2012). *The Importance of Continuing Professional Development*. Retrieved from: <https://continuingprofessionaldevelopment.org/why-is-cpd-important/>
43. *Law Insider* (2020). *Years of Service*. Retrieved from: <https://www.lawinsider.com/dictionary/years-of-service>
44. Llego, M. (2019). *Teachers Induction Program and Education*. Retrieved from: <https://www.teacherph.com/teacher-induction-program/>
45. Lusardi, A. and Mitchell, O.S., (2011). *Financial Literacy and Planning: Implications for Retirement Wellbeing*. Working Paper 17078, National Bureau of Economics Research. Retrieved from: <http://www.nber.org/papers/w1707>
46. MacDonald, M. (2010). *Savings Behavior and Financial Problems Among College Students: The Role of Financial Literacy- Cross-Cultural Communication*. Vol. 6. No. 3, 103-110.
47. *Merriam Webster Dictionary* (2015), *Age*. Retrieved from <http://www.merriam-webster.com/dictionary/age>
48. Michaels, Meredith W. (2010). *Gender*. Retrieved from <http://www.answer.com/gender>
49. Montalbo I. (2017). *Financial Literacy of Professional and Pre-service Teachers in the Philippines*. Retrieved from: [https://www.researchgate.net/publication/322375634\\_Financial\\_Literacy\\_of\\_Professional\\_and\\_Pre-Service\\_Teachers\\_in\\_the\\_Philippines](https://www.researchgate.net/publication/322375634_Financial_Literacy_of_Professional_and_Pre-Service_Teachers_in_the_Philippines)
50. Natalie G., Cameron N., and Chrissann P., (2010). *A Framework for Assessing Financial*



*Literacy and Superannuation Investment Choice Decisions.*

51. Owusu, E. (2015). *Assessing the Level of Financial Literacy among Teachers: A Case Study of Sekyere East District of Ashanti Region of Ghana*. Retrieved from:
52. <http://ir.knust.edu.gh/bitstream/123456789/8611/1/OWUSU%20ERIC%20NKRUMAH.pdf>
53. *Queens University of Charlotte (2021). The Importance of Professional Development for educators.* Retrieved from: <https://online.queens.edu/resources/article/professional-development-for-educators/>
54. Ramakrishnan, R. (2012). *Financial Literacy and Financial Inclusion, 29th Skoch Summit. Mumbai India.*
55. Rule, R. (2010). *Connected in Separation: A Study on Family Dynamics and Long- Distance Interpersonal Communication Relationships of Manila Based OFW Families.* Laguna State Polytechnic University Sta. Cruz Campus.
56. Russell, K. and Stramoski, S., (2011). *Financial management practices and attitudes of dental hygienists: descriptive study.* American Dental Hygienists Association.
58. Sabri, Mohamad F. F., (2011). *Pathways to Financial Success: Determinants of Financial Literacy and Financial*
59. *Well-being among Young Adults.* Doctoral Dissertation, Iowa State University.
60. *Science Daily (2019).* Retrieved from <https://www.sciencedaily.com/releases/2015/06/150601075818.htm>
61. Stotsky, J. (2010). *Budgeting with Women in Mind.* Retrieved from: <https://www.imf.org/external/pubs/ft/fandd/2007/06/stotsky.htm>
62. Surendar, G. (2018). *Financial Literacy and Financial Planning among Teachers of Higher Education: A Study of Critical Factors of Select Variables.* Retrieved from: <https://acadpubl.eu/jsi/2018-118-18/articles/18b/54.pdf>
63. *Teachers' Fret: 'Lending na Walang Ending' (2019).* Retrieved from <https://www.philstar.com/lifestyle/health-and-family/2019/07/17/1935215/teachers-fret-lending-na-walang-ending>
64. *Theory of Problem Solving.* Retrieved from: [https://www.researchgate.net/publication/277651623\\_Theory\\_of\\_Problem\\_Solving](https://www.researchgate.net/publication/277651623_Theory_of_Problem_Solving)
65. Travis, (1969). *Labeling Theory.* Retrieved from [http://sociology.about.com/od/L\\_Index/g/Labeling-Theory.htm](http://sociology.about.com/od/L_Index/g/Labeling-Theory.htm)
66. Vedder, C. B. (2011) *Middle Age Personal Profile.* Springfield: Brokcole Press.
67. *Years of Service (2020).* Investopedia. Retrieved from <https://www.insuranceopedia.com/definition/4913/years-of-service>





# SIMILARITIES BETWEEN EMPEROR CHANDRAGUPTA II (VIKRAMADITYA) AND EMPEROR JALALUDDIN MUHAMMAD AKBAR

**Rajesh Sonkusare**

Assistant Professor (History), Mhr. Sharad Pawar College of Art, Commerce and Science  
R.T.M.Nagpur University, Nagpur

Article DOI: <https://doi.org/10.36713/epra7289>  
DOI No: 10.36713/epra7289

## ABSTRACT

*In the history of a great country like India, there have been many rulers since ancient times who ruled different regions of India at different times. But few of these rulers are called great rulers. Maurya ruler Chandragupta Maurya and Emperor Ashoka, Gupta ruler Chandragupta II (Vikramaditya), Vardhana ruler Harshavardhana, Kushan emperor Kanishka, Satavahana ruler Gautamiputra Satkarni, Chalukya ruler Pulakeshi II, Chola rulers Rajaraja Chola and Rajendra Chola, Rashtrakuta ruler Amoghvarsh, Pratihara ruler Mihira bhoja, Mughal emperor Jalaluddin Muhammad Akbar are named.*

*Among these great rulers of India were two rulers whose lives and work were very similar. The rulers were the Gupta emperor Chandragupta II (Vikramaditya) and the Mughal emperor Jalaluddin Muhammad Akbar.*

*The similarity between Chandragupta II (Vikramaditya) and Jalaluddin Mohammad Akbar is that the grandfather of both the rulers was the real founder of their kingdom. Both the rulers came to power through struggle (war). Both the rulers were tolerant rulers. The empire of the two rulers extended from present day Pakistan in the north to the mouth of the river Narmada in the south and from the mouth of the river Ganga in the east to the mouth of the river Indus in the west. Art, architecture, etc. developed during the reign of both the rulers. Due to the excellent administrative system of both the rulers, their empire remained stable for many generations to come. The main similarity between the two rulers is that in the history of India, only this two rulers have the Navratna in their court.*

**KEYWORDS :** Chandragupta II (Vikramaditya), Jalaluddin Muhammad Akbar, Navaratna, Babar, Chandragupta I, Samudragupta, Humayun, Hemu (Hemchandra), Rudrasen III.

## INTRODUCTION

India had many small and large states since ancient times. The ruler who rules over those kingdoms is usually called a king. In ancient times, the king was called by different titles in different parts of India. Such as Virat in North India, Bhoj in South India, Samrat in East India, Swarat in West India and Raja in Central India. Later, in medieval times, kings were referred to as Sultans and Badshaha. The Maratha kings were referred to as Chhatrapati. Thus many rulers (kings) came to different parts of India at different times.

Some of the rulers of India have become famous as great rulers

That is

Maurya ruler Chandragupta Maurya and Emperor Ashoka,

Gupta ruler Chandragupta II (Vikramaditya),

Vardhana ruler Harshavardhana,

Kushan emperor Kanishka,

Satavahana ruler Gautamiputra Satkarni,  
Chalukya ruler Pulakeshi II,  
Chola rulers Rajaraja Chola and Rajendra Chola.  
Rashtrakuta ruler Amoghvarsh,  
Pratihara ruler Mihira bhoja,  
Mughal emperor Jalaluddin Muhammad Akbar,  
Maratha ruler Chhatrapati Shivaji and Chhatrapati Sambhaji ..... etc

During his reign, these great rulers performed many public works, protected the people of the state from enemies and during their time, art, literature, architecture .... Etc. developed.

But two of these great rulers of India had a great deal in common in their lives and work. The rulers were the Gupta emperor Chandragupta II (Vikramaditya) and the Mughal emperor Jalaluddin Muhammad Akbar.

### Gupta Emperor Chandragupta II (Vikramaditya) (380 AD to 415 AD) :

Chandragupta II was the son of the Gupta emperor Samudragupta and the grandson of Chandragupta I. Emperor Chandragupta II was the most powerful emperor of the Gupta Empire in the Indian Subcontinent. During his reign of 380 AD to 415 AD, the Gupta Empire flourished in every field.

### Mughal Emperor Jalaluddin Muhammad Akbar (1556 AD to 1605 AD) :

Emperor Jalaluddin Muhammad Akbar was the son of Mughal emperor Humayun and grandson of Babur. Jalaluddin Muhammad Akbar was the most powerful emperor of the Mughal Empire in the Indian subcontinent. During his reign of 1556 AD to 1605 AD, the Mughal Empire developed.

### Similarities between the Gupta Emperor Chandragupta II (Vikramaditya) and the Mughal Emperor Jalaluddin Muhammad Akbar :

The Gupta Emperor Chandragupta II (Vikramaditya) and the Mughal Emperor Jalaluddin Muhammad Akbar both ruled India at different times. But there are striking similarities between the two. They are as follows :

1. The real founder of the Gupta Empire in India of the Gupta Emperor Chandragupta II (Vikramaditya) was his grandfather Chandragupta I, while the real founder of the Mughal Empire in India of the Mughal Emperor Jalaluddin Mohammad Akbar was his grandfather Babur.
2. Chandragupta II (Vikramaditya) became the emperor of the Gupta Empire by defeating the Shaka king Rudrasen III, while Jalaluddin Muhammad Akbar became the emperor of the Mughal Empire by defeating Adilshah Suri's general Hemu (Hemchandra)
3. The empire of both the Gupta emperor Chandragupta II (Vikramaditya) and the Mughal emperor Jalaluddin Muhammad Akbar stretched from the mouth of the river Ganga in the east to the mouth of the river Indus in the west, present day Pakistan and Kashmir in the north to the valleys of the river Narmada in the South.



Empire of Chandragupta II (Vikramaditya) 400 A.D.



Jalaluddin Muhammad Akbar Empire 1600 A.D.

4. The Gupta emperor Chandragupta II (Vikramaditya) and the Mughal emperor Jalaluddin Muhammad Akbar were both known as tolerant rulers. The Gupta emperor Chandragupta II (Vikramaditya) was a Vaishnava of Hinduism. Yet he pursued a tolerant policy towards Shaivism,



Buddhism and Jainism. The Mughal emperor Jalaluddin Muhammad Akbar was a Sunni Muslim. However, he adopted a tolerant policy towards Shia Muslims, Hinduism, Sikhism, Buddhism, etc.

5. The Gupta Emperor Chandragupta II (Vikramaditya) and the Mughal Emperor Jalaluddin Mohammad Akbar were the only two rulers who were able to rule for many generations to come.

6. The Gupta Emperor Chandragupta II (Vikramaditya) and the Mughal Emperor Jalaluddin Mohammad Akbar both encouraged the development of art, literature, architecture, etc. during their rule.

7. In the history of India, Navratna was in the court of both the Gupta emperor Chandragupta II (Vikramaditya) and the Mughal emperor Jalaluddin Mohammad Akbar.

**Navratna in the court of Emperor Chandragupta II (Vikramaditya) :**

1. Amarasimha
2. Dhanvantari
3. Ghatkharpar
4. Kalidasa
5. Kshapanaka
6. Shanku
7. Varahamihira
8. Vararuchi
9. Vetala-Bhatta

**Navratna in the court of Emperor Jalaluddin Mohammad Akbar :**

1. Abul-Fazal
2. Raja Todar Mal
3. Abdul Rahim Khan-I-Khana
4. Raja Birbal (Mahesh Das)
5. Faizi
6. Fakir Aziao-Din
7. Tansen
8. Raja Man Singh I
9. Mulla Do-Piyaza

**Differences between the Gupta Emperor Chandragupta II (Vikramaditya) and the Mughal Emperor Jalaluddin Muhamad Akbar :**

1. The Gupta emperor Chandragupta II (Vikramaditya) was a Hindu religious ruler while the Mughal emperor Jalaluddin Mohammad Akbar was a Muslim religious ruler.

2. The Gupta Emperor Chandragupta II (Vikramaditya) was a famous ruler of ancient India,

while the Mughal emperor Jalaluddin Muhammad Akbar was a famous ruler of medieval India.

3. Samudragupta, the father of the Gupta emperor Chandragupta II (Vikramaditya), was a successful Chakravarti emperor, while Humayun, the father of the Mughal emperor Jalaluddin Muhammad Akbar, was a failed emperor.

**CONCLUSION**

There are many examples in history of two people living the same life. But there are very few examples of two famous and great leaders having the same life.

E.g. Gautam Buddha, the founder of Buddhism and Vardhman Mahavira, the founder of Jainism, Abraham Lincoln and John F. Kennedy, the president of the United States, Chandragupta II (Vikramaditya), the Gupta emperor, and Jalaluddin Muhammad Akbar, the Mughal emperor... etc.

Gautam Buddha, the founder of Buddhism, and Vardhman Mahavira, the founder of Jainism, were in the same situation at the same time. Presidents Abraham Lincoln and John F. Kennedy were 100 years apart. But the two US presidents were in the same era and the situation in the US was similar during their rule.

But there was a gap of about 1200 years between the reigns of the Gupta emperor Chandragupta II (Vikramaditya) and the Mughal emperor Jalaluddin Muhammad Akbar. Chandragupta II (Vikramaditya) was the ruler of ancient India while Jalaluddin Muhammad Akbar was the ruler of medieval India. However, despite the distances and different circumstances of an era, there are significant similarities in the lives and work of these two rulers.

**REFERENCES**

1. *The Gupta Empire, By Radhakumud Mookerji*
2. *Ancient India, By R.C.Mujumdar*
3. *Akbar The Great Mugal, By Vincant Arthur Smith*
4. *Akbar, Emperor of India, By Richard Van Garbe*
5. *History of Medieval India, By Satish Chandra*

Web Site : [https://en.wikipedia.org/wiki/Gupta\\_Empire](https://en.wikipedia.org/wiki/Gupta_Empire)

Web Site : <https://en.wikipedia.org/wiki/Akbar>



# OPTOELECTRONIC DEVICE FOR REMOTE TEMPERATURE CONTROL OF SANITARY UNITS

Sirojiddin Fayozovich Ergashev<sup>1</sup>,

Kuchkarov Akmaljon Axmadaliyevich<sup>2</sup>, Mamasadikova Umida Yusupjonovna<sup>3</sup>

<sup>1</sup>Doctor of Technical Sciences, Professor of Electronics and Instrumentation department, Ferghana Polytechnic Institute, Ferghana, Uzbekistan

<sup>2</sup>PhD, Head of Electronics and Instrumentation department, Ferghana Polytechnic Institute, Ferghana, Uzbekistan

<sup>3</sup>Master of Electronics and Instrumentation department, Ferghana Polytechnic Institute, Ferghana, Uzbekistan

Article DOI: <https://doi.org/10.36713/epra7317>  
DOI No: 10.36713/epra7317

## ANOTATION

*The article discusses the principles of constructing an optoelectronic device without optical systems for remote control of the temperature of solar installations and small objects. A block diagram of the developed device is shown and its principle of action is laid out.*

**KEYWORDS:** *optoelectronic, temperature, amplitude detector, thermal radiation, spectral density.*

## INTRODUCTION

High-performance, economical and safe operation of solar installations requires the use of modern methods and means of measuring quantities that characterize the course of the process and the state of the equipment. Automatic control is logically the first stage of automation, without the successful functioning of which it is impossible to create an automated control system for solar installations.

At high capacities, even the smallest control errors in solar plants result in large absolute energy losses. Therefore, the role of automatic control and management of solar installations is increasing. One of the most pressing problems in solar installations is automatic temperature control. There are many different temperature control devices used in solar technology, but they are mostly contact devices.

The most promising in this sense is the optoelectronic method of temperature control, and in many cases their use turns out to be not only preferable in comparison with contact means for measuring temperature, i.e. thermometers, but the only one possible. This primarily concerns the measurement of the temperature of objects, contact with which is difficult or impossible due to its remoteness or inaccessibility.

## MATERIAL AND METHODS

We have developed an optoelectronic device for remote control of the temperature of small-sized objects, which can be successfully used in the study of the temperature characteristics of solar installations. The block diagram of the optoelectronic device is shown in Fig. 1.

An optoelectronic device for remote monitoring of the temperature of objects contains a monitoring object 1, which, through a modulator 2, is optically connected to the first radiation receiver 3, the output of which is through the first amplifier 4, the first amplitude detector 5 and the first integrator 6 are connected to the first input of the signal ratio obtaining device 13, the second radiation receiver 7, the output of which is through the second amplifier 8, the second amplitude detector 9 and the second integrator 10 is connected to the second

input of the signal ratio acquisition device 13, the output of which is connected with the input of the recording device 14, the control device of the collimated radiation source 12, the input of which is connected to the output of the first amplifier 4, and the output is connected to the input of the collimated radiation source 11 which through reflections from the surface of the controlled object 1 is optically connected to the second radiation receiver 7, the electric motor 15 is a rotor, which is mechanically connected to the axis of rotation of the modulator 2.

Figure 2 shows timing diagrams that explain the principle of operation of the proposed device.

An optoelectronic device for remote control of the temperature of objects operates as follows. The heat flux of radiation  $\Phi_{III1}(\lambda)$  of the object of control 1, which is proportional to its temperature, covers the distance  $l$ , is modulated by modulator 2 and enters the sensitive area of the first radiation receiver. The flux entering the sensitive area of the first radiation detector according to the theory of optoelectronic devices [1,3,6] is defined as:

$$\Phi_{III1}(\lambda) = \tau_c(\lambda) M_{KO}(\lambda) \frac{A_{KO} D_{III1}^2}{4l^2}, \quad (1)$$

where:  $\tau_c(\lambda)$  - spectral transmittance of the atmosphere;  $M_{KO}(\lambda)$  - spectral density of the radiant luminosity of the emitting surface of the controlled object;  $A_{KO}$  - the area of the emitting surface of the controlled object;  $D_{III1}$  - the diameter of the entrance pupil of the first radiation detector;  $l$  - the distance between the controlled object and the first photodetector.

Taking into account that  $M_{KO}(\lambda) = \varepsilon_{KO}(\lambda) M_{\text{чТ}}(\lambda)$  expression (1) will take the form:

$$\Phi_{III1}(\lambda) = \tau_c(\lambda) \varepsilon_{KO}(\lambda) M_{\text{чТ}}(\lambda) \frac{A_{KO} D_{III1}^2}{4l^2}, \quad (2)$$

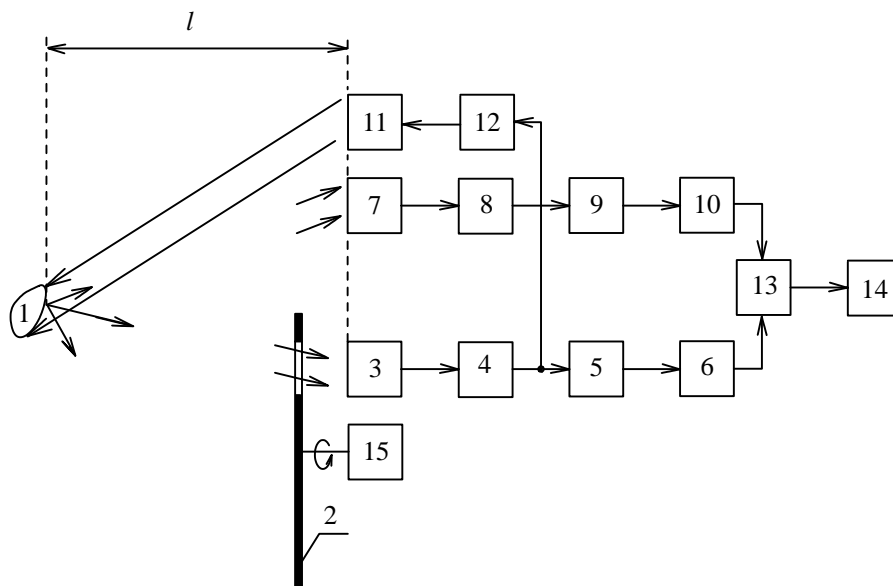


Fig. 1. Block diagram of an optoelectronic device for remote temperature control of solar installations.

where:  $\varepsilon_{KO}(\lambda)$  - spectral coefficient of thermal radiation of the controlled object;  $M_{\text{чТ}}(\lambda)$  - the spectral density of the energy luminosity of the black body.

Considering that the radiation receiver operates in a limited spectral range, then expressions (2) for wavelengths  $\lambda_{1m}$  which corresponds to the maximum sensitivity of the first radiation receiver can be written as:

$$\Phi_{\lambda_{1m} III1} = \tau_{\lambda_{1m} c} \varepsilon_{\lambda_{1m} KO} M_{\lambda_{1m} \text{чТ}} \frac{A_{KO} D_{III1}^2}{4l^2} \quad (3)$$



where:  $\mathcal{E}_{\lambda 1 m_{\kappa O}}$  - spectral coefficient of thermal radiation of the controlled object at wavelengths  $\lambda 1 m$ ;  
 $M_{\lambda 1 m_{\gamma T}}$  - the spectral density of the radiant luminosity of a black body at wavelengths  $\lambda 1 m$ ;  $\tau_{\lambda 1 m c}$  - atmospheric transmittance at wavelengths  $\lambda 1 m$ .

Taking into account the Stefan-Boltzmann law that  $M_{\lambda 1 m_{\gamma T}} = \sigma T^4$  expression (3) will take the form:

$$\Phi_{\lambda 1 m_{\Pi\Pi 1}} = \tau_{\lambda 1 m c} \mathcal{E}_{\lambda 1 m_{\kappa O}} \sigma T^4 \frac{A_{\kappa O} D_{\Pi\Pi 1}^2}{4l^2} \quad (4)$$

Where; T - the temperature of the controlled object;  $\sigma = 5,6697 \cdot 10^{-8} Bm \cdot M^{-2} \cdot K^{-4}$  - Stefan - Boltzmann constant.

The voltage corresponding to expression (4) from the output of the first radiation receiver 3 is amplified by the first amplifier 4, as a result of which an alternating electrical signal is formed at its output (Fig. 2 c), which is fed to the input of the control device of the collimated radiation source 12 and the first amplitude detector 5. The detected signal (Fig. 2 e), from the output of the first amplitude detector 5 is integrated by the first integrator 6 and fed to the first input of the device for obtaining the ratio of signals 13. In this case, the voltage applied to the first input of the device, obtaining the signal ratios 13 can be defined as:

$$U_{\lambda 1 m} = k_1 \Phi_{\lambda 1 m_{\Pi\Pi 1}} = k_1 \tau_{\lambda 1 m c} \mathcal{E}_{\lambda 1 m_{\kappa O}} \sigma T^4 \frac{A_{\kappa O} D_{\Pi\Pi 1}^2}{4l^2}, \quad (5)$$

where:  $k_1 = k_{\Pi\Pi 1} k_{Y1} k_{AD1} k_{IHT1}$  - the total transmission coefficient of the blocks connected in series with the first radiation receiver 3, the first amplifier 4, the first amplitude detector 5 and the first integrator 6;  $k_{\Pi\Pi 1}$  - the transmission coefficient of the first radiation receiver;  $k_{Y1}$  - the transmission coefficient of the first amplifier;  $k_{AD1}$  - transmission coefficient of the first amplitude detector;  $k_{IHT1}$  - transmission coefficient of the first integrator.

When the output signal of the first amplifier 4 acts on the input of the control device of the collimated radiation source 12, an antiphase electrical signal is formed at its output. The latter is fed to the input of the collimated radiation source 11 and causes a pulsed flow of collimated radiation at its output.

Formed flow, the source of collimated radiation 11 is directed to the area of the controlled object 1. In this case, the flow reaching on the surface of the controlled object 1 in the case  $A_{\kappa O} \leq A_{\kappa H}$  defined as:

$$\Phi_{\kappa O \lambda 2} = \tau_{\lambda 2 m c} \Phi_{o \lambda 2} \frac{A_{\kappa O}}{A_{\kappa u}} \quad (6)$$

where:  $A_{\kappa u}$  - cross-sectional area of collimated radiation;  $\tau_{\lambda 2 m c}$  - the transmittance of the atmosphere at wavelengths  $\lambda 2 m$ ;  $\Phi_{o \lambda 2}$  - the initial flux of collimated radiation. In this case, the reflected flux from the surface of the controlled object 1 is determined as:

$$\Phi_{OTP \lambda 2} = \gamma_{\kappa O} \tau_{\lambda 2 m c} \Phi_{o \lambda 2} \frac{A_{\kappa O}}{A_{\kappa u}} \quad (7)$$

where:  $\gamma_{\kappa O}$  - coefficient of reflection from the surface of the controlled object at wavelengths  $\lambda 2$ .

Then the expression for the flux that reaches the sensitive area of the second radiation detector 7 has the form:

$$\Phi_{\lambda 2 m_{\Pi\Pi 2}} = \gamma_{\kappa O} \tau_{\lambda 2 m c}^2 \Phi_{o \lambda 2} \frac{A_{\kappa O} D_{\Pi\Pi 2}^2}{A_{\kappa u} 4l^2}, \quad (8)$$

where:  $D_{\Pi\Pi 2}$  - the diameter of the entrance pupil of the second radiation detector.

## DISCUSSION RESULTS

The voltage corresponding to expression (8) from the output of the second radiation detector 7 is amplified by the second amplifier 8, as a result of which an alternating electrical signal is formed at its output (Fig. 2 d), which is fed to the input of the second amplitude detector 9. The detected signal (Fig. 2 f) c the output of the second amplitude detector 9 is integrated by the second integrator 10 and fed to the second input of the device for obtaining the ratio of signals 13.

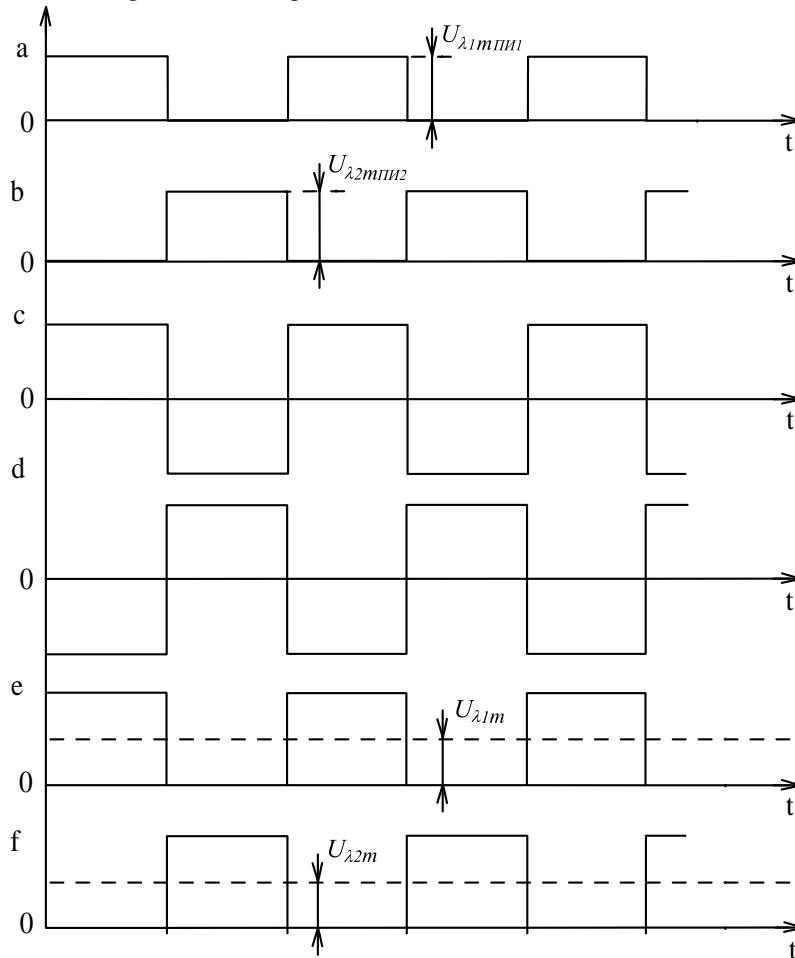


Fig. 2. Timing diagrams of an optoelectronic device.

In this case, the voltage supplied to the second input of the device for obtaining the ratio of signals 13 can be determined as:

$$U_{\lambda 2m} = k_2 \Phi_{\lambda 2m \Pi \Pi 2} = k_2 \gamma_{\kappa o} \tau_{\lambda 2m c}^2 \Phi_{o \lambda 2} \frac{A_{\kappa o} D_{\Pi \Pi 2}^2}{A_{\kappa u} 4l^2}, \quad (9)$$

where:  $k_2 = k_{\Phi \Pi 2} k_{Y 2} k_{A \Delta 2} k_{I \Pi \Gamma 2}$  - the total transmission coefficient of blocks connected in series with the second receiver of radiation 7, the second amplifier 8, the second amplitude detector 9 and the second integrator 10;  $k_{\Phi \Pi 2}$  - the transmission coefficient of the second radiation receiver;  $k_{Y 2}$  - the transmission coefficient of the second amplifier;  $k_{A \Delta 2}$  - the transmission coefficient of the second amplitude detector;  $k_{I \Pi \Gamma 2}$  - is the transfer coefficient of the second integrator.

It is known that optical devices intended for temperature measurement mainly use the transparent region of the atmosphere spectrum [2,4,7].



Therefore, for a small distance between the controlled object and the radiation receiver, it can be considered that  $\tau_{\lambda 1mc} = \tau_{\lambda 2mc} \approx 1$ . Then when using identical electronic units for radiation fluxes  $\Phi_{\lambda 1m III1}$  and  $\Phi_{\lambda 2m III2}$  we have  $k_1 = k_2$ .

Therefore, at the output, the device for obtaining the ratio of signals 13, proportional to the temperature of the controlled object 1, forms the voltage ratio:

$$\frac{U_{\lambda 1m}}{U_{\lambda 2m}} = \frac{A_{ku} \varepsilon_{\lambda 1mc} \sigma T^4}{\gamma_{ko} \Phi_{o\lambda 2}}, \quad (10)$$

or

$$\frac{U_{\lambda 1m}}{U_{\lambda 2m}} = k T^4, \quad (11)$$

where:  $k = \frac{A_{ku} \varepsilon_{\lambda 1mc} \sigma}{\gamma_{ko} \Phi_{o\lambda 2}}$  - constant value. Since solar parabolic concentrators have the coefficient of reflection of the surface of the heat receiver in the near and mid-IR spectral range is constant and amounts to  $\gamma_{\lambda 2KO} = 0,1$ .

Then the temperature of the controlled object is determined as:

$$T_{ko} = 4 \sqrt[4]{\frac{1}{k} \frac{U_{\lambda 1m}}{U_{\lambda 2m}}}. \quad (12)$$

Thus, it can be seen from the last expression that the temperature of the controlled object is proportional to the voltage ratio  $U_{\lambda 1m}$  and  $U_{\lambda 2m}$  which is recorded by the recorder, where  $k$  is accounted for.

## CONCLUSIONS

An important advantage of an optoelectronic device for remote control of the temperature of solar installations is that with the help of this device it is possible to control the temperature with high accuracy when studying the temperature characteristics of solar installations.

## REFERENCES

1. Yakushenkov Yu.G. *Teoriya i raschyot optikoelektronnyh priborov. M.: - Logos, 1999.-480s.*
2. Fuks-Rabinovich L.I., Epifanov M.V. *Optikoelektronnye pribory. L.: - «Mashinostroenie», 1979.-362 s.*
3. A.V. Baholdin, G.E. Romanova, G.I. Cukanova *Teoriya i metody proektirovaniya opticheskikh sistem. Pod redakciei prof. A.A. Shehonina– SPb: SPb NIU ITMO, 2011. – 104 s.*
4. Lebed'ko E.G. *Sistemy opticheskoi lokacii, chast' 3.– SPb: NIU ITMO, 2013. – 110 s.*
5. A. P. Grammatin, G. E. Romanova, O.N. Balacenko. *Raschet i avtomatizaciya proektirovaniya opticheskikh sistem. – SPb: NIU ITMO, 2013. – 128 s.*
7. A.V. Prokof'ev, *Metrologiya optiko-elektronnogo priborostroeniya. – SPb: NIU ITMO, 2012. –103 s.*
8. V. V. Korotaev, G .S. Mel'nikov, S. V. Miheev, V. M. Samkov, YU. I. Soldatov. *Osnovy teplovideniya – SPb: NIU ITMO, 2012 – 122 s.*



## ANALYSIS COMPARATIVE OF FEMINIST RESEARCHES

**Aziza Zoirova<sup>1</sup>, Raima Shirinova<sup>2</sup>**

<sup>1</sup>Senior Teacher, Karshi State University

<sup>2</sup>Doctor of Science, National University of Uzbekistan

Article DOI: <https://doi.org/10.36713/epra7341>

DOI No: 10.36713/epra7341

---

### ANNOTATION

*This article reveals the features of the emergence of literature on feminism in the context of world literature, examines the problems posed by researches in this area and takes into account the scientific discussions of gender scientists. In addition, in the study of feminist literature various approaches, principles and concepts of Russian, English, and French and Uzbek scientists are being studied. The study cites the works of scientists who have identified the place of a number of phenomena in gender literature, such as "gender", "reception", "classical works", "conformity", and "receptive aesthetics". The study examines methods for analyzing materials of gender discourse in feminist literature, comments on the research directions of gender scientists and examines in detail various aspects of gender in the works*

**KEY WORDS:** *feminist literature, gender, women's prose, women's literature, feminist views, women's prose, style, aesthetic literary phenomenon, women's writing.*

---

### КОМПАРАТИВНЫЙ АНАЛИЗ ФЕМИНИСТИЧЕСКИХ ИССЛЕДОВАНИЙ

#### Аннотация

В данной статье раскрываются предпосылки появления литературы о феминизме в контексте мировой литературы, рассматриваются проблемы, поставленные исследователями в этой области, принимаются во внимание научные дискуссии гендерологов в этой сфере. Кроме того, изучаются различные подходы, принципы и концепции российских, английских, французских и узбекских ученых в изучении феминистской литературы. В исследовании приводятся работы ученых, которые определили место ряда явлений в гендерной литературе, таких как «гендер», «рецепция», «классические произведения», «соответствие», «рецептивная эстетика». В исследовании рассматриваются методы анализа материалов гендерного дискурса в феминистской литературе, комментируются направления исследований ученых-гендерологов, а также подробно исследуются различные аспекты гендера в произведениях писателей-представителей феминистического движения.

**Ключевые слова:** феминистическая литература, гендер, женская проза, женская литература, феминистические взгляды, стиль, эстетический литературный феномен, женское письмо.



**Введение.** В последние годы растет объем исследований в области феминизма. Специалисты, ученые-гендерологи обсуждают истоки феминизма в различных дебатах о ранних и самых первых феминистках. Галина Брант в своей работе «Философская антропология феминизма: О природе женщин» цитирует научные взгляды и факты о существовании женщин как индивидуумов в разные эпохи человечества, а также древние мифы об амазонках и о матриархальном правлении. [1,16]. Вторую половину XX века ученый называет «эпохой философской антропологии» феминизма. В данной научной статье рассматриваются такие аспекты, как биологическая природа женщины, психологические характеристики, культурный статус и личные взгляды. Ученый к вопросам изучения природы женщины идет путем гендерного подхода.

Зарубежные исследователи дают разные взгляды о природе женщины.

**- Анализ соответствующей литературы (Literature review).** В женской английской прозе первыми стали Джейн Остин, вслед за ней сестры Бронте, Джорж Эллиот, Элизабет Гаскелл. В основном в своих произведениях писательницы раскрывали судьбу женщины, её образ жизни, её веру, проблемы, переживания. В английской литературе наблюдались разногласия насчет творчества женщин. В частности, английские критики пытаются объяснить особенности женской прозы тем, что автобиографический сюжет, то есть история молодых девушек, укладывается в рамки такой темы как женские внутренние сердечные бунты. О женской прозе критики выражают обоснованные и необоснованные мнения и замечания. Некоторые из них действительно считают, что женщины являются талантливыми, в то время как другие критики считают женщин неопытными, близорукими мечтательницами. Также приводятся гипотезы о том, что им не хватает таланта и навыков, чтобы осветить явления реальной жизни, а некоторые критики положительно отзываются, считая их сильными по своей природе, терпеливыми, обладательницами высокого интеллекта и доброго сердца. Например, Ж.М.Лудло говорит читателям о том, что лучшие произведения, написанные в развитых странах мира, были созданы рукой женщины [2], английский антрополог Ж. Макригор Аллен приводит гипотезы об очень сильно развитом ментальном мышлении у женщин, и о том, что время от времени природа подтачивает их мышление и интуицию [3].

Особенно, когда речь идет об английской литературе, важно отметить, что большинство

романов, увидевших свет в XIX веке, принадлежат перу женщин. Поэтому есть полное право признать XIX век веком «женской прозы» и это явление остается актуальным и в наши дни.

Как было сказано выше, творчество сестер Бронте в результате огромного влияния революций в Европе и движения чартистов в Англии наполнилось романтическими и реалистическими тенденциями. Шарлотта Бронте напрямую обращается к образу чартизма, но ее главной героиней в английском реалистическом романе становится женщина по имени Джейн Эйр, которая борется за свою гражданскую и духовную свободу. Романы Шарлотты Бронте непосредственно связаны с ее личным жизненным опытом. Большую часть своей жизни она проводит в Ховорте (Йоркшир). Ранние прозаические произведения сестер Бронте являются примером великолепных произведений, таких как «Грозовой перевал» Эмили Бронте, «Агнес Грей» Анны Бронте и «Джейн Эйр» Шарлотты Бронте [4,239].

София Бакаева, занимаясь исследованиями французской феминистской литературы, стремится определить место ряда явлений в гендерной литературе, таких как гендерная рецепция, классические произведения, переписка и рецептивная эстетика. Она изучает психолого-романтический роман «Принцесса Клевская» (La Princesse de Clèves, 1678) мадам де Лафайет, «Клевская» (Clèves, 2011) Мари Даррьесек, «Опасные связи» (Les Liaisons dangereuses, 1782) Шодерло де Лакло, «Зимнее очарование» (L'hiver de beauté, 1987) Кристианы Барош, и особенности классических текстов в их произведениях. [5]. Ученый исследует художественные и языковые особенности произведений французских писателей феминистского направления, которые благодаря своим произведениям заняли особое место в мировой литературе.

О. Гаврилина выделяет в русской литературе два основных значения в понятии «женская литература»: «В широком смысле все эти произведения написаны женщинами, автор остается верен традициям феминизма. А в узком смысле - в рамках текстов, основанных на традиционных универсальных проблемах (жизнь и смерть, эмоции и долг, отношения человека и природы, семьи и прочего). [8,22].

*«Я считаю, что можно употреблять термины из разных методологических направлений, в частности нарратологического, психоаналитического, социологического, психологического и т.п., когда их соединяет такая общая задача, как анализ женского текста с гендерной точки зрения. Важно лишь то, что мы принимаем во внимание женский субъект, особые стратегии повествования и*





творчества женщин. Справедливости ради, надо сказать, что не все одобряют такой плюрализм в подходе к тексту и существуют различия уже в определении объекта изучения, т.е. «женской литературы». Однако столкновение разных и даже противоречивых идей может стать основой для подлинной научной дискуссии» [9,32].

**Исследовательская методология (Research Methodology).** В освещении темы был использован ряд методов таких как классификационный, сравнительный, то есть оппозиция гендерного. В мировой литературе а также недавние исследования в узбекской литературе в области феминизма послужили теоретическим источником в данном исследовании.

**- Анализ и результаты.(Analysis and results)**

Действительно, к женской прозе можно подходить с разных сторон, но важно отметить, что противоречивые взгляды, возникшие в результате этих дебатов, носят творческий характер по своему повествовательному стилю. Различные и противоречивые мнения в женской прозе также приводят к научным дебатам и как следствие, к различным новым подходам и теориям.

О.В. Пензина дает подход к женской прозе с гендерной точки зрения во второй половине XIX века. [10]. В работе в основном обсуждается, какой аспект гендера больше всего отражается в творчестве писателей. Автор в своем исследовании основывается на методологических основах существующих гендерных исследований в области философии, социологии, культурологии и литературы, проводимых рядом ученых таких как Г.Мур, Е.Вольф, Э.Елинек, М.Калли, М.Рюткенен, С.Вайгель, Ю.Кристева, Э.Горосс, Э.Шоултер, И.Жеребкина, А.А.Андреев, Н.А.Болохин, М.Н.Габриэлян, Е.А.Здравомыслов, А.В.Криллин, И.Савкина, Е.И.Трофим.

В исследовании представлен подробный анализ различных аспектов гендера в творчестве писательниц-фемисток, комментируется исследование гендерологов, которые определили методы анализа текста гендерного дискурса в феминистской литературе. В частности, Ольга Пензина делает следующий комментарий о влиянии французских писателей на творчество русских писателей, в частности, о влиянии Жорж Санд на Россию: «*Инновационный опыт писательниц XIX века зачастую усваивался мужской литературой и переставал осознаваться как специфически женский, В этом смысле показательна рецепция Жорж Санд в России. Ее творчество оказало колоссальное воздействие на русскую литературу в 1930-1940*

*годы, в которой активно адаптировался опыт французской писательницы. К 1860-1870-е годам отношение к Жорж Санд существенно изменилось: бывшие восторженные поклонники признают ее не как талантливого литератора, а как прекрасную женщину, чудесного человека, истинную христианку (вспомним, к слову, госпожу Кукишину!) Сходные процессы происходили и с восприятием русских писательниц»[11,13].*

Следует напомнить, что писательницы-феминистки выбирали себе мужские имена, псевдонимы, в то время у них были на это обоснованные причины. Из русских писательниц в качестве примера можно привести Надежду Дурову, писавшую под псевдонимом Н.Д.Хвошинская-Крестовский. Писательница настолько ценила свой псевдоним, что даже оставила завещание, что после её смерти её должны похоронить под псевдонимом Александров. Писательницы выбирали такой путь для того, чтобы проявить свой талант в полном представлении и защитить от разных препятствий. Ольга Пензина в своем исследовании уделяет особое внимание типологическим особенностям таких талантливых писательниц второй половины XIX века как Л.И.Веселитская (Микулич), А.А.Вербицкая, Ю.В.Жадовская. В частности, в творчестве Юлии Жадовской выделяет ее своеобразный стиль, проблемы женщин, которые являются главными героинями романа, и их переживания. Особенно в образах писательниц раскрываются различные типы гендерства. Писательница в своих романах раскрывая силу ответственность женщин, главные героини произведений по крайней мере в некоторых случаях зависимость от ситуаций, прокрастинации демонстрируют противоречивый характер жизненного опыта женщин. В данном исследовании раскрываются типологические особенности творчества русских писательниц. Если в творчестве Е.П.Свешниковой отражаются больше феминистические идеи, а в творчестве Л.И.Веселитская-Микулич отражаются отклонения от феминистических взглядов и отражается неспособность проявления чувств и эмоций самостоятельно. М.Вовчок, Ю.В.Жадовская изображают персонажей аннигиляционного, А.А.Вербицкий создаёт средне привлекательные образы героев. В общем, гендерные вопросы в прозе русских писательниц подразделится на разные типологические группы.

Русские ученые в изучении «женской прозы» были удостоверены в том, что в русской поэзии женское перо было острее, а в прозе были более известны писатели-мужчины. Еще одним исследователем этой темы является Елена Кошкарлова, которая «тему женщины» в



современных произведениях исследует в идейном ологическом художественном диапазоне.

В частности, в девятнадцатом веке одной из главных особенностей женской литературы на Западе было создание произведений, основанных на жизненном опыте этих женщин. Основные черты такого взгляда на литературу заключаются в том, что автор - женщина, главный герой - женщина, проблемы в некотором роде связаны с судьбой женщины. [14] Ж.М. Томпкин в XVIII веке отмечал, что большинство крупных эпистолярных романов написано писателями-женщинами [15], в то время как Иан Ватт утверждал, что большинство романов, которые написаны в XIX, принадлежало перу женщин [16].

В нашем исследовании представлены широко известные французские писательницы-феминистки. В качестве примера этому можем привести ряд писателей таких, как Симона де Бовуар, Бенуат Гру, Франсуаза Саган, Кристина де Пизан.

Узбекский ученый Хулкар Мухаммедова в своей статье «Викторианская английская литература» показывает эволюцию развития женской прозы приводит обзор женской прозы, сформировавшейся в период правления королевы Англии Виктории. [6]. В своем небольшом исследовании она сделала глубокий анализ прозы английских писателей, поднятых в них проблем женского движения в целом. Английская и американская научная литература пытается объяснить феномены, посредством которых выражается женская литература, то есть «feminist writings» - феминистские писатели, «womans writings» женская проза. В результате анализа произведений писателей Викторианской эхи ученый доказывает, что эту прозу отличает главные элементы: эмоциональность, романтичность и необычность.

Хулкар Мухаммедова в своем анализе английской викторианской литературы XIX века отражает исторические литературные процессы, европейскую культуру, идеи и темы, образы и персонажи, а также стиль и мастерство в созданных ими произведениях.

Выражается обоснованное мнение, что писателям Викторианской эпохи удалось обогатить сокровищницу английской литературы своими совершенными произведениями [7]. Следует отметить, что специалист по гендерологии Х. Мухамедова в своем исследовании эволюции женской прозы в английской литературе опирается на взгляды критиков.

В данной научной работе ученый отмечает что большая часть творчества Джорж Элиот посвящена женщинам и что они рассказывают

историю жизни женщин, например, о вере, о женщине-фаталистке, о судьбе. Хулкар Мухамедова утверждает, что писательское мастерство в создании образа женщины – это уникальный стиль, средство выражения, а особенно воплощение всего, что характерно для женской прозы. Это феминистическое исследование узбекской литературы и переводоведения в сравнительной перспективе обеспечивает научную основу для многих работ.

### Выводы и предложения (Conclusion/Recommendations).

В данной статье мы исследовали в основном западную женскую литературу XVIII и XIX веков, когда творчество женщин-писательниц процветало, и этот процесс продолжается по сей день.

Основной темой в творчестве писательниц-феминисток, главными действующими лицами являются женщины, этот факт наблюдается во всех исследованиях, проводимых учеными всего мира.

На основе систематизированных материалов доказано, что исследования зарубежных ученых по вопросам организации работы писательниц-феминисток проводились в самых разных направлениях и подходах. Однако научные и практические аспекты данного вопроса узбекскими учеными характеризуется тем, что они не являются объектом какого-либо исследования как целостного и монографического. Это вполне справедливо основано на сравнительной организации переводов произведений французских писателей, и это имеет большое значение в современной литературе и переводоведении.

### Список литературы

1. Брандт Г. *Философская антропология феминизма, Природа женщины*. СПб: Алетейя. 2006. –С.16.
2. *Civil Society in Nineteenth-century Britain and Germany: J. M. Ludlow, Lujo Brentano, and the Labour Question* LAWRENCE GOLDMAN. DOI:10.1093/acprof:oso/9780199260201.003.0006
3. *Mainstreaming politics: Gendering practices and feminist theory*. [https://digital.library.adelaide.edu.au/dspace/bitstream/2440/64322/2/hdl\\_64322.pdf](https://digital.library.adelaide.edu.au/dspace/bitstream/2440/64322/2/hdl_64322.pdf)
4. Мухамедова Х. *Танқидий реализм адабиётида аёллар наслнинг тараққиёт боқичлари*. –Б. 239.
5. Бакаева С.А. *Классика французского романа как фактор гендерной саморефлексии во французской литературе 1980-2000 годов*. Автореф.дисс... канд.филол.наук. –Москва, 2016.



6. Мухаммедова Х. Викторян инглиз адабиётида аёллар насри тадрижи. *Scientific progress. Scientific Journal. Scientificprogress.uz.*
7. Мухаммедова Х. Танқидий реализм адабиётида аёллар насрининг тараққиёт босқичлари.
8. Гаврилина О. Гендер и литература: проблема «женского письма» и «женского чтения» // *Филологические науки.* – 2000. №3. –С. 22.
9. Гаврилина О. Гендер и литература: проблема «женского письма» и «женского чтения» // *Филологические науки.* – 2000. №3. –С. 32.
10. Пензина О.В. Женская проза второй половины XIX века: гендерный аспект авторства. Автореф.дисс.канд.филол.наук. –М 2009.
11. Пензина О.В. Женская проза второй половины XIX века: гендерный аспект авторства. Автореф.дисс.канд.филол.наук. –М 2009. – С.13.
12. Пастухова Е.Е. Русская “женская проза” рубежа XX-XXI веков в осмыслении отечественной и зарубежной литературной критики. Автореф.канд.филол....наук. – Саратов 2010.
13. Пастухова Е.Е. Русская “женская проза” рубежа XX-XXI веков в осмыслении отечественной и зарубежной литературной критики. Автореф.канд.филол....наук. – Саратов 2010. –С.13.
14. Мухаммедова Х. Ианқидий реализм адабиётида аёллар насрининг тараққиёт босқичлари. – Тошкент, 2019.
15. Tompkins J.M. *Geder and Reseption of Victoria novels.* Bangstoke. Macmillan 1996.
16. Watt I. *Do Women a Distinct Nature? Women and Values. Reading in Recent Feminist Philosophy.* California State University, 1986.



# A STUDY OF YOGA AWARENESS FOR PHYSICAL & MENTAL FITNESS AMONG THE POST GRADUATE STUDENTS IN PURULIA DISTRICT DURING THE PANDEMIC SITUATION OF COVID-19

Kunal Karmakar<sup>1</sup>, Dr. Laxmiram Gope<sup>2</sup>

<sup>1</sup>Former Student, Dept of Education Sidho-Kanho-Birsha University, Purulia (W.B)

<sup>2</sup>Assistant Professor, Department of Education, Sidho-Kanho-Birsha University, Purulia (W.B)

---

## ABSTRACT

*In the current troubled times from where whole world surviving, when every sector of work has gained slow, the highest service that we can do for our community is to bring everyone together in unity and solidarity, to face the existential challenge posed by COVID-19. What better opportunity than the International Day of Yoga to send out the clarion call for Unity to humanity at large? Compassion is one of the root principles of Yoga. It is compassion that unites us. Compassion is contagious and transmits faster than any virus – making us stronger. Therefore, to keep it mind with the help or collaboration of the P.G students of Purulia district in West Bengal observer try to make a study on the basis of Yoga awareness for physical fitness among the P.G students in Purulia during the pandemic situation of COVID-19. Here the researcher has tried to set up some objectives. On the basis of objectives researcher try to full-fill the objectives. During the pandemic situation researcher collected the data through online Google Form. The study sample is considered response from 400 P.G in Purulia district. Descriptive statistics has performed to analyze the data which has collected through primary sources in Purulia district. Through the study researcher founded that the awareness of Yoga during the pandemic situation in P.G students is very well. As a daily routine they use Yoga as a cure for preventing themselves from the pandemic situation of COVID-19.*

**KEYWORD:** *yoga, yoga awareness, physical fitness, mental fitness, pandemic situation.*

---

## INTRODUCTION

Corona Virus (COVID-19) is one kind of communicable disease which is caused through a virus. This new virus and disease were unknown when it is 1<sup>st</sup> outbreak Wuhan, China, in December 2019. This virus or disease spread or transmission from affected person to unaffected person through hand-to-hand touch or spit or nearly body contact. It has created a globally health and wealth crisis which has deeply affected on the way of human daily lives or life. In response to the corona virus disease 2019 (COVID-19) pandemic situation every sector of whole over the countries are affected. During the pandemic situation health sector suddenly play a very important role from another sector. Being Increase the humanity level humans are try to do anything.

It is well known that at present scenario to facing the situation there is no alternative to Yoga to lead a healthy a life of peoples. In our humanity power for protect form corona virus. Eveready's from busy schedule, peoples are surviving not only from physical problem but also psychological problem, yoga is only way to overcome the problem. From all these kinds of problem only one thing that is known as Yoga can help to overcome those kinds problem.

## Literature review of the study

1. Yoga helps beat the fear of corona virus. Modern science lets us understand the workings of those yoga methods that have become the test of time, and help us relieve anxiety and relax

By Sohan Singh Published: 29th March 2020  
Objectives of the study: here the researcher tried to



find out that how much yoga can beat the fear of corona virus. Findings of the study: through the study researcher tried to explain the various way of Yoga for beating the corona virus in the pandemic situation.

2. How to celebrate World Yoga Day 2020 during Covid19 By Bulbul Dhawan Published: June 17, 2020 Objectives of the study: here the researcher tried to find out the easiest way for organize the 2020 Yoga during the pandemic situation of COVID-19. Findings of the study: here the researcher tried to explain the easiest way for organize the way of Yoga 2020 during the pandemic situation of COVID-19.

3. Role of Yogic practice during lockdown By Vishwambhar Vasant Jadhav University of Mumbai Published on April 2020 Objective of the study: through the current paper researcher try to find out the various Yogic practices which is very important for every human during the pandemic situation of COVID-19 Thus Finding of the study: through the or on the basis of the foregoing discussion, researcher try to explain the various level of yoga practice or yogic exercise which can help people or humans in many ways during the pandemic situation of COVID-19 and try to explain how peoples can stay physically and mentally fit by practicing yoga and meditation during the pandemic situation.

**STUDY GAP:** Its reveals that the yoga and its therapist value is became growing interest among the people, people perceiving yoga as a unique phenomenon through properly practicing the yoga we can proceed towards batter mental in terms of both health physical as well as mental health. But through the literature reviews it's found that very least number study conducted in this field particularly pandemic situation and yoga practices.

### Rationale of the study:

At present the pandemic situation of COVID-19 from which human beings are going also In today's world uncertainty life style of human society day by day getting so much complicated and challenging for living in a competition society only Yoga can preserve your inner peace through devotion and meditation. Yoga also helps to overcome form depression life of a society. Yoga is the most essential solution for overcome from a stress mind and body and also a healthy humanity power. during the pandemic situation it has proven that only healthy humanity power can protect human society from corona virus or other kinds of disease. Yoga or mediation one can easily transmit his stress body and mind to peace mind and soul.

Therefore, during this situation researcher try to study how much Yoga can prevent human life form

COVID-19 through awareness for physical fitness of P.G students in Purulia district in West Bengal.

### Objectives of the study

1. To find out awareness of Yoga for physical fitness among P.G students of Purulia district during the pandemic situation of COVID-19.
2. To compare the difference awareness of Yoga physical fitness among P.G students with respect to gender in Purulia district during the pandemic situation.
3. To compare the difference awareness of Yoga physical fitness among P.G students with respect to location in Purulia district during the pandemic situation.
4. To compare the difference awareness of Yoga physical fitness among P.G students with respect to their stream in Purulia district during the pandemic situation.

### Hypothesis of the study

1. There has no significance awareness of Yoga physical fitness among the P.G students during the pandemic situation of COVID-19 in Purulia district.
2. There has no significance difference of Yoga physical fitness among the P.G students during the pandemic situation of COVID-19 in Purulia district with respect to their gender identity.
3. There has no significance difference of Yoga physical fitness among the P.G students during the pandemic situation of COVID-19 in Purulia district with respect to their location identity.
4. There has no significance difference of Yoga physical fitness among the P.G students in Purulia district during the pandemic situation of COVID-19 with respect to their stream identity.

### METHODOLOGY OF THE STUDY

a. AREAS OF THE STUDY: This study conducted among the post graduate students of Purulia district in West Bengal.

b. POPULATION OF THE STUDY: Entire population of study has 2000 approximately.

c. SAMPLE OF THE STUDY: Sample of study consists of 400 students. Researcher collected data from these 200 individuals of Purulia district.

d. TOOLS FOR DATA COLLECTION: In this pandemic situation researcher collected data through online quiz on the basis of Google forms. Researcher sends the online quiz form through mail and collect the response or score of data also through mail. Collected score of data analyzed by the researcher through MS EXCEL.

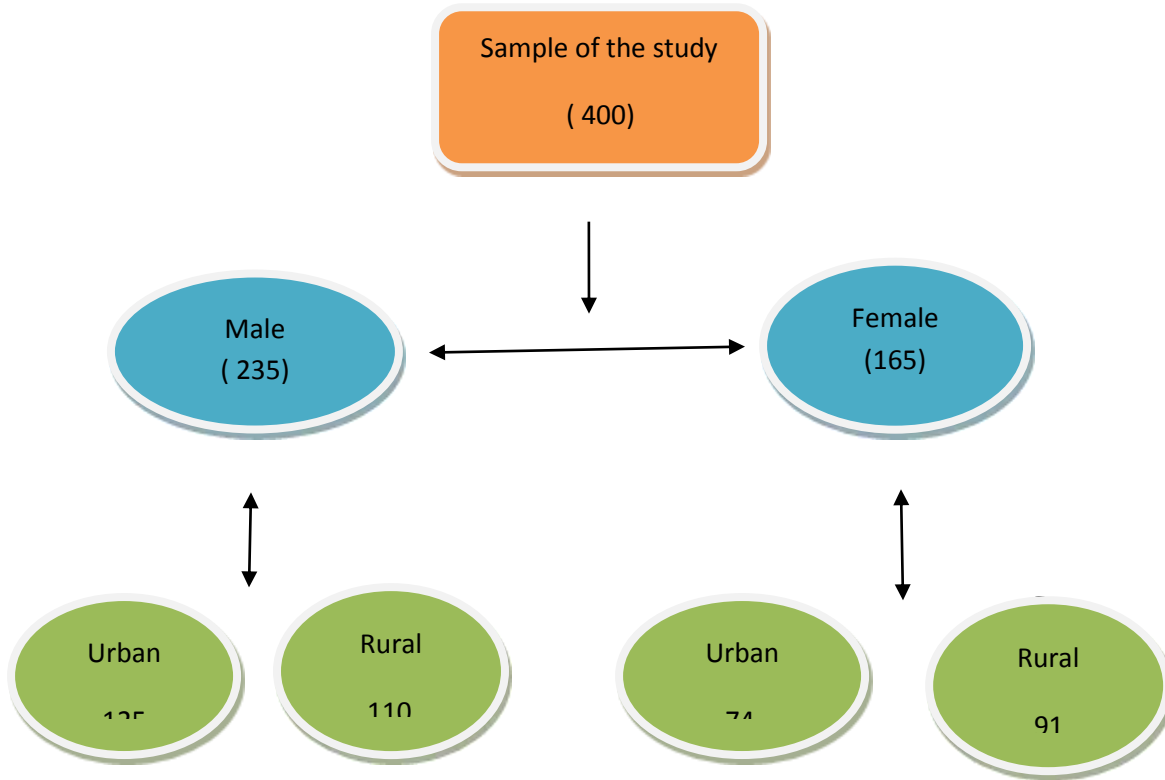
e. ANALYSIS AND INTERPRETATIONS DATA: Researcher calculated t-value and testing null





hypothesis and established relationship among the variable.

**Sample Design of the Study:**



Stream	Participation
Science	116
Arts	150
Commerce	134

**Sampling procedure of the study**

Researcher followed the random sampling procedure for collection of data. Through random sampling procedure researcher collected the sample of P.G students of each stream like as Science, Arts, and Commerce.

**Data collection tool of the study**

Here the researcher used questioners for data collection form identified samples of P.G students in Purulia district. During the lockdown period researcher

used Google form for collection of data from the samples of the study.

**Analysis and interpretation of data**

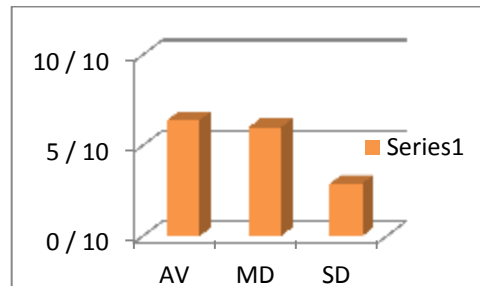
Objective 1. To find out awareness of Yoga physical fitness among P.G students OF Purulia district during the pandemic situation of COVID-19.



Hypothesis 1. 1. There has no significance awareness of Yoga physical fitness among the P.G students during the pandemic situation of COVID-19 in Purulia district.

Table: 1

P.G students of SIDHO KANHO BIRSHA UNIVERSITY	NUMBER OF PARTICIPATION	AVERAGE SCORE	MEDIAN SCORE	STANDARD SCORE
	400	6	6	2.89



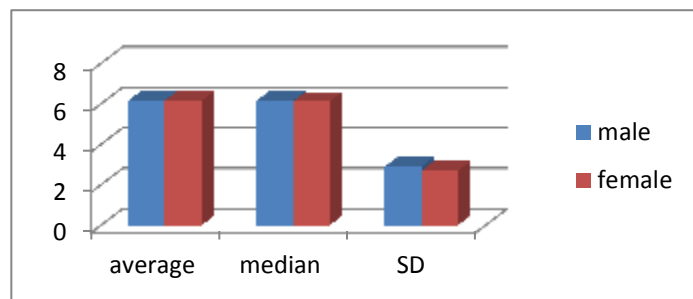
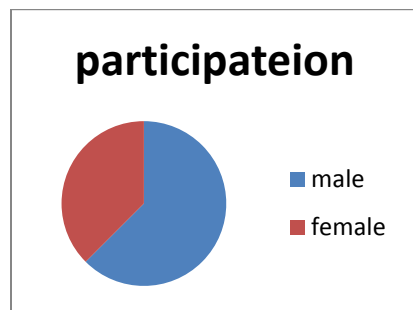
After analyzed the data On the basis of total participant of online quiz program it has found that, the number of participant candidate is 200, the average score of the participant is 6, the median score of the participant is 6 and also the standard score of the participant is 2.89 .

Objective 2. To compare the difference awareness of Yoga physical fitness among P.G students with respect to gender in Purulia district during the pandemic situation.

Hypothesis 2. There has no significance difference of Yoga physical fitness among the P.G students during the pandemic situation of COVID-19 in purulia district with respect to their gender identity.

Table: 2

Gender	Participation	Average score	Median score	Standard score
Male	235	6.17	6.16	2.9
Female	165	6.11	6.12	2.6



After analyzed collected data on the basis of gender it has found that the candidate of male participant is 105, the average score is of male candidate is 6.17, the median score is 6.15 and also the standard score is 2.9, the participant of female candidate is 95, average score is 6.14, median score is 6.12 and also standard score is 2.6.

Objective 3. To compare the difference awareness of Yoga physical fitness among P.G students with respect to location in Purulia district during the pandemic situation.

Hypothesis 3. There has no significance difference of Yoga physical fitness among the P.G students during the pandemic situation of COVID-19 in Purulia district with respect to their location identity.

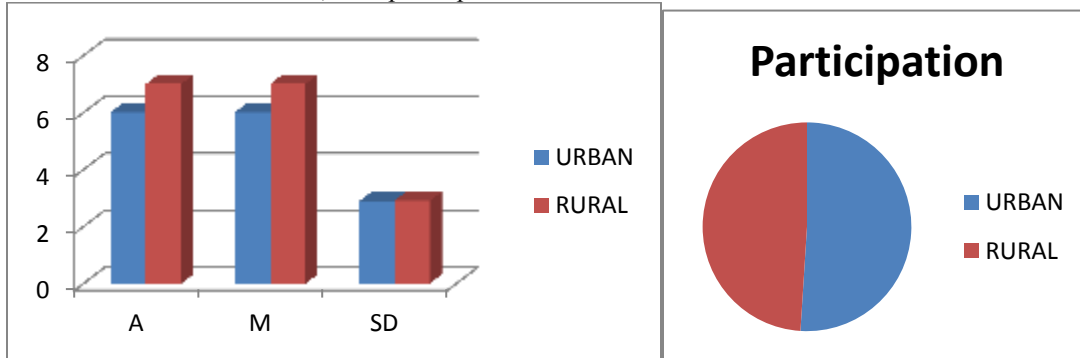


**Table: 3**

Location	Participation	Average score	Median score	SD score
Urban	223	6	6	2.88
Rural	177	7	7	2.9

After analyzed the data on the basis of location it has found that the participation of urban candidate is 102, the average score is 6, the median score is 6 and also the standard score is 2.88 , the participant of rural

candidate is 98, the average score is 7, the median score is 2.88 and also the standard score 2.9 .



Objective 4. To compare the difference awareness of Yoga physical fitness among P.G students with respect to their stream in Purulia district during the pandemic situation.

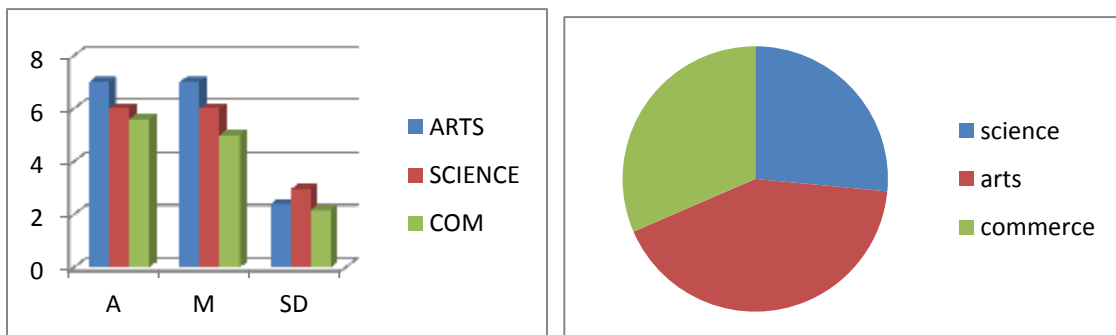
Hypothesis 4. There has no significance difference of Yoga physical fitness among the P.G students in Purulia district during the pandemic situation of COVID-19 with respect to their stream identity.

**Table: 4**

Stream	Participation	Average score	Median score	SD score
Science	116	5.9	6	2.38
Arts	150	6.3	6	2.94
Commerce	134	5.6	5	2.15

After analyzed the data on the basis of stream or department it has found that the participant candidate of science stream is 53, average score is 5.9, median score is 6 and also the standard score is 2.38, the participant candidate of arts is 84 , the average score 6.3 , the

median score 6 , the standard score is 2.94, the participant candidate of commerce is 63 , the average score is 5.6, the median score is 5 and the standard score is 2.15 .



### FINDINGS OF THE STUDY

Through the study it has founded that most of students awareness of Yoga during the pandemic

situation is very high, even they use yoga as a daily routine as a cure for prevention themselves from corona virus, also founded that they try to boosting their



immunity through yoga. With the students secure high score it can be concluded that awareness of yoga during the pandemic is very high. Therefore on the basis of this test of P.G students of we can say that students awareness of towards yoga has very high level and they are well acquainted about the important of Yoga, Pranayam and Mudras and on the basis of this findings it also can be said that in Purulia district P.G students are not only concentrated over the traditional teaching-learning education system activities but also they emphasized on their all round development physical fitness ,mental preparation or psychic during the pandemic situation of COVID-19.The findings of the study are mention below ,

1. There has no significance of Yoga physical fitness awareness among the P.G students during the pandemic situation of COVID-19 in Purulia district.
2. There has no significance difference of Yoga physical fitness awareness among the P.G students during the pandemic situation of COVID-19 in purula district with respect to their gender identity.
3. There has no significance difference of Yoga physical fitness awareness among the P.G students during the pandemic situation of COVID-19 in Purulia district with respect to their location identity.
4. There has no significance difference of Yoga physical fitness awareness among the P.G students in Purulia district during the pandemic situation of COVID-19 with respect to their stream identity.

7. [https://www.researchgate.net/publication/340398081\\_Yoga\\_and\\_Modern\\_life](https://www.researchgate.net/publication/340398081_Yoga_and_Modern_life)
8. <https://www.ncbi.nlm.nih.gov/pmc/articles/PMC3415184/>

## REFERENCES

1. Madanmohan Role of Yoga and Ayurveda in Cardiovascular Disease. [Last accessed on 2011 Sept 11]. Available from: <http://www.fac.org.ar/qcvc/llave/c039i/madanmohan.php>.
2. Ankerberg J, Weldon J. In: 'Yoga' in Encyclopedia of New Age Belief. Eugene OR, editor. United States: Harvest House Publishers; 1996. pp. 593–610. [Google Scholar]
3. Bowker J. The Oxford Dictionary of World Religions. New York: Oxford University Press; 1997. pp. 1058–9. [Google Scholar]
4. Raghuraj P, Ramakrishnan AG, Nagendra HR, Shirley T. Effect of two selected yogic breathing techniques on heart rate variability. *Indian J Physiol Pharmacol.* 1998;42:467–2. [PubMed] [Google Scholar]
5. Kirkwood G, Rampes H, Tuffrey V, Richardson J, Pilkington K, Ramaratnam S. Yoga for anxiety: A systematic review of the research evidence. *Br J Sports Med.* 2005;39:884–91. [PMC free article] [PubMed] [Google Scholar]
6. [https://www.researchgate.net/publication/340679846\\_ROLE\\_OF\\_YOGIC\\_PRACTICES\\_DURING\\_LOCKDOWN](https://www.researchgate.net/publication/340679846_ROLE_OF_YOGIC_PRACTICES_DURING_LOCKDOWN)



# AN EFFECTIVE ASSESSMENT OF DEEN DAYAL UPADHYAY GRAMEEN KAUSHALYA YOJANA (DDU-GKY) IN PROVIDING SKILL TRAINING PROGRAMME FOR YOUTH: A STUDY OF HARYANA STATE

<sup>1</sup>Vaibhav Verma, <sup>2</sup>Dr. Pradeep Singh Chauhan

<sup>1</sup>Research Scholar, Department of Economics Kurukshetra University Kurukshetra

<sup>2</sup>Associate Prof. Department of Economics IIHS, Kurukshetra University Kurukshetra

Article DOI: <https://doi.org/10.36713/epra7381>  
DOI No: 10.36713/epra7381

## ABSTRACT

*Skills development is imperative to sustaining traditional growth and development in a country like India which is experiencing a demographic dividend. It is a huge challenge not only for the government, but also for the private sector and educational institutions to rise up and specialize to make the country's youth employable and ensure that there is no mismatch between demand and the offer. This study examines the role of Deen Dayal Upadhyay Grameen Kaushalya Vikas Yojana (DDU-GKY) in the development of rural youth in the Haryana State. Secondary data (2015-2021) were used for the study. The results show that the interest of the population towards DDU-GKY and the interns recruited has greatly diminished, which is a matter of concern.*

**KEY WORDS:** Demographic Dividend, Inclusive Growth, Smart Cities, Skill India

## INTRODUCTION

India has started to evolve on the world platform due to its dynamic and rapid growth in its gross domestic product. However, this GDP growth lacked inclusiveness in its growth process, which raised major issues such as unemployment, poverty and inequality over the same period. While the eleventh five-year plan (2007-2012) introduced "inclusive growth" as a main objective, so did the main objective of the twelfth five-year plan (2012-2017). To promote inclusive growth, the government should intervene by implementing various public programs at the micro and macro levels, including job creation, infrastructure development, improving access to quality education and healthcare services.

The current pandemic and economic downturn again raise questions about the major challenges of job creation, especially why the Indian economy has not been faster in generating more productive jobs. On the other hand, the increase in the size of the population and the large shifts in migration from rural to urban

areas have worsened the housing situation in urban areas of India, where large numbers of people do not have adequate accommodation with basic amenities. Large number of India's poor remain in rural areas. Many of these people work in casual labor markets in both agricultural and non-agricultural sectors in which there is little return on labor market skills and experience, and where incomes are therefore limited by the marginal product of labor manual work. Given the overall supply and demand conditions, the return on this work may not generate sufficient household income for a household with non-working dependents to exceed the poverty line. While a system of transfers to low-income households can reduce poverty at least in the short term, such transfers place a heavy burden on state budgets and may prevent the state from making productive investments in public resources that lead to long-term sustainable growth and development. On this basis, it would seem desirable to better understand the nature of rural income growth with a view to how best to promote well-paid jobs. Over the last three-and-a-





half decades, there has been a structural shift in the occupational choice among rural workers, particularly rural agricultural workers, with changes in their occupational choices ranging from agriculture to non-agricultural sectors. According to the 38th Round (1983) of the National Sample Survey (NSS) report, around 77 percent of rural households depend on the agricultural sector to sustain their livelihoods. Rural households' dependency on agriculture has declined to 50 percent as per the latest round of the Periodic Labour Force Survey (PLFS) for 2018-19. The primary reasons behind the decline in employment opportunity in the rural area are insufficient public investment for agrarian development, inadequate access to institutional credit, inadequate irrigation facilities, government's poor agriculture-related marketing policies, half-baked land reform policy, and low return from agriculture are responsible for the fall in agricultural employment.

Haryana has recorded the highest unemployment rate in the country, as per the data released by the Centre for Monitoring Indian Economy for June 2021. With a 29.1% unemployment rate, Haryana's unemployment is nearly 2.5 times the national average 12.6%. Despite being a largely agrarian state, employment opportunities for the state's youth in the agricultural sector have declined over time. Rising up to the formidable task of finding gainful employment for the youth of Haryana, who were traditionally engaged in agricultural activities, is to formulate the right policy to ensure stable employment. The slowing economy and shortage of new jobs prompted the northern state of Haryana, where Gurugram is located, to implement a new law last month that bans private companies from hiring workers of other states. Still, there is a serious topic of skill development because it is very difficult to get a job in these national and multi-national companies without it. Deen Dayal Upadhyaya Grameen Kaushalya Yojana (DDU-GKY) is uniquely focused on rural youth between the ages of 15 and 35 years from poor families.

### OBJECTIVE OF THE STUDY

1. Role of skill development training program in youth, Haryana.
2. To get an overview of Deen Dayal Upadhyaya Kaushalya Yojana.
3. Find out employment achievement through DDU-GKY in Haryana based on 2015 to 2021 data.

### LITERATURE REVIEW

**Chizoba, Chitom & Uju (2020)** examined the effect of skills acquisition on youth employability in Nigeria. The results of the study show that the problems faced by young people in acquiring skills in Nigeria are the lack of qualified trainers, lack of facilities, insufficient funding and weaker government monitoring. The results of the study also indicate that entrepreneurial training or skills acquisition has reduced unemployment and crime rates and is the cause of economic growth and development.

**Agrawal & Thakur (2019)** found the impact of Pradhan Mantri Kaushalya Vikas Yojana on youth productivity in the Gwalior region. The research results show that the training methods and activities brought new abilities to the trainees while performing a task and resulted in an increase in productivity. Increased productivity is helpful in earning more livelihoods, promoting them for entrepreneurship and solving their unemployment problem

**Dewangan (2018)** in his article on "Empowering rural youth through Pradhan Mantri Kaushalya Vikas Yojana" described skills development initiatives in rural areas of the country. The aim of this study is to describe the role and main characteristics of Pradhan Mantri Kaushalya Vikas Yojana and his contribution to the empowerment of the rural youth population.

**Pandey and Nema (2017)**, in their article on "Impact of skill India training program among young people", pointed out that a maximum number of young people in the country lack knowledge and expertise in the use of modern technologies. Skills development The program is, therefore, a powerful weapon through which young people can be technically trained to survive in this technological age. Through such programs, young people can also be motivated by entrepreneurship to start their own business. But the existing skills development programs in the country face some challenges such as strong competition in the market for their own work, subsidies to start a new business, lack of awareness related to various policies underway for their workers. advantages and shortage of raw materials.

**Shrivastav & Jatav (2017)** revealed how the different types of programs launched by the Indian government can generate employment opportunities in India with new demands for industrial skills. The study concludes on the general state of available skills capacities, requirements, gaps and initiatives undertaken by the Indian government for skills development. There is an immediate need for therapy for the current skills development strategy in India.



Aggarwal (2016) in his article on “Skills development in India” analyzed the skills development process in India from different angles. The study concluded that in addition to focusing on the quantitative aspect of skilled labor, policymakers should also focus on the qualitative aspect of skills development programs. The current situation requires the country to India to improve the quality of ITIs and work with the private sector to move beyond digital vocational training targets to improve apprenticeship programs.

Sharma and Sethi (2015), through their article on “Skill Development: Opportunities & Challenges in India”, attempted to analyze the gap between existing demand and the supply of skilled labor. Their findings clearly show that India will face the major challenge of closing the skills gap over the coming decades. The skills gap can have a serious impact, not only on employers, but also on the economy as a whole. One of the main concerns is the loss of productivity and income, as many jobs remain vacant for a long time due to the lack of skilled labor. The study highlights how serious it is for government and other stakeholders to work together to create a skilled workforce to fill the skills gap and boost economic growth.

Kanchan & Varshney (2015), reported in their research paper on the impact of skills development strategies and initiatives in India. A study based on secondary data sources found that 80 percent of India's rural and urban workforce have low marketable skills. The study reveals that filling this gap with various skills development initiatives results in a skilled workforce to cope with the global hub.

Kedar (2015), India's labor productivity is lower than that of Asian economies and requires upgrading the skills of the labor force to ensure economic growth.

## METHODOLOGY

The study is based on a review of the literature and secondary data, which includes various articles, circulars, and reports from MoRD, CMIE, and census reports.

## DDU-GKY

The Ministry of Rural Development (MoRD) announced the Deen Dayal Upadhyaya Grameen Kaushalya Yojana (DDU-GKY) Antyodaya Diwas, on 25th September 2014. DDU-GKY is a part of the National Rural Livelihood Mission (NRLM), tasked with the dual objectives of adding diversity to the incomes of rural poor families and cater to the career aspirations of rural youth. DDU-GKY is uniquely focused on rural youth between the ages of 15 and 35 years from poor families. As a part of the Skill India

campaign, it plays an instrumental role in supporting the social and economic programs of the government like the Make In India, Digital India, Smart Cities and Start-Up India, Stand-Up India campaigns. Over 180 million or 69% of the country's youth population between the ages of 18 and 34 years, live in its rural areas. Of these, the bottom of the pyramid youth from poor families with no or marginal employment number about 55 million. At present, this scheme is being operated in 27 states and 3 union territories. Under this scheme, there are 2198 training centers, 1822 projects, 839 project implementing agencies are providing training in 56 sectors and there are more than 600 job roles.

During the year 2020-21, 28687 beneficiaries were provided training and 49396 candidates have been given placements till 31 March 2021. From the date of launch of this scheme till 31st March 2021, about 10.81 lakh candidates have been trained in 56 sectors and 600 trades and 6.92 lakh candidates have been provided placements.

**DDU-GKY Mission:** 1. Reduce poverty by enabling poor households to access remunerative and sustainable employment through employment that provides a regular salary. 2. Diversify the income of poor rural families. 3. Cater to the professional aspirations of rural youth. (MoRD, 2016)

**Implementation Model under DDU-GKY:** Each state has a special role in implementing the DDU-GKY program. States have full power to assess, approve and guide the program in their states after they achieve Annual Action Plan (AAP) status. The States manages fund releasing. DDU-GKY follows a 3-tier implementation model. The DDU-GKY National Unit at MoRD functions as the policy-making, technical support, and facilitation agency. The DDU-GKY State Missions provide implementation support, and the Project Implementing Agencies implement the program through skilling and placement projects. (MoRD,2016)

**Project Funding of DDU-GKY:** DDU-GKY provides financial support for placement skills projects that meet market demand with financial support ranging from Rs. 25,696 to over Rs. 1 lakh per person, depending on the duration of the project and whether the project is residential or non-residential. DDU-GKY finances projects with a training duration of 576 hours (3 months) to 2304 hours (12 months). Funding elements include support for training, board and lodging costs (residential programs), transportation costs, post-placement support costs, career progression and retention support costs. DDU-GKY funds a variety of vocational training programs covering over 250 trades in various industries such as retail, hospitality,



healthcare, construction, automotive, leather, electrical, plumbing, gemstones and jewelry, to name a few. The only mandate is that vocational training be demand-driven and lead to the placement of at least 75% of trainees.

**Courses offered under DDU-GKY:** DDU-GKY mandates two types of training in every course Generic

Training on Soft Skills, English and Information Technology (ii) Trade Specific Skills with a minimum duration of hours with different structured of duration - 3 months, 6 months, 9 months & 12 months, the duration for which are 576 hours, 1152 hours, 1728 hours and 2304 hours respectively.

**Table1: Courses offered under DDU-GKY**

Subject	Minimum Training Duration in Hours			
	For 3 month	For 6 month	For 9 month	For 12 month
	Course	Course	Course	Course
English	60	120	180	240
Soft Skills	20	40	60	80
Computer	80	160	240	320
Trade Specific Training with or without OJT	416	832	1248	1664
<b>Total</b>	<b>576</b>	<b>1152</b>	<b>1728</b>	<b>2304</b>

Source: <http://ddugky.gov.in/>

The training plan can also provide for on-the-job training (OJT) as part of the training module, which cannot exceed 30 days for 3-month training, 60 days for 6-month training, 90 days for a 9-month training course, and 30 days for a one-year course

### Analysis and Interpretation

In Haryana, Deen Dayal Upadhyaya - Grameen Kaushalya Yojana (DDU-GKY) is operated through Haryana State Rural Livelihood Mission (HSRLM). Society works for the empowerment of the poor and poverty reduction by focusing on the livelihood of the poor and weaker sections of the society in rural areas. It

aims to empower poor families to remove all social, economic, cultural, and psychological barriers by promoting institutions of the poor at various levels. An environment conducive to the realization of the full potential and inherent capabilities of the poor will be created through social mobilization – creating and promoting opportunities for the poor. Society has to work to enable the poor people to understand the possibilities of change and bring about the desired change by collective action and participation of the poor in implementation. The district wise target assigned and the total project of this program in Haryana are as follows

**Table 2: DDU-GKY Approved Projects**

Sr No.	District Name	Total Project	Total Target Assigned
1	Ambala	4	14600
2	Bhiwani	8	32470
3	Faridabad	5	13045
4	Fatehabad	2	15660
5	Gurgaon	4	12245
6	Hisar	3	17285
7	Jhajjar	5	20105
8	Jind	3	13800
9	Kaithal	2	15660
10	Karnal	3	16260
11	Kurukshetra	3	18260



12	Mahendragarh	2	10860
13	Mewat	3	10600
14	Palwal	1	2000
15	Panchkula	4	18105
16	Panipat	3	12400
17	Rewari	2	9860
18	Rohtak	4	13400
19	Sirsa	2	15660
20	Sonipat	3	12400
21	Yamunanagar	2	10400

Source: <http://ddugky.gov.in/>

**Table 3: Status of DDU-GKY in Haryana 2015 - 2021 (Till 06 June 2021)**

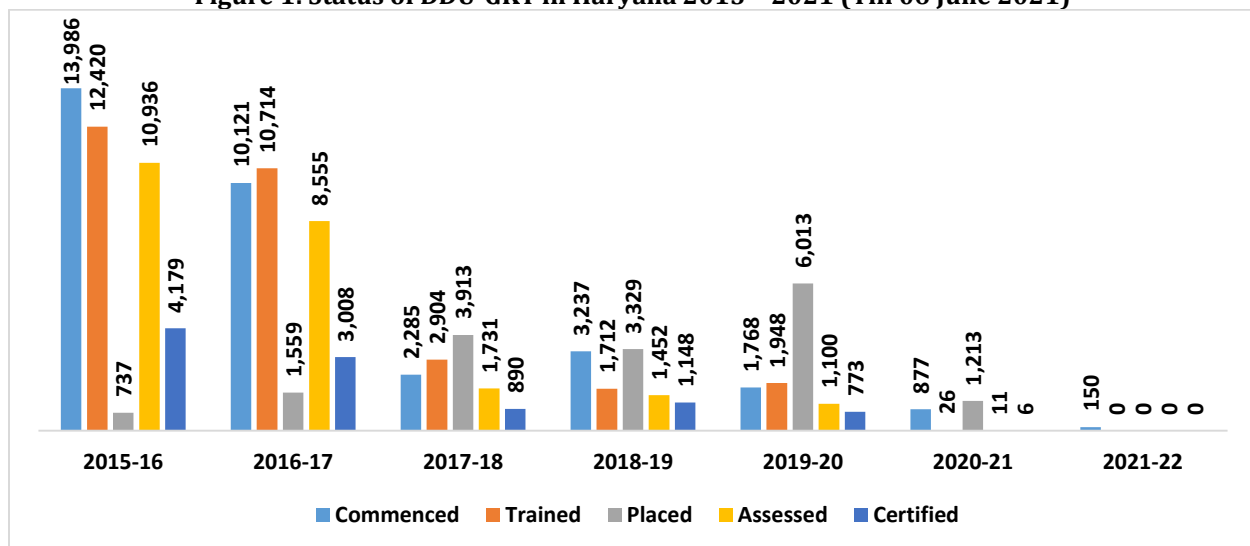
Year	Commenced	Trained	Placed	Assessed	Certified	Overall Target (Till March 2022)
2015-16	13,986	12,420	737	10,936	4,179	66,330
2016-17	10,121	10,714	1,559	8,555	3,008	66,330
2017-18	2,285	2,904	3,913	1,731	890	66,330
2018-19	3,237	1,712	3,329	1,452	1,148	66,330
2019-20	1,768	1,948	6,013	1,100	773	66,330
2020-21	877	26	1,213	11	6	66,330
2021-22*	150	0	0	0	0	66,330

Source: <https://Kaushalyapragati.nic.in/> \* Till June 2021

The above table shows that 2015 to 2021 total 32,424 commenced training, in that 29,724 trainees completed training (91.67%). Total trained persons were 29,724 (91.67%) but placed only 16,764

(56.39%). This shows that the interest of the people towards DDU-GKY and recruited trainees have decreased a lot which is a matter of concern.

**Figure 1: Status of DDU-GKY in Haryana 2015 - 2021 (Till 06 June 2021)**



Source: <https://Kaushalyapragati.nic.in/>



### Drawbacks of the DDU-GKY Training Program

Rural youth who have never worked in the formal sector face many challenges in finding and keeping a job. There are many challenges that affect the recipient's ability to maintain employment or to maintain sustainable employment. These problems exist not only in the workplace but also outside the workplace due to a candidate's poor economic situation and different socio-cultural background as DDU-GKY candidates come from the rural hinterland of Haryana state. There are very specific and people-centered challenges that increase the vulnerability of newly employed rural youth in the workplace. The nature of the problems also depends on trade and geography. For example

- Problem immobilization
- Study gap of trainees after 10th or plus two
- Adjustment problems of trainees
- Family issues
- Health issues
- Not willing to do the job after the free training period.
- Skill mismatch according to industry.
- Low salary

### SUGGESTIONS

The imperative of skills development to support the growth and development of the general public is often overlooked and put on the back burner and still viewed as a non-scalable model due to the high capital required and low return on investment. It is a huge challenge not only for the government but also for the private sector and educational institutions to rise up and specialize to make young people employable and ensure that there is no mismatch between demand and supply. They should also focus on the increased use of modern technology in the workplace/assembly line. In addition, there is a mismatch between the aspirations of young people and the jobs available. Eg. The construction sector generally employs migrant workers from other states.

- Awareness creation about skill training programs
- An aptitude test is needed before training
- Need-based training programs
- Counseling
- Conduct Recreation activities
- Increase training centers

### CONCLUSION

The Indian government is offering a skills development program for the nation's youth by implementing Deen Dayal Upadhyaya Kaushalya Yojana (DDU-GKY). This vocational training and placement program of the Ministry of Rural Development (MoRD). Based on secondary data of Haryana state, it appears that more people come forward to attend such training programs, but interns' placements are very few. So the awareness programs on various skills development programs are very essential in our society and the salary after training needs to increase.

### REFERENCES

1. Agrawal, M., & Thakur, K. S. (2019). *Impact of Pradhan Mantri Kaushalya Vikas Yojana on the Productivity of Youth in Gwalior Region, India. International Journal of Recent Technology and Engineering (IJRTE)*, 8 (4), 801-806
2. Agrawal, P. *Skill Development in India. (2016) International Journal of Engineering Technology, Management, and Applied Sciences. 4 (9): 160-166*
3. Chizoba, O., Chitom, J.-A., & Uju, M. (2020). *Effect of Skill Development on Youth Employability in Nigeria. International Journal of Research in Finance and Management, 3 (1), 33-37.*
4. Dewangan, R. (2018). *Empowering Rural Youth through Pradhan Mantri Kaushalya Vikas Yojana (PMKVY). International Journal of Basic and Applied Research, 8 (8), 945-951.*
5. Kanchan, S., & Varshney, S. (2015). *Skill development initiatives and strategies. Asian Journal of Management Research, 5(4), 666-672.*
6. Kedar, M.S. (2015). *Skill Development in India Challenges and Opportunity. International Research Journal of Multidisciplinary Studies 1(5).*
7. MoRD. (2016). *Deen Dayal Upadhyaya Gramin Kaushalya Yojana.*
8. Pandey A, Nema D.K. (2017). *Impact of Skill India Training Program among the Youth. International Journal of Multidisciplinary Research and Development. 4 (7): 294-299*
9. Sharma E, Sethi S. (2015) *Skill Development: Opportunities & Challenges in India. Gian Jyoti E-Journal. 5(1): 45-55.*
10. Shrivastav, R. K. & Jatav, A. (2017). *An Analysis of Benefits and Challenges of Skilling India. 9th International conference on science, technology, and management, Indian Federation of United Nations Association, New Delhi, ISBN: 9789386171719. Retrieved from <http://conferenceworld.in>.*





## **WEBSITE**

1. <http://ddugky.gov.in>
2. <http://ddugky.gov.in/content/state-skill-development-missions>
3. <https://Kaushalyapragati.nic.in/>
4. <https://www.nationalskillsnetwork.in>
5. <https://www.cmie.com/>



# BENCHMARKING OF STRATEGIC PERFORMANCE MANAGEMENT SYSTEM (SPMS) IN STATE UNIVERSITIES AND COLLEGES IN CALABARZON: DIRECTION FOR ENHANCEMENT ON SPMS OF LAGUNA STATE POLYTECHNIC UNIVERSITY

**Rina J. Arcigal, Ed.D.**

*Laguna State Polytechnic University, College of Engineering*

---

## ABSTRACT

*A research involving Benchmarking of Strategic Performance Management System (SPMS) in State Universities and Colleges in CALABARZON: Direction for Enhancement on SPMS of Laguna State Polytechnic University is described in this paper.*

*The descriptive method of research was employed in this study to gather the necessary information on the Strategic Performance Management System of LSPU: Direction for Enhancement. Specifically, this research intends to determine the : 1.) Profile of the SUC's performance in instruction along with the number of accredited programs, nature of appointment of faculty, academic rank, educational attainment, seminars/trainings attended, research presented, linkages, and extension services. 2.) Significant difference on The Performance of State Universities and Colleges in CALABARZON and Laguna State Polytechnic University in terms of the above mentioned variables and 3.) Develop an action plan base on the findings of Benchmarking of Strategic Performance Management in Laguna State Polytechnic University.*

*This study will be beneficial to administrators. This would serve as an essential input to their institutional planning in coming up with an enhanced strategic performance management. The output can serve as eye opener for them to provide the needs of the clients effectively. The results of the study may be utilized by the Planning Officer to pursue development efforts for the university personnel. It will guide them on how could be of better service to the university. The results will be for personal and professional growth. The study could give the government employees some insights to pursue development efforts in their respective areas of concern. The results can provide future areas of study. The results could also provide an avenue for future research improving the strategic performance management services of their office.*

*The fundamental purpose of higher education, therefore, is not only to develop knowledge and competent graduates in a particular field, but also well- rounded individuals who appreciate knowledge and in a general sense, are open- minded because of it, secure in their identities as individuals and as Filipinos, and cognizant of their in the life of the nation and the larger community.*

**KEYWORDS:** *Benchmarking, CALABARZON, enhancement, Strategic Performance Management System, State Universities and Colleges*

---

## INTRODUCTION

The Civil Service Commission in its effort to objectively measure performance mandated all government agencies to adopt the Revised Performance Evaluation System under CSC MC No. 18, s.1999. Specifically, the system was intended to measure individual performance of all officials and employees. While, Memorandum Circular No. 07, s. 2007 requiring government agencies to establish the Performance Management System-Office performance evaluation System (PMS-OPES). The

system aimed to measure outputs of each office, using OPES reference table.

The past performance evaluation and appraisal system adapted by the different State Universities and Colleges and implemented over the years largely focused only on individual appraisals, which were used in personal actions such as incentives, promotion and separation. But they have not shown that employee performance has contribute to or hindered organizational effectiveness.



The status of accredited programs in Laguna State Polytechnic University lend prestige to member institutions, justified by the possession of quality standards and unremitting efforts to maintain them at high level; help parent to know which program they may send their children to for quality education; make all those engaged in education aware of standards of excellence which they should strive to attain; make possible for those proposing funding and those are fund, know what to support and how much support is needed; and make possible for an evaluated program to know its strength and weaknesses, and in what aspects it needs to develop. Accreditation has also been used as a criterion in administrative decision-making.

With the gaps and weaknesses found in previous performance evaluation system, the Civil Service Commission through the CSC resolution No. 1200481 dated March 16, 2012 issued under CSC memorandum Circular No. 6, s. 2012 directed all government agencies to establish and implemented Strategic Performance Management (SPMS) based from the issued Administrative Order No. 25 dated December 21, 2011 in consonance with Executive order (EO) No. 80, s. 2012 which aims to strengthen performance, monitoring and appraisal system.

Therefore, the need to establish a system that ensures not only the quality of performance, but also interrelations of accomplished outputs and outcomes which flowed from its vision and mandate was enforced.

While policies and systems on performance for faculty and staff members of different state

universities and colleges in CALABARZON, have been in place, it must give way to various strategic shifts such as the strategic performance management system which puts emphasis on major final outputs and outcomes, use of success indicators (measures and targets) in measuring results, and the interventions in development planning.

## METHODOLOGY

The descriptive method of research was employed in this study to gather the necessary data and information that help the researchers plan and carry out descriptive studies, design to provide rich descriptive details about people, places and phenomena. It often involves extensive evaluation and note-taking, as well as in depth narrative. However, a descriptive research design can serve as the first step that identifies important factors, laying a foundation for more rigorous research in the study.

Documentary analysis was used in the study based on the last three years (2015-2017) submitted annual report by different State universities and Colleges in CALABARZON and LSPU.

The frequency and percentage distribution was used to find out number of programs accredited, nature of appointment, academic rank, research paper presented, seminar and trainings attended, extension services and linkages.

Chi-square of homogeneity was used to determine the significant difference on the performance of State Universities and Colleges.

## RESULTS AND DISCUSSION

**Table1. Frequency and Percentage Distribution on the Level of SUC's and LSPU Performance in terms of Number of Accredited Programs**

No. of Accredited Programs	LSPU		SLSU		BATSU		CAVSU		URS	
	F	%	F	%	F	%	F	%	F	%
AACUP										
Level IV	0	0	2	4.54	2	3.31	1	1.21	0	0
Level III	17	26.56	10	22.72	12	18.75	11	13.41	13	17.56
Level II	29	45.31	13	29.54	11	17.18	20	24.90	5	6.75
Level I	18	28.12	19	43.18	39	60.93	50	60.97	51	68.91
No. of Programs not yet Accredited	8	1.33	5	11.36	3	4.68	10	12.19	5	6.75
No. of Accredited Programs	64	99.99	44	99.98	64	100	82	100	39	93.22

It can be notice from table 1, in terms of number of programs accredited in LSPU, there are eighteen (18) or 28.12% of the programs accredited are level I, twenty nine (29) or 45.31% of the programs accredited are level II, seventeen (17) or 26.56% of the programs are level III while no programs offered being accredited in level IV.

In Southern Laguna State University, in terms of number of programs accredited, there are nineteen (19) or 43.18% of the programs accredited are level I, thirteen (13) or 29.54% of the programs accredited are level II, ten (10) or 22.72% of the programs are level III while there are two (2) or 4.54% of the programs offered accredited in level IV.



In Batangas State University, in terms of number of programs accredited, there are thirty nine (39) or 60.93% of the programs accredited are level I, eleven (11) or 17.18% of the programs accredited are level II, twelve (12) or 18.75% of the programs are level III while there are two (2) or 3.31% of the programs offered accredited in level IV.

In Cavite State University, in terms of number of programs accredited, there are fifty (50) or 60.97% of the programs accredited are level I, twenty (20) or 24.90% of the programs accredited are level II, eleven (11) or 13.41% of the programs are level III while there is one (1) or 1.21% of the programs offered accredited in level IV.

**Table 2. Frequency and Percentage Distribution on the Level of SUC's and LSPU Performance in terms of Nature of Appointment**

Nature of Appointment	LSPU		SLSU		BATSU		CAVSU		URS	
	F	%	F	%	F	%	F	%	F	%
Permanent	201	58.43	225	43.26	432	43.99	228	27.14	504	91.47
Contractual (full-time)	100	29.06	13	2.50	458	46.63	460	54.76	25	4.53
Contractual (part-time)	5	1.45	282	54.23	92	9.36	75	8.92	0	0
Temporary	38	11.04	0	0	0	0	77	9.16	22	3.99
Total No. of Faculty	344		520		982		840		551	

Table 2 shows that in terms of appointment in LSPU, two hundred (200) or 58.43% are permanent, one hundred (100) or 29.06% are contractual in full time basis, five (5) or 1.45% are contractual in part time basis and thirty eight (38) or 11.04% are temporary.

In SLSU, two hundred twenty five (225) or 43.26% are permanent, thirteen (13) or 2.50% are contractual in full time basis, two hundred eighty two (282) or 54.23% are contractual in part time basis and zero (0) or 0.00% are temporary.

In BATSU, four hundred thirty two (432) or 43.99% are permanent, four hundred fifty eight (458) or 46.63% are contractual in full time basis, ninety two (92) or 9.36% are contractual in part time basis and zero (0) or 0.00% are temporary.

In CAVSU, two hundred twenty eight (228) or 27.14% are permanent, four hundred sixty (460) or 54.76% are contractual in full time basis, seventy

In University of Rizal System, in terms of number of programs accredited, there are fifty-one (51) or 68.91% of the programs accredited are level I, five (5) or 6.75% of the programs accredited are level II, thirteen (13) or 17.56% of the programs are level III while no accredited programs in level IV.

Len (2012), pointed out that accreditation of higher education varies by jurisdiction and may focused on either or both the institution or the individual programs of study. Higher education accreditation has long been establishes as a peer review process coordinated by accreditation commissions and member institutions.

five (75) or 8.92% are contractual in part time basis and seventy seven (77) or 9.16% are temporary.

In URS, five hundred four (504) or 91.46% are permanent, twenty five (25) or 4.53% are contractual in full time basis, zero (0) or 0.00% are contractual in part time basis and twenty two (22) or 3.99% are temporary.

Martinez (2009), noted that before hiring workers, available jobs have to be classified and corresponding job information have to be described in terms of duties and responsibilities. Qualifications of which must be defined in job specifications. The values that derived from the job specifications and job descriptions overweigh the cost, time and effort in preparing them. Job design determines the number of place and order in which tasks are to be done and the amount of power involved. Job evaluation and the costing of each job are based on the data contained in the job description and job specification.



**Table 3. Frequency and Percentage Distribution on the Level of SUC's and LSPU Performance in terms of Academic Rank**

Academic Rank	LSPU		SLSU		BATSU		CAVSU		URS	
	F	%	F	%	F	%	F	%	F	%
University Professor	1	0.29	1	0.19	1	0.23	2	0.23	1	0.17
Professor	9	2.65	14	2.69	17	3.93	25	2.97	21	3.77
Associate Professor	42	12.38	39	7.5	56	12.96	35	4.16	84	15.10
Assistant Professor	118	34.80	115	22.11	135	31.25	77	9.16	210	37.76
Instructor	170	50.14	351	67.5	223	51.62	701	83.45	240	43.16
Total No. of Faculty	339		520		432		840		556	

Table 3 shows that in terms of academic rank in LSPU, one hundred seventy (170) or 50.14% are instructor, one hundred eighteen (118) or 34.80% are assistant professor, forty two (42) or 12.38% are associate professor, nine (9) or 2.65% are professor and one (1) or 0.29% is university professor.

In SLSU, three hundred fifty one (351) or 67.50% are instructor, one hundred fifteen (115) or 22.11% are assistant professor, thirty nine (39) or 7.5% are associate professor, fourteen (14) or 2.69% are professor and one (1) or 0.19% is university professor.

In BATSU, two hundred twenty three (223) or 51.62% are instructor, one hundred thirty five (135) or 31.25% are assistant professor, fifty six (56) or 12.96% are associate professor, seventeen (17) or 3.93% are professor and one (1) or 0.23% is university professor.

In CAVSU, seven hundred one (701) or 83.45% are instructor, seventy seven (77) or 9.16% are assistant professor, thirty five (35) or 4.16% are

associate professor, twenty five (25) or 2.97% are professor and one (1) or 0.29% is university professor.

In URS, two hundred forty (240) or 43.16% are instructor, two hundred ten (210) or 36.76% are assistant professor, eighty four (84) or 15.10% are associate professor, twenty one (21) or 3.77% are professor and one (1) or 0.17% is university professor.

Aronson, et al. (2008) said that the present work provides empirical evidence to ascertain the implications of academic rank on the job satisfaction of academicians in Northern Cyprus. Data was obtained from 412 academicians. Results indicate that job satisfaction does not progressively increase with academic rank as might be expected. Out of the 20 aspects of the job examine, only 4 aspects, namely advancement, compensation, co-workers, and variety, were statistically significant with academic rank. In general, results indicate the degree of low satisfaction levels that exist among academic.

**Table 4. Frequency and Percentage Distribution on the Level of SUC's and LSPU Performance in terms of Educational Attainment**

Educational Attainment	LSPU		SLSU		BATSU		CAVSU		URS	
	F	%	F	%	F	%	F	%	F	%
Doctorate Degree	52	15.33	37	7.11	59	6.00	58	<b>6.90</b>	101	<b>18.33</b>
Doctorate Degree (CAR)	1	0.29	0	0	0	0	0	<b>0</b>	41	<b>7.44</b>
MA/MS with Doctorate Units	91	26.84	0	0	115	11.71	84	<b>10.00</b>	59	<b>10.70</b>
Master's Degree holder	98	28.90	187	35.61	155	15.78	212	<b>25.23</b>	162	<b>29.40</b>
Master's Degree (CAR)	3	0.88	0	0	0	0	0	<b>0</b>	53	<b>9.61</b>
Master's Degree with Units	91	26.84	0	0	477	48.57	317	<b>37.73</b>	102	<b>18.51</b>
Baccalaureate Degree	3	0.88	296	56.92	176	17.92	169	<b>20.11</b>	33	<b>5.98</b>
Total No. of Faculty	339		520		982		840		551	

It is reflected in Table 4 that in terms of educational attainment, of the faculty of LSPU, there are three (3) or 0.88% are baccalaureate degree holder, ninety one

(91) or 26.84% have master's degree with units, three (3) or 0.88% have master's degree having completed academic requirement, ninety eight (98) or 28.90%





are master's degree graduate, ninety one (91) or 26.84% have MA/MS with doctorate units, one (1) or 0.29% have doctorate degree having completed academic requirement and fifty two (52) or 15.33% have doctorate degree.

In SLSU, two hundred ninety six (296) or 56.92% are baccalaureate degree holder, zero (0) or 0.00% have master's degree with units, zero (0) or 0.00% have master's degree having completed academic requirement, one hundred eighty seven (187) or 35.61% are master's degree graduate, zero (0) or 0.00% have MA/MS with doctorate units, zero (0) or 0.00% have doctorate degree having completed academic requirement and thirty seven (37) or 7.11% have doctorate degree.

In BATSU, one hundred seventy six (176) or 17.92% are baccalaureate degree holder, four hundred seventy seven (477) or 48.57% have master's degree with units, zero (0) or 0.00% have master's degree having completed academic requirement, one hundred fifty five (155) or 15.78% are master's degree graduate, one hundred fifteen (115) or 11.771% have MA/MS with doctorate units, zero (0) or 0.00% have doctorate degree having completed academic requirement and fifty nine (59) or 6.00% have doctorate degree.

In CAVSU, one hundred sixty nine (169) or 20.11% are baccalaureate degree holder, three hundred seventeen (317) or 37.73% have master's degree with units, zero (0) or 0.00% have master's

degree having completed academic requirement, two hundred twelve (212) or 25.23% are master's degree graduate, eighty four (84) or 10.00% have MA/MS with doctorate units, zero (0) or 0.00% have doctorate degree having completed academic requirement and fifty eight (58) or 6.90% have doctorate degree.

In URS, one thirty three (33) or 5.98% are baccalaureate degree holder, one hundred two (102) or 18.51% have master's degree with units, fifty three (53) or 9.61% have master's degree having completed academic requirement, one hundred sixty two (162) or 29.40% are master's degree graduate, fifty nine (59) or 10.70% have MA/MS with doctorate units, forty one (41) or 7.44% have doctorate degree having completed academic requirement and fifty one hundred one (101) or 18.33% have doctorate degree.

Guerrero (2007) contends that educational attainment is the degree earned by a person before practicing his present job. Continuous accumulation of education knowledge through post graduate studies and professional training are believed to be preparation for potential school administrator.

Cruz (2004) expressed that today's processes of acquiring knowledge demands learning much beyond what has been acquired in four years of obtaining educational courses. It seems that completion of formal studies is an indicator of knowledge and ability.

**Table 5. Frequency and Percentage Distribution on the Level of SUC's and LSPU Performance in terms of Seminars/Trainings/Conferences Attended**

Seminars/Trainings/Conferences Attended	LSPU		SLSU		BATSU		CAVSU		URS	
	F	%	F	%	F	%	F	%	F	%
International	4	1.17	3	0.57	26	2.64	5	0.59	19	<b>3.44</b>
National	15	4.42	3	0.57	31	3.15	45	5.35	102	<b>18.51</b>
Regional/Local	13	3.83	5	0.96	16	1.62	154	18.33	83	<b>15.06</b>
Total	32	9.43	11	2.11	73	7.43	301	35.83	204	<b>37.02</b>
Total No. of Faculty	339		520		982		840		551	

From Table 5, it shows that LSPU have thirteen (13) or 3.83% in terms of seminars, trainings, and conferences attended in regionally or locally, fifteen (15) or 4.42% in national level and four (4) or 1.17% in international level.

In SLSU, five (5) or 0.96% in terms of seminars, trainings, and conferences attended in regionally or locally, three (3) or 0.57% in national level and three (3) or 0.57% in international level.

In BATSU, sixteen (16) or 1.62% in terms of seminars, trainings, and conferences attended in regionally or locally, thirty one (31) or 3.15% in

national level and twenty six (26) or 2.64% in international level.

In CAVSU, one hundred fifty four (154) or 18.33% in terms of seminars, trainings, and conferences attended in regionally or locally, forty five (45) or 5.35% in national level and five (5) or 0.59% in international level.

In URS, eighty three (83) or 15.06% in terms of seminars, trainings, and conferences attended in regionally or locally, one hundred two (102) or 18.51% in national level and nineteen (19) or 3.44% in international level.



**Table 6. Frequency and Percentage Distribution on the Level of SUC's and LSPU Performance in terms of Research Output Presented**

Seminars/Trainings/Conferences Attended	LSPU		SLSU		BATSU		CAVSU		URS	
	F	%	F	%	F	%	F	%	F	%
International	7	8.97	24	34.78	58	25.21	18	36.00	16	50.00
National	11	14.10	6	8.69	40	17.39	5	10.00	15	46.87
Regional	3	3.84	5	7.24	37	16.08	2	40.00	1	3.12
Institutional	20	25.64	0	0	0	0	0	0	0	0
Total No. of Faculty Researches	78		69		230		50		32	

From Table 6, it shows that LSPU twenty (20) or 25.64% in terms of research output presented in institutional level, three (3) or 3.84% in regional level, eleven (11) or 14.10% in national level, and seven (7) or 8.97% in international level.

In SLSU, zero (0) or 0.00% in terms of research output presented in institutional level, five (5) or 7.24% in regional level, six (6) or 8.69% in national level, and twenty four (24) or 34.78% in international level.

In BATSU, zero (0) or 0.00% in terms of research output presented in institutional level, thirty seven (37) or 16.08% in regional level, forty (40) or

17.39% in national level, and fifty eight (58) or 25.21% in international level.

In CAVSU, zero (0) or 0.00% in terms of research output presented in institutional level, two (2) or 40.00% in regional level, five (5) or 10.00% in national level, and eight (18) or 36.00% in international level.

In URS, zero (0) or 0.00% in terms of research output presented in institutional level, one (1) or 3.12% in regional level, fifteen (15) or 46.87% in national level, and sixteen (16) or 50.00% in international level.

**Table 7. Frequency and Percentage Distribution on the Level of SUC's and LSPU Performance in terms of Linkages**

Seminars/Trainings/Conferences Attended	LSPU		SLSU		BATSU		CAVSU		URS	
	F	%	F	%	F	%	F	%	F	%
International	15	8.62	17	5.00	16	6.89	22	7.23	19	11.72
National	3	1.72	5	1.47	14	6.03	18	5.92	9	5.55
Regional/Local	156	89.65	318	93.52	202	87.06	264	86.84	134	82.71
Total	174		340		232		304		162	

In can be gleaned from table 7 that on the number of linkages, LSPU have one hundred fifty six (156) or 89.65 % regional and local linkages, three (3) or 1.72% for national and fifteen (15) or 8.62% are international linkages.

In SLSU, three hundred (318) or 93.52 % regional and local linkages, five (5) or 1.47% for national and seventeen (17) or 5.00% are international linkages.

In BATSU, two hundred two (202) or 87.06 % regional and local linkages, fourteen (14) or 6.03% for national and sixteen (16) or 6.89% are international linkages.

In CAVSU, two hundred sixty four (264) or 86.84 % regional and local linkages, eighteen (18) or 5.92% for national and twenty two (22) or 7.23% are international linkages.

In URS, one hundred thirty four (134) or 82.71 % regional and local linkages, nine (9) or

5.55% for national and nineteen (19) or 11.72% are international linkages.

Lucido (2007), linkages can be explained as across organizations or partnership just like the knowledge network. It must be transparent with a common purpose. This common purpose can serve as a larger social identity that transcends members' specific, organizational environment. Partnership implies the spirit of quality. It is compose of two big C-s Consultation and Consensus. Equality refers to equal dignity. It does not necessarily mean equality in the sharing of resources for the blossoming of the partnerships. In a partnership, one party may be more blessed than the other and, therefore, is capable of sharing more than the other. Thus, partnership is likened to a relationship called mutualism in biology that both parties benefit from the relationship.



**Table 8. Frequency and Percentage Distribution on the Level of SUC's and LSPU Performance in terms of Extension Services**

Extension Services	LSPU		SLSU		BATSU		CAVSU		URS	
	F	%	F	%	F	%	F	%	F	%
No. of Recognized extension Programs or Project Implemented	19	25.33	91	95.78	23	29.48	23	34.32	16	20.00
No. of Persons Trained/ Benefited	<b>3,624</b>	<b>88.5%</b>	<b>25,149</b>	<b>90.01%</b>	<b>15,123</b>	<b>82.90%</b>	<b>8,167</b>	<b>72.30%</b>	<b>3,463</b>	84.71%
No. of Faculty involved in extension services	75	64.2%	95	89.7%	78	90.02%	67	75.1%	80	85.4%

In can be seen from Table 8 that Laguna State Polytechnic University, Southern Luzon State University, Batangas State University, Cavite State University and University of Rizal System had

nineteen (19) or 25.33%, ninety one (91) or 95.78%, twenty three (23) or 34.32%, and sixteen (16) or 20.00% recognized extension programs respectively.

**Table 9. Chi-Square Test of Homogeneity on the Performance of SUC's in CALABARZON and Laguna State Polytechnic University**

Variables	df	X <sup>2</sup> c	Significance	Verbal Interpretation
No. of Programs Accredited	31	165.34	0.000	Significant
Nature of Appointment	11	1214.01	0.000	Significant
Academic Rank	12	236.64	0.002	Significant
Educational Attainment	16	1,200.53	0.001	Significant
Seminars/Training Attended	9	531.12	0.000	Significant
Research Presented	9	109.06	0.000	Significant
Linkages	7	532.87	0.003	Significant
Extension Services	4	46.98	0.001	Significant

It can be noticed from Table 9 that it was statistically found out that there is a significant difference on the performance of State Universities and Colleges in CALABARZON and Laguna State Polytechnic University in terms of the program accredited, nature of appointment, academic rank, educational attainment, seminars and training attended, research presented, linkages and extension services since the obtained probability values are within the range of 0.000 to 0.003 did not exceed at 0.05 level of significance.

The findings was supported by the study of Navarro (2005) on the work centers on the analysis framework, on a new kind of student and on these students' specific demands, specifically on the demands satisfied through short courses aimed at updating previously acquired knowledge. Most prior works focus on analyzing the satisfaction with university degrees and on the educational offer that these organizations can provide, such as continuing education and/or complementary courses.

According to Fullado (2006), it is important that the factor of formal schooling required to satisfactorily do their job must be taken into account and so is the applicants' eagerness to continue improving his qualification and education attainment.

For her, it is equally important that even though the minimum educational requirements for the job must be met, the applicant's educational qualification must be so high as to make over qualified for the job because she further states that educational background of an employees is not a development of specific skills among those already in the labor force through training.

## CONCLUSIONS

The following conclusions were drawn based on the result of the study.

1. The performance of State Universities and Colleges in CALABARZON and Laguna State Polytechnic University depends on the number of programs accredited, nature of appointment, academic rank of the faculty, educational attainment, seminars/trainings/conferences attended, research presented, linkages, and extension services.
2. Most of the accredited programs in SUC's and Laguna State University are granted accredited level status on varied level, more than half of the faculty members in LSPU and URS are permanent. Majority of the



faculty in SLSU finished Baccalaureate degree. Most of the faculty members in CAVSU and URS attended regional trainings and conferences.

## RECOMMENDATIONS

On the basis of the result and conclusions derived from the study, the following are highly recommended.

1. Strengthen the national and international linkages of the different State Universities and Colleges in CALABARZON and encourage the faculty members to enroll in Post Graduate Program for their professional advancement.
2. Promote faculty empowerment through scholarship, seminars, trainings, research presentation, engage in extension services, benchmarking, enrolled in graduate program and faculty exchange.
3. Enforce the implementation of proposed plan for Strategic performance Management System (see attached Action Plan) and provide a unified format of annual report of different State Universities and Colleges in CALABARZON.

## REFERENCES

1. Bruner, Thomas LD., (2010). *The Process of Education*. Cambridge, MA; Harvard University Press.
2. Martinez, Lourdes Veronica Q., "the Implementation of Integrative Teaching in English, Mathematics and Science in Public Elementary Schools in Morong District." *Unpublished Master's Thesis*, (2009).
3. Miranda, Thelma F., *Personal Traits and Training Needs Of Student Teachers in the Eastern Part of Rizal*, Technological university of the Philippines, Manila (2008).
4. Bayer, Alan E., *American Institute for Research*, Stanford University, California, USA, (2010).
5. Lenn, Marjorie Peace, (2012), *Global Trends in Quality Assurance in Higher Education*, *World Education News and Reviews*, v.5, no. 2, Spring.
6. Navarro, Mercedes, (2011), *A New Management Elements for Universities: Satisfaction with the offered courses*, *International Journal of Educational Management*, Emerald Group Publishing.
7. Bayer, H. (2010), *STVEP: it's Role on Student Productivity, Socio-EcoDevelopment*.
8. AACUP 2014
9. AACUP Master Survey Instrument 2010.



# DESIGN FEATURES OF THE GRATE CLEANERS COTTON - RAW FROM A LARGE LITTER

Nodira Mirzakulova<sup>1</sup>, Odil Turaev<sup>2</sup>

<sup>1</sup>Teacher of the Department of Technological Machinery and Equipment, Bukhara Engineering Technological Institute, Bukhara, Uzbekistan

<sup>2</sup>Master's student of the Bukhara Engineering Technological Institute, Bukhara, Uzbekistan

---

## ABSTRACT

*The article provides information on the design and operation of machines for cleaning raw cotton from coarse litter. The article also provides an analysis of the work done to improve the working bodies of the machine for cleaning cotton from large weeds.*

---

## INTRODUCTION

In the world, research work is carried out for the cotton ginning industry aimed at the development of innovative techniques and technologies that provide for the effective use of modern achievements of science and technology, and the modernization of existing ones. In this industry, including the development of effective, resource-saving designs of working bodies, grates of cotton cleaners from large litter is of great importance.

In our republic, special attention is paid to the creation of high-performance technological machines and equipment, their control systems for technological processes of primary processing of cotton. When performing this task, it is important, among other things, to create effective designs of grates for cleaning cotton from coarse litter and introduce them into production in order to obtain products of a given quality according to the initial quality indicators of raw cotton.

## LITERATURE REVIEW

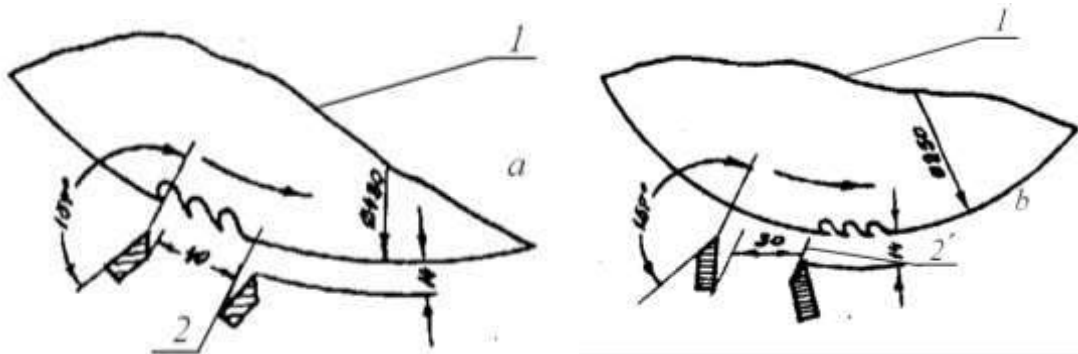
Used in production, the construction of raw cotton cleaners from large trash impurities consists of two main parts, a working body in the form of a rotating serrated cylinder and a baffle device for deflecting large trash impurities (grates). The use of

stationary grates of circular cross-section in the cleaner allows the separation of large trash impurities (see Fig. 2). At the same time, the main disadvantage of these grates with the arrangement of grates with gaps is influenced by the large escape of cotton volatiles to waste, which becomes a mandatory use of the regeneration section in the cotton processing line [1].

In work [2] it was found that when using trihedral grates at an angle of  $157^{\circ}$  to the radius of the serrated cylinder with a gap between the grates equal to 40 mm, the cleaning effect of the machine is significantly increased.

In the ChKh-3 cleaners, grate bars with a trapezoidal section with face dimensions of 25, 16, 12 and 10 mm CHKH-3M were used. At the same time, it was revealed that triangular and trapezoidal grates contribute to significant damage to seeds. The grates have the same size of the working edge as in the triangular grates. The main advantages of grates with a flat working (triangular, trapezoidal) face is to ensure an increase in the force of impact interaction with cotton. This leads to an increase in the cleaning effect of raw cotton. The disadvantages of these grates are the increased formation of free fiber, as well as some damage to the fiber and cotton seeds.





1-barbed cylinder, 2-trapezoidal grates.

Figure 1. a) Working area of the cleaner CHH-3M2 with trapezoidal grates, b) Working area of the purifier OXP-3 with trapezoidal grates.

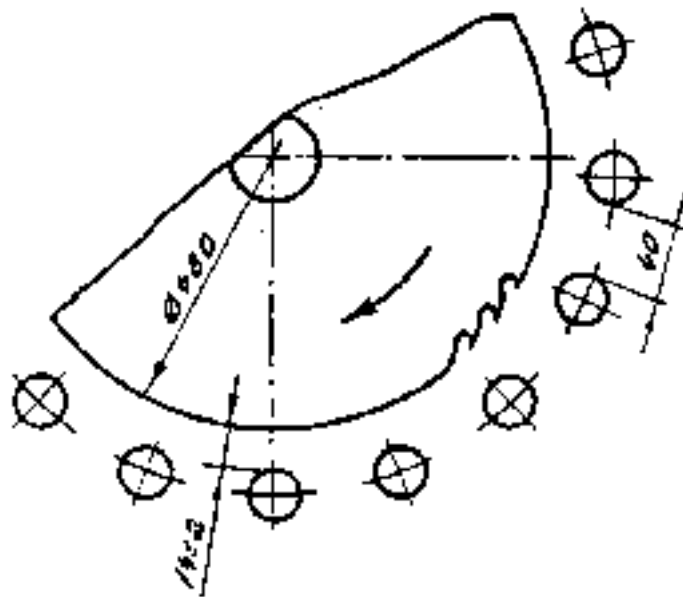


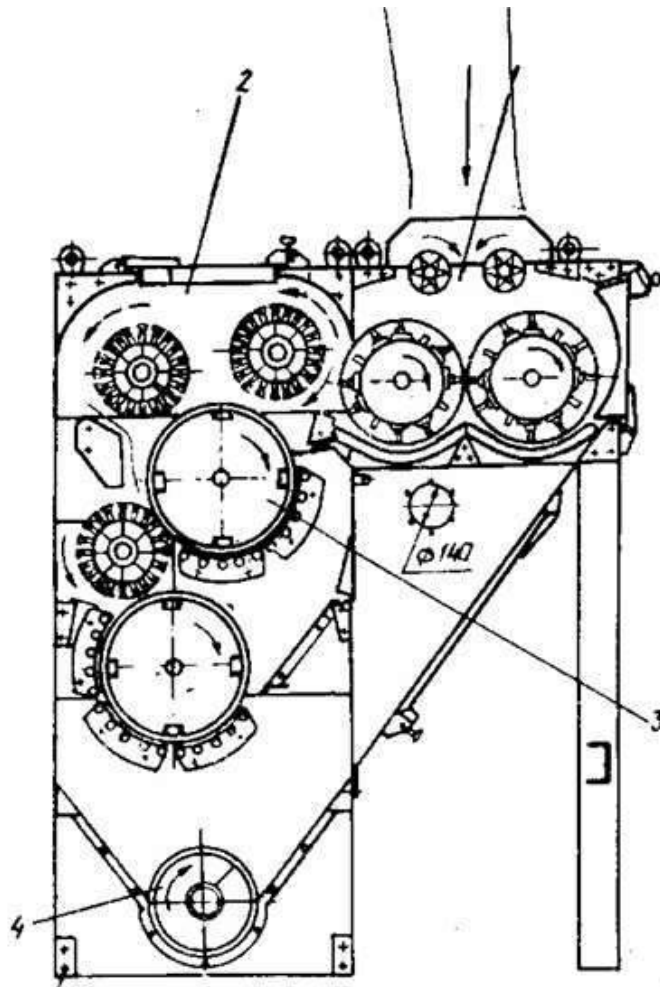
Figure 2. Working area of the UKHK cleaner with round grates.

Trapezoidal grates were also used in the cleaning section under the serrated cylinder of the OXP-3 cleaner (Fig. 1). When using trapezoidal grates in ChKh-3M cleaners, their working edge is 12 mm in size. Studies have shown that this design was ineffective. Round grates, the parameters of which are substantiated in [3], are more effective, but it should be noted that round grates used in cleaners are inferior to grates with a flat working edge in impact force, allow intensive release of trash impurities and lead to a decrease in the amount of free fibers. It is known that in OX-2 purifiers. ChKh-3M2 "Mekhnat", unit UKhK, in the purifier-regenerator PX, grates of a round profile are used. In fig. 2 shows the section for cleaning the cleaners ChKh-3M2, "Mekhnat" and the UKhK unit. In our opinion, grates of circular cross-section do not allow an increase in the cleaning effect without additional constructive solutions. One of these ways is to increase the degree of mobility of round grates.

Recently, cotton cleaning units UHK have

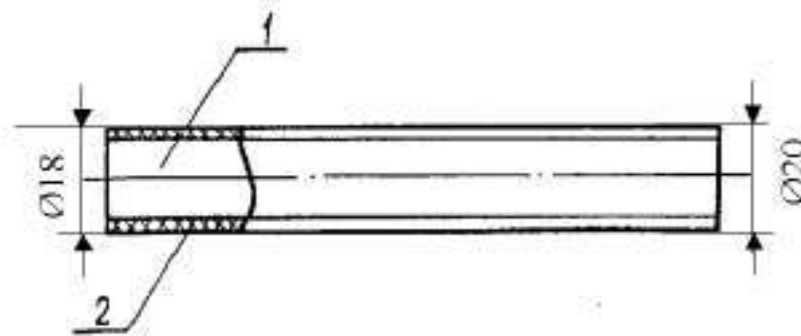
found widespread introduction in production [4]. The UKHK unit sequentially includes sections for cleaning raw cotton from fine and coarse litter. In fig. 3 shows a schematic diagram of a cotton cleaning unit UKhK, which includes three sections for coarse cleaning of cotton. In all these three sections, there are two serrated drums 4 and grates 5 under them. The grates have a circular cross-section with an outer diameter of 20 mm. It should be noted that with an increase in the cleaning efficiency of each of the sections, it is possible to reduce the number of sections, thereby also the frequency of cleaning cotton [5]. The lower the frequency of cleaning, the less damage to the fiber and cotton seeds.

In [6] A. Djuraev et al. Proposed elastic grates (Fig. 4), which consist of a cylindrical rod with a diameter of 18 mm and a rubber tube mounted on it. During the operation of the purifier, rubber-coated grates absorb the impacts of the cotton fly on the grate, which reduces mechanical damage to the seeds and the escape of the fly into waste.



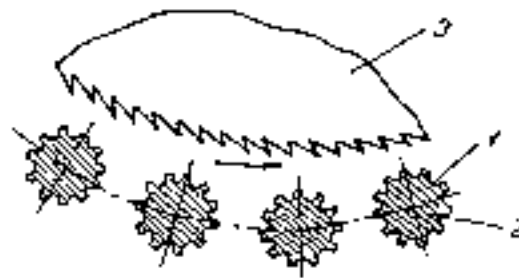
1-feeder, 2 - brush cylinder, 3-saw cylinder, 4 - auger for removing impurities.

**Figure 3. Scheme of the cotton cleaning unit UKHK**



1-round bar; 2-rubber tube.

**Figure 4. Round grate with rubber attachment**



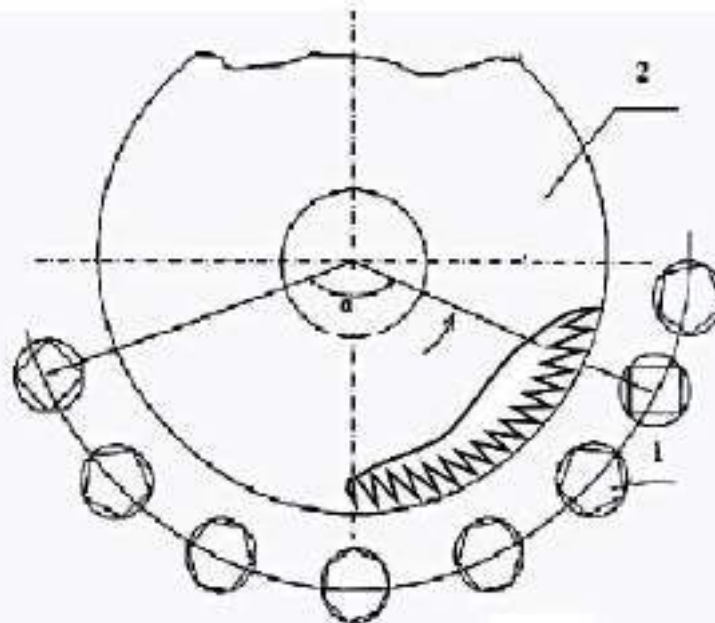
1-grate; 2-riffls (straight); 3-barreled cylinder

**Figure 5. Grate of the fiber material cleaner with corrugated grates**

In this case, the rubber sheath leads to a decrease in the shock impulse. In addition, the rubber coating, due to the increased friction between the cotton and the grates, inhibits the pulling of the cotton. Therefore, grates with an elastic coating are inactive and therefore have not found application in production. Also in the design of the grate (Fig. 5) having grates with grooves on the cylindrical surface [7] leads to damage to the fiber and seeds, the amount of free fiber increases.

In [8], a grate for a large litter cleaner is proposed, where under the serrated cylinder,

triangular grates with a circumferential diameter of 20 mm are installed, having forced rotations. The advantage of a grate with three-sided rotating grates (see Fig. 7) is that they allow better separation of trash impurities due to their edges, allowing some increase in the cleaning effect. When the depressions of the neighboring triangular grates coincide, the gap between the grates actually increases, which leads to the fallout of raw cotton volatiles through them. In addition, in the three faces of the grate, a significant amount of volatiles can fall out to waste, as well as an increase in damage to the fiber and cotton seeds.



1-grate, 2-working cylinder.

**Figure 6. Lattice grate with multifaceted grates.**

In a grate, where grates of multifaceted shape are installed between adjacent round grates [9], which also have forced rotations (Fig. 8). During the operation of the cleaner, the grate with forced rotation, to some extent, shakes the cotton, and

therefore there is some additional effect of cleaning the cotton. But, in this design, volatiles drop out to waste and to some extent increases the mechanical damage to the fiber and seeds [10-12].

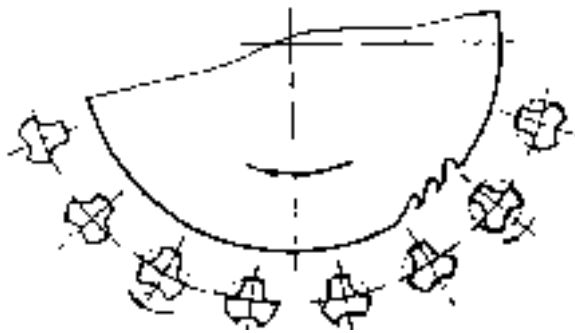


Fig. 7. Raw cotton grate with rotating triangular grates



1-saw cylinder; 2-round fixed grates; 3-rotating multifaceted grate.  
Fig. 8. Raw cotton grate with rotating multifaceted grates

In this case, the radius of installation of the grate relative to the axis of rotation of the cylinder and the pitch between them will be different, which correspond to the values of the corresponding diameters of the grate. Insufficient is the large waste of volatiles.

## CONCLUSIONS

Based on the design of plastic grates on elastic supports. For the analysis of the designs of grates of cotton cleaners - raw from coarse litter, newer effective lightweight schemes have been developed.

## REFERENCES

1. Murodov O. J. *The Development to designs and parameter vibratory plastic kolosniks defogger of the pat from large litter. Dissertation of Doctor of Philosophy (PhD) in Engineering Science. Tashkent - 2010, 120 pages.*
2. Jurayev A., and Rajabov O., *Experimental study of the interactional of multifaceted and cylindrical spiky cylinder in cotton cleaner from small waste, International Journal of Advanced Research in Science, Engineering and Technology. Vol. 6, Issue 3, (2019), pp. 8376-8381.*
3. Mavlyanov Aybek Palvanbaevich, Rajabov Ozod Isroilovich and Yakubova Aziza Vakil qizi, *Study of the influence of the parameters of the plastic grate on elastic supports with nonlinear stiffness on the oscillation frequency, International scientific and practical conference "Innovative ideas of modern youth in science", (2019), USA. P. 152-154.*
4. Z. Shodiyev, A. Shomurodov and O. Rajabov. *The results of the experimental nature of the vibrations of the grid cotton cleaner, IOP Conference Series: Materials Science and Engineering, 2020, 883 012169 <https://doi.org/10.1088/1757-899X/883/1/012169>*
5. Rajabov Ozod Isroilovich, *The influence of the mode of movement of the pieces cotton when interacting with a cotton grid, International Journal of Advanced Research in Science, Engineering and Technology (India). Vol. 6, Issue 3, (2019), pp. 8455-8381.*
6. Juraev Anvar and Rajabov Ozod, *Analysis of the interaction of Fibrous Material with a Multifaceted Grid of the cleaner, International Journal of Recent Technology and Engineering, vol. 8, No 1, (2019), pp. 2661-2666.*
7. O. I. Rajabov, A. S. Abrorov, N. I. Mirzaqulova, G. B. Zaripov, Kh. S. Ziyodullaev, *An experimental study of the location of the grid bars cells installed under spiked cylinders in a cotton cleaner from small waste, IOP Conference Series: Materials Science and Engineering, (2020), 734(1) 012073.*
8. Anvar Djuraev and Ozod Isroilovich Rajabov, *Substantiation of the main parameters of the cylinder with multifaceted spiked of the cotton cleaner from small waste, International scientific and practical conference Innovative ideas of modern youth in science, (2019), USA. P. 149-151.*
9. Ozod Rajabov, Ziyodullo Shodiyev, Ikrom Inoyatov, Mastura Gapparova. *Analysis of the Technological Process of Cleaning Raw Cotton from Small Trash, International Journal of Emerging Trends in Engineering Research, Volume 8. No. 9, September 2020, pp. 6022-6029.*
10. O.I. Rajabov, F.A.Fazliddin, M. H. Gapparova and J. Shakhrillo, *The influence of the location of the cells on the allocation of weed impurities for cleaning raw cotton from fine waste, IOP Conference Series: Materials Science and Engineering, (2020), 734(1) 012073.*
11. Rajabov O, Fazliddin K, and Salimov Sh., *Substantiation of Parameters of the Fibrous Material Cleaning Zone, International Journal of Engineering and Advanced Technology, vol. 9, No 3, (2020), pp. 1052-1057.*
12. Ozod Rajabov and Ziyodullo Shodiyev, *Analysis of Small Fluctuations of a Multifaceted Mesh under the Influence of Technological Load from the Cleaned Cotton - Raw, International Journal of Advanced Research in Science, Engineering and Technology, Vol. 6, Issue 10, (2019), pp. 11396-11399.*



## MICROSPONGES - A NOVEL DRUG DELIVERY SYSTEM

Mr. Pravin Tryambak Netkar<sup>1</sup>, Miss. Kaveri Wagh<sup>2</sup>,  
Mr. Shivam Ravindra Patil<sup>3</sup>, Mr. Utkarsh Prakash Metha<sup>4</sup>  
Miss. Harshali Ravindra Thakare<sup>5</sup>  
Miss. Fayza Qureishi<sup>6</sup>, Miss. Shraddha Ravindra Chavan<sup>7</sup>

<sup>1</sup>M. Pharm, Assistant Professor, Department of Pharmaceutics, Maharashtra, India

<sup>2</sup>M. Pharm, Assistant Professor, Department of Pharmaceutics, Maharashtra, India

<sup>3</sup>Student of Third year B Pharmacy, Maharashtra, India

<sup>4</sup>Student of Final year B Pharmacy, Maharashtra, India

<sup>5</sup>Student of Final year B. Pharmacy, Maharashtra, India

<sup>6</sup>Student of Final year B Pharmacy, Maharashtra, India

<sup>7</sup>Student of final year B Pharmacy, Maharashtra, India

---

### ABSTRACT

*Micro sponges are polymeric delivery systems composed of porous microspheres. They are tiny sponge-like spherical particles with a large porous surface. Moreover, they may enhance stability, reduce side effects and modify drug release favourably. Micro sponge technology has many favourable characteristics, which make it a versatile drug delivery vehicle. Micro sponge Systems are based on microscopic, polymer-based microspheres that can suspend or entrap a wide variety of substances, and can then be incorporated into a formulated product such as a gel, cream, liquid or powder. The outer surface is typically porous, allowing a sustained flow of substances out of the sphere. Micro sponges are porous, polymeric microspheres that are used mostly for topical use and have recently been used for oral administration. Micro sponges are designed to deliver a pharmaceutical active ingredient efficiently at the minimum dose and also to enhance stability, reduce side effects, and modify drug release.*

**KEYWORDS:** *Micro sponges, transdermal delivery, controlled release, topical, effective delivery.*

---

### INTRODUCTION

A Micro sponge drug delivery system (MDDS) is a patented, highly cross-linked, porous, polymeric microspheres polymeric system (10-25  $\mu$ ) consisting of porous microspheres particles consisting of a myriad of

inter connecting voids within non-collapsible structures with a large porous surface that can entrap wide range of actives (cosmetics, over-the-counter (OTC) skin care, sunscreens and prescription products) and then release them onto the skin over a time and in response



to trigger. A typical 25 $\mu$ m sphere can have up to 250000 pores and an internal pore structure equivalent to 10ft in length providing a total pore volume of about 1ml/g [1]. Micro sponge does not pass through the skin (capable of holding four times their weight in skin secretions). Rather, they collect in the tiny nooks and crannies of skin and slowly release the entrapped drug, as the skin needs it. The micro sponge system can prevent excessive accumulation of ingredients within the epidermis and the dermis. These products are typically presented to the consumer in conventional forms like creams, gels or lotions and they contain relatively high concentration of active ingredients. Micro sponges are polymeric delivery systems consisting of porous microspheres that can entrap a wide range of active ingredients such as emollients, fragrances, essential oils, sunscreens, and

anti-infective, anti-fungal, and anti-inflammatory agents. The MDS has advantages over other technologies like microencapsulation and liposomes. Microcapsules cannot usually control the release rate of actives. Once the wall is ruptured the actives contained within microcapsules will be released. Liposome suffer from lower payload, difficult formulation, limited chemical stability and microbial instability. (14)

Micro sponge Delivery System (MDS) technology has been introduced in topical drug products to facilitate the controlled release of active drug into the skin in order to reduce the systemic exposure and minimize local cutaneous reactions to active drugs. Micro sponges are designed to deliver a pharmaceutically active ingredient efficiently at minimum dose and also to enhance stability, reduce side effects, and modify drug release profiles. (6)

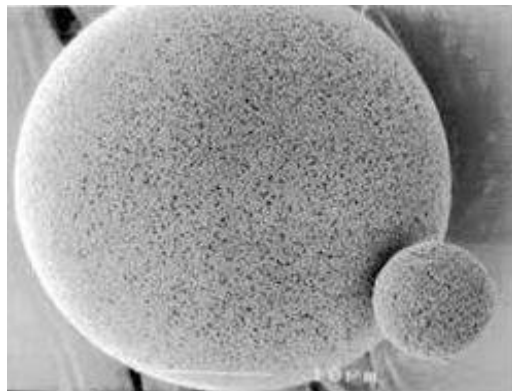


Fig 1: Ideal structure of Micro sponge (12)

### History of Micro Sponges

The micro sponge technology was developed by Won in 1987 and the original patents were assigned to Advanced Polymer Systems, Inc. (Redwood City, California, US). This Company developed a large number of variations of the procedures and those are applied to the cosmetic as well as over-the-counter (OTC) and prescription pharmaceutical products. At the current time, this interesting technology has been licensed to Cardinal Health, Inc., for use in topical products to facilitate the controlled release of active drug into the skin in order to reduce systemic exposure and minimize local cutaneous reactions to active drugs. (11)

### Properties of the Actives for the Entrapment into Micro sponges

Active ingredients that are entrapped in

micro sponges can then be incorporated into many products such as creams, gels, powders, lotions and soaps. Certain considerations are taken into account while, formulating the vehicle in order to achieve desired product characteristics:

- It should be either fully miscible in a monomer or capable of being made miscible by the addition of a small amount of a water-immiscible solvent.
- □It should be inert to monomers and should not increase the viscosity of the mixture during formulation.
- It should be stable when in contact with the polymerization catalyst and under conditions of polymerization.
- The spherical structure of the micro sponges should not collapse.
- Not more than 10% of the active ingredients must be incorporated into the vehicle in order to avoid

cosmetic problems.

□ Payload and polymer design of the micro sponges for the active must be optimized for required release rate for given period of time (3)

### Potential Advantages of the Microsponge Drug Delivery System

Microcapsules cannot usually control the release rate of the active pharmaceutical ingredients (API). Once the wall is ruptured the API contained within the microcapsules will be released. Can the MDS can do it, is the question.

Liposomes suffer from a lower pay load, difficult formulation, limited chemical stability, and microbial

instability. Do the MDS have a wide range of chemical stability and are they easy to formulate?

□ They have stability over a pH range of 1 – 11.

Micro sponges have stability up to temperature 130°C.

Micro sponge having Pay load is up to 50 – 60%.

□ They have free flowing and cost effective.

Micro sponges are microscopic spheres capable of absorbing skin secretions, therefore, reducing oiliness and shine from the skin. (4)

### Advantages of micro sponge technology

The advantages of MSP technology were pictorially represented in fig.



Fig. 2: Advantages of micro sponge technology (11)

### MSPS HAVE SEVERAL ADVANTAGES OVER OTHER PREPARATIONS AVAILABLE IN THE MARKET:

#### Advantages over Conventional Formulations

Conventional formulations of topical drugs are intended to work on the outer layers of the skin. Such products release their active ingredients upon application, producing a highly concentrated layer of active ingredient that is rapidly absorbed. When compared to the conventional system, Micro sponge systems can prevent excessive accumulation of ingredient within the epidermis and the dermis significantly reducing the irritation of effective drugs without affecting their efficacy.

#### Advantages Over Microencapsulation and Liposomes

Microcapsules cannot usually control the

release rate of actives. Once the wall is ruptured, the actives contained within microcapsules will be released. Liposomes suffer from lower payload, difficulty in formulation, limited chemical and microbial stability, whereas micro sponge system in contrast to the above system has several advantages like stable over a pH range of 1-11 and up to temperature of 130 °C, have higher payload up to 50 to 60 %, with average pore size of 0.25 µm where bacteria cannot penetrate.

#### Advantages over Ointments

Ointments are often unappealing, greasy and sticky that results in lack of patient compliance. These vehicles require a high concentration of active agents for effective therapy, which results in allergic reactions in significant users. Other drawbacks of topical formulations are uncontrolled evaporation of active ingredient and unpleasant odour. MSP systems

maximize the amount of time that an active ingredient is present either on skin surface or within the epidermis, while minimizing its transdermal penetration into the body (11).

### Limitations

1. Use of organic solvents as pyrogen, pose an environmental hazard which may be highly inflammable.

2. In case of the Bottom-Up approach traces of residual monomers have been observed, which may be toxic and hazardous to health.
3. While the limitations seem to be serious, they can be easily overcome by using proper quality control measures coupled with optimization and standardization of procedures e. g., Post-manufacture washing (11)

### Release Mechanism

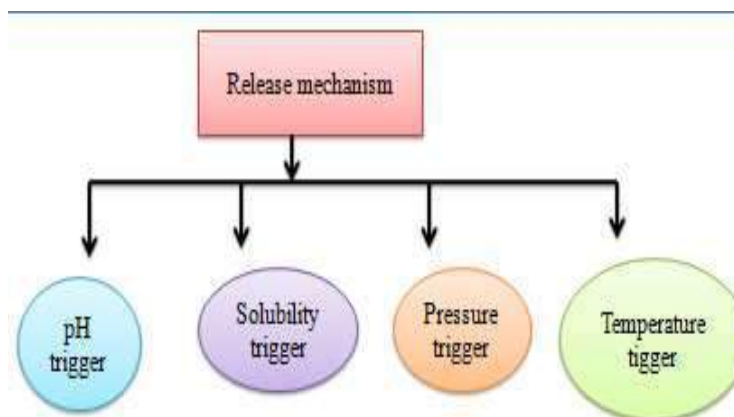


Figure 3: Programmable release from micro sponges (1)

### Pressure Triggered Systems

Micro sponge system releases the entrapped material when pressurized/rubbed; the amount released depends upon special characteristics of the sponge. The micro sponge best suited for a given application may be optimized by varying the type of material and different process variables.

### Temperature Triggered Systems

Some active ingredients loaded in micro sponge can be too viscous at room temperature to flow spontaneously into the skin. The flow rate can be increased by increasing the skin temperature and hence release. So, it is possible to regulate the release of substances from the micro sponge by modulation of temperature.

### pH Triggered Systems

Triggering the pH-based release of the active can be achieved by modifying the coating on the micro sponge. This has many applications in drug delivery.

### Solubility Triggered System:

Micro sponge loaded with water-soluble ingredients will release the ingredient in the presence of

water. The release rate of active ingredients can be triggered in the presence of aqueous medium. This release may be achieved based on the ability of the external medium to dissolve the active, the concentration gradient or the capability to swell the microspore network

### Micro Sponge Delivery System: Preparation Methods

A particular encapsulation method is selected on the basis of solubility properties of the drug and polymer **have** reported the preparation of micro sponge drug delivery system can be carried out using two methods: first method is liquid-liquid suspension polymerization and another is quasi emulsion solvent diffusion techniques. These methods are based on physical as well as chemical properties of loaded drug. If the loaded drug is usually an inert non-polar material, will generate the pervious structure known as "porogen".

Porogen drug is uncompleted to hinder the polymerization and to become it activated have been found out that other than above methods, lyophilization, water in oil in water (w/o/w) emulsion solvent diffusion and oil in oil (o/o) emulsion solvent

diffusion

### A. Liquid-Liquid Suspension Polymerization

1) Micro sponges are formulated by suspension polymerization method based on free radical

suspension polymerization technique shown in Figure 4  
2) In this method, the process was takes place in three naked round bottom flask with stirrer, connected with water condenser and thermometer is used to determine the temperature.

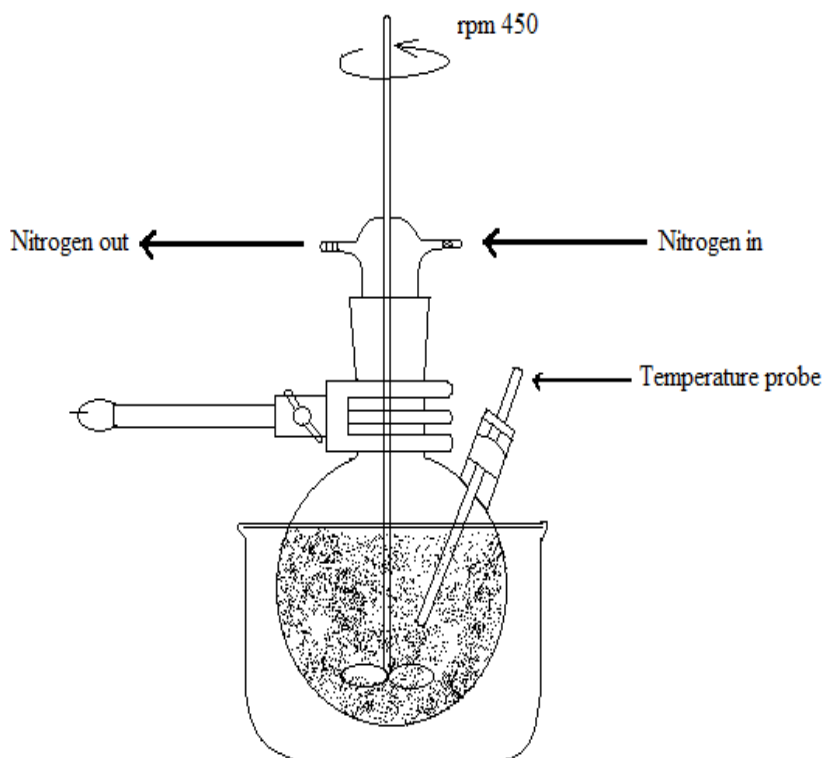


Fig. 4: Reaction vessel for micro sponge preparation by liquid-liquid suspension polymerization (13)

### B. Quasi-Emulsion Solvent Diffusion

1) This is the widely used technique of micro sponge preparation.  
2) Micro sponge was also prepared by second technique i.e., Quasi-emulsion solvent diffusion technique.

3) In this technique, the inner phase containing Eudragit polymer i.e., Eudragit RS 100 were dissolved in ethanol.  
4) After preparation of internal phase, the drug is added slowly into solution and then it dissolved under ultrasonication at temperature 35oC.

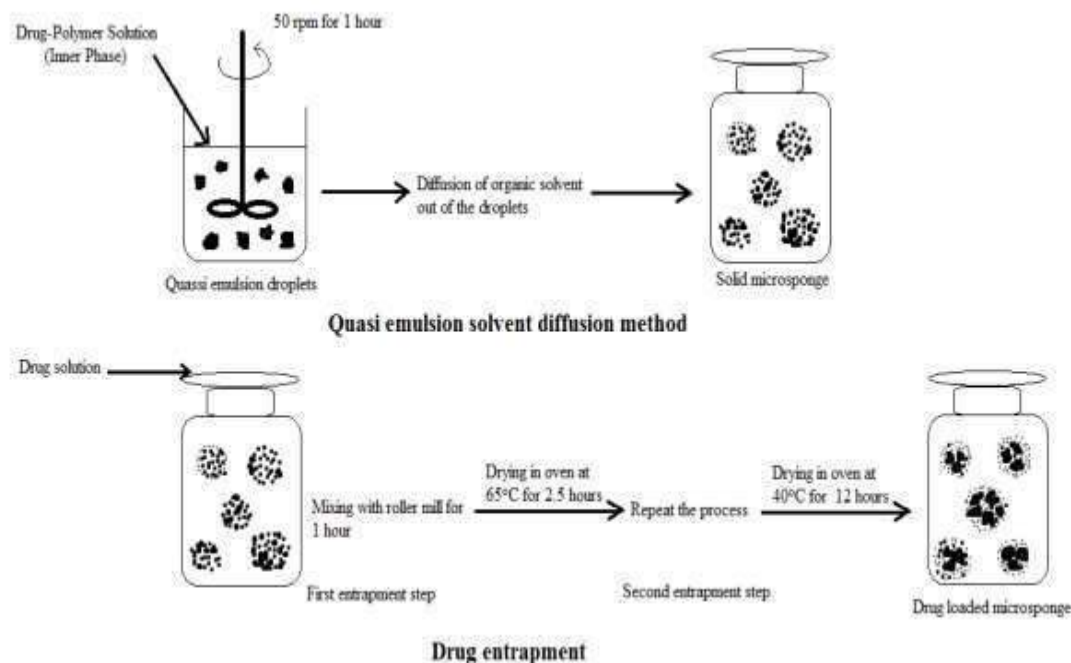


Fig. 5: Preparation of micro sponges by quasi emulsion solvent diffusion( 13)

### C. Lyophilization

Lyophilization is novel technique was prepared by gelation technique used for converting the microspheres to porous microspheres. In this technology, the microparticles were incubated in the Chitosan HCl solution and lyophilized. Rapid elimination of solvent leads to formation of pores in the microspheres. This method is quick and rapid. But due to rapid elimination of solvent, there are broken or shrunken microparticles are produced. This is the disadvantage of lyophilization method.<sup>13</sup>

### D. Water in oil in water (w/o/w) emulsion solvent diffusion

Another novel technique named w/o/w emulsion solvent diffusion was developed to prepare biodegradable porous microparticles. In this method, an internal water phase was dispersed in organic polymeric solution. The internal phase consists of an emulsifying agent such as span, stearyl amine and polyethyleneimine. After that, this w/o emulsion was again dispersed in external aqueous phase which contain PVA to form a double emulsion. The advantage of this method is the entrapment of both water soluble and water insoluble drugs.<sup>13</sup>

### HYPOTHETICAL MECHANISM OF ACTION

#### In Topical Formulations

The active ingredient is added to the vehicle in an entrapped form. As the micro sponge particles have an open structure (they do not have a continuous membrane surrounding them), the active is free to move in and out from the particles and into the vehicle until equilibrium is reached. Once the finished product is applied to the skin, the active that is already in the vehicle will be absorbed into the skin, depleting the vehicle, which will become unsaturated, therefore, disturbing the equilibrium. This will start a flow of the active from the MSP particle into the vehicle and from it to the skin, until the vehicle is either dried or absorbed. The MSP particles retained on the surface of the stratum corneum will continue to gradually release the active to the skin, providing prolonged release over time was shown in fig. 6. If the active is too soluble in the desired vehicle during compounding of the finished product, it will not provide the desired benefits of gradual release. Instead, they will behave as if the active was added to the vehicle in a free form. Therefore, while formulating MSP entrapments, it is important to design a vehicle that has minimal solubilizing power for the actives.<sup>11</sup>





## In Oral Formulations

MSPs with <200  $\mu\text{m}$  may efficiently be taken up by the macrophages present in the colon, thus exhibiting effective localized drug action at the desired site. They can also increase the lag time for absorption of the drug as these get entrapped on the surface of the colon and thus have the potential for being developed as a colon-targeted drug delivery system (11)

## Characterization of Micro Sponges(6):

Various methods are used for the evaluation of the MDS. These are following-

### 1. Particle size determination

Particle size analysis of loaded and unloaded micro sponges can be performed by laser light diffractometry or any other suitable method. The values can be expressed for all formulations as mean size range.

### 2. Morphology and surface topography of micro sponges

For morphology and surface topography, prepared micro sponges can be coated with gold-palladium under an argon atmosphere at room temperature and then the surface morphology of the micro sponges can be studied by scanning electron microscopy (SEM). SEM of a fractured micro sponge particle can also be taken to illustrate its ultra structure.

### 3. Determination of loading efficiency and production yield

The loading efficiency (%) of the micro sponges can be calculated according to the following equation: Loading efficiency = (Actual Drug Content in Micro sponges / Theoretical Drug Content) X 100

The production yield of the microparticles can be determined by calculating accurately the initial weight of the raw materials and the last weight of the micro sponge obtained. Production Yield = (Practical mass of micro sponges / Theoretical mass (Polymer + drug) X 100.21

**4. Characterization of pore structure Pore volume and diameter:** These are vital in controlling the intensity and duration of effectiveness of the active ingredient. Pore diameter also affects the migration of active ingredients from micro sponges into the vehicle in which the material is dispersed. Mercury intrusion porosimeter can be employed to study effect of pore diameter and volume with rate of drug release from micro sponges.

**5. Determination of true density:** The true density of microparticles is measured using an ultra-pycnometer under helium gas and is calculated from a mean of repeated determinations. 6.. Polymer/monomer composition Polymer composition of the MDS can affect partition coefficient of the

entrapped drug between the vehicle and the micro sponge system and hence have direct influence on the release rate of entrapped drug. Release of drug from Micro sponge systems of different polymer compositions can be studied by plotting cumulative % drug release against time.

### 6. Resiliency (viscoelastic properties)

Resiliency (viscoelastic properties) of micro sponges can be modified to produce beads that is softer or firmer according to the needs of the final formulation. Increased cross-linking tends to slow down the rate of release.

7. Dissolution studies Dissolution profile of micro sponges can be studied by use of dissolution apparatus USP XXIII with a modified basket consist of 5 $\mu\text{m}$  stainless steel mesh. The speed of the rotation is 150 rpm. The dissolution medium is selected while considering solubility of actives to ensure sink conditions. Samples from the dissolution medium can be analyzed by suitable analytical method at various intervals.

8.. Drug release from the semi solid dosage forms and drug deposition studies

Drug release from the semi solid dosage forms are performed by the Franz- type static diffusion cells. In this epidermal side of the skin was exposed to ambient condition. While dermal side was kept facing the receptor solution. Receptor compartment containing 20 mL phosphate buffer pH 5.8 was thermo stated at  $32 \pm 0.5^\circ\text{C}$  and stirred at 600 rpm. Skin was saturated with diffusion medium for 1 h before the application of sample. A 200-mg of sample was applied on the donor compartment. For determination of drug deposited in the skin, the diffusion cell was dismantled after a period of 4, 8, 16, and 24 h. The skin was carefully removed, and drug present on the skin surface was cleaned with distilled water.

9. Compatibility studies Compatibility of drug with reaction adjuncts can be studied by thin layer chromatography (TLC) and Fourier Transform Infra-red spectroscopy (FT-IR). Effect of polymerization on crystallinity of the drug can be studied by powder X-ray diffraction (XRD) and Differential Scanning Colorimetry (DSC).

10. In-vitro diffusion studies The in vitro diffusion studies of prepared micro sponge gel were carried out in Keshary-Chien diffusion cell using through a cellophane membrane. 100 ml of phosphate buffer was used as receptor compartment, and then 500 mg of gel containing 10 mg of drug was spread uniformly on the membrane. The donor compartment was kept in contact with a receptor compartment and the temperature was maintained at  $37 \pm 0.50^\circ\text{C}$ . The solution on the receptor



side were stirred by externally driven Teflon coated magnetic bars at predetermined time intervals, pipette out 5 ml of solution from the receptor compartment and immediately replaced with the fresh 5 ml phosphate buffer. The drug concentration on the receptor fluid was determined spectrophotometrically against appropriate blank. The experiment was carried out in triplicate.

### SAFETY CONSIDERATION

Safety studies of micro sponges can be established by:

- Irritation studies in rabbits
- Skin irritation studies in rabbits
- Mutagenicity in bacteria
- Oral toxicity studies in rats
- Allergenicity in guinea pigs.

### FUTURE EXPECTANCY

Micro sponge is the present-day novel technology, which is the mostly developed for the topical delivery system and recently for oral administration. It provides various kinds of advantages. Micro sponges are carefully designed pharmaceutical active ingredient that deliver the drug effectively at the target site with the minimum dose and also to enhance stability, reduce side effects and control drug release. The real face off in the future is the development of the delivery system for the oral peptide delivery by altering the ratio of polymers. Micro sponges will be an excellent drug delivery system. Micro sponges drug delivery system that can accurately control the release rates to the specific sites of the body will be sought in great detail in the years to come that have an immense on the health care system and. Some micro sponge related products are already approved; several products are currently under development and clinical assessment. 1

### Applications (3)

Micro sponges are used mostly for topical and recently for oral administration as well as biopharmaceutical delivery. It offers the formulator a range of alternatives to develop drug and cosmetic products. These are developed to deliver an active ingredient efficiently at the low dose and also to enhance stability, reduce side effects and modify drug release

#### The Micro sponge for Oral Delivery

A Micro sponge system offers the potential to hold active ingredients in a protected environment and provide controlled delivery of oral medication to the lower gastrointestinal (GI) tract, where it will be released upon

exposure to specific enzymes in the colon. This approach if successful should open up entirely new opportunities for MDS. In oral applications, the micro sponge system has been shown to increase the rate of solubilization of poorly water-soluble drugs by entrapping such

drugs in the micro sponge system's pores. Because these pores are very small, the drug is in effect reduced to microscopic particles and

the significantly increased surface area thus greatly increases the rate of solubilization. An added benefit is that the time it takes the micro sponge system to traverse the small and large intestine is significantly increased thus maximizing the amount of drug that is absorbed

### Micro Sponge for Topical Delivery

Microphonic Delivery of Fluconazole for Benzoyl peroxide (BPO) is mainly used in the treatment of mild to moderate acne and athlete's foot and the most common side effect associated with BPO is skin irritation and it has been shown that controlled release of BPO from a delivery system to the skin could lessen the side effect while reducing percutaneous absorption. Topical delivery system with reduced irritancy was successfully developed studied factors affecting the morphology of benzoyl peroxide (BPO) micro sponges. It has been revealed that encapsulation and controlled release of BPO can lessen the side effect while, when administered to the skin it also reduces percutaneous absorption. The goal of the study was to design and formulate a suitable encapsulated form of BPO using micro sponge technology and investigate the parameters affecting the morphology and other characteristics of the resulting products with the help of scanning electron microscopy (SEM). Benzoyl peroxide particles were prepared by an emulsion solvent diffusion method by including an organic internal phase containing benzoyl peroxide, dichloromethane and ethyl cellulose into a stirred aqueous phase containing polyvinyl alcohol (PVA). Different concentrations of BPO micro sponges were incorporated in lotion formulations and the drug release from these formulations were studied. The SEM micrographs of the BPO micro sponges used for the measurement of their size and showed that they were porous and spherical. Results showed that the morphology and particle size of micro sponges were affected by drug: polymer ratio, amount of emulsifier used and stirring rate. The results obtained also showed that with increase in the ratio of drug: polymer resulted in a reduction in the rate of release of BPO from the micro sponges. The release data showed that the



highest and the lowest release rates were obtained from lotions containing plain BPO particles and BPO micro sponges with the drug: polymer ratio (13:1) respectively. Kinetics studies showed that the release

data followed peppas model but diffusion was the main mechanism of drug release from BPO micro sponges.

**EXAMPLE OF MICROSPONGES DDS  
 TOLNAFTATE MICROSPONGES EMBEDDED BIOCOMPATIBLE GELS FOR CONTROLLED  
 AND EFFECTIVE ANTIDERMATOPHYTIC ACTIVITY. (9)  
 MARKETED FORMULATION**

**TABLE NO. 1 Applications of micro sponges (6)**

S. No.	Active agents	Applications
1	Sunscreens	Long lasting product efficacy, with improved protection against sunburns and sun related injuries even at elevated Concentration and with reduced irritancy and sensitization.
2	Anti-acne e.g., Benzoyl peroxide	Maintained efficacy with decreased skin irritation and sensitization.
3	Anti-inflammatory e.g., hydrocortisone	Long lasting activity with reduction of skin allergic response and dermatoses.
4	Anti-fungal	Sustained release of actives.
5	Anti-dandruffs e.g., zinc parathion, selenium sulfide	Reduced unpleasant odor with lowered irritation with extended safety and efficacy.
6	Antipruritic	Extended and improved activity
7	Skin depigmenting agents e.g., hydroquinone	Improved stabilization against oxidation with improved efficacy and aesthetic appeal.
8	Rubefaciants	Prolonged activity with reduced irritancy greasiness and odor.

**CONCLUSION**

MDS holds significant potential in both pharmaceutical as well as cosmetic industries because of its release technique is novel and its ease of administration with fewer side effects, more research works are carried out to optimize its efficacy for the therapy. It is a unique technology for the sustained release of topical agents which act locally. It is originally developed for topical delivery of drug like anti-acne, anti-inflammatory, anti-fungal, anti-dandruffs, antipruritic, and rubefaciants. Micro sponge's delivery system that can release its active ingredient on stimuli. Therefore, a micro sponge has got a lot of potential in drug delivery technology today.

**REFERENCE**

1. Jyoti and Kumar Sandeep, *Innovative and Novel Strategy: Micro sponges for Topical Drug Delivery, Journal of Drug Delivery and Therapeutics, 2018: 28-34.*
2. M.S. Charte, P.B. Ghanawat, A.S. Welahkiwar, J. Kumar R.D. Chakola, *Microsponges, A Novel Drug*

*Delivery System: A Review, International Journal of advances in Pharmaceutics 2013; 2(6).*

3. Dumbre K.A, Banerjee S.K, M.U. Gathave, Gaikwad D.D., *Microsponges : A Novel Drug Delivery System, Asian Journal of Pharmaceutical Research & Development, Vol-2(2) 2014, 65-74*
4. Gup Akashdeep, Dhyni Archana and Juyal Divya, *Microsponges : Iafen Gel for Topical Delivery : A Novel Approach, The Pharma Innovation Journal 2016;5(6):39-43.*
5. D'souza John I. and More Harinath N., *Topical Anti- Inflammatory Gels of Fluocinolone Acetonide Entrapped in Eudragit Based Microsponge Delivery System, Research Journal of Pharmacy and Technology, 2008; 1(4):502-506.* Mantry Shubhrajit, Bagchi Arnab, Das Sujit, Das Sudip,
6. Arijit gandhi, saugata jana, kalyan kumar sen, tailoring effect of microsponges for target drug delivery, *journal of scientific and innovative research 2013;2(6):1073-1082*
7. Kaity Santanu, Maiti Sabyasachi, Ghosh Ashoke Kumar, Pal Dilipkumar, Ghosh Animesh , Banerjee Subham, *Microsponge: A Novel Strategy For Drug*



- Delivery System, Journal of Advanced Pharmaceutical Technology and Research, 2010; 1:283-290. Microsponge as A Novel Strategy of Drug Delivery System,*
8. Vival Shaha, Hitesh Jain, Jetha Krishna, Pramit Patel, *Microsponges Drug Delivery: A Review I.J.R.P.S, Vol-1 2010, 212-218.*
  9. Prashant Pandey, Sashi Kiran Mishra & Pushpa Kumari, *Tolnaftate – Micro sponges Embedded Biocompatible Gels for Controlled And Effective & Anti-Dermatophytic Activity, International Research Journal of Pharmacy Pharma 2018; 9(8).*
  10. Vishal Yadav, Prakash Jadhav, Shailaja Dambe, Anjali Bothe, Prahalin Salunkhe, *Formulation & Evaluation of Microsponges gel for Topical Delivery of Anti-Fungal Drug, Vol-9, Issue 4, 2017.*
  11. Saripilli Rajeshwari, Vanapalli Swapna *Microsponges as a Neoteric Cornucopia for Drug Delivery System, Int. J. Curr. Pharm. Research Vol 11, Issue 3, 4-12.*
  12. Balamurugan K. Kshirasagar N. and Gowardhan P., 2019. *Microsponges: As a Drug Delivery System. J Pharm Innov., 2019,8(1):139-143.*
  13. *Microsponges : An Innovative and Novel Strategy for Drug Delivery System Buddhahushan V. Bansol et.al. International Journal of ChemTech Research Vol-2, 299-321, 2019.*
  14. Deepak Sharma et.al., *Recent Advancement: Microsponges DDS: A Review Pharmatutor. Universal Journal of pharmaceutical science and research, 2015; 1(1):32-38.*
  15. Kumar Jaya raja, Muralidharan Selvadurai and Parasuraman Subramani, *Evaluation of Antifungal Activity of Sustained Release Microsponge Enriched Fluconazole Gel for Penile Candidiasis in Male Rats, International Journal of PharmTechnique Research, 2014;6(6):1888-1897*
  16. Avhad Pawan S. and Patil Prashant B., *A New Era In Topical Formulations – Microsponge Drug Delivery System International Journal Of Pharmaceutical Science And Research, 2016; 7(7):2756-2761.*
  17. Muralidharan Selvadurai, Kumar Jaya raja, Ramasamy Sanggetha, *Microsponges Enriched Gel (MEGs): A Novel Strategy for Ophthalmic Drug Delivery System Containing Ketotifen, Journal of Pharmaceutical Science. & Research 2013; 5(4):97-102.*
  18. Pathan Adil, Sanghshetti, *Microsponge in Drug Delivery: A Review, International Journal of Parenteral and Dermatology, 2017; 1(1):32-35.*



# THE RISE OF OTT PLATFORM: CHANGING CONSUMER PREFERENCES

**Ms. Kaneenika Jain<sup>1</sup>**

<sup>1</sup>Assistant Professor, S.S. Jain Subodh Management Institute,

## ABSTRACT

*The internet has enormously changed the functioning of most of the industries. Entertainment industry has faced drastic changes in the operations due to the rising usage of internet among its target audience. The consumers are now well informed and acquainted with new technology and the emerging trends in the entertainment sector. This scenario is highly responsible for the growth of the OTT platforms all around the world. Even target audience in India is much familiar with the movies, shows, music and other genres offered by different OTT platforms. Netflix, Amazon Prime, Disney+ Hotstar, Zee5 etc. are becoming very popular video streaming platforms for salaried and youth market in India. The expansion of OTT industry has tuned out profitable to entertainment sector. This article draws attention to the rise of OTT, factors influencing its success and the major players catering the target audience etc.*

**KEYWORDS:** Entertainment, Media Industry, OTT, Streaming, Video

## INTRODUCTION

The digitalization of technology has contributed to the success of businesses to a great extent around the globe. The entertainment and media industry has witnessed an unparalleled growth in the past few decades. Now the consumers are not dependent on their television sets for entertainment. A new era of binge watching has gaining popularity now a day on OTT platforms. OTT, over the top, is a preferred choice for most of the consumers of media and entertainment industry. The use of smart phones, laptops, tablets and economic rates of internet packs are the key factors for the inclination towards OTT channels.

According to IBEF, The OTT sector in India witnessed a 30% rise in the number of paid subscribers, from 22.2 million to 29.0 million between March and July 2020, due to Covid 19 led Lockdown. As per a recent study, most Indian viewers prefer watching regional language content, especially in Hindi, on the OTT platforms. Hindi language content accounted for >50% of the overall streaming in April-July 2020. Overall, the top five metro cities accounted for 46% of the total OTT video platform users, while Tier I cities accounted for another 35% users in July 2020.

According to Redseer, the online content consumption in India grew 35% in April 2020 compared to January 2020. It further stated that short-form video content consumption recorded the most significant jump during the lockdown.

According to the Boston Consulting Group (BCG) and CII report, the average digital video consumption in India witnessed a 2X growth in the last two years. The report also mentioned that on average time spent in video consumption by Indians increased from 11 minutes to 24 minutes per day (as of November 2019).

The PwC Global Entertainment & Media outlook: 2020-2024 report revealed that OTT video content growth is happening from inside and outside the home due to proliferation of Smartphone devices and internet connected Television sets. Subscription VOD will be the prime driver of revenue, increasing at a 30.7 percent CAGR from US\$708 million in 2019 to US\$2.7 billion in 2024. The report said that India is the fastest-growing OTT market at 28.6 percent CAGR; to become the sixth-largest market in 2024. India's OTT market will overtake South Korea, Germany and Australia and become the sixth-largest market in 2024.





India is now the sixth-largest Internet ad market in the Asia Pacific, having surpassed Taiwan in 2019.

Inc42.com indicated that India currently has 95 OTT platforms across video, music, podcast and audio streaming category. The average time spent by Indian users on OTT platforms has increased by 30-60% since early March 2020. Over the top (OTT) streaming platforms such as Disney+ Hotstar, ZEE5, Netflix, Amazon Prime Video, along with local players such as BIGFlix, Alt Balaji, Voot, Spuul, Eros Now, SonyLIV, Sun NXT, Hoichoi, Ullu, MXPlayer among others have redefined the way Indian audience consume content. In line with global trends, the Indian consumer is increasingly consuming the content on digital platforms. This trend is observed for all type of content including news (text), music (audio), or video. Increasing internet penetration and mobile device proliferation and convenience of consuming the content anytime, anywhere are the key drivers for this trend.

The Indian OTT Video Services Market is projected to grow at an aggressive CAGR of more than 30% during 2021 - 2025 due to the growing number of smart phones users, higher proliferation of smart devices, cheaper internet plans, consumer preference for good quality content, increasing urban population and rising innovation in OTT platforms in the country's OTT video services market.

Rising disposable income and increasing demand for OTT video services from young population are other factors contributing to growth in OTT video services market in India. Moreover, changing lifestyle of consumers and COVID-19 restrictions are also expected to boost OTT Video Services market in India.

## OTT MODELS

The OTT market is segmented into advertising video on demand (AVOD), subscription video on demand (SVOD) and freemium & transactional video on demand (TVOD).

### a) Advertising Video on Demand (AVOD):

These models use advertisements in between the content watching for monetizing the traffic on a particular content. YouTube is one of the popular examples of AVOD.

### b) Subscription Video on Demand (SVOD):

The OTT platform offers a bunch of subscription plans for different time periods to the audience. The consumers may pay the subscription charges and enjoy the content available on the platform from any electronic device. Amazon Prime, Netflix etc are popular SVOD platforms.

### c) Freemium Model:

Freemium OTT platforms are combination of both AVOD and SVOD. Some of the contents for watching are available for free while to watch exclusive contents consumers need to pay subscription charges. Some of the well known freemium platforms are ErosNow, Disney+ Hotstar, SonyLiv etc.

## FACTORS INFLUENCING GROWTH OF OTT

The awareness and use of technology has tremendously influenced the growth of sectors like e-commerce, digital marketing, online education, on demand entertainment etc. Some of the important factors that have contributed to the rise in the OTT platforms can be:

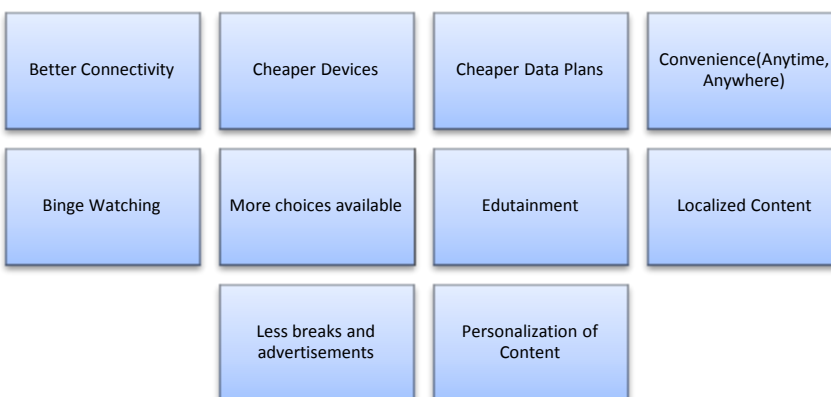


Figure 1: Drivers for Growth of OTT



## MAJOR OTT PLAYERS IN INDIA

There are various OTT platforms are offering their services in Indian market. Some of the important ones are discussed here.

### 1. Disney+ Hotstar

Disney+ Hotstar is arguably the most popular OTT platform in India. The streaming service, now owned by Walt Disney, has a vast catalogue of content that is divided across movies, TV shows, web series, sports, kids content, and news. With Disney owning the service, you also get access to Marvel, Star Wars, and tons of Disney animated movies and shows. Disney+ Hotstar is compatible with both iOS and Android devices as well as PCs and smart TV. To stream content from this OTT platform, you need to subscribe to one of its plans. Disney+ Hotstar subscription is available with two plans: VIP and Premium, which are priced starting at Rs 299.

### 2. Netflix

The American over-the-top content platform has delivered tons of exceptional and highly-streamed original shows and movies, such as Sacred Games, The Queen's Gambit, Stranger Things, and so on. There are a variety of Netflix subscription plans, namely Mobile, Basic, Standard, and Premium, which starts at just Rs 199 a month. The Netflix plans in India differ in terms of resolution and number of simultaneous viewing, while the catalogue of the content remains the same.

### 3. Amazon Prime Video

The subscription to Amazon Prime Video is free with the e-commerce platform's Prime membership, which also includes free Amazon Prime Music subscription alongside unlimited free and quick delivery, exclusive deals and discounts, and access to e-books. The OTT platform Prime Videos is known in India for its original web series such as Mirzapur, The Family Man, Tandav, Paatal Lok, and One-Mic Stand, among others. It's also home to some critically-acclaimed international TV shows and movies, regional content, Bollywood, kids content, and iconic TV shows. Besides English, Prime Video is available in six other Indian languages at the moment. Amazon Prime membership costs Rs 129 a month and Rs 999 a year.

### 4. Zee5

Zee5 is another popular OTT platform in India. It's a home-grown video streaming service, owned by Essel Group, that offers a mix of originals, shows, music, and movies in 12 languages and has a bespoke catalogue of premium content for audiences across India. Zee5 also leverages its partnership with ALTBalaji whose originals, shows, and movies are available for free to ZEE5 subscribers. The streaming service subscription plans start for as low as Rs 99 a month. Recently the

most awaited movie 'Radhe' featuring Salman Khan released on Zee5 platform for audience.

### 5. Sony Liv

Sony Liv has over 18 years of content such as TMKOC and The Kapil Sharma Show from channels that are part of the Sony Entertainment Network, such as Sony TV, Sony SAB, Sony Ten, Sony Max, Sony Max 2, Sony Six, Sony Pix, and Sony Yay. You can also livestream WWE, European football, La Liga, Champions League, and other sporting events that are broadcasted live on Sony SIX, Sony TEN 1, Sony TEN 2, and Sony TEN 3 channels via the OTT platform in India. The Sony Liv app is also subscription-based, with its plans in India starting at just Rs 199 a month.

### 6. Voot

This major OTT platform in India is owned by Viacom18, which also runs several TV channels in the country such as Colors, and produces films. Voot brings all these programs under one roof, much like Sony Liv. You can stream all Viacom18 TV shows and movies via the platform's app and website at any time and from anywhere. Initially, Voot was a free-of-cost streaming service, but now the company has introduced plans at Rs 99 per month and at Rs 999 per year.

### 7. AltBalaji

AltBalaji has also carved out a niche for itself in the Indian OTT platform industry. The streaming service offers a number of original web series and movies, mostly 18+, in Hindi and a variety of regional languages such as Bengali, Hindi, Marathi, Punjabi, Tamil, and many more. AltBalaji subscription plans are as follows: Rs 100 for three months, Rs 180 for six months, and Rs 300 for a year.

### 8. JioCinema

JioCinema is a video-on-demand OTT service from Mukesh Ambani-promoted telco Jio. The platform is exclusive to Jio users only, with no additional charges. The catalogue of JioCinema content includes movies, TV shows, Jio exclusives, documentaries and trailers. Jio recently also partnered with Disney India to offer popular Disney movies like Toy Story 3, The Jungle Book, The Lion King, and more.

### 9. MX Player

MX Player has come a long way from being just a video player. It's now among the best OTT platforms in India. MX Player provides users with syndicated content along with its own originals. While the streaming service is completely free of cost, it does interrupt your experience by showing ads in between consuming content.

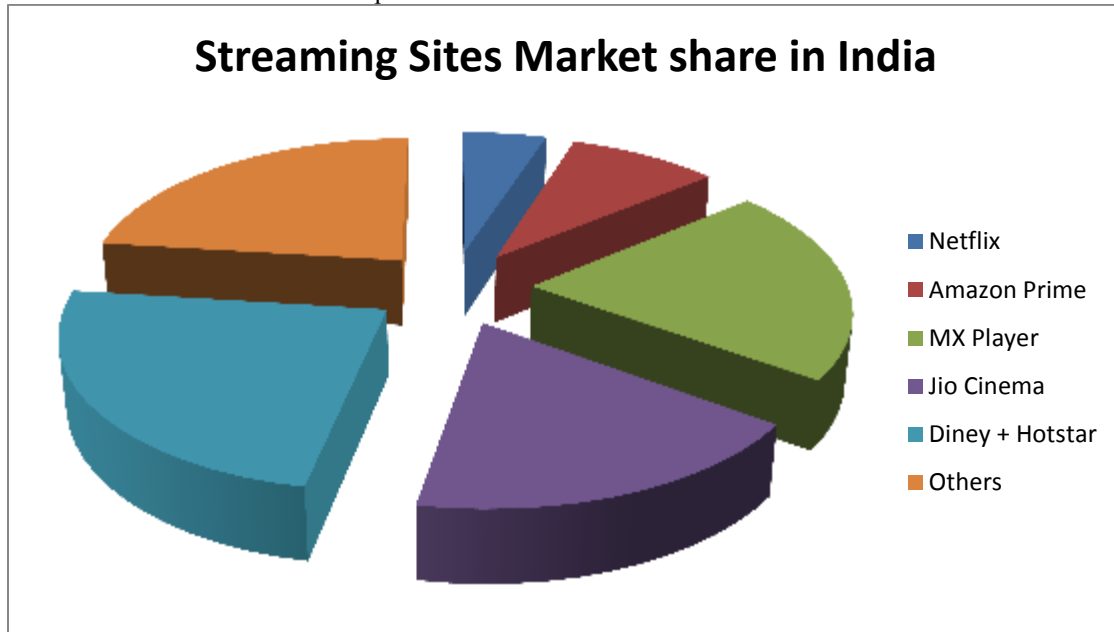
### 10. YouTube Premium

YouTube as a streaming device is very popular, but little would know that the platform has its original shows. These shows are exclusive with YouTube



Premium subscription plan, which is priced at Rs 129 per month and Rs 399 for three months. This is for a single user. There are also plans for a family with up to five members and students. The latter is priced at Rs 79

a month, while the family plan costs Rs 189 per month. Moreover, Premium customers do not have to watch any sort of ads and also get access to the YouTube Music service.



### IMPACT OF COVID-19 ON THE INDIAN OTT MARKET:

Amid the nationwide lockdown due to the ongoing corona-virus (COVID-19) pandemic, OTT platforms in the country have witnessed a substantial surge in terms of content consumption and subscriber count, and hence are striving to meet viewers' swelling appetite for entertainment. The average time spent by a subscriber on an OTT platform has increased from about 20 minutes to at least one hour during recent times. It is estimated that an user spent at least 32% more time watching original series on various OTT platforms during the March 20th 2020-April 3rd 2020 period as compared with the January 13th 2020-February 2nd 2020 period.

To meet the increasing demand and reduce internet congestion, OTT platforms including Hotstar, SonyLIV, ALTBalaji, Amazon Prime Video, Netflix and Zee5 have unanimously decided to cut down high definition picture quality (1080p & 720p) bitrate to standard definition picture quality (480p).

Impact of COVID-19 on market players:

- In April 2020, Indian OTT platform Zee5 reported that overall it witnessed a viewership of 437.4 Mn

during the lockdown period, starting from March 2020 till April 2020.

- In April 2020, ALTBalaji reported that the OTT platform is currently witnessing a considerable rise in digital subscriptions with an average of 17,000 subscriptions being added per day post the announcement of lockdown in the country, as against an average of 10,600 in March 2020 before the lockdown, which corresponds to a dramatic growth of roughly 60%

- As of April 2020, DAU of Amazon Prime Video in India increased by 83% since the country went under lockdown

- On March 20th 2020, MX Player reported to have witnessed a two-times increase in the time spent across content in various genres by Indian users, especially across MX Originals.

### CONCLUSION

With the boom in the technical specifications of smart-phones and rising usage of internet the entertainment industry is performing well with OTT services. The pandemic Covid 19 has contributed a large to the subscription of popular OTT series due to ample free time and need for edutainment and



entertainment during lockdown. As the shooting of TV serials and movies were stopped due to lockdown, the consumer shifted towards OTT and the demand offshoot with a high rate. Now consumers are more comfortable with OTT services owing to the convenience and variety available without advertisements. As the trends are observed, the market of OTT will grow rapidly in the coming years too. The companies will now face the changing preferences for OTT platforms instead of entertainment offline.

## REFERENCES

1. Rohit Jacob Jose. (2020). *Factors influencing the shift from traditional TV to OTT platforms in India. International Journal of Advanced Science and Technology*, 29(7s), 4044-4051. Retrieved from <http://sersc.org/journals/index.php/IJAST/article/view/22888>
2. Sundaravel, E. & N., Elangovan. (2020). *Emergence and future of Over-the-top (OTT) video services in India: An Analytical Research. International Journal of Business Management and Social Research*. 8. 489-499. 10.18801/ijbmsr.080220.50.
3. Dr. Sabyasachi Dasgupta and Dr. Priya Grover, *Understanding Adoption Factors of Over-the-Top Video Services among Millennial Consumers, International Journal of Computer Engineering and Technology*, 10(1), 2019, pp. 61-71.
4. *Digital Media: Rise of On-demand Content (2015)*, Report by Deloitte, [www.deloitte.com/in](http://www.deloitte.com/in)
5. *The Digital First Journey(2017)*, Report by KPMG, [www.KPMG.com/in](http://www.KPMG.com/in)
6. <https://brandequity.economictimes.indiatimes.com/news/media/india-is-the-fastest-growing-ott-market-at-28-6-percent-cagr-pwc-report/78804323>
7. Grewal D. and Levy M. (2017) *Marketing*, McGraw Hill Education, Chennai, fifth edition



# ELECTROMAGNETIC FIELD OF LOW FREQUENCY AND COMMUNICATION SYSTEMS IN MICROORGANISMS

**Bakhodir Mukhamadiev<sup>1</sup>, Shurangiz Kasimova<sup>2</sup>, Nodirabegim Kasimova<sup>3</sup>**

<sup>1</sup> Associate Professor, Department of Chemistry, Bukhara Engineering and Technology Institute, Bukhara, Uzbekistan

<sup>2</sup> Master's Degree Holder, Tashkent Pharmaceutical Institute, Tashkent, Uzbekistan

<sup>3</sup> Student, Bukhara State Medical Institute named after Abu Ali ibn Sino, Bukhara, Uzbekistan

## ABSTRACT

*The role of EMF in biological systems is considered in a large number of works performed by various foreign scientists. The energy imparted to the EMF system by the ELF field is much less than the energy of thermal movements. But no work discusses the issues of impulse exchange in biological systems, and first of all, between molecules of (flexible)  $\gamma$ -protein and membranes that act as a capacitor of electrical impulses. The purpose of the article is to fill this gap in science by discussing the literature data on the effect of ELF and ELF EMFs on biological systems, primarily, the protein envelope of the virus + the host cell membrane.*

**KEY WORDS:** communication, electrical impulses, cell, virus, bacteria, EMF, ELF, ELF.

## INTRODUCTION

At present, as a result of generalization of a large number of works, it is known that a constant magnetic field (PMF) can significantly change the rate and nature of the growth of microorganisms. Since they, like all other living microorganisms, in the process of life, receive, process and use information about the world around them, it is natural due to their high sensitivity to EMF, especially to ELF (ultra-low frequency) and ELF (extremely low frequency) EMF (1,2), the question arises about the presence of a communication channel in microorganisms due to various physical fields, which are otherwise called remote interaction. It is possible that the main role in this interaction belongs to ELF and ELF EMF. In this regard, it is necessary to consider the influence of these fields as a factor that is of the same importance in the life of bacteria as temperature, pressure, humidity, radiation, etc. the purpose of this work is to theoretically consider the processes of information exchange between cells and their surrounding compounds (environment) using weak electromagnetic waves.

The effect of weak EMF on microorganisms has the character (nature) of stress, as a result of which the number of colonies sharply decreases, but

after some time the number of microorganisms is restored. In addition, after a slight decrease in the number of microbes by 3-5 times in comparison with the control. This nature of population changes is well known in microbiology. Under the influence of a certain unfavorable factor, the number decreases, followed by adaptation of the surviving individuals to it, which is subsequently accompanied by their active reproduction, as a result of which the population size exceeds the optimal one, which causes a decrease in reproduction. The considered phenomena lead to decaying waves of population size in time. So, in the case of ELF EMF action, a stress response of microbes to the effect is observed. Consequently, there is now significant progress in understanding the influence of ELF EMF on physicochemical and biological systems. [3]

Currently, there are a number of hypotheses explaining the mechanism of ELF EMF action on the above systems. The most discussed in the scientific community among them are the following: cluster, NMR, EPR, stochastic resonance, cyclotron resonance, modulation of the velocity of individual particles and particle fluxes under the influence of ELF EMF. At first, the efforts of scientists were directed to the study of the influence of ELF EMF on chemical processes, then, consequently, it is capable





of influencing biological systems as well. chemical reactions underlie the growth and development of cells, transformation of energy into a form suitable for various biological processes, coding of genetic information, changes in membrane potential capable of transmitting electrical impulses over distances (communication). When an electric pulse passes through a liquid medium, convection flows can arise in it, which can lead to a redistribution of the substances contained in them, which can cause changes in electrochemical reactions occurring at the membrane-liquid interface. [4]

The energy of interaction of an ion in a solution with a weak electric potential is very small compared to thermal energy. EM P ELF can significantly affect  $n$  and orientation of the large asymmetric molecules having a dipole moment, which may affect the steric factor  $R$ . The molecules can be oriented in a magnetic field in a direction favorable to the reaction that increases or decreases the likelihood of a favorable impact, respectively. Under the influence of ELF EMF, magnetoanisotropic molecules and particles of a substance, which freely diffuse in a solution, can orient themselves in space. This orientation will occur when the number of monomers is of the order of  $n = 10^8 - 10^{16}$ , which significantly exceeds the number of amino acids of the protein coat of the virus and can correspond to the RNA molecule. However, the orientation of RNA in solution is primarily determined not by the entire molecule, but by the Coulomb stiffness segment, consisting of several hundred base pairs ( $n = 10^2$ ). The very low degree of orientation of the stiffness segments observed in the ELF EMF can lead to significant changes in the three-dimensional structure of RNA, thereby hindering the process of RNA replication. If molecules, due to intermolecular interactions, form cooperative regions with a preferred orientation of molecules, then these regions are often called domains. An external magnetic field is, in principle, capable of causing domain orientation in a macroscopic sample, which leads to a change in many characteristics of solutions. If the domain occupies a membrane area with linear dimensions of several microns, then the orientation effect can be significant. [5]

When studying the effect of ELF EMF on protein structures of SARS - virus, you must take into account the impact of the water environment in which due to the existence of spatially directed  $\gamma$ -links macromolecules acquire the necessary conformation and ability to perform its differential function. With a certain moistening of the protein, it becomes mobile (labile) due to the formation of a layer of bound water on its surface, which is fixed when the virus enters the host cell. By scattering  $\gamma$ - rays: when the critical values of

moisture sharply increase the rms amplitude of the oscillations nonhydrogen atoms, and also change the mechanical properties of the protein (allotropic change). When studying the mechanisms of action of ELF EMF, a dependence of a number of effects on changes in the properties of the aqueous phase was found. These data on the influence of ELF and ELF EMF allow us to consider the aquatic environment as one of the universal receptor systems in the process of intermolecular communication. Significant changes in the properties of solvents when a portion of water treated with ELF EMF is added to them, as well as a significant dependence of the manifestation of the effects of EMF on aqueous solutions on the concentration of substances reacting selectively, indicate a significant influence of the aqueous medium on magnetobiological effects, including those associated with communication phenomena. [6]

There is a large class of chemical reactions, the rate of which can be significantly influenced by EMF. These reactions are associated with the stage of interaction of paramagnetic particles. This pair can be in different electronic spin states, which determine different reactions of the system. According to the spin conservation law, a reaction product can be formed only through some channels ("spin ban"). The interaction of an external magnetic field with the spins of the reactants can lead to the opening of new or redistribution of old reaction channels, which, in the case of a short lifetime of a pair in comparison with its spin-lattice relaxation time, can change the rates of the forward and reverse reactions.

There are two possibilities energy conversion of the magnetic field in the orbital energy of the degrees of freedom of the particles, which in the end lead controlled biochemical (immunochemical) reaction. Direct transformation allows the classical analogy of actions on a particle in the form of the Lorentz force. The indirect transformation is related to the spin of the particles. Power direct process approaches the quantum during  $\mu$  limit in limited areas of biophysical systems (of membrane us) q.s. atom internally protected from the external environment. In these locations, which are often key to biochemical (immunochemical) reactions, nuclear spins become a significant factor. It is noted that the details of the configuration of the magnetic field that are essential for the response of a biological system are: 1) the dependence of the frequency of the effective magnetic field on the magnitude of the direct current; 2) the temporal orientation of homogeneous constant and variable magnetic fields; 3) the states of polarization of the variable ELF EMF. All of these facts are characteristic of the phenomenon of spin magnetic resonance. [6]



Irreversible chemical reactions create favorable conditions for the biological amplification of weak signals. Many biophysical molecular systems that ensure the proper course of immunochemical reactions have regions protected from external influences, which allows us to conclude that there are no fundamental prohibitions that limit the consideration of molecular biochemical systems as primary receptors for MFs with the participation of spin degrees of freedom. [7]

In the course of life, cells exchange information. At the same time, they generate electromagnetic signals. The ability of biological objects to maintain the constancy of the internal environment under changing external conditions, as well as to adequately respond to signals, is largely due to the functioning of cooperative systems with a threshold response. An example of such a system is the system of voltage-gated ion channels. In such systems, the steady state switching parameter value is close to the threshold, so a small change is sufficient to cause the system to switch. Now the attention of researchers is attracted by the phenomenon of stochastic resonance, which consists in the fact that in a bilayer or multistable system influenced by noise and a periodic signal, the signal-to-noise ratio in the response of the system passes through a maximum when the external noise increases. When there is no periodic signal, the switchings are also purely random, while when a signal appears, they more or less correlate with it. This component of the response correlated with the signal is indistinguishable at low and high noise intensities, but at some intermediate (resonant) value of the noise intensity, the correlation is improved. If we consider the effect of a weak EMF on a cell within the framework of the stochastic resonance hypothesis, then we can assume that the primary antenna is a bistable ion channel. Periodic exposure causes a synchronous change in the conductivity of the ion channel (pull - push), accompanied by a change in the conformation of the corresponding protein (for example, a virus protein). Also, synchronous rearrangements of many channel proteins can then lead to a synergistic effect with the creation of complex structures on the membrane. [8]

Of particular interest are the effects of ELF and ELF EMFs on the virus-host cell communication systems, especially in light of the recent COVID-19 pandemic. Studying the links between the increase in solar activity and the spread of various diseases, it was shown that outbreaks of plague, cholera, diphtheria, influenza and other viral infections coincide with periods of increased solar activity. Investigating photobacteria showed that on magnetically quiet days bioluminescence is stationary, but significantly changeable during

magnetic storms. Based on a large number of studies, it has been established that a constant magnetic field can strongly affect the growth and reproduction of microbes. [1]

## CONCLUSIONS

Thus, the effect of ELF EMF on the biological system (with induction from 1 to 120 mT) leads to resonant electricity with oscillations in the protein molecule, due to the electrostrictive effect in proteins, a mechanical wave propagates in the volume of the protein globule, which, possibly, affects on the processes of communication between the protein membrane in and the rush and the membrane of the host cell. In addition, literature data indicate that the main communication processes occur in the diffusion layer, in which there are no cells and are not associated with membrane processes and RNA. In any of the considered theoretical options, the dominant role is assigned to the protein molecule, which is easily subject to allosteric changes due to its specific spatial structure.

## REFERENCES

1. G.I. Kasyanov, R.S. Reshetova, V.T. Khristiuk and A. Khripko "Application of LF EMF in food production technology", "Ekoinvest", Krasnodar, 2018 (monograph).
2. Mukhamadiyeva Z.B. "Quality, safety and traceability in the supply chain", *Universum*, No. 3, 2020
3. Mukhamadiyeva Z.B., Mukhamadiyeva K.B. "Economic and social aspects of information exchange" In the collection of scientific papers, BSU international conference, Belgrade, 2020
4. Campbell K. "Information management", DFID, NRI, "University Greenwich", UK 2009
5. Mukhamadiyeva Z, Sharipov M, "Communication in Agri Food Supply Chain", *IJARSET*, II, 1740, 2020
6. Mukhamadiyev B.T., Sharipova N.U. "Nonthermal mechanisms of action of a low frequency electromagnetic field on plant raw materials", *Universum*, 6 (72), 89, 2020
7. Mukhamadiyev B.T., Gafurova G.A. "The use of an electromagnetic field (EMF) of low frequency (LF) in the food industry", *Universum*, 3 (69), 45, 2020
8. Mukhamadiyev B.T., Turaeva Kh.T. "Influence of the electromagnetic field (EMF) of low frequency on protein molecules", "Development of science and technology", *BITI*, No. 6, 131, 2020



# AN UNINTENDED DISEQUILIBRIUM: IMPACTS OF COVID-19 AND LOCKDOWN ON MENTAL HEALTH, WELL-BEING AND THE STRIVE OF MANKIND

**Tanmoy Kumar Bhattacharjya**

*Assistant Teacher, Bishnupur Heritage School*

## ABSTRACT

*The crisis caused by the unexpected yet unavoidable emergence of covid-19 pandemic has opened up new areas of discussion as well as of tension. Our very existence is put into question. This pandemic has created a drastic effect on both our physical and mental existence. This paper focuses on the psychological tension, caused by an immediate joblessness, homelessness and disconnectedness from society. All these crises have created an unavoidable stress that impacted our overall well-being. Lockdown, taken as a preventive measure against the pandemic, has confined people to their own lonely selves. Social isolation has caused a vacuum where the integrity of human society seems to collapse. The immediate stress and stigma due to this isolation and confinement have been the major issues of this paper. Loneliness has been the very imminent by-product of this lockdown. People's effort in being creative has been a major means to overcome loneliness. This paper also highlights the possible fruitful ways to get over loneliness. Several real life data and information have been collected to focus on the issue. Another focal point is the deterioration of economy, education, and production etc. due to the impact of covid-19. It has been found that covid-19 has damaged the living condition of all the classes, from rich to poor (mostly hampering the marginal community) to such an extent where they are forced to repent over the situation.*

**KEYWORDS-** Covid-19, Pandemic, Mental Health, Well-being, Stress, Stigma, Loneliness, Lockdown.

## PANDEMIC & MANKIND

The history of human civilization is abundant with epidemics. If we date back to the history starting from 430 B.C. to till date, mankind has been challenged by disastrous pandemics. When an epidemic crosses its country border and victimizes maximum people, it is called pandemic. 'Pan' suggests universal and 'demic' is derivative of Greek 'Demos', i.e. all people. In that sense the area of pandemic is stretched to the whole world. Covid-19 pandemic takes us into the history of pandemics that affected mankind to great extent. 1350 Black Death took a toll on one third of the world population. In 1665 Great Plague of London devastated the city as well as Europe. Cholera pandemic in 1817 and the third Plague pandemic 1855, 1889 Russian Flu, 1918 Spanish Flu, 1957 Asian Flu, 1918 HIV or AIDS, 2003 SARS and the latest covid-19 pandemic- these all are horrifying instances of the helplessness of humanity". (History, 2020) But different from other pandemics, the dimension of covid-19 is so large that almost no one is free from the unavoidable impacts of it. Besides taking a high toll on human lives, Covid-19

pandemic exempted almost nothing and no one. Human lives, economy, both physical and mental health, overall well-being and every sector of society that support humankind tended to collapse. An irreconcilable crisis caused imminently, has put humanity into many challenges. The immediate joblessness, homelessness, helplessness as well as disconnectedness from society are the major unintended consequences of the pandemic. This loss is beyond compensation. Lockdown adopted as a preventive measure to break the chain of transmission rolled out as having impacted the overall condition of human being. Human being has been initially locked into home which created an undesired distance from society. The increasing loneliness of the people started to affect the physical and mental existence of one.

Our overall well-being is an accumulation of both physical and mental calmness. Imbalance in any of the two unquestionably arises imbalance in the well-being. In our modern living, life is conditioned by many dominant factors. Our position in life, job, family & social network, prospects of future and daily life



hazards- all determine our overall physical and mental stability. Any unintended and undesired addition to life or subtraction from life instigates imbalance of which stress is the immediate outcome. Stressors that are inculcated into our daily actions worsen life and living. A prolonged stress may result in stigma.

The long-term lockdown, initially implemented, adversely gave birth to confinement, loneliness, joblessness for many & disconnectedness. The social chain of mankind was withheld in order to dismantle the transmission chain of covid-19. Lockdown and loneliness become synonymous. Man's social position has been continuously put into question.

With the rapid modernization of human life, stress has occupied a dominant place in the very bosom of our daily life. Any challenge that is beyond solution and beyond coping abilities arises stress. Psychology defines stress in diverse ways. Stress has a direct reflection on our personality, emotion and both on physical and mental wellness. The agent which produces stress is called stressor. Some stresses are naturally attached to a modern living while some other are forcefully added. The binary elements like job and joblessness, home and homelessness, association as well as dissociation produce stress. Covid-19 lockdown has introduced some unavoidable circumstances which have direct bearing on physical and mental health. The concept of mental health evokes two ideas- 'mental' & 'health'. "Mental health is the level of psychological well-being or an absence of mental illness. It is the state of someone who is functioning at a satisfactory level of emotional and behavioral adjustment...mental health may include an individual's ability to enjoy life and create a balance between life activities and efforts to achieve psychological resilience". (Mental Health) So, mental health is a way of living peacefully with the other members of the society. With the sudden and abrupt emergence of Covid-19 and lockdown, taken as an effective measure, this mental stability has collapsed. A restlessness and despair pervaded the mind. The overall well-being is shaken. Naturally, man's ability to cope with stress has decreased. The normal functioning to deal with the challenges as been restricted. With the breakdown of global economy, several grave problems came to forefront. Unemployment rose from 7% (March) to 27% (May). People who lost jobs had to adopt alternative income source. Major companies had to count loss. Stock markets incurred a huge loss. These all have impacted life at a direct-level. The condition of the marginalized worsened, death for them became an easier choice. The whole mankind had been stigmatized.

Against this backdrop, this paper focuses on the stress, stigma and the imbalance of mental health along

with the possible measures, which may be taken to get rid of primary loneliness. The loneliness may be directed towards solitude which is creative and fruitful. Psychological remedies discussed in this paper may add meaning to human life and existence.

## REVIEW OF LITERATURE

Researches have been done on the issue of covid-19 pandemic and its immediate effect on physical and mental well being. Many researchers with real-life data have attempted writing on the issue of stress, stigma that has a direct connection with Covid-19. Leia Y Saltzman in "Loneliness, Isolation and Social Support Factors in Post-Covid19 Mental Health" discusses the potential impact of covid-19 on loneliness and well-being. Emphasis has been given on societal support, psychological skills that may help in psychological recovery.

Lambert Zixin Li, Senhu Wang in "Prevalence and Predictors of General Psychiatric Disorders and Loneliness during Covid-19 in the United Kingdom" investigate the prevalence and predictors of psychological disorders.

## METHODOLOGY

The study with some real life incidents, happened during the period of covid-19 pandemic investigates into the primary cause of stress and imbalance in mental order. The overall impact of covid-19 on human life has been discussed here. This study focuses on the connection between loneliness and lockdown. The possible ways of reducing stress and channelizing loneliness towards solitude have been discussed in this study.

## PANDEMIC AND STRESS

Whenever the natural flow of life is challenged, it produces stress. Stress is an outcome of the immense overload of work, man's inability to cope with difficulty. Everyone is tagged with stress but in his or her own way. People have diverse reactions to challenges in life. Covid-19 has given birth to a collective stress. The stressors that are behind stress cause disequilibrium in body as well as in mind, which deters well being. One's well-being consists of both physical and mental stance.

Covid-19 pandemic has forcefully imbalanced the current of life by instilling stressors into life. With the continuous threat of getting affected by covid-19, men's mental stability is randomly oscillating. The global economy collapsed. For many, source of income was choked. Hardly finding any alternative way, people had to starve. The immediate joblessness and





homelessness for many created an extra burden on life. Production stopped. An acute deficiency of food was created. The daily laborers had to pay much to supply food to the family. Survival in this crisis became a challenge.

### **FACTORS CONDITIONING STRESS DURING PANDEMIC**

The sudden and unprecedented inclusion of pandemic triggered stresses. Having no vaccine currently available, the uncertainty of a future regular life, the immense failures of resilience are directly linked to stress. This continued stress impinges us with stigma. Below are some of the primary concerns related to stress and stigma. Inclusion of stress emerging from various factors directly imbalances wellbeing. Strive of mankind is noticeable here too.

### **JOBLESSNESS**

Owing to a huge loss incurred to many private sectors, most people became jobless. "According to the data from the centre for monitoring Indian Economy, India's overall unemployment rate for the month of July stood at 7.43%, down from nearly 24% during the month of April. (Nalapat, 9) Joblessness and the loss of job both are serious cause of stress. The loss of income source actually refers to getting deprived of healthy living. The balance of mental health is completely disrupted. Distress and anxiety become very normal and common to all. Attempt of suicides rose unexpectedly. "According to WHO, one suicide carries 20 suicide attempts behind it". (Health topic/ suicide prevention, 2020) The unexpected rise of unemployment naturally triggered Suicide cases. "The downsizing of the economy and the focus of the medical system on the COVID-19 pandemic can lead to unintended long-term problems for a vulnerable group on the fringes of society. (Kawohl&Karl Nordt, May, 2020) Covid-19 pandemic affected the society at a base level.

### **HOMELESSNESS**

Man, when rooted out of his comfort zone feels at sea. His alien existence is a threat for himself. He feels to be disconnected and isolated from society. With the emergence of covid-19, man's social position has been threatened. The migrant workers are the worst sufferers. With the shutdown of factories and workplaces for the implementation of lockdown, their lives were challenged with starvation, homelessness, denial of medical care, leading to suicide even. Life got stranded. "Due to lockdown, more than 300 deaths were reported till 5th May, with the reasons ranging

from starvation, suicides, exhaustion, road and rail accidents, police brutality and denial of timely medical care. On 8th may, 16 migrant workers lost their lives as they were crushed to pieces when they had stopped to rest after the long walk on railway tracks near Aurangabad in Maharashtra". (Indian\_migrant\_workers\_during\_the\_COVID-19\_pandemic) As of 2nd June, 198 migrant workers were feared killed in road accident, according to the data collected by SaveLIFE Foundation. (About two hundred workers lost lives in road accidents: savelife foundation) This unprecedented homelessness triggered the rate of unemployment. Again, the stressful situation arose when they were not accepted in the native places due to the fear of spreading infection. Either they were harassed or edged. The loss of job imposed on social isolation almost created a stigmatized existence. Another thing is that "When a family of more than 10 struggles to find accommodation in a limited area on the streets, it is but fanciful to mention social distancing." (Bhattacharya, 2020)

### **DISCONNECTEDNESS AND DISEQUILIBRIUM**

Social isolation becomes social disconnection. One's initial existence becomes meaningful not in a solution but in connection with the other members of the society. The social distancing and isolation, followed to check the further transmission produced a new epidemic called "Loneliness epidemic". We entered a period of social pain. The people who have pre-existing mental illness suffered the most due to social isolation. Old people who are mostly dependent on other members lost their meaning of life. This abrupt disconnectedness created disequilibrium, a state of mental disorder inside. The stress produced due to this detachment is beyond recovery. Man has become alien in his own society. The fears of contagion automatically produce distance from others. Staying safe from infection rolled out with another contrary definition- infected with disconnection, with loneliness.

### **STRESS AMONG THE FRONTLINE WORKERS**

The depression and anxiety related to the job of the front line workers are most noticeable. Their job is almost like belling the cat. Dealing with the Covid-19 patients under immense pressure and constant threat, the fear of contagion, overload of work, and the unnatural appearance of the virus the never faced before, all are enough to imbalance the mental stability. The risk of infection, separation from family, lack of social support, absence of proper medical facility- these





things disrupted the concept of mental well being, sometimes leaving a long term mental disorder. Unlike other front line workers, viz. Police, Food supply officials, the health workers are more likely to experience psychological imbalance, a mental disequilibrium, increased level of anxiety, insomnia, and depression and sometimes a prolonged mental disorder too. The sacrifice they are making for the larger human civilization sometimes layers stress, fear and terror inside. Many had to pay their life for greater cause. This triggers the vulnerability to mental stress. The lack of social support in some cases intensified the prolonged trauma. In some areas, doctors and nurses were not allowed for the fear of contagion. This societal separation detached them from the flow of mankind. It needs to be addressed positively.

### STIGMA AND COVID-19

“Social stigma, in the context of health, is the negative association related to people or a group who have a specific disease in common. In an epidemic, this may mean that people are labeled, stereotyped, and discriminated against because of a perceived link to the epidemic. This is even more true when dealing with a highly contagious disease. This can have a negative effect on those affected by the virus and on the work of HCWs”. (Phelan, 2001) The discrimination and stigmatization of people on the basis of caste, creed, and religion is not new. The outbreak of covid-19 initiated fear anxiety and depression among people which ultimately led them to labeling people. The front line workers who are in the direct management of covid-19 are mostly labeled. The fear of contagion, the lack of adequate information, fake information circulated through social media created an immediate stigma. Besides the frontline workers who are discriminated and stereotyped for their direct exposure to the disease, the patient and the quarantined people, even their families are facing stigma and discrimination. Covid-19 has pervaded a stigmatize existence and it needs to be addressed. The effect of the stigma and discrimination mostly led people concealing symptoms, avoiding medical care. People fear to home quarantined. The stigma attached with this pandemic threatens self-esteem and confidence. With the increasing number of unreported cases as a result of emotional isolation, feeling of guilt, anxiety, Covid-19 management becomes harder. According to the statement made by Pujja Hati, a nurse at Khatra Hospital, Bankura that unlike other diseases, the presence of terror is very much among the people when it is the matter of Covid-19. Doctors and nurses were refused rent due to the fear of contagion. They faced lots of hardships. They were

denied shelter. These all happened because of the primary labeling and stereotyping. Even they were stigmatized nonetheless they worked as warriors. She felt isolated too for her distance from family, relatives. This had a direct impact on the mental happiness. Peace and relaxation of mind became almost an imagination.

The community collapsed. The prejudice against people and certain groups of people culminated into increased hostility and unnecessary social disruptions. People made the choice to remain safe by cutting away from larger society. On the other hand, stigma triggered the feeling of isolation, leading to the imbalance in mental stability. Patients with health workers and other front line workers got loaded with unnecessary stress, as their existence seemed alien to the other members of the society. The concept of wellbeing disrupted, sometimes leading the stigmatized people to end the lives.

### LONELINESS AND LOCKDOWN

Loneliness which is a subjective experience triggers imbalance in mental health. A prolonged state of isolation and disconnectedness may instill loneliness. Remaining safe from infection had a detrimental effect on the overall well-being as it made people lonely. The Covid-19 pandemic has certainly halted the modern society disrupting the social interaction. Loneliness for people gave birth to boredom, sometimes triggering inter-personal violence and irritation of mind. Forcing the mind into stagnant situation, it has increased vulnerability to depression, anxiety and other mental disorders. Man's productivity has been forcefully put into challenge. Experience of people regarding loneliness happens at different level. Covid-19 situation has altered the definition of loneliness. Loneliness is basically a void filled with terror, depression. When man fails to fix his own identity in the great human civilization, it brings out loneliness. The wholesomeness of living is torn into pieces. The effect is rather deeper on the aged persons. Their dependence on other members is challenged when the natural amalgamation of people got choked due to lockdown. Man's strive to get rid of this loneliness is also noticeable. Weather the loneliness or lockdown- both are imposed- two external factors conditioning life, men strived hard to get over loneliness, by following creative methods. For most of the poor, old people, this was a life-choking experience as there was less exposure to communication and social interaction.



## LONELINESS TO SOLITUDE

Loneliness which is a personal void, filled with anxiety, fear, and the sense of disconnection can be channelized into solitude which is a creative faculty. The great works of art in literature are the products of experience of solitude. Solitude increases the sense of integrity. While the greater numbers of people inhabit loneliness, solitude may fill them with an increased sense of social connection. One's ability to be at peace with oneself is the ultimate solution to the feeling of loneliness. The long-forgotten hobbies, creative works, neglected passions may be practiced again to channelize loneliness into solitude. Though the intensity of covid-19 is vast enough, disaster in the history of humanity is not a new one. The immediate loneliness has a solution in the domain of solitude where men will find the meaning of life and enjoy the aloneness.

## CONCLUSION AND THE WAY FORWARD

The impact of Covid-19 is so large that it has spared almost no one, deteriorating his or her overall well being. The older persons are mostly victimized. With the heavy toll of lives, Covid-19 pandemic has dismantled the order of the society, physical and mental well being. Spending more time with family, staying away from the maze of misinformation circulated through social media, taking care of infected and old persons may add to the good of the human community. It is the joint and collective strive of mankind that will help cure the detrimental effect. Maintaining the Government orders and instructions, people may remain connected through audio, video calls and other possible ways. Emotional support is very crucial in this time. Giving proper respect to the sacrifices of the frontline workers and reconsideration of human being as a part of greater community by staying away from any kind of stigmatization, labeling and stereotyping will definitely help overcome the harsh experience of Covid-19 pandemic.

## REFERENCES

1. *Health topic/ suicide prevention.* (2020). Retrieved August 2020, 23, from [www.who.int: https://www.who.int/health-topics/suicide#tab=tab\\_1](https://www.who.int/health-topics/suicide#tab=tab_1)
2. *About two hundred workers lost lives in road accidents: savelife foundation.* (n.d.). Retrieved August 2020, 23, from [www.economictimes.com: https://m.economictimes.com/news/politics-and-nation/about-200-migrant-workers-lost-lives-in-road-accidents-during-lockdown-savelife-foundation/articleshow/76159935.cms](https://m.economictimes.com/news/politics-and-nation/about-200-migrant-workers-lost-lives-in-road-accidents-during-lockdown-savelife-foundation/articleshow/76159935.cms)
3. *Bhattacharya, D. B.* (2020, May 14). *the hidden vulnerability of homelessness in the Covid-19*

- pandemic: Perspective from India.* Retrieved August 24, 2020, from [www.scholar.google.com](http://www.scholar.google.com).
4. *Editors, H.* (2020, January 30). *History.* Retrieved August 23, 2020, from <https://www.history.com/topics/middle-ages/pandemics-timeline>
5. *Indian\_migrant\_workers\_during\_the\_COVID-19\_pandemic.* (n.d.). Retrieved August 24, 2020, from [www.wikipedia.org](http://www.wikipedia.org).
6. *Kawohl&KarlosNordt, W.* (May, 2020, May 2020). *Covid 19, unemployment and Suicide., The Lancet, 389-390.*
7. *Mental Health.* (n.d.). Retrieved August 22, 2020, from [wikipedia.org: https://en.m.wikipedia.org/wiki/Mental\\_health](https://en.m.wikipedia.org/wiki/Mental_health)
8. *Nalapat, S.* (9, August 2020). *How the Covid 19 outbreak has effected the joblessness rate in India-explained in four charts.* Retrieved August 2020, 23, from [www.Timesnownews.com](http://www.Timesnownews.com).
9. *Phelan, B. G.* (2001). *Conceptualizing stigma. Annual Review of Sociology, 363-385.*



# DEVELOPMENT OF ECOLOGICAL TOURISM IN UZBEKISTAN

**Atadjanova Sayyora Melisovna**

*Candidate of Historical Sciences, Associate Professor of National University of Uzbekistan named  
after Mirzo Ulughbek*

---

## ABSTRACT

*This article analyzes the development of tourism in Uzbekistan and its new direction, ecotourism, based on archival materials and scientific literature. The material on the development of ecotourism at the present stage in Uzbekistan is provided and the problems associated with the development of ecotourism in the republic are considered.*

**KEY WORDS:** *ecological tourism, eco-center, nature reserve, tourism fair, global economy, infrastructure, agreements, travel companies.*

---

## DISCUSSION

Tourism today is one of the leading and most dynamic sectors of the world economy. For its rapid growth, it is recognized as the economic phenomenon of the century.

According to the World Tourism Organization (WTO), the number of arrivals in 2000 was 698 million, and the amount of tourism receipts was \$ 478 billion. According to the forecasts of WTO experts, the number of trips in the world by 2010 may reach 1 billion tourist arrivals, of which 546 million will be in Central and Eastern Europe, including the CIS and Baltic countries, where tourism will develop at a faster pace than the European region as a whole [1].

The development of tourism in the republic is one of the economic sectors of the national economy, capable of creating thousands of new jobs in the future, accelerating the development of regions, increasing the income and quality of life of the population, which in turn will lead to an improvement in the country's image and investment attractiveness.

The tourism industry in Uzbekistan began its development in the 90s of the XX century, with the development of a market economy in independent Uzbekistan.

In this regard, in order to activate a new branch of the economy, namely tourism, the leadership of the Republic of Uzbekistan has taken a number of steps to develop the infrastructure of international tourism in the republic. This is

evidenced by the fact that even in the early years of the country's independence, a special resolution of the Cabinet of Ministers of the Republic of Uzbekistan "On the development of international tourism infrastructure" created conditions for the development of the internal structure of the tourism industry and improving the quality of service. By a separate decree of the Cabinet of Ministers of October 20, 1992 "On the organization of the activities of the National Company" "Uzbektourism", in December 1992, the foreign trade association "Uzinturservice" was created. The main task of which was to conduct export-import operations for the company as a whole, as well as to provide various amenities for receiving foreign guests and providing them with various services [2].

The national company "Uzbektourism" in 1993 as a full member was admitted to the World Tourism Organization. This opened up wide opportunities for establishing close contacts with travel companies in many countries of the world, and raised their interaction to a qualitatively new level. At the same time, Uzbekistan, like many other countries of the world, has become a permanent participant in the International Tourism Fair (ITB) annually organized by the World Tourism Organization [3].

So, having created the necessary tourism infrastructure in the country and entering the orbit of international tourism, Uzbekistan began to build and implement a wide network of cooperation with travel



companies and firms of foreign countries and also to promote the tourism product in all directions.

The new industry began to develop rapidly and already in the first years of independence showed a good result, as evidenced by the following indicators. If in 1998 the total number of tourists visiting our republic was 6131 people, then in 1999 - 6940; in 2000 - 11155; in 2001 - 21174; in 2002 - 16,792; and in 2003 - 10,490 people [4].

In 2016, the number of operating travel companies amounted to 433 units, compared to 2012 by 75 companies more. The number of persons who received travel services in 2012 amounted to 511.6 thousand people, and in 2016 - 465.4 thousand [5].

From year to year in the world there is a steady upward trend in the number of international tourists. For example, in 2018 this figure reached 1.4 billion, and tourist exports amounted to 1.7 trillion US dollars. Thus, a country with tourism potential is simply obliged to develop its tourism industry. Uzbekistan is undoubtedly one of such countries [6].

According to the World Tourism Organization (UNWTO), tourism ranks fourth in world exports of goods and services, and in terms of profitability - third. Its share in world GDP is 10% [7].

International tourism continues to show strong and unrelenting growth, exceeding that of the global economy, with no significant signs of abating given that global arrivals are expected to grow 3.3% from 2010 to 2030, and will reach 1.8 billion by 2030, according to UNWTO's long-term forecast report *Tourism on the road to 2030*. Between 2010 and 2030, tourist arrivals in developing countries (+ 4.4% per year) are expected to grow at a double rate of that of developed economies (+ 2.2% per year). With the exception of Afghanistan, the Chinese Autonomous Regions of Inner Mongolia and Xinjiang Uygur Autonomous Region, and Turkmenistan, cumulative international tourist arrivals in the CAREC region in 2018 are estimated by the World Tourism and Travel Council (WTC) at just under 20 million, with growth projected ten years to 2028, almost 5%. Despite this, considered in a global context, the total share of CAREC countries (excluding the People's Republic of China) is less than 2% of world tourism [8].

A new turn in the development of tourism infrastructure, as well as in order to ensure its development, create favorable conditions and preconditions for the development of the private sector and increase tourist flows to the republic by the Decree of the President of the Republic of Uzbekistan dated December 2, 2016 No. UP-4861 "On measures to ensure accelerated development tourism industry of the Republic of Uzbekistan", an authorized state body was formed - the State Committee of the Republic of Uzbekistan for

Tourism Development, as well as by more than 30 decisions of the Head of State and the Government of the country, significant tax benefits and other preferences were provided to the subjects of tourism activities, the entry visa regime was canceled and simplified, innovative technologies were introduced in the field of tourism, conditions have been created for the effective promotion of the national tourism potential in the domestic and foreign markets [9].

Ecological tourism occupies a special place in the tourism industry of the countries. Now all over the world there is a tendency of development of this sector of the tourism industry. But often ecotourism is perceived only as a fashionable trend in the tourism industry. Ecotourism instills a love of nature, enhances the ecological culture of travelers, "respects" the interests of the local population and contributes to nature protection [10].

In Western countries, ecotourism is gaining more and more popularity from year to year. Almost every traveler chooses environmentally friendly trails for their routes. In the modern world, today ecological tourism is gaining popularity. Among the people, it is also called the "wild campaign", which, in general, has always been popular, but among a limited number of the local population of the republic. This type of recreation is now attracting more and more foreign tourists. This can be explained by the hustle and bustle of everyday life and the desire to relax in silence on the territory of a living, untouched by industry, pure nature. According to statistics, most tourists prefer direct live communication with nature [11].

Spending more time in untouched corners of nature, walking along the trails after animals, now it is becoming not only useful, but also fashionable. People began to prefer rest with their families on the territory of reserves, forest thickets or mountains. The people call this type of this tourism "green" or "soft" [12].

Uzbekistan has unique nature attractive for visiting guests, diverse landscapes (steppes, deserts, mountains, plateaus), various areas of flora, rare geological deposits, numerous architectural monuments that preserve the centuries-old history of our region.

Another treasure of the nature of our region is the Ugam-Chatkal State National Natural Park, located in the Tashkent region. The Chatkal Biosphere Reserve is located in the south of the Ugam-Chatkal National Park. The reserve is divided into two sections - Boshkizilsoy and Maidontol. The first one extends on the southern slopes of Chatkal, the second - on the northern slopes and glaciers. The picturesque landscapes of the reserve are represented by mountain ranges decorated with juniper forests, high-mountain alpine and xerophytic meadows and windy steppe zones. The Chatkal reserve is all dotted





with mountain patterns, caves and noisy waterfalls. And in the southern part of Maidontol, on the rocks near the banks of the Tereksai, in the Karasau tract, you can observe ancient rock paintings - the Tereksai petroglyphs. Even in the Chatkal reserve, very interesting bird watching tours are held [13].

The projects of the Eco-Forum of NGOs of Uzbekistan contributed to the involvement of the local population in ecological tourism activities on the territory of the Ugam-Chatkal National Park. The Rodnichok NGO promotes the development of youth ecotourism in the mountainous regions of the Tashkent region. Many summer camps, boarding houses and rest houses are located here, as this picturesque place seems to be just created for a comfortable pastime. Since 2017, the park has been included in the UNESCO World Heritage List, and its protected part is closed for free visits.

One of the places actively visited places of ecotourism is the Ecocenter "Jeyran", created in 1997. It is located in the Kyzylkum desert, 40 kilometers from Bukhara. Its work is regulated by the State Committee for Nature Protection of the Republic of Uzbekistan. This is a nature reserve nursery, where endangered species of animals are bred. In the Ecocenter, gazelles, this rare species of animals, were studied and bred, and methods for the rational use of the population were developed [14].

Ecocenter actively cooperates with international environmental organizations, educational institutions and eco-movement. Various, world-renowned research centers regularly send their specialists to exchange experiences and train on the basis of the Ecocenter. Judging by the reviews of tourists, you can visit the eco-center with your family, live on the territory and enjoy the biodiversity of this place, or you can come as a volunteer and take an active part in the activities of the center. This, in turn, allows you to get closer to nature, to feel like a single whole, to become involved in solving the global task of reviving and preserving the population of the rarest animals, and also to make your own contribution to the nature conservation mission [15].

The natural and climatic potential of the republic is very diverse and rich - mountains with numerous caves, glaciers and lakes in the Tashkent region and the Fergana Valley, steppes, deserts and oases in Navoi and Bukhara regions, mountain landscapes in Kashkadarya and Surkhandarya regions, arid landscapes of Kyzyl Kum, large reservoirs with a rich avifauna in Karakalpakstan, Jizzakh and Syrdarya regions. As well as forests in the delta of the Amu Darya river, and the recently opened Kitab reserve, which testifies to the emergence of life on our planet, the region of "ecological disaster" near the Aral Sea, Nurata mountains and Lake Aydarkul, and many other natural places [16].

In order to promote the tourism product and facilitate the procedures for its promotion, a number of measures were taken in this direction.

In pursuance of the Decree of the President of Uzbekistan Sh. Mirziyoyev "On measures for the further development of the tourism sector in the Republic of Uzbekistan" from October 1, 2019, the "Open Skies" regime was introduced at the international airports "Karshi", "Nukus" and "Termez" with the use of the "fifth freedom of air" [17].

Also, according to the decree, the "Open Skies" regime is introduced at the "Bukhara" airport - with the use of the "fifth freedom of air" when transporting citizens of foreign states.

The fifth degree of "air freedom" is a right in relation to scheduled air transportation, granted by one state to another, according to which the designated carrier has the right to unload and take on board in the territory of the partner country, by agreement, passengers, mail and cargo coming from a third state or into it [18].

In order to develop and expand the tourism sector in the republic, the Concept for the development of the tourism sector in the Republic of Uzbekistan in 2019-2025 (Appendix N 1) to the Decree of the President of the Republic of Uzbekistan was developed and approved. from 05.01.2019 N UP-5611. The aim of which is to transform tourism into a strategic sector of the national economy. It touches upon the issues of further improving the regulatory framework in the field of tourism, implementation of international norms and standards, further liberalization of the visa regime for citizens of economically stable and safe states, providing the main flow of tourists in the republics [19].

An important issue is the development of new tourist programs, taking into account promising types of tourism (pilgrimage, educational, ecological, ethnographic, gastronomic, sports, health-improving, rural, industrial, business and others) to create a diverse, attractive and competitive tourist product at different times of the year. Of the Republic of Uzbekistan, including through the creation of thematic tourist zones and clusters in the regions of the country. To ensure the safety of tourists on the territory of the republic, it is planned to create specialized divisions of the internal affairs bodies to ensure safe tourism in the territories with the greatest tourist potential, equip them with modern technical and transport vehicles [20].

In this direction, work has been done to implement new transformations. The internal affairs bodies pay close attention to this area of activity. In particular, the Department for Coordination of Ensuring Safe Tourism of the Ministry of Internal Affairs is carrying out effective work to ensure the safety of





foreign tourists, to provide the necessary assistance for them in the route lines of their visit.

Another important issue in this case is the appearance of employees. It is the focus of the Safe Tourism Division. Recently, a project has been developed for a sample of a new uniform for employees of tourism departments. Uniforms of a new type are being tested by employees of the Tashkent and metropolitan service [21].

It should be noted that in the Department for Coordination of Ensuring Safe Tourism of the Ministry of Internal Affairs of the Republic of Uzbekistan, a "Call Center" began its activity, the main task of which is to receive calls from tourists by phone and promptly organize the provision of the necessary assistance to them within the powers of the internal affairs bodies.

The call center is equipped with modern information and communication equipment and is connected to the duty units of the regional departments for ensuring safe tourism of the Central Internal Affairs Directorate of Tashkent, Tashkent, Bukhara, Samarkand, Surkhandarya, Kashkadarya and Khorezm regions [22].

Help will be provided by qualified specialists who are fluent in Uzbek, Russian and English, and who work around the clock, seven days a week. Ecotourism is one of the new directions of tourism today. And in this direction, our government takes a lot of efforts to improve its service that meets international standards. In this area, active work is underway on large-scale projects aimed at expanding tourist routes, organizing tourist services, and protecting the environment. For these purposes, organized and conducted master classes, trainings, seminars for guides of service personnel and owners of guest houses.

## REFERENCES

1. Big Leningrad Library "Tourism Industry" Electronic resource // <http://www.6yket.ru>.
2. Nuriddinov E.Z. International cooperation of the Republic of Uzbekistan with European countries, T.-2002. C174.
3. Atadjanova S.M. Development of tourism in Central Asia (on the example of Uzbekistan and Kazakhstan) // EPRA International Journal of Research Development (IJRD) Volume: 5, Issue: 4, April 2020.-P.242.
4. Current archive of the National Company "Uzbektourism". Folder Kyrgyzstan. P.17.
5. Gaibnazarova Z.T. Prospects for the development of the tourism potential of Uzbekistan // Scientific research of the Faculty of Economics. Electronic journal. Volume 10. Issue 1. P.96. <https://archive.econ.msu.ru/>
6. Selimanova SM, Tursunova SR Ensuring the safety of tourism by the internal affairs bodies of the Republic of Uzbekistan // Academic research in educational sciences Volume 2 | Issue 2 | 2021 Scientific Journal Impact Factor (SJIF) 2021: 5.723 P.1104.
7. Ibid. P.94.
8. Promoting Regional Tourism Cooperation Under CAREC 2030 Scoping Study. 2019.C.5-6.
9. Collection of legislation of the Republic of Uzbekistan, 2017, No. 1, p. 3
10. Lesko E.G. Potential advantages and disadvantages of ecological tourism // State and prospects of tourism development in the Slavic states. Section V. Conference materials P.248.<https://elib.gstu.by/>
11. Advantages and disadvantages of ecotourism <http://www.greeceabout.ru/content/>
12. Ibid.
13. Chatkal Biosphere Reserve // <https://uzbekistan.travel/ru/>
14. "Ecocenter" Jeyran <https://canaan.travel/attractions/28-bukhara/>
15. Ibid.
16. Prospects for the development of ecotourism in Uzbekistan // <https://uznews.uz/ru/article/>
17. Evgeniya Yun. The potential of ecotourism in Uzbekistan: from educational function to high technologies // Pravda Vostoka. 10 July 2020
18. On measures for the further development of the tourism sector in the Republic of Uzbekistan, August 19, 2019 // <https://tma.uz/ru/>
19. Ibid.
20. Collection of legislation of the Republic of Uzbekistan, January 14, 2019, N 1-2, art. five
21. A sample of a new form of employees of internal affairs bodies serving in the field of tourism is undergoing testing <https://iiv.uz/ru/news/>
22. The "Call Center" of the Department for Coordination of Ensuring Safe Tourism of the Ministry of Internal Affairs of the Republic of Uzbekistan began its activities on January 6, 2021. // <https://iiv.uz/ru/news/>



# A STUDY ON CHANGE MANAGEMENT AT COMMERCIAL TAXES DEPARTMENT

**Amtul Wahab**

*Research Scholar from OU, Lecturer in Commerce,  
Indira Priyadarshini Govt. Degree College for Women, Nampally, Hyderabad*

## ABSTRACT

*An organizational theory furnishes a general frame of reference for explaining and understanding behavior pattern in organization. The study is the impact of the change management at Commercial taxes Department. To study the perception of Commercial taxes Department's employees towards the Change ie Computerization. The period of the study is for the year 2008-2009. Primary data is directly collected from the respondents i.e. employees of the Commercial taxes Department through a structured formalized questionnaire. Secondary data has been collected through websites, library books & journals. The sample size is restricted to 50 only. The study and analysis are purely based on information given by the respondents i.e. employees of Commercial taxes Department, Charminar Division. The period of the study is for one year.*

**KEYWORDS:** *Change Management, Commercial Taxes Department, Computerization, Perception of the Employees, Organization Change*

## INTRODUCTION

Organizational theory is the discipline that studies the structure and design of organization. It explains how organization are actually designed and offers suggestions and how they can be constructed to improve organizational effectiveness.

An organizational theory furnishes a general frame of reference for explaining and understanding behavior pattern in organization. It also furnishes a scientific base for managerial actions for predicting , controlling and influencing behavior with a view to increase efficiency of the organization

Organizational Behavior is directly concern with the understanding, predicting and controlling of human behavior in organization. It is an area of study that investigates the impact that individuals, groups and structure have on behavior with in organizations for the purpose of applying such knowledge towards improving an organization's effectiveness.

Organizational Behavior examines individuals within organizational thoroughly and is concerned primarily with their emotional and cognitive difference within organization.

## Concept of Change

In dynamic society surrounding today's organization, the question whether change will occur is no longer relevant. Instead the issue is how do managers cope with the inevitable barrage of changes

that confront them daily in attempting to keep their organization viable and current otherwise the organization will find it difficult or impossible to survive.

## Meaning

Change means the alteration of status, quo or making things different . Any alteration that occurs in the over all work environments called as change.

## Definition

“ When an Organizational System is disturbed by some internal or external forces changes frequently occurs.”

## Needs and Importance of the study

The following are the needs and importance of the study:

- Change in any part of the organization affects the whole of the organization.
- Change will effect the various part of the organization in varying rate of speed and degree of significance.
- Changes may affect people , structure , technology, and other elements of the organizations.



- Changes creates certain responses these responses may be either positive, negative or neutral.

### Objective of the study

The following are the objectives of the study.

- To study the impact of the change management at Commercial taxes Department
- To study the perception of Commercial taxes Department's employees towards the Change that is Computerization.

### Period of the study

The period of the study is for the year 2008-2009.

### Scope of the Study:

- The scope of the study is restricted to study the impact of the changes in Commercial Taxes Department.
- The scope of the study is restricted to present the Change management at Commercial taxes Department.

### RESEARCH METHODOLOGY

The data was collected from primary and secondary sources.

Primary data is directly collected from the respondents i.e. employees of the Commercial taxes Department through a structured formalized questionnaire. Secondary data has been collected through websites, library books & journals.

**Samples: The Sample size is restricted to only.**

### LITERATURE SURVEY

\* Darren D Armstrong and Md Saeed "Change Management in Health Care Settings", The Indian Journal of Commerce, expressed in their article that "Employees engaged in the Change Management process is that, he or she should try to model himself or herself in to change leader rather than a change manager. Changes are going to offer opportunities to those organization that manage the change process well and remember that the future belongs to those who prepare for it."

\* Kirk Strawser (Head of WIPRO Consultation Services), "marketing Changes", Business India (The Magazine of Corporate World), expressed in his articles that "The consulting market must undergo a step change in how we approach the business of teaming with our clients to manage cost, capital and customers. Client want industry specific and integrated solutions delivered using innovation, accelerated approaches that drive measurable improvement in critical metrics such as cash flow and returns on equity."

\* Ashraf, "Changing Course Curriculum to Retain the Edge", Indian Journal of Marketing, expressed in his article that "In the content of rapidly changes global economy, Indian's Business Schools have to learn to cope up with emerging scenario. Manager should be more able to think and work internationally. Students should learn, to work in the emerging trans-geographic business environment. Further a major weakness of the Indian Management Education appears to be a wide gap between what is needed on the job and what is taught in the school. It call for changes, rather updating curriculum."

\* Saravanan S "Service Marketing Strategic for the new Millennium in Banking Sector", Indian Journal of Marketing, expressed in his article that; The changes in technology in the field of communication and computerization are expected to reach new heights in the coming decades. Consequently, the banking services will also get more modernized. The computerization will save more man power which can be used in other fields as well."

\* Sandhya Mehta, "Human Resource's Role As A Strategic Business partner", HRD News letter, expressed that, "Strategy for success of any organization in today's environment demand scoping with change. As a strategy business partner HR needs to play a critical role in anticipating these changes and preparing the organization to respond appropriately for continued competitiveness. In being the catalyst for change, he must engage himself in creating an atmosphere for learning and relating in the organization. It should also ensure that it facilitates through constructive feed back and coaching method."

\* P Ramlal, N Surakshitha and B Mathews, "Changing Dimensions in HRM", HRD news letters, expressed in their article that, "To cope with the change in the changing scenario and to compete with the highly competitive world, one needs a change in his knowledge. This is where the need for knowledge management arises to organizations to improve the knowledge of their employees."

\* Dr G Ramanaiah, "Emerging Business Scenario in the New Millennium and Challenges", expressed in his article that, "Thus the company trapped in the old mindset collapse while those with that right mindset are able to successfully handle the same paradoxes. Due to growing competition between company's worldwide, diversity in work force, borderless world and information availability in the advent of Internet, companies have to evolve strategies to effectively manager paradigm shift in organization. Organisation need to develop global vision, follow secular approach in dealing and customization in order to survive and grow in the 21<sup>st</sup> century."



\* Mrs Neeraja Guda ,” E-Business Trends and Issue “, Indian Journal of marketing, expressed in her article that “ Every company must learn to implement for reaching changes with in itself to take advantages of the ways so the internet allows to perform functions. The more an organization can use the internet to tie together the corporate infrastructure, goals and technology, the more effective it will be in realizing its goals and success.

**Limitations of the Study**

- The sample size is restricted to 50 only.
- The study and analysis is purely based on information given by the respondents (i.e. employees of Commercial taxes Department , Charminar Division)
- The data has been collected only from employees of Commercial department Charminar Division that is Commercial tax Officers, Deputy Commercial tax Officers, Assistant Commissioner Tax Officer, Senior Assistant, Junior Assistant , Senior Steno,

Typist and record Assistant ,since impact is only of these employees

- The period of the study is for one year.

**PROFILE OF THE COMMERCIAL TAXES DEPARTMENT**

In the Year 1986 the Andhra Pradesh General Sales taxes Amendment Act 1986 was enacted and the amendment contained there in were brought into force with effect on and from 1<sup>st</sup> April 1985.To mobilize additional resources the Andhra Pradesh Tax on Luxuries in Hotel and lodging House Act 1987, was enacted. In the year 1987 the Andhra radish tax on Profession, Calling Employment Act 1987 and the Andhra Pradesh Entry of Goods into local Area tax Act 1987 enacted. In the year 1993 the Andhra Pradesh General Sales tax Amendment Act 1993 was enacted. In the year 1996 the Andhra Pradesh Rural Development ordinance Act 1995 has been issued.



**Territorial Jurisdiction**

The Commercial taxes Department is organized territorially into divisions and circles. The Commercial Taxes Department has 25 Divisions.

Each division roughly coinciding with a head quarter except Hyderabad .The Hyderabad city is made of 5 Division. A division is headed by a Deputy Commissioner. Each division is sub divided into circle. Secundrabad Division is odal division with the following:

- Abids

- Charminar
- Punjagutta
- Begumpet
- Secundrabad

Each division in turn comprise of Circle headed by a Commercial Taxes Officer. Typically, there may be 7 to 9 Circles per division. There are totally 193 Circles in Andhra Pradesh. The Circles of Charminar Division are as follows:

- Afzalgunj
- Charminar





- Begum bazar
- Lord bazar
- Maharajgunj
- Malakpet
- Mehdipatnam
- Nizamshahi Road
- Osmangunj
- Large Ta Payer Unit

### Check Post

All the incoming and out going of the goods ie purchases and sales of goods are monitored at the check posts. The check posts are of two types.

Integrated Check Post

Border Check Posts

#### 1. Integrated Check Post

Integrated Check post is to monitor the incoming and out going of goods that is sales and purchases along with the other department i.e. transport, Mining and Forest department. There are 5 Integrated Check Post in Andhra Pradesh.

#### 2. Border Check Post

Border Check post , where all the incoming and outgoing of good ie Sales and purchases from one state to another state and also within the state are monitored. These check post are located in the state for monitoring the transfer that is sales and purchases of goods. There are 13 Border Check post in Andhra Pradesh.

## ACT PREVAILING IN COMMERCIAL TAXES DEPARTMENT

### Central Sales Tax Act

Central Sales tax Act on interstate transactions and levied on such goods, which operate by choosing the act of sales as the criteria for attracting liability to pay the tax, sales being a central part of concept.

### Andhra Pradesh Value Added Tax Act

Andhra Pradesh Value Added tax Act is general indirect tax assessed and collected on the value added to goods in each business transactions. It is levied on all commercial activities involving manufacturing and trading of goods and services.

### Andhra Pradesh Professional tax Act

The Commercial Taxes Department is the nodal agency, which collected the professional tax due from professionals in the state.

### Andhra Pradesh Entertainment tax Act

Andhra Pradesh Entertainment tax Act shall be levied and paid to the state government, a tax of the amount collected on actual sales of tickets for admission to every show in the respect of entertainment held in the theaters.

### Entry Tax Act

This Act is providing for the levy and collection of tax on entry of certain goods into local areas in the state of Andhra Pradesh.

### Luxury tax Act

The Andhra Pradesh tax on Luxuries in Hotels and Lodging Houses Act 1987 was enacted mainly to mobilize additional resources of the State.

### Horse Racing & Betting Tax Act

This tax is collected on horse racing and on certain form of betting.

### Rural Development Cess Act

This act is to provide for the levy and collection of cess for the rural development in the state.

## COMMERCIAL TAXES DEPARTMENT

The Andhra State comprising parts of the erstwhile Madras province was constituted on October 1st 1953. The Madras General Sales Tax Act, 1939 was made applicable to the New State. The Salient Features of the said scheme were Multi point sales tax on all commodities with a minimum turn over of Rs. 10,000/-An additional single point tax on certain luxury items like motor vehicles refrigerators etc. An exclusive single point sales tax and purchase tax on selected items

Subsequently the Andhra Sales Tax Enquiry committee was appointed by the government and based on its recommendations the following changes were effected. An additional single point tax was levied on fine and super fine cloth A purchase tax was levied on raw tobacco and sales tax on manufactured tobacco The single point tax was extended to agricultural and other commodities The list of goods subjected to additional single point tax was expanded Certain commodities were added to the list of exempted commodities.

In the Andhra Pradesh Region , the Tax Structure was more or less modeled on the Madras pattern with some minor different differences and Sales Tax was levied under the Hyderabad General Sales Tax Act ,1950. After the formation of Andhra Pradesh both the regions of Andhra and Andhra Pradesh were brought under a uniform system of Sales Tax with the enhancement of Andhra Pradesh General Sales Tax Act,1957 w.e.f 15-6-1957 with 79 commodities under single point levy.

In the year 1962 the national council of applied economic research headed by Dr.P.S.Lokanatham popularly called lokanatham committee appointed by the Government reviewed the Sales Tax Structure and made several recommendations the various recommendations accepted by the government were incorporated in the APGST ACT by ACT No.16 of 1963 w.e.f. 1-8-1963 . The additional single point tax





on items listed in schedule 1 was abolished which resulted in regrouping of the schedules . After regrouping the first schedule contained 67 commodities liable to single point tax at the stage of first sale . The second schedule contained 9 commodities liable to single point purchase tax . The third schedule (incorporating Declared Goods) ccts.

In the 1993 in order to mobilize additional resource the Andhra Pradesh General Sales Tax (Amendment) Act 1993 (Act no.13 of 1993) was enacted to levy and collect “ Turnover Tax” on the gross turnover in lieu of additional tax leviable on the net turnover. By introducing the turnover tax all the second and subsequent sales of dealers whose turnover is above Rs.10 lakhs per annum were subjected to turnover tax.

The procedure adopted by the commercial taxes department:

- Registration
- Returns
- Payments
- Inspection
- Assessment
- Demand Collection & Balance
- Internal Audit
- Accountant General Audits

**Computerization in the above system**

The Initiative was taken to computerize the department way back from 1990’s. Initially FOX PRO software was developed by the department. Next they have shifted to Oracle Software. This concept brought some sought of discipline to the mode of recording the data and safe guarding the data. This system prevailed till 31.03.2005 ie till the change of new Act APVAT Act .

**Change Management**

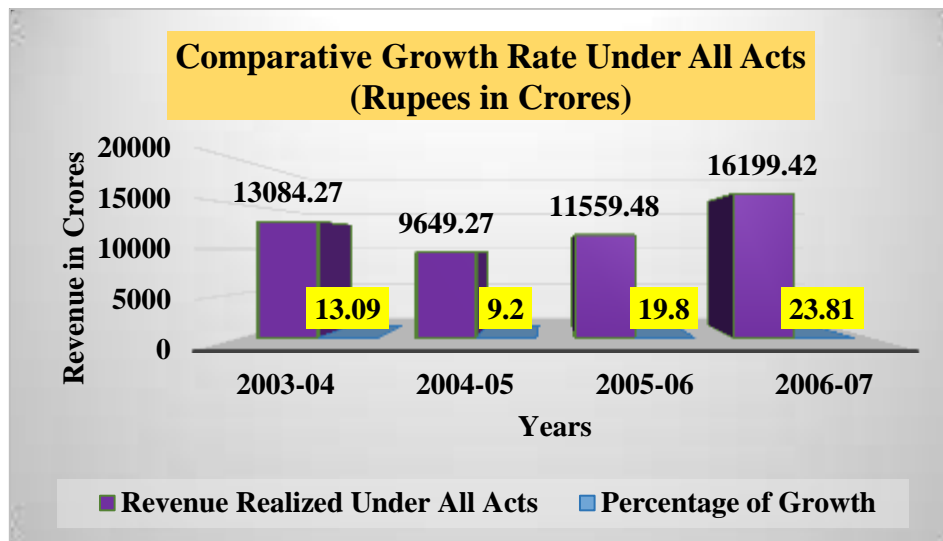
Due to change in the Act with the effect from 01.04.2005 from APGST Act to APVAT Act the entire concept of the act changed drastically. The idea of implementation of the new act with the new software Value Added Tax Information System (VATIS) has indeed shifted the outlook of the department completely to a hi-tech look. This is web-based software where a database and report server is maintained at head office and the application is available to all the circles in state.

This has given a complete change in the look of the New Act APVAT . The registration process was made easy. The return filing has become simpler. Even the dealer is given an opportunity to file his returns online through e-returns. Issue of statutory form is also made available on online to facilitate the dealer the need for the form without delay. The manual system of maintaining the ledgers, demand collection, and balance, cheques and challan register is stopped. The registrations details of the dealers are made available to the dealers as well as the department for cross verification.

The mode of assessment is also simplified as the VATIS software itself verifies and generates the assessment. Cross check reference can be issued in the system. To enable access to various services offered by the department and facilitate effective dissemination of information a dedicated portal is developed. It would provide host of customer friendly features such as e- returns, e-payments, etc. Further it would be linked to all the citizen services centers, which would facilitate payments of taxes and filing of returns at these centers. This would assist in increasing transparency and widening the outreach of government services.

After the Change in the organization that is computerization system also effected the revenue part of the organization.

Comparative Growth Rate Under All Acts (Rupees in Crores)		
Year	Revenue Realized Under All Acts	Percentage of Growth
2003-04	13084.27	13.09
2004-05	9649.27	9.20
2005-06	11559.48	19.80
2006-07	16199.42	23.81



### DATA ANALYSIS

The data has been collected from the respondents who are working in Commercial Taxes Department, through the structured questionnaire. The analysis indicates that 60% of the respondents have service experience of more than 15 years. They think the change is necessary, and is due to technology impact. From the Commercial Taxes Department training was provided to all the staff through internal and external sources. 98% of the respondents were benefited with training Programme. The change in the system has increased the work for the employees, change has no impact on salary, respondents are not facing any difficulty with this change. 68% of the respondents are agreed with the improvement in technical, personnel & competency skills due to change in the working system. Respondents are satisfied with change in the Commercial taxes Department.

To conclude we can say that change may be forced on an organization or an organization in response to the environment or internal need. What ever the case change must be properly planned and members should be properly to accept these changes enthusiastically, because the real world is turbulent, requiring.

### SUGGESTIONS

Now a days the information technology is very important element and need for an organization as well as for individuals. Computerization is necessary in this modern and competitive world. But proper training and maintenance of computer knowledge is important without which it is not beneficial for the department and for individual.

- The employees would be more satisfied if the training provided would be more in details, that training is beneficial for their present as well as for their future.

- It would be more beneficial if training would be provided on effective, practical and in current modernized way by external professionals.
- The whole department would be computerized that will lead to greater good impact on the Commercial Taxes Department's activities as well as the revenue.
- The full infrastructure facilities, internet facility would be provided to the division & circles of the Department & to the staff.
- Department should provide healthy and good atmosphere, monetary benefits, amenities to the staff.

### REFERENCES

1. Ashwathappa.1994. *Organization theory & Behavior*, Himalaya Publications
2. CB Mamoria.1994. *Personel Management Himalaya Publications*
3. CB Gupta.2003. *Human resource Management*, Sultan Chand & Sons
4. L M Prasad.2003. *Organizational theory & behavior Kalyani Publications*
5. Rosy Joshi.2003. *Organizational Theory & Behavior*, Kalyani Publishers
6. B Subba Rao.1999. *Human Resource Management & Industrial Relations*, Himalaya Publishers
7. Sashi K Gupta & Rosi Joshi.2005. *Organisational Theory & Behavior*, Kalyani Publishers.

### Websites

1. [www.apcommercialtaxes.gov.in](http://www.apcommercialtaxes.gov.in)
2. [www.thehindubusinessline.com](http://www.thehindubusinessline.com)

### Journal

1. Darren D Armstrong and Md Saeed .2005. "Change Management in Health Care Settings", *The Indian Journal of Commerce*, Volume 58



2. Kirk Strawser (Head of WIPRO Consultation Services).2009. "marketing Changes", *Business India The Magazine of Corporate World* , issue 804
3. Ashraf.2004. "Changing Course Curriculum to Retain the Edge ", *Indian Journal of Marketing* , Volume 34
4. Saravanan S .2004. " Service Marketing Strategic for the new Millennium in Banking Sector", *Indian Journal of Marketing*
5. Sandhya Mehta .2006. " Human Resource's Role As A Strategic Business partner," *HRD News letter*, Volume 22 , issue 04
6. P Ramlal, N Surakshitha and B Mathews.2006. " Changing Dimensions in HRM " *HRD news letters* Volume 22 issue 05
7. Dr G Ramanaiah.2007. " Emerging Business Scenario in the New Millennium and Challenges " *Volume 23 , issue 03*
8. Mrs Neeraja Guda.2005." *E-Business Trends and Issue* ", *Indian Journal of marketing*, expressed Volume 35



# ENTREPRENEURSHIP EDUCATION AS A TOOL FOR EMPLOYMENT GENERATION AMONG NYSC CORPS MEMBERS IN IBADAN NORTH, OYO STATE

<sup>1</sup>Adedapo AA, <sup>2</sup>Nzei IF

Center for Entrepreneurship and Innovation, University of Ibadan, Ibadan, Nigeria

## ABSTRACT

*Nigeria is a nation that is blessed with both human and natural resources, but larger proportion of the citizens graduates included live in abject poverty and face worsening unemployment. In a bid to mitigate the scourge of poverty and unemployment, previous regimes initiated diverse poverty reductions polices (PRPs), such as National Poverty Eradication Fund (NERFUND), Nigeria Directorate of Employment (NDE), Small and Medium Enterprise Development Agency of Nigeria (SMEDAN) et cetera, with the objectives of boasting industrial production and level of employment thereby checkmating joblessness, hopelessness and cubing crime. Despite the various poverty reductions polices (PRPs), the hydra-monster poverty and unemployment have remained endemic judging by official statistics published by reliable bodies. The failures of previous PRPs precipitated the passionate embrace with Millennium Development Goals (MDGs) and compulsory inclusion of entrepreneurship education in the curricula of the three levels of higher education in Nigeria. This research will examines entrepreneurship education as a tool for employment generation among National Youth Service Corps (NYSC) members in Ibadan North Local Government Area of Oyo State, Nigeria. From the regression analysis it could be summarized that: 1. Capacity building has a significant influence on human capital development; 2. Creativity and innovation have a significant influence on economic development; 3. Skill acquisition has a significant influence on job creation; and 4. Entrepreneurship education has a significant influence on employment generation.*

## BACKGROUND OF THE STUDY

Entrepreneurship is considered to be an important mechanism for economic development through employment, innovation and welfare effects (Schumpeter 1934; Acs and Audretsch 1988; Wennekers and Thurik 1999; Baumol 2002). Entrepreneurship education programmes create high job satisfaction and enhance life status. Higher levels of entrepreneurship education achievement lead to higher earnings and reduce the level of unemployment. Of late, many universities around the world are in the process of strengthening their entrepreneurship education programmes in order to create more young entrepreneurs in the future. This kind of education programme is always being reviewed to ensure the structure of the programme will fit in with the challenges of the world outside.

Youths are valuable asset that contribute significantly to the economic development of any nation. According to Chen et al (2016), many universities and higher education institutions have introduced courses related to entrepreneurship or major in entrepreneurship, for instance, Multimedia University (MMU) has launched a program known as Bachelor of Multimedia (Media Innovation and Entrepreneurship) with Entrepreneurship as a core course. On the other hand, the Malaysian government through the Ministry of Higher Education implemented a policy to enhance the entrepreneurship education programs in higher learning institutions. The Entrepreneurship Development Policy was introduced in 2010 with several strategies. Nordin et al (2015) believes that the introduction of Entrepreneurship Development initiative for Nigerian higher learning institutions will produce graduates with entrepreneurial mindset and increase the number of graduate entrepreneurs besides nurturing entrepreneurial academics and researchers. This strategy is necessary due to the increasing interest of many countries to foster



entrepreneurship culture through university education and trainings as it has been proven that entrepreneurial activities can be spurred through entrepreneurship education and trainings.

Entrepreneurship is not new, and during the past number of years it has gained increased interest and research. This increased interest has emerged for a number of reasons, namely the recognition of the contribution of the small firm sector to economic development and job creation (Sa and Holt, 2019). Much of the economy's ability to innovate, diversify, and create new jobs comes from the small business sector. It is now recognized that development agencies, government departments, educational and training institutions are facing the challenge of how to create an enterprise culture, which will further foster the development of small firms. Many initiatives are in place by development agencies and government institutions, which provide valuable and much needed assistance to the start-up firms in terms of advice and financial assistance. However, if new firm start-ups are to continue to increase, it is necessary to encourage and foster enterprise at an earlier age. This can be effectively actioned through the promotion of enterprise through education (Hörnqvist Maj-Lis, Leffler Eva. 2014).

The National Youth Service Corps (NYSC) was created on 22 May 1973 as an avenue for the reconciliation, reconstruction, and rebuilding of the nation after the civil war. It was established based on decree No. 24 that stated that the scheme was created with a view to the proper encouragement and development of common ties among the youths of Nigeria and the promotion of national unity. The scheme was set up by the Nigerian government to involve Nigerian graduates in nation building and the development of the country.

Corps members (participants in the National Youth Service Scheme) are posted to states other than their state of origin where they are expected to mix with people from different ethnic groups, social and family backgrounds, and learn the culture of the indigenes in the location they are posted to. These actions are aimed at bringing about unity in the country and help the youths appreciate other ethnic groups. There is an "orientation" period of approximately three weeks spent in a military controlled "camp" away from family and friends. There is also a "passing out ceremony" at the end of the three weeks orientation camp after which corp members are posted to their Place of Primary Assignment (PPA). They are expected to work as full-time staff at their PPA with exception of one working day devoted for the execution of community development service. After eleven months at their PPA, corps member are allowed a one month of vacation before their final passing out ceremony where they would be issued certificates of completion.

The Skill Acquisition and Entrepreneurship Development Programme, frequently abbreviated as the SAED policy, is an innovation deployed by the Federal Government through the National Youth Service Corps (NYSC thereafter) towards reducing youth employment to the barest minimum in Nigeria. This is because youth unemployment has become one of the most serious socio-economic problems confronting Nigeria (Ajufu, 2013), and can be a major driver of social vices in the country (Adebayo, 2013; Adewusi and Adisa 2018).

Most graduates are aiming to get high salaries in the public or private sector after graduation. They never realize that there is a sector that would offer them higher income than working in private as well in public sectors. Most of the graduates assumed that entrepreneurship is not suitable for them due to their lack of knowledge on this field. As a result, our youths are focusing on hunting for the best positions in the public and private sectors that are very competitive rather than choosing to become entrepreneurs as a solution in generating income. Besides, there is a situation where these youth have to work hard for their fixed wages even though their salaries do not commensurate with the amount of work that they do. Indeed, becoming an entrepreneur is much better than becoming an employee (Piperopoulos, 2012). To produce successful entrepreneurs is not easy. It needs a lot of effort, determination and commitment to pick up the qualities of entrepreneurs. In fact, a lot of scholars believe that becoming an entrepreneur is a process and youth can be shaped to be one in this industry. The government also realized that entrepreneurship is profiting skills that can help our youth generate not only their own personal income, but also the economic development of the nation. This study is only a guide and a contribution to entrepreneurship knowledge with the hope of strengthening entrepreneurship among the youth. To build the interest of our young generation is a challenge to the government.

Education is the key to national development. This is because it unlocks the economic potentials of the people; empowers and equips individuals in society to participate in, and benefit from their national economy; facilitates economic development and provides the basis for transformation. Education is the essential tool for sustainability. The present global economic crises suggest that the entire world is in a war between financial/qualitative education and catastrophe (Joseph and Esther 2012)

Entrepreneurship education as part of the total educational system is the type of education that involves the acquisition of skills, ideas and management abilities necessary for job creation. An entrepreneur promotes employment rather than seeking for an employment. Therefore, there is a need to embrace this type of education and





provide all the necessary resources needed to make functional. Quality entrepreneurship education could be used as a tool for fighting the war against poverty and unemployment in Nigeria.

For almost a decade now in Nigeria the curriculum of entrepreneurship education has remained un-changed. Worst still is that a single curriculum is used in training undergraduate of all discipline in entrepreneurship. To meet the global challenges the curriculum of tertiary institution needs to be overhauled to take care of some inadequacies.

Emaikwu (2011) argues that institutions of higher learning in Nigeria have concentrated more on theoretical and abstract instructional deliveries focusing only on cognitive development and consequently turning out non-entrepreneurial skilled graduate into labour market. Curriculum experts have attested that there is the need to change from the hangover effects of theoretical liberal academic education, which focused only on cognitive development to the utter neglect of entrepreneurship education that has its focus on practical occupational skills for self-employment and self-reliance. This of course is a problem that policy makers in Nigeria need to tackle if they are to enhance the entrepreneurship culture in the country and increase the entrepreneurial inclination of undergraduate. The ultimate challenge therefore, is for the policy makers to encourage curriculum innovation aimed at producing graduates with the right mind set for starting business of their own and in the same vein motivating other to start-up business for economic reliance.

In particular, entrepreneurship education is a deliberate action that should stimulate the critical thinking of individuals to generate revolutionary and innovative business ideas (Sadeghi et al 2013). Researchers such as Adebayo and Kolawole (2013), Dirk et al (2013) and Papadimitriou (2015) have advocated revising curriculum materials for entrepreneurs in universities to fill the gap between theory and practice, with a clear focus on improving entrepreneurial intentions. Nevertheless, it is necessary to confirm whether the entrepreneurship curriculum stimulates students' critical thinking and the formation of business thinking in Nigerian universities.

In the same vein, pedagogical approaches adopted in entrepreneurial education should create a common vision among university students in order to consider socio-economic problems as problems that can be transformed into viable and sustainable business opportunities (Sahlberg, 2010). Consequently, studies such as Middleton (2010), Aja-Okorie and Adali (2013), and more recently Nasiru et al (2015) on entrepreneurship pedagogical problems in university education have recommended the design of experiential learning things to do to motivate the improvement of creative problem solving abilities in order to enhance students' entrepreneurial intentions. Nevertheless, considering the link between pedagogical approaches and identification of commercial enterprise opportunities, one thing of keen interest particularly in the Nigerian college context that many studies have overlooked is the extent to which the pedagogical approach adopted affect students' shared imaginative and prescient and identification of commercial enterprise opportunities.

Consequently, most of the government efforts to reduce poverty in the country were not tailored towards entrepreneurship education and organization of training for the unemployed people in the society. These problems therefore prompt the need for this research. The objective of this study therefore is to examine the extent of the impact of technical skill on youth empowerment and analyze the relationship between entrepreneurial skill and social welfare service.

The major objective of this study is to evaluate the impact of entrepreneurship education as a tool for employment generation among National Youth Service Corps (NYSC) members in Ibadan North, Nigeria. The sub-objectives however will be to:

1. Determine the extent to which capacity building can affect human capital development among NYSC members in Ibadan North.
2. Evaluate the influence of creativity and innovation on economic development among NYSC members in Ibadan North.
3. Ascertain the effect of skill acquisition and job creation among NYSC members in Ibadan North.
4. Examine the relationship between entrepreneurship education and employment generation among NYSC members in Ibadan North.

## METHODOLOGY

Research design, population of the study, sample size, sampling technique, research instrument, validity and reliability, administration of instrument and method of data analysis were the techniques used in collecting and analyzing the data collected.

**Research design**

For the purpose of this study, the cross-sectional study design was used. The cross-sectional study design method focused on population, through which facts are gotten from a portion (snap-short) of the population using specific techniques of sampling for the purpose of intensive study and analysis.

**Population of the study**

The population of the study explains the area covered for a research work. The population that was used for the gathering of relevant information needed for this research work was a total of 357 NYSC members in Ibadan North Local Government Area of Oyo State.

**Sampling technique**

The method of sampling that was employed is simple random sampling. This is a process of picking some elements from the population in such a way that every element in the population has an equal chance to be picked like any other element in the population.

**Sample size determination**

The sample size is a representative fraction of the larger population. For this research work, sample sizes were determined using Yaro Yemane formula to get the sample size of 357, which was increased to 360 to allow for possible non response and also have adequate number for cross tabulation.

**Operationalization of Research Variables**

X = Independent Variable (Entrepreneurship Education)

Y = Dependent Variable (Employment Generation)

$Y = f(X)$

Where Y = Entrepreneurial Education, X = Employment Generation

$Y = (y_1, y_2, y_3, y_4)$

$y_1$  = Capacity Building (CB)

$y_2$  = Creativity and Innovation (CI)

$y_3$  = Skill Acquisition (SA)

$y_4$  = Entrepreneurship Education (EE)

$X = (x_1, x_2, x_3, x_4)$

$x_1$  = Human Capital Development (HCD)

$x_2$  = Economic Development (ED)

$x_3$  = Job Creation (JC)

$x_4$  = Employment Generation (EG)

**Therefore:**

$Y = f(X)$

$y_1 = f(x_1)$  ..... Equation 1

$y_2 = f(x_2)$  ..... Equation 2

$y_3 = f(x_3)$  ..... Equation 3

$y_4 = f(x_4)$  ..... Equation 4

**Regressionally, we have:**

$y_1 = \alpha_0 + \beta_1 x_1 + \mu$  ..... Equation 1

$y_2 = \alpha_0 + \beta_2 x_2 + \mu$  ..... Equation 2

$y_3 = \alpha_0 + \beta_3 x_3 + \mu$  ..... Equation 3

$y_4 = \alpha_0 + \beta_4 x_4 + \mu$  ..... Equation 4

**Method of data collection**

For the purpose of this study, primary source of data collection was adopted. The primary data was sourced using questionnaire. The questionnaires were distributed directly to the target respondents within the population. The questionnaire were used to assume the anonymity of respondent and therefore given the boldness to fill answers



to questions appropriately (Asika, 2004). All other advantages of questionnaire were fully utilized whilst the shortcomings were guided against so as to make it free from bias and ensure good generalization. In other to guide against the shortcomings, the researcher ensured that the sentences in the questionnaire were not ambiguous.

### **Research Instrument**

Quantitative method of data collection were carried out using structured questionnaire, hence the use of questionnaire was indeed the primary source of data. The questionnaire is made of two parts. Part A was on demographic information of the respondents, while part B was made up of four sections namely A, B, C and D. Section A dealt with questions on capacity building (CB), section B dealt with questions on human capital development (HCD), section C was on questions on creativity and innovation (CI), section D on questions on economic development (ED), section E dealt with questions on skill acquisition (SA), section F on questions on job creation (JC), section G focused on questions on entrepreneurship education (EE) while section H was on questions relating to employment generation (EG).

The modified scale type measurement was adopted in this research work, which tends to measure the concentration of thoughts of the respondent with respect to the information being sought for in the questionnaire. A six point modified rating scale were used and this consisted of 6 = strongly agree (SA), 5 = agree (A), 4 = partially agree (PA), 3 = partially disagree (PD), 2 = disagree (D) and 1 = strongly disagree (SD). Asika (2004) submits that the modified scale type is a rating technique used widely to measure personal characteristics and reflect the extreme positions on a continuum, which enable the respondents to freely indicate their opinion on the structured statement.

### **Validity of the research instrument**

To ensure validity of the instrument, several relevant literatures were reviewed and also the researcher gave the draft of the questionnaire to the supervisor for critical review and screening. The researcher also presented the instrument to experts for assessment, after which it was approved to be administered to NYSC members in the said case study.

### **Reliability of the research instrument**

The reliability of a research instrument concerns the extent to which the instrument yields the same results on repeated trials. Reliability was ensured by conducting a test for validity and reliability using IBM SPSS software version 21.0 was obtained showing that the instrument is reliable as to measuring what it has been designed to measure.

### **Method of data analysis**

The data was analyzed with the use of both descriptive and inferential statistical method. Descriptive statistics such as contingency table, simple percentage value (%) and frequency distribution were considered appropriate for description of variables such as respondent status, category of age, gender group and position occupied. Inferential statistical technique adopted for this study is simple linear regression analysis, which was used to understand the relationship existing among identified variables. Simple linear regression analysis is a statistical method that allows a single explanatory or criterion variable to be examined on a dependent variable (Tarafdar & Gordon, 2010). The rationale for the adoption of simple linear regression analysis was that first; it shows optimal result when the relationship between the independent and dependent variable are almost linear. Just like the name implies, it is simple and less complicated in deriving findings and also interpreting the findings. Simple linear regression technique will be carried out using Statistical Package Social Science (SPSS) 21.0 software for this study.

### **Method of Data Presentation**

The analyzed data were presented in rows, charts and tables.

### **Ethical Consideration**

Ethical considerations were obtained from Ibadan North Local Government Area, and ethics review committee before the study was conducted. Informed consent was sought from participants before administering the questionnaire. Participants were informed that participation in the study is voluntary and information obtained would be confidential.



## DATA ANALYSIS, RESULTS AND DISCUSSION OF FINDINGS

This section of the study consists of the presentation of the data obtained for the study, its analysis based on the different statistical modes, models and methods adopted. The interpretation of the results as well as the discussion of the findings that were obtained as a result of the test of the various hypotheses proposed in line with the paring of variables.

### 1 Response Rate

**Table 1 Response Rate**

Questionnaire	Frequency	Percentage (%)
Distributed	357	
Valid Response	285	80%

Source: Field Survey, 2019

Table 1 gives illustration of the response rate from the NYSC members studied. It shows that 357 questionnaires were distributed, and 285 questionnaires were valid and found relevant for the study giving a response rate of 80%.

**Table 2: Distribution of the Respondents Demographic and Personal Information**

Demographic and Personal Information		Population of Respondents	
Variable	Information	Frequency (N)	Percentage (%)
Gender	Male	113	39.6%
	Female	172	60.4%
Age	Below 25 years	84	29.5%
	26- 30 years	201	70.5%
Marital Status	Single	198	69.5%
	Married	87	30.5%
	Divorced	0	0%
	Widow/Widower	0	0%
Religion	Christianity	151	52.1%
	Islam	134	47.9%
	Traditional	0	0%
Educational Qualification	BSc/HND	285	100%
	MSc/MBA	0	0%
	PhD/DBA	0	0%

Table 42 shows the frequency distribution of respondents' demographic data. A total of 285 valid respondents were recorded as NYSC members in Ibadan North, Oyo State. 39.6% of the respondents were males, while 60.4% of the respondents are females. The age distribution of respondents shows that 29.5% of the respondents were less than 25 years, while 70.5% were within the age of 26-30. The marital status of the respondents shows 198 representing (69.5%) of the respondents are single, while 87 representing (30.5%) of the respondents are married. The religious affiliation of the respondents indicates that 151 of the respondents representing (52.1%) were Christians, while 134 representing (47.9%) were of Muslims. The educational qualification of the respondents shows that 185 being the entire population representing (100%) were B.Sc./HND holders.

**Table 3: Responses according to the research instrument**

S/N	Entrepreneurship Education	SA	A	D	SD
1.	Entrepreneurship education programmes create high job satisfaction and enhance life status and reduce the level of unemployment.	165 57.8%	87 30.5%	20 7.0%	13 4.5%
2.	Universities have strengthened their entrepreneurship education programmes in order to create more young entrepreneurs in the future.	147 51.6%	91 31.9%	37 12.9%	10 3.5%
3.	Entrepreneurship Development initiative for Nigerian higher learning institutions has produced graduates with entrepreneurial mindset and increase the number of graduate entrepreneurs.	123 43.2%	122 42.8%	24 8.4%	16 5.6%
4.	Entrepreneurship education is the key component to national development and sustainability.	202 70.9%	61 21.4%	17 5.9%	5 1.7%
5.	Entrepreneurship education is the key that unlocks the economic potentials of the people; empowers and equip individuals in society.	180 63.2%	72 25.2%	24 8.4%	9 3.1%

Table 3 shows that 165 strongly agreed, 87 agreed that entrepreneurship education programmes create high job satisfaction and enhance life status and reduce the level of unemployment, while 20 disagreed and 13 strongly disagreed. 147 strongly agreed, 91 agreed that Universities have strengthened their entrepreneurship education programmes in order to create more young entrepreneurs in the future. 37 disagreed and 10 strongly disagreed. 123 strongly agreed, 122 agreed that entrepreneurship development initiative for Nigerian higher learning institutions has produced graduates with entrepreneurial mindset and increase the number of graduate entrepreneurs, while 24 disagreed and 16 strongly disagreed. 202 strongly agreed, 61 agreed that entrepreneurship education is the key component to national development and sustainability, while 17 disagreed and 5 strongly disagreed. 180 strongly agreed and 72 agreed that entrepreneurship education is the key that unlocks the economic potentials of the people; empowers and equip individuals in society, while 21 disagreed and 9 strongly disagreed.

**Table 4: Responses according to the research instrument**

S/N	Capacity Building	SA	A	D	SD
6.	Entrepreneurship education provides opportunity for training and capacity building.	136 47.7%	95 33.3%	30 10.5%	24 8.4%
7.	Entrepreneurial training improves capacity in carrying out my entrepreneurial tasks.	118 41.4%	106 37.1%	41 14.4%	20 7.0%
8.	Entrepreneurship education helps to sensitize young graduates and turn them away from certificate frenzy towards becoming opportunity entrepreneurs.	192 67.4%	75 26.3%	10 3.5%	8 2.8%
9.	Entrepreneurship education has equipped me with skills and knowledge needed to perform effectively and efficiently as entrepreneur.	159 55.7%	86 30.2%	26 9.1%	14 4.9%
10.	Entrepreneurship education reveals creative potentials, intellectual capacities and leadership abilities needed in entrepreneurship.	139 48.7%	93 32.6%	32 11.2%	21 7.4%

Table 4 shows that 136 strongly agreed, 95 agreed that entrepreneurship education provides opportunity for training and capacity building, while 30 disagreed, 24 strongly disagreed. 118 strongly agreed, 106 agreed that entrepreneurial training improves capacity in carrying out my entrepreneurial tasks, while 41 disagreed and 20 strongly disagreed. 192 strongly agreed and 75 agreed that entrepreneurship education helps to sensitize young graduates and turn them away from certificate frenzy towards becoming opportunity entrepreneurs, 10 disagreed and 8 strongly disagreed. 159 strongly agreed, 86 agreed that entrepreneurship education has equipped me with skills and knowledge needed to perform effectively and efficiently as entrepreneur, while 26 disagreed and 14 strongly disagreed. 139 strongly agreed, 93 agreed that entrepreneurship education reveals creative potentials, intellectual capacities and leadership abilities needed in entrepreneurship, while 32 disagreed, 21 strongly disagreed.



**Table 5: Responses according to the research instrument**

S/N	Innovation	SA	A	D	SD
11.	Innovation is the greatest source of sustainable growth in every entrepreneurial venture.	161 56.5%	87 30.5%	20 7.0%	17 5.9%
12.	Every growth oriented entrepreneurial venture is a function of innovation.	174 61.0%	72 25.2%	29 10.1%	10 3.5%
13.	Entrepreneurial development serves as catalysis for product differentiation and innovation.	200 70.2%	65 22.8%	5 1.7%	15 5.2%
14.	Through a continual repetition of this dynamic process, as new innovations are introduced in the market wealth changes hands and often changes places.	85 29.8%	172 60.3%	16 5.6%	12 4.2%
15.	The level of innovative product and service awareness depends significantly on entrepreneurs.	105 36.8%	141 49.4%	29 10.1%	10 3.5%

Table 5 shows that 161 of the respondents strongly agreed, 87 disagreed that Innovation is the greatest source of sustainable growth in every entrepreneurial venture, 20 disagreed and 17 strongly disagreed. 174 strongly agreed and 72 agreed that every growth oriented entrepreneurial venture is a function of innovation, 29 disagreed and 10 strongly disagreed. 200 strongly agreed and 65 agreed that entrepreneurial development serves as catalysis for product differentiation and innovation, while 5 disagreed and 15 strongly disagreed. 85 strongly agreed and 172 agreed that through a continual repetition of this dynamic process, as new innovations are introduced in the market wealth changes hands and often changes places, 16 disagreed and 12 strongly disagreed. 105 strongly agreed and 141 agreed that the level of innovative product and service awareness depends significantly on entrepreneurs, while 29 disagreed and 10 strongly disagreed.

**Table 6: Responses according to the research instrument**

S/N	Skill Acquisition	SA	A	D	SD
16.	Entrepreneurship development programme helps one to be creative.	168 58.9%	87 30.5%	23 8.0%	7 2.4%
17.	Entrepreneurship development programme exposes one to entrepreneurship activities and opportunities.	126 44.2%	126 44.2%	22 7.7%	11 3.8%
18.	Entrepreneurship development programme provides opportunity for one to develop oneself in entrepreneurial skill.	181 63.5%	79 27.7%	19 6.7%	6 2.1%
19.	Entrepreneurship development helps me to achieve my goal/ambition and not look for white-collar job.	139 48.7%	90 31.5%	35 12.3%	21 7.4%

Table 6 shows that 168 of the respondents strongly agreed and 87 agreed that entrepreneurship development programme helps one to be creative, while 23 disagreed and 7 strongly disagreed. 126 strongly agreed and 126 agreed that entrepreneurship development programme exposes one to entrepreneurship activities and opportunities, while 22 disagreed and 11 strongly disagreed. 181 strongly agreed and 79 agreed that entrepreneurship development programme provides opportunity for one to develop oneself in entrepreneurial skill, while 19 disagreed and 6 strongly disagreed. 139 strongly agreed and 90 agreed that entrepreneurship development helps me to achieve my goal/ambition and not look for white-collar job, 35 disagreed and 21 strongly disagreed.

**Table 7: Responses according to the research instrument**

S/N	Human Capital Development	SA	A	D	SD
20.	Entrepreneurship development programme provides both managerial and business skills to recipients.	140 49.1%	100 35.1%	35 12.3%	10 3.5%
21.	Entrepreneurship development programme provides communication skills.	169 59.3%	84 29.4%	20 7.0%	12 4.2%
22.	Entrepreneurship development programme provokes in me the ability to perform tasks.	129 45.2%	118 41.4%	30 10.5%	8 2.8%
23.	Entrepreneurship development programme makes me optimistic to have a breakthrough in my line of business.	142 49.8%	97 34.0%	24 8.4%	22 7.7%
24.	Entrepreneurship development programme awakens in me the ability to control events around me to succeed.	109 38.2%	125 43.8%	35 12.2%	16 5.6%

Table 7 shows that 140 strongly agreed and 100 agreed that entrepreneurship development programme provides both managerial and business skills to recipients, while 35 agreed and 10 strongly agreed. 169 strongly agreed and 84 agreed that entrepreneurship development programme provides communication skills, while 20 disagreed and 12 strongly disagreed. 129 strongly agreed and 118 agreed that entrepreneurship development programme provokes in me the ability to perform tasks, while 30 disagreed and 8 strongly disagreed. 142 strongly agreed and 97 agreed that entrepreneurship development programme makes me optimistic to have a breakthrough in my line of business, while 24 disagreed and 22 strongly disagreed. 109 strongly agreed and 125 agreed that entrepreneurship development programme awakens in me the ability to control events around me to succeed, while 35 disagreed and 16 strongly disagreed.

**Table 8: Responses according to the research instrument**

S/N	Economic Development	SA	A	D	SD
25.	Entrepreneurial development helps in economic development and stability.	155 54.4%	112 39.3%	12 4.2%	6 2.1%
26.	Entrepreneurial development provides substitute strategy and hence promote local manufacturer.	131 45.9%	132 46.3%	9 3.1%	13 4.5%
27.	It serves as an incubator for indigenous entrepreneurship development in the Nigerian economy.	164 57.5%	88 30.8%	19 6.7%	14 4.9%
28.	Entrepreneurial development has contributed towards industrial development in Nigeria	136 47.7%	107 37.5%	27 9.4%	15 5.2%
29.	It has contributed optimally towards an increase in GDP/GNP of the Nigerian economy.	138 48.4%	99 34.7%	36 12.6%	12 4.2%

Table 8 shows that 155 strongly agreed and 112 agreed that entrepreneurial development helps in economic development and stability, 12 disagreed and 6 strongly disagreed. 131 strongly agreed and 132 agreed that entrepreneurial development provides substitute strategy and hence promote local manufacturer, while 9 disagreed and 13 strongly disagreed. 164 strongly agreed and 88 agreed that it serves as an incubator for indigenous entrepreneurship development in the Nigerian economy, while 19 disagreed and 14 strongly disagreed. 136 strongly agreed and 107 agreed that entrepreneurial development has contributed towards industrial development in Nigeria, while 27 disagreed and 15 strongly disagreed. 138 strongly agreed and 99 agreed that It has contributed optimally towards an increase in GDP/GNP of the Nigerian economy, while 36 disagreed and 12 strongly disagreed.

**Table 9: Responses according to the research instrument**

S/N	Employment Creation	SA	A	D	SD
30.	Entrepreneurship development programme helps me to become a boss.	126 44.2%	84 29.4%	41 14.4%	33 11.5%
31.	Entrepreneurship development programme guarantees me ownership of business.	179 62.8%	69 24.2%	24 8.4%	13 4.5%
32.	Entrepreneurship development programme guarantees my self-employment.	188 65.9%	75 26.3%	19 6.7%	3 1.0%
33.	Entrepreneurship development programme makes me take calculated risk for my business.	155 54.4%	94 32.9%	26 9.1%	10 3.5%
34.	Entrepreneurship development programme makes me network to increase my market share.	139 48.7%	87 30.5%	34 11.9%	25 8.7%
35.	Entrepreneurship development programme makes one an employer of labour.	166 59.3%	96 33.6%	18 6.3%	5 1.7%

Table 9 shows that 126 strongly agreed and 84 agreed that entrepreneurship development programme helps them to become their own boss, while 41 disagreed and 33 strongly disagreed. 179 strongly agreed and 69 agreed that entrepreneurship development programme guarantees me ownership of business, while 24 disagreed and 13 strongly disagreed. 188 strongly agreed and 75 agreed that entrepreneurship development programme guarantees my self-employment, while 19 disagreed and 3 strongly disagreed. 155 strongly agreed and 94 agreed that entrepreneurship development programme makes me take calculated risk for my business, while 26 disagreed and 10 strongly disagreed. 139 strongly agreed and 87 agreed that entrepreneurship development programme makes me network to increase my market share, while 34 disagreed and 25 strongly disagreed. 166 strongly agreed and 96 agreed that entrepreneurship development programme makes one an employer of labour, while 18 disagreed and 5 strongly disagreed.

### RESTATEMENT AND TEST OF HYPOTHESIS ONE

**Table 10: Model Summary**

Model	R	R Square	Adjusted R Square	Std. Error of the Estimate
1	.454 <sup>a</sup>	.206	.204	2.76525

a. Predictors: (Constant), Capacity Building

**Table 11: ANOVA<sup>a</sup>**

Model		Sum of Squares	df	Mean Square	F	Sig.
1	Regression	563.080	1	563.080	73.638	.000 <sup>b</sup>
	Residual	2163.994	283	7.647		
	Total	2727.074	284			

a. Dependent Variable: Human Capital Development

b. Predictors: (Constant), Capacity Building

**Table 12: Coefficients<sup>a</sup>**

Model		Unstandardized Coefficients		Standardized Coefficients		
		B	Std. Error	Beta	t	Sig.
1	(Constant)	5.762	.452		12.744	.000
	Capacity Building	.445	.052	.454	8.581	.000

a. Dependent Variable: Human Capital Development

## INTERPRETATION

Table 10 above shows a summary of regression model comprising of the value of R, R<sup>2</sup> and Adjusted R<sup>2</sup> equal to 0.454, 0.206, and 0.204 respectively. The results shows that capacity building has significant effect on human capital development amongst NYSC members in Ibadan North, which gave a coefficient of correlation (R) = 0.454 and coefficient of determination (R<sup>2</sup>) of 0.206, which is significant at 0.05 level. The coefficient of determination (R<sup>2</sup>) of 0.206 suggests that capacity building accounted for 20.6% of the variance in human capital development can be predicted by capacity building.

Table 11 also shows that the total overall significance of the regression model produced F value of 73.638, which is significant at 0.05 levels. This implies that the independent variable, which is capacity building, has a significant influence on human capital development. It indicates that statistically, the model applied can significantly predict the changes in human capital development. Therefore, the null hypothesis one (H<sub>01</sub>) which states that capacity has no significant influence on human capital development in Ibadan north, Oyo State, Nigeria is hereby rejected. This conclusion can be confirmed by the correlation coefficient of R 45.5%. Therefore, it is concluded that capacity building has a significant influence on human capital development.

Furthermore, Table 12 shows the linearity of the variables. The finding revealed that holding explanatory variable (capacity building) to a constant, capacity building would be at 5.762. The column labelled "Unstandardized Coefficients" reveals unstandardized regression coefficients for human capital development as 0.454 (t = 12.744, p = 0.000) less than 5% level of significance.

## DISCUSSION OF FINDINGS

From the statistical result of the study, it shows that capacity building leads to human capital development. Capacity building in the context of human capital development implies a dynamic process, which enables individuals and agencies to develop the critical capacities in identifying, analysing and exploiting opportunities (Awogbenle and Iwuamadi 2010).

Capacity building empowers individuals to acquire knowledge and advanced skills that are critical to both individuals and organizational growth. The standard of living of individuals and people around can be enriched through the empowerment human capital through capacity building. It is the planned programmes that will impart skills, which will enable the recipient put the knowledge and skills acquired into productive uses to solve wide range of individual and national problems. Capacity building from the human capital point of view could be explained to mean when people possess the needed knowledge and advanced skills that are critical to individual growth as well as the country's growth and development, it translates into productive action. The capacity needed by any country for sustainable development is primarily dependent on the adequacy and relevance of its entrepreneurship (Duru 2011).



## RESTATEMENT AND TEST OF HYPOTHESIS TWO

**Table 13: Model Summary**

Model	R	R Square	Adjusted R Square	Std. Error of the Estimate
1	.347 <sup>a</sup>	.121	.118	2.91079

a. Predictors: (Constant), Creativity and Innovation

**Table 14: ANOVA<sup>a</sup>**

Model		Sum of Squares	df	Mean Square	F	Sig.
1	Regression	329.306	1	329.306	38.867	.000 <sup>b</sup>
	Residual	2397.767	283	8.473		
	Total	2727.074	284			

a. Dependent Variable: Economic Development

b. Predictors: (Constant), Creativity and Innovation

**Table 15: Coefficients<sup>a</sup>**

Model		Unstandardized Coefficients		Standardized Coefficients	t	Sig.
		B	Std. Error	Beta		
1	(Constant)	6.740	.457		14.748	.000
	Creativity and Innovation	.310	.050	.347	6.234	.000

a. Dependent Variable: Economic Development

## INTERPRETATION

Table 13 above shows a summary of regression model comprising of the value of R, R<sup>2</sup> and Adjusted R<sup>2</sup> equal to 0.347, 0.121, and 0.118 respectively. The results show that creativity and innovation have significant effect on economic development amongst NYSC members in Ibadan North, which gave a coefficient of correlation (R) = 0.347 and coefficient of determination (R<sup>2</sup>) of 0.121, which is significant at 0.05 level. The coefficient of determination (R<sup>2</sup>) of 0.121 suggests that creativity and innovation accounted for 12.1% of the variance in economic development can be predicted by creativity and innovation.

Table 14 also shows that the total overall significance of the regression model produced F value of 38.867, which is significant at 0.05 levels. This implies that the independent variable, which is creativity and innovation, has a significant influence on economic development. It indicates that statistically, the model applied can significantly predict the changes in economic development. Therefore, the null hypothesis two (H02) which states that creativity and innovation has no significant influence on economic development is hereby rejected. This conclusion can be confirmed by the correlation coefficient of R 34.7%. Therefore, it is concluded that creativity and innovation have a significant influence on economic development.

Furthermore, Table 15 shows the linearity of the variables. The finding revealed that holding explanatory variable (creativity and innovation) to a constant, creativity and innovation would be at 6.740. The column labelled "Unstandardized Coefficients" reveals unstandardized regression coefficients for economic development as 0.347 (t = 14.748, p = 0.000) less than 5% level of significance.





## DISCUSSION OF FINDINGS

Creativity and innovation, which is the process of creating and developing ideas, way of operation, products and processes that assist in decreasing economic reliance and increasing independence is essential in economic development. From the result of the above test of hypothesis, the statistical result showed that creativity and innovation have a significant influence on economic development of Nigeria. It therefore means that when individuals and or organization or even a nation engages in creative activities and comes with innovative products and services, which could be exchanged locally or internationally, it keeps the economy a boosted and empowers development (Emeh, 2012).

Innovativeness is an important component in entrepreneurial practice, because it reflects the important means by which entrepreneurs can pursue new opportunities and introduce new product or service. Innovativeness in entrepreneurship can be seen from three different perspectives, which are product innovation, process innovation and organizational innovation (Ediagbonya 2013).

## RESTATEMENT AND TEST OF HYPOTHESIS THREE

**Table 16: Model Summary**

Model	R	R Square	Adjusted R Square	Std. Error of the Estimate
1	.379 <sup>a</sup>	.144	.141	4.24450

a. Predictors: (Constant), Skill Acquisition

**Table 17: ANOVA<sup>a</sup>**

Model		Sum of Squares	df	Mean Square	F	Sig.
1	Regression	855.934	1	855.934	47.510	.000 <sup>b</sup>
	Residual	5098.466	283	18.016		
	Total	5954.400	284			

a. Dependent Variable: Job Creation

b. Predictors: (Constant), Skill Acquisition

**Table 18: Coefficients<sup>a</sup>**

Model		Unstandardized Coefficients		Standardized Coefficients		Sig.
		B	Std. Error	Beta	t	
1	(Constant)	3.652	.761		4.801	.000
	Skill Acquisition	.517	.075	.379	6.893	.000

a. Dependent Variable: Job Creation

## INTERPRETATION

Table 16 above shows a summary of regression model comprising of the value of R, R<sup>2</sup> and Adjusted R<sup>2</sup> equal to 0.379, 0.144, and 0.141 respectively. The results show that skill acquisition have significant effect on job creation amongst NYSC members in Ibadan North, which gave a coefficient of correlation (R) = 0.379 and coefficient of determination (R<sup>2</sup>) of 0.144, which is significant at 0.05 level. The coefficient of determination (R<sup>2</sup>) of



0.144 suggests that skill acquisition accounted for 14.4% of the variance in job creation can be predicted by skill acquisition.

Table 17 also shows that the total overall significance of the regression model produced F value of 47.510, which is significant at 0.05 level. This implies that the independent variable, which is skill acquisition, has a significant influence on job creation. It indicates that statistically, the model applied can significantly predict the changes in job creation. Therefore, the null hypothesis three (H03) which states that skill acquisition has no significant influence on job creation is hereby rejected. This conclusion can be confirmed by the correlation coefficient of R 37.9%. Therefore, it is concluded that skill acquisition has a significant influence on job creation

Furthermore, Table 18 shows the linearity of the variables. The finding revealed that holding explanatory variable (skill acquisition) to a constant, skill acquisition would be at 3.652. The column labelled "Unstandardized Coefficients" reveals unstandardized regression coefficients for job creation as 0.379 ( $t = 4.801$ ,  $p = 0.000$ ) less than 5% level of significance.

## DISCUSSION OF FINDINGS

From the above result, it is evident that the acquisition of entrepreneurial skills enables people to create job for themselves and also for others by extension. Entrepreneurial skills acquisition means the ability, talent or experience of a person to identify opportunities, strategies and execute a task in exploiting the identified opportunity (Ezie 2012). Skills acquisition in job creation is an important component of entrepreneurship to identify opportunities and pursue it, in order to produce new values or economic success. Entrepreneurship is the capacity and willingness to undertake conception, organization, and management of a productive venture with all attendant risks while seeking profit as a reward (Chiekezie et al 2016).

### RESTATEMENT AND TEST OF HYPOTHESIS FOUR

**Table 19: Model Summary**

Model	R	R Square	Adjusted R Square	Std. Error of the Estimate
1	.594 <sup>a</sup>	.353	.351	2.70357

a. Predictors: (Constant), Entrepreneurship Education

**Table 20: ANOVA<sup>a</sup>**

Model		Sum of Squares	df	Mean Square	F	Sig.
1	Regression	1127.650	1	1127.650	154.277	.000 <sup>b</sup>
	Residual	2068.526	283	7.309		
	Total	3196.175	284			

a. Dependent Variable: Employment Generation

b. Predictors: (Constant), Entrepreneurship Education

**Table 21: Coefficients<sup>a</sup>**

Model		Unstandardized Coefficients		Standardized Coefficients		Sig.
		B	Std. Error	Beta	t	
1	(Constant)	4.443	.442		10.051	.000
	Entrepreneurship Education	.630	.051	.594	12.421	.000

a. Dependent Variable: Employment Generation



## INTERPRETATION

Table 19 above shows a summary of regression model comprising of the value of R,  $R^2$  and Adjusted  $R^2$  equal to 0.594, 0.353, and 0.351 respectively. The results show that entrepreneurship education have significant effect on employment generation amongst NYSC members in Ibadan North, which gave a coefficient of correlation (R) = 0.594 and coefficient of determination ( $R^2$ ) of 0.353, which is significant at 0.05 level. The coefficient of determination ( $R^2$ ) of 0.353 suggests that entrepreneurship education accounted for 35.3% of the variance in employment generation can be predicted by entrepreneurship education.

Table 20 also shows that the total overall significance of the regression model produced F value of 154.277, which is significant at 0.05 level. This implies that the independent variable, which is entrepreneurship education, has a significant influence on employment generation. It indicates that statistically, the model applied can significantly predict the changes in employment generation. Therefore, the null hypothesis four (H04) which states that entrepreneurship education has no significant influence on employment generation is hereby rejected. This conclusion can be confirmed by the correlation coefficient of R 59.4%. Therefore, it is concluded that entrepreneurship education has a significant influence on employment generation

Furthermore, Table 21 shows the linearity of the variables. The finding revealed that holding explanatory variable (entrepreneurship education) to a constant, entrepreneurship education would be at 4.443. The column labelled "Unstandardized Coefficients" reveals unstandardized regression coefficients for employment generation as 0.594 ( $t = 12.421$ ,  $p = 0.000$ ) less than 5% level of significance.

## DISCUSSION OF FINDINGS

Form the result of the last hypothesis; it shows that entrepreneurship education is essential in employment generation. Entrepreneurship education is the process or series of activities which aims at enabling an or group of individuals to assimilate and develop knowledge, skills, values and understanding that are not simply related to a narrow field of activity, but which allow a broad range of problems to be defined, analysed and solved. Entrepreneurship education can be on a formal or informal basis. Enterprise training can be a more planned and systematic effort to modify or develop knowledge, skills, etc., through learning experiences to achieve effective performance in an activity or range of activities. The findings of this study corroborate with Anyadike et al, (2012) whose study established positive relationship entrepreneurship education on stimulation of economic growth; employment generation; and empowerment of the disadvantaged segment of the population, which include women and the poor.

From the regression analysis it could be summarized that: 1. Capacity building has a significant influence on human capital development; 2. Creativity and innovation have a significant influence on economic development; 3. Skill acquisition has a significant influence on job creation; and 4. Entrepreneurship education has a significant influence on employment generation.

## CONCLUSION

Entrepreneurship education is very important that there is urgent need for all higher educational institutions in Nigeria to comply with the academic directives to the effect that entrepreneurship be made compulsory for all students of higher education institutions in Nigeria, irrespective of their areas of specialization. This policy decision was based on government awareness of the crucial role of entrepreneurship education and training in fostering employment generation among the teeming youths, economic growth, and wealth creation. Thus, entrepreneurial skills development, goes beyond training and education, it involves a process of human capacities building through formal and or informal training inculcating in the entrepreneur basic skills such as financial skills, technical skills, creative skills, managerial skills, intellectual skills, marketing skills, communication skills and technological skills.

Entrepreneurship training stands out as an alternative to poverty, operating in line with current education policies that prioritize self-reliance, self-employment, job growth and also global awareness. Entrepreneurship training facilitates the learning of the skills needed for gainful and self-employed jobs. As a specialized training program given to students to acquire skills, concepts and management skills and self-employed jobs, it is a panacea for unemployment.

## RECOMMENDATION

From the findings of this study, the following recommendations are given.



- i. Entrepreneurship syllabus in Nigerian universities should also include wide coverage of critical thinking and brain storming workshops that encourage the generation of business ideas.
- ii. Whilst the advantages of vocational education can be improved by successful entrepreneurship education, vocational training itself cannot, as a realistic practice, inspire the creation of viable business ideas. Idea generation discussion exercises therefore should be counted as part of the Entrepreneurship Program in Nigerian universities. It is important given that every company begins with an idea. Business idea development events should be adapted to student curricula and interest in order to encourage active participation.
- iii. Also, there is a need to include elements of the curriculum that are appropriate to talent development, especially as the advancement of natural abilities may influence the type of business ideas generated.
- iv. Entrepreneurship instructors should ensure that their knowledge and expertise are used to inspire students to participate in entrepreneurial education, with a special emphasis on composing a business plan.

## REFERENCES

1. Acs, Z. J., & Audretsch, D. B. (1988). *Innovation in large and small firms: an empirical analysis*. *The American economic review*, 678-690.
2. Adebayo, A., A. (2013). *Youths' Unemployment and Crime in Nigeria: A Nexus and Implications for National Development*. *International Journal of Sociology and Anthropology*, 5(8): 350 –357.
3. Adebayo, O. & Kolawole, J.A. (2013). *The Historical Background of Entrepreneurial Development in Nigeria: Its Gains, Shortcomings and Needful*. *Journal of Emerging Trends in Economics and Management Sciences*, 4(5): 493-500.
4. Adewusi, O., A and Adisa, B., I. 2018. *The Skill Acquisition and Entrepreneurship Development Programme among Corps Members in Ibadan, Nigeria*. *Zaria Sociological Journal*, 5(1): 248 –260.
5. Aja-Okorie, U., & Adali, O. (2013). *Achieving youth empowerment through repositioning entrepreneurial education in Nigerian universities: problems and prospects*. *European Scientific Journal, ESJ*, 9(28).
6. Ajufo, B., I. (2013). *Challenges of Youth Unemployment in Nigeria: Effective Career Guidance as a Panacea*. *African Research Review* 7 (1): 307-321.
7. Anyadike N, Emeh IEJ and Ukah FO (2012): *Entrepreneurship development and employment generation in Nigeria: Problems and prospects*. *Universal Journal of Education and General Studies Vol. 1(4) pp. 088-102*,
8. Awogbenle, A.C. & Iwuamadi, K.C. (2010). *Youth unemployment entrepreneurship development programmes as an intervention mechanism*. *Afr. J. Bus. Manag.* 4(6). Pp. 831-835.
9. Baumol, W. J. (2002). *The free-market innovation machine: Analyzing the growth miracle of capitalism*. Princeton University Press.
10. Chen, C. J., Lin, B. W., Lin, Y. H., & Hsiao, Y. C. (2016). *Ownership structure, independent board members and innovation performance: A contingency perspective*. *Journal of Business Research*, 69(9), 3371-3379.
11. Chiekezie OM, Nzewi HN, Erhinmwionose IA (2016). *Entrepreneurial skill acquisition and job creation in Benin City, Nigeria*. *EPRA International Journal of Economic and Business Review* 4(6): 94-101
12. Dirk, D., Benson, H., & Bruce, M. (2013). *The Roles of Learning Orientation and Passion for Work in the Formation of Entrepreneurial Intention*. *International Small Business Journal*, 31(6):652-676
13. Duru M (2011). *Entrepreneurship Opportunities and Challenges in Nigeria*. *Business and Management Review* 1(1):41-48.
14. Ediagbonya, K. (2013). *The Roles of Entrepreneurship Education in Ensuring Economic Empowerment and Development*. *Journal of Business Administration and Education* 4(1) pp. 35-46.
15. Emaikwu, S. O. (2011). *Integrating entrepreneurship skills acquisition in the university curriculum for national development*. *Journal of Research in Education and Society*, 2(3), 40-48.
16. Emeh, I.E.J. (2012). *Tackling Youth Unemployment in Nigeria: The Lagos State Development and empowerment programs initiatives*, *Afro Asian Journal of Social Schemes*, 3 (3) P.1-30.
17. Ezie, O. (2012). *Youth Unemployment and its Socio-Economic Implications in Nigeria* *Journal of Social Science and Public Policy* vol. 4 pp 47-59.
18. Hörnqvist, M. L., & Leffler, E. (2014). *Fostering an entrepreneurial attitude—challenging in principal leadership*. *Education+ Training*, 56(6), 551-561.
19. Joseph O. O. and Esther A. A. (2012) *Quality Entrepreneurship Education: A Panacea for Job Creation in Nigeria*, *Journal of Resourcefulness and Distinction, Volume 1 No. 1*,
20. Middleton, K.L.W. (2010). *Developing Entrepreneurial Behaviour: Facilitating Nascent Entrepreneurship at the University*. A Thesis submitted at the Division of Management of Organizational Renewal and Entrepreneurship, Department of Technology Management and Economics, Chalmers University of Technology, Gothenburg, Sweden.



21. Nasiru, A., Keat, O. Y., & Bhatti, M. A. (2015). *Influence of perceived university support, perceived effective entrepreneurship education, perceived creativity disposition, entrepreneurial passion for inventing and founding on entrepreneurial intention. Mediterranean Journal of Social Sciences*, 6(3), 88.
22. Nordin, S. K., Baharuddin, K., Kassim, N. A., & Buyong, S. Z. (2015). *Understanding the halal concept and the importance of information on halal food business needed by potential Malaysian entrepreneurs. International Journal of Academic Research in Business and Social Sciences*, 5(2), 170.
23. Papadimitriou, D. (2015). *The role of Planned Behaviour on Entrepreneurial Intention of Greek Business Students. International Journal of Synergy and Research*, 4(1): 23-27
24. Piperopoulos, P. (2012). *Could higher education programmes, culture and structure stifle the entrepreneurial intentions of students?. Journal of Small Business and Enterprise Development*, 19(3), 461-483.
25. Sa C, and Holt C (2019): *Profiles of entrepreneurship students: implications for policy and practice. Education and Training* 61(2):122-135.
26. Sadeghi, M., Mohammadi, M., Nosrati, M., & Malekian, K. (2013). *The role of entrepreneurial environments in university students entrepreneurial intention. World Applied Programming*, 3(8), 361-366.
27. Sahlberg, P., & Oldroyd, D. (2010). *Pedagogy for economic competitiveness and sustainable development. European Journal of education*, 45(2), 280-299.
28. Schumpeter, J. A. (1934). *Change and the Entrepreneur. Essays of JA Schumpeter*.
29. Wennekers, S., & Thurik, R. (1999). *Linking entrepreneurship and economic growth. Small business economics*, 13(1), 27-56.





# PERSONALITY TRAITS EFFECT ON WRITTEN AND PERFORMANCE TASKS: BASIS FOR INTERVENTION PLAN

**Pazangelene A. Villaruben**

*Faculty, Sta. Catalina National High School Extension*

---

## ABSTRACT

*This study was conducted to determine the personality traits of Grade 10 Students in overcoming the summative assessment. Specifically, this research sought to determine the personality traits among the respondents with the use of Eysenck Personality Questionnaire to identify the relationship between student's different personality trait and their academic performance.*

*The research design used in this study was descriptive method of research that utilized quantitative approach in gathering necessary data from the respondents.*

*The respondents were composed of Grade 10 students of Majayjay District, Division of Laguna. The Student were sought to answer the adapted questionnaire to determine their personality traits and to choose their preferred assessment from the checklist of summative assessment prepared by the researcher. Percentage, Mean, Standard Deviation and simple linear regression analysis were applied as statistical test to achieve the objectives. The population of the study was 425 Grade 10 Students; random sampling technique was employed in selecting one hundred thirty-five (135) students from four (4) Junior High School in Majayjay District. The result showed t-value of 17.796 is significant at 0.000 probability level. The F-value of 8.835 is significant with a p-value of 0.004. This means that the students' personality trait is significantly correlated with their scores in the written tasks. However, there is no significant relationship between personality traits and performance task. The performance task F-value of 0.036 is not significant with a p-value of 0.850. It means student personality traits has no significant relation in the academic performance particularly in terms of performance task.*

*Based on the findings of the study, it is concluded that the personality traits of Grade 10 students have significant effect to students written performance task, but does not have significant effect neither have an impact to student's performance task. It was found out that Grade 10 students who are introvert and extrovert both perform excellently in terms of performance task. In terms of written task, introvert students perform excellently, while extrovert students perform very satisfactory. More over most of them had excellent academic performance. According to the overall sample, Grade 10 student's personality traits was not responsible for their low and high academic rating in terms of performance task assessment. On the other hand, their personality traits are responsible for their low and high academic rating in terms of written task.*

*The researcher highly recommends that: every school, both public and private, may make every effort to establish a counseling program unit in which students are enlightened to understand their personality traits, allowing them to become more enthusiastic about their academic activities; parents may not regard introverted students as academically inferior to their extroverted counterparts; rather, they may view the difference in personality traits.; teachers may know how to address the difference in the student's personality traits by giving various form of activities.; and the extrovert students may be provided teaching and learning facilities that help improve their academic performance in terms of written task.*

---

## INTRODUCTION

Performance of students varies from their different personalities. Students who suffer from introversion or extroversion might affect their academic performance and also their development in dealing with their innate talents and skills. Personality plays a crucial role in everybody's life, because it is the source of motivation of every individual. According to Yahaya (2010), the study of personality is important because many people in our society who think that intelligent students have better behavior than other students. But the actual reality is not assumed, all the students in the class have the same good. Deped Secretary Briones (2019) presented the ongoing interventions of the Department that will improve the quality of learning in public school during the Multi-Stakeholder Panel Discussion: PISA and the Challenge of Education Quality in the Philippines held at SEAMEO Innotech on December 4, 2019. Because according to Program for International Student Assessment



(PISA) in the year of 2015 and 2018 mean performance declined and one of the interpretation on the performance of students is “weaker students became weaker and stronger students became stronger.”

In the mentioned result, how the education curriculum addresses this problem. The K-12 curriculum grading system have the highest percentage on the performance task of the students, teachers have their difficulties to motivate other students to work in a group or perform in front of the class because it might affect their grades. The implementation of performance based benefited some students and some were not. Students need to be actively involved in the learning process in able to pass, and need to use their thinking skill in order to complete the task. But how introvert or extrovert students deal with this type of assessment? The system of education must also give focus on developing and knowing the personality of every student because it will lead to a better learning. It is like knowing the causes of a problem and giving the right and best solution in it by making intervention for personality development.

This study aims to determine the student’s personality traits and how it affects their written and performance task in school. Knowing the Personality Traits of students would serve as a guide for teachers to find what needs to be done to support the development of students’ personality. That is why, the researcher deemed it necessary to conduct a research that would determine the student’s personality as well as their preferred assessment. Students should be aware with their personality, it will help them a lot to know what they need to develop and change. Personality traits provide essential integration on how certain individual deal with the people around them. Students must be well oriented with their personality traits.

According to Hazarti (2012) academic motivation is one of the effective factors on learners’ achievement. Learners need to be interested in learning; otherwise, all efforts of the educational system would fail. So, understanding and developing the knowledge about factors that affect academic motivation can help to improve educational performance.

With the Program for International Student Assessment (PISA) results also reflecting the learners’ performance in the National Achievement Test, DepEd recognizes the urgency of addressing issues and gaps in attaining quality of basic education in the Philippines. According to Briones (2019) DepEd will lead this national effort for quality basic education through Sulong Edukalidad by implementing aggressive reforms in four key areas: (1) K to 12 review and updating, (2) Improvement of learning facilities, (3) Teachers and school heads’ upskilling and reskilling through a transformed professional development program; and (4) engagement of all stakeholders for support and collaboration. The mentioned reform in K to 12 review and updating must take into account. Address the problem in educational system and as well as the problem encountered by the students in applying what they have learned.

Individual academic performance may greatly influence by an individuals’ personality type (Abott & Chell, 2011). Despite of this influence school must show their attention in dealing with the needs of students to improve their academic performance.

This study will serve as an opening eye to teachers and students, it will help them to be oriented enough to know the reason behind their action and behavior. And to determine the preferred assessment based on their personality, and how it will help the student to work in a group or to work with themselves.

## RESEARCH METHODOLOGY

This study employed quantitative method research design in gathering necessary data. The descriptive method of research was used in the study for the reason that it fits in determining the personality traits of Grade 10 Students.

According to Sevilla et.al (2010) descriptive method is used to describe the nature of the situation as it exists at the time of the study and to explore the causes of the particular problem. On the other hand, Calderon (2010) cited that descriptive method focuses at present condition. I used descriptive method in my study to determine what is personality traits of Grade 10 students in learning Araling Panlipunan. This subject involves activities that may vary the interest of students and in the present condition of the Philippines who is facing pandemic. It will be helpful in determining what is the best assessment to be use to assess the learning of the students.

Descriptive research design ideas concern with describing characteristics of the population. It tries to find out the association of a certain characteristics in population. It seeks what matters than product relations and is a method that simplify books with intense accuracy of the phenomena of the moment. Catane, (2010) In line with this, the researcher tended to assess the academic performance while dealing with process of determining whether there is a significant relation between personality traits and academic performance of Grade 10 students.

The respondents of the study consisted of Grade 10 students of Majayjay District. Grade 10 Students were included in the study with the total population of one hundred thirty-five (135) because they were



the ones who can give a clear picture of how personality traits influence their academic performance because they were old enough and encountered different assessment for the past three years in Junior High School. The study was limited to Grade 10 students of Majayjay District and was consist of the following schools: Sta.Catalina Integrated National High School, Suba National High School, Sta.Catalina National High School Extension and Suba National High School Annex.

The researcher used the simple random sampling to Grade 10 Students of Majayjay District, GAS strand, residents of Sta.Catalina Integrated National High School selected the seventy-two (72) Grade 10 Students, Sta.Catalina National High School Extension selected the fifteen (15) Grade 10 Students, Suba National High School selected the thirty-three (33) Grade 10 Students and Suba National High School Annex selected the fifteen (15) Grade 10 Students. With the total of one hundred thirty-five (135) Grade 10 Students of Majayjay District.

Grade 10 Students were chosen by the researcher because they can decide if the personality mentioned in the questionnaire is appropriate with their doings. And as the mentioned statement in chapter 1, Grade 10 students already experienced variety of assessment tool. Therefore, they were in the best position to furnish the researcher with the information needed to answer the research question of this study. The researcher used four different kinds of instruments to collect the required data for the study. The students were first asked to fill out the modified questionnaire of Peter Shepherd (2013) in his study of Know your own mind. This questionnaire was based on the well-proven EPQ or also known as Eysenck Personality questionnaire. It provides the tools for a wide-ranging analysis of your personality, so you can know yourself better, it covers the areas of introversion/Extroversion. Secondly, the respondents answered the self-made checklist of the researcher about the preferred assessment. Thirdly, the students were provided with the necessary amount of data in the questionnaire (written and performance assessment result from 1<sup>st</sup> quarter). Lastly, they were observed in the classroom setting to see if the results of the questionnaire were supported by the reality in the classroom. The instruments in the course of data collection procedure are the following:

The researcher modified the Personality questionnaire, to be easily use by the respondents and as well as by the researcher. It was shorter but the researcher observed carefully that the slight changes won't affect the result of the study. The questionnaire covers Dichotomous Question – questions that make respondents answer with a simple “yes” or “no. According to Allen (2017) One popular and often-used format is a dichotomous question that provides only two possible answers. This type of question is especially prominent in educational assessments. The question becomes a closed-ended question because the choices are supplied by the investigator. Next, there is a Checklist of preferred assessment of introvert/extrovert students and result of written and performance task assessment.

In the quantitative data collection, the researcher administered the Personality Questionnaire to the Grade 10 Students of Majayjay District to determine if the students were experiencing introversion or extroversion. And after administering the Personality Questionnaire, the checklist of assessment was given to determine the preferred assessment of introvert and extrovert students. The table for the result of written and performance task assessment were included in the checklist of assessment. After collecting the necessary data, descriptive and inferential statistics were administered. It included the data summary gathered from the respondents with the use of tables and text to explain what the chart and tables were showing. The integration of quantitative result covers the interpretation and explanation of quantitative result as well as determining the relationship between independent and dependent variable. After the mentioned procedure, the intervention plan was plot to address the problem encountered by introvert and extrovert students.

## STATISTICAL TREATMENT

The following statistical tools were used in treating the data gathered by the researcher.

Statement of the Problem	Statistical Treatment
1. What is the personality traits of Grade 10 students in terms of: Activity; Sociability; Risk-taking; Impulsiveness; Expressive; Reflectiveness; and Responsibility.	Frequency and Percentage
2. What is the preferred assessment of Grade 10 Students: Written Task; and Performance Task	Frequency and Percentage
3. What is the level of Performance in terms of: Written Task; and Performance Task?	Weighted Mean and Standard Deviation



4. Is there a significant relationship between personality traits such activity, sociability, risk-taking, impulsiveness, expressiveness, reflectiveness and responsibility; and result of summative assessment in terms of written and performance task?	Simple Linear Regression Analysis
---	-----------------------------------

## RESULTS AND DISCUSSIONS

### Student's Personality Traits

**Table 1. Frequency Distribution on the Summary of Students' Personality Traits**

Personality Trait	Frequency	Percentage
Extrovert	106	78.52%
Introvert	29	21.48%

Typically, learners fall into two large groups extrovert and introvert. Out of one hundred thirty-five students (135), one hundred six (106) were extrovert and twenty-nine (29) were introvert.

As the table shown above most of the students fall into the personality trait of being extrovert. Extrovert learners have the following characteristics very outgoing, quite comfortable working in and being part of large crowds, have a wide base of friends, enjoy getting to know a lot of people, dive in without always thinking through, feel sapped when spending too much time alone. Extroverted learners possess a social learning style. In addition, they have acute verbal learning styles as well, often communicating through stories or being first to volunteer for assignments and projects.

On the other hand, introverts generally have a shy nature, and students who are Introverted have a solitary learning style, as they often prefer to solve problems on their own. Introverted learners like to brainstorm and seek theoretical exploration. They like to think out a problem and weigh options before moving forward. Introverted learners have the following characteristics; appear reflective or reserved, slow to take action, have a very small but close group of friends because they prefer to get to know a few people really well, feel most comfortable doing things alone and prefer doing things that can be done alone, often likes the idea of things better than the actual thing and finds spending time in large crowds or groups to be exhausting. This is based on the article posted in the website of Our Lady of the Lake University (2021).

### Students' Preferred Assessment as to Written and Performance Task

**Table 2. Students' Preferred Assessment as to Written and Performance Task**

Forms of Assessment	Yes		No	
	f	%	f	%
1. Comic Strip	76	56.3	59	43.7
2. Survey	86	63.7	49	36.3
3. Essay writing	76	56.3	59	43.7
4. Journal review	46	34.1	89	65.9
5. Journal writing	46	34.1	89	65.9
6. Script writing	59	43.7	76	56.3
7. Reported speech	47	34.8	88	65.2
8. Debates	53	39.3	82	60.7
9. Dialogue	59	43.7	76	56.3
10. Tableaus	33	24.4	102	75.6
11. Role Play	84	62.2	51	37.8
12. Letter writing	88	65.2	47	34.8
13. Drawing	87	64.4	48	35.6
14. Campaigns	60	44.4	75	55.6
15. Collages	83	61.5	52	38.5
16. Compositions	73	54.1	62	45.9
17. Multimedia productions	60	44.4	75	55.6
18. Portfolios	85	63.0	50	37.0



19. Research Project	78	57.8	57	42.2
20. Interviews	74	54.8	61	45.2
21. Panel Discussions	41	30.4	94	69.6
22. Presentations	79	58.5	56	41.5
23. Project Making	100	74.1	35	25.9
24. Speech delivery	48	35.6	87	64.4
25. Story telling	77	57.0	58	43.0
26. Case Study	53	39.3	82	60.7
27. Article Review	56	41.5	79	58.5
28. Diorama	34	25.2	101	74.8
29. Poster & Slogan Making	91	67.4	44	32.6
30. Map Construction	52	38.5	83	61.5
31. Reflection Paper	76	56.3	59	43.7
32. News Writing	62	45.9	73	54.1
33. Reaction Paper	74	54.8	61	45.2
34. Community Involvement	51	37.8	84	62.2
35. Issue-awareness campaigns	39	28.9	96	71.1
36. News Reporting	50	37.0	85	63.0
37. Simulations	67	49.6	68	50.4
38. Implementation of Action Plan	102	75.6	33	24.4
39. Content Creator (Tiktok, Youtube)	61	45.2	74	54.8
40. Expressing their feelings through art activities	79	58.5	56	41.5

The table shows the result of the preferred assessment of Grade 10 students. The researcher prepared forty (40) forms of assessment and as a result, here below are the top 10 most preferred assessment of Grade students;

The form of assessment like expressing their feeling though art activities (58.5%), role plays (62.2%), survey (63.7%), project making (74.1%) and implementation of action plan (75.6%) are most likely the type of activities that extrovert students want. While the reflection paper (56.3%), collages (61.5%), making portfolios (63.0%), letter writing (65.2%) and poster/slogan (67.4%) were most likely the type of activities that introvert students want.

The researcher wants to determine their preferred assessment as a tool for the intervention plan of this study. It will be a great help how student develop their performance using the form of activity that they want.

### Level of Pupils' Academic Performance

**Table 3. Level of Students' Performance in Written Task**

Group	Lowest score	Highest score	Mean score	Standard deviation	Remarks
Extrovert	14	40	30.00	6.00	Very Satisfactory
Introvert	20	40	32.00	5.00	Excellent

**Legend:**

- 32.00 – 39.99 *Excellent (E)*
- 24.00 – 31.99 *Very Satisfactory (VS)*
- 16.00 – 23.99 *Satisfactory (S)*
- 8.00 – 15.99 *Fair (F)*
- 0.00 – 7.99 *Needs Improvement (NI)*





The extrovert students showed *very satisfactory* performance in written tasks ( $M=30.00$ ,  $SD=6.00$ ) while the introvert students exhibited *excellent* performance in written tasks ( $M=32.00$ ,  $SD=5.00$ ). The scores of the introvert students in the written tasks is less dispersed than those of the extrovert students, based on the computed standard deviation.

The introvert performs excellently in terms of written task because they are aware of other people and how they are feeling. Introverts are able to imagine themselves in other people's shoes more easily than extroverts. This makes it easier to create fictional characters and to write about their own feelings.

As Cross & Chipman (2015) stated, introverts love to listen and write their ideas and feelings in a piece of paper rather than to perform or express it in front of other people, while extroverts admire to perform and talk in front. Introvert students build a strong bond of friendship, it takes a lot of time to gain their trust, but they will surely form a deep connection with you and your intuition once you gain their trust. Extroverted students make a lot of friends easily but the relationship is not deep like with introverts.

In Jahanbazi's (2013) investigation in Iran found out that in writing activities or task, introverts are more successful than extroverts.

In the study of Muza (2020) the result of the finding revealed that, extroversion and academic performance are not related, because extroversion made students to have more interest in social activities than academic activities. The finding shows that; introversion is correlated to academic performance. Indicating that, introvert students pay attention to their studies through hard-working and seriousness. There is also significant difference between academic performance of extrovert and introvert students. From the results of the findings, there is difference between the academic performance of extrovert and introvert students in English language and Mathematics. This shows that introverted students are better in academic performance than their extroverted counterpart.

In this time of pandemic, introvert have a great chance to showcase their ability to take task seriously. They can focus on their assigned task because they are all at home. And extrovert students find it hard to express their thought and ideas to writing and task given to them.

**Table 4. Level of Students' Performance in Performance Task**

Group	Lowest score	Highest score	Mean score	Standard deviation	Remarks
Extrovert	22	60	49.00	9.00	Excellent
Introvert	38	60	50.00	7.00	Excellent

**Legend:**

- 48.00 – 59.99 *Excellent (E)*
- 36.00 – 47.99 *Very Satisfactory (VS)*
- 24.00 – 35.99 *Satisfactory (S)*
- 12.00 – 23.99 *Fair (F)*
- 0.00 – 11.99 *Needs Improvement (NI)*

The extrovert and introvert students showed excellent performance in performance task. Extrovert got ( $M=49.00$ ,  $SD=9.00$ ) while the introvert got ( $M=50.00$ ,  $SD=7.00$ ). Based on the computed value both extrovert and introvert students excel in performance task. It shows that introvert can also do well the same with extrovert in terms of performance assessment.

In the study of Veysel (2015) When a less anxiety environment is created for introverts during the cognitive process, they can be as efficient as extroverts while processing and storing multiple inputs. In terms of memory capacity, introverts' lack of sufficient short-term memory capacity leads to difficulties in language performance.

In terms of performance task, both introvert and extrovert did excellently. As stated above, if introvert student experiences less anxiety they can perform as extrovert level. That might be reason why introvert and extrovert got the same rating. And on of the factor that we consider, since we are in the midst of pandemic, introvert students became more focus because they are working on their home.



**Table 5. Regression on the Students' Personality Traits and their Academic Performance**

	Written	Performance
Beta coefficient	0.829	-0.086
t-value	17.796, p=0.000	-0.188, p=0.850
Adjusted R-square	0.052	-0.007
F-value	8.385, p=0.004	0.036, p=0.850
Analysis	<i>Significant</i>	<i>Not significant</i>

This table shows the estimated relationship between student's personality traits and their academic performance. It utilized to assessed the strength of the relationship between the two variables.

The students' personality traits were used to estimate their written and performance tasks. For written tasks, the beta coefficient of 0.829 indicates that for every standard unit increase in the students' personality there is a corresponding standard unit increase in their written task. The t-value of 17.796 is significant at 0.000 probability level. The F-value of 8.835 is significant with a p-value of 0.004.

This means that the students' personality trait is significantly correlated with their scores in the written tasks. The adjusted R-square value indicates that 5.2% of the variation in the students' score in the written task is explained by their personality trait.

The result shows that in terms of written task, extrovert and introvert students perform differ. It shows that introvert outcast extrovert in written task. According to John the Peregrine (2013), to extroverts an activity that doesn't involve action nor physical activity, just sitting alone and reading books is a nightmare. But to introverts, reading and sitting down for hours gives a heaven feeling for them. And Bartol & Bartol (2012) also stated that introverts were interested to work on their own rather than in a group. Reading, writing, listening to music, drawing, writing a reflection paper about the movie and using computers are the activities that give pleasure to them. They are more interested in self-reflecting, to be more focus and peaceful while arranging their thoughts on their own.

However, it was found that personality traits do not correlate with the students' scores in the performance task. The performance task F-value of 0.036 is not significant with a p-value of 0.850. It means student personality traits has no significant relation in the academic performance particularly in terms of performance task.

In the study of Muza (2020) the result of the finding revealed that, extroversion and academic performance are not related, because extroversion made students to have more interest in social activities than academic activities. The finding shows that; introversion is correlated to academic performance. Indicating that, introvert students pay attention to their studies through hard-working and seriousness. There is also significant difference between academic performance of extrovert and introvert students. From the results of the findings, there is difference between the academic performance of extrovert and introvert students in English language and Mathematics. This shows that introverted students are better in academic performance than their extroverted counterpart.

The obtained result show why introvert got a high score in written task. Because Introvert students enjoy and love to express their thoughts and ideas through writing. But in terms of performance task, their personality doesn't have significant relation on it. Introvert and extrovert can do both excellently in terms of performance task. Therefore, whether you have introvert or extrovert personality it will not affect your performance task rating. We cannot always control the various aspects of the educational system; be we do have control of our personality. To that end, we have a tremendous influence on our students.

## CONCLUSION

Based on the findings of the study, it was concluded that the personality traits of Grade 10 students have significant effect to students written performance task, but does not have significant effect neither have an impact to student's performance task. It was found out that Grade 10 students who are introvert and extrovert both perform excellently in terms of performance task. In terms of written task, introvert students perform excellently, while extrovert students perform very satisfactory. More over most of them had excellent academic performance. According to the overall sample, Grade 10 student's personality traits was not responsible for their low and high academic rating in terms of performance task assessment. On the other hand, their personality traits are responsible for their low and high academic rating in terms of written task.



## RECOMMENDATION

Based on the conclusions drawn, the following recommendations are offered:

1. Every school, both public and private, should make every effort to establish a counseling program. unit in which students will be enlightened to understand their personality traits, allowing them to become more enthusiastic about their academic activities.
2. Parents should not regard introverted students as academically inferior to their extroverted counterparts; rather, they should view the difference in personality traits.
3. Teachers should know how to address the difference in the student's personality traits by giving various form of activities.
4. The extrovert students should be provided teaching and learning facilities that will improve their academic performance in terms of written task. There will be set of activities that need to be practice by extrovert student, it will help them to focus on written task.

## REFERENCES

1. Abali, Funda (2013) *The Effect of Personality Traits Extroversion/ Introversion On Verbal And Interactive Behaviors Of Learners (Department of Teaching English as a Foreign Language Bilkent University Ankara) August 2012*
2. Adjei, A., Dontoh, S., & Boateng, F. (2018). *The Relationship between the Academic Performance of Extroverts and Introverts in Offinso College of Education on Teacher-Trainees*. RA Journal Of Applied Research, 4(08), 1916-1932.
3. Alastair, S. (2013). *Personality and Second Language Learning*. Asian Social Science, 4(11).
4. Allen, Mark (2017) *The SAGE Encyclopedia of Communication Research Methods*. <https://dx.doi.org/10.4135/9781483381411>
5. Aviv Weinstein (2016) *Volume 3: General Processes and Mechanisms, Prescription Medications, Caffeine and Areca, Polydrug Misuse, Emerging Addictions and Non-Drug Addictions, Pages 993-1007*
6. Barkley, Russell (2016) "Inhibition" *Cognifit* <https://www.cognifit.com/science/cognitive-skills/inhibition>
7. Bartol & Bartol (2012). *Criminal behaviour: A psychosocial approach*. (8th ed.) Upper Saddle River, New Jersey.
8. Briones, Leonor (2019) *Multi-Stakeholder Panel Discussion: PISA and the Challenge of Education Quality in the Philippines held at SEAMEO Innotech on December 4*. <https://www.deped.gov.ph/2019/12/05/deped-chief-issues-directives-to-address-the-challenge-of-quality-in-basic-ed/>
9. Briones, Leonor (2020) *DepEd: PISA, a guide towards Philippine global education transformation PASIG CITY, February 5, 2020* <https://www.deped.gov.ph/2020/02/05/deped-pisa-a-guide-towards-philippine-global-education-transformation/>
10. Cain, Susan A. (2017) *Quiet: The Power of Introverts in a World That Can't Stop Talking Common Sense Media*. All rights reserved. Common Sense and other associated names and logos are trademarks of Common Sense Media, a 501(c)(3) nonprofit organization (FEIN: 41-2024986) Retrieved from <https://www.common sense.org/education/articles/5-classroom-strategies-that-help-introverts-and-extroverts-do-their-best-work>
11. Callahan, S. (2013). *Responding to the invisible student*. *Assessing Writing* 7.1, 57-77
12. Chamorro-Premuzic, T., Furnham, A., & Ackerman, P. L. (2012). *Incremental validity of the Typical Intellectual Engagement scale as predictor of different academic performance measures*. *Journal of Personality Assessment*, 87(3), 261-268.
13. Connie, Stemmler S. (2019) "What is responsibility?" <https://www.developgoodhabits.com/personal-responsibility/>
14. Cresswell JW, Plano Clark VL. *Designing and conducting mixed method research*. 2nd Sage; Thousand Oaks, CA: 2011. [https://scholar.google.com/scholar\\_lookup?title=Designing+and+conducting+mixed+method+research&author=JW+Cresswell&author=VL+Plano+Clark&publication\\_year=2011&](https://scholar.google.com/scholar_lookup?title=Designing+and+conducting+mixed+method+research&author=JW+Cresswell&author=VL+Plano+Clark&publication_year=2011&)
15. DepED (2015) *Policy Guidelines on Classroom Assessment for K + 12 Basic Education Program (DepEd Order No. 8, s. 2015)*
16. Fox, N. A., Schmidt, L. A., Rubin, K. H., & Coplan, R. J. (2011). *The role of frontal activation in the regulation and deregulation of social behaviour during the preschool years*. *Development and Psychopathology*, 8, 89-102. 30.
17. Fox, N. A., Schmidt, L. A., Rubin, K. H., & Coplan, R. J. (2011). *The role of frontal activation in the regulation and deregulation of social behaviour during the preschool years*. *Development and Psychopathology*, 8, 89-102.
18. Furnham, A., & Medhurst, S. (2011). *Personality correlates of academic seminar behaviour: Personality and Individual Differences*, 19, 2011208.
19. Gosling, S. (2011). *Snoop*. New York: Basic Books.
20. Hardin, Brett C. (2016) "The Four Different Personality Types" *Constant Learning Site*. Retrieve from <https://blog.brethard.in/the-four-different-personality-types-9366bfefde16>
21. Hayes, Adam (2021) "Simple Random Sample." *Investopedia Updated Mar 30, 2021 Retrieved from* <https://www.investopedia.com/terms/s/simple-random-sample.asp>
22. Hazarti, Viari (2012) "The effect of personality traits on academic performance: The mediating role of academic motivation" "1877-0428 © 2012 Published by Elsevier Ltd. Selection and/or peer-review under responsibility of the 4th International Conference of Cognitive Science doi: 10.1016/j.sbspro.2012.01.055
23. Hazrati-Viari, A., Rad, A. T., & Torabi, S. S. (2012). *The effect of personality traits on academic performance: The mediating role of academic motivation*. *Procedia-Social and Behavioral Sciences*, 32, 367-371



24. Hazrati-Viaria, Ali Tayarani Rada, Sayed Saeed Torabibi(2011) *The effect of personality traits on academic performance: The mediating role of academic motivation. 4th International Conference of Cognitive Science (ICCS 2011) Procedia - Social and Behavioral Sciences 32 (2012) 367 – 371*
25. Helgoe, Laurie (2011). *Introvert power: Why your inner life is your hidden strength*. Naperville, Illinois: Sourcebooks, Inc.
26. Hire Success (2020) “Cautious vs. Risk-Taking Personality Traits” *Hire Success 3815 River Crossing Pkwy Ste 100 Indianapolis, IN 46240. 08, January,2020. Retrieved from <https://www.hiresuccess.com/help/cautious-vs-risk-taker-personality-types-at-work>*
27. Jahanbazi, M. (2013). *The relationship between extroversion/introversion and writing ability of Iranian EFL learners. Unpublished MA thesis, University of Tehran, Iran.*
28. Kendra,Cherry (2020) *How Extroversion in Personality Influences Behavior. <https://www.verywellmind.com/what-is-extroversion-2795994>*
29. Komarraju, M., & Karau, S. J., Schmeck, R. R. (2011). *Role of the Big Five personality traits in predicting college students' academic motivation and achievement. Learning and Individual Differences, 19, 47–52.*
30. Laidra, K., Pullmann, H., & Allik, J. (2013). *Personality and intelligence as predictors of academic achievement: A cross-sectional study from elementary to secondary school. Personality and Individual Differences, 1-11.*
31. Laney, Martin Olsen (2012). *The introvert advantage: How to thrive in an extravert world*. Workman Publishing
32. Layeghi, F. (2011). *Form and content in the argumentative writinof extroverted and introverted Iranian EFL learners. Iranian EFL Journal 7.3, 166–183.*
33. Lounsbury, J. W., Tatum, H., Gibson, L. W., Park, S. H., Sundstorm, E., Hamrick, F., & Wilburn, D. (2013a). *The development of a big five adolescent personality scale. psychoeducational assessment, 21, 111-133.*
34. Lukas, J. F. & Lukas, J. A. (2015). *Pardon me—your personality is showing! Paper presented at PMI® Global Congress 2015—North America, Orlando, FL. Newtown Square, PA: Project Management Institute. <https://www.pmi.org/learning/library/personality-influences-way-address-challenges-6674>*
35. Mansourinejad, A., Bijami, M., & Ahmadi, M. R. (2012). *Do personality traits predict academic writing ability? An EFL case study. English Linguistics Research 1.2, 145–152*
36. Marsh, H., Byrne, B., &Shavelson, R. (2012). *A multi-faceted academic self –concept: Its hierarchical structure achievement. Journal of Educational Psychology, 80, 366-380.*
37. Miller,Ashley (2017) *What Are the Benefits of Having Sociability Traits in the Workplace? Copyright 2021 Leaf Group Ltd. / Leaf Group Media, All Rights Reserved. Retrieved from <https://careertrend.com/info-8319760-effects-long-work-hours.html>*
38. Mizne, David( 2019) “Who Performs Better At Work, Introverts Or Extroverts?” *15FiveBlog Retrieved from <https://www.15five.com/blog/performs-better-work-introverts-extroverts/>*
39. Morejon,Mike D. (2019) “The 8 Types of Risk-Takers” *THE PROLLANCE PROMISE. Retrieved from <https://drmikemd.com/the-8-types-of-risk-takers>*
40. Musa,S.H(2020) *International Journal of Advanced Academic Research | Arts, Humanities and Education| ISSN: 2488-9849 Vol. 6, Issue 4 (April 2020)*
41. Northouse, P. (2016). *Leadership Theory and Practice (7th ed). Thousand Oaks, CA: SAGE Publications, Inc Retrieved from <https://sites.psu.edu/leadership/2019/09/29/sociability-and-leadership-effectiveness/>*
42. Our Lady of the Lake University (2021) *Learning Styles of Introverts and Extroverts (1 S.W. 24th St.San Antonio, Texas 78207) 855-275-1082 Retrieved from <https://onlineprograms.ollusa.edu/ma-in-counseling/resources/learning-styles-of-introverts-and-extroverts>*
43. Parker,Vanessa (2015) “4 Personality Types that all Leaders Should Learn to Recognize” *Crestcom. <https://crestcom.com/blog/2015/11/24/4-personality-types-that-all-leaders-should-learn-to-recognize/>*
44. Peregrine, John (2013) *A kingdom for the Introvert-Tapa Banda CreateSpace Independent Publishing Platform; First edition (February 10, 2013)*
45. Piscone,Deborah P. (2015) “The 7 Characteristics of Bold Risk-takers” *Linked in 2020. Retrieved from <https://www.linkedin.com/pulse/7-characteristics-bold-risk-takers-deborah-perry-piscione>*
46. Poropat, A. E. (2011). *A meta-analysis of the five-factor model of personality and academic performance. Psychological Bulletin, 135, 322–338.*
47. Priti, Arun(2016) *Neuropathology of Drug Addictions and Substance Misuse, 978-0-12-800634-4*
48. Rabae, Salini (2014) *Faculty of Technical and Vocational Education Universiti Tun Hussein Onn Malaysia, 86400 Batu Pahat, Johor (Influence of Personality on Academic Achievement and Performance of Teaching Practices Students in TVET) Vol.4, No.16, 2014*
49. Robinson R.S. (2014) *Purposive Sampling. In: Michalos A.C. (eds) Encyclopedia of Quality of Life and Well-Being Research. Springer, Dordrecht. [https://doi.org/10.1007/978-94-007-0753-5\\_2337](https://doi.org/10.1007/978-94-007-0753-5_2337)*
50. Sheperd, Peter (2015) *1994-2003 Tools for transformation WWW: <http://www.trans4mind.com> (Know your mind – Personality Questionnaire)*
51. Skehan, P. (2013). *Individual differences in second-language learning. London: Erdward Arnol*
52. Soares,Ana Rosa (2018) *Trait determinants of impulsive behavior: a comprehensive analysis of 188 rats 1598-018-35537-7*
53. Sonal, Khaira (2016) “Decoding a 'Reflective Personality” *Linked in 2020 Retrieved from <https://www.linkedin.com/pulse/decoding-reflective-personality-sonal-khaira>*
54. Thomas,Lauren (2020) “An Introduction to simple Random Sampling” *Scribbr. Published on August 28, 2020 by Lauren Thomas. Revised on October 2, 2020.Retrieved from <https://www.scribbr.com/methodology/simple-random-sampling/#:~:text=Simple%20random%20sampling%20is%20a,possible%20of%20this%20random%20subset>*
55. Veyssel, Altunel G. (2015) *The Impact of Extroversion and Introversion on Language Learning In An Input-Based Efl Setting*
56. Wallen,Daniel G. (2017) “ 10 Quality Traits All Introverts Have, Even If They Don't Know It” *Lifehack 2021 <https://www.lifehack.org/articles/communication/10-quality-traits-all-introverts-have-even-they-dont-know-2.html>*



57. Wilz, B. (2012). *Relationship between personality type and Grade Point Average of technical college students. Unpublished MA thesis, University of Wisconsin-Sto*
58. Yahaya, Azizi (2010) Faculty of Education, University Technology Malaysia 81310 UTM Skudai Johor, *The Relationship of Personality traits and Reading Performance international Proceedings of Economics Development and Research, Vol. 53, p. 36-40, 2010*





# COVID 19 PANDEMIC: EFFECT ON ACADEMIC PERFORMANCE OF 4P'S GRADE 7 STUDENTS

**Clarissa Q. Villamater**

*Faculty, Paaralang Sekundarya ng Lucban Integrated School*

## ABSTRACT

*This study was conducted to determine the Effect of Covid19 pandemic to 4P's Grade 7 students in Paaralang Sekundarya ng Lucban Integrated School towards in Araling Panlipunan subject. Specifically, it aimed to answer the following questions; (1) What is the demographic profile of the students in terms of; Age, Gender, Proximity, Grades in First and Second Grading, Family Size, Family Income, Financial Aid and Availability in Resources (2) What is the mean level of 4P's Grade 7 students in Paaralang Sekundarya ng Lucban Integrated School towards their performance in Araling Panlipunan subject? (3) Is there a significant effect on 4P's Grade 7 students profile on their Academic Performance in Araling Panlipunan subject during the time of Covid19 Pandemic.*

*The descriptive method of research was employed through quantitative analysis. The questionnaire was administered to sixty (60) 4P's Grade 7 students of Junior High School in Paaralang Sekundarya ng Lucban Integrated School for School Year 2020-2021. Using the Frequency and Percentage formula, Mean and Standard Deviation and Multiple Regression analysis. The results were then analyzed and evaluated. The majority age of the students belonged to group of 11 to 13 years old (78%), there are more Female (55%) student-respondents and the rest are Male (45%). Most of the 4P's Grade 7 students are from Lucban (39%). Students belong to family size that have 4-5 members (50%). Most of the student's family income have 300-400 pesos income per day (48). The 4P's Grade 7 students receive 600 pesos per month (45%). Majority of the students use cell phone (76%) for them to utilize in their study and others don't have any laptop or desktop (0%). Most of the students used mobile data (55%) and high number of 4P's Grade 7 students are not using any internet connectivity (28%). The mean grade during the first grading period was 82.88 and 82.17 during the second grading period with overall mean of Students' Perceptions on their Performance in Araling Panlipunan during the COVID-19 Pandemic is 3.26 indicates that the students believed that the COVID19 Pandemic with the verbal interpretation of affect moderately. The gender of the respondents influences the extent to which they learn the lessons in Araling Panlipunan, as indicated by the beta coefficient of 0.237. The t-value of 2.944 is "significant" at 0.005 probability level; Family income of the respondents influence their academic performance in Araling Panlipunan as indicated by the beta coefficient of 0.176. The t-value of -2.786 is "significant" at 0.007 probability level; the financial aid respondents influence their academic performance in Araling Panlipunan as indicated by the beta coefficient of 0.282. The t-value of 3.719 is "significant" at 0.000 probability level; the Availability of resources respondents influence their academic performance in Araling Panlipunan as indicated by the beta coefficient of 0.162. The t-value of 2.770 is "significant" at 0.050 probability level. The adjusted R-square indicates that 55.0% unit in the students' Academic performance in Araling Panlipunan is explained by gender, family income, financial aid received, and the availability of resources. The F-value of 11.292 is "significant" at 0.000 absolute probability. It was found out statistically the Covid19 pandemic has significant effect on 4P's Grade 7 students profile on their Academic Performance in Araling Panlipunan subject in terms of Gender, Family Income, Family Aid and Availability of Resources. Based on the data, the conclusion was derived that there was a "significant" effect in the Academic Performance of 4P's Grade 7 Students in their Academic Performance in amidst of Covid19 Pandemic. Based on the findings made, the following were hereby recommended: 1.) Principal may be encouraged to design Learning Action Cell (LAC) sessions to have an intervention program addressing to 4P's Grade 7 students' needs to overcome the problem that they encounter due to Covid19 Pandemic 2.) Teachers of student-respondents may communicate with DSWD to find way on how to help the 4P's Grade 7 students' and enable to have continuous personality improvement and individual growth of the students 3.) School Head and Teachers may apply Adopt-to-School Program wherein there is a specific school program for the student-respondents. 4.) In amidst of Covid19 pandemic the teachers and parents of 4P's Grade 7 students should give more encouragement and support the student-respondents for them to be motivated to participate in the School Intervention Program for 4P's beneficiaries. 5.) Local Government and DSWD may give some learning materials that may help the student-respondents in their learning process in amidst of Covid19 pandemic and they should monitor the academic performance of 4P's Grade 7 students'. 6.) Future Researchers are encouraged to do further studies giving emphasis to the variables in the present studies.*



## INTRODUCTION

The Philippine economy struggles when the total lockdown was imposed due to the Covid19 pandemic. Poverty rose and many individuals become jobless, business establishments went bankrupt, and aside from that the children that are belong to poor family's also expose in difficulties that cause by the Covid19 pandemic. Like for example sustaining the essentials that they need for their everyday life and aside from that education that was also affected by the pandemic because they are unable to cope with the new learning modes of education.

Among the marginalized sectors, the members of 4Ps program of the government are greatly affected, because they belong to the poorest of poor their livelihood are greatly affected by the economy lockdown, even though 4P's beneficiaries are receiving financial aid from the government managing their finances is a great challenge especially when they also need to support the education of their children. The continuation of learning demand great changes for everyone, technologies were given a spotlight. Some can immediately accept the changes but the marginalized families find it difficult.

According to Alphonso (2020), distance learning during this pandemic is widening inequities that may end up setting back some children from marginalized communities even further. The home situations of students vary and many may not receive help from families with their schoolwork such parents who are considered essential workers or who are struggling after losing their jobs.

Education is very important. But supporting the daily expenses and supporting the education of the learners in amidst of Covid19 pandemic is a great challenge for the marginalized families. Furthermore, the learners are greatly affected by the sudden changes happen in our world.

This study aimed to determine the demographic profile of the Grade 7 4P's students in Paaralang Sekundarya ng Lucban Integrated School and its effect on their Academic Performance towards in Araling Panlipunan subject.

## RESEARCH METHODOLOGY

In this study, the descriptive method of research was used to answer the problem and to obtain the objectives put forward in this paper.

According to Clemente and Jalston (2016) Descriptive method is widely used method in conducting researches since its main purpose is to have a descriptive picture and scenario on what is really happening in the environment being studied. It is one of the most appropriate methods especially if the study exposes the behavior and perceptions of the respondents towards a common theme.

The descriptive method was used in the study in order to determine the Effect of Covid19 pandemic to 4P's Grade 7 students in Paaralang Sekundarya ng Lucban Integrated School towards in Araling Panlipunan subject.

The primary subjects of this study were the Grade 7 students in Paaralang Sekundarya ng Lucban Integrated School composed of Ten (10) sections. The total population of grade 7 students are 600 students and the total number of 4P's Grade 7 students are composed of 80 students. The respondents of the study were selected sixty (60) 4P's Grade 7 Students in Paaralang Sekundarya ng Lucban. They were randomly selected, the Grade 7 students are composed of ten (10) sections: Courteous (4), Courage (7), Charity (9), Faith (8), Hope (5), Humility (5), Honesty (7), Love (6), Peace (6) and Wisdom (3).

Seventy five Percent (75%) (60 students) out of one hundred percent (100%) (80 4P's students) from Paaralang Sekundarya ng Lucban Integrated School are the are the estimated total number of 4P's students who will serves as the respondent of the study. They are select as the sample group of the study using purposive sampling technique.

This study started from the formulation of its title. After the title was made, the researcher presented it for approval in title defense. When the title has been successfully defended and approved by the panelist, the researcher browsed the internet, different kinds of books, thesis, journal and magazines, in order to collect the precise variables to formulate a conceptual paradigm and also for gathering any related literature and studies for the corresponding variables.

To conduct the study, the researcher prepared a self-made questionnaire. The draft of the prepared self-made questionnaire was presented to the adviser for the improvement and was validated by validators then the letter of validation has been signed.

Before the distribution of the questionnaires, to the selected respondents, the researcher asked first the permission from the Division of Quezon as noted by the researcher herself and was concurred by her adviser for the conduct of the study.



After the approval of the letter by the Superintendent of Division of Quezon, the researcher administered the questionnaire with the help of duly constitute authorities. The questionnaires determined the Effect of Covid19 pandemic to 4P's Grade 7 students in Paaralang Sekundarya ng Lucban Integrated School towards in Araling Panlipunan subject.

The data collected was completed and treated using statistical treatment.

### Statistical Treatment of Data

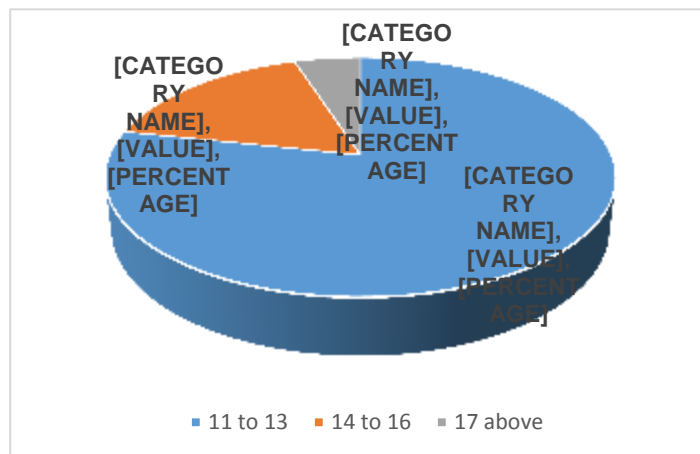
Statistical treatment of data of the present study is shown on the table below.

Statement of the Problem	Statistical Tool
1. To derive frequencies of the demographic data of the respondents.	Frequency and Percentage- formula – were used
2. To determine the Mean Level of 4P's Grade 7 students towards their Performance in Araling Panlipunan	Mean and Standard Deviation were used.
3. To know the significant effect on 4P's Grade 7 students profile on their Academic Performance in Araling Panlipunan subject during the time of Covid19 Pandemic.	Multiple Regression analysis was also used.

## RESULTS AND DISCUSSIONS

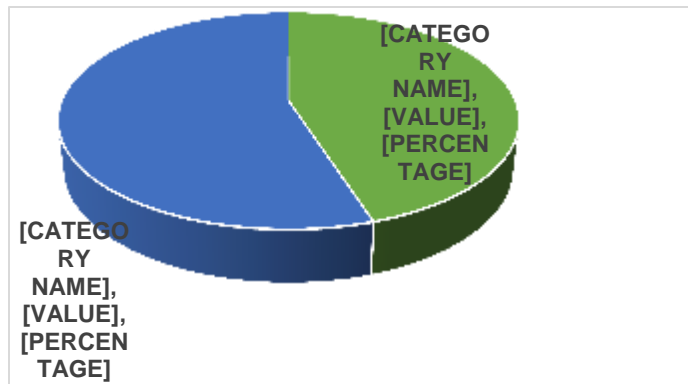
The profile of the students determines the demographic profile of the students. The gathered data on the demographic profile of the students served as validation and measurement on what are the current situation of the 4P's Grade 7 students in amidst of pandemic. And how Covid-19 affects their Performance in Araling Panlipunan.

The profile of the students was described as to age, gender, proximity, family size, family income, financial aid received per month, availability of resources, and their grades in first and second grading period.



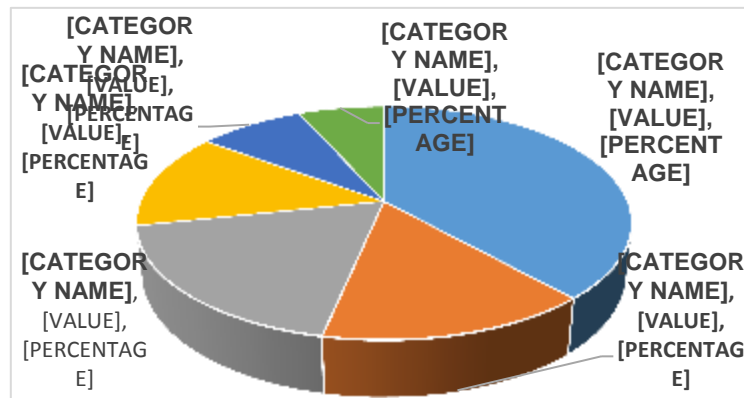
**Figure 2. Students' Demographic as to Age**

Figure 2 shows the age of the student-respondents. Majority of the students belong to group of 11 to 13 years old (78%), while the rest are from 14 to 16 years old (17%) or 17 years old and above (5%). This means that majority of the students are young adolescents. This is the normal age range of Grade 7 students.



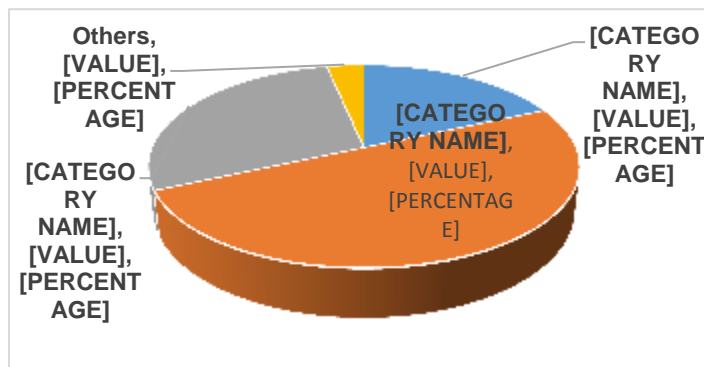
**Figure 3. Students' Demographic as to Gender**

Figure 3 shows the Gender of the student-respondents. Most of the students are Female (55%) and the rest are Male (45%). This means that majority of the 4P's Grade 7 students are Female.



**Figure 4. Students' Demographic as to Proximity from Paaralang Sekundarya ng Lucban Integrated School**

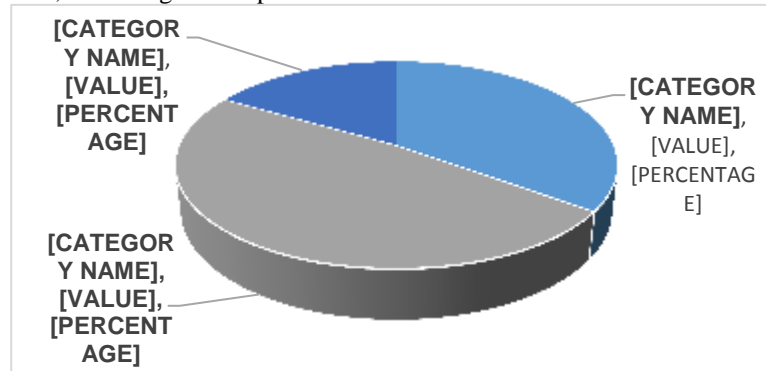
Figure 4 shows the Proximity of the house location of the students-respondents from Paaralang Sekundarya ng Lucban Integrated School that is situated at Barangay Aliliw, 13 kilometer from the town proper. Majority of the students are from Lucban (39%), and there are some who live in Tayabas (18%), some are in Lucena (15%), and there are also from Luisiana (13%) while the rest are from Majayjay (8%) and others (7%). This means that there are more 4P's Grade 7 students who live in Lucban.



**Figure 5. Students' Demographic as to Family Size**

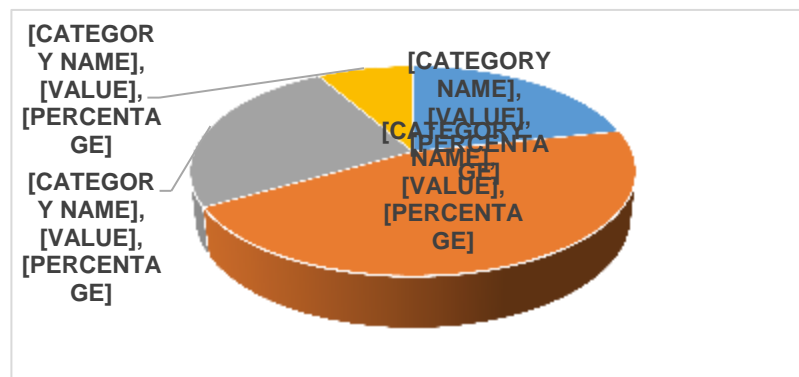


Figure 5 shows the Family Size of the student-respondents. Majority of the students have a 4-5 members (50%), some of the students have 6-10 members (28%), while the rest have 2-3 members (18%) and others (4%). This means that most of the beneficiary of 4P's Grade 7 students belong to large family. Large family is a category which includes 3 or more children, excluding the couple.



**Figure 6. Students' Demographic as to Family Income**

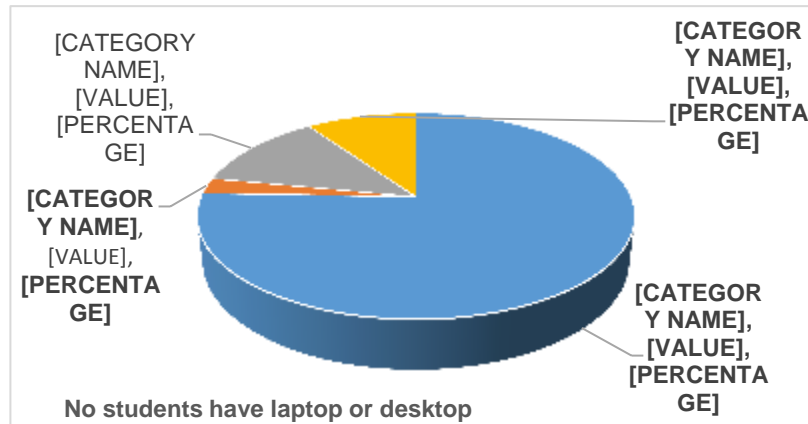
Figure 6 shows the Family Income of the student-respondents. Most of the students have 300-400 pesos Family income per day (48%), and there are 1-200 pesos Family income per day (35%), while the rest have 500-600 pesos income per day (17%). This means that majority of the 4P's Grade 7 Students Family income per day belong to the minimum wage. According to Region IV-A; Wage Order No. IVA-18, under the R.A.6727 "The Wage Rationalization Act".



**Figure 7. Students' Demographic as to Financial Aid Received**

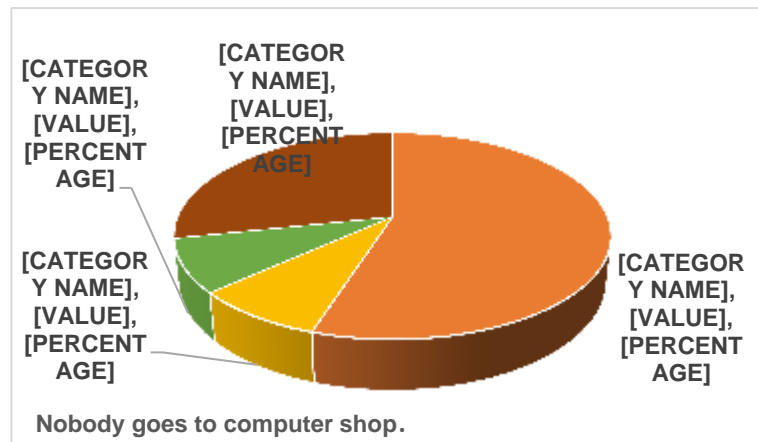
Figure 7 shows the Financial Aid of the student-respondents. Majority of the 4P's Grade 7 students receive 600 pesos per month (45%) that may help their family in their everyday necessities, some are receiving 900 pesos per month (25%), while the rest received 300 pesos per month (22%) and others (8%). 4P's Financial Aid was always depend on the number of dependent children in one family. Pursuant to Section 23 of Republic Act (RA) No.11310, or otherwise known as "An Act Institutionalizing the Pantawid Pamilyang Pilipino Program (4P's).





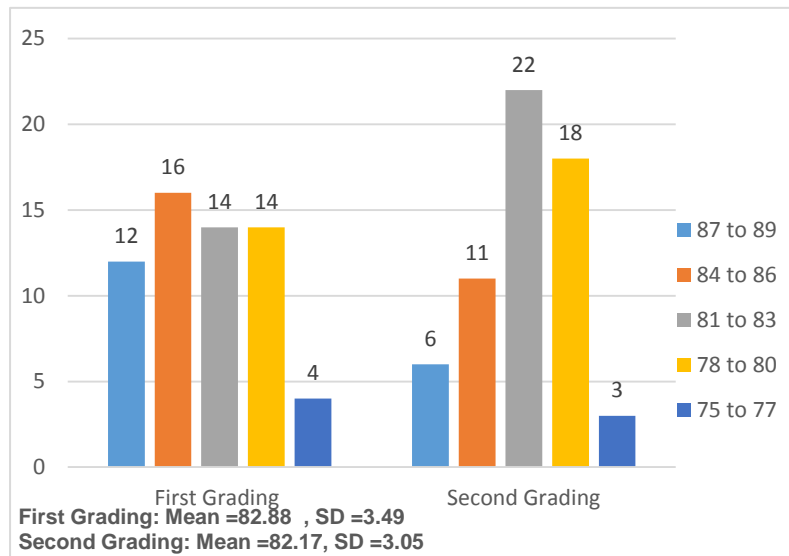
**Figure 8. Students’ Demographic as to Available Technology Gadgets**

Figure 8 shows the Available Technology Gadgets of the student-respondents. Majority of the students use cell phone (76%) for them to utilize in their study, some of them have television (12%) in their houses, there are also student-respondents who have radio (10%), while the rest have tablet (2%) and others don’t have any laptop or desktop (0%) that may help them in studying.



**Figure 9. Students’ Demographic as to Available Internet Connectivity**

Figure 9 shows the Available Internet Connectivity of the student-respondents. Most of the students used mobile data (55%), there are also use Pocket wifi (9%), low number of student-respondents have internet/wifi (8%) and high number of 4P’s Grade 7 students are not using any internet connectivity (28%).



**Figure 10. Students' Grades in the First and Second Grading Period**

The students' performance in Araling Panlipunan subject during the first and second grading period is presented in Figure 10.

During the first grading period, the range grade with highest frequency was 78 to 80 (26.67%) while in the second grading period is 81 to 83 (36.67%). There were four students who obtained a grade from 87 to 89 (6.67%) during the first grading period and three during the second grading period (5.0%).

The mean grade during the first grading period was 82.88 and 82.17 during the second grading period. The students show almost the same distribution of grades for the two grading periods, as indicated by the standard deviation.

This means that the students' level of performance in Araling Panlipunan are almost in the same level. However, it means that 4P's Grade 7 students are *satisfactory* in their performance during the two grading periods as categorized by Deped Order No.8 series of 2015 titled Policy Guidelines on Classroom Assessment for K to 12 BEC. Furthermore, different factors may affect this kind of findings such as availability of gadgets/Technology and too much use of social media.

According to the study of Fordjour, et. Al, (2020) the effect of the covid-19 pandemic on learning among Ghanaian students. It came to light that the pandemic really has had a negative impact on their learning as many of them are not used to effectively learning by themselves. The e-learning platforms rolled out also possessed challenge to majority of the students because of the limited access to internet and lack of the technical knowhow of these technological devices by most Ghanaian students. The study, therefore recommends that students and teachers alike be introduced to e-learning platforms and how to effectively use it for instructional practice in the wake of such challenges in our educational system. The outcome of the study will go a long way in helping policy makers to come out with a lasting policy to address challenges faced by students when they are home for their normal semester break or during a pandemic of this nature.

Liu, Zhou, Yang, Kong, Niu, & Fan, (2020) stated that, the main objectives of having an isolation strategy is to lessen the increase of Covid19 cases. Social distancing in local community was strictly practice, however social distancing will result changes to young individual's social interaction and behaviors. Like for example they are using their mobile phones to have an information that may result to have an internet over used. Poor sleep quality and unwell health condition will experience by the young individual.

An individual need compassion and at the same time the learnings and knowledge that they can acquire in every person around them. But when the Covid19 pandemic happens social distancing and community quarantine was implemented, interacting with their relatives, friends and peers become very difficult. Using social media every day and night become a hobbit to kill the boredom and loneliness. We all know, that too much using of everything is bad and it might be cause to have a greater problem.



### Effect of Students' Demographic Profile on their Academic Performance in Araling Panlipunan Subject

**Table 9. Regression Analysis on the Effect of Students' Demographic Profile on their Academic Performance in Araling Panlipunan Subject**

Profile	Beta	t-value	p-value	Analysis
Age	-0.027	-0.238	0.813	Not significant
Gender	0.237	2.944	0.005	<b>Significant</b>
Proximity	-0.045	-0.805	0.424	Not significant
Family size	0.135	1.563	0.124	Not significant
Family income	0.176	-2.786	0.007	<b>Significant</b>
Financial aid	0.282	3.719	0.000	<b>Significant</b>
Availability of resources	0.162	2.770	0.050	<b>Significant</b>

Adjusted R-Square = 0.550

F-Value = 11.292

Sig. = 0.000

The gender of the respondents influences the extent to which they learn the lessons in Araling Panlipunan, as indicated by the beta coefficient of 0.237. The t-value of 2.944 is significant at 0.005 probability level. In this study, there are more female students than male students. According to Chesley, (2020), when community quarantine has greatly secured the safety of every family. The need for care both outside and inside their homes was also implemented because of the outbreak of Covid19 pandemic. Every family that have dependents are one of the groups that was most affected by the stress given by being confinement for so how many months. Within families, women are the greatly affected because of the burden in thinking of how they will deal with the changes happen in our society. When the Covid19 occurred, the support needed by the students become less. Women who are experiencing burden, physically and mentally workload do not accomplish their everyday activities in a normal way. Aside from that the other people around them may also be affected like for example their children may feel the burden and it may also affect the performance of their children in their school.

The Family income of the respondents influence their academic performance in Araling Panlipunan as indicated by the beta coefficient of 0.176. The t-value of -2.786 is significant at 0.007 probability level. In this study, the Family income was a great help to overcome the problems that was encounter due to the Covid19 Pandemic.

Unity, Osagioba and Edith (2013) emphasized that a student is affected negatively if he/she comes from an economically disadvantaged family. They stressed further that such children are faced with overwhelming challenges that leads to poor school performance. Because of the stressed that they experience it may lead them to feel unmotivated to do their school activities properly. Aside from that they may just stop studying .Poverty causes a child to forget the importance of education and just focus in working.

The Financial aid respondents influence their academic performance in Araling Panlipunan as indicated by the beta coefficient of 0.282. The t-value of 3.719 is significant at 0.000 probability level. In this study, the Financial Aid given by the government was important and may be a supplement support to sustain the necessities like food, medicine and education. Attanasio et al. (2010) stated not only the young individual but also the children will benefit the 4Ps programs, it was looking forward to lead a greater impact in terms of point percentages on school participation of children in the older age range. These studies reveal that 4Ps programs have prominent impact on older than younger children. A study on the Colombian case manifest that the 4Ps improved the school participation of 14- to 17-year-old children quite substantially, by 5 to 7 percentage points.

Financial Aid can lead the beneficiaries to be more motivated in supporting the needs of their children and to acquire the daily needs that they need.

The Availability of resources respondents influence their academic performance in Araling Panlipunan as indicated by the beta coefficient of 0.162. The t-value of 2.770 is significant at 0.050 probability level. In this study, the Availability of resources assist the students to have sufficient knowledge in answering their modules in amidst of the new normal.



Wu, (2020) stated that the sudden change of education to online learning became a way to every school to have an effective plan for the continuation of education. Many educational institutions primarily focused on the innovation of educational content to the digital world and not specifically on online teaching and delivery methods. Nonetheless, it was a reminder of the lack of resources in academic institutions and the social marginalization of students, where insufficient access and availability of the internet and the lack of latest technology affected organizational responsiveness and students' capacity to participate in digital learning (Zhong, 2020). Lack of proper interaction and communication with teachers/educators is another major concern associated with online learning. Additionally, concerns regarding any content of the new platform of learning are usually discussed with modules, which can be more effective when there is a messenger, video presentations or video call that will instruct the students on how they will make the particular activity. Virtual classes cannot be of interest to students who are tactile learners. Conventional classroom socialization is another major missing in online learning. Furthermore, when student encounter a problem in their learning process, they can ask their friends, classmates or peers and communication are still needed, technology such as cell phones, tablet and laptops are main gadgets that can ease the problems of students. Aside from that, television and radio are capable to help students but still when it comes to communication and interaction it is not suited to assist the learners.

The adjusted R-square indicates that 55.0% unit in the students' Academic performance in Araling Panlipunan is explained by gender, family income, financial aid received, and the availability of resources. The F-value of 11.292 is significant at 0.000 absolute probability. This means, there are factors that affect 4P's Grade 7 students due to Covid19 pandemic they had experience. Sudden changes they encounter in their learning process resulted in their development. As stated by McCarthy, (2020) Educational institutions are one of the main centers of social activities and interactions of a learner. When educational activities are suspended, many children and young people miss active social interaction-based activities that can help them for their learning, growth and development. Students should still continue to learn, particularly the underprivileged children and young adults, both of whom experience the impact of schools' suspension, so this is a huge issue that should find a solution. While short term closure of educational institutions as a consequence of emergencies the world has currently facing, the pace of present-day educational instability is sadly unparalleled and, if sustained, may inflict psychological distress and misery at various levels.

Educational institutions are the main place where many children and young people enjoy and at the same time develop their skills, ability and cognitive level. But when the face to face was strictly prohibited children and young adolescents are the most affected because they are prohibited to freely express themselves, so this may affect them psychologically. Their social interaction was minimized but still the educational institutions manage to continue the learning of young adolescents, and with the help of learning resources such as internet connection, android cell phones, tablet and laptops. When it comes to marginalized people the new platform of education is a great challenge because they are unable to sustain the needs for the continuation of education.

## CONCLUSIONS

Based on the foregoing findings of the study, it is concluded that there was a significant effect on the 4P's Grade 7 Students profile on their Academic Performance in amidst of Covid19 Pandemic. It shows that the null hypothesis stating "There is no significant difference of Covid19 Pandemic to 4P's Grade 7 students in Paaralang Sekundarya ng Lucban Integrated School towards their Performance in Araling Panlipunan subject", was rejected. Therefore, it shows that there was a significant effect on effect on the 4P's Grade 7 Students profile on their Academic Performance in amidst of Covid19 Pandemic.

## RECOMMENDATIONS

Based on the findings made, the following were hereby recommended:

1. Principal may be encouraged to design Learning Action Cell (LAC) sessions to have an intervention program addressing to 4P's Grade 7 students' needs to overcome the problem that they encounter due to Covid19 Pandemic.
2. Teachers of student-respondents may communicate with DSWD to find way on how to help the 4P's Grade 7 students' and enable to have continuous academic improvement and individual growth of the students
3. School Head and Teachers may apply the Adopt-A-School Program wherein there is a specific school program for the student-respondents.



4. In amidst of Covid19 pandemic the teachers and parents of 4P's Grade 7 students may give more encouragement and support the student-respondents for them to be motivated to participate in the School Intervention Program for 4P's beneficiaries.
5. Local Government Units and DSWD may provide some learning materials that may help the student-respondents in their learning process in amidst of Covid19 pandemic and monitor the academic performance of 4P's Grade 7 students.
6. Future Researchers are encouraged to do further studies giving emphasis to the variables in the present studies.

## REFERENCES

1. Andersen, S C, and H S Nielsen (2019), "Learning from Performance Information", *Journal of Public Administration Research and Theory*.
2. Antonio G. Dacanay and Florisa B. Simson (2016) ,*Development and Validation of an Achievement Test in Araling Asyano with Questions, Addressing the K to 12 Araling Panlipunan Skills, The Normal Lights Volume 10, No. 2* (2016)
3. Asikhia, O.A. (2010), "Students and teachers' perception of the causes of poor academic performance in Ogun State secondary schools, Nigeria: Implications for Counselling for National Development", *European Journal of Social Sciences*. 13(2):229-249.
4. Attanasio, O., E. Fitzsimons, A. Gomez, M. I. Gutierrez, C. Meghir, and A. Mesnard. (2010). *Children's schooling and work in the presence of a Conditional Cash Transfer Program in Rural Colombia*. Available online at <http://www.homepages.ucl.ac.uk/~uctpjrt/Files/edccfamilias.pdf>.
5. Berliner, D. C. (2010). Are teachers responsible for low achievement by poor students? *Education Digest*, 75(7), 4–8.
6. Blaskó, Z., Papadimitriou, E., Manca, A.R. (2020). How will the COVID-19 crisis affect existing gender divides in Europe? *Luxembourg: Publications Office of the European Union*
7. Borup, J., West, R. E., Graham, C. R., & Davies, R. S. (2014). *The adolescent community of engagement framework: A lens for research on K-12 online learning*. *Journal of Technology and Teacher Education*, 22(1), 107–129.
8. Carlsson, M, G B Dahl, B Öckert and D Rooth (2015), "The Effect of Schooling on Cognitive Skills", *Review of Economics and Statistics* 97(3): 533–547
9. Casinto, C. & Cuizon, R. (2010). *Handbook of Principles of Teaching 2*, Rex Bookstore Inc., and Date Retrieved November 22, 2020
10. Catubig, M., Villano, R., & Dollery, B. (2015). *Payment Schemes in Conditional Cash Transfer Programs: The Case of 4Ps in the Davao Region, Philippines*. *Administrative Sciences*, 5(4), 240-259. <https://doi.org/10.3390/admsci5040240>
11. Chillón, P., Hales, D., Vaughn, A., Gizlice, Z., Ni, A., Ward, D.S., 2014. A cross sectional study of demographic, environmental and parental barriers to active school travel among children in the United States. *Int. J. Behav. Nutr. Phys. Act.* 11, 1.
12. Crosnoe, R., & Cooper, C. E. (2010). *Economically disadvantaged children's transitions into elementary school: Linking family processes, school contexts, and educational policy*. *American Education Research Journal*, 47(2), 258–291, doi: 10.3102/000283120935156Edgar Jon Sintema., (2020). *Effect of Covid-19 on the Performance of Grade 12 students: Implications for STEM Education*. *EURASIA Journal of Mathematics, Science and Technology Education*, 2020, 16 (7),em 1851 <https://doi.org/10.29333/ejmste/7893>
13. Cohen, J., & Geier (2010). *School climate research summary, January 2010*. [Retrieved December, 2020 from]. [www.schoolclimate.org/climate/research.php](http://www.schoolclimate.org/climate/research.php).
14. Cohen, J., & Kupferschmidt, K. (2020). Countries test tactics in 'war' against COVID-19. *Science*, 367(6484), 1287-1288. <https://doi.org/10.1126/science.367.6484.1287>
15. DanielMunevar, (2020). *The Philippine, Covid19 and debt: Left alone to deal with the pandemic*. *European network on debt and development* [https://www.euroadad.org/thephilippinescovid19anddebtleftalonetodealwiththe\\_pandemic](https://www.euroadad.org/thephilippinescovid19anddebtleftalonetodealwiththe_pandemic)
16. Dolan, J. E. (2016). *Splicing the divide: A review of research on the evolving digital divide among K–12 students*. *Journal of Research on Technology in Education*, 48(1), 16-37. <https://doi.org/10.1080/15391523.2015.1103147>
17. DSWD. (2018). *Philippines' Conditional Cash Transfer (CCT) Program Pantawid Pamilyang Pilipino Program*. Retrieved from <https://pantawid.dswd.gov.ph/>.
18. E.Ganga; K.Chinyoka and R.Mugweni R. Mugabe (2018). *Effects of Parental Schooling and Family Size on the Academic Performance of the Adolescent Learner in Zimbabwe*. *Journal of Popular Education in Africa*. 2(9), 36- 51 <http://www.jopea.org/index.php/current-issue> *Effects of Parental Schooling and Family Size on the Academic Performance of the Adolescent Learner in Zimbabwe Journal of Popular Education in Africa September 2018, Volume 2, Number 9 ISSN 2523-2800*
19. Faulkner, G., Stone, M., Buliung, R., Wong, B., Mitra, R., 2013. *School travel and children's physical activity: a cross-sectional study examining the influence of distance*. *BMC Public Health*.
20. Fernandez, L., & Velarde, R. (2011). *Overview of the Philippines' conditional cash transfer program: The Pantawid Pamilyang Pilipino Program (Pantawid Pamilya)*. *Philippine Social Protection Note, No. 2 (Report No. 62879)*. Manila: World Bank Group and Australian Government Aid Program.





21. Fredriksson, P, L Hensvik, and O Nordström Skans (2018), "Mismatch of Talent: Evidence on Match Quality, Entry Wages, and Job Mobility", *American Economic Review* 108(11): 3303-38.
22. Garfin, D. R., Silver, R. C., & Holman, E. A. (2020). The novel coronavirus (COVID-2019) outbreak: Amplification of public health consequences by media exposure. *Health Psychology*, 39,355–357. <http://dx.doi.org/10.1037/hea0000875>
23. Glewwe P. and A.L. Kassouf. 2010. The Impact of the Bolsa Escola/Familia Conditional Cash Transfer Program on enrolment, dropout rates and grade promotion in Brazil. Available online at <http://faculty.apec.umn.edu/pglewwe/documents/BrBolsa6.pdf>. Retrieved on December, 2020
24. Horesh, D., & Brown, A. D. (2020). Traumatic stress in the age of COVID-19: A call to close critical gaps & adapt to new realities. *Psychological Trauma: Theory, Research, Practice and Policy*, 12,331335.<http://dx.doi.org/10.1037>
25. Kantamneni, N. (2020). The impact of the COVID-19 pandemic on marginalized populations in the United States: A research agenda. *Journal of Vocational Behaviour*, 119, Article 103439. <https://doi.org/10.1016/j.jvb.2020.103439>
26. Lavy, V. (2015), "Do Differences in Schools' Instruction Time Explain International Achievement Gaps? Evidence from Developing and Developing Countries", *Economic Journal* 125.
27. Lee, J., 2020. Mental health effects of school closures during COVID-19. *Lancet. Child Adolescent Health*, S2352-4642(20)30109-7. [https://doi.org/10.1016/S2352-4642\(20\)30109-7](https://doi.org/10.1016/S2352-4642(20)30109-7). PubMed.
28. Liu, F., Black, E., Algina, J., Cavanaugh, C., & Dawson, K. (2010). The validation of one parental involvement measurement in virtual schooling. *Journal of Interactive Online Learning*, 9(2), 105–132.
29. Liu, Q. Q., Zhou, Z. K., Yang, X. J., Kong, F. C., Niu, G. F., & Fan, C. Y. (2017). Mobile phone addiction and sleep quality among Chinese adolescents: A moderated mediation model. *Computers in Human Behavior*, 72, 108-114.
30. Maslow, A. H. (1943). A Theory of Human Motivation. *Psychological Review*, 50, 370-96. McLeod, S. A. (2007). Maslow's Hierarchy of Needs. Retrieved from <http://www.simplypsychology.org/maslow.html><http://thesocialworkexam.com/maslows-theory-of-basic-needs-learning>
31. McCarthy, K. (2020, March 7). The global impact of coronavirus on education. Retrieved from ABC News: <https://abcnews.go.com/International/global-impact-coronavirus-education/story>
32. McQuillan, H., Neill, B.O., 2010. Gender differences in children's internet use: key findings from Europe. *J. Child. Media* 3 (4), 366–378. <https://doi.org/10.1080/17482790903233408>.
33. Murphy, R and G Wyness (2020), "Minority Report: the impact of predicted grades on university admissions of disadvantaged groups", CEPEO Working Paper Series No 20-07 Centre for Education Policy and Equalising Opportunities, UCL Institute of Education.
34. Mwamwenda, T. S (2010). *Educational Psychology: An African Perspective*. Pietermaritzburg; Butterworth Publishers.
35. Oreopoulos, P, T von Wachter, and A Heisz (2012), "The Short- and Long-Term Career Effects of Graduating in a Recession", *American Economic Journal: Applied Economics* 4(1): 1-29.
36. Owusu-Fordjour, C., Koomson, C. K., Hanson, D. (2020). The Impact of Covid-19 on Learning - The Perspective of the Ghanaian Student. *European Journal of Education Studies*, 2020 Volume 7 Issue 3 [https://doi: 10.5281/zenodo.3753586](https://doi.org/10.5281/zenodo.3753586) [www.oaupub.org/edu](http://www.oaupub.org/edu)
37. Piopiunik, M, G Schwerdt, L Simon and L Woessman (2020), "Skills, signals, and employability: An experimental investigation", *European Economic Review* 123: 103374.
38. Porche, M. V., Fortuna, L. R., Lin, J., & Alegria, M. (2011). Childhood trauma and psychiatric disorders as correlates of school dropout in a national sample of young adults. *Child Development*, 82,982–998.<http://dx.doi.org/10.1111/j.1467-8624.2010.01534.x>
39. Qiu, J., Shen, B., Zhao, M., Wang, Z., Xie, B., & Xu, Y. (2020). A nationwide survey of psychological distress among Chinese people in the COVID-19 epidemic: Implications and policy recommendations. *General Psychiatry*, 33, e100213 <http://dx.doi.org/10.1136/gpsych-2020-100213>
40. Richter, A. (2020). Locked-down digital work. *International Journal of Information Management*, 102157. <https://doi.org/10.1016/j.ijinfomgt.2020.102157>.
41. Simon B, & Hans H, S, (2020) Schools, skills, and learning: The impact of COVID-19 on education <https://voxeu.org/article/impact-covid-19-education>. <https://www.universityworldnews.com/post.php?story=20200324065639773> The Loudoun County Health Department is reporting the first death of a hospitalized patient
42. Timothy Kisambira (2016), Students walking to school. Research shows that long distances to school affect students' concentration by Times Reporter Published: July 06, 2016 <https://www.newtimes.co.rw/section/read/201440>
43. Theffidy, S. (2020). Pendidikan Era Revolusi Industri 4.0 di Tengah Covid-19. Retrieved on July 18, 2020 from <https://ombudsman.go.id/artikel/r/artikel--pendidikan-era-revolusi-industri-40-di-tengah-covid-19>
44. Tubeza, P. & Leonen, J. (2018) SWS: 10 million Filipino families rate themselves poor. Retrieved from <https://newsinfo.inquirer.net/960930/sws-10-million-filipino-families-rate-themselves-poor>
45. Unity, O., Osagioba, O.E., Edith, O. (2013), "The influence of poverty on students' behavior and academic achievement", *International Journal of Educational Research* 2(1): 151-160.
46. Vidyut Rajhans, Usman Memon, Vidula Patil, Aditya Goyal (2020) Impact of COVID-19 on academic activities and way forward in Indian Optometry, *Journal of Optometry* (2020), doi: <https://doi.org/10.1016/j.optom.2020.06.002>



47. *Wheeler Report*. (2020, July, 8). *Education and COVID-19 – Part II – Technology – The Wheeler Report*. <http://www.thewheelerreport.com/blog/2020/06/17/education-and-covid-19-partii-technology>
48. Wu, Z. (2020). *How a top Chinese university is responding to coronavirus*. Retrieved from *World Economic Forum*: <https://www.weforum.org/agenda/2020/03/coronavirus-china-the-challenges-ofonline-learning-for-universities/>
49. Zimmerman, T., Schmidt, .L, Becker, J., Peterson, J., Nyland, R., & Surdick, R. (2014). *Narrowing the Gap between Students and Instructors: A Study of Expectations*. *Transformative Dialogues: Teaching and Learning Journal*, 7(1), 1-18



# CONCEPT AS A SYNTHESIS OF THE ELEMENTS OF LANGUAGE AND CULTURE

Popov Dmitry Vladimirovich

Doctor of Philosophy (PhD) in Philology, Associate Professor, Department of Russian Language and Literature, Andijan State University, Uzbekistan

Article DOI: <https://doi.org/10.36713/epra7401>  
DOI No: 10.36713/epra7401

## ABSTRACT

*The article deals with the problem of the relationship and interaction of language and culture. Language and culture are inextricably linked, and the concept is the connecting link between them. Currently, the concept turns out to be one of the key concepts of modern linguistics, since it allows each person to enter the culture of his society and, to a certain extent, influence it. Language acts as a mechanism, without the help of which culture would not find its expression.*

**KEYWORDS:** *language of the people, culture, language and culture, concept, cultural linguistics, intercultural communication.*

As we know, one of the topical issues in the field of language research at the present stage of the development of linguistics is the study of the problem of the relationship between language and culture. This issue is one of the most important, since each culture is perceived and considered in tandem with the language of the people – the bearer of the culture. At the same time, language acts as a mechanism, without the help of which culture would not find its expression. That is why it is important to know the relationship between culture and language and how they affect each other.

Language can be viewed as a surface manifestation of a person's existence in culture. Since the 19th century, with the works of J. Grimm, R. Rask, W. von Humboldt, A.A. Potebnya and to this day the problem of the relationship between language and culture is considered as a central issue in linguistics.

The first to seriously study this problem was the largest German philologist, philosopher, linguist, one of the founders of linguistics as a science W. von Humboldt [3]. The main provisions of his concept can be summarized as follows:

1) Language is the embodiment of material and spiritual culture;

2) Any culture has its own national flavor. National specificity is expressed in the language through the prism of the special worldview of each

nation; the language has an internal form characteristic of each community;

3) The internal form of the language allows you to identify and reflect the "national spirit" and its cultural values;

4) Language is a mediating link between a person and the world around him [8].

The idea that the structure of language and reality is similar was reflected in the works of the outstanding Danish linguist, author of glossmatics – the original structuralist theory of language – Louis Elmslev, who noted that the structure of language can be equated with the structure of reality. Or, at least, the structure of language can be perceived as a reflection of reality, albeit a little deformed, without absolute accuracy [5]. E.F. Tarasov notes that culture includes language as the "body" of a sign. It follows from this that language is a cultural subject [11]. The linguistic and communicative ability of a person is objectified in linguistic form, in the meaning of a linguistic sign, which is also a cultural formation. It arises exclusively in human activity. But culture is also included in the language. This conclusion can be reached due to the fact that the culture is completely modeled in the text [8].

However, the points of contact and interaction between language and culture need to be examined carefully. Do not forget that language and culture are different semiotic systems, which means



that they have their own differences, as well as a lot in common, namely:

1) Such forms of consciousness as culture and language are a reflection of a person's vision of the world;

2) Culture and language exist in a dialogue with each other;

3) The subject of culture and language is always an individual or a society, a person or a society;

4) There is one common feature for language and culture – normativity;

5) Historicism is one of the essential properties of culture and language;

6) "dynamics-statics" is the antonymy that is inherent in language and culture.

Language and culture have common ground in the following:

1) In communication processes;

2) In ontogenesis;

3) In phylogeny.

Differentials between language and culture lie in the following factors:

1) Culture values elitism, selectivity, while in the phenomenon of language, preference is given to the mass addressee;

2) Culture is not capable of self-organization, although, like language, it is a sign system [8].

From the above provisions, it follows that the similarity between language and culture is not absolute. These two entities have only a similar structure.

The relationship between language and culture is an extremely complex and multifaceted picture. Today, there are several approaches to solving this issue. The first approach mainly includes the concepts of domestic scientists, among which S.A. Atanovsky, G.A. Brutyan, E.I. Kukushkina, E.S. Markarian. The main postulate of this approach is the idea that the relationship between language and culture implies movement along one vector, in one direction. It follows from this statement that culture is an integral component of reality that a person constantly encounters, and language is a direct reflection of this reality, from which it follows that language is a simple reflection of culture.

Thus, based on the postulates of the first approach, the influence of culture on the language becomes obvious. However, the question of the reverse impact of language on culture remains open so far. It is this question that constitutes the essence of the second approach to the problem of the relationship between language and culture. Such scientists of the 19th century as W. Humboldt and A.A. Potebnya, they considered language to be a spiritual force. They believed that language is such an environment around us, outside of which and

without whose participation we cannot live. W. Humboldt wrote that language is a kind of world that lies between the external and internal world of a person [3]. Thus, being our environment, language does not exist outside of us as an objective given. He is in ourselves, in our consciousness, in our memory. Each movement of thought changes the outline of the language. Language also changes with each new socio-cultural role. Within the framework of this approach, the school of E. Sapir and B. Whorf and various schools of the Neo-Humboldtians worked. They developed the so-called hypothesis of linguistic relativity. The main postulate of this hypothesis is the belief that people see the world differently – each through the prism of his native language [9; 17]. Supporters of this hypothesis believe that the real world exists insofar as it is reflected in language. But if each language reflects reality in a way inherent only to it, then, consequently, languages differ in their "linguistic pictures of the world." The Sapir-Whorf hypothesis has the following basic provisions:

1. The way of thinking of the people speaking it depends on the language.

2. The way of knowing the real world is directly dependent on the languages in which the subjects cognizing this world think [8].

In the studies of some authors, the hypothesis of linguistic relativity has received a modern, topical sound. First of all, in the works of D. Alford, J. Carroll, D. Hymes and other researchers, where the Sapir-Whorf concept was further developed. So, D. Hymes added one more principle, which consists in the idea of the existence of functional relativity of languages. According to this principle, the difference between the languages of the world lies in the nature of their communicative functions [17]. It should be noted, however, that not all scientists share the ideas of the hypothesis of linguistic relativity. There are a number of works that question and sharply criticize the position of this hypothesis. So, B.A. Serebrennikov explains his negative attitude to this hypothesis with the following arguments:

1) Objects and phenomena of the surrounding world are the source of the emergence and existence of concepts. Any language in its genesis is the result of the reflection of the surrounding world by a person, and not by a self-sufficient force, a substance that creates the world;

2) The language is highly adapted to the peculiarities of the physiological organization of a person. However, it should be remembered that these features arose as a result of long-term adaptation of a living organism to the surrounding world;

3) during the period of the primary nomination, an unequal division of the extra-linguistic continuum occurs, which is explained by the unevenness of associations and differences in



linguistic material that have survived from the time of previous eras [10].

D. Dodts, G.V. Kolshansky, R.M. White, R.M. Frumkina, E. Hollenstein. Thus, we can come to the conclusion that the hypothesis of linguistic relativity has an ambiguous attitude towards it on the part of modern linguistic scientists. Nevertheless, all researchers who are seriously dealing with the problem of the relationship between language and culture, language and thinking turn to it. This is due to the fact that it is with the help of this hypothesis that those facts of the language that are difficult to explain in any other way can be understood. An example is the ethnolinguistic works of the school of N.I. Tolstoy [13; 14; 15], the linguo-anthropological works of the school of E. Bartminsky [2] and others.

Further reasoning about the relationship between language and culture refers to the third approach, the main idea of which boils down to the fact that language is a fact of culture. This hypothesis is explained by the following provisions:

1) Language makes up a significant part of the culture that we inherit from our ancestors, predecessors;

2) Language is the very main tool with which we assimilate culture;

3) Language is the most important cultural phenomenon. If we want to understand the essence of culture – science, religion, literature, then we must consider these phenomena as codes that are formed in the same way as language is formed. This is due to the fact that natural language as a classical semiotic system has the best of the existing developed models. Therefore, conceptual comprehension of culture can occur only through the medium of natural language.

As K. Levi-Stross noted, language is both a product of culture and at the same time its important component [7]. In other words, language contains the most important condition for the existence of culture. Moreover, language is a specific way of cultural existence, which is a necessary factor in the formation of cultural codes.

The relationship between language and culture can be seen as a relationship between part and whole. Language can be perceived as a component of culture and as an instrument of culture. However, language is an autonomous structure in relation to culture as a whole. It can be viewed as an independent semiotic system. According to this concept, every native speaker is also a bearer of culture. This means that linguistic signs acquire the ability to perform the function of cultural signs. Thus, linguistic signs are a means of representing the main cultural attitudes. That is why the language has the ability to reflect the cultural and national mentality of its speakers. You can relate culture to language through the concept of space. So, each culture has its own key, key words. For example, for Germans it

means order, accuracy, punctuality, for Americans - practicality, pragmatism, individualism, for Russians these words are soul, longing, collectivism, and for Tajiks - hospitality and cordiality. So how is the system of cultural values reflected in the language? To be a key word of culture, the word must be common, frequent, must be part of phraseological phrases, proverbs and sayings. In other words, in order to recognize this or that word as a concept (the key word of culture), it is necessary for the word to become common, frequent. In addition, a necessary condition for the recognition of a word as a concept is its entry into the phraseological and paremiological, proverbial and verbal fund of the language. Linguistic norms can be correlated with cultural attitudes. It is worth noting, however, that they are not as binding as the norms of the language. Bearers of culture, distributed in different societies, have the right to a wider choice.

So, culture lives and develops in a "linguistic shell". If earlier primitive cultures were "material", material, then modern ones are becoming more and more verbalized. Language serves culture, but does not define it. Language is capable of creating verbal illusions (in other words, stereotypes) that replace reality. The creation of social stereotypes becomes possible thanks to verbal illusions (from Lat. Verbalis – oral, verbal). An example is the existence of such national stereotypes as "German", "Chukchi", "persons of Caucasian nationality", which form national prejudices based on conversations around a person, the sound of speech. As a result, verbal clichés are being introduced into the minds of people that paint the world in the "desired color": a bright future, great indestructible friendship of peoples, great achievements, etc. It is thanks to language that a person perceives fiction as reality, experiences and comprehends what does not exist in reality, suffers and enjoys, experiences catharsis (the process and result of a purifying, facilitating and ennobling effect). All this is possible only thanks to natural language, as well as other semiotic systems (the language of cinema, the language of forms, colors, sign language, i.e. kinesics, etc.). The leading place among all these languages as sign systems is occupied by natural language, since a linguistic sign can become an indicator of culture.

Observations show that it is rather difficult to determine to the end what language and culture are, in what relations they are with each other and how great their role is in the life of a person and society. We have only tried to indicate how important it is to understand the relationship between language and culture at the present stage.

Thus, it becomes obvious that language and culture are inextricably linked, and the concept is the connecting link between them. In this regard, the concepts should be considered in the context of such





areas as intercultural communication, teaching foreign languages, translation, international politics, diplomacy, since knowledge of the cultural characteristics of certain concepts reflected in the language will avoid misunderstandings and conflicts, which, in turn, will improve the quality of communication between ethnic groups. After all, language is one of the most powerful social tools that unites people into an ethnos. Through the storage and transmission of culture, social identity and traditions of a particular speech community, the language forms a nation. The fact is that, even if they speak the same language, people cannot always correctly understand each other, and the reason for this is often precisely the divergence of cultures [1; 6].

In the context of the contrast of cultures, the success and effectiveness of intercultural communication depends on a number of factors of general, global action and on the actual content of communicative acts. The first (factors of global action) determines the motivational and factual moments. Such factors include a predisposition to communication or its absence, determination of the goals of communication, its strategy and tactical behavior during communication, entry into communication, etc. The second (the content of communicative acts) implies the fact that the communicants belong to different linguocultural communities. This factor affects both the social aspects of intercultural communication and the interpersonal communication of representatives of different ethnic groups and cultures. It is worth paying attention to the fact that it is unacceptable to believe that the above factor exists in the minds of only unenlightened "naive communicants". Extensive communicative experience and educational work in the field of intercultural communication lead only to the erasure of interlanguage and intercultural boundaries and the understanding that people belonging to another ethnic group, others, to the recognition of the right to exist for others, but not to the disappearance of the very differences of linguistic cultures.

Recently all over the world there has been an increased interest in cultural problems, in the study of cultures of different peoples, and especially cultural conflicts. However, behind this explosion of interest in the cultures of other peoples, according to S.G. Ter-Minasova, there are not creative and noble goals and interests in the cultures of the world, not the desire to expand the horizons of one's own culture by enriching the experience, originality and originality of other cultures, but completely different reasons. As a result of the economic, political and social changes and upheavals that have taken place on a global scale in recent years, an unprecedented shift has occurred, which has entailed large-scale migration of peoples, and with this inevitable clashes

with the indigenous population, which, of course, leads to a conflict of cultures [12].

The conflicts that arose in connection with the misunderstanding, and therefore the rejection of a foreign culture, forced to pay the closest attention of the public and science to the problems of intercultural communication. True, the issues of intercultural communication are eternal, they have worried human society from time immemorial. So, in Ancient Greece and Rome, all foreigners and representatives of other cultures were called barbarians (from the gr. Barbaros). This word has an onomatopoeic nature, and it is associated with a foreign language; non-native languages were perceived by ear as an indistinct bar-bar-bar. This issue was also reflected in the proverb, which is in many languages of the world: *В чуждой монастырь со своим уставом не ходят* (Russian); *When in Rome, do as Romans do* (English). Thus, we can conclude that folk wisdom in each of these languages is trying to warn its people and thereby protect them from a possible conflict of cultures. Native culture here acts as a kind of shield that protects the national identity of the people, its originality. At the same time, it acts as a blank fence that separates the native culture from other, perceived as alien, cultures. Thus, the whole world is divided into two opposite poles: "ours" / "aliens", where "ours" are united by language and culture, which "aliens" do not know. Such an axiological value differentiation of "one's own" / "someone else's" is at the heart of human life. This explains the fact that in intercultural communication, we, first of all, inevitably encounter prejudices, presuppositions and evaluative stereotypes, which significantly affect the process of communication from its beginning to the end. The main factor for intercultural communication is the cultural, or otherwise, linguistic (semiotic) border. From the very beginning, this implies the existence of a "friend" / "alien" model of communication, which the communicants define for themselves and the interlocutor. The model of communication "ours" and "aliens" is not meant by the communicants as simply a change of roles in the dialogue. This communication model marks speech (language, culture) as something that is "beyond the border" of its culture and language. It does not take into account that the speech is conducted in one of the languages of the communicants themselves, or in an intermediary language, or with the assistance of an interpreter. In any of these cases, the communicants are faced with a foreign culture and mentality. Such a practice in communication with the use of the label "friend" / "foe" does not imply obligatory confrontation and aggressive confrontation. Very often, communicators are looking for common ground in the language and culture of their interlocutor in order to increase the effectiveness of mutual understanding and thereby achieve the most



successful communication. To this end, the communicants are trying to bring together the elements of the worldview predetermined by linguistic culture. Thus, we can come to the conclusion that in intercultural communication, a certain constant is the mutual recognition of the presence of a semiotic border.

The most vivid and obvious examples of unsuccessful intercultural communication and cultural clashes are the everyday communication of foreigners. Such conflicts become, at best, a source of anecdotes and curiosities, at worst – the cause of troubles and tragedies.

The problems of intercultural communication affect all spheres of human life in contact with other cultures. In particular, one-sided: when getting acquainted with foreign fiction, art, cinema and theater, radio and television, when reading foreign press, as well as in connection with the use of the most popular and widespread communication system in our time - the Internet. Unilateral contact with a foreign culture and the conflicts arising in connection with this are called indirect, indirect, in contrast to the direct conflict of cultures that occurs during real communication with representatives of other ethnic groups. With unilateral contact, the cultural barrier is practically invisible and unconscious, which, however, makes it even more dangerous. For example, when getting acquainted with foreign literature, the reader inevitably comes across a foreign culture, the culture of another, unfamiliar country and enters into conflict with it. Reading by foreign authors is, figuratively speaking, an act of invasion "into a foreign monastery." In the process of acquaintance with foreign literature, the reader inevitably evaluates a foreign culture and the world through the prism of his own worldview and worldview formed by the culture of his country, which entails a deeper awareness of the reader of his own culture, his world outlook and attitude to life and to people.

Summarizing all of the above, it becomes obvious that such a difficult situation poses the following tasks for science:

1. to conduct a thorough study of the roots, manifestations, forms, types, development and differences of cultures of different peoples, as well as their contacts;

2. to instill in people a sense of tolerance towards other cultures and ethnic groups.

To accomplish the above tasks, linguistics, along with other sciences, began to study concepts as a reflection of the worldview and worldview of various ethnic groups.

In the online encyclopedia "Krugosvet" the following explanation of the term "tolerance" is given: "Tolerance (tolerance) is the desire and ability to establish and maintain community with people

who differ in some respects from the prevailing type or do not adhere to generally accepted opinions" [18].

According to the Declaration of Principles of Tolerance, adopted by the General Conference of UNESCO (1995), "Tolerance means respect, acceptance and correct understanding of the rich diversity of cultures in our world, our forms of self-expression and ways of manifesting human individuality. It is harmony in diversity, it is a virtue that makes it possible to achieve peace and contributes to the replacement of the culture of war with a culture of peace ... " [4].

Tolerance is extremely important in the modern world, in an age of globalization and ever-increasing mobility, integration and interdependence, the rapid development of communication and interpenetration of cultures, in an age of large-scale migrations and a radical transformation of social structures. Human society is based on differences between people, due to which the escalation of intolerance and interethnic conflicts potentially threatens the whole world, and it is impossible to isolate oneself from such a threat by national borders.

An exceptionally close connection and interdependence is observed today between the teaching of foreign languages (including Russian as a non-native one) and intercultural communication, in connection with which the awareness and solution of issues of intercultural communication in modern linguodidactics is of particular importance. At each lesson, educational lesson in a foreign language, there is a contact and intersection of cultures, since every word in a foreign language is a mirror image of a foreign (alien) world and foreign culture. Every word conceals an idea of a different world, conditioned by the national consciousness of another ethnos.

The close connection and interdependence of languages and cultures and the obvious need for their co-study does not raise any doubts today. However, here it is necessary to make an important methodological remark: the essential features and differences of languages and, accordingly, cultures are manifested in a comparative analysis, in a comparative study of languages (respectively, and cultures). Integral and differential features of languages, as well as the cultural barrier, are not visible at the level of only one culture and language. The linguistic and cultural barrier becomes obvious, obvious only when the native culture collides with someone else's mentality and worldview of a different order, which differ from their own worldview. At best, these differences are perceived as surprising, but more often they are just strange, unpleasant and shocking.

This is where the concept of culture shock comes from. Enclosed in the framework of their own



culture, people are entrenched in the strong illusion of their own special vision of the world, mentality and way of life. This world and way of life are perceived as the only possible and the only acceptable.

However, the problem is that most people do not recognize themselves as a product of their culture, even if they understand that the behavior of representatives of other ethnic groups is determined by their other culture. This means that no one considers it necessary to change anything in their consciousness. The problem of intercultural communication can be solved only by going beyond the framework of your culture. In other words, only when faced with a different worldview, attitude, etc. you can understand the specifics of your social consciousness and see with your own eyes the difference or conflict of cultures.

Thus, it becomes quite clear that the cultural barrier is much more unpleasant and dangerous than the linguistic one, and it is not felt until a person encounters this barrier, invisible until a certain moment. The danger of intercultural communication also lies in the fact that language mistakes are not perceived as painfully as cultural mistakes, despite the fact that people are more lenient about a person's ignorance of a foreign culture, since cultural differences are not generalized into sets of rules: cultural issues are not issued dictionaries as in the language. Language mistakes of foreigners related to interference, accent, etc., as a rule, are met by native speakers with a smile, while cultural mistakes often produce a much more unpleasant impression.

The human essence lies in the understanding only of what is already known and understood, rather than the knowledge of the new. After all, communication systems, including language, to a certain extent were created out of fear of the unknown undividedness of the surrounding world. And the known, designated and dismembered world is reproduced in daily discourses as its own non-aggressive and comfortable world.

## REFERENCES

1. Vereshhagin E.M., Kostomarov V.G. *Jazyk i kul'tura: Lingvostranovedenie v prepodavanii ruskogo jazyka kak inostrannogo*. – Moskva: Russkij jazyk, 1983. – 246 s.
2. Bartminskij E. *Jetnocentrizm stereotipa: rezul'taty issledovanija nemeckih (Bohum) i pol'skih (Ljublin) studentov v 1993-1994 gg. // Rechevye i mental'nye stereotipy v sinhronii i diahronii*. – Moskva, 1995. – S. 7-9.
3. Gumbol'dt fon V. *Jazyk i filosofija kul'tury*. – Moskva: Progress, 1985. – 448 s.
4. *Deklaracija principov terpmosti: Utverzhdena rezoljuciej General'noj konferencii JuNESKO ot 16 nojabrya 1995 g. [Jelektronnyj resurs]*. – Rezhim dostupa: URL: <http://tolerance.ru/toler-deklaracija.php> (data dostupa: 16.06.2021).
5. El'msl'ev L. *Prolegomeny k teorii jazyka / Per. s angl. / Sost. V.D. Mazo*. – Moskva: URSS, 2006. – 248 s.
6. Karasik V.I. *Jazykovej krug: lichnost', koncepty, diskurs*. – Volgograd: Peremena, 2002. – 477 s.
7. Levi-Stross K. *Strukturnaja antropologija*. – Moskva: Izdatel'stvo Jeksmo-Press, 2001. – 512 s.
8. Maslova V.A. *Lingvokul'turologija*. – Moskva: Akademija, 2001. – 208 s.
9. Sepir Je. *Izbrannye trudy po jazykoznaniju i kul'turologii*. – Moskva: Progress, 1993. – 655 s.
10. Serebrennikov B.A. *O materialisticheskom podhode k javlenijam jazyka*. – Moskva: Nauka, 1983. – 319 s.
11. Tarasov E.R. *Jazyk i kul'tura: Metodologicheskie problemy // Jazyk – Kul'tura – Jetnos*. – Moskva: Nauka, 1994. – S. 105-112.
12. Ter-Minasova S.G. *Jazyk i mezhkul'turnaja kommunikacija*. – Moskva: Izdatel'stvo Moskovskogo gosudarstvennogo universiteta, 2004. – 352 s.
13. Tolstoj N.I. *Jazyk i narodnaja kul'tura: Očerki po slavjanskoj mifologii i jetmolingvistike*. – Moskva: Indrik, 1995. – 262 s.
14. Tolstoj N.I., Tolstaja S.M. *O zadachah jetmolingvisticheskogo izuchenija Poles'ja // Poleskij jetmolingvisticheskij sbornik*. – Moskva, 1983. – C. 3-21.
15. Tolstoj N.I. *Jetmolingvistika v krugu gumanitarnyh disciplin // Russkaja slovesnost'. Ot teorii slovesnosti k strukture teksta. Antologija*. – Moskva: Academia, 1997. – S. 306-315.
16. Uorf B.L. *Otmoshenie norm povedenija i myshlenija k jazyku // Novoe v zarubezhnoj lingvistike*. – Moskva, 1960. – Vypusk I. – S. 135-168.
17. Hajms D.H. *Dva tipa lingvisticheskaj odnositel'nosti // Novoe v zarubezhnoj lingvistike*. – Moskva: Progress, 1975. – Vypusk VII. – S. 229-298.
18. *Jenciklopedija «Krugosvet» [Jelektronnyj resurs]*. – Rezhim dostupa: URL: [https://www.krugosvet.ru/enc/gumanitarnye\\_nauk/filosofiya/TOLERANTNOST.html](https://www.krugosvet.ru/enc/gumanitarnye_nauk/filosofiya/TOLERANTNOST.html) (data dostupa: 10.06.2021).



# SAVITRIBAI PHULE THE FIRST LADY TEACHER AND SOCIAL REFORMER IN NINETEENTH CENTURY OF INDIA

Sourav Chandra Garaian<sup>1</sup>, Dr. Subir Sen<sup>2\*</sup>

<sup>1</sup>Research Scholar, Sidho-Kanho-Birsha University, Purulia, West Bengal, 723104, India

<sup>2</sup>Associate Professor, Sidho-Kanho-Birsha University, Purulia, West Bengal, 723104, India

\*Corresponding Author: Dr. Subir Sen

Article DOI: <https://doi.org/10.36713/epra7439>

DOI No: 10.36713/epra7439

## ABSTRACT

*Savitribai Phule was an important social reformer and leading character of the then Maharashtra. She was the first lady teacher of first girl's school in India. Not only a teacher she was a great social reformer. In nineteenth century she was a power source of woman education and woman empowerment. She was also a founder of modern Marathi poetry. At this crisis time she and Jyotirao Phule established a girl's school with nine students in 1848 at Pune in Bhide Wada and she also taught in this school. She did not stop there, she raised her voice against the practice of child marriage, sati pratha and child widows for the betterment of the human race and society. At the same time, she promoted a positive attitude towards widow remarriage. She was an idol of Dalit and Mang community like Bhimrao Ramji Ambedkar. She also moved against untouchability and rule out the discrimination grounded on caste and gender.*

## INTRODUCTION

Savitribai Phule was born on 3<sup>rd</sup> January, 1831 in Naigaon village, Satara district in Maharashtra. Her parents were Lakshmi Bai and Khandoji Nevse Patil. She got married with Jyotirao Phule (Mahatma Jotiba Phule) in the age of 9 in 1840. Jyotirao Phule was also a great thinker, writer, social activist and anti-caste social reformer. Savitribai Phule and Jotirao Phule had no own children. They adopted a Brahmins widow child. The name of that child was Yashawant Rao. Savitribai Phule started schooling after her marriage. Because of her interest in studying, Jyotirao Phule insisted her to start educating herself. After clearing the exam of third and fourth year from a normal school she became interested about teaching. After that she took training to nurture her skills at Ms Farar's Institution in Ahmednagar. Jyotirao Phule was always standing and greatly supports all activities of Savitribai Phule. She with her husband makes many social services.

Savitribai Phule and Jyotirao Phule made many school for women education and low cast child. For this activity in 16 November 1852 honored the Phule family for their contributions in the ground of education by the British government. The Pune City Corporation built a memorial in 1983 to pay homage to her. Government of India released a postal stamp in her honor on March 10, 1998. In 2015 The University of Pune changed the name of the university and it was renamed as Savitribai Phule Pune University. Google create Google doodle to celebrate her 186th birth anniversary on January 3, 2017.

## LITERATURE REVIEW

**Katke, S. M. (2019)** Conducted a study entitled "Savitribai Phule Contribution towards Indian Social Elements – A Study"

In this study it was mentioned that Savitribai Jyotirao Phule was a famous Indian social reformer, educator,





and poet who played an active role in the education and empowerment of women in the 19th century. Savitribai is one of the few educated women of this time and is responsible for having founded the first girls' school in Pune, Bhide Wada, with her husband Jyotirao Phule. She went to great lengths to raise and emancipate child widows, opposed child marriage and Sati Pratha, and advocated the remarriage of widows. As a major protagonist of Maharashtra's social reform movement, she is considered an icon of the Dalit Mang caste along with B. R. Ambedkar and Annabhau Sathe. She campaigned against untouchability and actively campaigned for the abolition of caste and gender discrimination.

**Pandey, R. (2019)** Conducted a study entitled "Locating Savitribai Phule's Feminism in the Trajectory of Global Feminist Thought"

Feminism shows shades of the first wave of feminism when she talked about the ability to reason, self-reliance, and public schools. Her feminism showed traces of the second wave of feminism as she raised her voice over shelters and marriages between castes. Her feminism also showed some valuable characteristics of third wave feminism when she talked about raising women with different identities and bringing Stree Shudra Atishudra together. Savitribai was also the first woman to put her husband's stake in the whole history of India. Her decision to light her husband's pyre must have shocked the most radical feminists all the time.

**Mangala, K. D. (2018)** Conducted a study entitled "*Savitribai Phule: Revolutionary work and literature*"

In this study the important issues are Savitribai's educational thinking is an era promoter. Savitribai Phule can be proudly mentioned as a positive force that shapes the female life of Maharashtra. It is glad to say that Savitribai gave prestige to the woman because of Savitribai, a noble and revolutionary spectator of her personality and activities. This light of innovation is a motivation for women who have worked in various fields and proved their mettle. Savitribai's work was challenging the difficulty of the times, Because Savitribai thought and worked for the freedom of all women and the Shudratishudra society in the world of slavery in the then orthodox society of the nineteenth century. Krantijyoti Savitribai Phule's position as a champion of the downtrodden and a supporter of teaching is inevitable in the wake of India's first teacher women's liberation movement. Phenomenal Education is a instrument for social transformation. He wanted to generate awareness in the society through education. Savitribai Phule was one of the immense educators of India who laid down the basic idea of education for

humanity about 175 years before. Savitribai Phule's social and educational work is amazing and phenomenal. At the same time, Savitribai also produced literature. Her literature was enlightening the society. His entire literature was on social awareness. All literature was for the welfare of the citizens.

**Jain, S. (2016)** Conducted a study entitled "Caste and Education: The Vision of Mahatma Jotirao Phule"

There major findings are the ideologies the ideologies of the anti-caste movements were geared towards the "emancipation" that all intellectuals needed for Dalits. Phule was the first anti-caste intellectual to think about education for the masses (for Dalits). He fought against Brahmanism, which is "superstition, bag of tricks, weapon of domination" (Omvedt, Dalit Visions 8). Phule is not only considered the main figure of the anti-caste movement, but also a protester for the empowerment of women His wife, Savitribai Phule, is the main contributor to the education mission for oppressed women. According to Jyotirao Phule, the education of women and the lower caste deserves priority as their social position and condition in society are greatly degraded.

**Somkuwar, P. (2014)** Conducted a study entitled "*Dalit Women Poets and New Themes in Poetry*"

Major issues discussed in this work are as follows Dalit literature in the hands of modern women's writers has gone through a multidimensional revolutionize. Adjudging new themes and concepts it hardly remains the literature of lower classes. These modern poets writing is not only the writing of lamentation, breast-beating, praising or even consideration but also feministic, reflective and universal. By representing universal themes in their text, they have taken the movement of Dr Ambedkar on a high peak. Their society as well as Dalit Writers from first and second generations has sky-scraping hopes from these Modern Dalit Women poets. Finally all discussion indicates to the quote Dr Ambedkar who said, "I measure the progress of the community by the degree of progress which women have achieved.

**Wolf, T. (2011)** Conducted a study on Savitribai Phule.

It is opined that for present day, every literate woman of India, anywhere in the world, stands as testimony to the influence of the four original and extraordinary ideas shared by Comenius and Savitribai: that education for every child, without exception, must be universally accessible, child sensitive, intellectually critical, and socially reforming. And every girl child, in any school, on any day, in India sitting at the side of boys, reading a book, exploring the Internet, learning





new things. It is a Savitribai-kind of India. Might just such a different arrangement incite a future with a different kind of social structure a world venue learning place different from the detention center house kind of culture within which Savitribai lived? If so, then I don't know the children of India may yet sing in a pleasant house, little canaries freed into a most original and extraordinary future a Comenius and Savitribai kind of future.

### **ROLE IN WOMEN EDUCATION & EMPOWERMENT**

Savitribai Phule is famous for her massive involvement towards empowerment and emancipation of women through education and for the elimination of slavery and inequity on the grounds of religion, caste and race. To make this thinking a reality Savitribai Phule and Jyotirao Phule established a girl's school with nine students in 1848 at Pune in Bhide Wada. For this step both faced the rejection by the society. At this dangerous situation a friend Usman Sheikh and his sister Fatima Sheikh extended a helping hand. They also handed over their accommodation to start school. Savitribai Phule became first teacher in this school. In this school included western curriculum of social studies, mathematics and science. After that to fight against untouchability Savitribai Phule and Jyotirao Phule start another school for children from the Mang and Mahar castes in 1852. In the year of 1852, in Pune, Savitribai Phule and her husband established three different schools for girls. In these three schools total 150 students were enrolled. Over the year Savitribai Phule starts total 18 school for educating women, children as well as other people from different downtrodden castes. All those social activities became an eyesore for the upper castes of Pune. They opposed educating lower castes or dalits. Savitribai Phule was too much harassed and humiliated by the upper castes peoples. They throw Cow dung, mud and stones on Savitribai Phule. but she remained stand on her goal and she and her husband started an evening school for the different day laborers and farmers.

The revelation of all aspects shows that Savitribai Phule was a feminist or social reformer who established the base of women's education in India when there was full of orthodoxy, strict caste division and superstition about 180 year ago. She also raised her strong voice against child marriage, feticide, cast discrimination etc. This was a very exemplary event in India at that time. Later, great thinkers like Dr. Bhimrao Ramji Ambedkar, Rabindranath Tagore and Swami Vivekananda were also expressed similar thoughts on women education and empowerment.

About two years before the birth of Savitribai Phule, Raja Ram Mohan Roy, with the help of Lord Bentinck, abolished the crucial practice of satidaha pratha in 1829. Then in 1856, under the initiative of Ishwar Chandra Vidyasagar, the Widow Marriage Act got official approval. Ishwar Chandra Vidyasagar also set up a total of 38 women's education centers in West Bengal in 1858, which was a contemporary of Savitribai Phule. That is to say, the auspicious effect of the voice raised by Savitribai in Maharashtra entered West Bengal through the hands of Ishwar Chandra Vidyasagar and later Dr. Bhimrao Ramji Ambedkar, Rabindranath Tagore, Swami Vivekananda spread it all over India and the world, as a result of which today's improved society.

### **ROLE AS SOCIAL REFORMER**

Savitribai Phule inaugurated the Mahila Seva Mandal to make women awareness about their rights, self-respect and other social issues. She was done many social activities to protest the traditional narrow-mindedness about widows. After that Savitribai Phule and Jyotirao Phule started a care centre for pregnant Brahmin widows and pregnant rape victims name Balhatya Pratibandhak Griha.. In this care centre they helped deliver and save their children, For this wonderful movement it possible to prevent infanticide. At this time Savitribai Phule and Jyotirao Phule adopt a child from a Brahmin widow called Kashibai. This adoption sends a great message to society. Not only that Jyotirao Phule works about widow re-marriage and against the child marriage and sati pratha. After that in 1897 Savitribai Phule and her adopted son, Yashawant Rao starts a clinic at pune to care for those affected by the Pandemic of the bubonic plague in the region around Nalasopara. In this pandemic situation everybody left but Savitribai Phule did not hesitate to fight against the crisis situation. She even gave up her life to fight in this pandemic situation.

### **ROLE AS AUTHOR AND POET**

Savitribai Phule was a pronounced author and poet. She wrote Kavya Phule (1854) and Bavan Kashi Subodh Ratnakar (1892) and also wrote a poem entitled "Go, Get Education". Through these publications she was try to encourage and motivate women and lower cast's peoples and also tries to encourage and motivate who opposed her works and contribution to the society. Every one of her works was carried out for the welfare of the society and woman education. On the other hand Jyotirao Phule was also a great thinker, writer. he wrote Tritiya Ratna in 1855, Brahmananche Kasab in 1869,



Gulamgiri in 1873, Sarvajanic Satya Dharmapustak in 1891 etc. He also summarizes Savitribai Phule.

### Award and Honor

In 16 November 1852 honored the Phule family for their contributions in the ground of education by the British government and acknowledged as Savitribai Phule was the best teacher. On the other hand to show respect a monument was formed in her honor by the Pune City Corporation in 1983. After that India Post released a stamp in her honor on 10th March, 1998. In 2015 The University of Pune changed the university name and it was renamed as Savitribai Phule Pune University. On 3rd January, 2017 Google create Google doodle to celebrate her 186th birth anniversary.

### Demise

When Savitribai Phule and her adopted son, Yashawant Rao starts a clinic at pune and Yashawant Rao served valuable service as a doctor for the suffering people in the bubonic plague at this time Savitribai Phule took the effected people to the clinic where her son treated them. She caught the Plague while trying to serving the son of Pandurang Babaji Gaekwad and she died a heroic death to it on the 10th of March, 1897.

### CONCLUSION

Savitribai Phule a name that was closely associated with women education and equal rights. In the 19<sup>th</sup> century saw the beginning of spread of women education mainly by Savitribai Phule. Not only education, she also helped women and lower cast's peoples to live with their heads held high in the society. She was a social reformer as well as qualified teacher. She was such a woman whose main purpose was to educate the entire human race. And she set up many schools to meet those purpose. Not only the nation or the country but the whole world is grateful to his for all these social welfare and educational works. The path shown by her is the beginning of women education and another fighter like B R Ambedkar in reducing racial inequality in India.

### REFERENCES

1. Bhattacharyya, J. (2015). Swami Vivekananda's Ideal of Universal Religion. *Multidisciplinary Journal of Humanities and Social Sciences*. Vol 2, pp 1-8.
2. Gupta, A. K. (2019). *Vidyasagar in popular perception: Recovered through anecdotes*. SAGE Publication. Vol 6, pp 23-32.
3. Jain, S. (2016). *Caste and Education: The Vision of Mahatma Jotirao Phule*. BRDU International

*Journal of Multidisciplinary Research*. Vol 1, pp 19-32.

4. Katke, S. M. (2019). *Savitribai Phule Contribution towards Indian Social Elements – A Study*. *Journal of Emerging Technologies and Innovative Research (JETIR)*. Vol 6, pp 25-32.
5. Mangala, K. D. (2018). *Savitribai Phule: Revolutionary work and literature*. *Indian journals.com*. Vol 5, pp 71-75.
6. Pandey, R. (2019). *Locating Savitribai Phule's Feminism in the Trajectory of Global Feminist Thought*. *Indian Historical Review*. Vol 46(1), pp 86-105.
7. Roy, K. (2010). *Rabindranath Tagore Literacy Giant with scientific bent*. *Science Reporter*. Pp 36-39.
8. Somkuwar, P. (2014). *Dalit Women Poets and New Themes in Poetry*. *International Journal of English and Literature (IJEL)*. Vol 4, pp 41-48.
9. Singh, L. N. *Life and Times of Mahatma Jyotirao and Krantijyoti Savitribai Phule*. pp 1-9.
10. Sircar, J. (2020). *Rammohun Roy: His contribution to the making of India*. SAGE Publication. Vol 7, pp 53-64.
11. Sirswal, D. R. (2013). *Mahatma Jyotiba Phule : A Modern Indian Philosopher*. pp 1-12.
12. Varshaa, K. and Vezhaventhan, D. (2018). *A study on view of dr.babasaheb ambedkar in formation of modern India*. *International Journal of Pure and Applied Mathematics*. Vol 120, pp 281-296.
13. Wolf, T. (2011). *Changing Education: A Note on the "Original and Unusual" Worldvoice, Worldview, and Worldvenue of Jan Comenius and Savitribai Phule*. *Journal of Applied Christian Leadership*. Vol 5, pp 1-27.



# STUDY ON SUSTAINABLE CARPET TILE FLOORING IN 5-STAR HOTEL OF INDIA

Ayushi Jain<sup>1\*</sup>, Ar. Sweta Choudhary<sup>2</sup>

<sup>1</sup>PG Student, Sustainable design, Vivekananda Global University, Jaipur, Rajasthan (India)

<sup>2</sup>Associate Professor, Vivekananda Global University, Jaipur, Rajasthan (India)

Article DOI: <https://doi.org/10.36713/epra7447>

DOI No: 10.36713/epra7447

## ABSTRACT

*Sustainable development is a rapidly growing area of focus for many interior design professionals. The hospitality sector of the world's economy is growing. The environmental design of hotels can reduce the environmental impacts of growing tourism development. Interior designers can help influence this lasting movement through a suitable selection of interior finish materials that both meet the needs of our customers and could support this enduring commitment to change.*

*The focus of this paper is to study the carpet tile floors used in hotels. The purpose of this study is designers' important elements when highlighting the hotel with always design to consider evaluating floor materials for use.*

*Research articles related to the design of the hotel have also been analyzed. The results of the material analysis shows that the design of a hotel Good consumers feelings, self-brand links, satisfaction, preference, intentions of behavior and loyalty, beauty employees can affect enjoyment and well-being. Other contributions to hotel design Successful at business employment levels, maintenance costs, sales, increased efficiency, higher total operating profits, reduced capital and reduced investment need. The design of the hotel is also closely linked to stability.*

## INTRODUCTION

Sustainable development can be defined as development that meets the needs of the present without compromising on the ability of future generations to meet their own needs.

To have an effect on static stabilization. "Focus on planning from the point of view of the communication system of the Internet environment, solutions for the inter floor environment and for the environment, which are subjects for the interaction of the atmosphere and life". The weather may try to be updated at the same time in the weather. The tourism sector of the world economy is growing. The environmental design of hotels can reduce the environmental impacts of rapid tourism development. Interior designers can help influence this sustainable movement through the appropriate selection of interior finish materials that both meet the needs of our clients and support this enduring commitment to change. The focus of this paper is to study the carpet tile flooring used in hotels. The purpose of this study is to define the benefits of carpet tiles for designers and to shed light on the important elements to consider when evaluating flooring materials for use in hotels with sustainable designs.

Hotel design is closely related to sustainability as well. As a designer we need to finalize good durable flooring material for hotel space.

## CARPET TILE FLOORING

### 1. CARPET TILE FLOORING?

Carpet tiles are small swatches of big carpet, made from broadloom carpet, that can be installed and combined in a number of creative ways. Also known as "modular carpets" & "carpet squares", carpet tiles are most often square and available in a range of square sizes – 48 x 48, 50 x 50, 60 x 60 and 96 x 96cm. Some manufacturers, however, also offer carpet tiles in a variety of creative shapes. They are equipped with all comfortable facilities.



**Figure 1 CARPET TILES**

## **2. BENEFITS OF CARPET TILE FLOORING**

### **2.1. THEY ARE MODULAR**

These carpet tiles are 4 times more efficient as compared to broadloom carpet. Modular tiles are not only easy to fit, they are much easier to store.



**Figure 2 INTERLOCKING CARPET TILES**

### **EASE OF INSTALLATION**

One of the main reason architects and designers – not to mention floor fitters – choose to work with carpet tiles is the ease with which they can be installed. Let's find out how Carpet can make your installation easier:

- Carpet tiles are easy to pick up and transport, which makes it easy to get them to the work site without getting damaged in the first place.
- Carpet tiles, because they are pre-backed, can be installed directly over the subfloor, eliminating the need for an underlay. It saves a lot of time and effort not to mention money.
- Carpet tiles do not always need to be adjusted, or set in place, for 24 hours before laying.
- While absolutely not recommended, carpet tiles can also be placed alongside furniture in situations where time is of the essence.

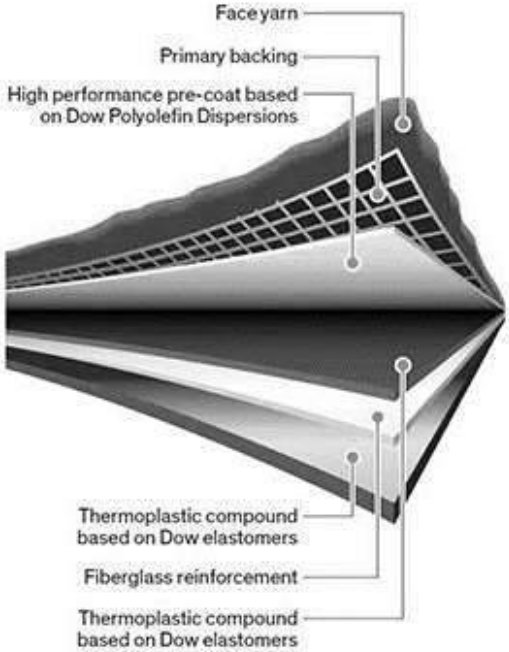




**Figure 3 CARPET TILE INSTALLATIO**

**2.2. THEY ARE SUSTAINABLE**

Sustainability is an increasingly important consideration for architects and designers, as well as the clients they design. Because of the minimal waste that carpets tiles create in installation, choosing them for your design means you are already on your way to sustainability. On top of that, they are recyclable, olefin-based raw materials for backing to help create "free-to-" carpeting (eg, Phthalate-free, Polyvinyl Chloride (PVC)-free, Bitumen-free, Styrene-free).



**Figure 4 DECONSTRUCTED CARPET TILE**



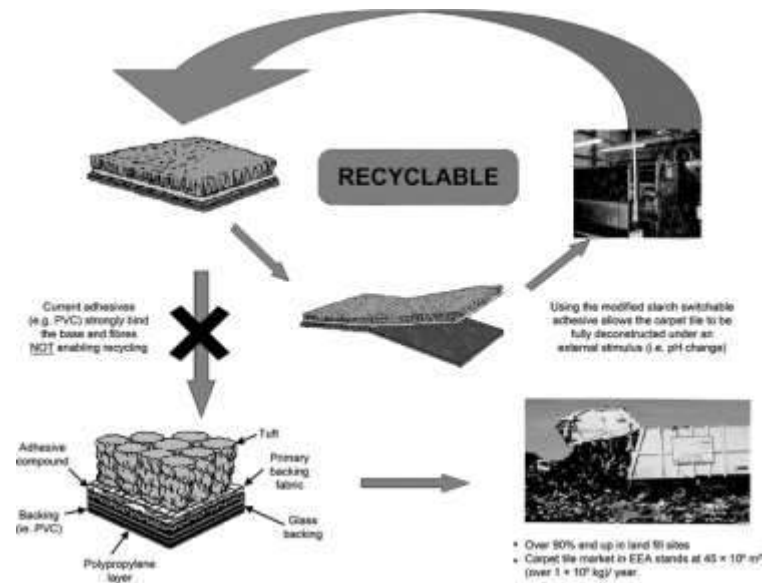


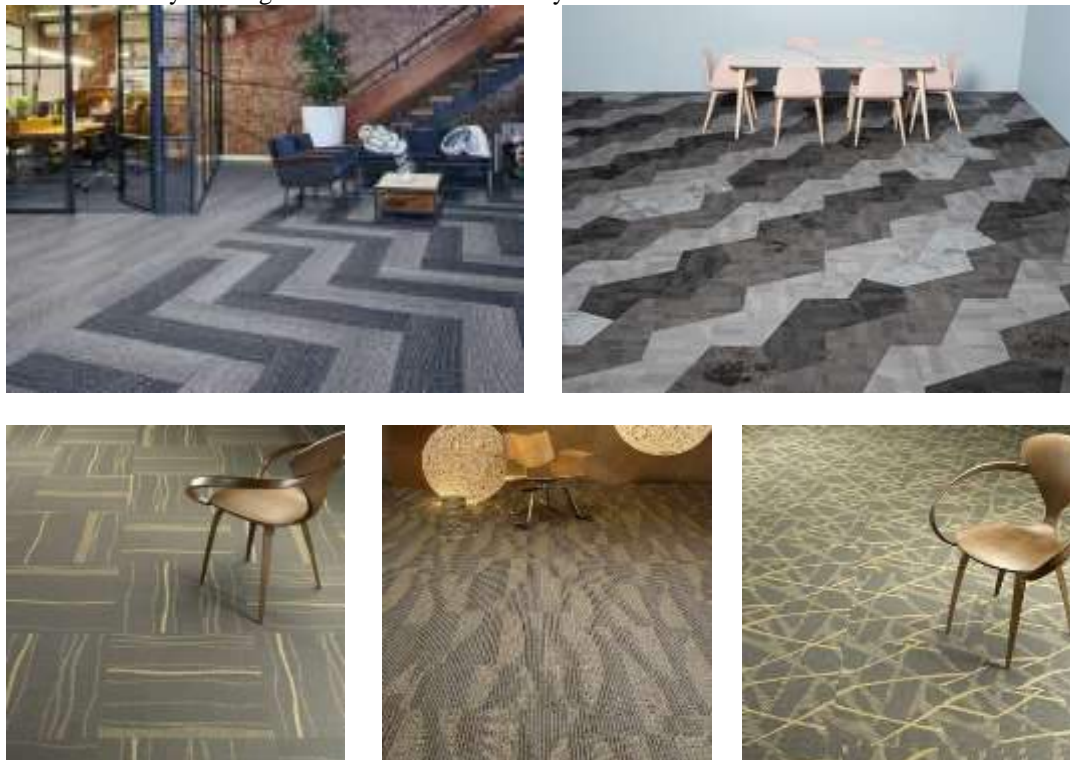
Figure 5 RECYCLABLE CARPET TILE

### 2.3. THEY ARE DURABLE

We do our Color Fastness Test (a test designed to use color changes due to light and wear on the surface of the carpet), the Castor Chair Test (to simulate the effect of Castor chairs used in commercial spaces on carpets) designed test) go beyond standard wear and tear testing. Vetterman Drum Test (test designed to simulate continuous moving traffic).

### 2.4. THEY ARE VERSATILE

Individual tiles can be easily replaced if damaged, or if you just want a change. They're also easy to mix and match - so you can get creative and work tile-by-tile.



### 2.5. THEY PROVIDE INDOOR AIR QUALITY

Indoor air quality has been proven to affect the health, well-being and productivity of the people living in a space. Breathe easily with carpet that protects against the growth of mold, mildew and other odor-causing microorganisms.

### 2.6. THEY OFFER GOOD ACOUSTICS

Soundproofing flooring is the ideal solution for reducing the impact of noise in any space, and at Interface, we design our products with acoustics in mind.



**Figure 6 DESIGN OF CARPET TILES AS PER ACOUSTICS**

### 2.7. THEY ARE CHEAP

Together, all these benefits make carpet tiles excellent value for money.

### 2.8. LOW MAINTENANCE

With carpet tiles, maintenance is simple. Tiles can be cleaned with normal spot cleaning, and can be easily replaced if excessively soiled or destroyed. To stay on top of maintenance efforts, however, you and your customer will need to figure out which areas of the carpet will be most affected by heavy dirt and create a plan to address these areas.



**Figure 7 CARPET TILE CLEANING**

### **2.9. GENERATE LESS WASTE**

Carpet tiles generate minimal waste at the fitting stage. This is because very little cutting, or adjustment, is required to fit the tiles in a certain location. This is especially true for rooms with many nooks and odd angles.

You can expect a wastage of around 1-3%. Less waste means less money to spend, but is also attractive to customers concerned about sustainability.

### **3. CARPETS AND RUGS ARE USED AT FOLLOWING PLACES:**

1. banquet halls 2. Hotel lobby 3. Corridors 4. Presidential suites 5. Vice-presidential suites 6. Villas 7. Resort's restaurants





**Figure 8 JW MARRIOTT HOTEL BANQUET HALL, JAIPUR**

#### 4. CARPET CAN AFFECT YOUR LEED APPLICATION HOW

Sustainable Carpets can add credit to your application with the US Green Building Council (USGBC), the organization that developed the LEED certification and which works to promote sustainable construction policies nationwide.

Carpeting can play a major role in the overall sustainability of your project. Think about the amount of surface area of your building that is covered by floors – this is a big part of your project, so, of course, the carpet you choose will have a significant impact on the eco-friendliness of your building.

Although the USGBC does not certify building materials, sustainable carpet can add credit to your LEED application if it is made from recycled materials, locally sourced, and/or made from low-emission materials.



Figure 9 USGBC LEED LOGO

#### 5. PRICE ON INDIAMART

- Thickness - 6 - 8 mm
- Color - Multi
- Size - 600mm X 600mm
- Price - ₹ 50/ Square Feet- ₹ 100/ Square Feet (Jaipur, Rajasthan)

#### CONCLUSION

There are many sustainable carpet options stemming from recycled materials.

When people think of green flooring options, sustainable hardwood, bamboo and cork are often some of the first materials that come to mind. However, carpet can be a great eco-friendly solution, and choosing the right carpet can also increase the LEED application of your building.

They are made in lots of colours and patterns so you can create your own unique designs. Plus, the installation is simple and a great DIY project. You can also install wall-to-wall carpet tiles, which is a bit more challenging.

Carpet tiles, sometimes called carpet squares, come in modular sizes such as 18" x 18" and 24" x 24" that are ideal for creating geometric patterns, and many manufacturers make half- and quarter-size tiles. Huh. so that you make your own design.

#### REFERENCES

1. [https://www.interface.com/IN/en-IN/Products-IN/Carpet-tile/Carpet-Tiles-Benefits-en\\_IN](https://www.interface.com/IN/en-IN/Products-IN/Carpet-tile/Carpet-Tiles-Benefits-en_IN)
2. <https://www.heritagecarpets.sg/project/india-jaipur-jw-marriott-hotel-banquet-hall-project/>
3. <https://blog.egecarpets.com/explore/everything-you-need-to-know-about-carpet-tiles>





## HUMAN RESOURCE PLANNING IN AN INDIAN CEMENT INDUSTRY: A DIAGNOSTIC STUDY

<sup>1</sup>Ms. Jeevana Chitreddy, <sup>2</sup>Prof.G.L. Narayanappa

<sup>1</sup>Research Scholar, Dept. of Management, Dravidian University, Kuppam

<sup>2</sup>Dean, School of Commerce and Management, Dravidian University, Kuppam

Article DOI: <https://doi.org/10.36713/epra7432>

DOI No: 10.36713/epra7432

### STATEMENT OF THE PROBLEM

The 'ABC' Cement Industries Ltd has entrenched in the year 1955 in the most economically disadvantaged and industrially deprived location of Southern India. After words, the industry nourished as a very big cement industry in the region. Subsequently, the founders put their sustained efforts to emerge the ABC industry as a market leader. From the past half decade the company was creating thousands of employment opportunities to the unemployed youth in the region. At the outset the ABC cement industry produced only 200mts per day and later it has increased its production to 4000 TPDs after contraption. The then dynamic founder entrepreneur under whose custodianship the ABC cement industry was flourished, such founder was passed away and the industry is looked after by their heriditaries.

### IMPORTANCE OF HUMAN REESOURCE PLANNING

The era of economic liberalisation and privatisation around the globe have been drastically streamlined the industrial sector in general and the cement industries in particular. The cement industry enormously encourages the growth of Indian economy during the cut-throat competition of industries.

The object of this study includes the importance of human resource management factors which influence the role of human resource planning to assess the nourishment of future economy of cement industry. It is realised that there is a need of convergence of human resource planning in cement industries for overall upward advancement of cement industries in today's corporate world. Since, the advent of liberalisation with an object of moulding

the cement industries sector more human resource oriented and expansion of the role of cement industries in the growing economy and the role of privatisation and the direct foreign investment have given the boost to the modern cement industry. The ABC Cement Industries Limited has realised the relative importance of human resource planning for deputing their vital employees for world class institutions for training in H.R. planning programmes of employees.

With the changing technology taken place in administration of cement industries, the designing of new corporate human resource plans, keeping in view of the ever changing human resources requirements of cement industries has become arduous task. In view of this catastrophic situation, the ABC cement industry should compile the new human resource plans with thousand eyes.

Further, it is realised that the analysis of specifications for future H.R. needs of this cement industry is inevitable. In addition, it is also noticed from the incidents of past era that the improper and unscientific H.R. planning resulted in attracting the mismatch of human resources for the cement industry. In spite of several attempts made by the ABC cement industry with regard to the H.R. planning, several disruptions were taking place in attaining the proper implementation of this facets. Hence, the principle aim of HRP is overall augmentation of the productivity of the organisation.

In the era of globalisation, the success of cement industry very much depends upon the adoption of scientific H.R. planning methods by the ABC cement industry. The practices of rational and scientific HRM indicates that particular organisation is initiating efforts for grabbing the market leadership. Hence, adoption of scientific H.R.



planning procedure for their employees is inevitable for ABC cement industry towards the maximisation of profits.

### REVIEW OF LITERATURE

Randal (2005)<sup>1</sup> has viewed that the human resource planning is the cycle that comprises of creating and executing plans and projects to guarantee that the correct number and kind of people are accessible at the perfect time and spot to satisfy hierarchical requirements.

Imison Buchan and Xavier(2009)<sup>2</sup> have claimed that getting the balance right between labor demand and supply is the most well known objective of the human resource planning.

Izueke (2009)<sup>3</sup> has expressed that for strictly speaking, we should call this function "Human resource planning and activity programming" furthermore human resource planning requires definite investigation analysis of the present and the function to ensure that the organization has the correct number of individuals accessible who have the correct sorts and skills to perform the duties required by the organization when the work is needed.

Ulfertsm et al.,(2009)<sup>4</sup> has opined in adopting HRP, an organization its present labour force to decide its future labour force needs and recognizes the gaps between the future and the present based on its organizational strategic objectives.

Colley and Price (2010)<sup>5</sup> have identified an embracing and essential way to deal with HRM and stated that the HRP can be utilized to make an interpretation of organization strategic objectives into HR strategic and to coordinate with individuals to the essential strategic necessities of an organization in both the short term and long-term.

Dwevedi (2012)<sup>6</sup> noticed the human resource planning as a process which assist in appropriately performing of human resource functions such as valid and timely date which is given about when to do revenue sales production level.

### SCOPE OF THE STUDY

The scope this study is confined to the H.R. Planning practices of 'ABC' Cement industries and it can not be made any generalisation to other similar industries

### OBJECTIVES OF THE STUDY

The basic objectives of the study:

- (i) To explore the customary practices of human resources planning in ABC Cement Industries Ltd;
- (ii) To appraise the level of satisfaction/dissatisfaction of

employees/workers towards the customary practice of human resource planning in ABC Cement Industries Ltd.;

- (iii) To look out the factors for dissatisfaction of employees/workers towards the customary practice of human resource planning in ABC Cement Industries Ltd. And;

- (iv) To bestow the suitable remedial measures to surmount the discontentment prevailed among the employees/workers towards the customary practice of human resource planning in ABC Cement Industries Ltd.

### RESEARCH METHODOLOGY

The methodology consists of data collection from primary as well as secondary sources. Through the survey method the first hand information was collected from 60 sample respondents from the study unit.

### SAMPLE DESIGN AND SIZE

A Purposive-cum-convenient sampling procedure was followed and 60 respondents were chosen as sample respondents.

### ANALYSIS OF THE DATA

The information collected from the sample respondents was processed and tabulated scientifically and several statistical tools like (i) Independent sample t-test; (ii) Weighted mean scores; (iii) ANOVA; and (iv) Correlation analysis are calculated at appropriate junctures and the inferences were drawn

### RESEARCH FINDINGS

- 1) Due importance is not given for organisational requirements while imparting training and while deputing the employees/workers to the various employee training programmes. Deputation of employees to the various training programmes is purely depends on the whims and fancies of higher officials. Really deserving and eligible employees/workers are not at all deputing for employee training programmes. (21.66%)
- 2) The very design of training is not designed in accordance with the needs of the organisation and hence there is a mismatch between the skills required by the organisation and the actual skills imparted in the training (23.33%).



- 3) The present training procedure is not at all imbibing any new skills to the employees/workers/participants to discharge updated technological professional responsibilities which involve certain technical knowledge. Whenever any technological problems arised in the operation of the plant and machinery the organisation needs to depend on outside technological experts which involves huge-expenditure (18.33%).
- 4) The present employee training programmes are not at all motivating the work attitude, professional conduct and character of the employee/workers. Due to this reason, the professional working performance of the employees/workers was not at all enhanced (16.66%).
- 5) The present programmes of employee training are not at all helping to develop the organisational performance and also not playing any vital role in enhancing the employees' calibre and organisational productivity 20.00%).

## SUGGESTIONS

1. It is suggested that a rational and scientific correlation should be created between H.R. Plans and organisational plans. So that the H.R. Planners would be able to analyse the human resources requirements for the specific section needs and organisational requirements of the human resources. Hence, there would not be any scope for diversion of the services of H.R. Planning experts to general organisational requirements. Creation of such scientific correlation between H.R. Plans and organisational plans can specifically avoid the mismatch of H.R. experts between H.R. Planning department and organisational planning.
2. For preparation of H.R. Plans an experienced and highly educated person like M.B.A (HRM) or M.M.S IHRM) graduate with 10 to 15 years experience in the field must be appointed as a H.R. Manager. Further, a sub-team of personnel numbering 4 to 6 persons must be appointed under his directorship. This H.R. Manager is expected to prepare the H.R. Plans in a rational and scientific manner. The sub-team would assist him from time to time in compilation of rational and scientific plans. Further, the sub-team would be trained under his superior direction and would be able top

support the organisation in further contingencies of human resources.

3. The duration of the present H.R. Plans is only 3 years which is a very short span for planning. Hence, it is suggested that the duration of each H.R. Plan must be at least 5 years. During this period H.R. Planning reviews can be carried out at the end of every year. So that the H.R. Planners would be able to know how many employees are retiring every year, how many new personnel are required and how many deaths are happening. Based on this authentic and accurate information the organisation can assess the accurate human resources need and prepare long term and authenticated H.R. Plans.
4. At the outset the H.R. Managers should analyse and assess the immediate future human resources needs of the organisation followed by long terms needs of the organisation. While analysing and preparation of H.R. Plans a proper and scientific correlation between H.R. Plans and H.R. needs of the organisation should positively be created. So that the preparation of crippled and irrational H.R. Plans can be wiped out.
5. First of all, the 'ABC' Cement Industry should formulated prudential and scientific H.R. policies for strengthening its H. R. Planning activity. Under the guidance and direction of an experienced H.R. expert the proposed H.R. polices should be fabricated under his control. While preparation of H.R. Plans the proposed H.R. expert should take into consideration certain important aspects such as (i) attracting of qualified and experienced personnel; and (ii) minimisation of absenteeism and employee turnover.

## REFERENCES

1. *Randall, S. (2000), Human Resource Planning, Vikas Publishers, New Delhi India.*
2. *Imison, C., Buchan, J., & Xavier, S. (2009). NHS Workforce Planning. Limitations and Possibilities. London: The King's Fund.*
3. *Izueke, E. M. (2009). "Strategic Human Resources Management in the Nigerian Public Service and the Millennium Development Goals (MDGs): The Nexus" in Nigerian Journal of Public Administration and Local Government. Vol Xiv, No 1 & 2, 2009.*
4. *Ulfertsm, G., Wirtz, P., & Peterson, E. (2009). Strategic human resource planning in academia. American Journal of Business Education, 2(7), 1-9.*



5. Colley, L., & Price, R. (2010). *Where have all the workers gone? exploring publicsector workforce planning. Australian Journal of Public Administration*, 69(2), 202-213. doi: 10.1111/j.1467-8500.2010.00676.
6. Dwivedi, R.S. (2012). *A text book of human resource management. Vikas Publishing. New Delhi, India.*



# PARENTAL INVOLVEMENT IN HOME VISITATION: ITS RELATION TO STUDENTS PERSONAL DEVELOPMENT AMIDST THE PANDEMIC

**Emily Christine O. Mañosca**

*Faculty, Paaralang Sekundarya ng Lucban Integrated School*

Article DOI: <https://doi.org/10.36713/epra7392>

DOI No: 10.36713/epra7392

## ABSTRACT

*This study was conducted to determine the Parental Involvement in Home Visitation: Its Relation to Students' Personal Development Amidst the Pandemic. Specifically, it sought to answer the following questions: What is the level of parental involvement in-home visitation in terms of parental support and parenting style? What is the level of student personal development amidst the Pandemic in terms of emotion, mental and social? Is there a significant relationship between parental involvement in home visitation its relation to student personal development amidst the Pandemic?*

*The research design used in this study was descriptive method of research because it answers basic questions about what is happening in a defined population and it utilized quantitative approach in gathering necessary data from the respondents.*

*The respondents were composed of Grade 7 students of Paaralang Sekundarya ng Lucban Integrated School, Lucban District, Division of Quezon. The Student were sought to answer the self-made checklist questionnaire prepared by the researcher. Mean, Standard Deviation and Correlation Analysis were applied as statistical test to achieve the objectives. The population of the study was 559 Grade 7 Students; random sampling technique was employed in selecting eighty (80) students from the 11 sections of Grade 7, (7) students for every sections. The result showed a moderate relationship between parental involvement in-home visitation through parents' support ( $r=0.565$ ,  $p=0.000$ ) and parenting style ( $r=0.577$ ,  $p=0.000$ ) with student emotional development. Such a relationship Is found highly significant as manifested by the probability values of 0.000, which are both lower at 0.01 significance level, there is a moderate relationship between parental support in-home visitation through parent support ( $r=0.515$ ,  $p=0.000$ ) and parenting style ( $r=0.587$ ,  $p=0.000$ ) with student mental development. Such a relationship is still significant as manifested by the probability values of 0.000 which are both lower at the 0.01 significance level, weak relationship between parental support in-home visitation through parent support ( $r=0.394$ ,  $p=0.000$ ) and parenting style ( $r=0.379$ ,  $p=0.001$ ) with student social development. Such a relationship is still significant as manifested by the probability values of 0.000 which are both lower at the 0.01 significance level. It means there was a significant relation to student personal development between parental involvement in home visitation amidst the pandemic.*

*Based on the findings of the study, it is concluded that the student personal development has a relation between parental involvement in home visitation amidst the pandemic. It is crucial that the parents actively share responsibilities in the pandemic because it positively impacts the students' academic achievements, especially the child's behavior. The researcher highly recommends that: teachers' may conduct home visitation as a tool to check on the well-being and personal development of the students when the general level of the community quarantine allows it; parents may communicate with the teacher through different online messaging platforms or through text messaging during times when home visitation is not allowed by the level of the community quarantine; students may have established good communication with their teachers, especially those encountering difficulties adjusting to the new normal education system, and may use different platforms of communication; home Visitation may be conducted depending on COVID Risk Severity Classification and compliance with minimum health standards. Always observe the latest updates and guidelines of IATF in conducting home visitation; future researchers are encouraged to do further studies emphasizing the variables in the present studies.*

## INTRODUCTION

According to the UN Declaration on the Rights of the Child (1959) in Principle 7, the child is entitled to receive a quality education, free and compulsory, at least in the elementary stages. All children have a right to access free, quality education

to develop their abilities, individual judgment, and sense of moral and social responsibility to become effective members of society. The responsibility of the parents is to guide the child in his education, support the child financially, emotionally, mentally, and physically. Parents should explain the





importance of education so that the child gains interest in his education.

In the last few months, the country is facing an economic crisis due to the Pandemic (Covid-19). Many people face different problems, and the most affected in this situation is the children's education. The Department of Education finds ways to continue education amidst the Pandemic and the learning modality in the New Normal is Modular Distance Learning (MDL). In modular distance learning, parents are the partners of teachers in education; they are the home facilitator. The primary role of the parents in modular distance learning is to establish a connection and guide the child properly. Parents and children encounter different problems such as difficulty answering the assigned task in the module, difficulty understanding the topics in the modules, difficulty submitting modules on time, and other students lacking the motivation to accomplish different tasks.

As per DepEd Order no. 032 s. 2020 Section I. Rationale No. V. Procedures E. Health and Safety Protocols, Secondary School Teachers abiding by the required health and safety protocols may continuously include home visitation as part of the duties. Parents are recommended to actively participate in the home visitation to help the learners to adjust to the new learning modalities.

Based on page 8 of the guidelines for areas placed under general community quarantine by the IATF No. 11a, the Basic Education Learning Continuity Plan of the Department of Education is adopted. Home Visitation may be conducted depending on COVID Risk Severity Classification and compliance with minimum health standards. Using home visitation, teachers shall observe and understand the child's behavior and the parents as well. In-home visitation teachers gather more information regarding the family background and status of the learner, and it is an excellent way to understand challenges faced by the learner through home visitation.

This study was conducted to give insight to parents and students about the importance of parental involvement in home visitation: its relation to student personal development amidst the Pandemic, and to attempt to offer a solution.

## RESEARCH METHODOLOGY

This study employed quantitative method research design in gathering necessary data. Descriptive-correlation design because correlation

design is a statistical technique that can show whether and how strongly pairs of variables are related McCombes (2019). Descriptive research aims to accurately and systematically describe a population, situation, or phenomenon, and it includes a purpose and a question. It is the most basic research design; it answers basic questions about what is happening in a defined population.

The respondents of the study consisted of Grade 7 students in Paaralang Sekundarya ng Lucban Integrated School, Lucban, Quezon. The respondents of this study were composed of 80 selected grade 7 students.

The researcher used simple random sampling to selected Grade-7 Students in Paaralang Sekundarya ng Lucban Integrated School. In getting eighty (80) respondent from the 11 sections of grade-7, seven (7) from the section of Einstein, seven (7) from the section of Wisdom, seven (7) from the section of Love, seven (7) from the section of Hope, seven (7) from the section of Faith, seven (7) from the section of Honesty, seven (7) from the section of Peace, seven (7) from the section of Humility, seven (7) from the section of Courage, seven (7) from the section of Courteous, seven (7) from the section of Charity, three (3) from the section of Ohsp. Equal chances were given to them so that the data was not biased and was reliable.

The main instrument used in the study was a questionnaire formulated by the researcher. The questionnaire is composed of 2 sets. Each set contains seven items. The questions consisted of statements used to determine parental involvement in home visitation: its relation to student personal development amidst the Pandemic. The questionnaire was the primary tool to identify the Parent Involvement in Home Visitation: Its Relation to Student Personal Development Amidst the Pandemic. It is an efficient way to obtain information from some students. The Likert Scale was used for the interpretation of the values of the gathered data. After collecting the necessary data, descriptive and inferential statistics were administered. The data summary gathered from the respondents with the use of tables and text and to explain what the tables were showing. The quantitative results cover the interpretation and explanation of quantitative result and determining the relationship between independent and dependent variable.



## STATISTICAL TREATMENT

The following statistical tools were used in treating the data gathered by the researcher.

Statement of the Problem	Statistical Treatment
1. What is the level of Parental Involvement in Home Visitation in terms of: Parental Support and Parenting Style?	Weighted Mean and Standard Deviation
2. What is the level of Student Personal Development amidst the Pandemic in terms of: Emotion, Mental and Social?	Weighted Mean and Standard Deviation
3. Is there a significant relationship between parental involvement in home visitation its relation to student personal development amidst the Pandemic?	Correlation analysis

## RESULTS AND DISCUSSIONS

**Table 1. Level of Parental Involvement in Home Visitation in terms of Parental Support**

Indicative Statement	Mean	SD	Verbal Interpretation
1. Thru home visitation my parent participates in school.	4.46	0.64	Very High
2. By means of home visitation, my parent motivates me to do well.	4.49	0.62	Very High
3. Since the home visitation is conducted, my parents are willing to support in different problems I encounter.	4.33	0.63	Very High
4. My parents understand the difficulty I am experiencing in the learning process, but by means of conducting home visitation, my parents are willing to guide me.	4.45	0.67	Very High
5. Thru home visitation, my parents give feedback about my performance.	4.40	0.63	Very High
6. In conducting home visitation, my parents listen attentively when discussing my performance and willing to help me.	4.35	0.68	Very High
7. By means of home visitation, my parent is willing to have teamwork and collaboration regarding my performance.	4.30	0.68	Very High
<b>Overall Mean</b>	<b>4.40</b>		<b>Very High</b>

### Legend:

- 4.20 – 5.00 Very High
- 3.40 – 4.19 High
- 2.60 – 3.39 Moderate
- 1.80 – 2.59 Low
- 1.00 – 1.79 Very Low

It could be gleaned from the table the level of parental involvement in-home visitation in terms of parental support. Results show that by home visitation, parents motivates to do well describes as *very high* ( $M=4.49$ ,  $SD=0.62$ ); employing home visitation parents participates in school it was interpreted as *very high* ( $M=4.46$ ,  $SD=0.64$ ) through parental involvement in home visitation the parents able to participates in the school-related activities; parents understand the difficulty being experienced in the learning process is *very high* ( $M=4.45$ ,  $SD=0.67$ ). Likewise the respondents, *very highly* agree thru home visitation, parents give feedback about the performance of the learner ( $M=4.40$ ,  $SD=0.63$ ), the parents listen attentively when discussing their performance and willingness to help them regarding their performance and was interpreted as *very high* ( $M=4.35$ ,  $SD=0.68$ ); the willingness of parents to support in different problems encounter is very high

needed ( $M=4.33$ ,  $SD=0.63$ ); as parents, the willingness to have teamwork and collaboration regarding school performance was *very high* essential ( $M=4.30$ ,  $SD=0.68$ ) by this the learners are motivated to do well.

The overall mean of 4.40 further shows that parental involvement in-home visitation as to their support is very high. Small standard deviation values in almost all indicators show that students have almost the same or common perception concerning parents' support. The parental support in-home visitation establishes communication between the teacher, parents, and the child to see the positive outcome on the student performance.

The findings were supported by Untevero (2013) as cited by Cabriga (2014), parental support deals with the participation of parents in school and even in the life of their child. Through parental support, the child motivates to accomplish different



tasks. Also, through home visitation, parents become aware of the performance of the children in school. After the home visitation, parents are eventually supporting their child. Parental support has an impact on the performance of the child. Through parental support in-home visitation, the children develop a lifelong love of learning.

According to Khan et al. (2011), parental support has a positive impact on children's education. It also creates self-confidence for the child. Using home visitation, parents become responsive to the child's development; parental support is the best way to build a strong relationship between parents, children, and teachers. This strong relationship can help students in developing self-confidence that can

lead to becoming better people. Parental support is the best way to create a positive environment for every child.

It is construed that parental support in home visitation positively impacts the child's performance in school, like increasing academic achievement, improving behavior, and impacting a child's personality. Through home visits, it can establish better communication between the parents, child, and students, and it can also motivate parents to get involved in the child's performance in school. Parents also try their best to become more involved in the child's development, especially in academic performance in school that parental support gives positive outcomes in the child.

**Table 2. Level of Parental Involvement in Home Visitation in terms of Parenting Style**

Indicative Statement	Mean	SD	Verbal Interpretation
1. Thru home visitation, my parents become responsive to my needs.	4.38	0.72	Very High
2. By means of home visitation, my parents explain to me about their expectations.	4.21	0.67	Very High
3. In conducting home visitation, my parents provide comfort when I am upset.	4.28	0.73	Very High
4. Thru home visitation, my parents encouraged me to talk about my thoughts and feelings	4.29	0.66	Very High
5. Using home visitation, I am aware that my parent guides me when I make an important decision.	4.41	0.69	Very High
6. Thru home visitation, my parents encouraged me to explain my views and opinions.	4.29	0.66	Very High
7. Utilizing home visitation, my parents give compliments.	4.21	0.69	Very High
<b>Overall Mean</b>	<b>4.29</b>		<b>Very High</b>

**Legend:**

- 4.20 – 5.00 Very High
- 3.40 – 4.19 High
- 2.60 – 3.39 Moderate
- 1.80 – 2.59 Low
- 1.00 – 1.79 Very Low

In terms of Parenting style, the respondents perceived *very highly* needs that thru home visitation, the parents will guide the child in making an important decision ( $M = 4.41, SD = 0.69$ ); parents are *very highly* become responsive in their needs ( $M = 4.38, SD = 0.72$ ); parents encourage the child to share thoughts and feelings ( $M = 4.29, SD = 0.66$ ) with described as *very high*; through the home, visitation parents is *very highly* encouraged the child to explain their views and opinions ( $M = 4.29, SD = 0.66$ ); in conducting home visitation the parent is *very highly* needed to give and provide comfort when the students are upset ( $M = 4.28, SD = 0.73$ ), it is *very highly* needed that parents explain their views and opinions ( $M = 4.21, SD = 0.67$ ); by means of home, visitation parents is *very highly* give compliments ( $M = 4.21, SD = 0.69$ ).

The overall mean of 4.29 indicates that parental involvement in-home visitation regarding their parenting style is very high. Small standard deviation values in almost all indicators show that students have almost the same or common perception with regard to parenting style. Thus, parenting style can improve the behavior of the child to become an independent individual.

The findings were supported by Abesha (2012) as cited by Alison (n.d.). The parenting style has a positive outcome for the children when it comes to school performance, and it is also visible in the child actors on how the children interact with other people. Parenting style is important because it supports healthy growth and development. The way that the parents interact with the children and how the



parents discipline the child will impact the rest of the children's lives.

In addition, as cited by Arceta (2016), they consistently keep an eye on, manage, and use non-inflicting methods or discipline when rules are violated. Through parenting style, parent care, and protecting the child from harm, parent enforced boundaries for children to be guided through their actions.

To sum it up, parents influence influences the behavior of their children through their specific practices. Parenting style builds a healthy growth and development of children also it develops strong emotional bonds that can help the children to manage their feelings, behavior and can develop self-confidence this self-confidence can help the children perform well in whatever task is given.

**Table 3. Level of Student Personal Development in terms of Emotion amidst the Pandemic**

Indicative Statement	Mean	SD	Verbal Interpretation
1. I understand what emotion I feel in the sudden change of learning modality because of the pandemic.	4.30	0.68	Very High
2. I understand that I encounter a financial crisis due to the Covid-19 Pandemic that affects my academic performance.	4.18	0.71	High
3. Most of the time, I feel worn out because of many activities to be accomplished.	4.06	0.75	High
4. In times of the Covid-19 Pandemic, my parents support me in my performance in school.	4.45	0.65	Very High
5. My parent guides me when the problem occurs because of the difficulty in the learning process due to pandemic.	4.34	0.69	Very High
6. I feel motivated when there is a difficult task to be accomplished.	4.18	0.76	High
7. I am aware of my emotions due to the New Normal System of Education.	4.21	0.72	Very High
<b>Overall Mean</b>	<b>4.24</b>		<b>Very High</b>

**Legend:**

- 4.20 – 5.00 Very High
- 3.40 – 4.19 High
- 2.60 – 3.39 Moderate
- 1.80 – 2.59 Low
- 1.00 – 1.79 Very Low

In terms of emotion, the respondents perceived *very highly* important in times of the covid-19 pandemic they feel that parents support them in school performance ( $M=4.45$ ,  $SD= 0.65$ ). Parents guide their children when the problem occurs ( $M= 4.34$ ,  $SD= 0.69$ ) described as *very high*. Likewise, students understand their emotions because of the sudden change of learning modality because of pandemic ( $M= 4.30$ ,  $SD= 0.68$ ) described as *very high*. Due to new normal system of education student is *very highly* aware of their emotion ( $M=4.21$ ,  $SD= 0.72$ ). The students understand that financial crisis encounters due to the covid-19 pandemic can affect the academic performance ( $M=4.18$ ,  $SD= 0.71$ ) describes as *high*. Students are *highly* motivated if they accomplish a difficult task ( $M= 4.18$ ,  $SD= 0.76$ ) because they feel happy when they finish the task given to them. Students *highly* feel worn out because of lots of activities to be accomplished ( $M= 4.06$ ,  $SD= 0.75$ ). In times of pandemic, students face difficulty.

The overall mean of 4.24 indicates that students' personal development regarding their emotional attributes is very high. Small standard deviation values in almost all indicators show that students have almost the same or common perception regarding their emotions. The emotional attributes affect the student's personal development, but with the proper guidance of their parent, they face different problems that they will encounter.

This was supported by the study of Teruel et al. (2020), who stated that students suggested feeling motivated because of the factors that will lessen the emotional effects in the stressful events due to the changes of environment, and the sudden covid-19 pandemic encountered. Covid-19 pandemic gives emotional consequences on the students because of the sudden change of learning modalities, but with the proper guidance of their parents in the new normal system of Education, they motivate their children to adopt the changes brought by the current situation to the covid-19 pandemic.



The result was supported by the study of Pajarianto (2020). Academic stress caused by study at home during the pandemic Covid-19 can be outdone by maximizing student religiosity, teacher support, and parent support at home. The following supports gave by the teacher and parents can lessen the emotional stress to the student because they motivate to accomplish a different task that is given to them, even learning at home because of the current situation due to the covid-19 pandemic.

In conclusion, parents in this time of covid-19 pandemic can help the child lessen emotional stress because of the current situation caused by the covid-19 pandemic. Parents should act as a source of strength for the child to lessen the effects of trauma

and by helping each other to establish a safe and supportive environment for learning. Also, the teacher should develop differentiated instruction for the students in connecting the curriculum that suits their interests and providing them to showcase their knowledge and skills in different platforms that can demonstrate their learnings. The different instructional material will catch the student's attention, and the students will be able to accomplish the different tasks given to them because they quickly learn by having differentiated instructions made by the teachers. Despite the imposed situation because of the covid-19 pandemic, students must be aware of different challenges they encounter, and students show enthusiasm towards their learning.

**Table 4. Level of Student Personal Development in terms of Mental amidst the pandemic.**

Indicative Statement	Mean	SD	Verbal Interpretation
1. I can follow instructions while having difficulties in the learning process due to the current situation.	4.30	0.72	Very High
2. I learn to make my own decision regarding my academic performance while learning at home because of the pandemic.	4.10	0.82	High
3. I can face any situation when the problem occurs due to a pandemic.	3.91	0.81	High
4. My parents help me to think of a solution to own problems I encounter creatively.	4.20	0.64	Very High
5. Due to the current situation, I know my responsibility in whatever task is given to me.	4.20	0.79	Very High
6. My parents help me to motivate myself to do things well despite the current situation.	4.46	0.67	Very High
7. Despite the pandemic, my parents set a goal to be accomplished	4.34	0.71	Very High
<b>Overall Mean</b>	<b>4.22</b>		<b>Very High</b>

**Legend:**

- 4.20 – 5.00 Very High
- 3.40 – 4.19 High
- 2.60 – 3.39 Moderate
- 1.80 – 2.59 Low
- 1.00 – 1.79 Very Low

In terms of mental attributes, parents help them motivates them to do things well, despite the current situation ( $M= 4.46, SD= 0.67$ ) describe as *very high*. Despite the pandemic, parents are *very highly* set goals for the children to accomplish a different task ( $M= 4.34, SD= 0.71$ ). Students follow instructions despite difficulties in the learning process due to the covid-19 pandemic ( $M= 4.30, SD= 0.72$ ) describes as *very high*. Parents help them to think for the solution for their own problems they encounter creatively ( $M= 4.20, SD= 0.64$ ) with a descriptive rating of *very high*. Because of the current situation, the student knows their responsibilities in the task given to them ( $M=4.20, SD= 0.79$ ) describes as *very high*. Likewise, students are *highly* making their own decision regarding academic performance while learning at home because of pandemic ( $M=$

4.10,  $SD= 0.82$ ). Meanwhile, they can face situations *highly* when a problem occurs due to a pandemic ( $M= 3.91, SD= 0.81$ ).

The overall mean of 4.22 indicates that students' personal development as to their mental attributes is very high. Small standard deviation values in almost all indicators show that students have almost the same or common perception regarding their mental attributes. The current situation brought by pandemics affects the student in making decisions with the guidance of their parents; they can manage to make their own decision.

This was supported by the study of Zhai et al. (2020) that the college student encounters challenges on mental health due to Covid-19. The government should seek urgent support for the challenges faced by the student; through this,





students can adopt the changes they encounter due to pandemics.

The finding was supported by Liu et al. (2020) that the covid-19 pandemic has an impact on college students due to new learning modality in the new normal set-up, to lessen the mental stress of the students, parent, as well as teachers, promote different types of support to ensure the mental health

of the students that can affect their personal development, but by means of home, visitation parents will be much aware in different challenge encounter by the student.

The statement above shows the mental attributes of the students due to the covid-19 pandemic student needs to adapt to changes in the New Normal System of Education.

**Table 5. Level of Student Personal Development in terms of Social amidst the Pandemic**

Indicative Statement	Mean	SD	Verbal Interpretation
1. My parent encourages to get along with a variety of people.	4.03	0.86	High
2. Even in the current situation, my parents encouraged me to share my thoughts and ideas clearly with others.	4.18	0.69	High
3. Despite the pandemic, my parents help me to pay close attention when someone is talking to me, especially when it comes to school matters.	4.29	0.75	Very High
4. In the current situation, peer and my family are an essential factor to improve my performance.	4.44	0.69	Very High
5. Despite pandemic, I can read between lines in every situation I am facing.	4.29	0.66	Very High
6. I can learn easily with peers.	3.95	0.90	High
7. Even in current situation my parent encourages me to have a collaboration with my peers thru online communications.	4.10	0.72	High
<b>Overall Mean</b>	<b>4.18</b>		<b>High</b>

**Legend:**

- 4.20 – 5.00 Very High
- 3.40 – 4.19 High
- 2.60 – 3.39 Moderate
- 1.80 – 2.59 Low
- 1.00 – 1.79 Very Low

In terms of social attributes, the peer and family are the important factor to improve the performance in school ( $M= 4.44$ ,  $SD= 0.69$ ) described as very high; the parent need to help their children to pay close attention when someone is talking, especially in school matters ( $M= 4.29$ ,  $SD= 0.75$ ) described as *very high*; students can read between two lines in every situation they are facing ( $M=4.29$ ,  $SD=0.66$ ) with a descriptive rating of *very high*; they *highly* encourage their child to share their thoughts and ideas clearly with others ( $M= 4.18$ ,  $SD= 0.69$ ); even in the current situation parents *highly* encourage their children to have a collaboration with their peers thru online communication ( $M= 4.10$ ,  $SD= 0.72$ ); parents *highly* encourage to get along with the variety of people ( $M= 4.03$ ,  $SD= 0.86$ ); students *highly* learn easily with peers ( $M= 3.95$ ,  $SD= 0.72$ ).

The overall mean of 4.18 indicates that students' personal development as to their social attributes is high. Small standard deviation values in almost all indicators show that students have almost the same or common perception with regard to their

social attributes. This current situation because of the covid-19 pandemic affects the socialization of the students with their peers, but there are lots of different platforms on how they can easily get along with, aside from this, peer and family are important factors to the personal development of the child.

As backed up by the study of Arnado et al. (2020), close family ties and peers play an important role in their mental development. This means that family and peers serve as an inspiration of the students that can help students boost their confidence in making their own decisions and facing different challenges they encounter because of the current situation due to the covid-19 pandemic.

Furthermore, Kazerooni et al., (2020) stated that in the university students in Iran developed an online peer platform, 71%. This new normal set-up help student to lessen the challenges they are facing. Peers can help the student to motivate them, especially in their academic performance.

To sum it up, peer relationship is an essential factor in student personal development



amidst pandemic, using different platforms can help students interact apart from academic learning.

### Relationship between Parental Involvement in Home Visitation and Student Personal Development in terms of Emotional Attributes.

**Table 6. Significant Relationship between Parental Involvement in Home Visitation and Student Personal Development in terms of Emotional Attributes**

Indicator	r	Interpretation	p	Analysis
Parental Support	0.565	Moderate	0.000	Significant
Parenting Style	0.577	Moderate	0.000	Significant

*Adjusted R<sup>2</sup> = 0.3751*

The study shows a moderate relationship between parental involvement in-home visitation through parents' support ( $r=0.565$ ,  $p=0.000$ ) and parenting style ( $r=0.577$ ,  $p=0.000$ ) with student emotional development. Such a relationship is found highly significant as manifested by the probability values of 0.000, which are both lower at 0.01 significance level. Subjected to simple regression analysis to determine the adjusted  $R^2$ , as both indicators were found highly significant, it shows that 37.51% of the student's emotional development variance is explained by the variance of the parental involvement in home visitation parental support and style.

Borup et al. (2015) stated that there is emotional feedback in times of covid-19 pandemic. The guidance of the parents in times of covid-19 pandemic plays an important role in easing the emotional stress of the students. It shows that it has a positive effect on the child's academic performance in school.

Carbonel, Banggaan & Agbisit supported the result (2013) the emotional behavior of the child affects the academic performance of the students but with the support of their parents, especially in the school academic progress of their child. This shows that being academically aware of the parents in the child's performance in school can help the student motivation to do well.

From the above statement, the parents play an important role in child emotional development; the parents should continuously guide and support their child to whatever decisions they will make, by the proper guidance of the parents, the child can express and manage feelings and parental involvement in home visitation influences the emotional development because child motivates to face different challenges they encounter and the achievement of the child is visible in the academic performance of the child while in the new normal system of education.

**Table 7. Significant Relationship between Parental Involvement in Home Visitation and Student Personal Development in terms of Mental Attributes.**

Indicator	r	Interpretation	p	Analysis
Parental Support	0.515	Moderate	0.000	Significant
Parenting Style	0.587	Moderate	0.000	Significant

*Adjusted R<sup>2</sup> = 0.3553*

Results show that there is a moderate relationship between parental support in-home visitation through parent support ( $r=0.515$ ,  $p=0.000$ ) and parenting style ( $r=0.587$ ,  $p=0.000$ ) with student mental development. Such a relationship is still significant as manifested by the probability values of 0.000 which are both lower at the 0.01 significance level. Subjected to simple regression analysis to determine the adjusted  $R^2$ , as both indicators were found highly significant, it shows that 35.53 % of the student's mental development variance is explained by the variance of the parental involvement in home visitation parental support and style.

This was supported by Minn et al. (2020) mental development of a person has the biggest effect,

especially in the changes of the learning modality in the new normal system of Education, but in spite of parental support in-home visitation, students learn to accept the changes and continue to improve their performance in school.

To sum up, parental involvement in home visitation plays a vital role in the continuous improvement of the students. Parental support and parenting style the students come actively engage in solving their problems in these current situations. Through parental involvement, the students assume an independent role in the learning process, and they are continuously responsible.



**Table 8. Significant Relationship between Parental Involvement in Home Visitation and Student Personal Development in terms of Social Attributes**

Indicator	r	Interpretation	p	Analysis
Parental Support	0.394	Weak	0.000	Significant
Parenting Style	0.379	Weak	0.001	Significant

Adjusted  $R^2 = 0.1582$

The study shows a weak relationship between parental support in-home visitation through parent support ( $r=0.394, p=0.000$ ) and parenting style ( $r=0.379, p=0.001$ ) with student social development. Such a relationship is still significant as manifested by the probability values of 0.000 which are both lower at the 0.01 significance level. Subjected to simple regression analysis to determine the adjusted  $R^2$ , as both indicators were found highly significant, it shows that 15.82% of the student's social development variance is explained by the variance of the parental involvement in home visitation parental support and style.

Base on the study of Chen et al. (2020), peer support can help to lessen anxiety and stress during a pandemic; with the proper guidance and support of their parents in the current situation, students can ease the stress and anxiety in times of pandemic.

The findings also supported by Andrews et al. (2020) that the proper supervision and support of the parents using different platforms impact online support with their peers and could help the students gain attention in the learning process.

To sum it up, parental involvement and parenting style in-home visitation impact the social development of the child; with this, they can easily learn to gain attention and motivate them to do well. Therefore, the null hypothesis was rejected.

## CONCLUSION

Based on the data gathered, it shows that the null hypothesis stating that "There is no significant relationship between parental involvement in-home visitation and its relation to student personal development amidst the pandemic was rejected. There was a significant relation to student personal development between parental involvement in home visitation amidst the pandemic. It is crucial that the parents actively share responsibilities in the pandemic because it positively impacts the students' academic achievements, especially the child's behavior.

## RECOMMENDATION

Based on the findings and conclusions of the study, the following recommendations are hereby given:

1. Teachers' may conduct home visitation as a tool to check on the well-being and personal development of the students when the

general level of the community quarantine allows it.

2. Parents may communicate with the teacher through different online messaging platforms or through text messaging during times when home visitation is not allowed by the level of the community quarantine.
3. Students may have established good communication with their teachers, especially those encountering difficulties adjusting to the new normal education system and may use different platforms of communication.
4. Home Visitation may be conducted depending on COVID Risk Severity Classification and compliance with minimum health standards. Always observe the latest updates and guidelines of IATF in conducting home visitation.
5. Future Researchers are encouraged to do further studies emphasizing the variables in the present studies.

## REFERENCES

1. Abesha (2012) "Reconceptualization of the authoritarian parenting style and paternal control: Some initial items." Retrieved November 13, 2016, from <https://orders.edrs.com/members/sp.cfm?AN=ED403015>
2. Alison, A. (2016) *Parenting Styles and Decision-Making of Grade VI Pupils: Correlation.*
3. Andrade, David (2015). *The Importance of Communication in Education.* Retrieve from Online on 15/08/2015 <http://www.techlearning.com/blogentry/8716>
4. Andrews, J. L., Foulkes, L., & Blakemore, S.-J. (2020). Peer influence in adolescence: Public-health implications for COVID-19. *Trends in Cognitive Sciences*, 24(8), 585–587. <https://doi.org/10.1016/j.tics.2020.05.001>.
5. Aristovnik Aleksander, Damijana Keržič, Dejan Ravšelj, Nina Tomažević and Lan Umek (2020), *Impacts of the COVID-19 Pandemic on Life of Higher Education Students: A Global Perspective* <https://doi.org/10.3390/su12208438> 13 October 2020
6. Arceta, M. (2016) *Parenting Styles and Its Influence on the Socio-Emotional Aspects of Intermediate Pupils.*
7. Arnado, Jeric Anthony S., Rogelio P. Bayod (2020). *Help Seeking Behavior of Young Filipinos Amidst Pandemic: The Case of Cor Jesu College Students*



8. Baumind, D. "Current Patterns of Paternal Authority." *DEVELOPMENTAL PSYCHOLOGY MONOGRAPHS* 4 (2010):1- 103. [https://hbzqezpst6kr/baumrind-parenting-style/retrieved from January 2016](https://hbzqezpst6kr/baumrind-parenting-style/retrieved%20from%20January%202016).
9. Bello, A., Pinson, M., & Tuliao, A. P. (2013, October). *The relationship of loss of face, stigma, and problem severity, on attitudes and intent to seek face-to-face or online counseling. Paper presented at the 50th Psychological Association of the Philippines and the 4th ASEAN Regional Union of Psychologists joint convention, Miriam College, Quezon*
10. Borup, J., West, R. E., & Thomas, R. (2015). *The impact of text versus video communication on instructor feedback in blended courses. Education Technology Research and Development*, 63, 161–184.
11. Bukowski, W. M., Buhrmester, D., & Underwood, M. K. (2011). *Peer relations as a developmental context*. In M. K. Underwood & L. H. Rosen (Eds.), *Social development* (pp. 153–179). New York, NY: Guilford
12. Burgess, S., & Sievertsen, H. H. (2020). *Schools, Skills, and Learning: The Impact of COVID-19 on Education*. <https://voxeu.org/article/impact-covid-19-education>
13. Carbonell, G. L., Banggawan M. L., & Agbisit, I. (2013). *Parent's role in enhancing the academic performance of students in the study of mathematics in Tabuk City, Philippines. International Journal of Advanced Research in Management and Social Sciences*, 2(8), 2278-6236.
14. Cheng, P., Xia, G., Pang, P., Wu, B., Jiang, W., Li, Y.-T., Wang, M., Ling, Q., Chang, X., Wang, J., Dai, X., Lin, X., Bi, X. (2020). *COVID-19 epidemic peer support and crisis intervention via social media. Community Mental Health Journal*, 56(5), 786–792. <https://doi.org/10.1007/s10597-020-00624-5>
15. Cobham, V. E., McDermott, B., Haslam, D., & Sanders, M. R. (2016). *The role of parents, parenting and the family environment in children's post-disaster mental health. Current Psychiatry Reports*, 18(6). <https://doi.org/10.1007/s11920-016-0691-4>
16. Daelo, E. (2010). *Perceived Effects of Parents Disciplinary Actions on the Academic Performance of Grade Vi Pupils in Barra Elementary School, A.Y. 2009-2010*. Lucban, Quezon: Southern Luzon State University.
17. Endendijk, J. J., Groeneveld, M. G., Bakermans-Kranenburg, M. J., & Mesman, J. (2016). *Gender-differentiated parenting revisited: Meta-analysis reveals very few differences in parental control of boys and girls. PLoS ONE*, 11(7), 1–33
18. Flannery, M. E. (2014, October 28). *All in the family: How teacher home visits can lead to school transformation*. Retrieved from <http://neatoday.org/2014/10/28/all-in-the-family-how-teacher-home-visits-can-lead-to-school-transformation/>
19. Froiland, J. M. (2015). *Parents' weekly descriptions of autonomy supportive communication: Promoting children's motivation to learn and positive emotions. Journal of Child and Family Studies*, 24, 117–126.
20. Griffith, A. K. (2020). *Parental burnout and child maltreatment during the COVID-19 pandemic. Journal of Family Violence*. <https://doi.org/10.1007/s10896-020-00172-2>
21. Gross (2015) "Relationship of perceived parenting style, locus of control orientation and self-concept Among junior high age students". From [http://dspace.library.colostate.edu/webclient/DeliveryManager/digitool\\_items/csu01\\_storage/2014/09/09file\\_1/333763](http://dspace.library.colostate.edu/webclient/DeliveryManager/digitool_items/csu01_storage/2014/09/09file_1/333763)
22. Henderson Lora, J., Williams, Joanna, L., and Bradshaw, Catherine, P., (2020). *Examining home-school dissonance as a barrier to parental involvement in middle school*.
23. Higgins, Aria Zhalet (2011) "Psychological Effects on Academic Performance". Online Thesis and Dissertation Paper 21. <http://encompass.eku.edu/etd/21>
24. *Hitting the streets for home visits. Leadership*, 39(2), 24-26. *The Effects of Teachers Home Visits on Student Behavior, Student Academic Achievement, and Parent Involvement* Kim Wright, Samantha M. Shields, Katie Black, and Hersh C. Waxman
25. Hornby, Garry (2011). *Parental Involvement in Childhood Education*. Springer Verlag, New York
26. Huang, J., Nigatu, Y. T., Smail-Crevier, R., Zhang, X., Wang, J. (2018). *Interventions for common mental health problems among university and college students: A systematic review and meta-analysis of randomized controlled trials. Journal of Psychiatric Research*, 107, 1–10. <https://doi.org/10.1016/j.jpsychires.2018.09.018>
27. Ilhan, F. Ozfidan, Yilmaz S., *Home visit effectiveness on students' classroom behavior and academic achievement* (2019). *Journal of Social Studies Education*.
28. Kazerooni, A., Amini, M., Tabari, P., Moosavi, M. (2020). *Peer mentoring for medical students during the COVID-19 pandemic via a social media platform. Medical Education*, 54(8), 762–763. <https://doi.org/10.1111/medu.14206>
29. Khan, R., Bushra Iqbal Chohan, (2011), *Impact of Parental Support on the Academic Performance and Self Concept of the Student*.
30. Lanciano Tiziana, Curci Antonietta. *The Incremental Validity of Emotional Intelligence ability in Predicting Academic Achievement*. <https://doi.org/10.5406/amerjpsyc.127.4.0447>
31. Landa, JMA, E. Lopez-Zafra, (2010). *The impact of emotional intelligence on nursing: An overview*. doi:10.4236/psych.2010.1008
32. Lin, M., & Bates, A. B. (2010). *Home visits: How do they affect teachers' beliefs about teaching and diversity? Early Childhood Education Journal*, 38(3), 179–185 <https://doi.org/10.1007/s10643-010-0393-1>





33. Liu, Cindy H., Amaker Stephanie Pinder, Hyeouk, Chris Ham, Chen, Justin (2020). *Priorities for addressing the impact of the Covid-19 Pandemic on college student mental health*. <https://doi.org/10.1080/07448481.2020.1803882>
34. Lucas, M. A. (2017). *Bridging the gap between schools and families through teacher home visits (Unpublished doctoral dissertation)*. Lindenwood University, St. Charles, Missouri. Retrieved from <https://search.proquest.com/openview/f391f0fd0584e52a816caeb63f1e2e26/1?pqorigsite=gscholar&cbl=18750&diss=y>
35. Meyer, J. A., & Mann, M. B. (2011). *Teachers' perceptions of the benefits of home visits for early elementary children*. *Early Childhood Education Journal*, 34(1), 93–97.
36. Minn, C. & Hau, I. (2020, May 20). *The next pandemic: Mental health*. *The EdSurge*, <https://www.edsurge.com/news/2020-05-30thenextpandemic-mental-health>.
37. Nyarko (2011) *The Influence of Authoritative Parenting Style on Adolescents Academic Achievement*.
38. *OHCHR/DECLARATION ON THE RIGHT OF THE CHILD (1959)* [https://www.ohchr.org/EN/Issues/Education/Training/Compilation/Pages/1DeclarationoftheRightsOfTheChild\(1959\).aspx](https://www.ohchr.org/EN/Issues/Education/Training/Compilation/Pages/1DeclarationoftheRightsOfTheChild(1959).aspx)
39. Orben, A., Tomova, L., Blakemore, S.-J. (2020). *The effects of social deprivation on adolescent development and mental health*. *The Lancet Child and Adolescent Health* 4(8), 634–640.
40. Pajariato, H., Abdul Kadir, Nursaqinah Galugu, Puspa Sari, Sofia Februanti (2020), *Study from Home in the Middle of the COVID-19 Pandemic: Analysis of Religiosity, Teacher, and Parents*.
41. *Philippine Copyright 2005, Chanrobles Publishing Company*
42. *Premier Value Provider Inc as cited in one news ph (2020) Stress, Anxiety, Depression on the Rise Among Gen Z, Millennial Employees and Those Working from Home (Survey)*.
43. Rafiq, et. al., (2013). *Parental Involvement and Academic Achievement; A Study on Secondary School Students of Lahore, Pakistan*. *International Journal of Humanities and social Science*. Bolume 3 No.8 Special Issue- April 2013.
44. Rosales, Sj. (2014). *Parenting Style and Its Development of Social Competence Among Grade III Pupils, A.Y. 2013-2014*. Lucban, Quezon: Southern Luzon State University.
45. Ruholt, Jonathan, S., and Dukes, Kristina (2015). *Is Parental Support or Parental Involvement More Important for Adolescents?*
46. Soto, J. et al. (2015). *Personality Traits in Childhood and Adolescence: Structure, Development, and Outcomes*. <https://doi.org/10.1177/0963721415589345>
47. Smith, Krishna (2011). *The Impact of Parental Involvement on Student Achievement*. ProQuest LLC. United States.
48. *St. Paul Federation of Teachers. (2014). Parent/teacher home visiting. Project evaluation. Retrieved from www.spft.org/wp-content/uploads/2013/08/spft-report-071014.pdf*
49. Teruel, David Sánchez, María Auxiliadora Robles-Bello, Nieves Valencia Naranjo (2020), *Do psychological strengths protect college students confined by COVID-19 to emotional distress? The role of gender*. <https://doi.org/10.1016/j.paid.2020.110507>
50. Thompson, R. A. (2012). *Whither the preconventional child? Toward a life-span moral development theory*. *Child Development Perspectives*, 6, 423–429.
51. Untevero, Aivie R. *“Parental Involvement in Academic Performance of Selected Bachelor of Science in Nursing Level IV Students in SLSU. “Unpublished Thesis, College of Teacher Educational Lucban, Quezon. (2013)*.
52. Wilk, P. et al., (2018) *Exploring the Effect of Parental Influence on Children's Physical Activity. The Mediating Role of Children's Perceptions of Parental Support*. <https://doi.org/10.1016/j.jpmed.2017.10.018>.
53. Wright, Kim, B., Shields, Samantha, M., Black, Katie, and Waxman, Hersh, C., (2018). *The Effects of Teacher Home Visits on Student Behavior, Student Academic Achievement, and Parent Involvement*
54. Zhai, Y. and Xue D. (2020) *Addressing collegiate mental health amid Covid-19 pandemic* <https://dx.doi.org/10.1016%2Fj.psychres.2020.113003>





## A REVIEW ON *TRIGONELLA FOENUM-GRAECUM* ACCORDING TO TRADITIONAL SYSTEMS OF MEDICINE

MMM.Nifras<sup>1\*</sup>, JF.Fatheena<sup>1</sup>, AM.Muthalib<sup>1</sup>

<sup>1</sup>Demonstrator, Institute of Indigenous Medicine, University of Colombo, Sri Lanka

<sup>1</sup>Demonstrator, Institute of Indigenous Medicine, University of Colombo, Sri Lanka

<sup>1</sup>Senior Lecturer, Institute of Indigenous Medicine, University of Colombo, Sri Lanka

### ABSTRACT

*Fenugreek (Trigonella foenum-graecum L.) is an erect annual herb which belongs to the family Fabaceae/Leguminosae. It is cultivated as leafy vegetable, condiment and as a medicinal plant. The fresh tender leaves and stem are consumed as curried vegetables and the seeds are used as spices for flavouring almost all the dishes. It is an old medicinal plant which has been commonly used in traditional systems of medicine. This study was carried out to give an overview on Fenugreek according to traditional systems of medicine and to review the recent scientific evidences of phytochemical and pharmacological studies systematically. Phytochemical evidences suggest major constituents found in Fenugreek are alkaloids, flavonoids, steroids, saponins etc. Fenugreek contains a number of steroidal saponins, specially diosgenin found in oily embryo. Two furastanol glycosides, F-ring opened precursors of diosgenin have been reported, as also hederagin glycosides. the alkaloid trigonelline, trigocoumarin, trimethyl coumarin and nicotinic acid are also present. From the seeds, mucilage as a prominent constituent, along with vitexin and isovitexin have been isolated. The stem contains diosgenin and trigoforin. Saponins isolated from leaves. Disogenin, gitogenin and tigogenin isolated from seeds. Pharmacological evidences suggest Fenugreek possesses pharmacological activities such as Anti diabetic, Anti-dyslipidemic activity, Immunomodulatory effect, Anti-oxidant activity, Anti-inflammatory activity and Anti-cancer activity.*

**KEY WORDS:** Fenugreek, Methi, Hulba, Methika, Venthayam

### INTRODUCTION

A spice is a dried seed, fruit, root, bark or flower of a plant or a herb used in small quantities for flavor, color or as a preservative. The spices and Herbs used for flavor, aroma and medicinal properties derive a special value from the said factors.<sup>1</sup> Spices and herbs have been in use for centuries both for culinary and medicinal purposes. Spices not only enhance the flavor, aroma, and color of food and beverages, but they can also protect from acute and chronic diseases. Long before modern medicine, spices were valued for their ability to help individuals in disease prevention and health promotion.<sup>2</sup>

Fenugreek (*Trigonella foenum-graecum* L.) is an erect annual herb which belongs to the family Fabaceae/ Leguminosae. It is cultivated as leafy vegetable, condiment and as a medicinal plant. The fresh tender leaves and stem are consumed as curried vegetables and the seeds are used as spices for flavouring almost all the dishes.<sup>3</sup> It is an old medicinal plant which has been commonly used in

traditional systems of medicine for therapeutic purposes.

### OBJECTIVE

1. To review the literature on 'Fenugreek'
2. To review the recent scientific evidences of phytochemical and pharmacological studies of Fenugreek systematically.

### METHODOLOGY

A systematic literature search was carried out to review articles and to gather the information available in the literature regarding Fenugreek in the view of description of the plant, chemical constituents, part used, therapeutic action and therapeutic uses, and recent scientific evidences of phytochemical and pharmacological activities. All the available information on Fenugreek was compiled from Unani, Ayurveda and Siddha textbooks & Pharmacopoeias and electronic databases such as Google scholar and PubMed.



## RESULTS

### Scientific Classification of Fenugreek<sup>4</sup>

Kingdom: Plantae  
 Super division: Angiosperms  
 Division: Eudicots  
 Class: Rosids  
 Order: Fabales  
 Family: Fabaceae  
 Genus: *Trigonella*  
 Species: *Foenum*

### Vernacular names<sup>5,6</sup>

English: Fenugreek  
 Tamil: Venthayam  
 Sinhala: Uluhal  
 Unani Tibbi name: Methi/ Hulba  
 Sanskrit name: Methika

### Description of the plant<sup>6</sup>

An erect annual herb,  
 Leaves: pinnate, 3 foliate, leaflet toothed;  
 Flowers: pale yellow or white, 1 or 2 axillaries; calyx lobes subulate;

Pods: 5-8cm long, with a long persistent beak, 10-20 seeded;

Seeds: greenish brown, oblong with a deep groove across one corner, giving the seeds a hooked appearance.

**Parts used:** Seeds<sup>6</sup>

### CHEMICAL CONSTITUENTS

Fenugreek contains a number of steroidal sapogenins, specially diosgenin found in oily embryo. Two furastanol glycosides, F-ring opened precursors of diosgenin have been reported, as also hederagin glycosides. the alkaloid trigonelline, trigocoumarin, trimethyl coumarin and nicotinic acid are also present. From the seeds, mucilage as a prominent constituent, along with vitexin and isovitexin have been isolated. The stem contains diosgenin and trigoforin. Saponins isolated from leaves. Disogenin, gitogenin and tigogenin isolated from seeds.<sup>5</sup>

Trigonelline, a major alkaloid component of fenugreek, is reported to be responsible for most of its pharmacological activities.<sup>7</sup>

### PROPERTIES OF FENUGREEK ACCORDING TO UNANI, AYURVEDA AND SIDDHA SYSTEMS OF MEDICINE

Table 01 shows the properties of the Fenugreek according to the traditional systems of medicine.

Table 01: Properties of Fenugreek according to Unani, Ayurveda and Siddha systems of medicine

Unani <sup>6</sup>	Ayurveda <sup>5,8</sup>	Siddha <sup>9</sup>
<b>Taste:</b> Sharp bitter <b>Mizaj (Temperament):</b> Hot 2 <sup>0</sup> and Dry 2 <sup>0</sup>  <b>Naf 'e Khas (Actions):</b> Mulattif (Demulcent) Mudir-e-Baul (Diuretic) Mudir-e-Haiz (Emmenagogue) Mulaiyyin (Laxative) Munaffis-e-Balgham (Expectorant) Muhallil-e-Waram (Anti-inflammatory)	<b>Rasa (taste):</b> Tikta (Bitter) <b>Vipaka (post digestive effect):</b> Katu (Pungent) <b>Virya (potency):</b> Usna (Hot) <b>Guna (attributes):</b> Snigdha (Unctous) <b>Karma:</b> Deepana Kaphahara Rucya Vatahara	<b>Cuvai:</b> Kaippu <b>Gunam:</b> Noymai <b>Virium:</b> Tadpam <b>Pirivu:</b> Kaarppu  <b>Ceykai:</b> Akadduvayvakatri, Ciruneerperukki, Kaamamperukki, Thuvarppi, Ullazhaatri, Uramaakki, Varadchiyakatri

### THERAPEUTIC USES OF FENUGREEK ACCORDING TO UNANI, AYURVEDA AND SIDDHA SYSTEMS OF MEDICINE

Table 02 shows the Therapeutic uses of Fenugreek according to the traditional systems of medicine.

Table 02: Therapeutic uses of Fenugreek according to Unani, Ayurveda and Siddha systems of medicine

Unani <sup>6</sup>	Ayurveda <sup>8</sup>	Siddha <sup>9</sup>
<ul style="list-style-type: none"> <li>Sara (Epilepsy)</li> <li>Niqras (Gout)</li> <li>Istisqa-e-Ziqqi (Dropsy)</li> <li>Sual Muzmin (Chronic cough)</li> <li>Izm-e-Tihal-o-Kabid (Enlargement of Spleen and Liver)</li> <li>Waram-e-Rahem (Uteritis)</li> </ul>	<ul style="list-style-type: none"> <li>Aruci (Tastelessness)</li> <li>Grahani (Malabsorption syndrome)</li> <li>Jvara (Fever)</li> <li>Prameha (Increased frequency turbidity of urine)</li> </ul>	<ul style="list-style-type: none"> <li>Ilaippu Noy</li> <li>Ceethakkazhichchal</li> <li>Kuruthi Azhal</li> <li>Neerizhivu</li> <li>Neervedkai</li> <li>Udal Erichal</li> <li>Vellai</li> </ul>



### COMPOUND FORMULATIONS OF FENUGREEK ACCORDING TO UNANI, AYURVEDA AND SIDDHA SYSTEMS OF MEDICINE

Table 03 shows the Compound formulations of Fenugreek according to the traditional systems of medicine.

Table 03: Compound formulations of Fenugreek according to Unani, Ayurveda and Siddha systems of medicine

Unani <sup>6</sup>	Ayurveda <sup>5,8</sup>	Siddha <sup>9</sup>
<ul style="list-style-type: none"> <li>Habb-e-Khabsul Hadeed</li> <li>Qairuti Arad Krasna</li> <li>Laoq Habb-ul-Sanobar</li> <li>Marham-e-Dakhliyun</li> </ul>	<ul style="list-style-type: none"> <li>Methika Modaka</li> <li>Methika Paaka</li> <li>Methika Seed Powder</li> <li>Mustakaarista</li> <li>Mrtasanjeevaneer Suraa</li> </ul>	<ul style="list-style-type: none"> <li>Cunavatrul Choornam</li> <li>Kanattailam</li> <li>Kapaada Maaththirai</li> <li>Korocanaitthuhul</li> </ul>

### DOSAGE OF FENUGREEK ACCORDING TO UNANI, AYURVEDA AND SIDDHA SYSTEMS OF MEDICINE

Table 04 shows the Dosage of Fenugreek according to the traditional systems of medicine.

Table 04: Dosage of Fenugreek according to Unani, Ayurveda and Siddha systems of medicine

Unani <sup>6</sup>	Ayurveda <sup>8</sup>	Siddha <sup>9</sup>
4-6g	3-6g (Powder)	3-6g (Powder)

### RECENT SCIENTIFIC EVIDENCES

#### Pharmacological activities of Fenugreek

Following table shows the recent evidences of pharmacological activities of Fenugreek.

Table 05: Pharmacological activities of Fenugreek

Pharmacological activity	References
Anti-diabetic activity <sup>10,11,7,12,13,14,15,16</sup>	Najdi RA, et al. (2019) Geberemeskel GA, et al. (2019) Subramanian SP, et al. (2014) Haeri MR, et al. (2012) Moorthy R, et al. (2010) Xue WL, et al. (2007) Puri D, et al. (2002) Zia T, et al. (2001)
Anti-dyslipidemic activity <sup>14,17,7,18</sup>	Xue WL, et al. (2007) Chen Z, et al. (2017) Subramanian SP, et al. (2014) Upma C, et al. (2013)
Immunomodulatory effect <sup>19</sup>	Hafeez BB, et al. (2003)
Anti-oxidant activity <sup>20,18,21</sup>	Tewari D, et al. (2020) Upma C, et al. (2013) Kaviarasan S, et al. (2007)
Anti-inflammatory activity <sup>22</sup>	Ahmadiani A, et al. (2001)
Anti-cancer activity <sup>23</sup>	El Bairi K, et al. (2017)

### CONCLUSION

Fenugreek is traditionally consumed as a medicinal plant since prehistoric time and is undoubtedly considered safe to human health. Its nutritional value and biologically active compound profile are unquestionably appreciated by medical science. Fenugreek is rich in fiber, protein and due to its valuable bioactive components, such as alkaloids, flavonoids, steroids, saponins it shows promising therapeutic effects. Anti-diabetic, Anti-dyslipidemic activity, Immunomodulatory effect, Anti-oxidant activity, Anti-inflammatory activity and Anti-cancer activity are the major medicinal properties of the fenugreek. The liberal consumption

of the fenugreek seeds is proved to be safe, and provide health beneficial effects through its rich fiber content and other bioactive components. In view of the therapeutic effects, it is considered as a natural and necessary ingredient of our daily diet.

### REFERENCES

- Sachan AKR, Kumar S, Kumari K, Singh D. Medicinal uses of spices used in our traditional culture: World Wide. *Journal of Medicinal Plants Studies* 2018; 6(3): 116-122
- Jiang TA. Health Benefits of Culinary Herbs and Spices. *J AOAC Int.* 2019 Mar 1;102(2):395-411.
- Kumar N, Khader A, Rangaswami P, Irulappan I. (1997). *Introduction to Spices, Plantation crops,*



- Medicinal and Aromatic plants. Oxford and IBH publishing, New Delhi.*
- Nathiya S, Durga M, Devasena T. Therapeutic role of *Trigonella foenum-graecum* [Fenugreek] - A Review. *Int. J. Pharm. Sci. Rev. Res.*, 27(2), July – August 2014; Article No. 12, Pages: 74-80
  - Paranjpe P. (2001). *Indian Medicinal Plants, Forgotten Healers, A Guide to Ayurvedic Herbal Medicine. Chaukhamba Sanskrit Pratishthan, Delhi.*
  - Standardization of Single Drugs of Unani Medicine. (Part I). Central Council for Research in Unani Medicine. Ministry of Health and Family Welfare Govt.of India, New Delhi.
  - Subramanian SP, Prasath GS. Antidiabetic and antidyslipidemic nature of trigonelline, a major alkaloid of fenugreek seeds studied in high-fat-fed and low-dose streptozotocin-induced experimental diabetic rats, *Biomedicine & Preventive Nutrition*, Volume 4, Issue 4, 2014, Pages 475-480.
  - The Ayurvedic Pharmacopoeia of India. PART – I, VOLUME – II. Government of India Ministry of Health and Family Welfare Department of Ayush.*
  - The Siddha Pharmacopoeia of India. Part – I, Volume – I. Government of India Ministry of Health and Family Welfare Department of Ayurveda, Yoga & Naturopathy, Unani, Siddha and Homoeopathy (Ayush).*
  - Najdi RA, Hagraas MM, Kamel FO, Magadmi RM. A randomized controlled clinical trial evaluating the effect of *Trigonella foenum-graecum* (fenugreek) versus glibenclamide in patients with diabetes. *Afr Health Sci.* 2019 Mar;19(1):1594-1601.
  - Geberemeskel GA, Debebe YG, Nguse NA. Antidiabetic Effect of Fenugreek Seed Powder Solution (*Trigonella foenum-graecum* L.) on Hyperlipidemia in Diabetic Patients. *J Diabetes Res.* 2019 Sep 5;2019:8507453.
  - Haeri MR, Limaki HK, Christopher J. White B, White KN. Non-insulin dependent anti-diabetic activity of (2S, 3R, 4S) 4-hydroxyisoleucine of fenugreek (*Trigonella foenum graecum*) in streptozotocin-induced type I diabetic rats, *Phytomedicine*, Volume 19, Issue 7, 2012, Pages 571-574.
  - Moorthy R, Prabhu KM, Murthy PS. Anti-hyperglycemic compound (GII) from fenugreek (*Trigonella foenum-graecum* Linn.) seeds, its purification and effect in diabetes mellitus. *Indian J Exp Biol.* 2010 Nov;48(11):1111-8.
  - Xue WL, Li XS, Zhang J, Liu YH, Wang ZL, Zhang RJ. Effect of *Trigonella foenum-graecum* (fenugreek) extract on blood glucose, blood lipid and hemorheological properties in streptozotocin-induced diabetic rats. *Asia Pac J Clin Nutr.* 2007;16 Suppl 1:422-6.
  - Puri D, Prabhu KM, Murthy PS. Mechanism of action of a hypoglycemic principle isolated from fenugreek seeds. *Indian J Physiol Pharmacol.* 2002 Oct;46(4):457-62.
  - Zia T, Hasnain SN, Hasan SK. Evaluation of the oral hypoglycaemic effect of *Trigonella foenum-graecum* L. (methi) in normal mice, *Journal of Ethnopharmacology*, Volume 75, Issues 2–3, 2001, Pages 191-195.
  - Chen Z, Lei YL, Wang WP, Lei YY, Liu YH, Hei J, Hu J, Sui H. Effects of Saponin from *Trigonella Foenum-Graecum* Seeds on Dyslipidemia. *Iran J Med Sci.* 2017 Nov;42(6):577-585.
  - Upma C, Atul S, Smriti B, Jitendra KS, Gitika B. A Mechanism-based Pharmacological Evaluation of Efficacy of *Trigonella foenum graecum* (Fenugreek) Seeds in Regulation of Dyslipidemia and Oxidative Stress in Hyperlipidemic Rats, *Journal of Cardiovascular Pharmacology: June 2013 - Volume 61 - Issue 6 - p 505-512*
  - Hafeez BB, Haque R, Parvez S, Pandey S, Sayeed I, Raisuddin S. Immunomodulatory effects of fenugreek (*Trigonella foenum graecum* L.) extract in mice, *International Immunopharmacology*, Volume 3, Issue 2, 2003, Pages 257-265.
  - Tewari D, Józwiak A, Łysek-Gładysińska M, Grzybek W, Adamus-Białek W, Bicki J, Strzałkowska N, Kamińska A, Horbańczuk OK, Atanasov AG. Fenugreek (*Trigonella foenum-graecum* L.) Seeds Dietary Supplementation Regulates Liver Antioxidant Defense Systems in Aging Mice. *Nutrients.* 2020 Aug 24;12(9):2552.
  - Kaviarasan S, Naik GH, Gangabhairathi R, Anuradha CV, Priyadarsini KI. In vitro studies on antiradical and antioxidant activities of fenugreek (*Trigonella foenum graecum*) seeds, *Food Chemistry*, Volume 103, Issue 1, 2007, Pages 31-37.
  - Ahmadiani A, Javan M, Semnianian S, Barat E, Kamalinejad M. Anti-inflammatory and antipyretic effects of *Trigonella foenum-graecum* leaves extract in the rat, *Journal of Ethnopharmacology*, Volume 75, Issues 2–3, 2001, Pages 283-286.
  - El Bairi K, Ouzir M, Agnieszka N, Khalki L. Anticancer potential of *Trigonella foenum graecum*: Cellular and molecular targets. *Biomed Pharmacother.* 2017 Jun;90:479-491.



# DETECTING DIFFERENTIAL ITEM FUNCTIONING IN 2019 BECE BASIC SCIENCE MULTIPLE CHOICE ITEMS ADMINISTERED IN SCHOOLS IN RIVERS STATE, NIGERIA

**Dr. Wokoma T. Abbott.**

*Government Technical College, Port Harcourt, Rivers State, Nigeria*

Article DOI: <https://doi.org/10.36713/epra7431>  
DOI No: 10.36713/epra7431

## ABSTRACT

*The study investigated items of 2019 basic science multiple choice, basic education certificate examination (BECE), conducted by the Rivers state ministry of education for junior secondary school three certification. The study attempted to detect differential item functioning of the administered items on urban and rural JSS3 students in Rivers State. A sample size of 240 students drawn from the entire JSS3 population in the state using multistage random sampling technique were used for the study; 120 from urban and 120 from rural schools. Comparative research design was adopted as the framework in this study. The 60 multiple choice 2019 basic science BECE items were used as instrument for data collection which were administered to the students. Items were dichotomously scored. R software was used for item analysis to determine difficulty and discrimination parameters in Two Parameter Logistic Model (2PLM) of Item Response Theory (IRT). R was also adopted to detect differentially functioning items using Mantel-Haenszel DIF detection method. The study compared results between urban and rural students item characteristic curves, parameters, chi-square statistics, and p-values. It was discovered that urban students found more of the 2019 basic science BECE items easier than their counterparts in the rural areas. The study also revealed that some items differentially functioned between the two groups when used to assess them. Based on the findings, it was recommended that basic science items for such assessment should be thoroughly checked for DIF, and if found, eliminated or edited before use. Both urban and rural students should be placed on the same condition of learning.*

**KEYWORDS:** *Item Response Theory, Differential Item Functioning*

## INTRODUCTION

Students in junior secondary schools are given certification examination at the end of their three years academic programme. This examination, known as Basic Education Certificate Examination (BECE) or Junior School Certificate Examination (JSCE), is conducted by the Rivers State Ministry of Education for all junior secondary school three (JSS3) students in public and private schools in Rivers state. This examination is in accordance with the 6-3-3-4 education policy in Nigeria.

The Rivers State Ministry of Education (MOE) assess students on the basic education subjects and certify them to proceed to the next level (Senior Secondary School). The certification is based on the number of credit passes obtained. Students are expected to pass six subjects including English language, mathematics, basic science, business studies, etc. This criterion is set as the standard to evaluate all students from the different regions (rural, semi-urban and urban), socioeconomic disposition of parents/guardians, teaching strength and aids available in schools. The BECE being conducted on only the cognitive domain also calls for concern.

The BECE is a high stake and a large scale test. The items used in all the subjects should have stable psychometric dimensions. Items parameters such as difficulty discrimination and guessing indices should remain constant during assessment of both rural, semi-rural and urban subgroups of students. Change in these items characteristics during assessment is referred to as differential item functioning (DIF). This change negate the invariance assumption of item response theory (IRT), which states that item parameter indices should remain the same for subgroups of the same population during assessment (Goldstain, 1983; Wollack, Sung & Kang; 2006; Li, 2008).





DIF (uniform and non-uniform) and item parameter drift (IPD) are almost similar concepts. Both are violations of the item parameter invariance assumption of IRT. DIF explains change in item characteristics when samples of the same population are measured repeatedly with the same instrument (Pine, 1977; Goldstein, 1983; Bock, Muraki & Pfeifferberger, 1988; Holland & Wainer, 1993; Wollack, Sung & Kang; 2006). IPD explains the change in item parameter indices at different times or occasions of testing individuals of the same ability on a task. This difference can lead to lowering of reliability and validity of tests, as well as biases in person and parameter estimation (Babcock & Albano, 2011; Bulut, Stanke, Rodriguez, Palma Vue, & Cabrera, 2013).

All students progressing from JSS1 through JSS3 are bound to pass through differing emotional, physical and socioeconomic experiences in and outside the classrooms, which in turn may modify their character. Strength and styles of instruction adopted for teaching and learning in the different school settings, the types and number of teaching aids available in the various schools, and the level of supervision of learning activities are not the same in the schools across the state. These may lead to different experiences in students of the same level.

The plethora of differences in the learners, learning methods, environmental and social dispositions were the factors that aroused the researcher's interest. This study empirically investigated the number of items present in 2019 basic science objective items that exhibited difference in difficulty and discrimination parameters.

In the course of this study, the researcher intended to ascertain the presence of DIF items in the 2019 basic science BECE conducted by ministry of education in Rivers State. The following research questions and hypothesis were formed to guide this study.

### RESEARCH QUESTIONS.

1. To what extent do items of 2019 basic science BECE differ in difficulty indices during testing between rural and urban JSS3 students in Rivers State?
2. To what extent do items of 2019 basic science BECE differ in discrimination indices during testing between rural and urban JSS3 students in Rivers State?
3. How many items of 2019 basic science BECE are DIF items?

### HYPOTHESIS.

1. There are no DIF items of 2019 basic science BECE.

### METHODOLOGY

**Sample:** All the JSS3 students in both private and public schools formed the population of this study. A total of 12 schools were randomly selected for the study using stratified random sampling; six from urban and six from rural. A total of 20 students were also randomly selected from each of the 12 schools. So, the total number of the students used for this study was 240; 120 from rural schools and 120 from urban schools.

### Instrument for Data Collection

The 2019 Rivers State MOE BECE Basic Science objective (section A) items were used for the study. This had 60 multiple choice items. These items were administered to JSS3 students in a normal classroom examination setting in their schools. Items were dichotomously scored (1 for correct and 0 for incorrect) thereafter.

### Analysis

After items were dichotomously scored, R software was used to determine difficulty (b) and discrimination (a) parameters. Two-parameter logistic model (2PLM) of IRT was adopted in the analysis and the associated packages were used in the item parameter analysis. This was because the packages provided a framework for IRT analyses for dichotomous data under a marginal Maximum Likelihood approach (Rizopoulos, 2006).

Difficulty and discrimination parameter analyses were carried out using on the dichotomously scored items using ltm package. Other R packages were also used to detect DIF in the items. Some methods of DIF detection are Transformed Item Difficulty (TID), Mantel-Haenzel, Standardization, Logistic regression, Breslow-ay, Lord Chi-square test and Raju's area methods. The item characteristic curve showed the plots of all the 60 items.

## RESULTS

*b* is Difficulty parameter, *a* is Discrimination parameter.

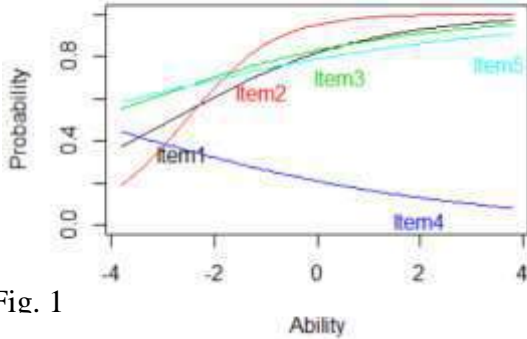


Fig. 1

	<i>b</i>	<i>a</i>
Item1	-2.8292	5.2503
Item2	-2.5526	1.1461
Item3	-4.3910	3.5774
Item4	-4.6183	-2.8665
Item5	-5.1213	2.5494

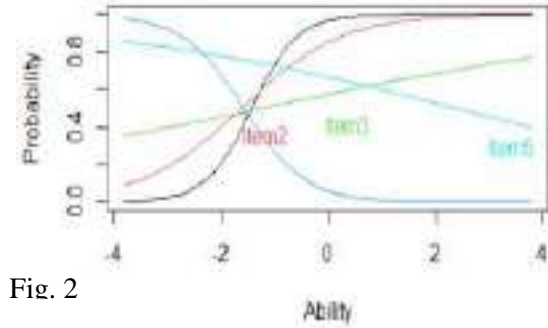


Fig. 2

	<i>b</i>	<i>a</i>
Item1	-1.4245	2.3428
Item2	-1.6206	1.0691
Item3	-1.2315	0.2408
Item4	-1.5736	-1.7327
Item5	2.3952	-0.2868

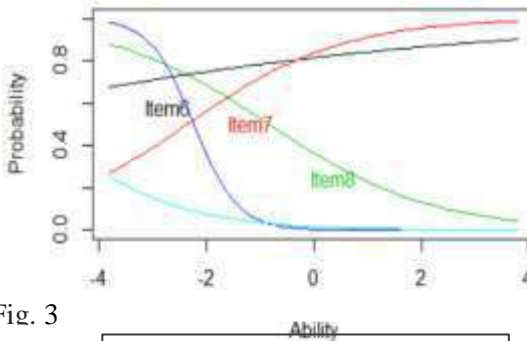


Fig. 3

	<i>b</i>	<i>a</i>
Item6	-7.6270	1.9287
Item7	-2.3460	6.9116
Item8	-8.2396	-6.6373
Item9	-2.2304	-2.4629
Item10	-5.1644	-7.8620

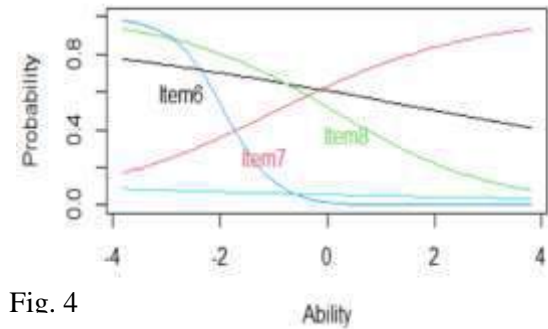


Fig. 4

	<i>b</i>	<i>a</i>
Item6	2.0669	-0.2112
Item7	-0.9459	0.5549
Item8	0.1339	-0.6674
Item9	-1.9204	-2.0946
Item10	-22.8480	-0.1229

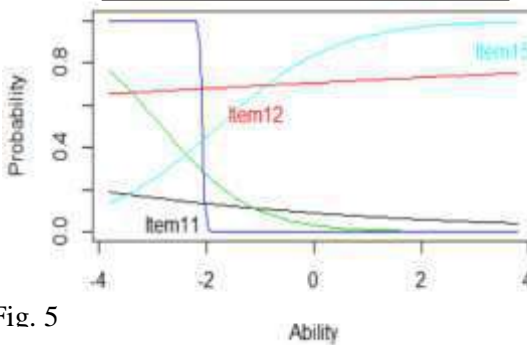


Fig. 5

	<i>b</i>	<i>a</i>
Item11	-1.0325	-2.2339
Item12	-1.3999	6.2154
Item13	-2.8330	-1.1906
Item14	-2.0715	-4.5074
Item15	-1.7689	9.0927

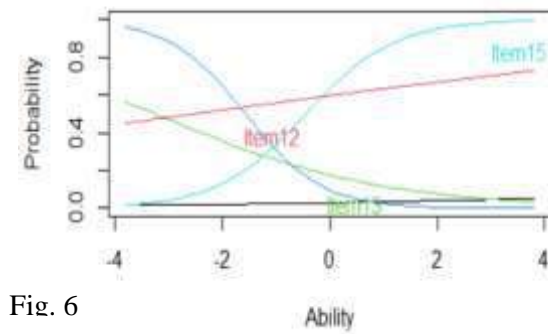


Fig. 6

	<i>b</i>	<i>a</i>
Item11	21.6440	0.1605
Item12	-2.5372	0.1557
Item13	-3.2333	-0.4735
Item14	-1.5625	-1.4140
Item15	-0.4408	1.2085

*b* is Difficulty parameter, *a* is Discrimination parameter

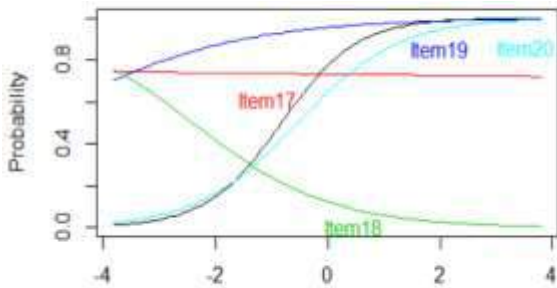


Fig. 7

	<i>b</i>	<i>a</i>
Item16	-8.2316	1.4901
Item17	6.5660	-1.5327
Item18	-2.4052	-8.1601
Item19	-5.2853	5.7887
Item20	-5.2983	1.1146

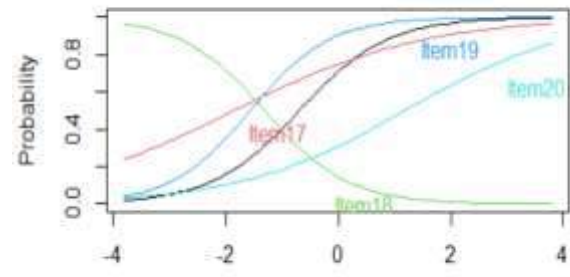


Fig. 8

	<i>b</i>	<i>a</i>
Item16	-0.6899	1.2747
Item17	-1.8500	0.5928
Item18	-1.3081	-1.3487
Item19	-1.5617	1.4157
Item20	1.1857	0.6810

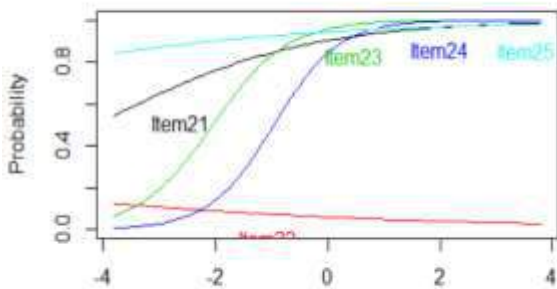


Fig. 9

	<i>b</i>	<i>a</i>
Item21	-4.1145	5.4023
Item22	-1.3041	-2.1029
Item23	-2.0468	1.5121
Item24	-9.5741	1.7398
Item25	-9.2620	3.0303

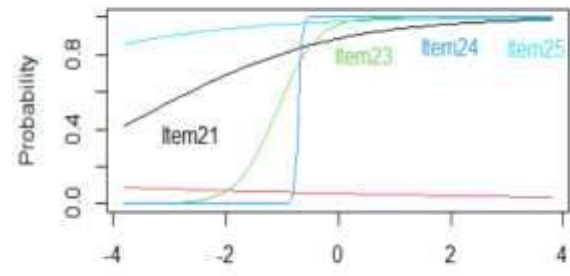


Fig. 10

	<i>b</i>	<i>a</i>
Item21	-3.2824	0.6214
Item22	-22.2117	-0.1265
Item23	-1.0885	2.8744
Item24	-0.7064	35.0288
Item25	-7.2176	0.5180

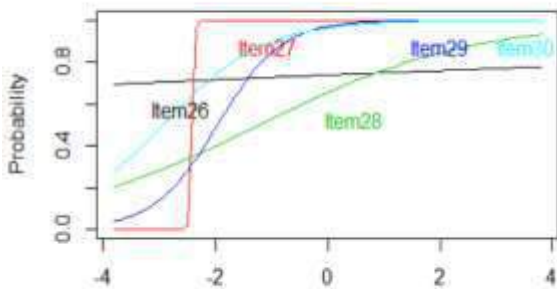


Fig. 11

	<i>b</i>	<i>a</i>
Item26	-1.8266	5.6520
Item27	-2.4127	4.6570
Item28	-1.2077	5.2233
Item29	-1.9610	1.7578
Item30	-2.9305	1.1127

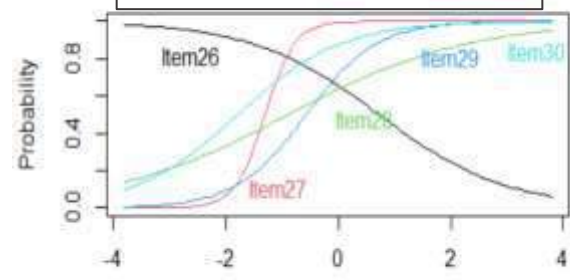


Fig. 12

	<i>b</i>	<i>a</i>
Item26	0.7290	-0.8807
Item27	-1.3012	3.7751
Item28	-0.8828	0.6274
Item29	-0.5663	1.5934
Item30	-1.7817	1.0895



*b* is Difficulty parameter, *a* is Discrimination parameter

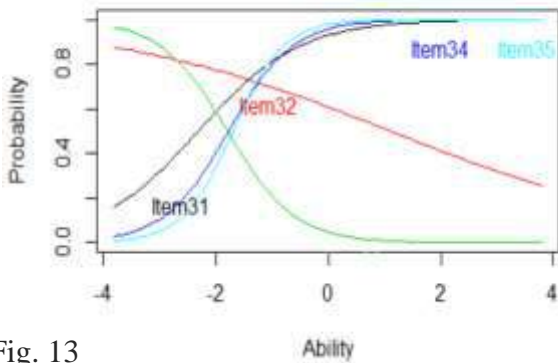


Fig. 13

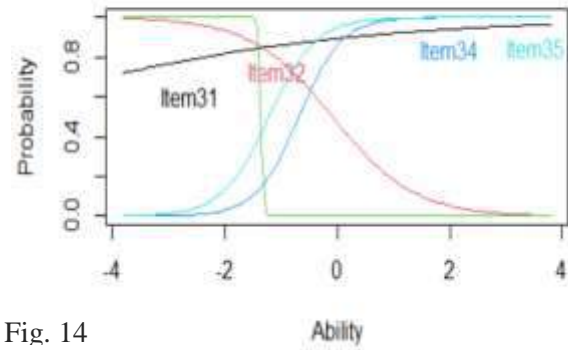


Fig. 14

	<i>b</i>	<i>a</i>
Item31.	-2.3086.	1.1081
Item32	1.1110	-3.9669
Item33	-1.7902	-1.6725
Item34	-1.7718	1.7462
Item35	-1.6915	2.2369

	<i>b</i>	<i>a</i>
Item31	-6.8226	0.3117
Item32	-0.0829	-1.3753
Item33	-1.3555	-52.1688
Item34	-0.6812	2.6304
Item35	-1.2114	2.3958

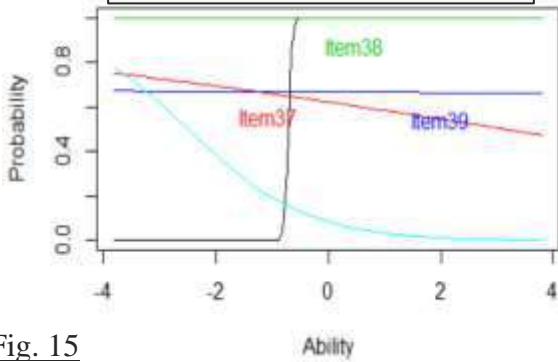


Fig. 15

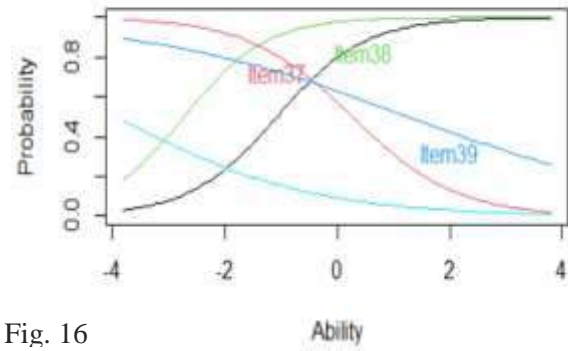


Fig. 16

	<i>b</i>	<i>a</i>
Item36	-7.0704	3.2328
Item37	3.1140	-1.5947
Item38	2.1567	-3.0402
Item39	1.2193	-5.6687
Item40	-2.4941	-9.4867

	<i>b</i>	<i>a</i>
Item36	-1.0695	1.2705
Item37	0.2732	-1.0810
Item38	-2.7213	1.3716
Item39	1.2850	-0.4159
Item40	-3.9216	-0.5811

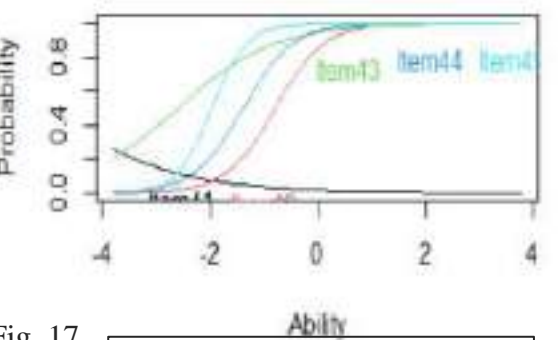


Fig. 17

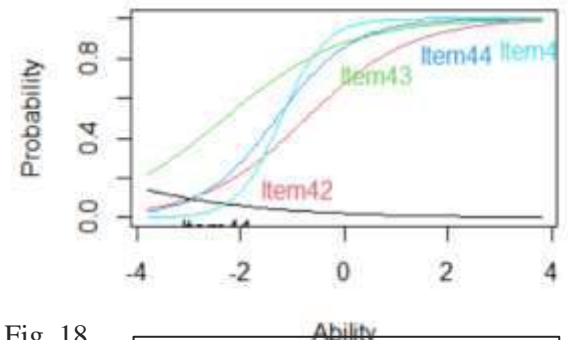


Fig. 18

	<i>b</i>	<i>a</i>
Item41	-5.1644	-7.8620
Item42	-7.9233	2.2169
Item43	-2.5939	1.1083
Item44	-1.3803	2.2009
Item45	-1.9543	3.0956

	<i>b</i>	<i>a</i>
Item41	-7.3555	-0.5074
Item42	-0.7301	0.9893
Item43	-2.3104	0.8529
Item44	-1.3009	1.3677
Item45	-1.2114	2.3950

*b* is Difficulty parameter, *a* is Discrimination parameter

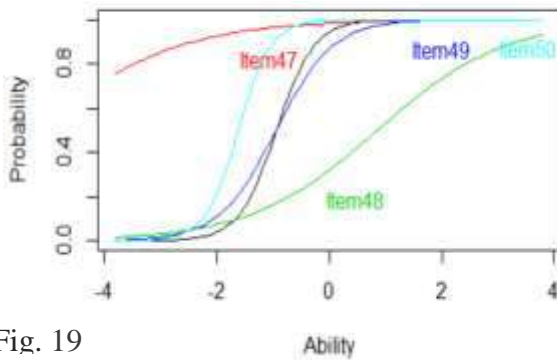


Fig. 19

	<i>b.</i>	<i>. a</i>
Item46	-9.3421	3.0031
Item47	-5.2662	7.6587
Item48	8.6065	8.8221
Item49	-9.4457	1.9828
Item50	-1.6190	3.4285

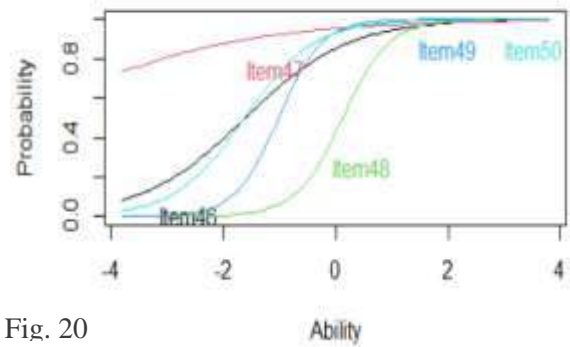


Fig. 20

	<i>b</i>	<i>a</i>
Item46	-1.6045	1.0893
Item47	-5.6947	0.5297
Item48	0.1242	2.4240
Item49	-1.0162	2.6003
Item50	-1.6232	1.6056

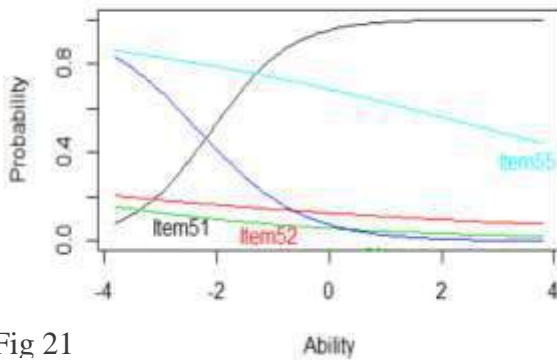


Fig 21

	<i>b</i>	<i>a</i>
Item51	-2.0889	1.4216
Item52	-1.2856	-1.5070
Item53	-9.5780	-2.9219
Item54	-2.3285	-1.0878
Item55	2.8992	-2.6797

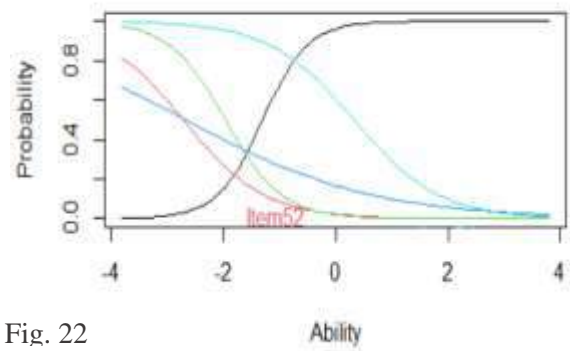


Fig. 22

	<i>b</i>	<i>a</i>
Item51	-1.3007	2.4752
Item52	-2.7127	-1.3785
Item53	-1.9646	-1.9884
Item54	-2.6665	-0.6007
Item55	0.3275	-1.3277

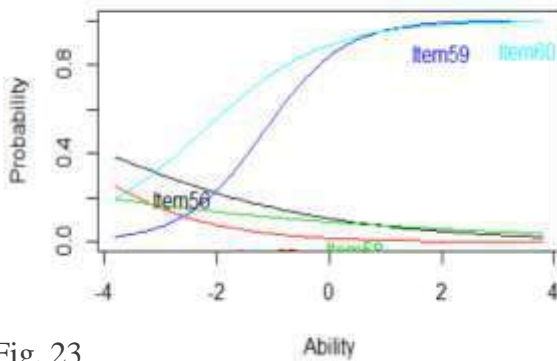


Fig. 23

	<i>b</i>	<i>a</i>
Item56	-4.8829	-4.3656
Item57	-5.1643	-7.8620
Item58	-9.9298	-2.3287
Item59	-1.1542	1.4130
Item60	-2.2465	9.2354

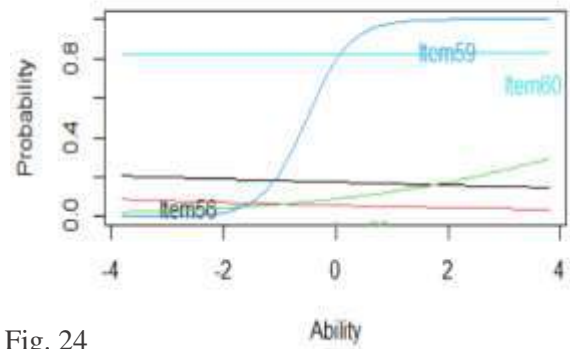


Fig. 24

	<i>b</i>	<i>a</i>
Item56	-28.6012	-0.0543
Item57	-22.8480	-0.1229
Item58	6.0938	0.3808
Item59	-0.5085	2.5870
Item60	-248.9673	0.0062





Mantel-Haenszel Chi-square statistic:

	<b>Stat.</b>	<b>P-value</b>
<b>Item1.</b>	0.2707	0.6029
<b>Item2.</b>	0.0208	0.8852
<b>Item3.</b>	2.9442	0.0862.
<b>Item4.</b>	0.2806	0.5963
<b>Item5.</b>	1.9895	0.1584
<b>Item7.</b>	0.0127	0.9101
<b>Item8.</b>	4.1932	0.0406 *
<b>Item9.</b>	0.0408	0.8399
<b>Item10</b>	0.1250	0.7237
<b>Item11</b>	0.0000	1.0000
<b>Item12</b>	4.0497	0.0442 *
<b>Item13</b>	0.2576	0.6118
<b>Item14</b>	3.7448	0.0530.
<b>Item15</b>	0.1184	0.7308
<b>Item16</b>	0.7339	0.3916
<b>Item17</b>	2.0518	0.1520
<b>Item18</b>	1.6456	0.1996
<b>Item19</b>	0.5901	0.4424
<b>Item20</b>	0.0667	0.7963
<b>Item21</b>	Inf	0.0000 ***
<b>Item22</b>	Inf	0.0000 ***
<b>Item23</b>	3.9750	0.0462 *
<b>Item24</b>	0.0068	0.9340
<b>Item25</b>	Inf	0.0000 ***
<b>Item26</b>	1.7410	0.1870
<b>Item27</b>	0.0000	1.0000
<b>Item28</b>	0.1557	0.6931
<b>Item29</b>	0.2361	0.6271
<b>Item30</b>	0.1889	0.6638
<b>Item31</b>	0.0781	0.7799
<b>Item32</b>	0.1565	0.6924
<b>Item33</b>	0.1468	0.7016
<b>Item34</b>	0.0006	0.9813
<b>Item35</b>	0.0310	0.8602
<b>Item36</b>	0.0244	0.8759
<b>Item37</b>	0.0086	0.9261
<b>Item38</b>	0.0208	0.8852
<b>Item39</b>	0.1815	0.6701
<b>Item40</b>	0.1167	0.7326
<b>Item41</b>	0.1250	0.7237
<b>Item42</b>	0.3889	0.5329
<b>Item43</b>	0.0009	0.9761
<b>Item44</b>	0.1142	0.7354
<b>Item45</b>	0.3125	0.5762
<b>Item46</b>	3.7902	0.0516
<b>Item47</b>	0.3452	0.5569
<b>Item48</b>	0.1565	0.6924
<b>Item49</b>	1.2380	0.2658
<b>Item50</b>	0.5901	0.4424
<b>Item51</b>	0.3333	0.5637
<b>Item52</b>	0.0408	0.8399
<b>Item53</b>	1.5610	0.2115
<b>Item54</b>	0.0669	0.7960
<b>Item55</b>	0.6403	0.4236
<b>Item56</b>	0.0669	0.7960



Item57	0.1250	0.7237
Item58	0.1250	0.7237
Item59	0.1789	0.6723
Item60	0.0984	0.7537

Significant. codes: 0 '\*\*\*' 0.001 '\*\*' 0.01 '\*' 0.05 '.' 0.1 ' ' 1

Detection threshold: 3.8415 (significance level: 0.05)

Items detected as DIF items:

Item8  
Item12  
Item21  
Item22  
Item23  
Item25

Looking at the pattern of the result, most of the items are very easy because their standard deviation fell below zero. Out of the 60 items only items 17, 32, 37, 38, 39, 48 and 55 (just about 11.67% of the total items) showed standard deviation of more than zero when administered on urban JSS 3 students. The pattern of result from the rural students examined also showed that 11 items (items 5, 6, 8, 11, 20, 26, 37, 39, 48, 55 and 58) have difficulty indices above zero out of the 60 item, representing about 18.33%. From this result the urban JSS3 students has better chance of passing when compared to their counterparts in the rural areas.

In comparison, 39 items (1, 2, 3, 4, 5, 6, 7, 8, 9, 11, 14, 15, 16, 18, 19, 20, 21, 23, 24, 25, 26, 27, 28, 29, 30, 33, 34, 35, 36, 39, 42, 43, 44, 45, 46, 49, 53, 58 and 59) were found to be easier for the urban JSS3 students while 21 items (10, 12, 13, 17, 22, 31, 32, 37, 38, 40, 44, 47, 48, 50, 51, 52, 54, 55, 56, 57, and 60) were also found to be easier for the rural subgroup.

Discrimination parameter is an index that shows how good an item is in classifying examinees either below or above the difficulty parameter of an item. Normally an index of 1.00 is ideal. Items having indices greater than 1.00 are better but less than 1.00 are not good discriminators. On separate administration of the instrument to both urban and rural JSS3 students and after analysis, varying discrimination indices were obtained ranging from negative to positive values. Out of the 60 items administered the urban students 28 items (4, 8, 9, 10, 11, 13, 14, 17, 22, 32, 33, 37, 38, 39, 40, 41, 52, 53, 54, 55, 56, 57 and 58) had negative discrimination indices while the rest had positive indices. After administering to the rural student it was also found that 23 items (4, 5, 6, 8, 9, 10, 13, 14, 18, 22, 26, 32, 33, 37, 39, 40, 41, 52, 53, 54, 55, 56 and 57) had negative discrimination indices.

## DISCUSSION

From the results of the analyses, both groups of students responded to the 2019 BECE basic science items. It was found that each of the items had differing difficulty indices as the two subgroup of students were measured. The results showed that rural students encountered more difficult items (11) than their urban counterparts who had only seven (7) items out of 60. The remaining items with standard deviation less than zero also showed differential difficulty indices between the two groups examined.

It was also discovered that all the items varied in discrimination indices between the two groups examined. Some values were positive while others were negative. In the urban students' assessment, 28 items had negative value while in the rural students', 23 items were found to have negative value out of 60 items. Items with negative discrimination indices are not good discriminations.

The sensitivity of DIF detection method varies among the multitude available. In this study, the Mantel-Haenszel (M-H) method was used. The M-H method has the ability to detect uniform DIF without using item response approach (Holland & Thayer, 1988). The M-H DIF analysis result showed each item's value (chi-square statistic and corresponding P-value). A total of six items (items 5, 12, 21, 22, 23, and 25) were flagged as DIF items. Based on the presence of the six DIF items, the null hypothesis was rejected.

## CONCLUSION AND RECOMMENDATION

From the findings of the study, items of the 2019 basic science BECE exhibited DIF when used during examination. This test was slightly easier for urban students and more difficult for rural students. In the light of this finding, it is recommended that before such and similar test items are used to assessment, thorough



investigation of items be conducted for possible DIF. If any item is flagged as DIF, it should be edited or eliminated to ensure the right quality instrument is designed and used. The same learning experiences should be provided for all JSS3 students across the state, as against the preferences enjoyed by the urban students.

## REFERENCES

1. Babcock, B., & Albano, A. D. (2011), *Rasch scale drift over time. Examining when to reset the scale. Paper presented at National Council on Measurement in Education, New Orleans L. A.*
2. Bock, Muraki E., & Pfeifferberger W. (1988). *Ham, pool maintenance in the presence of item parameter drift. Journal of Educational measurement, 25(24), 275-285.*
3. Bulut, O., Stanke, L., Rodriguez, M.C, Palma, J. R., Vue, K., & Cabrena, J.C. (2013). *Examining Item parameter Drift as a source of construct shift.*
4. Goldstein, H. (1983). *Measuring changes in educational attainment over time: Problems and possibilities. Journal of Educational Measurement, 20, 369 -377.*
5. Holland, P. W & Wainer H., (1993). *Differential Item Functioning. Rontledge, London UK.*
6. Holland, P. W., and Thayer, D. T. (1988). *Differential item performance and the Mantel-Haenszel procedure. In H. Wainer and H. I. Braun (ed.), Text validity. Hill sidale, NJ: Lawrence Erlbaum Associates.*
7. Li, X. (2008). *An investigation of the item parameter drift in the examination for the certificate of proficiency in English (ECPE). SPAAN FELLOW, 1001, 1*
8. Pine S. N., (1977). *Application of item characteristic curve theory to the problem of test bias. In Wollack, J. A., Sung, H. J., & Kang, T., (2005) Longitudinal effect of item parameter drift. Paper presented at the annual meeting of the National council; on Measurement in education. Montreal, Canada.*
9. Rizopoulos, D. (2006) *Itm: An R package for latent variable modelling and item response theory analyses. Journal of Statistical Software, 17(5), 1-25. URL <http://www.jstatsoft.org/v17/i05/>.*
10. Wollack sung, H.J & kang, T, (2006). *The impact of compounding item parameter drift on ability estimation. Paper presented at annual meeting of the National Council on Measurement in Education, san francisco*



# EFFECT OF CORPORATE COMPANIES IN INDIA POST COVID

**Ms. Parul Bhargava**

*Assistant Professor, S. S. Jain Subodh Management Institute, Jaipur*

## ABSTRACT

*The COVID-19 outbreak has put the global economic scenario out of order. The mechanism of lockdown and social distancing has paved a grave situation for global trade in general and services in particular as they are inseparable and requires proximity between the supplier and the consumer. In view of the outstanding contribution of services in India's foreign trade, this study examines the impact of the pandemic on aggregate, sectoral and mode-wise services exports from India. It ultimately seeks to highlight key opportunities, challenges and suggestions to protect and promote India's services interest amid this global disruption. We review the quarterly and monthly services exports patterns from January to July 2020 based on the data obtained from the World Trade Organization and the Reserve Bank of India. The perspective on mode-wise services exports is derived from the Trade-in Services by Modes of Supply (TISMOS) data set of the WTO for 2017. The analysis highlights a severe drop in overall services exports, by over 10% during the second quarter of 2020. Travel, transport and financial services have been hit hardest. However, the decline in India's services exports found as relatively much lower in comparison to other major services exporting economies. The comparative edge in digital or Mode 1 services offers greater opportunities for the country in the longer period if urgent policy initiatives and support are extended to potential online services sectors.*

**KEYWORDS:** COVID-19, Services Expose, Pandemic, Challenges, Opportunities, India

## INTRODUCTION

Covid-19 will change the way the world works; just like the Great Depression, dot-com bubble, and the 2008 financial crash did in the past. The question on everyone's mind is, 'Will things go back to normal?'

I've been pondering, like many have, what fundamental changes will take place in how people, businesses, and economies function. The next 12 months will be difficult. Many businesses will struggle, some may even die. But as with economic adversities of the past, new industries will emerge bringing with it renewed hope of recovery. Eventually, things will go back to normal. Just that we'll have to change the definition of normal.

Welcome to the New Normal.

In this article, I will explore the impact of COVID-19 on the Indian economy. If you'd like to understand what this means for investors, read my article about investing during COVID.

## A BRIEF HISTORY OF PANDEMICS

This infographic on the history of pandemics is insightful and hence I won't touch upon it.

While Covid-19 may not have the scale of pandemics of the past (as of date), the economic

damage has and will continue to affect more people than the disease itself.

## WHERE IS THE EMERGENCY EXIT?

Studying past trends of similar infections can help in drawing inferences as to what might help us going forward. What would it take to see this pandemic through?

- Mass Vaccination
- Herd Immunity
- Social Distancing

There's a high likelihood we're 12 months away from a semblance of normalcy. The biggest worry is a mutating virus that brings wave upon wave of attacks, each deadlier than the other. During the course of time that Covid-19 lasts, businesses and the global economy will continue to be significantly impacted.

## LIFE IN THE TIME OF COVID

It might be a mouthful but here's a look at what's to come in the immediate future. Liquidity is expected to remain tight as the cost of borrowing in real terms will jump upwards. This is despite central banks' efforts to reduce interest rates. Banks and financial institutions will be under immense pressure as the fear of NPAs, insolvency and bankruptcies



increase multifold. The government will focus on meeting hyper demand for essential goods while non-essential businesses will focus on recovering their receivables/outstanding money due from debtors. New strategic alliances or business partnerships will not emerge during this period.

If these were lyrics to a song, the specific genre would be doom metal.

I don't want to sound like a pessimist – the road forward looks rough. While there are sectors and businesses that will benefit, the prognosis is rather grim. In my best guess, here are some of the sectors that will be adversely affected and others that will see an uptick.

#### ADVERSELY AFFECTED SECTORS

- Apparel & Textile will get hit adversely due to disruption in labour supply, raw material unavailability, working capital constraints

and restricted demand due to limited movement of people and purchasing ability.

- Auto sector (which includes automobiles and auto parts) will continue to face challenges on account of lack of demand, global recession and falling income levels.
- Aviation & Tourism is one sector which has the highest probability of going under without direct government intervention. In the next 12 months, it's highly unlikely people will travel for leisure apart from very essential travel.
- Shipping and Non-Food Retail – Non food retail chains and global shipping businesses will find this 12 month period very challenging.
- Building & Construction businesses are generally leveraged and hence will face the dual challenges of high-interest payments and lack of sales.

#### COMPARING DEBT TO EQUITY RATIO OF SECTORS

Sector	D/E Ratio
Real Estate	0.86
Information Technology	0.11
Consumer Staples (FMCG Food)	0.49
Financials (Investment Banking and Brokerage)	0.083

Broadly, anything which involves personal interaction will face problems in the next 12 months – real estate or big-ticket items/luxury products.

#### SECTORS WITH A POSSIBLE UPTICK

- Digital & Internet Economy: Online based products & services companies will find new takers
  - Ed-tech and Online Education along with firms involved with online-skill development
  - Online groceries
  - There will be a sudden spike in the demand for Content, with digital content being in demand more than ever.
- FMCG & Retail will benefit immensely. With continued fear, food-based retail chains, and companies catering to low-ticket consumption demand will emerge as winners.
- Speciality Chemicals: Firms dealing in Chemicals will see a jump due to increased demand for disinfectants, drugs and medicines.
- Pharma: Pharmaceutical firms are set to see growth in the near term.

Performance of Sectors during COVID-19

Line chart with 4 lines.

Sectoral data is from respective smallcases

View as data table, Performance of Sectors during COVID-19

The chart has 2 X axes displaying Time and values.

The chart has 1 Y axis displaying values. Range: 50 to 150.

Sectoral data is from respective smallcases6. Jan20. Jan3. Feb17. Feb2. Mar16. Mar30. Mar13. Apr27. Apr5075100125150.

#### PEERING INTO THE FUTURE

Predictions; Anyone can do it, everyone does. It doesn't cost anything and does no harm. Not in my line of work.

As an investment professional, I'm responsible for the management of over \$250+ million in client money. My job is to make bold predictions and then take calculated risks with the objective of growing my clients' capital. Like everyone else with an opinion, here are some of my thoughts on the New Normal for Business.

But before that, a disclaimer, I'm not a crystal-ball gazer and have no powers beyond my understanding of macro trends and financial markets. Take this with a pinch of salt. Here goes.

#### THE NEW NORMAL FOR BUSINESS

Hits the fan so that fertilizer can rain', an obscure relationship 'expert' & author, was thinking about global upheaval when she wrote those words. But relationships do have something in common with the current situation – heartbreak.





Many lives will be lost and millions more affected. Countries will introspect, businesses will realign. But as Jackie's 21st-century take on turning lemons into lemonade goes, there may be a silver lining. We may have to wait for the rain clouds to depart.

### CHINESE WHISPERS

Having seen off the worst of the coronavirus wrath, China is limping back to normal. They will continue to remain a dominant exporter of raw material as well as finished goods, but businesses will ensure dependency on China is reduced. With all the talk of this being China's moment, will they be able to capitalize?

### TECHNOLOGY & FUTURE OF WORK

Technology for many businesses, until today, was considered to be a support function with it being used to get to an end. This is set to change as technology will now become the frontline requirement in most organizations. Its importance will be comparable to that of revenue-generating functions – sales and business development.

Trends will accelerate. Automation will gain momentum as the spend on sophisticated IT infrastructure outpaces human resources. Job creation will be limited with more offers being rolled out on a contractual basis than on a full-time basis. This sort of gig economy will emerge in the emerging markets as well as the more developed markets. Work from home will be the new normal. Firms in some sectors will realise that employees working from home are equally productive as compared to when they are working from the office. This will also help in saving infrastructure costs.

Non-environment friendly businesses will be looked down upon in terms of business valuations and focus on ESG (environmental, social, governance) will be a new way forward. Cities have already started thinking about sustainable development models. New, more compact and agile value chains will emerge, as non-essential intermediaries are given a back seat. This will also drive employee/labour productivity and efficiency.

### BACK TO BASICS

Businesses will rethink their strategy of focusing on sales without profitability/profitability growth. Organizations claiming hefty valuations just on the basis of sales growth will no longer find buyers – focus on profit and profit growth will be the new normal

Data will become even more valuable, and with it, data misuse through AI will also become rampant. We're already seeing governments and private entities roll out contact tracing tools which have poor implementation and pose severe threats to

data security and privacy. As these entities have realized, data can play a huge role in limiting the impact of viral phenomena – diseases, protests, misinformation the list goes on.

Data and IT security will become even more important for businesses. Traditional businesses, including heavy industries, will find it difficult to survive without access to information that would help with optimization and extracting efficiency.

### TEMPORARY DEATH OF DEBT

Asset heavy businesses like the ones related to oil, commodities, infrastructure will move to an asset-light model where financing of their activity would happen through public trusts, REITS, INVITs like structures. Equity financing would take over debt financing as businesses become reluctant to take on leverage.

### ALL ABOUT THE MONEY

Finally, big financial conglomerates with large balance sheet exposure will become history. We'll see the emergence of specialized segmental lenders who will strive to make better lending decisions through AI & social intelligence. Traditional lenders will exit the game.

### MAJOR TRENDS – THEMATIC PLAYS

Countries like China & India stand to benefit from low crude-oil prices and a younger population which can kick in low-ticket consumption demand. While the world is currently dominated by right-wing politicians who propagate the concept of 'Make Local, Consume Local', the world will find comfort, once again, in the arms of capitalism. Free markets and abolishment of trade restrictions can be expected in the post-Covid era.

Money will ultimately win. Most businesses that manage to survive the Covid-era financially will have the ability to emerge victorious. As they say, "You need to live, to be in the game". Internet-based B2C businesses – lending, financial services, and need-based solutions will stand to gain. Once the world sees through this pandemic, there will be a jump in rental demand, entertainment, travel and tourism. The cement, transportation, construction material, waste management, metals and commodities sectors will also see an uptrend.

The paper industry is one that has the highest chances of getting wiped out as the world looks to adopt environmentally friendly ways to live. As stated earlier, digital will be the new normal.

### COVID-19 IMPACT ON INDIA'S ECONOMY: CHALLENGES & SOLUTIONS

There is no doubt that COVID-19 will have a large impact on the Indian economy. With respect to



India, the discussion can be bifurcated into 2 parts – India's economy, and its stock markets.

The recovery of the underlying economy will be slow, and it will take around 2 years for normalcy to come back across sectors. While the overall economy might take a hit because of the government lockdown, some sectors are set to see immense growth in the post-COVID era – FMCG, B2C specialised lenders, gold-dependent companies, food retail and pharmaceutical companies to name a few.

Stock markets have a mind of their own, formed by the collective emotions + intelligence of millions. They are often skewed and aren't the best indicators of the underlying economy. Stock markets will have a strong recovery, not due to the fundamentals strength, but due to global liquidity which is available for almost free (as interest rates tend to near zero). Availability of debt capital will be scarce in India, whilst equity capital will be available in plenty over a period of time.

#### WHAT CAN THE GOVERNMENT DO?

Like its counterparts across the globe, the Indian government has announced a slew of measures to prevent total collapse. However, it isn't enough. This works to alleviate some of the pain, not counter it. My 2 cents (or one barrel of oil) on what the government ought to do:

- Loosen its purse and spend money on infrastructure development –
- Public sector financial institutions need to be further capitalized and nudged by the RBI to lend out low-ticket loans below INR 1 Crore in the form of working capital to ensure that liquidity comes back into the system
- Banking sector needs to be nudged to pass on rate cuts induced by RBI to the borrowers
- Personal tax cuts & tax holidays for 6 – 12 months can be adopted to revive consumption, which will help spur economic growth

These are not an exhaustive list of measures but could help alleviate the impact of COVID-19 on the Indian economy while stimulating growth.

#### COVID-19'S IMPACT ON SOCIETY

Before we end, let's look at some of the behavioural/societal impacts that Covid-19 might have.

During the course of the pandemic, people will be using digital medium for content and entertainment. Events that require massive gathering of people – sports, music festivals, theatre, etc. will take a hit for the next 12 months.

As the world overcomes this pandemic, discretionary demand will pick up as people become

imprudent. Retail leverage in the world will hit new highs. The use of addictive material – tobacco, narcotics, alcoholic beverages will jump multifold.

The next 5 years are going to be the golden period for media and entertainment. 3D/4D chatrooms and conference rooms will emerge rapidly. The largest chunk of media spending will shift from television to digital. Print media will cease to exist.

Businesses will experience an increase in productivity due to reduced staff. Remote work will see an uptick. The burden on local transportation infra will ease. Fewer roads, less traffic & pollution.

#### CONCLUSION

This may be the time to reset. Never before has the world come to a standstill where one can pick apart the many moving pieces – like Tom Cruise in *Minority Report*. We have the opportunity to rethink everything. If we do things right, we may be able to fix challenges that face humankind – environmental damage, inequality etc.

More importantly, we must ensure something like this never happens again. History says that humankind has never learnt from history. Let's hope that it's a thing of the past.

"June or July will tell us which way the tide is turning. The shortage of vaccination is creating a little bit of setback.

Businesses will be keenly watching what the government does next on the economic front, although it has to first bring the healthcare crisis under control.

"Government needs to come out with a strong policy and create a strong investment climate; otherwise it would be very difficult for many sectors to continue operating...Last time corporate India came in and did whatever was needed, but I think this year they would not have the wherewithal," said Praveer Sinha, CEO, Tata Power.

The government needs to explore ways to revive private investments in these uncertain times if it wants to mitigate the economic impact of the second wave, feel global investors.

"When there is uncertainty and volatility, investment is held back and that is what we are seeing and that is why despite all the positive steps that should have helped private investments to happen, private investments haven't stepped up and that is really what we need to be thinking, about how we can bring in investments in these uncertain times," said Anita George, executive vice-president and deputy head of CDPQ Global, Canada's second largest pension fund.

To be sure, while the second wave is a grave concern, corporate India remains optimistic that the measures taken by the government last year and the Union budget has put in place the building blocks



needed to push growth. "What was good about the budget was that we decided to live with higher deficit and growth was recognized to be the need. India is still looking good. This can be a deterrent and, yes, we have to be well-prepared, but the service economy has been growing for India. In this pandemic, India has proved to be the best BCP (business continuity planning) site for services in the world," said Kaku Nakhate, president and country head-India at Bank of America.

Other measures enacted by the government such as increasing the FDI cap in insurance will also help the country attract long-term capital.

## REFERENCES

1. Agarwal, S., Krishnan, R. (2020)
2. Baker, S. (2020)
3. Baldwin, E., Tomiura, E. (2020)
4. Dhawan, S. (2020)



# ASSESSMENT OF DISASTER RISK REDUCTION MANAGEMENT OF PUBLIC SCHOOLS IN LUCBAN DISTRICT

**Arcanel F. Perez**

*Faculty, Paaralang Sekundarya ng Lucban Integrated School*

## ABSTRACT

*This study aimed to determine the Disaster Risk Reduction Program of Public High School in Lucban District. Specifically, it sought to answer the following questions: 1. What is the level of preparedness in the integration of Disaster Risk Reduction in terms of Curriculum content, Orientation, and Drills? 2. What is the level of preparedness in Disaster Management in terms of Responsiveness, Mitigation, and Rehabilitation? 3. Is there a significant effect in the Integration in Education and Disaster Management of the different public secondary schools in Lucban District?*

*The study was limited to the respondents of one hundred (100) Grade 12 students and twenty-eight (28) Grade 12 teachers of different public secondary high schools in Lucban District. The descriptive method of research was used to analyze the data systematically.*

*The research instrument in this study was a questionnaire checklist. It consists of an assessment of disaster risk reduction management in the following aspects: integration of disaster preparedness in education on curriculum content, orientation, and drills. Another set of questionnaires for school disaster management in the following aspects: responsiveness, mitigation, and rehabilitation was utilized.*

*The result of the study shows that there is a strong relationship between the integration of Disaster Preparedness in Education ( $r=0.800, p=0.000$ ) and disaster management of public secondary schools. Thus, the hypothesis stating that there is no significant effect between the integration of disaster preparedness in Education and Disaster Management of different Public High Schools in Lucban District was rejected.*

*Based on the findings, it was concluded that the integration of disaster preparedness in education as to curriculum content, orientation and drills, and disaster management and responsiveness, mitigation, and rehabilitation is a concern that affects school administration, action, and planning in the school implementation plan. It is recommended that the school head should continue adapting programs for disaster management, an annual implementation plan should review most of the time and a rigorous rehabilitation plan should be implemented to avoid interruption on students learning.*

*Curriculum developers should continue providing the educational system the most updated instructional material related to disaster preparedness for the most comprehensive and reliable teaching reference. Teachers must abreast their knowledge and capability in disaster preparedness and mitigation to impart active and continuous learning. If necessary attend seminars or webinars in disaster-related courses. Schools may intensify the DRRM through SLAC (School Learning Action Cell). The LGU (Local Government Unit) may strengthen its partnership with other external stakeholders and other agencies for the support and technical assistance that will provide the school comprehensive background in disaster management.*

## INTRODUCTION

The Philippines is one of the countries that experience numerous disasters yearly. Throughout recorded history, it is considered one of the most disaster-prone countries in the world. Considering its geographical location, it is exposed to various natural hazards of earthquakes, volcanic eruptions, landslides, floods, and typhoons. Indeed, an average of 20 earthquakes per day and 20 typhoons visits the country every year.

Disaster may be considered as man-made or natural. It usually happens when we are not prepared.

In effect, it greatly affects our daily life in terms of economic, social, physical, and cultural aspects. It is also seriously disrupting the functions of community or society and causes—human, material or economic or environmental losses that exceed to community's or society's using its ability to cope using its resources. Though often caused by nature, disaster can have a human origin.

The Department of Education as one of the pillars of the society strictly implements what is mandated by the constitution, one of which is to ensure always the safety of the students.



According to R.A. 10121 also known as the Philippine Disaster and Risk Reduction Management Act of 2010, DEPED should manage and mobilize resources for disaster risk reduction and management including the National Disaster Risk Reduction and Management Fund.

As one of the bases for this study, DO 37, S. 2015 – The Comprehensive Disaster Risk Reduction and Management (DRRM) in the Basic Education Framework which guides the DRRM efforts in the basic education sector towards resilience-building in offices and schools, and to ensure that quality education is continuously provided and prioritized even during disasters and/or emergencies.

In addition, we must develop a strong program for disaster management since we cannot predict what might happen in the future especially now that the expert is predicting the occurrence of BIG ONE that will surely affect the greater area of Luzon. Public schools play a vital role in disaster preparedness, mitigation, and rehabilitation. It serves as a rehabilitation center when disaster strikes. It is a must to exert all effort to provide the school all the preparation and awareness for disaster. Let us prepare for the worst expect the better. Hence, it is important to be ready as the saying goes “LIGTAS ANG MAY ALAM.”

## RESEARCH METHODOLOGY

This chapter is a discussion of methods and procedures observed in the conduct of the study. It includes the research design, respondents of the study, sampling technique, research procedure, research instrument, and statistical treatment.

### Research Design

This study determined the Assessment of Disaster Risk Reduction Management of Lucban District. The descriptive method was used to collect and analyze the data about this study.

### Respondents of the Study

This study was limited to selected Senior high students and teachers who served as the respondents of this study from the two public high schools in Lucban District namely: Paaralang Sekundarya ng Lucban Integrated School (PSLIS) and Nagsinamo National High School.

### Purposive Sampling Technique

The purpose of selecting one hundred fifty (100) Senior High School Students and twenty-eight (28) Senior High School Teachers was to get the data about disaster preparedness and its importance in school disaster risk reduction program among Public Secondary Schools in Lucban, Quezon.

Paaralang Sekundarya ng Lucban Integrated School Grade 12-Senior High School Students

Male	Female	Total
173	213	386

Nagsinamo National High School

Male	Female	Total
10	7	17

### Research Procedure

The researcher will ask permission from the superintendent of DepEd Quezon Province and the Principal of two public high schools in Lucban district to conduct his research. Administering the questionnaire to the respondents is the main source of information in this research. The researcher explained to the respondents the purpose of the study and assure the confidentiality of their answers. Data from the collected questionnaire were carefully analyzed to interpret, analyze and make suggestions and recommendations.

### Research Instrument

The main tool in this study was a questionnaire checklist. A set of questionnaire checklists was constructed for teachers and students respondent. It consists of the assessment of disaster risk reduction management in the following aspects:

integration of disaster preparedness in education on training and drills. This also includes another set of questionnaires for school disaster management in the following aspects: responsiveness, mitigation, and rehabilitation. It will obtain the level of preparedness in different aspects: 5-highly prepared, 4- moderately prepared, 3-prepared, 2-quite prepared, and 1-not prepared. The questionnaire was formulated and after it was returned, after it was checked the researcher will ask the permission of the school principal so that the researcher is allowed to conduct data gathering to the respondents.

### Statistical Treatment of Data

The respondent’s answers were tabulated as the basis for the statistical treatment of data of the present study.

Mean and standard deviation was used to determine the mean level of integration disaster





reduction in education in terms of curriculum content, orientation, and drills.

To determine the mean level of preparedness on disaster risk reduction in terms of responsiveness, mitigation, and rehabilitation Mean and Standard Deviation were used.

While the significant effect in the Disaster Risk Reduction Program and Disaster Management of the different public secondary schools in Lucban district was determined by using correlation analysis.

## RESULTS AND DISCUSSIONS

**Table 7. Effect of Integration of Disaster Preparedness in Education on Disaster Management of Public Secondary Schools as to Responsiveness**

Indicator	R	Interpretation	P	Analysis
Integration of Disaster Preparedness				
<i>Curriculum Content</i>	0.766	Strong	0.000	Significant
<i>Orientation</i>	0.800	Very Strong	0.000	Significant
<i>Drill</i>	0.756	Strong	0.000	Significant

*Adjusted R<sup>2</sup> 0.698*

Results of the study show that there is a very strong relationship between the integration of Disaster preparedness in education as to orientation ( $r=0.800$ ,  $p=0.000$ ) and disaster management as to responsiveness of public secondary schools. Strong relationship, however, is seen between curriculum content ( $r=0.766$ ,  $p=0.000$ ), drill ( $r=0.756$ ,  $p=0.000$ ) and responsiveness. Such a relationship is found highly significant ( $p<0.01$ ). Subjected to regression analysis, it shows that 69.8% of the variance of the disaster management of public secondary schools as to responsiveness is explained by the variance of the integration of disaster preparedness in education in terms of curriculum content, orientation, and drills.

Shelton (2011) further added that emergency preparedness and responses must be woven into every aspect of the built learning space. He pointed out that the goal is to reduce risk and address a plethora of threats by creating circles of protection. Risk Reduction is recognized as vital for building a more equitable future and for reducing the severity of losses during disasters. Effective risk reduction occurs when there is a cooperation between sectors of society and there is an existing disaster preparedness program in place. (Lopez and associates,2018). It is a must to be responsive at all times not only in times of disaster but also at all times.

**Table 8. Effect of Integration of Disaster Preparedness in Education on Disaster Management of Public Secondary Schools as to Mitigation**

Indicator	R	Interpretation	P	Analysis
Integration of Disaster Preparedness				
<i>Curriculum Content</i>	0.757	Strong	0.000	Significant
<i>Orientation</i>	0.765	Strong	0.000	Significant
<i>Drill</i>	0.775	Strong	0.000	Significant

*Adjusted R<sup>2</sup> 0.674*

Results of the study show that there is a very strong relationship between the integration of Disaster preparedness in education as to orientation ( $r=0.800$ ,  $p=0.000$ ) and disaster management as to responsiveness of public secondary schools. Strong relationship, however, is seen between curriculum content ( $r=0.766$ ,  $p=0.000$ ), drill ( $r=0.756$ ,  $p=0.000$ ) and responsiveness. Such a relationship is found highly significant ( $p<0.01$ ). Subjected to regression analysis, it shows that 67.4% of the variance of the disaster management of public secondary schools as to mitigation is explained by the variance of the integration of disaster preparedness in education in terms of curriculum content, orientation, and drills.

Shelton (2011) further added that emergency preparedness and responses must be woven into every aspect of the built learning space. He pointed out that the goal is to reduce risk and address a plethora of threats by creating circles of protection. Mitigation activities reduce or eliminate the damages from hazardous events. These activities can occur before, during, and after a disaster and overlap all phases of emergency management. The idea was taken from the study of Atienza (2016). It is also reflected based on the findings that almost all schools become responsive in times of disaster.



**Table 9. Effect of Integration of Disaster Preparedness in Education on Disaster Management of Public Secondary Schools as to Rehabilitation**

Indicator	R	Interpretation	P	Analysis
Integration of Disaster Preparedness				
<i>Curriculum Content</i>	0.641	Strong	0.000	Significant
<i>Orientation</i>	0.622	Strong	0.000	Significant
<i>Drill</i>	0.670	Strong	0.000	Significant

*Adjusted R<sup>2</sup>*     **0.471**

Results of the study show that there is a strong relationship between the integration of Disaster preparedness in education as to orientation ( $r=0.800$ ,  $p=0.000$ ) and disaster management as to rehabilitation of public secondary schools. Strong relationship, however, is seen between curriculum content ( $r=0.766$ ,  $p=0.000$ ), drill ( $r=0.756$ ,  $p=0.000$ ) and responsiveness. Such a relationship is found highly significant ( $p<0.01$ ). Subjected to regression analysis, it shows that 4.71% of the variance of the disaster management of public secondary schools as to rehabilitation is explained by the variance of the integration of disaster preparedness in education in terms of curriculum content, orientation, and drills.

Health-related rehabilitation begins with the onset of injury or disease and can extend over a lifetime often involving treatment in the hospital, community, and home settings. Since a person's functional needs require attention in the immediate living environment as well as in the greater community.

As mentioned in the related literature, the government and the school must see to it that the rehabilitation process would take place after disaster strikes and it should not delay nor affect the education process.

Based on the data gathered, it shows that the null hypothesis stating that "There is no significant effect between disaster risk reduction integration in education and disaster management of the different public secondary schools in Lucban district" was rejected. The conclusion derived that: there is a "significant" effect to develop a program in disaster preparedness in education in times of disaster in determining its implication to disaster risk reduction management in terms of responsiveness, mitigation, and rehabilitation.

## CONCLUSIONS

Based on the findings, the following conclusions were drawn:

1. The integration of Disaster preparedness in education as to orientation and disaster management and responsiveness of public secondary schools is a concern that affects school administration especially in creating a program that will be suited to DepEd's mandate on the inclusion of disaster preparedness subject on the curriculum.

2. The integration of Disaster preparedness in education as to orientation and disaster management and mitigation of public secondary schools is a concern that affects school action and planning in the school implementation plan.

3. The integration of Disaster preparedness in education as to orientation and disaster management and rehabilitation of public secondary schools is a concern that has a significant relationship because disaster can cause a delay in students learning.

4. Based on the data gathered, it shows that the null hypothesis stating that "There is no significant effect between disaster risk reduction integration in education and disaster management of the different public secondary schools in Lucban district" was rejected. The conclusion derived that: there is "significant" effect to develop a program in disaster preparedness in education in times of disaster in determining its implication to disaster risk reduction management in terms of responsiveness, mitigation, and rehabilitation.

## RECOMMENDATIONS

In view of the results of this study, the following was recommended:

1. School head may continue adapting programs for disaster management not only for compliance but it secure safety and security in the learning environment.

2. Annual school implementation plan in relation to rehabilitation and maintenance may undergo review most of the time to see if it is updated especially nowadays where disaster increases for both man-made and natural.

3. School may implement rigorous rehabilitation plan to avoid delay in students learning and should be included in LCP (Leaning Continuity Plan).

4. Curriculum developers may continue providing the educational system the most updated instructional material related to disaster preparedness for the most comprehensive and reliable teaching reference.

5. Teachers may abreast their knowledge and capability in disaster preparedness and mitigation to impart active and continuous learning. If



necessary, attend seminars or webinars in disaster-related courses.

6. Schools may intensify the DRRM system through SLAC (School Learning Action Cell).

7. The Local Government Unit (LGU) may strengthen its partnership with other external stakeholders and external other agency for the support and technical assistance about DRRM that will provide the school comprehensive background in disaster management.

## REFERENCES

1. Atienza, Jouenna Marie S. (2016). *Risk Reduction Management of DEPED Schools in CALABARZON: A Disaster Response and Governance THESIS*
2. Barakat, B., Bengtsson, S., Muttarak, R., & Kebede, E.B. (2016). *Education & the Sustainable development goals (background paper prepared for the 2016 global education monitoring report)*. Paris, UNESCO
3. Brunello et.al. 2015, *The causal effect of education on health; What is the role of health behaviors?* Health Economics, <https://dx.doi.org/10.1002/hec.3141>.
4. Chou, Y-J, Huang, N., Lee, C.-H., Tsai, S, L., Tsay, J.H. & Chou, P. (2003) *Suicides after Taiwan Earthquake*. *International Journal of Epidemiology*, 32(6), 1007-1014 doi:10.1093/ije/dyg296
5. Cutter S. 2013. *Building disaster : resilience; steps toward sustainability, Challenges in sustainability 1(2)*, 72.
6. *Deped Order No.21 s.2015 Disaster Risk Reduction and Management Coordination and Information Protocol*.
7. Greccalda, Ray Samuel (2013). *"Social Services Delivery of Local Government Units in the Municipality of Santa Cruz, Laguna"*. Laguna . Laguna State Polytechnic University THESIS International Federation of Red Cross and Red Crescent Societies
8. Lopez A., Echavez N., Magallen J., & Sales E.; 2018 *Level of Compliance with the Risk Reduction and Preparedness Program among Public Secondary Schools in Buenavista, Bohol, Philippines*
9. Mamon M., Suba R., Lakipson I. Jr., *Disaster Risk Reduction Knowledge of Grade 11 Students: Impact of Senior High School Disaster Education in the Philippines*.
10. Maxwell. F.J. 2012. *A Holy Challenge: Harnessing Practical Imagination in Places of Conflict, Disaster and Development*. Sofia University
11. Monami, N. M., & Salmi, A. (2012). *Preparedness of Schools in the Province of Jeddah to deal with earthquakes risks*. *Disaster prevention and Management: An International Journal*, 21(4), 463-473.
12. Muttarak, R., & Pothisiri, W. (2013). *The role of Education in disaster preparedness: Case study of 2012 Indian Ocean Earthquake on Thailand's Andaman Coast*, *Ecology and Society*, 18(4), 51 <http://dx.doi.org/10.5751/ES-06101-18045>.
13. Paton, Douglas. *Disaster Resilient Communities: Developing and Testing an All- Hazards Theory*. Published online: 01/06/2013
14. Rambau, T.S., Beukes, L.D., & Fraser, W. (2012). *Disaster Risk Reduction through school learners' awareness and preparedness*. *Jámbá: Journal of Disaster Risk Studies*, 4(1), 1-11.
15. R.A. 10121 of 2010 *Philippine Disaster Risk Reduction and Management Act of 2010 Sendai Framework (Hyogo Framework for Action)*
16. Shaw, R., Shiwaku Hirohide Kobayashi, K., & Kobayashi, M. (2004) *Linking experience, education, perception and earthquake preparedness* *Disaster Prevention and Management: An International Journal*, 13(1).
17. Sinha, A., Pal, D.K., Kasar, P.K., Tiwari, R., & Sharma, A. (20018). *Knowledge, attitude and practice of disaster preparedness and mitigation among medical students*. *Disaster Prevention and Management: An International Journal*, 17(4), 503-507 Retrieved from <https://goo.g/uD6q5B>.
18. Skinner, B.F. (2014). *Contingencies of Reinforcement: A Theoretical analysis (vol.3)*. BF Skinner Foundation. Retrieved from <https://goo.g/3Rfctc>.
19. Smith, T. M., Drefus, A., & Hersch, G. (2011). *Habits, routines and roles of graduate students: The effects of Hurricane Ike*. *Occupational Therapy in Health Care*. 25(4), 283-297. doi:10.3109/07380577.2011.600426.
20. Tuladhar, G., Yatabe, R., Dahal, R., & Bhandary, N. (2015). *Assessment of disaster risk reduction knowledge of school teachers in Nepal*. *International Journal of Health System and Disaster Management*, 3(1), 20. UNISDR. *United Nation International Strategy for Disaster Reduction WHO. (2007) World Health Organization Benchmarks, standards and indicators*



## A STUDY ON CONSUMER BUYING PREFERENCES OF CARS WITH REFERENCE TO SELECTED CITIES FROM TELANGANA AND ANDHRA PRADESH

<sup>1</sup>Dr. Shaik Shamshuddin, <sup>2</sup>Dr. T.Venkateswarulu

<sup>1,2</sup>Assistant Professor, GITAM Institute of Management, GITAM Deemed to be University, Visakhapatnam, Andhra Pradesh, INDIA

### ABSTRACT

Automobile industry was supported with the latest technologies, skilled workforce significant investment of direct and indirect all these had shown the considerable growth in the Indian Car consumer market. The automobile industry got its new regime and boom. With the increase of middle class group people's income level, the car purchases knocked the market with more customers joining together in India's ordinary car segment. In India, we have more ordinary customers purchasing these people choose the cars like Maruti Suzuki, Hyundai, Tata, etc.; based on an extensive review of the Literature, the questionnaire was designed by taking the various outcomes of the study. Google sheets and schedules were both distributed to the identified customers in the Car market. Mostly the study focussed on the buying preferences of the customers. The study also concentrated on the various segments in the Car market.

**KEYWORDS:** Segment, Brand, Hatchback, Sedan, Market, Consumer.

### A. INTRODUCTION

A few decades back, Car was a Luxury product, but today Car is not a luxury but a necessity. The first Car was rolled out in India in 1897, and till the year 1930, all the cars were imported from foreign countries. The automobile industry mainly emerged in India in 1940. Hindustan Motors Limited (HML) by Birlas collaborated with Lord Nuffield of Morris motors launched the first Car. Premier company (Premier automobile Limited) Walchand Hirachand, who were founders of the car company in India, started in Mumbai and competed with HML. Gradually lots of the companies entered India and established their plants here, and grabbed the most significant market. Earlier the long and big cars were the passion for the luxury consumers. Because of the increased traffic and number of car owners, it was also perceived and preferred that a small car is most desirable for Indian roads and traffic conditions. In India, there are few top brands in the car segment Maruti Suzuki, Hyundai, Toyota, Mahindra, and Tata Motors. The majority of the cars sale in India is bagged with Maruti Suzuki, again Maruti Suzuki Swift stood as largest selling Car in 2020 with 18,498 cars were sold in last 2020. The Indian Car market is one of the important market and trading areas globally, with the third power purchasing parity in the world. No the cars like BMW, Mercedes Benz, Volvo, Audi also launching the cars between 30 to 50 lacks for Indian consumers. This shows the necessity rather than brand preference. There are three types of Cars like Luxury, Semi Luxury, and Ordinary. Because of LPG (liberalization, Privatisation, and globalization), in 1991 Automobile industry got its new regime and boom. With the growth of middle-class group people's income level, the car purchases knocked the market with more customers joining together in India's ordinary car segment.

In India, we have more ordinary customers purchasing these people choose the cars like Maruti Suzuki, Hyundai, Tata, etc., Generally, the companies like Maruti Suzuki and Hyundai have more loyal customers. Here this study is focussing on the preference of the types of cars in the ordinary car segment. The study was conducted only for customers belongs the everyday car segment in India. Only selected brands were taken for the task.

### 1 REVIEW OF LITERATURE

Joseph Camble (2011) in present study, the data was collected from more than 500 customers connected in Karnataka state and found that one of the most significant areas is the financial aspects to purchase the Car. In this study, Sharma (2006) believed that the internet revolution, which provided all the information and increased



the interest of the customer to know and compare various aspects of the car segment, automatically enhanced the Car's purchases in India. Becker (2013) studied the supportive and encouraging environment for car production and car market growth. Likewise, Belch and Belch(2007) point out that it encompasses the people's activities and processes when selecting, searching for, buying, using, disposing, and evaluating products and services to fulfill their desires and needs. Hoyer and MacInnis (2008) explain consumer behavior as the totality of decisions made by the consumers concerning consumption, acquisition, and disposition of time, services, goods, people, activities, ideas, and experiences by (human) units of decision-making. Vijay Bhaskar (2013), in his study related to the Car market growth in India, perceived that India is one of the largest and significant markets for ordinary cars, the increase of FDI substantially developed the car market in India. Cars Purohit (2009) identified that the most significant factors are the brand, driving comfort, spare parts availability, etc., Salvi and Prajapati (2015) reviewed that models, external and internal features satisfaction levels are the significant components of the buying the Car in Indian car consumer scenario. Thomas (2018) apart from all other factors that influence the buying or purchasing of the car finance is one of the essential factors that influence the purchase in India, especially the middle class and mid-range cars in India. Goyal (2016), in study, it was identified that the cost-effectiveness of the fuel alternative like CNG and LPG tends the consumers to buy the gas driven vehicles which perceive as one of the affordable and alternative for both petrol and diesel.

## 2 OBJECTIVES OF THE STUDY

- To study the various indicators which are supporting the Indian Car market.
- To study the reasons for the slowdown in the automobile Industry in India
- To study the preferences of the auto Mobile customers related to ordinary cars in India.
- To study the consumer behavioral pattern and choices while purchasing the Car in India.

## 3 RESEARCH METHODOLOGY

Based on extensive review of the Literature, the questionnaire was designed by taking the study's various outcomes. Google sheets and schedules were both distributed to the identified customers in the Car market. Primarily the study focussed on the buying preferences of the customers. The study on Consumer preferences of a car with selected brands and selected cities from Andhra Pradesh and Telangana. The total sample chosen from the three districts- Hyderabad, Vijayawada, and Visakhapatnam, was 900.

## 4 DATA ANALYSIS

i. District-wise respondents:

Age	No of respondents	Percent
Hyderabad	385	46.0
Vijayawada	210	25.0
Visakhapatnam	242	29.0
<b>Total</b>	<b>837</b>	<b>100.0</b>

ii. Age-wise classification:

Age	Respondents	Percent
Below 18 years	51	6.1
18-24 years	114	13.6
25-34 years	179	21.4
35-40 years	250	29.9
41-60 years	222	26.5
Above 60 years	21	2.5
<b>Total</b>	<b>837</b>	<b>100.0</b>





iii. Marital Status:

Marital Status	Respondents	Percent
Single/Unmarried	267	31.9
Married	570	68.1
<b>Total</b>	<b>837</b>	<b>100.0</b>

Source: Primary Data

iv. Income wise:

Household Income (in rupees)	Respondents	Percent
Below 30000	129	15.4
30001-60000	144	17.2
60001-90000	217	25.9
Above 90000	347	41.5
<b>Total</b>	<b>837</b>	<b>100.0</b>

Occupation wise classification of Respondents:

Occupation	Respondents	Percent
Government employee	193	23.1
Industrialist	151	18.0
Private employee	170	20.3
Self-employed	183	21.9
Professional	78	9.3
Agriculture	50	6.0
Others	12	1.4
<b>Total</b>	<b>837</b>	<b>100.0</b>

Nature of family-wise classification of Respondents:

Nature of Family	Respondents	Percent
Nuclear	694	82.9
Joint	143	17.1
<b>Total</b>	<b>837</b>	<b>100.0</b>

v. The opinion of respondents about media through which they came to know about cars:

Media Source	Respondents	Percent
Television	526	62.8
Radio	17	2.0
Newspaper	52	6.2
Pamphlet	26	3.1
Magazine	26	3.1
Friends/Neighbours	69	8.2
Shop Display	91	10.9
Any other	30	3.6
<b>Total</b>	<b>837</b>	<b>100.0</b>

Factors influencing the buying decision of cars.

Factors	1	2	3	4	5	6	7	8	9	Total	Total Score	Mean Score
Colour	184	420	11	8	88	8	25	67	26	837	5848	6.99
Range	485	181	9	16	24	84	8	7	23	837	6489	7.75
Credit Facility	33	93	407	186	8	6	86	10	8	837	5356	6.40
Dealer	7	27	274	8	76	424	7	5	9	837	4361	5.21
Price and quality	13	88	56	420	8	204	16	17	15	837	4686	5.60
Popularity	78	4	56	5	433	8	238	10	5	837	4092	4.89
Warranty	7	5	8	90	7	13	30	672	5	837	2225	2.66
Discount	21	9	8	97	192	10	19	27	454	837	2464	2.94
Bundled schemes	8	13	11	7	8	80	396	21	293	837	2178	2.60



vi. Promotional offer preferences of respondents (Rank Order)

Type of discount	1	2	3	4	Total	Total Score	Mean Score
Price Discount	335 (40.0)	244 (29.2)	247 (29.5)	11 (1.3)	<b>837 (100.0)</b>	<b>2577</b>	<b>3.08</b>
Free Accessories	422 (50.4)	262 (31.3)	85 (10.2)	68 (8.1)	<b>837 (100.0)</b>	<b>2712</b>	<b>3.24</b>
Bundled offer with extended Warranty	20 (2.4)	165 (19.7)	460 (55.0)	192 (22.9)	<b>837 (100.0)</b>	<b>1687</b>	<b>2.02</b>
Free Gift	61 (7.3)	167 (20.0)	51 (6.1)	558 (66.7)	<b>837 (100.0)</b>	<b>1405</b>	<b>1.68</b>

vii. Factors influencing buying decisions of Cars

Factors	Strongly disagree	Disagree	Neither agree nor disagree	Agree	Strongly agree	Total
Changing financial position	148 (17.7)	225 (26.9)	227 (27.1)	165 (19.7)	72 (8.6)	<b>837 (100.0)</b>
Social Status	161 (19.2)	162 (19.4)	113 (13.5)	310 (37.0)	91 (10.9)	<b>837 (100.0)</b>
Comfort Transport	95 (11.4)	30 (3.6)	73 (8.7)	316 (37.8)	323 (38.6)	<b>837 (100.0)</b>
New Model Passion	63 (7.5)	87 (10.4)	116 (13.9)	399 (47.7)	172 (20.5)	<b>837 (100.0)</b>
Colour and Range	84 (10.0)	24 (2.9)	73 (8.7)	267 (31.9)	389 (46.5)	<b>837 (100.0)</b>
Eco Friendly	53 (6.3)	143 (17.1)	90 (10.8)	330 (39.4)	221 (26.4)	<b>837 (100.0)</b>
Family Pressure	107 (12.8)	96 (11.5)	133 (15.9)	341 (40.7)	160 (19.1)	<b>837 (100.0)</b>
Sales and promotional activities	76 (9.1)	209 (25.0)	255 (30.5)	191 (22.8)	106 (12.7)	<b>837 (100.0)</b>
Low-unit price	88 (10.5)	186 (22.2)	238 (28.4)	183 (21.9)	142 (17.0)	<b>837 (100.0)</b>
Impressed by advertisements	66 (7.9)	193 (23.1)	274 (32.7)	253 (30.2)	51 (6.1)	<b>837 (100.0)</b>
To attain attention from friends	139 (16.6)	133 (15.9)	283 (33.8)	194 (23.2)	88 (10.5)	<b>837 (100.0)</b>
Impress others	190 (22.7)	186 (22.2)	225 (26.9)	186 (22.2)	50 (6.0)	<b>837 (100.0)</b>
Inherent features and attributes	109 (13.0)	116 (13.9)	344 (41.1)	171 (20.4)	97 (11.6)	<b>837 (100.0)</b>

viii. Influence of Branding Decisions in the process of buying a Car

Brand Decision maker	Respondents	Percent
Father/Father-in-law	353	42.2
Mother/Mother-in-law	232	27.7
Husband	68	8.1
Wife	53	6.3
Children	30	3.6
All the above	101	12.1
<b>Total</b>	<b>837</b>	<b>100.0</b>

Source: Primary Data



ix. Factors influencing brand decision while purchasing Cars at Showroom

Factors	SDA	D	N	A	SA	Total	Total score	Mean score
Car Display	158 (18.9)	166 (19.8)	168 (20.1)	192 (22.9)	153 (18.3)	837 (100.0)	2527	3.02
Car Endorsed	145 (17.3)	238 (28.4)	279 (33.3)	99 (11.8)	76 (9.1)	837 (100.0)	2234	2.67
Car Range	114 (13.6)	93 (11.1)	233 (27.8)	294 (35.1)	103 (12.3)	837 (100.0)	2690	3.21
Recommended by Dealer	82 (9.8)	264 (31.5)	206 (24.6)	231 (27.6)	54 (6.5)	837 (100.0)	2422	2.89
Advertisement	70 (8.4)	151 (18.0)	304 (36.3)	233 (27.8)	79 (9.4)	837 (100.0)	2611	3.12
Views of other customers	63 (7.5)	207 (24.7)	239 (28.6)	216 (25.8)	112 (13.4)	837 (100.0)	2618	3.13
Car availability	86 (10.3)	110 (13.1)	135 (16.1)	380 (45.4)	126 (15.1)	837 (100.0)	2861	3.42
Reviews	70 (8.4)	205 (24.5)	228 (27.2)	255 (30.5)	79 (9.4)	837 (100.0)	2579	3.08
Discount	102 (12.2)	147 (17.6)	229 (27.4)	268 (32.0)	91 (10.9)	837 (100.0)	2610	3.12

x. Attributes of the Car

Response	Very important	Important	Neutral	To some extent, important	Unimportant	Total
Look	576 (68.8)	181 (21.6)	39 (4.7)	11 (1.3)	30 (3.6)	837 (100.0)
Style	633 (75.6)	115 (13.7)	20 (2.4)	21 (2.5)	48 (5.7)	837 (100.0)
Preferred Colour	279 (33.3)	260 (33.3)	185 (22.1)	68 (8.1)	45 (5.4)	837 (100.0)
Speed	272 (32.5)	193 (23.1)	219 (26.2)	58 (6.9)	95 (11.4)	837 (100.0)
Milage	571 (68.2)	126 (15.1)	26 (3.1)	67 (8.0)	47 (5.6)	837 (100.0)
Internal Look	501 (59.9)	159 (19.0)	115 (13.7)	21 (2.5)	41 (4.9)	837 (100.0)
External Look	325 (38.8)	239 (28.6)	111 (13.3)	110 (13.1)	52 (6.2)	837 (100.0)
comfort	191 (22.8)	156 (18.6)	177 (21.1)	114 (13.6)	199 (23.8)	837 (100.0)
Safety	163 (19.5)	151 (18.0)	136 (16.2)	165 (19.7)	222 (26.5)	837 (100.0)
Influenced by Advertisement	122 (14.6)	150 (17.9)	153 (18.3)	196 (23.4)	216 (25.8)	837 (100.0)
Bundle of others	187 (22.3)	131 (15.7)	262 (31.3)	103 (12.3)	154 (18.4)	837 (100.0)

xi. Marital status based brand preferences of Car

Bathing soap	Marital status		Total
	Single/Unmarried	Married	
Jazz	20 (7.5)	45 (7.9)	65 (7.8)
Dettol	9 (3.4)	23 (4.0)	32 (3.8)
Honda Amaze	7 (2.6)	16 (2.8)	23 (2.7)
Honda City	31 (11.6)	80 (14.0)	111 (13.3)
Hyundai Santro	37 (13.9)	67 (11.8)	104 (12.4)
Tata Tigor	2 (0.7)	11 (1.9)	13 (1.6)
Maruti Swift	37 (13.9)	88 (15.4)	125 (14.9)
Hyundai 120	14 (5.2)	33 (5.8)	47 (5.6)
Nissan Micra	10 (3.7)	30 (5.3)	40 (4.8)
Renault Kwid	40 (15.0)	78 (13.7)	118 (14.1)
Maruti Alto 800	60 (22.5)	99 (17.4)	159 (19.0)
<b>Total</b>	<b>267 (100.0)</b>	<b>570 (100.0)</b>	<b>837 (100.0)</b>
<b>Chi-square value</b>	<b>7.34, df = 10, Table Value = 18.3</b>		

xii. Income based preferences

Car	Household income				Total
	Below 30000	30000-60000	60001-90000	Above 90000	
Maruti Alto 800	67 (51.9)	111 (77.1)	128 (59.0)	230 (66.3)	536 (64.0)
Hyundai I 10	13 (10.1)	5 (3.5)	24 (11.1)	21 (6.1)	63 (7.5)
Honda Amaze	16 (12.4)	11 (7.6)	6 (2.8)	14 (4.0)	47 (5.6)
Maruti Swift	15 (11.6)	2 (1.4)	24 (11.1)	26 (7.5)	67 (8.0)
Honda City	10 (7.8)	0	13 (6.0)	10 (2.9)	33 (3.9)



Tata Tigor	1 (0.8)	1 (0.7)	4 (1.8)	16 (4.6)	<b>22 (2.6)</b>
Nissan Micra	0	2 (1.4)	5 (2.3)	9 (2.6)	<b>16 (1.9)</b>
Any other	7 (5.4)	12 (8.3)	13 (6.0)	21 (6.1)	<b>53 (6.3)</b>
<b>Total</b>	<b>129 (100.0)</b>	<b>144 (100.0)</b>	<b>217 (100.0)</b>	<b>347 (100.0)</b>	<b>837 (100.0)</b>
<b>Chi-square value</b>	<b>73.74**, df = 21, Table Value = 38.9</b>				

\*\* Significant at 1% level.

xiii. Occupation wise brand preferences of Car

Brand Car	Occupation							Total
	Government employee	Industrialist	Private employee	Self-employed	Professional	Agriculture	Others	
Maruti Swift	28 (14.5)	16 (10.6)	16 (9.4)	15 (8.2)	9 (11.5)	4 (8.0)	3 (25.0)	<b>91 (10.9)</b>
Maruti Alto 800	49 (25.4)	44 (29.1)	40 (23.5)	44 (24.0)	18 (23.1)	13 (26.0)	6 (50.0)	<b>214 (25.6)</b>
Hyundai Santro	14 (7.3)	18 (11.9)	16 (9.4)	14 (7.7)	10 (12.8)	5 (10.0)	0	<b>77 (9.2)</b>
Tata tigor	5 (2.6)	-	8 (4.7)	7 (3.8)	4 (5.1)	2 (4.0)	0	<b>26 (3.1)</b>
Nissan micra	0	2 (1.3)	2 (1.2)	0	0	0	0	<b>4 (.5)</b>
Hyundai I 20	18 (9.3)	10 (6.6)	5 (2.9)	11 (6.0)	3 (3.8)	3 (6.0)	0	<b>50 (6.0)</b>
Renault Kwid	6 (3.1)	6 (4.0)	2 (1.2)	11 (6.0)	0	0	1 (8.3)	<b>26 (3.1)</b>
Renault Triber	9 (4.7)	7 (4.6)	14 (8.2)	6 (3.3)	6 (7.7)	2 (4.0)	0	<b>44 (5.3)</b>
Maruti Brezza	9 (4.7)	7 (4.6)	14 (8.2)	6 (3.3)	6 (7.7)	2 (4.0)	0	<b>44 (5.3)</b>
Maruti Baleno	20 (10.4)	9 (6.0)	27 (15.9)	26 (14.2)	13 (16.7)	8 (16.0)	2 (16.7)	<b>105 (12.5)</b>
Any other	38 (19.7)	26 (17.2)	31 (18.2)	39 (21.3)	13 (16.7)	10 (20.0)	0	<b>157 (18.8)</b>
<b>Total</b>	<b>193 (100.0)</b>	<b>151 (100.0)</b>	<b>170 (100.0)</b>	<b>183 (100.0)</b>	<b>78 (100.0)</b>	<b>50 (100.0)</b>	<b>12 (100.0)</b>	<b>837 (100.0)</b>
<b>Chi-square value</b>	<b>76.00, df = 60, Table Value = 79.1</b>							

xiv. Nature of Family and Brand Preferences of Car

Bathing soap	Nature of family		Total
	Nuclear	Joint	
Renault Triber	48 (6.9)	17 (11.9)	<b>65 (7.8)</b>
Nissan Micra	18 (2.6)	14 (9.8)	<b>32 (3.8)</b>
Hyundai i10	16 (2.3)	7 (4.9)	<b>23 (2.7)</b>
Maruti Baleno	103 (14.8)	8 (5.6)	<b>111 (13.3)</b>
Hyundai i 20	73 (10.5)	31 (21.7)	<b>104 (12.4)</b>
Renault Triber	13 (1.9)	-	<b>13 (1.6)</b>
Hyundai Creta	118 (17.0)	7 (4.9)	<b>125 (14.9)</b>
Tata Tigor	29 (4.2)	18 (12.6)	<b>47 (5.6)</b>
Honda Jazz	35 (5.0)	5 (3.5)	<b>40 (4.8)</b>
Maruti Brezza	114 (16.4)	4 (2.8)	<b>118 (14.1)</b>
Any other	127 (18.3)	32 (22.4)	<b>159 (19.0)</b>
<b>Total</b>	<b>694 (100.0)</b>	<b>143 (100.0)</b>	<b>837 (100.0)</b>
<b>Chi-square value</b>	<b>88.76**, df = 10, Table Value = 23.2</b>		



Income and Product attributes of select FMCG products

Car	income (in Rs)	N	Mean	Std. Devi.	Std. Error	f-value	p-value
<b>Hatchback</b>	Below 10000	129	42.11	6.676	0.587	3.674*	0.012
	10001-25000	144	40.33	7.621	0.635		
	25001-50000	217	41.22	9.580	0.650		
	Above 50001	347	39.48	8.887	0.477		
	Total	837	40.48	8.610	0.297		
<b>Sedan</b>	Below 10000	129	43.04	6.124	0.539	14.579**	0.000
	10001-25000	144	45.36	6.759	0.563		
	25001-50000	217	44.41	8.297	0.563		
	Above 50001	347	40.38	10.893	0.584		
	Total	837	42.69	9.202	0.318		
<b>Manual</b>	Below 10000	129	38.13	7.351	0.647	3.259*	0.021
	10001-25000	144	39.79	7.002	0.583		
	25001-50000	217	37.12	9.108	0.618		
	Above 50001	347	37.25	10.063	0.540		
	Total	837	37.79	8.997	0.310		
<b>Automatic</b>	Below 10000	129	39.52	7.267	0.639	12.935**	0.000
	10001-25000	144	41.59	4.976	0.414		
	25001-50000	217	40.31	7.300	0.495		
	Above 50001	347	36.83	11.108	0.596		
	Total	837	38.96	8.986	0.310		
<b>SUZ</b>	Below 10000	129	18.68	4.703	0.414	12.850**	0.000
	10001-25000	144	20.18	3.841	0.320		
	25001-50000	217	19.82	3.444	0.233		
	Above 50001	347	17.76	5.773	0.309		
	Total	837	18.85	4.881	0.168		

xv. Occupation and Product attributes of select FMCG products

Car	Occupation	N	Mean	Std. Devi.	Std. Error	f-value	p-value
<b>Hatchback</b>	Government employee	193	40.62	8.409	0.605	0.377	0.894
	Industrialist	151	40.84	9.071	0.738		
	Private employee	170	40.25	8.262	0.633		
	Self-employed	183	40.66	8.231	0.608		
	Professional	78	40.62	9.523	1.078		
	Agriculture	50	39.40	9.802	1.386		
	Others	12	38.08	5.468	1.578		
	Total	837	40.48	8.610	0.297		
<b>Sedan</b>	Government employee	193	42.51	8.862	0.637	0.444	0.850
	Industrialist	151	43.03	9.237	0.751		
	Private employee	170	42.24	9.476	0.726		
	Self-employed	183	42.52	8.462	0.625		
	Professional	78	44.10	9.746	1.103		
	Agriculture	50	42.54	11.546	1.632		
	Others	12	41.91	7.597	2.193		
	Total	837	42.69	9.202	0.318		
<b>Manual</b>	Government employee	193	37.34	8.663	0.623	0.168	0.985
	Industrialist	151	38.23	8.883	0.722		
	Private employee	170	37.98	9.298	0.713		
	Self-employed	183	37.65	8.871	0.655		
	Professional	78	38.00	9.426	1.067		
	Agriculture	50	37.78	10.214	1.444		
	Others	12	37.83	6.407	1.849		





	Total	837	37.79	8.997	0.310		
Automatic	Government employee	193	38.46	8.980	0.646	0.340	0.916
	Industrialist	151	39.26	9.013	0.733		
	Private employee	170	38.58	9.312	0.714		
	Self-employed	183	39.31	8.599	0.635		
	Professional	78	39.75	8.703	0.985		
	Agriculture	50	38.70	10.544	1.491		
	Others	12	39.58	5.053	1.458		
	Total	837	38.96	8.986	0.310		
SUV	Government employee	193	18.44	4.820	0.346	0.726	0.628
	Industrialist	151	19.03	4.951	0.402		
	Private employee	170	19.01	5.018	0.384		
	Self-employed	183	19.03	4.803	0.355		
	Professional	78	19.19	4.693	0.531		
	Agriculture	50	18.64	5.216	0.737		
	Others	12	16.91	4.144	1.196		
	Total	837	18.85	4.881	0.168		

Null Hypothesis:  $H_0$  There is no significant difference between Income and Product attributes of select Cars.

xvi. Total Variance Explanation

Comp onent	Initial latent value			Extraction Sums of tetragonal Loadings			Rotation Sums of tetragonal Loadings		
	Total	% of Variance	Cumulative %	Total	% of Variance	Cumulative %	Total	% of Variance	Cumulative %
1	5.995	42.821	42.821	5.995	42.821	42.821	3.024	21.600	21.600
2	1.772	12.658	55.479	1.772	12.658	55.479	2.623	18.736	40.336
3	1.175	8.392	63.872	1.175	8.392	63.872	1.904	13.601	53.937
4	0.907	6.480	70.352	0.907	6.480	70.352	1.893	13.520	67.456
5	0.778	5.558	75.909	0.778	5.558	75.909	1.183	8.453	75.909
6	0.614	4.382	80.292						
7	0.588	4.199	84.491						
8	0.477	3.406	87.897						
9	0.434	3.097	90.994						
10	0.398	2.842	93.836						
11	0.287	2.050	95.886						
12	0.228	1.630	97.515						
13	0.194	1.388	98.904						

Extraction Method: Principal Component Analysis.

## 5 MAJOR FINDINGS

- The study revealed that Maruti is the most popular Cars brand and it has the highest percentage of consumers who prefer the brand, followed by Hyundai and Renault.
- It has been depicted that Maruti enjoys more loyalty among respondents as its overall consumption is high, i.e., 64 %, as compared to other brands.
- The study revealed a significant difference between demographic variables (age, gender, education, income, occupation, family size, and nature of family) and brand preferences of Hatchback, Sedan, Manual, Automatic, and SUV.
- It has been observed that there is no meaningful relationship between occupation and brand preferences of cars.
- It has been observed that gender, education, income, family size, and family nature are associated with the sources of media through which they have come to know about Cars.
- It was depicted that most of the respondents felt that promotional offers influence the buying of the Car.



- It has been shown that product availability, product range are the factors influencing brand decisions while purchasing the Car, followed by discounts, reviews of other customers, endorsed by celebrity/famous personalities, and Car recommended by the Dealer.
- It has been revealed that the majority of the respondents felt that price is an essential factor which they consider while purchasing the Car.
- The study showed that the majority of the respondents agree that car quality is regarded as an essential factor while buying brands.
- It has been depicted that the consumers of cars strongly agreed that attributes they would consider while buying the Car are color, Range, Mileage, speed, etc.,
- Most of the respondents prefer branded products and felt that the product's price and quality are given the highest priority. It is also found that there is a shift from using not-so-popular brands to popular brands, and thus branding is gaining importance.

#### 6 Suggestions:

- The manufacturers should establish their brands and penetrate all markets to come through the implementation of effective marketing strategies.
- Rural markets are growing in India with diminishing differences between rural and urban India. With the rise in literacy levels and increasing disposable income, the demand for cars is rising. The companies' responsibility is to properly service all the retailers through proper supplies of all its vehicles and provide the critical support system.
- Consumers in rural and urban areas are more inclined towards the quality of the cars which they purchase. Therefore, it is recommended that manufacturers take care of the entire process to produce a good quality product to retain its image in the long term.

#### 7 CONCLUSION

Car production increased in various capacities by market observations, which tend to prepare for new car segment models. Many buying behaviors reference groups influenced the purchase of the cars by a cycle of decision making. The automobile industry was supported with the latest technologies, skilled workforce, excellent direct and indirect investment, and significant growth in the Indian Car consumer market. 1991, 2009, 2011, 2013, 2018, 2020 are critical years in the Indian car market and industry-wise by growing or decreasing due to various direct and indirect factors that influenced the Indian Car market and consumer. The research concludes that consumer awareness about cars has increased, and they can make decisions about which brand to buy and what type of promotions are available in various categories. They make planned purchases of quality cars that are branded from renowned brands. They can collect full information about the Car through television advertisements and shift to other vehicles if not satisfied.

#### REFERENCES

1. Srivastava MK, Tiwari AK. A Study of Behavior of Maruti SX4 and Honda City Customers in Jaipur. *Pacific Business Review-Quarterly Referred Journal*. 2013.
2. Pandya, H. P. (May 2013). *Fundamental Analysis of Indian Automobile Industry*. *International Journal of Current Research*, vol. 5, Issue 5 pg 1273 - 1286.
3. Modi S, Jhulka T. Consumer buying behavior: Changing shopping patterns. *Int. J. Bus. Manag. Eco. Res.* 2012;3(3):527-530.
4. Very Vijay Bhasker (2013) *Indian Auto Component Industry: A Decade of Growth and Way Forward*, *Research Journal of Management Sciences*, Vol. 2(3), 19-27, March (2013)
5. Malhotra G, Nandi A, Mukherjee A. Empirical research on consumer behavior towards small car segment in Indian Market. *Business Perspectives and Research*. 2012;1(1):37-46.
6. Cotterill, Ronald W., William P. Putsis Jr. and Ravi Dhar (2000), "Assessing the Competitive Interaction between Private Labels and National Brands," *Journal of Business* (73): 109-137.
7. Nataraj S, Nagaraja N. Customer satisfaction in the automobile industry—an Indian online buyers' perspective of car manufacturers' websites. *International Journal of Multidisciplinary Research*. 2012;2(6):92-107.
8. Jan.R (2013), A Study Of Brand Consciousness and Loyalty (FMCG), *International Journal Of Contemporary Practices*, Vol no 5, Issue 11, Pg no 8-26.
9. Dhole, P. (June 2013). *Analytical Study of Four Automobile Sector Companies in Price Movement of Shares*. *International Journal of Application or Innovation in Engineering & Management*, Volume 2, Issue 6, ISSN 2319-4847.
10. Boylaud, Olivier and Giuseppe Nicoletti (2001), "Regulatory Reform in Retail Distribution," *OECD Economic Studies* (32): 254-273. Aurelija Ulbinaite,(2011), "Conceptualising and Simulating Insurance Consumer Behaviour: an Agent-Based-Model Approach" *International Journal of Modeling and Optimization*, Vol. 1, No. 3,



pp.250-256. Steiner, Robert L. (2004), "The Nature and Benefits of National Brand/Private Label Competition," *Review of Industrial Organization* (24): 105-127.

11. M.Prasanna Mohan Raj, Jishnu Sasikumar, S.Sriram, A Study of Customers Brand Preference in SUVs and MUVS: Effect on Marketing Mix Variables, *International Referred Research Journal Vol. - IV, Issue-1*, pp. 48-58, Jan 2013.

12. Samin Rezvani, Goodarz Javadian Dehkordi, Muhammad Sabbir Rahman, A Conceptual study on the country of origin effect on consumer purchase intention, *Asian Social Science Vol. 8, No.12, 2012* pp. 205-215.



# ACT EAST POLICY: A MEANS FOR SUSTAINABLE DEVELOPMENT IN NORTH EAST INDIA

**Dr. Seram Bhogendra Singh**

*Head, Department of Sociology, S. Kula Women's College, Nambol, Manipur*

## ABSTRACT

India's ambitious 'Act East' policy for the sustainable development of its North-eastern region by building and enhancing trade and commerce, social entrepreneurship, cultural interaction and other links with Southeast Asia depends on successful development policies in the eight crucial north-eastern states including Manipur which has a major artery and gateway from Moreh on the international border with Myanmar leading into Southeast Asia. Under the leadership of Prime Minister Narendra Modi the new government of India has made its relations with East Asian neighbours a foreign policy priority at a time when the United States has engaged in a "pivot to Asia". The Indian Foreign Minister Sushma Swaraj proposed a new outlook calling it **Act East policy**, following on from the Look East policy which was introduced during the government of Prime Minister P.V. Narasimha Rao and seriously implemented during the following administrations of Atal Bihari Vajpayee and Manmohan Singh. India's **Look East policy** is an effort to cultivate extensive economic and strategic relations with the nations of Southeast Asia in order to bolster its standing as a regional power and a counterweight to the strategic influence of the People's Republic of China. Initiated in 1991, it marked a strategic shift in India's perspective of the world. Sustainable development is maintaining a delicate balance between the human need to improve lifestyles and feeling of well-being on one hand, and preserving natural resources and ecosystems, on which we and future generations depend. The idea of **limitations** imposed by the state of development technology and social organization on the environment's ability to meet present and future needs. Methodology: focus group discussion with government officials, and Leaders of different communities and Collection and review of literatures of published and unpublished materials regarding the present issues.

**KEY WORDS:** AEP, sustainable development, social entrepreneurship, etc.

## 1. OBJECTIVES

- i. To study Act East Policy with a positive response,
- ii. To analyse Act East Policy and its processes in relation to sustainable development in the near future,
- iii. To probe into innovation of social entrepreneurship, Sustainability, and Act East Policy in the social development of north east India.

## 2. METHODOLOGY

The present study is based on empirical study, focus group discussion with government officials, and Leaders of different communities and Collection and review of literatures of published and unpublished materials regarding the present issues.

## 3. INTRODUCTION

Act East Policy is the most successful Foreign Policy initiative started by India in the recent past. There are many definitions of 'sustainable development', but what is most frequently quoted is that formulated by the Brundtland Commission in

1987. According to this definition, sustainable development" is that pattern of development which "meets the needs of the present without compromising the ability of the future generations to meet their own needs." In addition to emphasizing the intergenerational (and intergenerational) equity, this broad definition also covered two other key concepts. The first is the concept of "needs", especially the needs of the world's poor which are seen to have overriding priority. The second concept is the idea of "limits" on the ability of the environment to meet the present and future needs. The Brundtland Commission also saw sustainable development as a process of change rather than a fixed state of harmony.

In this regard, we should always take care about the developmental processes that any kind of developmental process should not disturb the environment. For example, if we took up a project on Hydro power project or dam or multi-purposed project, we should not compromise the environment degradation so that we should keep in mind the idea of sustainable development. In short, we should utilise our natural resources in a sustainable way.



Social entrepreneurs drive social innovation and transformation in various fields including education, health, environment and enterprise development. They pursue poverty alleviation goals with entrepreneurial zeal, business methods and the courage to innovate and overcome traditional practices. A social entrepreneur, similar to a business entrepreneur, builds strong and sustainable organizations, which are either set up as not-for-profits or companies.

A social entrepreneur is a leader or pragmatic visionary who:

- i) Achieves large scale, systemic and sustainable social change through a new invention, a different approach, a more rigorous application of known technologies or strategies, or a combination of these.
- ii) Focuses first and foremost on the social and/or ecological value creation and tries to optimize the financial value creation.
- iii) Innovates by finding a new product, a new service, or a new approach to a social problem.
- iv) Continuously refines and adapts approach in response to feedback.

#### 4. ACT EAST POLICY AND ASEAN COUNTRIES

India's Act East Policy and the policies of countries like Japan and Australia are balancing the increasing influence of China in the Southeast Asian region; US lawmakers have been informed by a think-tank expert. "As China continues to invest in its military and lay down new hulls at breakneck speed, claimants have sought assistance from other partners in the region. In 2014-2015, they have begun to find it in Japan, Australia, and India," said Mira Rapp-Hooper Director, Asia Maritime Transparency Initiative Centre for Strategic and International Studies (CSIS). During a Congressional hearing yesterday, Rapp-Hooper said India has begun to implement the 'Act East Policy' to bolster its ties with the region.

At the 2014 India-ASEAN and East Asia summits, Indian officials emphasised freedom of navigation, peaceful resolution of disputes, and importance of international law, she said. In September 2014, India and Vietnam issued a joint communiqué opposing threats to freedom of navigation and use of coercion in the South China Sea. In the same month and again in January 2015, Prime Minister Narendra Modi and US President Barack Obama jointly affirmed common interests in the disputed South China Sea. In June 2015, India and the US signed a defence framework that includes a pledge to increase each other's capability to secure...freedom of navigation across sea lanes of communication. In June 2015, India also sent a four-

ship naval flotilla to Malaysia, Singapore, Indonesia, and Australia, as part of a visit to the South China Sea.

**Sushma Swaraj** noted that countries in the region have also reacted to China's assertiveness through multilateral mechanisms. "Reportedly, Vietnam, India, and Japan have privately agreed to work in a trilateral format to coordinate security policies," she said. Rapp-Hooper recommended that the US establish a mechanism to coordinate partner capacity building efforts in Southeast Asia with Australia, Japan, and India, so that training and equipment support is mutually reinforcing. Sushma Swaraj tells Indian envoys to Act east and not just look east. Official sources said the meeting is a way to chart out the future roadmap and to get a clear assessment about the Indian foreign policy in the region and its potential.

HANOI: External Affairs Minister Sushma Swaraj today chaired a brain storming session of 15 Indian Heads of Mission in South East and East Asia here and directed them to Act East and not just Look East, as she discussed the foreign policy initiatives under the new BJP-led government.

The meeting deliberated on the security structure in the strategically-important region, Chinese presence and the scope of India's growth, official sources said.

The issue of the contentious South China Sea was also deliberated upon besides the US approach to the region. This is the second Heads of Mission meeting that she has called for since assuming office in May. She held a similar session with Heads of Mission from the Middle East in Delhi. Official sources said the meeting is a way to chart out the future roadmap and to get a frank assessment about the Indian foreign policy in the region and its potential. The issue of connectivity and commercial growth was also discussed besides the Indian Diaspora based in the region. "The meeting will give the Minister first-hand knowledge about the activities of Indian missions, the challenges and the future prospects in the region," External Affairs Ministry spokesperson Syed Akbaruddin said.

India is keen to boost its ties in the region especially with ASEAN. Stressing on the need for strong connectivity within ASEAN, Swaraj has said that there is a need to look at a more "functional visa regime" in the grouping.

She said the new government in India was a strong believer in a participative approach to bring together the members of the strategic community, the Industry, the experts and professionals and the youth in India and ASEAN countries to further the common agenda of development, progress and prosperity.

Indian govt launched the Look East Policy in the early 90's. It was aimed to shift India's focus from the west and neighbours to the booming South





East Asian economies. It is also intended to spur economic growth in the North East. The govt in 2014, Look East Policy was named as Act East Policy.

## 5. RE-VISIONING THE VISION FOR NORTHEAST INDIA: NER VISION 2020

Prime Minister Manmohan Singh unveiled the "Peace Progress and Prosperity in the North Eastern Region: Vision 2020" document on 2 July 2008 in New Delhi. The Prime Minister portrayed the north-eastern region as the 'land of the rising sun' and emphasized that the initiative was a "unique event in our nation building process". This comes as a logical follow up of his speech way back in 2004 at the inauguration of the India-ASEAN Car Rally when he described the north-eastern states of India as the springboard for economic integration with Southeast Asia, Southwest China and beyond. Despite 98 per cent of its boundaries being international boundaries and its tremendous economic potential, the region has largely remained isolated and hence underdeveloped.

The report, divided into two volumes, contains the vision statement, some general strategies for the region and certain specific sectoral strategies. The vision statement delineates three purposes of the document. One, to structure a grassroots-led development process; two, enhance the role of the north-eastern region in the national economy; and three, recognize the strategic importance of the region in India's foreign policy in general and the Look East Policy (LEP) in particular.

The report acknowledges the fact that lack of communication is a major hindrance in the development of the region, thereby laying special focus on connectivity issues and related infrastructure. The construction of roads and railway lines, with a view to connect the state capitals of all north-eastern states, has been given utmost priority in the report. The report recommends the creation of centres of excellence in the north-eastern states towards developing its human resource which would help integrate the region better within the current globalized processes and contexts. It highlights issues pertaining to capacity-building, people's participation in governance, creation of economic opportunities, and use of resources for the benefit of the local population.

In Volume II, the report provides a sector-specific and industry-wise strategy to be followed. The report outlines a vision for a green revolution in the region with crop-diversification, promotion of agro-based products, promotion of horticulture and floriculture, rural credit and banking, land reforms etc., given the fact that agriculture remains the primary occupation of the north-eastern states' population. The important role of Small and Medium Enterprises (SMEs) industries in reducing poverty and unemployment has

also been acknowledged with a special focus on the role of Khadi and Village Industries (KVI) in the region. The recurrent theme in the strategy is promoting "industries with value addition". The potential in the services sector, especially in tourism and hospitality sector has remained untapped and undeveloped. Additionally, the virtual non-existence of the banking sector is also a matter of concern, as it directly affects the development process. There have been concerns about lack of banking reforms in the north-eastern states affecting the development process, which the report seeks to address by bolstering the financial sector in the Northeast and provides a plan for the same.

The report identifies as its focus areas, three broad categories of infrastructure, namely, transport and communication, industry-related infrastructure, and infrastructure related to the provision of public amenities, all initiating and sustaining the growth process. Some important recommendations have been made, one of them being improved connectivity between the capital cities of the north-eastern states.

The report gives special attention to region-specific needs in the educational sector. It aims to bridge the gap between different geographical areas, in terms of health-related facilities. The report recognizes the fact that around 80 per cent of job creation is still in the agricultural and allied sectors. It plans to promote and build entrepreneurial capabilities and provide vocational education to diversify the employment opportunities.

The role of local government institutions in the planning process and service-delivery has been underlined in the report, envisaging a role for government agencies as enablers of developmental and productive activities, and forging a closer partnership between local bodies and government agencies.

Significant investments in social and physical infrastructure are needed to achieve the goal of 'peace and prosperity' in the region. Each central government department earmarks 10 per cent of its planned budget for the north-eastern region, which needs concrete policies and projects to back up and account for. In order to ensure increased private investment in the region, a secure environment, coupled with improved physical infrastructure and skilled manpower will be needed.

The report devotes a full chapter to India's LEP in the NER perspective. It highlights the fact that the 'Look East Policy must begin with the NER'. The cultural connection between the north-eastern states and the neighbouring countries provides a substantial basis for people-to-people contacts, which would lead to economic development of the region through the strengthening of commercial links with its proximate international neighbourhood.



The full impact of the report needs to be assessed in terms of the political will to initiate its recommendations by the concerned Central government ministries and the state governments. Critical to its success would be concrete policies to back up the funds allocated, accompanied by much needed coordination and unity among the north-eastern states governments.

## REFERENCES

1. Thongkhohal Haokip, "India's Look East Policy: Its Evolution and Approach," *South Asian Survey*, Vol. 18, No. 2 (September 2011), pp. 239-257.
2. Myanmar shows India the road to Southeast Asia
3. India's "Look East" Policy Pays Off
4. Sino-Myanmar Relations: Analysis and Prospects by Lixin Geng, *The Culture Mandala*, Vol. 7, no. 2, December 2006
5. Shambaugh, David (2006). *Power Shift: China and Asia's New Dynamics*. University of California Press. p. 218. ISBN 978-0-520-24570-9.
6. David Brewster. "India as an Asia Pacific Power. Retrieved 19 August 2014".
7. "Explaining India's silence over Burma". *BBC News*. 26 September 2007. Retrieved 11 May 2010.
8. *India and China compete for Burma's resources* Available on the website <https://www.worldpoliticsreview.com/articles/129/india-and-china-compete-for-burmas-resources> access on 29/05/2021
9. Walter C. Ladwig III, "Delhi's Pacific Ambition: Naval Power, 'Look East,' and India's Emerging Role in the Asia-Pacific," *Asian Security*, Vol. 5, No. 2 (June 2009), pp. 98–101.
10. "Modi govt to give greater push to India's Look East Policy, says Sushma Swaraj". *Firstpost*. 2014-08-25. Retrieved 2014-09-10.
11. "Sushma Swaraj tells Indian envoys to Act East and not just Look East". *The Economic Times*. 26 August 2014.
12. **PTI Updated:** Aug 26, 2014, 03.27 PM IST
13. Available on website <http://economictimes.indiatimes.com/news/politics-and-nation/sushma-swaraj-tells-indian-envoys-to-act-east-and-not-just-look-east/articleshow/40907671.cmsinttarget> access on 3/5/2021



# A COMPARATIVE STUDY OF EFFECTIVENESS OF ELEARNING DURING COVID 19: EVIDENCE FROM ERNAKULAM AND IDUKKI DISTRICTS OF KERALA

Anusree V Nair<sup>1</sup>, Siby K M<sup>\*2</sup>

<sup>1</sup>Postgraduate Scholar, Postgraduate Department of Economics, Govt.College Munnar, Kerala, India

<sup>2</sup>Assistant Professor, Postgraduate department of Economics, St.Paul's College Kalamassery, Kerala, India

\*Corresponding Author: Siby K M

## ABSTRACT

*The testing times of Covid Pandemic had forced upon students eLearning without getting any sort of preparations. Though inevitable, the onslaught of eLearning into hitherto undeterred lives of students made profound impacts in varying magnitudes. The present study aimed to analyze a spatial comparison of the effectiveness of eLearning among students based on data collected from 100 student respondents belonging to the Ernakulam and Idukki districts of Kerala. The frequency analysis and Chi-Square analysis were applied to study the data and found that there was a significant difference in the preference for the device of eLearning and the problems faced in accessing online classes among students between these two districts.*

**KEYWORDS:** eLearning, Student Preferences, Chi-Square

## 1. INTRODUCTION

The world witnessed unprecedented closing down of universities and educational institutes globally due to the Covid pandemic. Nobody was prepared for such a game-changing transition causing hiccups and adjustment lags in the teaching-learning process. (Siby K M, 2021) The availability and accessibility of several online platforms made this transition somewhat painless. The student's readiness towards the adoption of online learning is still lurking in the dark. (Neupane et al., 2020) In this context, the present study intends to make a spatial analysis of the effectiveness of eLearning among graduate and postgraduate students between the Ernakulam and Idukki districts of Kerala.

The present study is structured in the following ways. Section two delineates the objectives and hypotheses of the study. Section three briefly depicts the methodologies used in the study. Section four gives a brief review of the literature. Section five elaborates the results and its discussions. Section six summarizes the important findings of the study.

## 2. OBJECTIVES AND HYPOTHESES

The primary objective of the study was to make a comparative analysis of the effectiveness of eLearning among students between the Ernakulam and Idukki districts of Kerala. The following hypotheses were formulated for meeting these objectives.

H<sub>01</sub>: There is no significant difference in the interest of students in eLearning between the Ernakulam and Idukki districts of Kerala.

H<sub>02</sub>: There is no significant difference in the preference of device for eLearning by students between Ernakulam and Idukki districts of Kerala.



H<sub>03</sub>: There is no significant difference in the preference of app for eLearning by students between Ernakulam and Idukki districts of Kerala.

H<sub>04</sub>: There is no significant difference in the satisfaction levels of students for eLearning between Ernakulam and Idukki districts of Kerala.

H<sub>05</sub>: There is no significant difference in the issues faced by students in eLearning between the Ernakulam and Idukki districts of Kerala.

H<sub>06</sub>: There is no significant difference in the offline/online class preference of students between the Ernakulam and Idukki districts of Kerala.

H<sub>07</sub>: There is no significant difference in the preference of class methodology of students between Ernakulam and Idukki districts of Kerala.

H<sub>08</sub>: There is no significant difference in the problems in accessing online classes among students between Ernakulam and Idukki districts of Kerala.

### 3. RESEARCH METHODOLOGY

The sample of the study was composed of 100 students of which 50 students belonged to Ernakulam district and the other 50 students were from the Idukki district of Kerala. A well-structured questionnaire was constructed and data were collected online to ensure that all respondents had Internet facilities. The study also made use of frequency analysis and chi-square analysis to find out the effectiveness of eLearning among students of Ernakulam and Idukki districts.

### 4. REVIEW OF LITERATURE

Mridul Bisht et al., in their study, analyzed the impact of Covid 19 on the mental health of students. The researcher concluded that the majority of students experienced moderate Depression 27(16.98%), Anxiety 27 (16.98%), and stress 23 (14.46%) due to online classes (Mridul et al., 2021). Dr. Varun V Varghese and Siby KM analyzed the attitude of students towards Internet and online classes and found that gender and age categories had no significant association with time spent on online classes while the education category of students shows a significant association (Siby K M, 2021). Joseph Paschal M. Mkulu D. G. in their study of online classed during Covid 19 concluded that students learned more in less time and liked their classes more when ICT-based instruction was included (Joseph Paschal & Mkulu, 2020)

### 5. RESULTS AND DISCUSSION

This section is classified into segments

- 1) Demographic Profile of the respondents
- 2) District wise Characteristics of eLearning among students
- 3) Chi-square analysis

#### 5.1) DEMOGRAPHIC PROFILE

Variable	Characteristics	Frequency	Percentage
Gender	Male	38	38
	Female	62	62
Age	Age 17-20	7	7
	Between 20 and 23	61	61
	Between 23 and 26	32	32
Religion	Hindu	44	44
	Christian	50	50
	Muslim	4	4
	Others	2	2
Caste	General	51	51
	OBC	37	37
	OEC	2	2



	SC/ST	7	7
	Others	3	3
Residential Region	Rural	78	78
	Urban	22	22
Parental Education	Below SSLC	23	23
	Plus Two/ITI/Polytechnic	48	48
	Graduation	21	21
	Post Graduation	8	8
Annual Income	Below 50000	54	54
	50000-200000	32	32
	200000-500000	10	10
	Above 500000	4	4

## 5.2) District wise Characteristics of eLearning among students

### 5.2.1 District wise interest in eLearning among students

<b>Table 2: District wise interest in eLearning among students</b>			
<b>District</b>		<b>Frequency</b>	<b>Percent</b>
1 Ernakulam	1 Yes	26	52.0
	2 No	10	20.0
	3 Maybe	14	28.0
	Total	50	100.0
2 Idukki	1 Yes	29	58.0
	2 No	7	14.0
	3 Maybe	14	28.0
	Total	50	100.0

### 5.2.2 District wise preference of device for eLearning among students

<b>Table 3: District wise preference of device for eLearning among students</b>			
<b>District</b>		<b>Frequency</b>	<b>Percent</b>
1 Ernakulam	1 Mobile	33	66.0
	2 Laptop	17	34.0
	Total	50	100.0
2 Idukki	1 Mobile	44	88.0
	2 Laptop	6	12.0
	Total	50	100.0

### 5.2.3 District wise preference of apps for eLearning among students

<b>Table 4: District wise preference of apps for eLearning among students</b>			
<b>District</b>		<b>Frequency</b>	<b>Percent</b>
1 Ernakulam	1 Zoom	9	18.0
	2 Google meet	24	48.0
	3 Whatsapp	9	18.0
	4 YouTube	8	16.0
	Total	50	100.0
2 Idukki	1 Zoom	9	18.0
	2 Google meet	22	44.0
	3 Whatsapp	11	22.0
	4 YouTube	7	14.0





	5 Mail	1	2.0
	Total	50	100.0

#### 5.2.4 District wise preference of offline and online class among students

District		Frequency	Percent
1 Ernakulam	1 Classroom	41	82.0
	2 eLearning	9	18.0
	Total	50	100.0
2 Idukki	1 Classroom	46	92.0
	2 eLearning	4	8.0
	Total	50	100.0

#### 5.2.5 District wise preference of teaching methodology among students

District		Frequency	Percent
1 Ernakulam	1 Google classroom	8	16.0
	2 Blackboard	42	84.0
	Total	50	100.0
2 Idukki	1 Google classroom	11	22.0
	2 Blackboard	39	78.0
	Total	50	100.0

### 5.3) Chi-square Analysis

#### 5.3.1) Testing of the first Hypothesis

Null Hypothesis: There is no significant difference in the interest of students in eLearning between the Ernakulam and Idukki districts of Kerala.

Alternative Hypothesis: There is a significant difference in the interest of students in eLearning between the Ernakulam and Idukki districts of Kerala.

Table 7: District \* Interest in eLearning Cross tabulation

			Interest in eLearning			Total
			1 Yes	2 No	3 Maybe	
District	1 Ernakulam	Count	26	10	14	50
		Expected Count	27.5	8.5	14.0	50.0
		% Within District	52.0%	20.0%	28.0%	100.0%
	2 Idukki	Count	29	7	14	50
		Expected Count	27.5	8.5	14.0	50.0
		% Within District	58.0%	14.0%	28.0%	100.0%
Total	Count	55	17	28	100	
	Expected Count	55.0	17.0	28.0	100.0	
	% within District	55.0%	17.0%	28.0%	100.0%	

Table 8: Chi-Square Tests

	Value	df	Asymp. Sig. (2-sided)
Pearson Chi-Square	.693 <sup>a</sup>	2	.707

a. 0 cells (0.0%) have expected count less than 5. The minimum expected count is 8.50.



From the resulting output, it is evident that there is no significant difference in the interest of students in eLearning between Ernakulam and Idukki districts of Kerala, Pearson chi-square (2, N=100) = .693,  $p = 0.707$ .

Students in the districts of Ernakulam and Idukki show no significant difference in the interest of eLearning. They have similar patterns of interest in eLearning. 52% of students from Ernakulam district and 58% of students from Idukki district show interest in eLearning. The assumptions of the chi-square test are not violated since zero cells have an expected count of less than 5

### 5.3.2) Testing of the second hypothesis

Null Hypothesis: There is no significant difference in the preference of device for eLearning by students between Ernakulam and Idukki districts of Kerala.

Alternative Hypothesis: There is a significant difference in the preference of device for eLearning by students between Ernakulam and Idukki districts of Kerala.

**Table 9: District \* The preference of device for eLearning Cross tabulation**

			The preference of device for eLearning		Total
			1 Mobile	2 Laptop	
District	1 Ernakulam	Count	33	17	50
		Expected Count	38.5	11.5	50.0
		% within District	66.0%	34.0%	100.0%
	2 Idukki	Count	44	6	50
		Expected Count	38.5	11.5	50.0
		% within District	88.0%	12.0%	100.0%
Total	Count	77	23	100	
	Expected Count	77.0	23.0	100.0	
	% within District	77.0%	23.0%	100.0%	

Table 10: Chi-Square Tests

	Value	df	Asymp. Sig. (2-sided)	Exact Sig. (2-sided)	Exact Sig. (1-sided)
Pearson Chi-Square	6.832 <sup>a</sup>	1	.009		

a. 0 cells (0.0%) have expected count less than 5. The minimum expected count is 11.50.

b. Computed only for a 2x2 table

From the resulting output, it is evident that there is a significant difference in the preference of device for eLearning by students between Ernakulam and Idukki districts of Kerala, Pearson chi-square (1, N=100) = 6.832,  $p = 0.009$ .

Students in the districts of Ernakulam and Idukki show a significant difference in their preference of device for eLearning. In Ernakulam district, only 66% of students preferred mobile for eLearning whereas, in Idukki district, it went up to 88%. The assumptions of the chi-square test are not violated since zero cells have an expected count less than 10 (2x2 table).

### 5.3.3) Testing of the third hypothesis

Null Hypothesis: There is no significant difference in the preference of app for eLearning by students between Ernakulam and Idukki districts of Kerala.

Alternative Hypothesis: There is a significant difference in the preference of app for eLearning by students between Ernakulam and Idukki districts of Kerala.



**Table 11: District \* Preference of app for eLearning Cross tabulation**

		Preference of app for eLearning					Total	
		1 Zoom	2 Google meet	3 Whatsapp	4 YouTube	5 Mail		
District	1 Ernakulam	Count	9	24	9	8	0	50
		Expected Count	9.0	23.0	10.0	7.5	.5	50.0
		% within District	18.0%	48.0%	18.0%	16.0%	0.0%	100.0%
	2 Idukki	Count	9	22	11	7	1	50
		Expected Count	9.0	23.0	10.0	7.5	.5	50.0
		% within District	18.0%	44.0%	22.0%	14.0%	2.0%	100.0%
Total	Count	18	46	20	15	1	100	
	Expected Count	18.0	46.0	20.0	15.0	1.0	100.0	
	% within District	18.0%	46.0%	20.0%	15.0%	1.0%	100.0%	

**Table 12: Chi-Square Tests**

	Value	df	Asymp. Sig. (2-sided)
Pearson Chi-Square	1.354 <sup>a</sup>	4	.852

a. 2 cells (20.0%) have expected count less than 5. The minimum expected count is .50.

From the resulting output, it is evident that there is no significant difference in the preference of app for eLearning by students between Ernakulam and Idukki districts of Kerala, Pearson chi-square (1, N=100) = 1.354,  $p = .852$  48% of students in Ernakulam district prefer Google meet of eLearning in comparison to 44% of students in Idukki district. The assumptions of the chi-square test are not violated since zero cells have an expected count of less than 5.

#### 5.3.4) Testing of the fourth hypothesis

Null Hypothesis: There is no significant difference in the satisfaction levels of students for eLearning between Ernakulam and Idukki districts of Kerala.

Alternative Hypothesis: There is a significant difference in the satisfaction levels of students for eLearning between the Ernakulam and Idukki districts of Kerala.

**Table 13: District \* Satisfaction with eLearning Cross tabulation**

			Satisfaction with eLearning			Total
			1 Yes	2 No	3 Maybe	
District	1 Ernakulam	Count	18	14	18	50
		Expected Count	15.5	16.5	18.0	50.0
		% within District	36.0%	28.0%	36.0%	100.0%
	2 Idukki	Count	13	19	18	50
		Expected Count	15.5	16.5	18.0	50.0
		% within District	26.0%	38.0%	36.0%	100.0%
Total	Count	31	33	36	100	
	Expected Count	31.0	33.0	36.0	100.0	
	% within District	31.0%	33.0%	36.0%	100.0%	

**Table 14: Chi-Square Tests**

	Value	df	Asymp. Sig. (2-sided)
Pearson Chi-Square	1.564 <sup>a</sup>	2	.457

a. 0 cells (0.0%) have expected count less than 5. The minimum expected count is 15.50.

From the resulting output, it is evident that there is no significant difference in the satisfaction levels of students for eLearning between Ernakulam and Idukki, Pearson chi-square (1, N=100) = 1.564,  $p = .457$

64% of students in Ernakulam district have no satisfaction or indeterminate regarding satisfaction in eLearning in comparison to 74% of students in the Idukki district. The assumptions of the chi-square test are not violated since zero cells have an expected count of less than 5.

### 5.3.5) Testing of the fifth hypothesis

Null Hypothesis: There is no significant difference in the issues faced by students in eLearning between Ernakulam and Idukki districts of Kerala.

Alternative Hypothesis: There is a significant difference in the issues faced by students in eLearning between the Ernakulam and Idukki districts of Kerala.

**Table 15: District \* issues during eLearning Cross tabulation**

			Issues during eLearning			Total
			1 Yes	2 No	3 Maybe	
District	1 Ernakulam	Count	20	10	20	50
		Expected Count	25.5	7.5	17.0	50.0
		% within District	40.0%	20.0%	40.0%	100.0%
	2 Idukki	Count	31	5	14	50
		Expected Count	25.5	7.5	17.0	50.0
		% within District	62.0%	10.0%	28.0%	100.0%
Total	Count	51	15	34	100	
	Expected Count	51.0	15.0	34.0	100.0	
	% within District	51.0%	15.0%	34.0%	100.0%	

**Table 16: Chi-Square Tests**

	Value	df	Asymp. Sig. (2-sided)
Pearson Chi-Square	5.098 <sup>a</sup>	2	.078

a. 0 cells (0.0%) have expected count less than 5. The minimum expected count is 7.50.

From the resulting output, it is evident that there is no significant difference in the issues faced by students in eLearning between Ernakulam and Idukki districts of Kerala, Pearson chi-square (1, N=100) = 5.098,  $p = .078$ . 40% of students in Ernakulam district face issues in eLearning in comparison to 62% of students in the Idukki district. The assumptions of the chi-square test are not violated since zero cells have an expected count of less than 5.

### 5.3.6) Testing of the sixth hypothesis

Null Hypothesis: There is no significant difference in the offline/online class preference of students between the Ernakulam and Idukki districts of Kerala.

Alternative Hypothesis: There is a significant difference in the offline/online class preference of students between the Ernakulam and Idukki districts of Kerala.

**Table 17: District \* Class Preference Cross tabulation**

			Class Preference		Total
			1 Classroom	2 eLearning	
District	1 Ernakulam	Count	41	9	50
		Expected Count	43.5	6.5	50.0
		% within District	82.0%	18.0%	100.0%
	2 Idukki	Count	46	4	50
		Expected Count	43.5	6.5	50.0
		% within District	92.0%	8.0%	100.0%
Total	Count	87	13	100	
	Expected Count	87.0	13.0	100.0	
	% within District	87.0%	13.0%	100.0%	

**Table 18: Chi-Square Tests**

	Value	df	Asymp. Sig. (2-sided)	Exact Sig. (2-sided)	Exact Sig. (1-sided)
Pearson Chi-Square	2.210 <sup>a</sup>	1	.137		
Fisher's Exact Test				.234	.117

a. 0 cells (0.0%) have expected count less than 5. The minimum expected count is 6.50.

b. Computed only for a 2x2 table

From the resulting output, it is evident that there is no significant difference in the offline/online class preference of students between Ernakulam and Idukki districts of Kerala, Pearson chi-square (1, N=100) = 2.210,  $p = .137$ , Fisher's Exact Test  $p = .234$ .

82% of students in Ernakulam district prefer offline class to eLearning in comparison to 92% of students in the Idukki district. The assumptions of the chi-square test are not violated since zero cells have an expected count of less than 5.





### 5.3.7) Testing of the seventh hypothesis

Null Hypothesis: There is no significant difference in the preference of class methodology of students between Ernakulam and Idukki districts of Kerala.

Alternative Hypothesis: There is a significant difference in the preference of class methodology of students between Ernakulam and Idukki districts of Kerala.

**Table 19: District \* Effective Method to run the class Cross tabulation**

			Effective Method to run class		Total
			1 Google classroom	2 Blackboard	
District	1 Ernakulam	Count	8	42	50
		Expected Count	9.5	40.5	50.0
		% within District	16.0%	84.0%	100.0%
	2 Idukki	Count	11	39	50
		Expected Count	9.5	40.5	50.0
		% within District	22.0%	78.0%	100.0%
Total	Count	19	81	100	
	Expected Count	19.0	81.0	100.0	
	% within District	19.0%	81.0%	100.0%	

**Table 20: Chi-Square Tests**

	Value	df	Asymp. Sig. (2-sided)	Exact Sig. (2-sided)	Exact Sig. (1-sided)
Pearson Chi-Square	.585 <sup>a</sup>	1	.444		
Fisher's Exact Test				.611	.306

a. 0 cells (0.0%) have expected count less than 5. The minimum expected count is 9.50.

b. Computed only for a 2x2 table

From the resulting output, it is evident that there is no significant difference in the preference of class methodology of students between Ernakulam and Idukki districts of Kerala, Pearson chi-square (1, N=100) = .585,  $p = .444$ , Fisher's Exact Test  $p = .611$

The assumptions of the chi-square test are not violated since zero cells have an expected count of less than 5. 84% of students in Ernakulam district blackboard to Google classroom in comparison to 78% of students in Idukki district.

### 5.3.8) Testing of the Eighth hypothesis

Null Hypothesis: There is no significant difference in the problems in accessing online classes among students between Ernakulam and Idukki districts of Kerala.



Alternative Hypothesis: There is a significant difference in the problems in accessing online classes among students between Ernakulam and Idukki districts of Kerala.

**Table 21: District \* Problems in accessing online class Cross tabulation**

			Problems in accessing online class			Total
			1 Yes	2 No	3 Maybe	
District	1 Ernakulam	Count	17	17	16	50
		Expected Count	22.5	11.0	16.5	50.0
		% within District	34.0%	34.0%	32.0%	100.0%
	2 Idukki	Count	28	5	17	50
		Expected Count	22.5	11.0	16.5	50.0
		% within District	56.0%	10.0%	34.0%	100.0%
Total		Count	45	22	33	100
		Expected Count	45.0	22.0	33.0	100.0
		% within District	45.0%	22.0%	33.0%	100.0%

**Table 22: Chi-Square Tests**

	Value	df	Asymp. Sig. (2-sided)
Pearson Chi-Square	9.265 <sup>a</sup>	2	.010

a. 0 cells (0.0%) have expected count less than 5. The minimum expected count is 11.00.

From the resulting output, it is evident that there is a significant difference in the problems in accessing online classes among students between Ernakulam and Idukki districts of Kerala, Pearson chi-square (1, N=100) = 9.265, p = 0.010.

Students in the districts of Ernakulam and Idukki show a significant difference in the problems in accessing the online class. In Ernakulam district, only 34% of students face problems in accessing online classes in comparison to 56% in the Idukki district. The assumptions of the chi-square test are not violated since zero cells have an expected count of less than 5.

## 6. CONCLUSION

The predominant conclusion of the study based on the sample data analysis was that there was a significant difference in the preference for devices and the problems faced in accessing online classes among students between the two districts. On the other hand, there was no significant difference concerning interest in eLearning, preference of apps used in eLearning, satisfaction levels of students, issues faced during online classes, preference for offline/online classes, and preference for the methodology of teaching among students between Ernakulam and Idukki districts. The study found that 84% of students in Ernakulam district preferred blackboard to Google classroom in comparison to 78% of students in Idukki district. It is also found that in Ernakulam district only 66% of students preferred mobile for eLearning whereas, in Idukki district, it went up to 88%. The preference for Google meet as a platform for eLearning was 48% among students in Ernakulam district in comparison to 44% in Idukki district. From the study, it is found that students prefer eLearning only as a temporary solution in times of Covid and eager to get back to interactive sessions of classroom learning. A majority of students find that the network issues and lack of gadgets make their learning painful and counterproductive. But still, there is a segment of the students who get accustomed to this transition and believe that the future of learning is eLearning.

## REFERENCES

1. Joseph Paschal, M., & Mkulu, D. G. (2020). Online Classes during COVID-19 Pandemic in Higher Learning Institutions in Africa. *Global Research in Higher Education*, 3(3). <https://doi.org/10.22158/grhe.v3n3p1>



2. Mridul, Bisht, B., Sharma, D., & Kaur, N. (2021). *Online classes during covid-19 pandemic: Anxiety, stress & depression among university students*. *Indian Journal of Forensic Medicine and Toxicology*, 15(1). <https://doi.org/10.37506/ijfnt.v15i1.13394>
3. Neupane, H. C., Sharma, K., & Joshi, A. (2020). *Readiness for the Online Classes during COVID-19 Pandemic among Students of Chitwan Medical College*. *Journal of Nepal Health Research Council*, 18(2). <https://doi.org/10.33314/jnhrc.v18i2.2725>
4. Siby K M, D. V. V. V. (2021). *A STUDY OF INTERNET UTILIZATION BY STUDENTS IN TIMES OF COVID PANDEMIC: EVIDENCE FROM ERNAKULAM DISTRICT OF KERALA*. *EPRA International Journal of Multidisciplinary Research (IJMR)-Peer Reviewed Journal*, 7(5), 2455–3662.



## THE SOCIAL CONTENT AND VALUE OF THE PHENOMENON “FREE TIME”

**Farrux Rustamov Rustam ogli**

*Teacher, Bukhara branch of the Tashkent Institute of Irrigation and Agricultural Mechanization Engineers*

### ANNOTATION

*The article analyzes the concepts of free time, rest and relaxation as a process determined by social conditions, that relieve fatigue, restore a person's spiritual and intellectual strength. Leisure time is also cited as part of the free time used to preserve, disseminate, consume these spiritual cultural values, amateur creativity, entertainment and recreation, and other types of unregulated activities that promote further personal development.*

*The article discusses the theoretical understanding of leisure and recreation, as well as the views and approaches of thinkers on the importance of leisure, socio-historical and individual characteristics.*

**KEYWORDS:** *Leisure, rest, recreation, human resources, freedom, labor, society, personality.*

Leisure is the part of free time at the disposal of an individual, not occupied with matters of production or vital necessity, used for leisure or personal development at will.

The concept of leisure should be distinguished from the concept of rest and relaxation. Rest is a psychophysiological process determined by social conditions, which eliminates fatigue and restores a person's spiritual and intellectual strength. Leisure is the part of free time used for the preservation, dissemination, consumption of spiritual culture values, amateur creativity, entertainment and recreation, and other types of unregulated activities that ensure the further development of the individual.

Leisure culture is a personal trait that reflects the need and ability to use leisure time constructively. Leisure and recreation are not only different concepts, but also terms related to different areas of scientific knowledge. Leisure is a social, economic, educational category. Recreation is a psychophysiological category.

Everyone can manage their free time as they wish. Any activity is possible in your free time. Including creative, consumer, constructive, destructive, and more.

Leisure time forms a system of values. At the same time, a person moves from simple to more complex forms, from consumption and assimilation of culture - to creativity, from a narrow group, family activities - to a social and cultural direction. Each stage of recreation is different from the choice of recreation and activities. Most importantly, it is a

special dominant that focuses on one or another value. The first and elementary values of rest are rest and movement that serve to restore physical strength and mental balance. Without satisfying the basic need for recreation, a person cannot move to more complex forms of leisure.

After rest, a person feels a natural need for play and entertainment. Walking, traveling, chatting, reading, playing sports and indoor games, going to the movies, theater, and a variety of hobbies can be chosen as entertainment. Enlightenment is, in the broadest sense of the word, the introduction of this person into culture. Enlightenment consists of mastering the values of classical cultural heritage, first of all, science, art, philosophy. This includes getting to know the cultural life of other peoples, learning languages, and history.

The expansion of freedom, expressed in the previous three levels of leisure, the tendencies of the completeness of being, have a full scope in creativity. Creativity is the freest type of activity. Human life can be full only if there is a place for creativity, for creative activity, because it is in creation that a person realizes his potential. The next stage of relaxation is contemplation. In moments of contemplation, man accumulates experience and perfection. He understands his unity with the world, his place in it. Contemplation calms, maintains balance. There are different types of thinking, such as natural thinking, historical thinking, and self-thinking. Only well-rounded individuals can know the contemplative leisure time. A characteristic



feature of contemplation is loneliness. But a person cannot be alone for long. Loneliness can be overcome through celebration, which should be considered one of the most important elements of culture. The holiday creates a sense of community, brotherhood.

The system of leisure time values consists of the following elements: rest and movement; entertainment; education; creativeness; thinking; holiday.

The content of leisure time depends on a person's financial status, place of residence, social status, education, customs, nationality, religion, profession, government policy, health, character and temperament, age, gender, marital status and other factors.

Leisure performs the following functions: rest; communicative; development; socialization; hedonistic; compensation.

These functions are implemented in different forms of leisure. The difficulty of determining the nature of leisure is probably the same as any objective existing phenomenon. It has individuals of different order, each of which reveals one of its socially significant aspects. In particular, the essence of the first order is its ontological essence (i.e. its independent to determine its existence as an event) is the time when it is not engaged in the production of leisure time or in matters of vital necessity. In his spare time, the separation of only this aspect was considered insufficient in sociology, degrading its social value.

Proponents of this approach saw the essence of leisure in spiritually rich activities, as well as in the morally and aesthetically acceptable forms of leisure, as types of restorative activities that an individual receives after work.

At the same time, the special significance of leisure time is that it is an important condition for the free and harmonious development of the individual. That is, free time can be used as a means of physical and spiritual improvement of the individual.

Summarizing the above, we can conclude that society and a particular individual determine the ways of using free time according to their needs, interests and goals.

Explaining the nature of leisure is not only a theoretical task, but also aimed at defining its social and individual purpose, and thus its social significance.

The study of leisure time demonstrated the public's interest in it and demonstrated its practical significance in the most important areas of society and at different stages of its development.

In the literature on the problem under consideration, two main approaches to its study are unanimously distinguished:

First, the economy is viewed as part of the non-working time used for extended reproduction of leisure labor, as well as for the training of more skilled workers who meet the requirements of the period of scientific and technological progress. Because it re-enters the production process and manifests itself in a positive way in it.

Second, the sociological approach is characterized by the most in-depth study of the problem. It is characterized by a comprehensive study of the phenomenon of social time, revealing its essence, the relationship between working and non-working time, the role of free time for the life of different groups of the population, and so on.

The sociological approach examines the problem of leisure in the most meaningful and complete way. We can say that it reveals all the components of a social phenomenon. In particular, this approach explores whether the content of leisure time depends on a variety of socio-historical and individual factors, as well as objective and subjective factors.

An important role for the sociologist in the study of leisure time is to identify the main types of entertainment of people, as well as to analyze and develop mechanisms for regulating the amount of leisure time and its content specific to different segments of the population.

The issue of leisure content is particularly sensitive. Because in the field of solving it, public and private interests collide. So, for example, society tends to direct man to activities of moral and aesthetic importance, and man may have deviant interests, i.e., deviate from social interests. The resulting dispute must be resolved legally and in acceptable forms without infringing on the personal rights and freedoms of citizens.

Given the approaches available in leisure learning, two more should be noted. Socio-psychological examines, for example, individuals' attitudes toward free activity and arbitrary changes in their leisure time in the direction of its increase by reducing work or study time. However, from the point of view of these individuals, there are two types of activities. The first is the value for the individual, supported by his positive mental states, and the second is the aspects that are only external results and sometimes alien to the individual value system.

The content of this approach is to analyze the subjective relationship to the mass of possible types of activities and to determine the reasons for the preference for its specific types. Researchers in this field pay the greatest attention to the study of the content of leisure time of adolescents and young people.

The socio-psychological approach is close with a clear pedagogical inclination. Its main





direction is the study of methods, forms and means of educational interaction with the emerging person in the field of leisure. Realizing his free time, a person becomes a social subject. All the norms of a regulating nature belong to him, because in the field of free time not only his personal life, but also his social existence, interactions with other people take place.

In the sociological literature, from our point of view, the least popular and least effective approach can be distinguished. This reduces the amount of free time to the entire amount of non-working time. Indeed, representatives of this view divide a person's entire time budget into two parts: work and free time. At the same time they ignore the sign of free time as a period when the usual necessity is not loaded.

The question for everyone who works is how much work, how much rest. If he does not work, his maximum rest will be one day, that is, 24 hours, and his income will be zero. It is known that a person does not always work 24 hours a day. Naturally, a person's working hours will be limited, he will have to rest for a certain amount of time and restore his ability to work. In addition, rest provides him with spiritual growth. This means that if a person works for a certain period of time and earns a certain amount of income, he also receives some benefit when he rests for a certain period of time (spiritual growth, enjoyment). So, the question of how long a person should work and how long he should rest can be put as follows:

We write the function of quality, which depends on a person's working time and rest time, as follows:

$U = U(t, T)$ , where  $U$  - quality function;  
 $t$  - rest time;  $T$  - working hours.

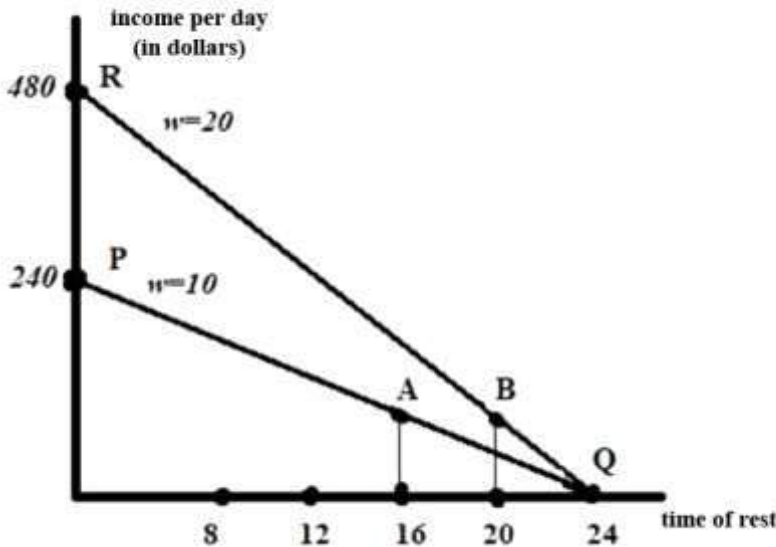
This means that the worker must divide the 24 hours a day into working hours and rest time so that he receives the maximum benefit as a result:  
 $U = U(t, T) \rightarrow \max$ .

Further increases in income will not encourage all people to reduce their leisure time and increase their working hours. The shortening of the rest time increases its value to man.

Wage growth affects the ratio between rest time and working time. The wage rate measures the value of leisure time for a person, which means that the salary reflects the amount of money a person spends on leisure time. Usually, when wages increase, many try to work harder and earn more. However, as working hours increase, so does the value of free time. Man also strives for spiritual growth. This means that the increase in working hours has its limits. After all, people spend their earned income on recreation to enjoy it more.

An increase in wages after working hours have increased to a certain point leads to a reduction in working hours. When wages increase, there is a substitution effect as well as an income effect. Higher wages as a result of substitution increase an individual's real income. When a person earns a lot, he buys more blessings, one of these blessings is a good rest.

"If a person spends more on leisure, the increase in income will encourage him to work less. When the increase in income is too large, it reduces a person's working hours and the labor supply line lies down.





This picture shows a decision on the choice of the ratio of working time and rest time. The horizontal arrow indicates the number of hours of rest per day, and the vertical arrow indicates the income generated by the work. Initially, the salary is \$ 10 per hour, the budget line is given in the form of PQ. Point P, for example, indicates that a person who works 24 hours a day earns \$ 240. A person who chooses point A will rest 16 hours a day and work 8 hours a day, earning \$ 80. When wages are transferred to \$ 20 per hour, the budget line becomes a straight-line RQ. Now a person maximizes income at point B, chooses to rest 20 hours a day and works 4 hours and earns \$ 80. The income effect outweighs the substitution effect and shortens the working day from 8 hours to 4 hours.

It appears that income growth will increase the demand for recreation. This is reflected in the reduction of working hours and the increase in leisure time. As wages rise, so does the cost of vacations.”[9]

Typically, in developed countries, as the average income of the population is much higher, they tend to rest more. Because wages are low in developing countries, wage growth encourages workers to work longer hours and earn more.

As a result of market economy relations and scientific and technological progress, labor processes are constantly becoming more complex. This, in turn, requires the intellectual development of young people, the improvement of their profession, knowledge and skills, the satisfaction of their spiritual needs, the effective organization of leisure. The solution of these problems depends on the improvement of educational work, proper organization of work, good organization of leisure. Because study, work and leisure are interrelated. The education and upbringing of young people, the organization of their leisure and cultural recreation is an important social event of state importance.

Nowadays, the rational organization of people's leisure time, its proper organization is also an urgent task for cultural and educational institutions. Therefore, it is expedient to consider the work in this area on the basis of the requirements of the time, to think about their methods and forms of work, to generalize practical experience.

## REFERENCES

1. Batueva, B.B. *Free time and culture of leisure: theoretical aspect // Bulletin of the Buryat State University*. 2009. No. 14. - p. 268-271.
2. Sokolov, E. V. *Free time and culture of leisure*. Leningrad: Lenizdat, 1977.
3. *Pedagogy of leisure: terminological dictionary / comp. O. N. Khakhlova*. Ufa: BSPU Publishing House, 2007.

4. *Krestyanov, V.P. Pedagogy of leisure: a textbook for students of pedagogical universities and higher educational institutions of culture*. Orel: OSU, 2010. -- P. 156.
5. *Kendo T. Leisure and popular culture in dynamics and development: an abstract presentation and trans. A.I. Kravchenko // Personality. Culture. Society*. 2000. T. 2. Iss. 12). - p. 283-308.
6. *Personality-oriented sociology*. Moscow: Academic project, 2004. - P. 608.
7. *Robert Pindyk, Daniel Rubinfeld "Microeconomy" "Shark", T. :, 2002.332-333-p.*
8. *Rybakova N.V. Problems of identity in the modern world // Interuniversity collection of scientific papers / E. N. Bogatyreva*. Saratov, 2007. - p. 60-66.
9. *Ryleeva, A.S. Organization of cultural and leisure activities of the population of Russia: a tutorial*. Kurgan: publishing house of the Kurgan State University, 2014. - p. 13-14.
10. *Smirnov A. V. Essence and phenomenon // New philosophical encyclopedia*. Moscow: Mysl, 2001. Vol. 3. - P. 682.
11. *Frolov E. D. Paradoxes of history - paradoxes of antiquity*. St. Petersburg: Publishing house of St. Petersburg. University, 2004. -- P. 420.



## FIGHTING AGAINST POVERTY: HISTORY AND FATE

**Kholmurodov Nozimjon Kosimovich**

*Independent Researcher, the Department of Social Sciences, Bukhara State Medical Institute*

---

### ANNOTATION

*The article reveals the essence of the concepts of poverty and deprivation, analyzes the functioning of the social protection system in the countries of the world during the period of historical development. Examples are given from Islamic sources and the views of Eastern thinkers on mercy and social assistance. The content of reforms aimed at reducing poverty in the Republic of Uzbekistan is revealed.*

**KEYWORDS.** *poverty, social protection, assistance, program, social insurance, social system.*

---

It is known that the level of development of a society is usually determined by the state's attitude to the elderly, children, the disabled in society, their standard of living, simply put, all categories of people in need of social protection.

Helping the socially vulnerable, i.e. the elderly, the disabled, the lonely, the helpless, and other categories of the population, is a testament to the high spirituality and culture of society. It is known from historical development that helping, sympathizing and donating to relatives has long been a characteristic of the peoples of different countries.

It should be noted that the holy book "Avesto" is the first written source of information about the system of social events. It contains information about the structure and social policy of the states that adopted Zoroastrianism. As a method of targeted assistance, charity is a traditional rule of conduct for ordinary citizens, while priests and religious organizations are responsible for social services - support, assistance, charitable activities. Rulers, wealthy citizens, and churches organized charity lunches and distributed charity to the poor and needy. In communities, families in need were financially supported at the expense of the general collective fund [8, 9].

The Muslim period in the history of the peoples of Central Asia continued and enriched the participation of the clergy in social life. Mosques and socio-religious communities are tasked with providing social support and assistance. Types of social assistance took individual and collective forms. The most common form of individual assistance is the fulfillment of the basic duties of Islam by everyone, including the distribution of

donations and financial assistance to the needy. Hashar is the most common type of community assistance, including the distribution of donations, medical assistance, and the establishment of special free hospitals.

Supporting and helping the poor is described in detail in Islamic philosophy, the Qur'an, and the hadiths. Mercy is to sponsor the weak, to raise the fallen, to share in the misery of others, to give alms, even if it is a sweet word, to give one's favorite thing when one is helpless, hanging a piece of food on a neighbor, even catching a hungry thief who has stolen from his garden, and giving him a head of grapes without beating him –these are innumerable beautiful feelings, such as exhortation are the most important qualities that hold a person as a human being.

Whatever is in the world, they are all created for man, for his prosperity, for his happiness. Man should be thankful for this and live in this world. This is stated in Surat al-Baqara: Allah has made the earth a base for you, and the sky a building, and sent down water from the sky, and has produced for you fruits as sustenance. So do not set up rivals to Allah while you know. [10]. Therefore, one should be engaged in pious deeds, do good deeds in this world, do good works, help others, especially the needy and the poor, give them charity, and be merciful. In general, the Qur'an and the hadiths talk a lot about a person's deeds in this world, his humanity, his observance of the rules of conduct, and his good deeds. This can be seen from the fact that the Qur'an mentions good deeds and righteous deeds 31 times, good deeds 12 times, charity, almsgiving,



compassion 40 times, and the path of guidance 5 times [11].

Alisher Navoi, the sultan of the realm of words, begins his work "Mahbub ul-qulub" by describing the righteous kings. In his view, the benefits of a just king for the country and the people are limitless. Such a king, first of all, will be equally gentle and kind to the poor and needy, to different categories of the population. A righteous king possesses high qualities and is a blessing to his subjects. Due to the efforts of the king, peace and tranquility reign in the country, and the people live happily and prosperously because of his kindness and generosity. "The food of the hungry is from the table of mercy and forgiveness, and the clothes of the naked are from the treasury of blessings and charity. The landscaping of the country garden is as abundant as a rain cloud and the sun is as bright as the eyes of the people of the country... A just king is a blessing to the people, a cause of peace and prosperity for the country. Like the sun and the spring rain, flowers bloom from the black soil, and the heads of the people of the country are strewn with gold" [5]. Alisher Navoi says that a person's dignity is determined not by his property, ornaments, position, or social background, but by his spiritual image, moral qualities, and how much he benefits from it. In this regard, his words are commendable: "If people are not able to benefit by words, at least their thoughts should be good. The heart should rejoice in the joy of the people. If you are not a real person, do not call him a man."

According to Abdurahman Jami, in order to make a good name, it is necessary to always do good to the people, to be engaged in good deeds.

Throughout his life, Hoja Ahror thought of the interests of the people and the development of the country. During the years of drought, he paid the rent of some provinces and distributed bread and wheat to the poor. For example, according to the authority of Khoja Ubaydullah Ahror, Hazrat Eshan, that is, Khoja Ahror, came to Tashkent in one year and gave 250,000 dinars to Sultan Umarshaikh to exempt Muslims from taxes. At another time, he allocated 70,000 dinars to exempt Muslims from taxes. Maqomat gives many examples of such donations of Hoja Ahror, his help to strangers. At the same time, according to the Sufi, a person should not consider himself the owner of wealth, should not boast of his wealth, should not look down on the poor, be humble, help the people, and give alms to the widows and the needy. Man must spend the world of wealth for himself, and then distribute the surplus to his relatives and the needy. Otherwise, the accumulated wealth will be left to others. "It's a strange thing," says Hoja Ahror, "that they build mansions and palaces, and that they live together, and that they leave their lands and sorrows." And the stranger is

astonished, and sits in his place, and is unaware. And he will not learn from the sorrow of his owner, as he saw with his own eyes" [9, 238].

In the works of our great thinkers, the issue of helping the poor is always in the center of attention.

If we look at the history of the peoples of the world, the establishment of the state system of social protection in Russia began in 1701 with the adoption by Emperor Peter I of the Decree "On the identification of strangers, sick and elderly in the homes of St. Patriarch." The first orphanages appeared during the reign of Emperor Peter I, and the society was tasked by the state to take measures to separate the poor and provide care for each individual category.

The formalization of the state system of social assistance in the countries of Western Europe in the XVI-XVII centuries is explained by the growing role of the state and at the same time the decline of the activity of the Christian Church. In particular, in 1529 in Germany the Hamburg charter on assistance to the needy, and in 1682 the decree on measures of the state security are accepted. In England, in 1531, the Law on Assistance to the Poor was passed, and in 1572, a national tax was introduced to help the poor. The Poverty Act of 1601 in England emphasized financial assistance to the needy. This law served as a basis for the development of legislation in this area and marked a turning point in the formation of the government's responsibility for human needs.

The American social protection system has two clearly defined directions, the social insurance system and the social assistance system. Social insurance programs have a high social status because all people who live on a salary regularly pay taxes to the appropriate funds. This system protects the economically active population from major social risks, old age, loss of a breadwinner, disability, disease, occupational injuries, unemployment. Social assistance is the second aspect of the social protection system in the United States. The U.S. assistance system includes many large and many small programs. Under these programs, people living in poverty receive cash, food, housing on credit, assistance in education, and vocational training. People living below the officially defined poverty level are eligible for social assistance. Approximately 12–15% of the U.S. population is a recipient of social assistance [8].

Article 1 of the UN Universal Declaration of Human Rights, adopted by the United Nations on December 10, 1948, states that "All people are born free, equal and equal in rights." [1] As stated in Article 13 of the Constitution of the Republic of Uzbekistan, "Democracy is based on universal principles, according to which man, his life, liberty,





honor, dignity and other inalienable rights are the highest value. Democratic rights and freedoms are protected by the Constitution and laws"[2].

It should be noted that for the first time in the history of Uzbekistan, the issue of poverty was raised in the January 24, 2020 address of the President of the Republic of Uzbekistan to the Oliy Majlis [3], which became the main agenda of socio-economic policy. Poverty reduction should be aimed at awakening the entrepreneurial spirit in the population, the full realization of the inner strength and potential of man, the implementation of a comprehensive economic and social policy to create new jobs. Moreover, the most important factor for getting out of poverty is that a person's aspiration, relying on his own strength, should be a movement towards a clear goal.

In accordance with the instructions of the President of the Republic, the World Bank, UNDP, Asian Development Bank in a short period of time to develop specific programs and mechanisms for poverty reduction, criteria and assessment methods for poverty reduction, minimum standards and regulations of social security, taking into account foreign experience 14 experts from international organizations such as the Bank were involved. Together with these experts, the "Concept of Poverty Reduction in the Republic of Uzbekistan in 2021-2023" was developed, which includes the above tasks.

The question naturally arises as to whether there is a clear definition of the concepts of poverty and destitution. At present, there is no universally accepted and agreed upon definition of poverty around the world. Each country describes it based on the poverty criteria set for it.

As defined at the UN World Summit on Social Protection, poverty is the lack of income and resources necessary for human life, as well as hunger and malnutrition, restrictions on access to health, education or other basic services, lack of housing, living in a dangerous natural and man-made environment and in conditions of social inequality.

In 2017, the UN Economic Commission for Europe's Poverty Measurement Guide defined poverty as follows: "Poverty is the lack of choices and opportunities throughout a person's life, the existence of barriers to full participation in society, as well as feeding and dressing, educating or hospitalizing, treatment, lack of employment opportunities to operate in a field or earn income, and limited access to credit. Poverty is also the social stigma and helplessness of individuals, households and communities."

As noted in the Address of the President of the Republic of Uzbekistan to the Oliy Majlis on December 29, 2020 [4], the ultimate goal of economic reforms in 2021 is to reduce poverty and

increase the welfare of the population. A number of tasks have been set to achieve this goal, including:

First, the development of the draft "Strategy for Poverty Reduction in the Republic of Uzbekistan until 2030" in cooperation with a number of international organizations, such as the United Nations Development Program, the World Bank;

Second, the introduction of a comprehensive approach and non-standard methods of poverty reduction, ie the completion of calculations based on an in-depth analysis with international experts on ensuring the basic needs of the poor, and the introduction of "Minimum Consumption Costs" from March 1 this year. This will address complex issues related to education, health, vocational training, drinking water, energy and road infrastructure, along with the provision of credit, social benefits or housing to the poor;

Third, to correctly identify the needy population and, on this basis, to create a system of targeted work with them;

Fourth, the "Social Register", which will be fully operational next year, will cover all the information in the "Iron Book" and provide more than 30 social services to needy families in electronic form;

Fifth, to develop a program to bring social guarantees into one system and gradually provide them at the level of minimum norms;

Sixth, develop ways to mobilize the existing capacity of the regions to reduce poverty;

Seventh, the development of a draft resolution on the vocational training of young people and women, their employment through the support of entrepreneurial initiatives and the introduction of a new mechanism for creating a sustainable source of income;

Eighth, to further develop cooperation with foreign institutions involved in and responsible for poverty reduction.

In short, the glorification, protection and all-round development of man has become the main idea of the new Uzbekistan. It vividly embodies that the greatest of all worldly blessings is "man."

## REFERENCES

1. *Comments on the Universal Declaration of Human Rights. T. : 1999*
2. *The Constitution of the Republic of Uzbekistan. T.: 2018*
3. *Address of the President of the Republic of Uzbekistan to the Oliy Majlis (January 24, 2020).*
4. *Address of the President of the Republic of Uzbekistan to the Oliy Majlis (December 29, 2020).*
5. *Alisher Navoi. Mahbub ul-qulub. MAT. T.14. – Tashkent: Fan, 1998. –p. 12.*





6. *Alisher Navoi. Hayratul-abror - T .: Ghafur Ghulam Publishing House of Literature and Art, 1989.*
7. *Kuzmin K.V., Sutyryn B.A. History of social work for the ruble and in Russia (from antiquity to the beginning of the XX century). - M .: Academical project; Ekaterinburg: Work book, 2002. - p. 11.*
8. *M.H.Ganieva "Fundamentals of social work" (methodical manual). T.: 2010, p.9*
9. *Hoja Ubaydullah Ahror. Sacred brochures. – Tashkent: Adolat, 2007.–p. 109.*
10. *Translation of the meanings of the Holy Quran. Surah Al-Isra - T .: TIU. 2001. - 288 p.*
11. *On the path of goodness. - T .: Cholpon, 2006. - 70 p.*



# A STUDY ON FINANCIAL PERFORMANCE ANALYSIS OF HDFC BANK LTD

<sup>1</sup>Mr. S. Muruganatham, <sup>2</sup>Mr. S. K. Nidish

<sup>1</sup>Assistant Professor, Department of Commerce with Professional Accounting,  
Dr.N.G.P. Arts and Science College, Coimbatore

<sup>2</sup>181PA037, Department of Commerce with Professional Accounting,  
Dr.N.G.P. Arts and Science College, Coimbatore

## ABSTRACT

*Financial performance is the process of measuring how effectively a company utilizes its assets from primary mode of business to raise incomes. The study used 5 years of HDFC's secondary data and main objective is to find out the performance ratios of the bank that can be helpful in finding the growth aspects of the bank. The various tools like Return on assets ratio, Interest coverage ratio, and other performance ratios were used for the study. The suggestions reveal bank is generating sufficient income and they are making better profits but efficiency of the bank in generating profits is limited. Finally, Bank is performing well in terms of income and it is satisfactory.*

**KEYWORDS:** Performance ratios, Growth aspects, Income efficiency.

## 1. INTRODUCTION

Financial performance analysis is the process of identifying the financial strengths and weaknesses of the firm by properly establishing the relationship between the items of balance sheet and profit and loss account. It also helps in short-term and long-term forecasting and growth can be identified with the help of various financial tools in financial performance analysis. Bank plays a crucial role in the development of Indian economy. A sound and an efficient banking system in developing countries provide the necessary financial inputs to the economy. It also measures organizations whole financial health over a particular period of time. Financial performance of the organization deals with the financial strength and weaknesses of bank accurately establishing a relationship between the balance sheet and income statement.

## 2. STATEMENT OF THE PROBLEM

Banking Facilities are increasing day by day and the studies and researches conducted on these private banks are limited. Before privatization, only public sector banks are there in the country, after privatization, private sector banks started to emerge and some banks are failed due to lack of research

among their problems and no change of trends and also on bad loans. Even then many banks are successfully running in the country. Financial Performance of the bank will be stable, only when banks are maintaining proper Financial Statements. The HDFC Bank offers lot of customer benefits that helps the Bank to attract customers faster. This particular study explains all about financial performance analysis of HDFC Bank with the reference of last five years financial statements and also explains about the findings about expansion of bank, deposits, loan lending and credit expansion for the business and other people.

## 3. OBJECTIVE OF THE STUDY

- To measure HDFC Bank financial results.
- To analyse the financial & Performance analysis of the bank by using different ratios.
- To study and analyse the financial performance of HDFC Ltd for the period of five years from 2015-2016 to 2019-2020.
- To study the growth aspects of HDFC Bank.
- To offer suggestions that are based on the findings of the study.



#### 4. RESEARCH METHODOLOGY

Source of Data	Secondary data
Period of Study	2015-2016 to 2019 – 2020
Framework of analysis	Financial Statements
Tools and Techniques	Ratio analysis

#### 5. STATISTICAL TOOLS

The following statistical tools were applied to analyse the statistical data collected for calculation of financial performance analysis:

- Return on Assets Ratio (%)
- Interest Coverage Ratio (%)
- Ratio of Interest Income to Total Assets (%)
- Ratio of Non-Interest Income to Total Assets (%)
- Ratio of Operating expenses to Total assets (%)
- CASA Ratio (%)
- Net Interest Margin (%)
- Net Profit Margin (%)
- Cost-to-Income Ratio (%)

#### 6. REVIEW OF LITERATURE

**Bangaru Pushpalatha (2020)**, ‘analysed the financial statements of State Bank of India. The objectives are examine the portfolio of assets and liabilities in SBI. Researcher limited the study to 7 years starting from 2011 to 2017. Researcher used

‘T’ test to determine the relative importance of each variable. The study reported SBI have healthier managing and financial efficiency. It also reported people prefer SBI for advance loan schemes.’

**Nandhini Thakur (2020)**, ‘The study is conducted on financial statement analysis of HDFC Bank with the time period of 2013-14 to 2017-18. Tools used in this study was ratio analysis, cash and fund flow analysis trend analysis. The objective is to measure the efficiency of various properties of bank. Researchers find that bank’s financial performance was strong and suggested to providing more housing loans to the development of the citizen of India.’

**Rajendran P (2019)**, ‘analysed the performance of HDFC Bank. Researcher explained about HDFC Bank’s history. Current ratio, cash position ratio, Debt equity ratio and proprietary ratio was good. The study finds that part of working capital of the bank was financed by long term funds. Researcher concluded with result as HDFC Bank was the largest private sector bank in India and its financial performance was strong during the period of study.’

#### 7. TABLE

Year	Return on Assets Ratio (%)	Interest Coverage Ratio (%)	CASA Ratio (%)	Net Interest Ratio (%)	Net Profit Ratio (%)	Cost-to-Income Ratio (%)
2015-16	1.75	4.67	43.26	3.98	20.29	44.24
2016-17	1.71	4.26	48.04	3.95	20.86	43.13
2017-18	1.68	3.84	43.48	3.89	21.76	42.61
2018-19	1.73	4.15	42.36	3.98	21.34	39.34
2019-20	1.72	3.93	42.19	3.80	22.34	38.90

- The Return on Assets Ratio (%) was higher during 2015-16 with the ratio of 1.75 and it is lower with the ratio of 1.68 during 2017-18. The Ratios are almost same in these years and it shows that the efficiency of the Bank is poor when comparing to previous years but it is not affected too much.
- The Interest Coverage Ratio (%) was higher during 2015-16 with the ratio of 4.67 and it is lower with the ratio of 3.93 during 2019-20. The ratio shows that the expenses are

comparatively low every year when it is comparing to assets of the Bank.

- The CASA Ratio (%) was higher during 2016-17 with the ratio of 48.04 and it is lower with the ratio of 42.19 during 2019-20. The ratios are becoming low in the previous years, it depicts deposits are becoming low and the term deposits are becoming high, it shows bank gets low amount of money at lower cost.



- The Net Interest Margin (%) was higher during 2015-16 and 2018-19 with the ratio of 3.98 and it is lower with the ratio of 3.80 during 2019-20. The borrowings of the bank are reduced and the deposits are increased.
- The Net Profit Margin (%) was higher during 2019-20 with the ratio of 22.34 and it is lower with the ratio of 20.29 during 2015-16. The Net Profit was increasing every year and it is also expected to be increased in the future years.
- The Cosy-to-Income Ratio (%) was higher during 2015-16 with the ratio of 44.24 and it is lower with the ratio of 38.90 during 2019-20. As the ratios are decreasing, it depicts profitability of the HDFC Bank is doing good.

## 8. SUGGESTIONS

- The Return on Assets Ratio is becoming lower every year. It shows that bank's management having less efficient in managing the balance sheet in generating profits. So, I suggest the bank to focus on generating profits for the Bank.
- The Ratio of Interest Income to Total Assets was lower in the past years. It shows that Interest Income on loans are reduced when it is compared to the assets of the bank. I suggest the bank to focus more on lending loans to the customers.
- The CASA Ratio is decreasing after 2017-18, the term deposits are high in these years, and current & Savings account deposits are lower when it is compared to the term deposits. So, the bank is paying more interest on the term deposits, it may reduce the profit of the concern. The HDFC Bank has to focus on the customers who made current and savings deposits on the bank.
- The Net Profit Margin is continuously increasing every year, I suggest the Management of HDFC Bank to go on the same way and to improve additional technology factors which make customer more user-friendly and also it helps the bank to remain No.1 Bank by customers in India in the future years also.

## 9. CONCLUSION

The Financial position of the concern can be analysed with the help of the ratios. The study used various key performance banking ratios. The study has been made on various aspects of the bank like interest, loans, assets, expenses, deposits, etc. The

Findings of the study reveals that the bank has some minority issues in managing the deposits and all other aspects are going well. The suggestions relating to solving the minority issues is also given in this study. Finally, The Financial Performance of HDFC Bank from 2015-16 to 2019-20 is satisfactory. This study will be helpful for the researchers to analyse the financial performance of HDFC Bank in the future.

## 10. REFERENCE

1. *Shasi K Gupta & Sharma R. K, Management Accounting, New Delhi, Kalyani Publications, 2011.*
2. *Maheswari S. N, Accounting Management and Financial Control, New Delhi, Sultan Chand and Sons, 2009.*
3. *Reddy T. S. & Hari Prasad Reddy Y, Management Accounting, Chennai, Margham Publications, 2010.*
4. *Bangaru Pushpalatha (2020), "Financial Performance Analysis of SBI an Empirical Study", Journal of Emerging Technologies and Innovative Research, Volume 7, Issue 2, pp. no. 192-196.*
5. *Nandini Thakur & Shiva M (2020), "A Study on Financial Performance Analysis of HDFC Bank", Mukta Shabd Journal, Volume 9, Issue 6, pp. no. 2343-2353.*
6. *Rajendran P & Dr. B Sudha (2019), "A Study on Financial analysis and performance of HDFC Bank", Journal for the study and research, Volume 11, Issue 11, pp. no. 37-49.*
7. *Srilakshmi Ramu & S V Satyanarayana (2019), "Financial Performance analysis of HDFC using Dupont Analysis", Inspira-Journal of Commerce, Economics & Computer Science, Volume 5 No. 2, pp. no. 46-52.*
8. *Dr. D Pathma Priya (2019), "A Study on financial performance analysis of HDFC Limited", The research journal for social sciences, Volume 10 No. 4 pp. no. 301-311.*
9. *Nirmala M & Dr. K S Kavitha (2019), "A study on Financial Performance of HDFC Bank", Suraj Punji Journal for Multidisciplinary Research, Volume 9, Issue 5, pp. no. 406-415.*

## WEBSITES

1. <https://www.hdfcbank.com/personal/about-us/investor-relations/annual-reports>
2. <https://www.moneycontrol.com/india/stockpricequote/banks-private-sector/hdfcbank/HDF01>
3. <https://economictimes.indiatimes.com/hdfc-bank-ltd/stocks/companyid-9195.cms?from=mdr>
4. <https://www.capitalmarket.com/Company-Information/Information/About-Company/HDFC-Bank-Ltd/4987>



# SOCIO-PHILOSOPHICAL PROBLEMS OF DEVELOPMENT OF ECOLOGICAL CULTURE OF UZBEK PEOPLE

**Yuldasheva Diloram**  
*Samarkand State Medical Institute*

---

## ANNOTATION

*This article examines the problems and ways of solving environmental values that contribute to the harmony of nature and culture, as well as the development trends of the traditional and modern environmental culture of the Uzbek people.*

**KEYWORDS.** *Ecology, geoculture, traditions, fauna, culture.*

---

People have long known about the existence of interconnection and harmony in the elements of nature. Ancient historians had the skills and experiences that each phenomenon has an impact and impact on each other. Modern historians, equipped with modern technologies, having better knowledge and skills, pay great attention to the interconnection of natural processes and phenomena. It should be noted that humanity has now begun to realize that the reason for many unsuccessful experiments was ignorance of the relationship of many natural phenomena.

Unfortunately, ecological crises cannot be solved only by means of modern ecological culture. The President of the Republic of Uzbekistan Shavkat Mirziyoyev in his speech at the conference in the city of Turkmenbashi in the Republic of Turkmenistan devoted to the rescue of Aral s of the Sea has expressed an opinion concerning our research: "I believe that people, based centuries-old traditions, will protect the nature with its wealth and will wisely use the common water resources, and only then can we achieve great success" [1, p. 1]. Drawing conclusions, we can say that the revival and development of traditional ecological culture, tested for centuries, is becoming more relevant.

Based on this, we tried to identify the main branches of folk ecological culture. Traditional folk ecology is associated with almost all types of ethnoculture and merged into them. In those sectors such as the folk wisdom, folk belief folk pedagogy, culture, rites festivals, folk games, folk art, culture recreation, folk cooking, folk architecture, traditional medicine is closely related to the problems of nature and ecology.

The conceptual basis of folk ecological culture is the philosophy of folk ecology. This part of the ecological culture reflects the ideas, opinions, perceptions, worldviews of the people related to nature, to the surrounding world. We can meet folk wisdom related to ecology in conversations, in councils of elderly people, in phraseological units and aphorisms known to the people.

Folk art related to nature (ecofolklore) is also reflected as an integral part of ecological culture. The meaning and form of proverbs, riddles, legends, fairy tales, dances, performances, connectivity for e people with nature Art and figuratively expresses his attitude to the native land, water, air, flora and fauna.

Even wounds n nn f of the yoke of human culture as folk games - expresses counteract nature. Later they developed as performances and turned into folk games as wrestling, catch-up, horse racing, etc., which at the beginning expressed the opposition of nature, the struggle between winter and spring.

Other types of popular ecological culture perform the following tasks: a popular belief - to protect natural values, folk pedagogy - conducting eco education, holidays, rituals - the celebration of the seasons, important phenomena of nature, culture recreation - rest, not causing harm and the environment, traditional cooking - prepare unusual dishes from natural products, traditional medicine - treatment of patients with natural elements, medicinal plants, herbs.

The revival of spiritual and ecological values, which helps us to combine nature and culture, awakens in us feelings of loyalty to the Motherland, gratitude for every day. Enriches the creative activity of every person who has a profession, arises a sense





of pride in his dedicated work, contributes to the development of his work, improves his specialty. In addition, the cultural understanding of people related to nature is expanding, the cultural level is increasing. Each holiday, tradition, event helps to preserve nature, to bring it to the next generation in its purest form. As a result, all conditions are made so that people spend their time in an exciting, interesting way, without causing harm to nature.

The completeness and culture of a person is also determined by his attitude to nature. The German scientist I. Kant, understanding nature by human behavior, said: "Whoever is directly interested in the beauty of nature, this suggests that he has the ability to think, good breeding, kindness" [2, p. 314]. Therefore, the harmony of nature and culture is a common way of life for mankind. The improvement of such a way of life leads a person's life to well-being, his spiritual life to perfection.

For example, the Uzbek people consider it a sin to pollute water, to spit into it. Each custom has its own reasons, and in this case, there are reasons. To provide water to the inhabitants of the city of ancient Samarkand, clay pipes were used. In the city, one ditch surrounded the whole city and left the city. With the help of these pipes of irrigation ditches the city flourished, gardens were irrigated, residents drank water from this source. These pipes kept water from contamination and made it possible to save water. But who can give guarantees about the involuntary pollution of these waters in such a big city? Such a guarantee is given by the spiritual side of humanity, the level of its culture. Since in those days, everyone considered it a sin to pollute the water. Not only in Samarkand, but also in every city of Central Asia, of course, there were ditches. With the help of these waters, agriculture was irrigated, it was used as a source of drinking. Nowadays, when drinking water is a big problem, if we turn to such ancient customs and experiences, if we restore communication with nature, then we will achieve great success.

The people in Central Asia, including the Uzbek people, are listening to the culture of frugality. This applies to all subjects that require labor, to everyday life. The people call this culture abbreviated as "sin". Waste use of such natural resources as water, soil, plants is also considered a sin. Actions opposed to behaviors, excessive consumption of food, unlimited use of natural resources for personal enrichment, poisoning crops - all this is considered a sin. Therefore, at one time, Abdurauf Fitrat, urging everyone to be vigilant, wrote: "The members of that nation who have been embezzled will undoubtedly perish. If we turn to the

history of the world, then many perished because of such waste" [3, p.136].

As V. Turaev writes, "the most important opposition between real society and nature is human efforts to control the mobile balance in nature leads to its destruction" [4, p.124].

Natural and cultural factors that help social progress, traditions related to the Uzbek folk ecological culture, currently have the following qualities:

First, these scientists educate citizens in the spirit of love for nature.

Secondly, it protects a person from distance from nature, from the disappearance of the feeling of pleasure from the beauty of nature.

Thirdly, it serves to preserve the species of animals and plants, to bring the reserves of land and water for the next generation in a pure form.

Fourth, it provides an opportunity to preserve the natural environment without diminishing the level of its progress.

To revive the natural and cultural values invented by our people for many centuries, to renew such ecological traditions, to transfer all this without damage to the new generation is an urgent task of today.

The foundations of the Uzbek folk ecological culture, which help to solve modern ecological problems, go back to ancient times. Considering all this, one must treat this from the point of view of independence. For this, every citizen must renew respect for the natural elements; to instill in the soul of the young generation feelings of kindness to water, land, flora and fauna; celebrate the holidays Navruz, Mehrjon more sublimely, celebrate the holidays of Water and Garden in their modern form; conducts bio and zoo events (a holiday of flowers and birds), effectively using the four elements of nature - earth, water, light and air, which help a person to always be respected.

Approaching from this side, the following conclusions can be drawn:

First, for the study of traditional folk ecological culture as a single and multifaceted phenomenon, it is important to identify its meaning, the main type. Based on this, it is possible to determine the main branches of folk ecological culture. As part of the system of traditional folk ecological spirituality, one can single out such branches associated with nature as folk wisdom, folk belief, folk pedagogy, culture of holidays and rituals, folk games, folk art, recreation culture, folk cookery, folk architecture, folk medicine.

Secondly, the conceptual basis of folk ecological culture is the philosophy of folk ecology. This part of the ecological culture reflects the ideas, opinions, perceptions, worldviews of the



people related to nature, to the surrounding world. We can meet folk wisdom related to ecology in conversations, in councils of elderly people, in phraseological units and aphorisms known to the people. Folk art related to nature (ecofolklore) is also reflected as an integral part of ecological culture. In the meanings and forms of proverbs, riddles, legends, fairy tales, dances, performances, people associated with nature artistically express their attitude to their homeland, water, air, flora and fauna.

Thirdly, the harmony of nature and culture is the usual way of life for mankind. The improvement of such a way of life leads a person's life to well-being, his spiritual life to perfection.

Fourth, the people in Central Asia, including the Uzbek people, are listening to the culture of frugality. This applies to all subjects that require labor, to everyday life. The people call this culture abbreviated as "sin". Waste use of such natural resources as water, soil, plants is also considered a sin. Actions that oppose behaviors, excessive food intake, the unlimited use of natural resources for personal enrichment, and the poisoning of crops are all considered sinful.

Fifth, to revive the natural and cultural values invented by our people for many centuries, to renew such ecological traditions, to transfer all this without damage to the new generation is an urgent task of today.

## BIBLIOGRAPHY

1. *Mirziyoyev Sh.M. Speech at a meeting of the International Fund of the Council of State. leaders for the rescue of the Aral Sea, held in the city of Turkmenbashi in Turkmenistan. The newspaper "Narodnoye Slovo". 2018, 25 August. 173 (7131) p. 1*
2. *Kant I. Works in 6 volumes. V.5. M., "Thought", 1966. S. 314*
3. *Fitrat, Abdurauf. Selected works: 6v. - T. 1: "Education", 2010.- P.136*
4. *Turaev V. The threat of globalization to mankind // Foreign literature, 2003. №12.-C.124*



# TRADITIONAL ETHNOVETERINARY PRACTICES FROM SATPUDA FOREST REGION OF BURHANPUR DISTRICT MADHYA PRADESH, INDIA

<sup>1</sup>Dr.Zahid Hasan Jafri, <sup>2</sup>R. M. Bagul\* <sup>3</sup>Prof.Azhar Uddin



## ABSTRACT

*The present paper deals with the traditional ethnoveterinary medicinal plants species used for various diseases by Pawara, Barela & Bhil tribes. 26 plant species of 26 genera belonging to 23 families with their local name, botanical name, family, and plant part used, preparation of remedies, disease treated, and doses recorded are given.*

**KEYWORDS** - Ethnoveterinary, Satpuda, Burhanpur, Madhya Pradesh

## INTRODUCTION

Burhanpur forest area of Satpuda forest falls in northern part of district .It is situated between 21°18' and 76°14' North latitude & 21.3° and 76.23° East longitude. The vegetation composed of humid & many semi-evergreen species apart from dry deciduous ones. Tribals are the Inhabitants of the area with the several tribes like Pawara; Barela & Bhills.Traditionally medicinal plants are much in use. Studies on the medicinal plants of the area are lacking except few sporadic references like Jain, S.K.1963, 1999; Maheshwari, J.K.1966, 1989; Rai, B.K.Ayachi, S.S, Rai A. 1996; Rai.R. Nath.V, Shukla, PK, 1996, 2002, 2003, 2004; Rai.R.2004; Rai. R.Nath.V,Shukla,PK,2004a,b,c; Saxena,P.o.1988; Mini Vand Sivdasan M 2007; Rahman,.et-al 2009; Satya V and Solanki Cm 2009; Yadav D 2009;. However

## MATERIALS AND METHODS

Extensive & intensive explorations on every Sunday and Saturday of the week end to collect all the information as far as possible regarding the medicinal uses. During outgoing all the information collected were noted in field book. Pertinent attention was paid to habit, habitat, parts used, and diseases for which plants used, dosages and mode of administration. As far as possible correct local names have been recorded.

studies on stapura forest from various regions had been carried out by Karnik, C.R.. Karnik, CR. & Basu, BD. 1935, Karnik, and CK. 1935. Karnik, C.R. 1961. Mahabale, TS. & Karnik, CR.1959 Anonymous, 1994. Ayensu, ES. 1981. Bagul, R.M. and Yadav, S.S. 2003a. Bagul, R.M. and Yadav, S.S. and Garud, B.D. 2006. Bagul, R.M. and Yadav, S.S. 2007. Bagul, R.M. & D.K. Patil. 2011. Bagul, R.M.2011. Bagul, RM. 2013. R.M.Bagul, (2015),

As far as studies on ethnoveterinary medicinal plants of Burhanpur district concern there are no reports so far. Attempt has been made to collect information about ethnoveterinary medicinal plants from tribals of the area. Present study is based on field survey of personal discussion with local village health practitioners (LVHP), & literature survey from, June 2012-2014.

These information were confirmed with repeated queries at different places.(Table no. 1.)

Specimens collected during the field work are processed for herbarium as per the customary methods (Jain and Rao, 1977). Specimens are thoroughly studied for correct identification with the help of the standard Flora of the Presidency of Bombay(Cook, 1958 Repr.ed.), Flora of British India(1872-1897), BSI Flora of Maharashtra state Vol,I,II, & III.(Edited by Sharma et al.1996,Singh and Kartikeyan 2000;Singh & Laksh 2001).The identification was also confirmed by



matching the specimens with that of authentically identified species at BSI Pune. Herbarium sheets were neatly labeled and deposited in herbarium of

department of botany arts, Science & Commerce college Chopda.

**Table no 1- Showing botanical name, local name, family, part(s) used, ethnoveterinary medicinal uses.**

Botanical name	Local name	Family	Part(s) used	Ethnoveterinary medicinal uses
<i>Abitulon indicum(L).Sw.</i>	Aatti	Malvaceae	Roots	100g roots added daily to feed on Galctogogue
<i>Achyranthes aspera L.</i>	Aghada	Amaranthaceae	Leaf	Leaves powdered into paste Is applied on genital part and allowed to inhale the easy delivery & retained placenta.
<i>Aegle marmelous(L).Corr</i>	Bel	Rutaceae	Leaf	Paste is made with 1 kg of leaves powdered with cymbogon lvs & curcuma domestica rhizomes and used on dyspepsia.
<i>Andrographis paniculata (Burn.f.)Wall</i>	Bhuinimb	Acanthaceae	Leaf	100g coriandrum fruits & 10g of piper nigrum crushed together with water, filtrate obtained is given for three days to cure Babesiosis.
<i>Azadirecta indica A.Juss.</i>	Neem	Meliaceae	Leaf, bark	10g of leaf of andrographis & 10g of curcuma roots powdered to make paste with neem leaf is applied on worm infection. Same is applied on foot of cattle diseases. Fruit oil is applied on mouth dieses.
<i>Bambusa vulgaris Schrader wendl.</i>	Bamboo	Poaceae	Young shoots	Young shoots paste made with jaggery fed to cattle & buffaloes on diarrhea.
<i>Biophytum sensitivum(L)DC</i>	Lajari	Oxalidaceae	Whole plant	Fresh plants are fed to lactating cow as galactogogue.
<i>Cassia fistula L.</i>	Bahava	Cesalpiniaceae	Ripen pods	Ghee applied on pods warm gently on flame to use on swollen throat of cattle.
<i>Diospyros melanoxylon Roxb</i>	Tembhurni	Ebenaceae	Fruits	10g of fruit pulp mixed with small water is applied on eye disease
<i>Erythrina variegata L.</i>	Pangara	Fabaceae	Leaf	Leaf paste is applied on neck to cure yoke sore.
<i>Ficus racemosa L.</i>	Umber	Moraceae	Latex	Fresh latex collected is applied on wound healing of cattles.
<i>Gossypium herbacium L</i>	Kapas	Malvaceae	Leaves	Leaf juice is given orally for suppuration of waist after delivery.
<i>Bombax cieba L</i>	Saber	Bombacaceae	Seed	50g of seed powder given twice daily for measles.
<i>Holarrhena antidysentrica(BuchHam)Wall.exG.Don</i>	Kuda	Apocynaceae	Roots	Paste was made with 20g root bark of kuda mixed equally with fruit pulp of punica granatum & a pinch of salt added & given orally for controlling diarrhea.
<i>Madhuca longifolia</i>	Mahu	Sapotaceae	Seeds	Cake obtained after oil extraction is applied on worms.
<i>Nyctanthes arbor-tritis L</i>	Chandani	Apocynaceae	Leaf/Bark	Decoction made with 500ml leaf juice & 20g piper fruits to make final volume ½ litre is given twice daily on fever for



				three days.
<i>Puereria tuberosa (Roxb.ex willd.)DC.</i>	Bhui kuda	Fabaceae	Roots	Roots powdered with water and given orally to cow as galactogogue.
<i>Psidium guajava L</i>	Peru	Myrtaceae	Leaf	20-30g of leaves pounded with 10g syzigium & mango leaf 10g, given on the treatment of dysentery.
<i>Strychnos potatorum L.f.</i>	Nirmali	Longaniaceae	Fruits	Fruit pulp is applied on wound healing.
<i>Terminalia arjuna(Roxb.exDC)W &amp;A.</i>	Hirda	Combrataceae	Leaves	200ml of leaf juice made with water given twice daily for suppuration of waist after delivery.
<i>Vitex negundo L.</i>	Nirgudi	Vitaceae	Leaves	20ml leaf juice made with 20g of elettaria cardamom are boiled to make half used for two times daily on rheumatism.
<i>Lawsonian inermis L.</i>	Mendi	Lithraceae	Bark	Decoction made with 200-300g bark & 1 liter of water to make final volume 1/2kg
<i>Leucas cephalotus(Roth)Spr.</i>	Gobi	Labiatae	Whole plant	Whole plant made into paste with piper seeds ,5g & given twice orally as antidote on snake bite
<i>Citrus colocynths (L.)Schrad.</i>	Govindphal	Cucurbitaceae	Seeds	Seed powder is applied on foot cracks of cattles.
<i>Hardwickia binata Roxb</i>	Anjan	Cesalpiniaceae	Leaves	Leaves are used for improving milk production in cattles.
<i>Holoptelia integrifolia (Roxb.)Planch</i>	Papda	Ulmaceae	Seed	Seed paste is used for tick & mite killing externally.
<i>Annona squamosa L.</i>	Sitaphal	Annonaceae	Seeds	Seed powder is made with water & applied externally to kill lice.

## DISCUSSION AND CONCLUSION

During study it was found that 27 type of plants species used on 23 type of diseases belonging to 23 families, 27 genera & 27 species used to cure veterinary diseases like wound healing, enhancement lactation, diarrhea, dysentery, cold, cough, suppression of lactation after delivery, constipation, mouth diseases, flea, lice, tick & mite repellent, babesiosis, abdominal pain, worm infections, measles retained placenta, easy delivery, snake bite, dyspepsia, fever, bone fracture and tooth diseases. Most of the information reported from the tribal's of the area is found to be less known to the literature of Indian veterinary medicinal plants. The plants mentioned here are still popular in this area and enjoyed good reputation in traditional medicines used on veterinary diseases. Most of the drugs are utilized in fresh mode and as a cooled decoctions or infusions. It is necessary to make further investigations on these ethno medicines for conservation of biodiversity to protect extinction of the Ethnoveterinary medicinal plants. There is also need to brought these plants under

cultivation in a systematic manner to meet demands from traditional drug based market. It is also needed to evaluate pharmacologically the efficiency of these plants against Ethnoveterinary claim

## AUTHOR PROFILE

Zahid Hasan Jafri receive M.Sc Botany from devi ahilya vishwa vidyalaya, indore and M.Phil Botany in Vikram Uni Ujjain 2009. Ph.D is completed in 2020 in KBCNMU Jalgaon Maharashtra, India. Presently working as Ad hock base assistant professor in Botany Department and pg center in Botany at S.G.J.Quaderia College in Burhanpur Madhya Pradesh India I have 13 year teaching in UG and PG Botany. Specialization in Industrial Microbiology and Ethnoveterinary Medicinal Plants.

## ACKNOWLEDGEMENTS

The authors are thankful to Mr. R.M.Bagul, my research guide head of botany





department mgms college chopda and Dr.Deshmukh for providing the shelter and facilities to complete the study.

I would like to thanks ali asgar bhai takliwala secretary of the Quaderia edu society, I thanks to Prof.M.H.Saleem Director of the college,I

thanks to prof i.a .siddiui Principal of the institute.i thanks to Thanks to Dr.Sakun mishra prof.nikhat yasmeen,Prof.Rehan Shaik ,Shakera ansari, etc.and others the team of field researchers who were participated in the collection and documentation. and accompanied us in the field study.

## REFERENCES

1. Anonymous, 1994. *Ethnobotany in India A status report (Ministry of Environment and Forests, Govt. of India).*
2. Ayensu, ES. 1981. *Medicinal plants of West Indies, reference publication Inc, Algonac, Michigan, USA.*
3. Bagul, R.M. and Yadav, S.S. 2003a. *Tribal Medicine for Jaundice from East Khandesh, Satpuda, Gobies*, 30: 295-296.
4. Bagul, R.M. and Yadav, S.S. 2003b. *Antivenomouse Traditional Medicine from Satpuda, East Khandesh, Plant Archives*, 3(2): 319-320.
5. Bagul, R.M. and Yadav, S.S. and Garud, B.D. 2006. *Medicinal Plants of East Khandesh Satpuda with Reference to Their Threat Status and Uses. Plant Archives*, 6(1): 357-358.
6. Bagul, R.M. and Yadav, S.S. 2007. *Threat Assessment of Some Medicinal Important Plants of Satpuda Forest East Khandesh: A Conservative Approach, Plant Archives* 7(1): 367-370.
7. Bagul, R.M. & D.K. Patil. 2011. *Traditional Medicines and healthcare system of tribal's of Shirpur Tehshil of Satpuda Forest, Plant archives, Vol.11 No.1, pp.271-273.*
8. Bagul, R.M. 2011. *Ecofriendly Food and Vegetable Plants from Satpuda Forest region of East Khandesh. Plant archives, Vol.11 No.1, pp. 337-338.*
9. Bagul, RM. 2013. *Traditional Medicines and Healthcare Systems of Tribal's of Satpuda forest region of east Khandesh, WJPR*, 1(1):06-09.
10. R.M.Bagul, 2015, *Traditional Ethnoveterinary Practices, Medicinal Plants from Satpuda Forest, East Khandesh, Maharashtra, India IJSR, Vol.4, Issue 5, May 2015, pp 2714-2720.*
11. Cook, Th, 1958 (Repr.ed.) *Flora of Presidency of Bombay Vol. I, II & III. Bot, Surv. India, Calcutta.*
12. Hooker, J. D. 1872-1897. *Flora of British India. 7 Vols Reeve and Co. Ltd. England*
13. Jain, S.K. and Rao, R.R. 1976 *A Hand book of Field and Herbarium Methods. Today and Tomorrow Printers and Publishers, New Delhi pp 33-58.*
14. Jain, S.K. 1963. *Observations on Ethno botany of tribal's of M.P., Vanyajati* 11(4):177-178
15. Jain, S.K. 1999. *Dictionary of Ethnoveterinary Plants, Deep publications, New Delhi*
16. Karnik, CR. & Basu, BD. 1935.
17. Indian medicinal plants, Calcutta, Karnik, CK. 1935. *A Contribution of the biogeographically studies of with special reference to Satpuda range. Bombay Georg. Mag.*, 1:65-72,
18. Karnik, C.R. 1961. *Studies on the flora and vegetation of Satpuras, Bombay State (India), with a note on the Satpura Mountains, Indian forester*, 62:173- 183,
19. Khare, CP. 2004. *Encyclopedia of Indian Medicinal plants, Springer, Germany, pp 376.* Mahabale, TS. & Karnik, CR. 1959; *Ecology of Satpura forest, India. Jour. Univ. Poona.* 16:61-73.
20. Maheshwari, J.K. 1989. *Case study of three primitive tribes of Madhya Pradesh of Central India, Methods and Approaches in Central India, Society of Ethnobotanist, Luchnow: 187-188.*
21. Maheshwari, J.K. 1996. *Ethnobotanical documentation of primitive tribes of Madhya Pradesh. J. Econ. Taxon. Bot. Additional series* 12:206-213.
22. Mani V and Sivdasn M, 2007. *Plants used in Ethnoveterinary medicine by Kurichya Tribes of Wayanad district in Kerala India, Ethnobotany* 19:94-99.
23. Rai, B.K., Ayachi, S.S., Rai, A. 1996 *A note on Etnomedicines from Central India. J. Econ. Taxon. Bot. Additional series* 12:186-191.
24. Rai, B.K. Nath V, Shukla P.K. 2002. *Ethnomedicinal studies of Bhartiya Tribes of Satpura plateau of Madhya Pradesh. Agricultureist* 13(1&2):109-191.
25. Rai, B.K. Nath V, Shukla P.K. 2003. *Ethnobiology of Hill Korwa Tribes Chhattisgarh Journal of Tropical Forestry, SFRI, Jabalpur* 19(1&2): 35-46.
26. Rai, B.K. 2004; *Madhya Pradesh ke Adivasiva van aushadhi ka Prayog, Arnyotsav: 1920*
27. Rai, B.K. Nath V, Shukla P.K. 2004(a). *Ethnobotanical studies in Patakot Valley in Chhindwara district of Madhya Pradesh. Journal of Tropical Forestry, SFRI, Jabalpur* 20(2):38. 28. Rai, B.K. Nath V, Shukla P.K. 2004(b). *Characteristics and Ethnobotanical Studies on Primitive tribes of Madhya Pradesh, Rai, B.K. Nath V, Shukla P.K. 2004(C). In Govils (edited) recent progress in Medicinal plants Chspter Ethno-medicine and Pharmacognocny. New Delhi: Research Book Center, p; 8(37)543- 552.*
28. Rai, B.K. Nath V, Shukla P.K. 2004(c). *Ethnobiological studies on Bhartiya tribes of Madhya Pradesh. 1 of Tropical Forestry* 20(1):150-160.
29. Satya V and Solanki C.M. 2009. *Indegenous knowledge of veterinary medicines among tribes of*



- West Nimar, Madhya Pradesh, Indian J. Trad.Knowledge, 33:896- 902.*
31. Saxena H.O..1983. *Observation on ethno botany of Madhya Pradesh,Bull. Bot.Survey of India, 28:149-156.*
32. Singh & Kathikey, 2000, Singh &Laksh,2001.B.S.I.Floraof M.S StatevolI,II,III. Rahman, C.H. Ghosh A. and Mandal S 2009.
- Studies on Ethnoveternary Medicinal Plants used by the Tribes of Birbhum districtWest,Bengal.,IndianJ.Trad.Knowledge.64,5: 368-372.*
33. Yadav D 2009. *Ethnoveternary plants from tribes in habited localitiesof Ratlam District Madhya Pradesh, India. Indian J. Trad.Knowledge, 33:64-67.*



# EASIER (EXECUTABLE ACCESS TO STATISTICS FOR INTERACTIVE AND EFFICIENT RESEARCH)

<sup>1</sup>Ferdie S. Ching, <sup>2</sup>Dr. Merilyn D. Juacalla

<sup>1</sup>Faculty, Lowland Integrated National High School

<sup>2</sup>Associate Professor V, Laguna State Polytechnic University, Santa Cruz, Laguna, Philippines

Article DOI: <https://doi.org/10.36713/epra7462>

DOI No: 10.36713/epra7462

## ABSTRACT

*The purpose of the study is to develop a reliable computer-aided statistical instrument for data processing.*

*The researcher come up to the idea to formulate an executable program running in Microsoft Excel platform. The platform is chosen based on the fact that it is widely used office application and known to be user-friendly. EASIER or Executable Access to Statistics for Interactive and Efficient Research was born. Executable because the program can be run by a computer, it is accessible in terms that most teachers use MS Excel as an office application, it can solve and analyze most statistics problems, interactive because there is a two-way flow of information between a computer and the user which respond to a certain input, the system promise to achieve a maximum productivity with a minimum wasted effort or expense, and to establish facts and reach new conclusions.*

*The statistical instrument was evaluated by twenty-four (24) Senior High School Teachers from Nagcarlan, Liliw, Majayjay, Magdalena, Pila, Victoria, and Sta. Cruz district and six (6) College Teachers from Laguna State Polytechnic University Sta. Cruz Main Campus, and from Philippine Women's University Sta. Cruz, Laguna.*

*It sought to answer the following questions: (1). What is the mean level of basic requirements of using computer-aided statistical instrument in terms of: 1.1 knowledge, 1.2 software and 1.3 hardware.? (2). What is the mean level of capability of EASIER as a computer-aided statistical instrument in computing statistical problems in terms of: 2.1 accepting input and data parameters, 2.2 organizing data, and 2.3 generating result, figures, charts, and drawing conclusion? (3). What is the mean level of acceptability of EASIER as a computer-aided statistical instrument in statistical analysis in terms of; 3.1 tool interface, and 3.2 operation and function? (4). Is there a significant difference between the level of responses of teachers from Senior High School and College instructors in terms of capability and acceptability of EASIER as a computer-aided statistical instrument?*

*The teacher respondents tested and evaluated EASIER based on the survey questionnaire. Weighted mean and standard deviation were used to measure the mean level requirement of using computer-aided statistical instrument and the mean level capability and acceptability of EASIER as candidate to be one of the computer-aided statistical instruments.*

*The statistical data reveal the following findings:*

*The level of requirements in terms of knowledge, software, and hardware got an overall mean of 4.81, 4.83, and 4.75 respectively, which are stated to be "Completely Required". This means that even there is a powerful computer-aided statistical instrument, certain amount of knowledge is required to deal with data analysis. (2.) The level of capability of EASIER in terms of accepting input and data parameters, organizing data, and generating result, figures, charts, and drawing conclusion showed "Very High Capability" with overall mean of 4.84, 4.76, and 4.90 respectively. These gathered means indicate that EASIER can perform data analysis at high level and capable of managing data according to the ways no other available instrument can, especially in generating conclusions. (3.) The level of acceptability of EASIER in terms of tool interface, and operations and functions are "Acceptable" with an overall mean of 4.86 and 4.89. This shows that aside from being a powerful computer-aided statistical instrument, EASIER appears to be appealing to respondents on how it looks and how it handles data. EASIER is also reliable and dependable instrument for data analysis through real-time and accurate computation. Further, EASIER can be innovated at some point making it better and updated. (4.) The difference between how Senior High School Teachers and College Teachers perceive EASIER is "Not Significant". Meaning, though these teachers treat Statistics and Probability at different level, and with the manner they use different available statistical instrument, EASIER is accepted to be a powerful computer-aided statistical instrument.*



## INTRODUCTION

“Human needs never end”, in desperation to satisfy all demands increase; inventions, creations, and formulations also rises. People accustoms to adapt to new things as their desire and wants increases each day. When people encountered difficulties, they usually think of solutions to overcome those challenges. Here comes the role of research, which may result in the development and advancement of society specially in the field of information and communications where computer-aided design and computing are very evident and imminent.

Statistics as a body of science that collects, analyzes, interprets, and presents data starting from a population down to an acceptable number of samples plays important role in research. Statistics involves crucial method behind how people make discoveries, make decision based on gathered data, and construct predictions. The mathematical foundation of modern statistics was established with the development of the probability in which in turn laid the foundation of inferential statistics.

Inferential statistics allow researchers to make predictions or inferences from available data. With this, researcher take data from samples and make generalizations about a population. Inference is a really difficult concepts and is the only key to inferential statistics. It is usually involved with a large amount of data that necessitates skills on the part of the researcher.

Inferential analysis, which is the hardest part gives meaning to a lifeless data and is a very integral part of any research because it showcases important details from the hypotheses down to conclusion based on the assumptions, computations, differentiation, and seeking relations between two or more groups. Most researchers find this part as difficult and challenging because, it poses a different level of knowledge to cope with the numerical results. Researchers often seek the help of a mathematics practitioner which somehow form additional task and challenges.

This research study proposes a computer-aided statistical instrument that would help to alleviate the difficulties encountered by researchers in terms of data processing.

## RESEARCH METHODOLOGY

### Research Design

The study aimed to design and develop a computer-aided statistical instrument to help teachers in doing action research and provide a reliable instructional material.

The study employed both descriptive and experimental method of research. Descriptive research narrates a population, situation or phenomenon that is being studied focuses in dealing and answering how, what, when and where questions. Descriptive research also involves collecting data in order to answer questions regarding the study about current status of the subject or prevailing conditions. (Lambert, 2012). Survey questionnaire were given and distributed through Google Forms after the study was shown to each respondent through face-to-face, Google Meet and recorded video presentation to determine the acceptability of EASIER with respect to its basic requirements, how it accepts inputs and data parameters, data organization, generating results, tool interface, and operations and functions. The experimental part is to determine the difference between the replies of the two groups of respondents form out of thirty Senior High School teachers and collegiate teachers. This will indicate how EASIER will be accepted from two major departments where Statistics and Probability is being taught.

### Respondents of the Study

The respondents of the study were selected by purposive sampling. Twenty-four (24) senior high school math teachers handling Statistics and Probability for Grade 11 from the district of Nagcarlan, Liliw, Majayjay, Magdalena, Pila, Victoria, and Santa Cruz, and six (6) college math teachers handling Advanced Statistics and Probability from Laguna State University (LSPU) Main Campus and Liliw Extension and Philippine Women’s University Santa Cruz, Laguna (PWU-CDCEC) were chosen. The coverage area of the study seems very large considering the number of mathematics teacher available with a maximum of at least two (2) per school who handle Statistics and Probability.

### Sampling Techniques

The teachers were selected using purposive sampling technique. This technique was used to ensure that out of mathematics teachers available per area, teachers who only handle statistics and probability will be selected. As stated by (Crossman, 2017) purposive sample is a non-probability sample that is selected based on characteristics of a population and the objective of the study. The sampling unit will be based on the subjective judgement of the researcher.

### The Research Procedure

Series of methodologies and procedures were followed to evaluate EASIER as a reliable and acceptable computer-aided statistical instrument.

## Stage 1 – Programming of EASIER



The researcher who is equipped with Mathematical and Information Technology expertise made the content of EASIER. With a high level of logical thinking, formulas and function were combined so as to create a

powerful computer-aided statistical instrument. Series of problems from the web and personal research were used to test for its accuracy and reliability. It is one-whole year in the making.

## Stage 2 – Validation of EASIER

With the approval of the thesis adviser and assurance of the Statistician with the survey questionnaires, the researcher sought the permission of the DepEd-Division Office and principals to conduct the study within the district of Nagcarlan, Liliw, Majayjay, Magdalena, Pila, Victoria and Sta. Cruz. EASIER was presented to thirty (30) selected Senior High School Teachers and College Instructors. Statistics problem were given to respondents, each will be computed using MS Excel Data Analysis and EASIER. Answers from the two computer-aided statistical instruments are compared for consistency.

This study was conducted during the first semestral of Academic Year 2020-2021 in Nagcarlan, Liliw, Majayjay, Magdalena, Pila, Victoria, and Santa Cruz District.

Problem was identified, analyzed, constructed, and presented to the panel of experts and was approved. Statement of the problem, hypotheses, theoretical framework, conceptual framework, and literature related to the study were developed and presented for review.

With the help of a self-made instrument which was validated by the panel of experts, survey was initiated from the purposively chosen respondents and data were collected.

Data are then organized and analyzed. The level of requirements, level of capability and level of

acceptability was calculated using mean and standard deviation.

Finally, conclusions are drawn from the derived statistically treated result.

### The Research Instrument

The researcher formulated and developed the content of EASIER based from mathematical principle along with Statistics and Probability. Inferential Statistics problem were given to the respondents to test the accuracy of EASIER based on the premise that it will generate necessary requirements of the quantitative research limited to hypotheses, decision rule, computed value, effect size, post-hoc, and conclusion. Using the data gathered from the respondent's groups Senior High School teachers and College Teachers, the mean level of basic requirements, level of capability and level of acceptability were computed and concluded. The difference between the response of the two groups are compared to determine the level of accuracy and reliability of EASIER.

### Statistical Treatment of Data

To answer a valid and reliable presentation, analysis and interpretation of the problem, the following statistical treatment were used.

**Table 1. Statistical Treatment**

Statement of the Problem	Statistical Treatment
To determine the level of basic requirements of EASIER in terms of knowledge, software, and hardware.	Mean and Standard Deviation
To determine the level of capability of EASIER in terms of accepting inputs and data parameters, organizing data, and generating results, figures, charts, and conclusion.	Mean and Standard Deviation
To determine the level of acceptability of EASIER in terms of tool interface, and operations and functions.	Mean and Standard Deviation
To determine the significant difference of the level of responses between Senior High School Teachers and College Teachers	T-test for uncorrelated Samples





The results of the responses were collected using Google Form in which results are already tallied. Mean and standard deviation were computed to determine the level of basic requirements, level of capability and level of acceptability.

Uncorrelated sample T-test was used to compare and determine the difference between the level of responses of the two respondent's group, the Senior High School Teachers and College Teachers. A p-value is also computed to support the test to note if the probability of the results of the sample data occurred by chance.

## RESULTS AND DISCUSSIONS

The level of required framework, capability and acceptability of EASIER was evaluated based on knowledge requirements, software requirements, hardware requirements, accepting inputs and data parameters, organizing data, generating results, figures, charts, and conclusions, tool Interface, and operations and functions.

Table 1 shows the teachers' evaluation on the level of required framework of using computer-aided statistical instrument based on knowledge.

**Table 1. Knowledge Requirements**

Knowledge Requirements	Mean	S.D.	Verbal Interpretation
1. Researchers should have basic knowledge in operating computer and other digital devices.	4.83	0.46	<i>Completely Required</i>
2. Researchers should have basic knowledge in statistical analysis.	4.87	0.43	<i>Completely Required</i>
3. Researchers should know how to manipulate data meaningfully.	4.87	0.43	<i>Completely Required</i>
4. Researchers should have basic knowledge in Microsoft Excel.	4.80	0.48	<i>Completely Required</i>
5. Researchers should have knowledge in exporting MS Excel into another format.	4.67	0.61	<i>Completely Required</i>
<b>Overall Mean</b>	<b>4.81</b>		<b><i>Completely Required</i></b>

Legend:

4.20 – 5.00 *Completely Required (CR)*

3.20 – 4.19 *Considerably Required (CoR)*

2.40 – 3.19 *Moderately Required (MR)*

1.80 – 2.39 *Slightly Required (SR)*

1.00 – 1.79 *Not at All Required (NR)*

The teachers strongly believe that knowledge in statistics play important role in using computer aided statistical instrument like EASIER, that basic knowledge in computer and other digital devices is required (M=4.83, sd=0.46), basic knowledge in statistical analysis (M=4.87, sd=0.43), manipulating data meaningfully (M=4.87, sd=0.43), basic knowledge in MS Excel (M=4.80, sd=0.48), and knowledge in exporting MS Excel into another format (M=4.67, sd=0.61)

The overall mean of 4.81 indicates that teachers strongly believe on having knowledge on

statistics, computer operations, and computer applications are requirements in using computer-aided statistical instrument. This means that although computer-aided statistical instruments are widely available on the market or over the internet, researchers should always have basic knowledge on statistical analysis (Gal 2002), digital devices and some basic applications running on it to perform data analysis.

Table 2 shows the teachers' evaluation on the level of required framework in using computer-aided statistical instrument as a software for data analysis.

**Table 2. Software Requirements**

Software Requirements	Mean	S.D.	Verbal Interpretation
1. Researchers may rely on computer aided statistical instrument to work faster and efficient.	4.77	0.43	<i>Completely Required</i>
2. Researchers with less mathematical background may rely deeply to computer aided statistical instrument.	4.67	0.48	<i>Completely Required</i>
3. Computer aided statistical instrument must provide better execution and mobility.	4.90	0.31	<i>Completely Required</i>
4. Computer aided statistical instrument must provide convenience on the part of the researcher on quantifying lifeless data.	4.90	0.31	<i>Completely Required</i>
5. Computer aided statistical instrument must be reliable and dependable.	4.93	0.25	<i>Completely Required</i>
<b>Overall Mean</b>	<b>4.83</b>	<b><i>Completely Required</i></b>	

**Legend:**

- 4.20 – 5.00 *Completely Required (CR)*  
 3.20 – 4.19 *Considerably Required (CoR)*  
 2.40 – 3.19 *Moderately Required (MR)*  
 1.80 – 2.39 *Slightly Required (SR)*  
 1.00 – 1.79 *Not at All Required (NR)*

Teachers also believe that relying on computer aided statistical instrument can make computing faster and efficient (M=4.77, sd=0.43), researchers from other field may rely on computer aided statistical instrument (M=4.67, sd=0.48), computer aided statistical instrument must provided better execution and mobility (M=4.90, sd=0.31), computer aided statistical instrument can be used conveniently (M=4.90, sd=0.31), and computer aided statistical instrument must be reliable and dependable (M=4.93, sd=0.25)

The overall mean of 4.83 suggests the importance of having a reliable and dependable computer aided statistical instrument in the form of spreadsheet like EASIER in dealing with lifeless data

for a meaningful analysis. Researchers outside the field of mathematics may rely deeply to computer aided statistical instrument to cater their thirst for data manipulation requirements. However, the computer-aided statistical instrument must supply most of the required figures and results for beginners and non-mathematically inclined individual to follow. As mentioned by McGill (2015) spreadsheet knowledge shows to be important in influencing the quality of the system being developed and acts directly upon the individual impact of the application.

Table 3 shows the teachers' evaluation on the level of required framework of using computer-aided statistical instrument based on hardware.

**Table 3. Hardware Requirements**

Hardware Requirements	Mean	S.D.	Verbal Interpretation
1. Computer aided statistical instrument must meet minimum hardware requirement to cater major type of users.	4.87	0.35	<i>Completely Required</i>
2. Offline computer aided statistical instrument provides faster execution in a more convenient way.	4.60	0.86	<i>Completely Required</i>
3. Computer aided statistical instrument must be compatible in a variety of digital devices for convenience and mobility.	4.87	0.35	<i>Completely Required</i>
4. Computer aided statistical instrument should provide option for printing to output organized results.	4.73	0.52	<i>Completely Required</i>
5. Computer aided statistical instrument must be accessible by multiple users through local area network.	4.67	0.66	<i>Completely Required</i>
<b>Overall Mean</b>	<b>4.75</b>	<b><i>Completely Required</i></b>	



*Legend:*

- 4.20 – 5.00 *Completely Required (CR)*  
 3.20 – 4.19 *Considerably Required (CoR)*  
 2.40 – 3.19 *Moderately Required (MR)*  
 1.80 – 2.39 *Slightly Required (SR)*  
 1.00 – 1.79 *Not at All Required (NR)*

Hardware is also a part of computer aided statistical instrument requirements that teachers believe that the instrument must run at a minimum hardware parameter (M=4.87, sd=0.35), having reliable offline instrument is more convenient (M=4.60, sd=0.86), the statistical instrument is compatible with a variety of digital devices (M=4.87, sd=0.35), the statistical instrument can output hard copies of organized results (M=4.73, sd=0.52), and the statistical instrument must be accessible by multiple user for sharing (M=4.67, sd=0.66)

The overall mean of 4.75 indicates that hardware must coincide with computer aided statistical

instrument like EASIER to produce desirable results. Heavy computing applications relies on sufficient hardware requirement to work faster and to prevent computers to freeze. Though EASIER can be accomplished with a minimum hardware requirement, fast data processing can be done in new and high computer's architecture as elaborated by Ailamaki, (2015).

Table 4 shows the teachers' evaluation on the level of capability of EASIER based on accepting inputs and data parameters.

**Table 4. Accepting Inputs and Data Parameters**

Accepting Inputs and Data Parameters	Mean	S.D.	Verbal Interpretation
1. The instrument provides a wide range of statistical tool and data analysis.	4.70	0.53	<i>Very High Capability</i>
2. Statistical tools can be easily selected and directed to the statistical operation.	4.90	0.31	<i>Very High Capability</i>
3. There are enough cells provided for the inputs.	4.77	0.50	<i>Very High Capability</i>
4. The instrument provides different alpha or significant levels.	4.93	0.25	<i>Very High Capability</i>
5. The instrument is capable of displaying one-tailed and two-tailed direction with corresponding critical values.	4.97	0.18	<i>Very High Capability</i>
<b>Overall Mean</b>	<b>4.85</b>		<b><i>Very High Capability</i></b>

*Legend:*

- 4.20 – 5.00 *Very High Capability (VC)*  
 3.20 – 4.19 *High Capability (HC)*  
 2.40 – 3.19 *Moderate Capability (MC)*  
 1.80 – 2.39 *Low Capability (LC)*  
 1.00 – 1.79 *Very Low Capability (VLC)*

With respect to the manner of how EASIER works, especially in accepting inputs and data parameters, teachers rated the capability of EASIER to be very high in terms of providing a wide range of statistical tool (M=4.70, sd=0.53), tools are very manageable (M=4.90, sd=0.31), slots for inputs are sufficient (M=4.77, sd=0.50), the instrument provides different alpha levels to choose from (M=4.93, sd=0.25) and directional and non-directional parameters are also available (M=4.97, sd=0.18).

With an overall mean of 4.85, this indicates that EASIER can accept enough inputs to cater

different researchers need in data organization and analysis. White et al (2003) stated that controlling the type of data or the values that users can enter into a cell is important to ensure that the process is an error-free as possible through data validation. Diverse statistical tools available within the computer-aided statistical instrument can fulfill larger area of data analysis to provide data maneuvers to researchers.

Table 5 shows the teachers' evaluation on the level of capability of EASIER based on organizing data.



Table 5. Organizing Data

Organizing Data	Mean	S.D.	Verbal Interpretation
1. The statistical instrument is designed with scientific and mathematical basis.	4.77	0.43	<i>Very High Capability</i>
2. The statistical instrument is easy to use for novice single user and for large groups and experts.	4.73	0.45	<i>Very High Capability</i>
3. The statistical instrument design includes a capability for reprocessing and error corrections.	4.77	0.50	<i>Very High Capability</i>
4. Access to the statistical instrument is practical and cost-effective.	4.77	0.50	<i>Very High Capability</i>
5. There are enough tables provided for data structure.	4.70	0.60	<i>Very High Capability</i>
6. Cells containing relevant formulas are kept protected.	4.70	0.53	<i>Very High Capability</i>
7. Steps in data analysis are presented in the instrument for proper execution of data.	4.80	0.48	<i>Very High Capability</i>
8. Decision rules are well presented	4.83	0.46	<i>Very High Capability</i>
9. The general conclusion provides sufficient amount of information.	4.73	0.58	<i>Very High Capability</i>
10. The general conclusion part is easily understood by users.	4.77	0.63	<i>Very High Capability</i>
<b>Overall Mean</b>	<b>4.76</b>		<b><i>Very High Capability</i></b>

Legend:

4.20 – 5.00 *Very High Capability (VC)*

3.20 – 4.19 *High Capability (HC)*

2.40 – 3.19 *Moderate Capability (MC)*

1.80 – 2.39 *Low Capability (LC)*

1.00 – 1.79 *Very Low Capability (VLC)*

Table 5 shows how EASIER organize data once required values are loaded to the instrument and how EASIER was designed to meet certain standards in terms of mathematical basis (M=4.77, sd=0.43), the instrument is designed to be used by novice single user or groups (M=4.73, sd=0.45), error can be managed (M=4.77, sd=0.50), access to the instrument is cost-effective (M=4.77, sd=0.50), table are provided to view data structure (M=4.70, sd=0.60), formulas are well protected (M=4.70, sd=0.53), steps can be viewed along with the process (M=4.80, sd=0.48), decision rules are presented (M=4.83, sd=0.46), generated conclusion contains enough information (M=4.73, 0.58), and conclusion can be easily understood (M=4.77, sd=0.63)

In terms of organizing data, an overall mean of 4.76 proves that EASIER handles data manageably, the process are well presented, and the generated results are easily understood by both mathematically and non-mathematically inclined individual. The designed and execution of EASIER are based on mathematical fact and processes. Consistency is the first rule in data organization which is seen on EASIER. Murrell (2003) stated that the practical law is that organizing data is presenting it in a way both humans and computer can understand.

Table 6 shows the teachers' evaluation on the level of capability of EASIER based on generating results, figures, charts, and conclusions.



**Table 6. Generating results, figures, charts, and conclusions**

Generating results, figures, charts, and conclusions	Mean	S.D.	Verbal Interpretation
1. Hypotheses are systematically generated both in words and in symbols	4.90	0.31	<i>Very High Capability</i>
2. Graphs are provided and interpreted for additional information	4.90	0.31	<i>Very High Capability</i>
3. The statistical instrument computes statistics value correctly	4.93	0.25	<i>Very High Capability</i>
4. The statistical instrument shows critical value according to the table	4.97	0.18	<i>Very High Capability</i>
5. Decision is provided upon the comparison of the critical values against the computed value	5.00	0.00	<i>Very High Capability</i>
6. P-values are accurately computed for additional support	4.93	0.25	<i>Very High Capability</i>
7. P-value is compared to the level of significance for decision	4.97	0.18	<i>Very High Capability</i>
8. Effect size is accurately computed to quantify the difference between two groups	4.77	0.50	<i>Very High Capability</i>
9. The statistical instrument generates conclusion correctly	4.80	0.41	<i>Very High Capability</i>
10. The general conclusion presents all gathered and computed values	4.80	0.41	<i>Very High Capability</i>
<b>Overall Mean</b>	<b>4.90</b>		<b><i>Very High Capability</i></b>

Legend:

- 4.20 – 5.00 *Very High Capability (VC)*
- 3.20 – 4.19 *High Capability (HC)*
- 2.40 – 3.19 *Moderate Capability (MC)*
- 1.80 – 2.39 *Low Capability (LC)*
- 1.00 – 1.79 *Very Low Capability (VLC)*

The capability of EASIER is not limited to how it organize data but more on how output are produce and presented to the users in terms of generating hypotheses in words and in symbol (M=4.90 sd=0.31), graphs are interpreted for addional information (M=4.90, sd=0.31), statistics value are computed correctly (M=4.93, sd=0.25), critical values are presented according to the table (M=4.97, sd=0.18), the statiscal value and critical value are comapared (M=5.00, sd=0.00), the level significance are computed correctly for additional support (M=4.93, sd=0.25), P-value is compared with alpha levels (M=4.97, sd=0.18), effect size is computed to show how signifant relationships or difference are (M=4.77, sd=0.50), the generated conclusion is correct (M=4.80, sd=0.41), and the generated conclusion provide necessary information (M=4.80, sd=0.41)

An overall mean of 4.90 sufficiently proves that EASIER can generate accurate results within the allowable range, graphs are available to show relationships status between variables clearly with interpretation, supports for decision are available, and hypotheses are well generated and concluded. The accuracy of the results using EASIER are done through experimentation whereby problems are being loaded for comparison after being solved and tested using other available statistical instrument, though Collopy (2002) states that from a theoretical point of view there is a problem as no single method can be designated as the best to perform badly in all accuracy measures. Further testing and application is suggested to measure its accuracy.

Table 7 shows the teachers' evaluation on the level of acceptability of EASIER based on tools interface or how it looks.





Table 7. Tool Interface

Tool Interface	Mean	S.D.	Verbal Interpretation
1. Introductory screen is interesting	4.83	0.38	Acceptable
2. Homepage resembles statistical tools and labels	4.87	0.35	Acceptable
3. Statistical tools are properly organized	4.90	0.31	Acceptable
4. Statistical tools are easily distinguished	4.90	0.31	Acceptable
5. Available statistical tools are sufficient for basic statistical analysis	4.87	0.35	Acceptable
6. The instrument has clear view, displaying readable words and numbers	4.87	0.35	Acceptable
7. Color's blending is pleasingly displayed	4.80	0.48	Acceptable
8. Buttons and arrows are available for easy operation and maneuvers	4.87	0.35	Acceptable
9. Input cells can be easily identified	4.87	0.35	Acceptable
10. The instrument shows relevant graphs and charts	4.87	0.35	Acceptable
11. Tables are well presented and organized	4.90	0.31	Acceptable
12. The computed statistics, alpha level, and p-values is presented in APA format	4.83	0.38	Acceptable
<b>Overall Mean</b>	<b>4.86</b>		<b>Acceptable</b>

Legend:

- 4.20 – 5.00 Acceptable (A)
- 3.20 – 4.19 Slightly Acceptable (SA)
- 2.40 – 3.19 Neutral (N)
- 1.80 – 2.39 Slightly Unacceptable (SUA)
- 1.00 – 1.79 Unacceptable (U)

Table 7 shows how EASIER appeals to the users in terms of how it looks based on introductory screen (M=4.83, sd=0.38), homepage provides available tools (M=4.87, sd=0.35), statistical tools are properly organized (M=4.90, sd=0.31), statistical tools are easily distinguished (M=4.90, sd=0.31), statistical tools available are sufficient (M=4.87, sd=0.35), displays are readable (M=4.87, sd=0.35), colors are pleasingly displayed (M=4.80, sd=0.48), directional; arrows are available for easy maneuvers (M=4.87, sd=0.35), input cells can be easily identified (M=4.87, sd=0.35), graphs and charts are available (M=4.87, sd=0.35), tables are well presented and organized (M=4.90, sd=0.31), and the presentation of output is in

APA format providing clarity to papers (M=4.83, sd=0.38)

The overall mean of 4.86 shows that the tool interface of EASIER is acceptable and appealing to respondents, color blending is pleasingly displayed, and words are readable. Ali Darejeh and Dalbir Singh (2003) states that commonalities were used to extract user interface design principles such as reducing the number of features, avoiding using computer terms, putting customization ability to font, color, and size and using appropriate graphical objects such as avatar or icon.

Table 8 shows the teachers' evaluation on the level of acceptability of EASIER based on operations and functions.



Table 8. Operations and Functions

Operations and Functions	Mean	S.D.	Verbal Interpretation
1. The statistical instrument is easy to use and user-friendly	4.93	0.25	Acceptable
2. The statistical instrument meets basic function relevant to statistical analysis	4.97	0.18	Acceptable
3. The statistical instrument can be used offline making it more interactive	4.90	0.31	Acceptable
4. The statistical instrument can be easily programmed to adopt to certain issues and corrections	4.77	0.50	Acceptable
5. Computing is real-time; tables, charts and figures are adoptive to inputs	4.90	0.31	Acceptable
6. The statistical instrument is reliable, can be trusted as computing mechanism	4.93	0.25	Acceptable
7. The statistical instrument is compatible to major digital devices used by teachers	4.80	0.41	Acceptable
8. The statistical instrument performs accurately and at high speed	4.90	0.31	Acceptable
9. Continuous improvement from major types of users is vital	4.90	0.31	Acceptable
10. The statistical instrument can be innovated, making it better and updated	4.93	0.25	Acceptable
<b>Overall Mean</b>	<b>4.89</b>		<b>Acceptable</b>

*Legend:*

- 4.20 – 5.00 *Acceptable (A)*  
 3.20 – 4.19 *Slightly Acceptable (SA)*  
 2.40 – 3.19 *Neutral (N)*  
 1.80 – 2.39 *Slightly Unacceptable (SUA)*  
 1.00 – 1.79 *Unacceptable (U)*

Table 8 shows the condition of EASIER as an effective statistical instrument in terms of being user-friendly (M=4.93, sd=0.25), how Easier meets with basic function of statistical analysis (M=4.97, sd=0.18), being offline statistical solver making it more interactive to user (M=4.90, sd=0.31), EASIER can adopt to correction (M=4.77, sd=0.50), computing is real-time (M=4.90, sd=0.31), the statistical instrument is reliable (M=4.93, sd=0.25), EASIER is compatible with major digital devices (M=4.80, sd=0.41), EASIER performs at high speed (M=4.90, sd=0.31), improvements can be done by users (M=4.90, sd=0.31), and that EASIER can be innovated making it better and updated (M=4.93, sd=0.25).

The overall mean of 4.89 shows how EASIER is accepted by teachers as one of the available computer aided instrument that will provide reliable and dependable statistical results, analysis, and outputs. EASIER can also be innovated and improve to make it more powerful tool to cater parametric and non-parametric test. According to Reynolds, (2007), most programming systems which attempt to provide flexible and efficient data representations require the user to specify the range of variables, parameters, and function by extensive and detailed data structure declaration.



**Table 9. Difference between the responses of Senior High School Teachers and College Teachers**

Groups	Mean Score	Mean Difference	t-value	p-value	Remarks
SHS Teachers	4.86	0.12	1.229	0.229	Not Significant
College Teachers	4.74				

As shown in the table, SHS teachers registered a mean response of 4.86 while College teachers got a mean response of 4.74 with a mean difference of 0.12. The computed t-value of 1.229 was compared to its critical value for two-tailed direction and alpha of 0.5 to be 2.048 and was attested by a p-value of 0.229 which is higher than the threshold value.

These findings indicate that there was no significant difference between the responses of Senior High School Teachers and College Teachers in terms of accepting EASIER as a reliable computer-aided statistical instrument, that although they are dealing with Statistics and Probability at different level they look at EASIER as a competitive computer-aided statistical instrument to deal with data analysis applicable for conducting action research and as a teaching materials for senior high school and college students.

## CONCLUSION

From the result of the study the following conclusion was made:

The null hypothesis stating that there is no significant difference between the responses of teachers from Senior High School and College instructors in terms of capability and acceptability of EASIER as a computer-aided statistical instrument was accepted.

Based on the findings gathered from the analysis and interpretation of data, Senior High School Teachers and College Teachers treated EASIER the same way although they handle statistics and probability at different level. This means that EASIER can accommodate both senior high school and college level in terms of data manipulation and processing. EASIER was also accepted to be a reliable computer-aided statistical instrument based on the responses from the capability and acceptability level in terms of how it processes data and generate valuable results. Further, while EASIER is extremely useful, it was also revealed that certain amount of statistical and computer knowledge is required.

## RECOMMENDATION

Based on the results of the study and from the conclusion made, the following recommendation where hereby suggested:

(1). From the responses of the teachers surveyed, EASIER can be utilized as a powerful computer-aided statistical instrument to help teachers in dealing with inferential analysis in conducting action research. (2). Teachers can also use EASIER as an instructional material for checking statistical data analysis after manual calculation method are discussed to the students, this will further develop teachers and students' engagement specially during the time of pandemic where face-to-face interaction cannot be materialized. (3) Future researchers can further enhance EASIER by adding non-parametric test making it even more powerful computer-aided statistical instrument.

## REFERENCES

- Ailamaki, (2015)  
<https://dl.acm.org/doi/10.14778/2824032.2824142> Databases and hardware: the beginning and sequel of a beautiful friendship
- Anastasakis and N. Mort, (2011)  
[https://gmdhsoftware.com/GMDH\\_%20Anastasakis\\_and\\_Mort\\_2001.pdf](https://gmdhsoftware.com/GMDH_%20Anastasakis_and_Mort_2001.pdf)  
THE DEVELOPMENT OF SELF-ORGANIZATION TECHNIQUES IN MODELLING: A REVIEW OF THE GROUP METHOD OF DATA HANDLING (GMDH)
- Boem (2003)  
<https://ieeexplore.ieee.org/abstract/document/15418332005> International Symposium on Empirical Software Engineering
- Burns and Bozeman, (2011)  
<https://www.jstor.org/stable/44422672?seq=1> Computer Assisted Instruction and Mathematics Achievement
- Demiris et al. (2014)  
[https://www.researchgate.net/profile/AliDarejeh/publication/277589616\\_A\\_review\\_on\\_user\\_interface\\_design\\_principles\\_to\\_increase\\_software\\_usability\\_for\\_users\\_with\\_less\\_computer\\_literacy/links/556de9b008aec2268308be75/A-review-on-user-interface-design-principles-to-increase-software-usability-for-users-with-less-computer-literacy.pdf](https://www.researchgate.net/profile/AliDarejeh/publication/277589616_A_review_on_user_interface_design_principles_to_increase_software_usability_for_users_with_less_computer_literacy/links/556de9b008aec2268308be75/A-review-on-user-interface-design-principles-to-increase-software-usability-for-users-with-less-computer-literacy.pdf)
- Gal (2002)  
[https://www.stat.auckland.ac.nz/~iase/serj/SERJ11\(2\)\\_Bond.pdf](https://www.stat.auckland.ac.nz/~iase/serj/SERJ11(2)_Bond.pdf) Statistics as a pre-requisite in general education
- G.F. Williamson (2017)  
<https://ieeexplore.ieee.org/abstract/document/624340/authors#authors>



8. Goodman and Lundell (2015)  
[https://www.researchgate.net/profile/Ali-Darejeh/publication/277589616\\_A\\_review\\_on\\_user\\_interface\\_design\\_principles\\_to\\_increase\\_software\\_usability\\_for\\_users\\_with\\_less\\_computer\\_literacy/links/556de9b008aec2268308be75/A-review-on-user-interface-design-principles-to-increase-software-usability-for-users-with-less-computer-literacy.pdf](https://www.researchgate.net/profile/Ali-Darejeh/publication/277589616_A_review_on_user_interface_design_principles_to_increase_software_usability_for_users_with_less_computer_literacy/links/556de9b008aec2268308be75/A-review-on-user-interface-design-principles-to-increase-software-usability-for-users-with-less-computer-literacy.pdf)
9. Hoang Pham 2016  
[https://books.google.com.ph/books?hl=en&lr=&id=CVIHuH-O-NcC&oi=fnd&pg=PA1&dq=software+safety+and+reliability&ots=wZc1JHSrEu&sig=7AZIjSPw6e4j\\_jV6J\\_Clj\\_y50WY&redir\\_esc=y#v=onepage&q=software%20safety%20and%20reliability&f=false](https://books.google.com.ph/books?hl=en&lr=&id=CVIHuH-O-NcC&oi=fnd&pg=PA1&dq=software+safety+and+reliability&ots=wZc1JHSrEu&sig=7AZIjSPw6e4j_jV6J_Clj_y50WY&redir_esc=y#v=onepage&q=software%20safety%20and%20reliability&f=false)
10. Hoglund and G. McGraw (2014)  
<https://ieeexplore.ieee.org/abstract/document/1281254/references#references>
11. Karlsson and Ryan, (1997)  
[https://www.academia.edu/20305463/What\\_is\\_important\\_when\\_deciding\\_to\\_include\\_a\\_software\\_requirement\\_in\\_a\\_project\\_or\\_releaseimportant\\_when\\_deciding\\_to\\_include\\_a\\_software\\_requirement\\_in\\_a\\_project\\_or\\_release](https://www.academia.edu/20305463/What_is_important_when_deciding_to_include_a_software_requirement_in_a_project_or_releaseimportant_when_deciding_to_include_a_software_requirement_in_a_project_or_release)
12. Kinney and Robertson (2013)  
[https://digitalcommons.liberty.edu/cgi/viewcontent.cgi?referer=https://scholar.google.com/&httpsredir=1&article=1240&context=doctoralDiversity\\_of\\_developmental\\_students](https://digitalcommons.liberty.edu/cgi/viewcontent.cgi?referer=https://scholar.google.com/&httpsredir=1&article=1240&context=doctoralDiversity_of_developmental_students)
13. Mahmood, (2016)  
[https://digitalcommons.liberty.edu/cgi/viewcontent.cgi?referer=https://scholar.google.com/&httpsredir=1&article=1240&context=doctoralAdvantages\\_of\\_computer\\_over\\_human](https://digitalcommons.liberty.edu/cgi/viewcontent.cgi?referer=https://scholar.google.com/&httpsredir=1&article=1240&context=doctoralAdvantages_of_computer_over_human)
14. McGill, Tanya (2015)  
<https://www.sciencedirect.com/science/article/abs/pii/S016792360400003X> The role of spreadsheet knowledge in user-developed application success
15. Roschelle, Pea, Hoadley, Gordin, and Means, (2011)  
<https://digitalcommons.liberty.edu/cgi/viewcontent.cgi?referer=https://scholar.google.com/&httpsredir=1&article=1240&context=doctoral> Effective use of computers
16. SDM, (2015)  
<https://www.securedatamgt.com/blog/offsite-data-backup-companies/#:~:text=By%20keeping%20your%20data%20offline,data%20stored%20offline%20is%20removable,> Offsite Data Backup: A Secure Storage Solution
17. White et al. (2003)  
[https://www.tandfonline.com/doi/pdf/Darejeh, Ali and Singh, Dalbir \(2013\)https://www.researchgate.net/profile/AliDarejeh/publication/277589616\\_A\\_review\\_on\\_user\\_interface\\_design\\_principles\\_to\\_increase\\_software\\_usability\\_for\\_users\\_with\\_less\\_computer\\_literacy/links/556de9b008aec2268308be75/A-review-on-user-interface-design-principles-to-increase-software-usability-for-users-with-less-computer-literacy.pdf](https://www.tandfonline.com/doi/pdf/Darejeh, Ali and Singh, Dalbir (2013)https://www.researchgate.net/profile/AliDarejeh/publication/277589616_A_review_on_user_interface_design_principles_to_increase_software_usability_for_users_with_less_computer_literacy/links/556de9b008aec2268308be75/A-review-on-user-interface-design-principles-to-increase-software-usability-for-users-with-less-computer-literacy.pdf)
18. Yinghui Zhang (2016)  
<https://onlinelibrary.wiley.com/doi/epdf/10.1002/sec.1574>

## AUTHORS' PROFILE



**FERDIE S. CHING**, Teacher III at Department of Education - Lowland Integrated National High School, Maravilla, Nagcarlan, Laguna, Philippines, Senior High School Department. Backgrounds are Bachelor of Science in Electronics and Communication Engineering, Bachelor of Science in Computer Engineering, and Complete Academic Requirements leading to Master of Education Major in Mathematics.



**DR. MERILYN P. JUACALLA**, Associate Professor V, BS Math program Coordinator - College of Arts and Sciences, Laguna State Polytechnic University, Santa Cruz, Laguna, Philippines.



# A REVIEW ON MERGER OF COMMERCIAL BANKS IN INDIA: ITS IMPACT, PROS AND CONS

Dr. Sowmya Praveen K<sup>1</sup>, Dr. C.K. Hebbar<sup>2</sup>

<sup>1</sup>Post Doctoral Fellow in commerce, Srinivas University, Mangalore  
OrcidID: 0000-0002-1124-8488

<sup>2</sup>Research Professor, Srinivas University, Mangalore  
OrcidID: 0000-0002-3711-9246

## ABSTRACT

Majority of the Indian banking sectors face a main challenge of NPA's. Therefore, the Government of India, come up with the solution of merger of banks. Hence 2017 onwards merger of banks came into existence in the banking field. But, unfortunately merger of banks is not a new term. In India merger of banks began in the year 1960's. But it was popularized after 2017. In 2017, SBI merged with its five associated banks- State bank of Bikaner and Jaipur, SBM, SBT, State bank of Hyderabad, State bank of Patiala along with Bharatiya Mahila Bank. After that till 2021, many banks have merged. Hence this study was conducted to study the pros and cons of merger of banks, its impact on customers as well as employees and to know the different merger of banks.

**KEY WORDS:** Banks, Merger, Pros and cons, impact.

## 1.0 INTRODUCTION

Merger of banks started in India in the year 1960's. A Merger implies mix of two organizations into one organization. During the merger interaction, one organization endures and the other organization loses their corporate presence. To put it plainly, it's anything but a circumstance where, two banks pool their assets and liabilities to become one bank.

In the period of August 2019, the Finance Minister of India, MS Nirmala Sitaraman has reported to merger ten public area banks into four substances. The essential rationale behind this merger is to expand the worldwide seriousness of the Indian Banks. Presently the all-out public sector banks decreased to 12 from 27 out of 2017 in India.

Merger of banks will protect the financial system and depositor's money, since the merged banks will be more profitable and in better condition.

## 1.1 OBJECTIVES

The objectives of the study are as mentioned below:

- To know about merger of banks in India

- To highlight the usages from merger of banks
- To study the problems from merger of banks.

## 1.2 METHODOLOGY

This study is based on secondary data. The information's are collected from various peer reviewed journals, books, websites and magazines.

## 1.3 PURPOSE OF THE STUDY

In today's highly competitive business environment, banks and financial services play a very important role. In India there will be many PSU banks, Private sector banks, foreign banks and cooperative societies. Most of the people have account in more-than one bank. Even people get confuse to select the banks. In India, the major challenge faced by the banks, especially PSU banks are the NPA's. Hence government of India recommended to go for merger of banks. This makes me to study the concept of merger of commercial banks in India.

## 1.4 REVIEW OF LITERATURE

- Praveen S Kambar (2019): he states in this article that, the banking area is considered as





the help of an economy. The merger will assist the manages an account with improving operational proficiency and client administrations. This would include the cooperative energies in the branch organization, minimal expense stores and auxiliaries. In this paper the creator has attempted to look at the degree, suggestions and downsides of the consolidation interaction and furthermore to recognize the significant difficulties in its manner [1].

- Pardeep Kaur (2010): In this paper he inspects the effect of merger on the cost effectiveness of banks, that have been converged during post progression period. In this paper to test the effectiveness among private and public banks, both parametric and non-parametric tests are utilized. The discoveries of the examination recommends that, over the whole investigation period normal expense proficiency of public area banks discovered to be 73.4% and for private area banks is 76.3%. He additionally proposes that somewhat consolidation has been fruitful in Indian banking sector [2].
- Jaskaran Singh Madray (2020): this examination was attempted to dissect the conditions which lead to merger of public area banks and to investigate the impacts of merger on banking sector in India. The examination shows that, the merger of public

area banks was a required activity made by the public authority of India to reinforce the financial arrangement of the country and it will improve the NPA's and increment credit development of banks [3].

- Shabnam Nishat (2020): she accentuation in her article that, in arising economies like India M&A's assistance in supporting financial development, to contend with rivals, to grow business aboard and furthermore to increase market share. The examination uncovers that solitary converging of banks probably won't be productive for improving the effectiveness of the Indian PSU banks, rather than that staff of banks should invest genuine amounts of energy for improving their proficiency through better participation, understanding, proficient usage of the assets and carrying out better strategic decisions [4].
- Ishwarya J (2019), this paper looks at M&A's that have happened in Indian Banking sector. The paper analyses emerging trends and commends steps that banks should reflect for futures. The article compares pre- and post-merger financial performance of merged banks with the benefit of financial constraint. The results suggest that, M&A's have been effective in some extent for the Indian banking sector. The government should not encourage merger between strong and weaker banks [5].

**1.5 FOLLOWING IS THE LIST OF MERGERS OF PSU BANKS AFTER 2017**

Anchor bank	Amalgamated bank	Acquisition year
SBI	State bank of Bikaner and Jaipur, SBM, SBT, State bank of Hyderabad, State bank of Patiala along with Bharatiya Mahila Bank.	31 <sup>st</sup> March 2017
Canara Bank	Syndicate Bank	1 <sup>st</sup> April 2020
Union Bank of India	Corporation Bank, Andhra Bank	1 <sup>st</sup> April 2020
Bank of Baroda	Dena Bank, Vijaya Bank	1 <sup>st</sup> April 2019
Indian Bank	Allahabad Bank	1 <sup>st</sup> April 2020
Punjab National Bank	Oriental Bank of Commerce, United Bank of India	1 <sup>st</sup> April 2020

**1.6 THE BELOW MENTIONED TABLE SHOWS THE LIST OF DIFFERENT BENEFITS FROM MERGER OF PSU BANKS;**

Sl no	Benefits from merger of banks
1	Reduced operational risk
2	Higher scale of operations, resulting improved efficiency and lower cost
3	Improves the professional standard
4	Better efficiency ratio for operations
5	Helps to expand their coverage in regional areas
6	NPA is beneficial
7	Reduced financial risk
8	Increased opportunities
9	Reduced fee or charges
10	Availability of cheap loans
11	Economies of large scale



12	Development of rural areas, also increased growth and expansion
13	Better management of banking capital
14	Increased goodwill and market share
15	Helps to face competition
16	Improves customer base
17	Entry in the global market

### 1.7 LIST OF DRAWBACKS FROM MERGER OF PSU BANKS

Sl no	Drawbacks from merger
1	Have to bear the burden of weaker banks
2	Difficult to manage the people and culture of different banks
3	Chances of bank going bankrupt
4	No past experience
5	Risk of fraud and robberies
6	Risk of public debt
7	Strict assessment
8	Governance issues
9	Need of collateral
10	Complications

### 1.8 IMPACT OF MERGER OF COMMERCIAL BANKS ON CUSTOMERS

- The Account holders may get another account number and client ID. So, they can get official hint on allotment of new accounts right away.
- The account holders can utilize the remaining cheque book leaves for the period of 6-12 months.
- Account holders should be furnished with new SIP enlistment and command structures, where there is a programmed charge for SIP. A similar method must be followed for advance EMI's.
- Account holders of the merged bank, should refresh their new IFSC code.
- The clients of the merged bank can use their old passbooks, till it wraps up.

### 1.9 IMPACT OF MERGER OF COMMERCIAL BANK ON EMPLOYEES

After the merger, the employees of the bank may not lose their employment as guaranteed by the government. The employees have to work with the new work environment, new staffs, new locations. Most of the employees get transfer to other branches. The merged bank will provide all the basic facilities which they use to get from their existing bank.

### 1.10 IMPACT OF MERGER OF COMMERCIAL BANK ON COVID-19 PANDEMIC

The main reason of merger of PSU banks is to reduce the NPA's and expand the credit flow in the economy. But due to the effect of Covid-19, the Indian economy is facing a financial crisis. Which affects all the sectors like industry,

farming, business, education and so on. Thus, pandemic has put break for all merger related activities. The true intention of the merger will be possible only after the pandemic.

### 1.11 SUGGESTIONS

The suggestions of the study are as follows;

- Due to merger of banks, most of the old staffs have shifted to other branches, which affects the customer services. Hence proper service is very important.
- Most of the clients finds the difficulty of server problems, when the banks started the process of merger. Therefore, the bank should give more emphasis on server related issues.

### 1.12 CONCLUSIONS

Mergers are important for the growth and expansion of the public sector banks. Most of the bank have the burden huge NPA's. To safeguards the banks from the problem of NPA's, government has come up with the idea of merger. This will also help the economic growth of the country. Due to the merger of banks, the bank networks will increase and they will have a branch in regional areas. This helps the increased credit flows in the village areas and hence Indian economy will improve.

### REFERENCE

1. Kamar, P. S. (2019). A study on the consolidation and merger of public sector banks (PSB) in India: Issues and challenges. *International Journal of Social Science and Economic Research*, 4(6), 4326-4334.



2. KAUR, B. P., & Kaur, G. (2010). *Impact of mergers on the cost efficiency of Indian commercial banks*. *Eurasian Journal of Business and Economics*, 3(5), 27-50.
3. Madray, J. S. (2020). *Merger of Public Sector Undertaking Banks in India*.
4. Nishat, S., & Khan, L. (2020). *The Impact of Mega Mergers on the Efficiency of Indian PSU Banks*. *IUP Journal of Business Strategy*, 17(2), 21-33.
5. Ishwarya, J. (2019). *A Study on Mergers and Acquisition of Banks and a Case Study on SBI and its Associates*. *International Journal of Trend in Research and Development*, September, 22, 26.
6. MOHAN, L. (2021). *A STUDY ON MEGA MRGING IN INDIAN BANKING SECTOR: ITS IMPACT ON EMPLOYEES AND CUSTOMERS*. *S. Finance, Banking and Insurance*, 70.
7. Pozzolo, A. F. (2009). *Bank cross-border mergers and acquisitions: causes, consequences, and recent trends*. In *The Changing Geography of Banking and Finance* (pp. 155-183). Springer, Boston, MA.
8. Hindvi, M. S. (2019). *Is the merger of public sector banks a panacea for all the ills of banking industry*. *The Social ION*, 8(1), 57-60.



# APPLYING STATISTICAL TOOLS TO STUDY FOCUSES ON CONSUMERS BUYING BEHAVIOUR TOWARDS ONLINE SHOPPING: WITH REFERENCE TO VIZIANAGARAM AND SRIKAKULAM DISTRICTS

**Dr. K Srinivas Rao**

*Assistant Professor, GITAM Institute of Management, GITAM Deemed to be University, Visakhapatnam*

## ABSTRACT

*The change in technological area all over the world has changed the concept of information and communication. Internet use for commercial purposes gave rise to the existence of the electronic commerce (e-commerce) phenomenon. Online shopping or e-shopping is a form of e-commerce which allows consumers to directly buy goods or services from a seller over the Internet using a web browser. The study focuses on consumers buying behaviour towards online shopping in Vizianagaram and Srikakulam Districts which are fast growing districts in Andhra Pradesh state. Questionnaire was used to collect the primary data from two districts in Semi urban and Urban areas. The sample size of the study was 250 and the sample design adopted was convenience sampling. To find out result some statistical tools will be used in this study to know buyer behaviour towards purchasing goods through online, this paper tried to find out the impact of online market towards purchase behaviour of consumers through statistical techniques and gives suggestions to improve the same.*

**KEYWORDS:** *Behaviour, Consumer, E-Commerce, Online shopping, Marketing,*

## INTRODUCTION

Before the World Wide Web was created, Michael Aldrich developed a system called Redifon's Office Revolution in March 1980, connecting sales companies, suppliers, and customers together. Companies were able to order supplies from suppliers and sell products to customers electronically, utilizing videotex technology. It is considered a major predecessor and influence on the development of online shopping as we know it today. In 1994, several years after the launching of the World Wide Web, online transaction systems, including banking and shopping, started emerging. The first shopping transactions were completed through NetMark and Internet Shopping Network in 1994, beginning the online shopping boom. Amazon.com and eBay launched their websites in 1995, offering online shopping options for customers. Many of the first online shopping websites utilized Intershop Online, an online shopping software system, developed in 1995 by Intershop Communications AG. The Intershop Online software allowed businesses to more easily add online shopping capabilities, or e-commerce, on their website, with secure transactions for their customers.

Internet has become increasingly significant as a marketing apparatus in recent years. It carries

opportunities for retailers to sell and communicate with their customers by an interactive and flexible medium. An online stage in businesses enables to promote items and services and ensure great customer service by enabling businesses to deal directly and reach out to a wider market. The use of the Internet as a marketing apparatus in business industry offers great benefits.

The benefits include correspondence, exchange and appropriation channel capacities. A website assumes an indispensable role in business marketing strategy as a channel for giving data about items and services. The nature of presentation and usefulness of the business content was the significant website.

Purchase of items and services on the Internet is known as online shopping. Online shopping has become increasingly famous, due to convenience (and often lower prices). Especially in the Christmas season, online shopping saves an individual the hassle of searching several stores and afterward holding up in long queues to purchase a specific item. Consumer purchasing behaviour is the entirety of a consumer's attitudes, preferences, intentions, and decisions regarding the consumer's behaviour in the marketplace when buying an item or service. The investigation of consumer behaviour



draws upon sociology disciplines of humanities, brain research, humanism, and economics<sup>3</sup>.

## REVIEW OF LITERATURE

**Ramesh, V, Jaunky, V.C., Lafleur, C,** Recent years, the idea of shopping online has become a necessity than an extravagance. The singularities of online shopping are sprouting considerably. The players of this tendency show that there is as yet a huge possible demand for these shopping trends. There are many contributing elements that are influencing these behaviours. This investigation intends to scrutinize the contributing elements that are persuading the customers and consumers to select online shopping in Mauritius. The sample size is from the respondents having exposure to online shopping or e-stores.

**Alnaseri, M., Örs, M., Sheker, M., Shakir, M., Muttar, A.K,** Increasing sales is the primary objective of any business. Previously, the sellers displayed their items, and the customer came to attempt to get it. Yet, after the new invention (the Internet), there is a new shopping stage called online shopping. Each society has its culture and specificities that change or influence their intentions. This research examined the Gulf States to discover the essential factors that affect their intentions to purchase from the Internet. Several variables were chosen in this examination. These variables were adopted through the results obtained through the underlying questionnaire published in the investigation network.

**Wang, H., Zhang, F., Wu, G., Zhao, J., Zhao, C., Cao, X.** In recent years, the scale of network marketing increase quickly. The remark data of customs after shopping will generally make comments on the nature of products. The data can provide uphold for online marketing stage, creation enterprises and market supervision departments. This paper proposes an affective registering method based on previous remarks of customs, which can make great use of remarks, yet additionally greatly reduce the trouble of discovering better items.

**Hendar, Sudarti, K., Rhemananda, H.** This paper expects to acquire an accurate understanding of consumer acceptance behaviour about m-shopping based on the variables that have been explored in the literature, and as determinant of

fulfilment and repurchase intention. This paper selected 200 m-shopping customers in Indonesia and examines the regression relationship between the dimension of perceived m-shopping customer and online customer fulfilment and repurchase intention. The discoveries showed that all perceived m-shopping components (ease of use, usefulness, enjoyment, and value) determine online customer fulfilment and further lead to repurchase intention. By examining diverse literature about perceived m-shopping.

## OBJECTIVES OF THE STUDY

1. To identify the most preferred online shopping sites
2. To find out the preferred product for purchase through online shopping
3. To analyse the consumer opinion on the risk involved in online shopping.

## RESEARCH METHODOLOGY

**Primary and Secondary Data:** The Researcher used Descriptive Research Design in this research. Essential Data's were collected utilizing questionnaire and Secondary information's were collected from diaries, books and websites. The collected information was edited, coded, classified and tabulated for investigation. The examining technique used by the researcher is convenience inspecting. Sample size taken for the examination is 250.

### Sample Area

To find out impact of consumer behaviour towards online shopping questionnaire has been distributed in semi urban and urban areas of Vizianagaram and Srikakulam Districts which are growing vastly in Andhra Pradesh state.

### Sample Size

To find impact of consumer behaviour towards online shopping questionnaire, we have taken 250 samples based on consumer power in both districts, samples have been taken from each district.

### Statistical tools

Here to find out consumer preference and opinion towards online shopping some of the statistical tools have been applied such as percentages, Mean, Standard Deviation and ranking





## DATA ANALYSIS & INTERPRETATIONS

**Table 1: Ranking of Products Purchased Through Online Shopping**

Online Products	N	Minimum	Maximum	Mean	Rank
Housewares	250	1	10	6.53	10
Clothes	250	1	10	4.47	2
Electronic products	250	1	10	3.43	1
Cosmetic & Jewelry	250	1	10	5.35	6
Gifts	250	1	10	5.68	7
Books	250	1	10	5.01	4
Music	250	1	10	4.74	3
Tickets	250	1	10	5.14	5
Food	250	1	10	6.09	8
Games	250	1	10	6.03	9

Sources: Primary Data

From the above table obviously electronic items rank 1 in online shopping and it is followed by clothes in the second position and Music in the third

position and houseware items are ranked tenth in online shopping.

**Table 2: Ranking of Online Shopping Sites**

Online Sites	N	Minimum	Maximum	Mean	Rank
Snapdeal.com	250	1	11	4.07	3
Bigbasket.com	250	1	11	8.05	11
Paytm.com	250	1	11	5.07	5
Amazon.in	250	1	11	3.03	1
Flipkart.com	250	1	11	3.15	2
Myntra.com	250	1	11	6.23	7
Shopclues.com	250	1	11	7.11	8
Pepperfry.com	250	1	11	7.63	10
Goodlife.com	250	1	11	7.25	9
Ebay.in	250	1	11	5.08	4
Jabong.com	250	1	11	6.01	6

Sources: Primary Data

From the above table it is inferred that Amazon.in is ranked first in online shopping sites by the respondents followed by Flipkart.com and

Snapdeal.com in the second and third position. Bigbasket.com is in the eleventh position in online shopping sites.

**Table 3: Consumers Opinion On Product Risk in Online Shopping**

Opinion Of Consumers On Product Risk In Online Shopping	Mean	Std. Deviation
Risk involved in exchange of product	3.17	1.324
I might receive malfunctioning merchandise	3.14	1.133
I might not get what I ordered through online shopping	3.20	1.253
I might get damaged product	3.21	1.290
It is hard to judge the quality of merchandise over Internet	3.28	1.175
I may not get after sale service	3.24	1.335

Sources: Primary Data

Result: From the table it is inferred that significant danger involved in danger in online shopping is the trouble to judge the nature of item through internet value with a mean value of 3.28 followed by trouble that may involve in benefiting after sale service with a mean value of 3.24, damaged

item with a mean value of 3.21, danger in not getting the item ordered through online with a mean value of 3.20, hazard involved in exchange of item with a mean value of 3.17 and receipt of breaking down merchandise with a mean value.



**Table 4: Descriptive Statistics On Consumers Opinion On Perceived Risk in Online Shopping**

Opinion Of Consumers On Perceived Risk In Online Shopping	Mean	Std. Deviation
I feel that my personal information given for transaction to the retailer may be compromised to 3rd party	3.04	1.280
I might get overcharged if I shop online as the retailer has my credit-card information	3.21	1.126
I feel that my credit-card details may be compromised and misused if I shop online	3.68	1.056

Sources: Primary Data

From the table it is inferred that hazard about credit card is the major perceived danger in online shopping with a mean value of 3.68, followed by over change that might be imposed

with a mean value of 3.21 and compromise of person data with outsider with a mean value of 3.04.

**Table 5: Descriptive Statistics On Consumer Opinion On Convenience Risk In Online Shopping**

Consumer Opinion On Convenience Risk In Online Shopping	Mean	Std. Deviation
If I shop online I cannot wait till the product arrives	3.45	1.086
I will have problem in returning product bought online	3.23	1.271
It is not easy to cancel orders when shop online	3.09	1.350
I feel that it will be difficult settling disputes when I shop online	2.81	1.414
Finding right product online is difficult	3.44	1.181
I cannot get to examine the product when I shop online	3.23	1.310

Sources: Primary Data

From the table it is inferred that anxiety till the item arrives is a significant main consideration in convenience hazard with a mean value of 3.45 followed by trouble in discovering right item online with a mean value of 3.44. Other subsequent components that contribute towards convenience danger in online shopping include that unrealistic to

examine item in online shopping with a mean value of 3.23, problem encountered in returning the item when purchased through online with a mean value of 3.23, trouble to cancel orders when shop online with a mean value of 3.09 and trouble to settle disputes when shopped online with a mean value of 2.81.

**Table 6: Descriptive Statistics On Non-Delivery Risk in Online Shopping**

Opinion Of Consumers On Non Delivery Risk In Online Shopping	Mean	Std. Deviation
I might not receive the product ordered online	3.32	1.032
I do not shop online because of non-availability of reliable & well-equipped shipper	3.40	1.069

From the table it is inferred that with regard to non - delivery hazard, non-accessibility of reliable and well-equipped shipper is the main consideration with a mean value of 3.40 followed by the way that they may not receive the item ordered online.

**FINDINGS OF THE STUDY**

- Electronic items are positioned number 1 in web based shopping and it is trailed by garments in the second position and Music in the third position concerning the items bought through internet shopping.

- Amazon.in is positioned first in web based shopping locales by the respondents followed by Flipkart.com and Snapdeal.com in the second and third position in favored internet shopping destinations.
- Major hazard associated with danger in web based shopping is the trouble to pass judgment on the nature of item through web an incentive with a mean estimation of 3.28 followed by trouble that may include in profiting after deal administration with a mean estimation of 3.24



- Risk about charge card is the major seen danger in web based shopping with a mean estimation of 3.68, trailed by cheat that might be forced with a mean estimation of 3.21.
- Anxiety till the item shows up is a significant central point in comfort hazard with a mean estimation of 3.45 followed by trouble in discovering right item online with a mean estimation of 3.44.
- With respect to non - conveyance hazard, non-accessibility of dependable and well-prepared transporter is the central point with a mean estimation of 3.40.

## DISCUSSIONS AND IMPLICATIONS

Web based retailing is a developing in a wonder way around the world. Numerous examinations have been led by different exploration researchers and academicians at public level and worldwide level by investigating different variables that influence purchasing conduct of online customers. Discoveries in this investigation add to understanding the idea of internet shopping and the danger that effects on clients' buy conduct. The discoveries can assist directors with bettering see how clients assess internet shopping danger and how they are performing on various measurements to distinguish potential zones that need improvement. Subsequently this stage gives chiefs a chance to make better impressions that may pass on administration nature of internet shopping to clients. Chiefs invest energy, exertion and regularly funds in planning the insides of their physical stores, the online supervisors ought to likewise offer significance to great inside plan in any event, for their online stores.

## REFERENCES

1. Alnaseri, M., Örs, M., Sheker, M., Shakir, M., Muttar, A.K. *Factors Affecting Online Shopping Intention Through Verified Webpages: A Case Study from the Gulf Region, Studies in Systems, Decision and Control, Volume 295, 2021, Pages 75-95*
2. Chung, K.-H., Shin, J.-I. *The antecedents and consequents of relationship quality in internet shopping (2010) Asia Pacific Journal of Marketing and Logistics, 22 (4), pp. 473-491. Cited 64 times. doi: 10.1108/13555851011090510.*
3. GN Mandala, S Sirisetti, *Influence of attributes of mutual funds on investment decision SMART Journal of Business Management Studies, Volume-16, Issue-1, Pages- 35-42, 2020.*
4. GN Mandala, R Kakkar - *A Study on Impact of Exchange Rate Factor on Indian Stock Market, Journal of Computational and Theoretical Nanoscience, 2019, Volume-16, Issue-4*
5. GN Mandala, *A study on impact of investors demographics towards preferences of mutual funds in north coastal Andhra Pradesh, 2018/9/4, Publisher: KLEF.*
6. GN Mandala, A Mohanty - *A Study on Demonetisation and Its Impact on Indian Economy, Journal of Computational and Theoretical Nanoscience, 2019, Volume: 16 , Issue- 4*
7. Gangu Naidu Mandala , Pallawi Baldeo Sangode , S. Anjani Devi , Venkata Ramakrishna Rao Gandreti , *"Problems and Constraints Faced by Farmers in Financing and Marketing of Agricultural Produce in India," Universal Journal of Accounting and Finance, Vol. 9, No. 2, pp. 139 - 144, 2021. DOI: 10.13189/ujaf.2021.090201.*
8. Gangu Naidu Mandala , Meenakshi Verma , Anuj Verma , Pushpanatham Arumugam , *"Service Quality of CRM: With Reference to Public and Private Banks in Nagpur City," Universal Journal of Accounting and Finance, Vol. 9, No. 2, pp. 191 - 196, 2021. DOI: 10.13189/ujaf.2021.090207.*
9. Hendar, Sudarti, K., Rhemanda, H. *Online customer's satisfaction on repurchase intention: role of mobile shopping perceived customer, Advances in Intelligent Systems and Computing, Volume 1194 AISC, 2021, Pages 444-453.*
10. Konuk, F.A. *The role of store image, perceived quality, trust and perceived value in predicting consumers' purchase intentions towards organic private label food (2018) Journal of Retailing and Consumer Services, 43, pp. 304-310. Cited 38 times. www.elsevier.com/inca/publications/store/3/0/4/4/6/doi: 10.1016/j.jretconser.2018.04.011.*
11. Liu, Z., Lei, S.-H., Guo, Y.-L., Zhou, Z.-A. *The interaction effect of online review language style and product type on consumers' purchase intentions (Open Access) (2020) Palgrave Communications, 6 (1), art. no. 11. Cited 2 times www.palgrave-journals.com/palcomms/ doi: 10.1057/s41599-020-0387-6.*
12. M Gangu Naidu, *A study of financial performance of reputed public bank in India during 2006 to 2010, Asia Pacific Journal of Marketing & Management Review, Volume: 1, Issue 3, Pages 82-101*
13. M. Gangu naidu, *Performance Analysis Of Tier 1 Nps Schemes For Government Employees, Tactful Management Research Journal, Volume-1, Issue- 12.*
14. Mandala, G. N., Verma, M., Verma, A., Sirisetti, S., & Gandreti, V. R. R. (2021). *The Influence of Agricultural Farmers' Entrepreneurial Behavior on the Business Performance of Dairy Farmers in Andhra Pradesh.*
15. *Perceived usefulness, perceived ease of use, and user acceptance of information technology (1989) MIS Quarterly: Management Information Systems, 13 (3), pp. 319-339. Cited 21780*



- times*.<http://misq.org/misq/downloads/> doi:  
10.2307/249008
16. Ramesh, V, Jaunky, V.C., Lafleur, C, Factor's persuading 'online shopping' behaviour in mauritius: Towards structural equation modelling, *Advances in Intelligent Systems and Computing Volume 1171, 2021, Pages 873-883 6th International Conference on Information System Design and Intelligent Applications, INDIA 2019; Visakhapatnam; India; 1 November 2019 through 2 November 2019; Code 243559.*
  17. Wang, H., Zhang, F., Wu, G., Zhao, J., Zhao, C., Cao, X. *Affective Computing Based on Remarks of Customs in Online Shopping Websites, Advances in Intelligent Systems and Computing Volume 1213 AISC, 2021, Pages 201-206.*
  18. Wu, L.-Y., Chen, K.-Y., Chen, P.-Y., Cheng, S.-L. *Perceived value, transaction cost, and repurchase-intention in online shopping: A relational exchange perspective (2014) Journal of Business Research, 67 (1), pp. 2768-2776. Cited 137 times. doi: 10.1016/j.jbusres.2012.09.007.*



# SHAKESPEARE CRITICISM; DR JOHNSON CONTRIBUTION TO SHAKESPEARE CRITICISM

**Mr. Krishnakant Patil**

Lecturer, Department of English, Kles Basavaprabhu Kore Arts, Science & Commerce College, Chikodi,  
Karnataka.

---

## ABSTRACT

*Dr Johnson's Preface to Shakespeare is an important contribution to English literature and criticism. Dr Johnson is a neo-classical writer, his comments of Shakespeare is unbiased and worthy on the whole. Johnson not only praises but also points out his defects. For Shakespeare he believes audience as great judges. Johnson's duty was to show Shakespeare under the sunshine of neo-classical taste. Johnson does this satisfactorily though in some instances he's not fully justified. Preface to Shakespeare opens with a tribute to Shakespeare's writing, which Johnson consider it long lasting value. Further he also made comments to the defects of Shakespeare. In this paper we will going to see how Dr Johnson criticises Shakespeare.*

**KEYWORDS** – Shakespeare, drama, puns, characterisation, nature

---

## INTRODUCTION

Samuel Johnson's criticism on preface to William Shakespeare has been looked at masterpiece to the English literary criticism. In this criticism Johnson sets out his important principles and appreciate Shakespeare for his "excellences" and "as well as defects of the works of Shakespeare. Johnsons many points treated as fundamental aspects of modern criticism; others give greater insight into Johnson's prejudices than into Shakespeare's genius. Johnson may be a true classicist in his concern with the universal instead of with the particular; the very best praise he bestows upon Shakespeare is to mention that his plays are "just representations of general nature." The dramatist has relied upon his knowledge of attribute, instead of on bizarre effects, for his success. Johnson concludes. It is for this reason that Shakespeare has outlived his century and reached the purpose at which his works are often judged solely on their own merits.

## JUST REPRESENTATION OF GENERAL NATURE

As per Johnson the essential requirement beauty and truthfulness found in the nature. He finds this plentiful in Shakespeare. Johnson says, "Shakespeare is especially writers a minimum of especially modern writers, the poet of nature; the poet that holds up to this

readers a faithful mirror of manners and of life. His characters aren't modified by the customs of particular places, unpractised by the remainder of the world; y t e peculiarities of studies or professions, which may operate but upon small numbers; or by the accidents of transient fashions or temporary opinions: they're the real progeny of common humanity, like the planet will always supply, and observation will always find." In other words, dr Johnson, heavily admired the universal quality in Shakespeare's plays.

## UNIVERSALITY OF SHAKESPEARE'S CHARACTERS

Dr Johnson continue on to praise the Shakespeare of characterisation. He says that his characters are on the base of general principles and thus the entire system of life is continued in motion.' The implication of the neo-classical creed—'Just representation of general nature'—is that attribute, nature, a minimum of the refined attribute, is perennial. It is due to this universality that the work of an excellent artist has an inventive appeal which continues through the ages. That is why Pope asserts that the Greek and Roman writers expressed the foremost exceptional way of emulating nature which therefore to repeat Homer or Virgil was to imitate nature realistically. Pope feels that the lads of ancient period weren't much different from the lads of his own





age, especially in terms of their poetic interest or aesthetic faculty. A poet's universality depends upon his being general or particular with regard to his treatment of characters, he focuses his attention on the common nature of men, their general traits, emotions, passions and manners of life which are to be found in men in the least times altogether countries.<sup>3</sup> This indispensable 'generality' of a poet is further stressed on by Johnson in his novel *Rasselas* he doesn't number the streaks of the tulip, or describe the various shades within the verdure of the forest. He is to exhibit in his portraits of nature such prominent and striking features as recall the primary to every mind, and must neglect the minute discriminations.

### THE THEME

The knowledge of general attribute enable Shakespeare to unveil the truths of life and enrich his plays "with practical axioms and domestic wisdom". Shakespeare was none of those who attached an excessive amount of of importance to the themes of affection with regard to their theme. Other dramatists who consider the subject of affection in their works become unjust, and violate the probability. Life is misrepresented by them and thus the language deprived. Love is simply one of the varied human emotions and to assign overlarge a significance thereto is unjustifiable. it's no considerable impact upon the totality of life. Consequently it's little operation within the dramas of Shakespeare who "caught his ideas from the living world and exhibited only what he saw before him. He knew that the opposite because it had been regular or exorbitant was a explanation for happiness of calamity." this is often often a shrewd observation. Johnson goes on to say that Shakespeare's plays are rendered in such how that even a private has enough material and knowledge to draw from them. Johnson was bold enough to differ from his characters. as an example , Dennis and Rymer didn't approve of Shakespeare's depiction of Menenius, a senator of Rome, as a buffoon, and Voltaire didn't approve of the Danish usurper (Claudius in Hamlet) being shown as a drunkard. t. Shakespeare's story may require a Roman senator or a king but he thinks only in terms of men and not particular individuals belonging to a selected time or place. And undoubtedly, there is no reason to suppose an individual cannot be a buffoon because he's a Roman senator.

### JOHNSON ON MINGLED DRAMA

Mingling was objected to by the neo-classicists who were, more or less, obstinate about the purity of genres. The critical trend at the time was to believe tragedy as an unadulterated genre by itself and comedy

as a completely separate genre by itself. However, Johnson justifies the mingling of the two on the thought of the neo-classical theory itself. Art meant to the neo-classicists a truthful depiction of human life; on this basis, one can justify Shakespeare's practice of blending comedy and tragedy, for such a mingling displays real attribute which "partakes of fantastic and evil, joy and sorrow, mingled with endless kind of proportion and in numerable modes of combination". Shakespeare's plays depict a world where all human actions have equal importance, where all types of citizenry are equally represented and where we see with none objection, the reveller hastening to his wine and thus the mourner burying his friend. during this way Johnson meets the objections of the neo-classical critics on their own ground.

### JOHNSON ON RULES AND DIDACTICISM

Johnson isn't bound by the neo-classical rules of criticism in his approach to varied other details of Shakespearean drama. Dr Johnson, perhaps unwittingly, points out a possible contradiction within the critical theory of his time. If literary criticism is based on adequate principles with regard to the connection between art and nature, an appeal from criticism to nature is nonsensical. Any rules concerning the apt mode of representation should flow that basic requirement and can not contradict it. But Johnson was particular about the didactic function in conjunction with the imitative one. The aim of a bit is to please and instruct its reader., Johnson admits that Shakespeare has not only shown attribute because it acts in real exigencies but because it would be found in trials to which it can't be said to be exposed. But, according to him, what Shakespeare lacks is that the moral purpose which he should have abided by in his plays. rather than keeping track of morality, Shakespeare "sacrifices virtue to convenience" and is "much more careful to please than to instruct." Johnson feels that Shakespeare is careless about awarding his vicious characters with sorrow and thus the great characters with happiness; instead, he dismisses them to chance. He carries all of them through wrong and right leaving them to figure by accidents. it's with regard to this aspect that Johnson is dissatisfied with Shakespeare's drama

### THE JOHNSON DILEMMA

Johnson insists that a poet should 'imitate' attribute as closely and accurately as possible. At an equivalent time he also insists that the poet need to draw the story in such how that it brings some moral instruction and delight to the reader. This is possible,



we know, as long as attribute were fundamentally noble and refined. Even Philip Sidney, who argued that poetry should be morally instructive, couldn't deny the very fact that attribute, being what it essentially is, doesn't convey an ethical lesson to the observer; therefore he averred that the poet should plan to make the planet better and new. Johnson must be conscious of the very fact that the important world is way from always rewarding good or being basically moralistic. It is very interesting to ascertain Johnson grappling together with his dilemma during a long note on Lear. There he says that a play during which the wicked prosper and therefore the virtuous are miserable may be a just representation of the common incidents and occurrences of life but since all folks love justice, a play won't go to pot by showing the ultimate victory of persecuted virtue; and if the pleasure we derive from 'poetic justice' may be a wholly separate quite pleasure from that of being instructed about attribute. Johnson only repeats the old theory that literature should be both pleasing and instructive if it's to be everlasting; he fails to explore all its implications.

### PUNS AND QUIBBLES.

Another weakness that Johnson points out at Shakespeare's plays is that Shakespeare is madly interested in word-play and equivocations. Johnson says during this connection: "A quibble was to him the fatal Cleopatra that he lost the planet and was content to lose it". This approach towards poetic diction is vital in both the idea and therefore the practice of poetry from Dryden to Johnson; its critical implications are most clearly visible in Johnson's Lives of the poets. However, we'd not be quite as vehement as Johnson is our condemnation of the penchant for puns in Shakespeare. We are more willing to ascertain it as an aberration of his times.

### JOHNSON AND THE UNITES

Dr Johnson admired Shakespeare unities of time and place. The neo classic period was not in the favour of accepting Shakespeare. Thus the drama had to be curtailed and brought under the prescribed framework and therefore the actual experience is nearly nullified. The proponent (those who introduced it) of this law held that any depiction differing from these rules isn't acceptable. But Shakespeare wasn't a slave to the normal etiquettes. Justifying him Johnson says that the action of those plays is predicated on certain conventions which the audience accepts readily. For example if the spectators can take it without any consideration that a specific actor on the stage is Caesar or Antony, the audience also can accept the convention of shifting scenes from one place to a different or the

passage of long periods of your time. But the truth is that the spectators are always in their senses, and know from the primary act to the last that the stage is merely a stage, which the players are only players (then) where is that the absurdity of allowing that space to represent first Athens, then Sicily, which was always known to be neither Sicily nor Athens, but a contemporary theatre?" True, this doesn't seem to be an absolutely original remark.

### REFERENCE

1. Lonsdale, Roger. "Samuel Johnson" Dryden to Johnson. Ed. John Hardy London: Sphere Books LTD, 1971. 279-311. Print
2. McGowan, Ian. The Restoration and Eighteenth Century. London: Macmillan Education LTD, 1989. Print. Lonsdale, R



# EFFECT OF USE OF INTERNET ON ADOLESCENTS MENTAL HEALTH DURING COVID-19

Ridhee Agarwal<sup>1</sup>, Navya Bajpai<sup>2</sup> and Mansi Patel<sup>3</sup>

Graduate Student, Department of Psychology, Banasthali Vidyapith, Jaipur, Rajasthan

\*Corresponding Author: Ridhee Agarwal

## ABSTRACT

**Background** - Covid-19 has caused profound changes in the way people communicate and interact. It is unclear, however, whether some of these changes may affect certain normal aspects of human behavior and cause Mental health problem. Several studies have indicated that the prolonged use of Internet usage such as surfing internet, gaming, social media is related to signs and symptoms of depression, anxiety and stress. In addition, some authors have indicated that Internet usage can be associated with low self-esteem and life satisfaction especially in children and adolescents. The relationship between internet use and mental problems to this day remains controversial, and research on this issue is faced with numerous challenges.

**Objective** - The objective of this study was to 1. assess how Internet usage is associated with Mental health during covid-19 in adolescents and 2. what is the effect of excessive internet usage on mental health during covid-19, when people are socially connected and are taking classes and spending their time surfing internet and gaming via internet.

**Methods** - A Qualitative study was conducted, online due to covid-19 circumstances with the help of questionnaire, among the adolescents. Total number of 100 adolescents were randomly selected. Internet Usage in covid-19 and Mental Health and covid-19 Questionnaire were used to measure Internet usage and the mental health correlates, respectively. Correlation was applied using SPSS software for testing the association of internet usage and the mental health issues.

**Results** - The response on Mental Health and covid-19 Questionnaire depicts that that on average most respondents have moderate effect on their mental health during covid-19. The mean and standard deviation was found to be 84.71 and 18.88 respectively. The response on Internet Usage in covid-19 Questionnaire depicts that on average respondents have high internet usage in covid-19. The mean and standard deviation was found to be 35.27 and 7.77 respectively. The correlation analysis was conducted using SPSS software and it was found that there is a positive correlation between internet usage and its effect on mental health in covid-19. The correlation is significant at the 0.001 level (2 tailed).

**Conclusion** - we can conclude from the above results that there is a association between internet usage in covid-19 and its effect on mental health among adolescents in covid-19 and excessive internet usage is thus, correlated with mental health problems. This means that Internet usage such as surfing internet, social media use, gaming etc. is correlated with psychological, social and emotional effect on mental health leading to depression, anxiety, stress, low self-esteem, low life satisfaction and less happiness in adolescent's life. Thus, it is very important for all of us to use internet wisely in order to make sure that it doesn't have a bad impact on mental health.

**KEYWORDS:** Internet usage, Mental health, Covid-19, Adolescents

## 1. INTRODUCTION

Mental health issues following the COVID-19 pandemic stem from 'normal' people being exposed to 'extraordinary situations'. The presentations are myriad, and include emotional difficulties like anxiety, depression, biological effects like sleep, appetite

disturbances as well as severe mental illness and substance misuse. For most, these symptoms are mild and transitory, but a minority may develop severe mental health issues that require additional mental health support. Children, elderly, pregnant women, people with pre-existing mental illness, people living alone and families of those who have died in the



COVID-19 pandemic may belong to this group.

Another important aspect is the psychological impact of the pandemic on the first response teams. The long hours working in potentially dangerous situations makes them particularly vulnerable. The widespread social and economic disruption of the pandemic has produced a psychosocial impact unheard of in modern times. All these have been further fueled by information overloads of new generation media platforms that have relentlessly spread a mix of accurate as well as inaccurate information and even conspiracy theories which in turn have had a psychological impact on the community. The mental health and psychosocial impact of COVID-19 has thus been far reaching (NIMHANS,2020).

## USE OF INTERNET DURING COVID-19 LOCKDOWN

We think that the psychological impact of this pandemic like stress and anxiety among the general population is also a grave concern. The fear resulting from the disease, and the consequences of lockdowns, stress and anxiety have been mounting, and these affect individuals, families and society as a whole. Especially vulnerable are individuals with pre-existing mental and physical health conditions, those lacking social support, and first responders and healthcare workers. In extreme cases, fear may contribute to fatal outcomes and suicide, including among individuals who thought they had contracted the virus even though autopsies showed they did not. Time spent at home has increased considerably for most individuals, which may lead to a reduction or loss of daily routine and structure. Psychoactive substance uses and other reinforcing behaviors such as gambling, video gaming,

TV series watching, using social media, watching pornography, or surfing the internet are often used to reduce stress and anxiety and/or to alleviate depressed mood. These potentially addictive

behaviors may help alleviate stresses of daily living (often reflected as “escapism”) and avoid problems and difficult thoughts. Although these behaviors typically constitute non-problematic (or perhaps even healthy) coping strategies, for a minority of individuals they can lead to reduced engagement in usual social interactions and other activities of daily living. As a result, the tendency to use such substances and engage in the aforementioned behaviors as putative coping strategies in crises like the COVID-19 pandemic increases considerably and may develop into habits that are difficult to break.

## 2. REVIEW OF LITERATURE

### A. *Social Effect On Adolescents Mental Health*

Social media could play an even more important role during the lockdown. They enable socialization and communication and they are learning opportunities, including for adolescents' access to information about their health (O'Keeffe et al. 2011). Social media use could be a positive factor in helping adolescents to maintain social interaction during lockdown. However, social media also are associated with adverse outcomes. According to a recent systematic literature review, time spent and investment in social media correlate with levels of depression, anxiety, and psychological distress (Keles et al., 2020). They may be associated with sleep problems (Barry et al., 2017). The use of ICT carries risks. While considered healthy when pursued in moderation and for meaningful purposes, excessive engagement in specific online activities such as gambling, viewing of pornography, video gaming, social media use, shopping may lead to severe problems and elevate the risk of disordered or addictive use. Disordered use of the internet generates marked distress and/or significant impairment in personal, family, social, educational, occupational, or other important areas of functioning. Therefore, keeping involvement in these behaviors at moderate and controlled levels, especially during the pandemic, is imperative. This is also important because the respective industries (e.g., gambling, gaming, pornography) may encourage their customers to spend longer periods of time engaging in these activities, such as by launching opportunistic marketing campaigns. Social media is known to be a source of social reinforcement and validation. This platform provides people with an opportunity to share ideas, interact socially, form relationships, draw attention of others and create social image (Kietzmann et al., 2011). During the current global crises when ‘social distancing’ has become a norm, over-engagement in social media has become a ‘psychological necessity’ thereby helping people to address their needs of human interaction and coping with the pandemic. Therefore, despite the precautionary guidelines of social distancing, it provides people a platform to remain socially connected and universalize distress caused by the current crisis. Apart from socialization, social media is also being used for academic and work-related purposes like conducting online lectures, webinars, meetings and ensuring work from home. One of the major advantages of social media is that it facilitates awareness and provides mental health support by making resources available to those facing distress caused by lockdown and to those who are





isolated as a result of being quarantined. With the help of this platform, data scientists and healthcare professionals have recently surfaced as social media influencers with the aim to mobilize people for taking proactive steps to deal with the crisis (The Economic Times, 2020). In the ongoing scenario, social media has become one of the major sources for updating information on COVID-19 for people. However, its irresponsible use poses the challenge of 'infodemics' i.e. a situation when 'misinformation' spreads rapidly thereby affecting thinking and subsequent behavior of people. Recently WHO had cautioned people against social media rumors which lead to panic, stigma and irrational behavior (WHO, 2020). Given the rise in usage of this media, it becomes necessary to address its association with mental health. The relationship between social media disorder and mental disorders becomes controversial which is attributable to diagnostic complications (Pantic, 2014). Research in the past has shown that compulsive usage of social media impacts physical and mental health including cardio metabolic health, sleep, affect, self-esteem, well-being and functioning, especially in adolescents (Turel et al., 2016; Cheng and Li, 2014; Van Rooij and Schoenmakers, 2013). In light of the present pandemic, mental health conditions are found to be associated with the amount of social media exposure. Sharing endless selfies and all your innermost thoughts on social media can create an unhealthy self-centeredness and distance you from real-life connections. A study at the University of Pennsylvania found that high usage of Facebook, Snapchat, and Instagram increases rather decreases feelings of loneliness. Conversely, the study found that reducing social media usage can actually make you feel less lonely and isolated and improve your overall wellbeing.

### ***B. Psychological Effect On Adolescents Mental Health***

The present consensus guidance focuses on the engagement with information and communications technology (ICT) in the time of the COVID-19 crisis. ICT is a "savior"; it contributes vitally to disseminating knowledge about the outbreak to wide sectors of the global population, to an extent not possible without such technology. Information flow is a key factor in fighting the pandemic (enabling individuals to have instant access to reliable information, while granting researcher with means for collaboration on a global scale in the race to develop a vaccine and efficient treatment strategies, for example). Working and studying remotely is possible due to the use of ICT. Keeping social contact remotely with friends/families

to reduce psychological impacts of isolation, providing access to entertainment and even materials guiding physical exercise (e.g., live streaming home fitness sessions) are realized through ICT and represent strategies recommended by the WHO.

However, the current period of pandemic and lockdown brings together several factors related to internet addiction. Internet addiction is characterized by excessive or poorly controlled preoccupations, urges, or behaviors regarding computer use and internet access that lead to impairment or distress (Shaw and Black, 2008). Among the explanatory models of internet addiction, studies suggest that internet addiction may be influenced by stressful and traumatic experiences (Cerniglia et al., 2017). Internet addiction is believed to be associated with online games and social applications (Kuss et al., 2013). Internet addiction is also associated with depression (Ha et al., 2007). Furthermore, adolescents receive a lot of information through social media, which are sometimes more direct and less contextualized than traditional media. During the COVID-19 pandemic, a lot of adolescents are monitoring the news (Oosterhoff and Palmer, 2020). However, they do not have the same skills as adults, their brain is still maturing towards adulthood (Murty et al., 2016). They have access in real-time to videos, photos, stories on all current topics, and related controversies. Adult guidance would be necessary to acquire analytical skills on this information.

It is well known to us and also resonated by research that 'internet addiction' is predominantly linked to increased social media or gaming activities (Van Rooij and Schoenmakers, 2013; Van Rooij and Prause, 2014). While DSM-5 (APA, 2013) and the stable version of ICD-11 (WHO, 2018) have identified 'Internet gaming disorder' (IGD) as a provisional disorder, social media disorder is still not acknowledged. Increasing research is advocating that social media disorder should be considered an addictive disorder just like IGD (Pantic, 2014; Ryan et al., 2014). According to the DSM-5, a person is diagnosed as having IGD if there is fulfilment of 5 (or more) of the 9 criteria (preoccupation, tolerance, withdrawal, persistence, escape, problems, deception, displacement, and conflict) during a period of 12 months. Since social media disorder and IGD both relate to internet use, researchers refer to nine IGD criterion of DSM-5 for constructing diagnostic tools and establishing internet / social media addiction (Regina et al., 2016; Van den Eijnden, 2016). Since COVID-19 outbreak began from end of 2019 and crossed international borders from the beginning of 2020, undeniably '12 months DSM 5 criterion' is not applicable. But it is difficult to say if five or more IGD





DSM-5 criteria are fulfilled by the excessive social media users. It comes with a word of caution that excessive social media usage is known to be highly addictive due to its psychological, social and neurobiological basis. During current pandemic, like many other uncertainties, it is unclear whether this compulsive use of social media is just a 'phase' and a coping mechanism or an indication of addictive behaviour having mental health implications. Hence, in terms of current research implications and management, it is imperative to keep the contextual issue of global pandemic in mind and differentiate between addictive and extremely involved behaviour. A study done at Duke University found that, on days they use technology more, at-risk adolescents experienced more conduct problems and higher ADHD symptoms compared to days they used technology less. On the flip side, the study also found that those same adolescents experienced less depression and anxiety on days they used technology more. Research coming out of the University of Gothenburg in Sweden found a link between heavy cell phone use in young adults and depressive symptoms. A team of Australian researchers conducted two studies and found that compulsive internet use by adolescents leads to poorer mental health. A Swansea University study found that heavy internet users experience psychological symptoms of withdrawal when they stop using. Human beings need face-to-face contact to be mentally healthy. Nothing reduces stress and boosts your mood faster or more effectively than eye-to-eye contact with someone who cares about you. The more you prioritize social media interaction over in person relationships, the more you're at risk for developing or exacerbating mood disorders such as anxiety and depression.

### C. *Emotional Effect On Adolescents Mental Health*

A University of Michigan study found that Facebook use led to a decrease in happiness and overall life satisfaction. One can feel Inadequacy about their life or appearance. Even if you know that images you're viewing on social media are manipulated, they can still make you feel insecure about how you look or what's going on in your own life. Similarly, we're all aware that other people tend to share just the highlights of their lives, rarely the low points that everyone experiences. But that doesn't lessen those feelings of envy and dissatisfaction when you're scrolling through a friend's airbrushed photos of their tropical beach holiday or reading about their exciting new promotion at work. FOMO has been around far longer than social media, sites such as Facebook and Instagram seem to exacerbate feelings that others are having more fun or

living better lives than you are. The idea that you're missing out on certain things can impact your self-esteem, trigger anxiety, and fuel even greater social media use. FOMO can compel you to pick up your phone every few minutes to check for updates, or compulsively respond to each and every alert—even if that means taking risks while you're driving, missing out on sleep at night, or prioritizing social media interaction over real world relationships. About 10 percent of teens report being bullied on social media and many other users are subjected to offensive comments. Socialmedia platforms such as Twitter can be hotspots for spreading hurtful rumors, lies, and abuse that can leave lasting emotional scars. Researchers found that teens who spent a lot of time in front of screen devices -- playing computer games, using more social media, texting and video chatting -- were less happy than those who invested time in non-screen activities like sports, reading newspapers and magazines, and face-to-face social interaction. The happiest teens used digital media for less than an hour per day. But after a daily hour of screen time, unhappiness rises steadily along with increasing screen time.

Happiness is not a warm phone, according to a new study exploring the link between adolescent life satisfaction and screen time. Life satisfaction is one of the several aspects of positive mental health. It refers to a cognitive, judgmental process. It is not a direct, verifiable experience, nor a known personal fact, but a cognitive product that involves a comparative process between the individual's current life situation and internalized standards, allowing respondents to use the information they subjectively deem relevant when evaluating their own lives. According to Diener, subjective well-being covers two main components: one affective including negative and positive emotions, and one cognitive; namely life satisfaction. Teens whose eyes are habitually glued to their smartphones are markedly unhappier, said study lead author and San Diego State University and professor of psychology Jean M. Twenge. W. Keith Campbell at the University of Georgia, crunched data from the Monitoring the Future (MtF) longitudinal study, a nationally representative survey of more than a million U.S. 8th-, 10th-, and 12thgraders. The survey asked students questions about how often they spent time on their phones, tablets and computers, as well as questions about their in-the-flesh social interactions and their overall happiness. On average, they found that teens who spent more time in front of screen devices -- playing computer games, using social media, texting and video chatting -- were less happy than those who



invested more time in non-screen activities like sports, reading newspapers and magazines, and face-to-face social interaction. Twenge believes this screen time is driving unhappiness rather than the other way around. "Although this study can't show causation, several other studies have shown that more social media use leads to unhappiness, but unhappiness does not lead to more social media use," said Twenge, author of "iGen: Why Today's Super-Connected Kids Are Growing Up Less Rebellious, More Tolerant, Less Happy -- And Completely Unprepared for Adulthood." Total screen abstinence doesn't lead to happiness either, Twenge found. The happiest teens used digital media a little less than an hour per day. But after a daily hour of screen time, unhappiness rises steadily along with increasing screen time, the researchers report today in the journal *Emotion*. "The key to digital media use and happiness is limited use," Twenge said. "Aim to spend no more than two hours a day on digital media, and try to increase the amount of time you spend seeing friends face-to-face and exercising --two activities reliably linked to greater happiness."

### 3. RESEARCH METHODOLOGY

#### OBJECTIVES

The present study has been conducted to fulfil the following objectives:

1. To know the effect of use of internet on mental health during covid -19 in India.
2. To explore the relationship between the internet usage and Mental Health in covid-19.

#### PARTICIPANTS

A total number of 100 participants between age group of 16-22 were randomly selected. Out of 100 participants 76.4 % participants were females and 23.6% participants were males. Among these, 78 responses that is 63.4 % were from students. The criteria for the selection of the samples was as follows: sample should be between age group of 16-22. It should be a adolescent who uses internet daily. It should be the one who is willing to participate in this study and is ready to give their few minutes out of their valuable time for the purpose of filling the questionnaire.

#### PROCEDURE

A Qualitative study was conducted among adolescents. Online test was conducted using google forms due to covid-19 pandemic. Two tools were used for the same purpose. The tool is a written device that a researcher assesses to collect the data. After careful and detailed review of literature the researcher prepared and

developed an Internet usage in covid-19 questionnaire and Mental health and covid-19 questionnaire as a tool for the present study. Content validity has been done by experts and modification was done based on suggestions. Reliability and validity of the tool was tested prior to the study. Thus, A structured and validated questionnaire, was used for data collection.

#### RESEARCH HYPOTHESIS

1. There is significant relationship between Mental Health and Internet Usage during pandemic situation
2. There is a significant relationship between Internet Usage and Mental Health among adolescents in covid-19.
3. There is a significant relationship between excessive internet usage in covid-19 and mental health among adolescents in covid-19.

#### DESCRIPTION OF TOOL

##### INTERNET USAGE IN COVID-19 QUESTIONNAIRE

##### SECTION A - Demographic Variables

It comprised of 3 items such as Gender, Age and Occupation.

##### SECTION B - QUESTIONNAIRE

It is a 10 item Questionnaire which was used to assess the use of internet in covid-19. The responses are based on 5 point Likert scale. The respondents were categorized in the following ways: - Respondents who scored above 30 were considered HIGH ON INTERNET USAGE that is these respondents higher scores indicate more Internet usage in covid-19. Respondents who scored above 20 and below 30 were considered MEDIUM ON INTERNET USAGE that is these respondents scores indicate moderate level of internet usage in covid -19. Respondents who scored above 10 and below 20 were considered LOW ON INTERNET USAGE that is these respondents low scores indicate low internet usage in covid-19.

##### MENTAL HEALTH AND COVID-19 QUESTIONNAIRE

##### SECTION A - Demographic Variables

It comprised of 3 items such as Gender, Age and Occupation.

##### SECTION B - QUESTIONNAIRE

It is a 30 item Questionnaire which was used to assess the Mental Health in covid-19. The responses



are based on 5 point Likert scale. In "Mental Health and Covid-19 Questionnaire", the respondents were categorized in the following ways: - Respondents who scored between 150-101 that is above 100 were considered severe that is these respondents higher scores indicate more mental health problems in covid-19. Respondents who scored between 100-51 that is above 50 were considered moderate that is these respondents scores indicate moderate level of mental health problems in covid -19. Respondents who scored between 50-30 were considered mild that is these respondents low scores indicate less mental health problems in covid-19.

### STATISTICAL ANALYSIS

The data were entered in a computer-based spreadsheet. It was checked for errors and cleaned before being analyzed. SPSS software was used for statistical computations. Descriptive statistics in the forms of means, median and standard deviations (SDs) have been presented. The continuous variables such as age, gender and occupation were used. Pearson correlation coefficient for calculating correlations was used in order to assess the statistical significance of any differences & relationships between parameters of the research in question.

The two variables internet usage and mental health were correlated.

### 4. RESULT

Scores were calculated for 100 participants. Out of 100 participants 76.4 % participants were females and 23.6% participants were males. Among these, 78 responses that is 63.4 % were from students. online test was conducted using google forms on people between age group of 16-22. Two questionnaire were used for the same purpose that is "Mental health and covid-19" and other is "Internet usage in covid-19"QUESTIONNARIE.

Table 1.0 Scores in Mental Health during COVID 19

The Scatter chart 1.1 above depicts Mental Health in covid-19. The chart is based on total score of respondents on the test that is "MENTAL HEALTH AND COVID-19 Questionnaire. The result shows that there are 18 respondents who scored above 100 which means that these respondents are facing severe effect on mental health in covid-19. There are 78 respondents that scored between 51-100 which depicts moderate level of effect on mental health in covid-19. There are 4 respondents who scored between 30-50 that depicts mild effect on mental health in covid-19.

Thus, the result depicts that on average most respondents between age group of 16-22 seems to have MODERATE

EFFECT ON THEIR MENTAL HEALTH IN COVID-19.

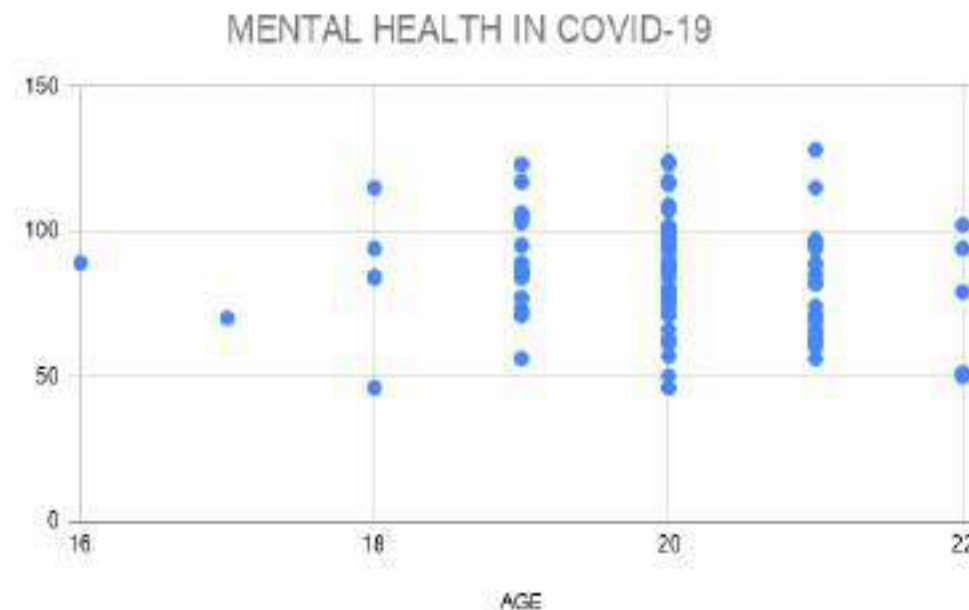
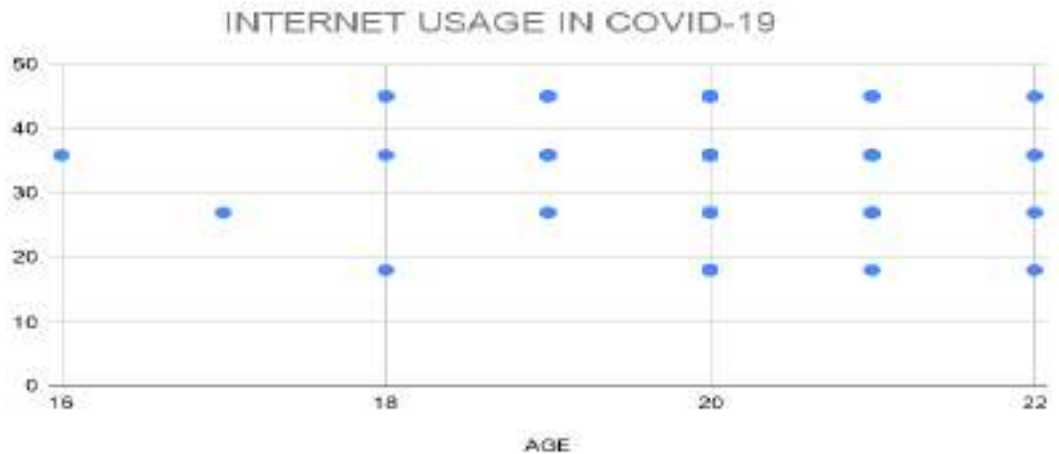


CHART 1.1 MENTAL HEALTH IN COVID-19

**TABLE 1.1 MENTAL HEALTH IN COVID-19**

MEAN	84.71
MEDIAN	85.5
STANDARD DEVIATION	18.88

Table 2.0 Scores in Internet Usage during COVID 19

**CHART 2.1 INTERNET USAGE IN COVID-19**

The SCATTER CHART 2 above depicts Internet usage in covid-19. The chart is based on total score of respondents on the test that is "INTERNET USAGE IN COVID-19 Questionnaires. The result shows that there are 74 respondents who scored above 30 which means that these respondents are high on internet usage in covid-19. There are 9 respondents that scored above 20

and below 30 which depicts that these respondents are medium on internet usage which is neither high nor low, in covid-19. There are 17 respondents who scored above 10 and below 20 that depicts low internet usage in covid-19. Thus, the result depicts that, on average most respondents between age group of 16-22 seems to have HIGH INTERNET USAGE IN COVID-19.

**TABLE 2.1 INTERNET USAGE IN COVID-19**

MEAN	35.27
MEDIAN	36
STANDARD DEVIATION	7.77

**COORELATION ANALYSIS**

		Internet usage in covid-19	Mental Health in covid-19
Internet usage in covid-19	Pearson Correlation	1	.851**
	Sig. (2-tailed)		.000
	N	100	100
Mental Health in covid-19	Pearson Correlation	.851**	1
	Sig. (2-tailed)	.000	
	N	100	100

\*\* . Correlation is significant at the 0.01 level (2-tailed).



The correlation analysis was conducted using SPSS software. The correlation table shown above depicts there is a positive correlation between Internet usage in covid-19 and Mental health in covid-19. This means that when Internet usage increases then, Mental health issues also increases. The correlation is significant at the 0.001 level (2 tailed).

## 5. DISCUSSION

This study confirmed our first hypothesis that is internet usage has an effect on mental health. Scores were calculated for 100 participants. Out of 100 participants 76.4 % participants were females and 23.6% participants were males. Among these, 78 responses that is 63.4 % were from students. online test was conducted using google forms on people between age group of 16-22. Two questionnaire were used for the same purpose that is "Mental health and covid-19" and other is "Internet usage in covid-19" QUESTIONNAIRE. In the study it was found that on average adolescents have high internet usage in covid-19 and moderate level of mental health issues were found among these adolescents. The mean and standard deviation for internet usage and mental health in covid-19 among respondents was found to be 84.71 and 18.88 and 35.27 and 7.77 respectively. The study also confirmed the second hypothesis that using the internet daily and increased screen time has a great impact on mental health psychologically, socially as well as emotionally. Internet use frequency is thus associated with depression, stress, anxiety, low self-esteem and low life satisfaction. Thus the association that Study moderates between internet usage and mental health in covid-19 was confirmed. This association was stronger for those who are students between age group of 16-22. In the study, it was found that there is a positive correlation between internet usage and mental health. correlation is significant at the 0.001 level (2 tailed). This means as internet usage increases, mental health problem also increases. Thus, our null hypothesis is rejected that there is no association between internet usage and mental health in covid-19 and internet usage has no impact on adolescent's mental health during covid-19.

## 6. CONCLUSION

The findings of the study showed that there is an association between internet usage and mental health among adolescents in covid -19. Most of the adolescents with high internet usage had Mental Health problem. High internet usage on surfing internet, using social media, gaming etc. was thus, correlated with depression, anxiety, low self-esteem and low life satisfaction. The researcher concluded that the Mental

Health problems due to internet usage can be prevented as well as coping can be enhanced, if provided awareness and identified at earlier stage.

## REFERENCES

1. Ahsoru D.K., Lin C.-Y., Imani V., Saffari M., Griffiths M.D. & Pakpour A.H. (2020). The fear of covid-19 scale: development and initial validation. *Int.J. Mental Health Addiction*.
2. Brooks S.K., Webster R.K., Smith L.E., Woodland L., Wessely S., Greenberg N. (2020). The psychological impact of quarantine and how to reduce it: rapid review of the evidence. *The Lancet*.
3. Schimmenti A., Billieux J., Starcevic V. (2020). The four horsemen of fear: an integrated model of understanding fear experiences during the COVID-19 pandemic. *Clin Neuropsychiatry*.
4. Centers for Disease Control and Prevention. (2020). *Coronavirus disease 2019 (COVID-19): Stress and coping*.
5. Mamun M.A., Griffiths M.D. (2020). First COVID-19 suicide case in Bangladesh due to fear of COVID-19 and xenophobia: possible suicide prevention strategies. *Asian J Psychiatry*.
6. Kaufman K.R., Petkova E., Bhui K.S., Schulze T.G. (2020). A global needs assessment in times of a global crisis: world psychiatry response to the COVID-19 pandemic. *BJPsych Open*
7. World Health Organization. (2020a). #HealthyAtHome.
8. Blasi M.D., Giardina A., Giordano C., Coco G.L., Tosto C., Billieux J. (2019). Problematic video game use as an emotional coping strategy: evidence from a sample of MMORPG gamers. *J Behav Addict*.
9. Jacobs D.F. (1986). A general theory of addictions: a new theoretical model. *Journal of Gambling Behavior*.
10. Khantzian E.J. (2013). Addiction as a self-regulation disorder and the role of self-medication. *Addiction*.
11. Király O., Urbán R., Griffiths M.D., Ágoston C., Nagygyörgy K., Kökönyei G. (2015). Psychiatric symptoms and problematic online gaming: the mediating effect of gaming motivation. *J Med Internet*
12. Billieux J., Schimmenti A., Khazaal Y., Maurage P., Heeren A. (2015). Are we overpathologizing everyday life? A tenable blueprint for behavioral addiction research. *J Behav Addict*.
13. King D.L., Delfabbro P.H., Billieux J., Potenza M.N. (2020). Problematic online gaming and the COVID-19 pandemic. *J Behav Addict*.
14. Ko C.H., Yen J.-Y. (2020). Impact of COVID-19 on gaming disorder: monitoring and prevention. *Journal of Behavioral Addictions*.
15. Mestre-Bach G., Blycker G., Potenza M. (2020). Pornography use in the setting of the COVID-19 pandemic. *J Behav Addict*.





16. World Health Organization. (2020b). *Mental health and psychosocial considerations during the COVID-19 outbreak*.
17. Conrad R., Rayala H., Diamond R., Busch B., Kramer N. (2020). Expanding telemental health in response to the COVID-19 pandemic. *Psychiatric Times*.
18. Fineberg N.A., Demetrovics Z., Stein D.J., Ioannidis K., Potenza M.N., Grünblatt E. (2018). *Manifesto for a European research network into problematic usage of the internet*. *Eur Neuropsychopharmacol*.
19. Peeters M., Koning I., Lemmens J., Eijnden, R. v. d. (2019). Normative, passionate, or problematic? Identification of adolescent gamer subtypes over time. *J Behav Addict*.
20. Vismara M., Caricasole V., Starcevic V., Cinosi E., Dell'Osso B., Martinotti G. (2020). Is cyberchondria a new transdiagnostic digital compulsive syndrome? A systematic review of the evidence. *Compr Psychiatry*.
21. Rumpf H.-J., Achab S., Billieux J., Bowden-Jones H., Carragher N., Demetrovics Z., Poznyak. (2018). Including gaming disorder in the ICD-11: The need to do so from a clinical and public health perspective: commentary on: a weak scientific basis for gaming disorder: let us err on the side of caution (van Rooij et al., 2018). *J Behav Addict*.
22. World Health Organization. (2019). *ICD-11 for Mortality and Morbidity Statistics*.
23. Fisher, Titus. (2018, September 18). *The Effects of technology on mental health*. *Healthy living blog*.
24. San Diego State University. (2018, January 22). *Screen-addicted teens are unhappy: A new study finds that more screen time is coincides with less happiness in youths*. *ScienceDaily*.
25. Singh, Shweta & Dixit, Ayushi & Joshi, Gunjan. (2020). "Is compulsive social media use amid COVID-19 pandemic addictive behavior or coping mechanism." *Asian Journal of Psychiatry*.
26. Guessoum SB, Lachal J, Radjack R, et al. (2020). Adolescent psychiatric disorders during the COVID-19 pandemic and lockdown. *Psychiatry Research*.
27. Hilarie Cash, Cosette D Rae, Ann H Steel, Alexander Winkler. (2012). *Internet addiction: A brief summary of Research and practice*. *Curr Psychiatry Rev*.
28. Lawrence Robinson and Melinda Smith, M.A. (September 2020). *Social media and mental health. Help guide*.
29. Cummins, R.A., & Nistico, H. (2002). Maintaining life satisfaction: The role of positive cognitive bias. *Journal of Happiness Studies*.
30. Shin, D.C., & Johnson, D.M. (1978). Avowed happiness as an overall assessment of the quality of life. *Social Indicators Research*.
31. Diener, E. (1984). Subjective well-being. *Psychological Bulletin*.
32. Andrews, F.M., & Withey, S.B. (1976). *Social indicators of well-being: America's perception of life quality*. New York, NY: Plenum.
33. Bozoglan, B., Demirer, V., & Sahin, I. (2013). Loneliness, self-esteem, and life satisfaction as predictors of Internet addiction: a cross-sectional study among Turkish university students. *Scandinavian Journal of Psychology*.
34. Affonso, B. (1999). *Is the internet affecting the social skills of our children?*
35. Shapira, N.A., Goldsmith, T.D., Keck, P.E., Jr., Khosla, U. M., & McElroy, S.L. (2000). Psychiatric features of individuals with problematic internet use. *Journal of Affective Disorder*.
36. Weiser, E.B. (2001). *The functions of Internet use and their social and psychological consequences*. *Cyberpsychology and Behavior*.
37. Gross, E.F., Juvonen, J., & Gable, S.L. (2002) *Internet use and wellbeing in adolescence*. *The Journal of Social Issues*.
38. Sanders, C.E., Field, T.M., Diego, M. & Kaplan, M. (2000). *The relationship of Internet to depression and social isolation among adolescents*. *Adolescence*.
39. Wastlund, E., Norlander, T., & Archer, T. (2001). *Internet blues revisited*.
40. *Replication and extension of an Internet paradox study*. *Cyberpsychology and Behavior*.
41. Gangadhar, B.N. (2020, April). *Mental health in times of covid-19 pandemic: Guidance for General Medical and Specialised Mental Health Care Settings*. Department of Psychiatry, NIMHANS.



## INDUSTRY AND CORPORATE SOCIAL RESPONSIBILITY IN INDIA

**Dr. K.Somasekhar**

*Associate Professor, Dept. of Rural Development, Acharya Nagarjuna University, Guntur – 522510, A.P.*

Article DOI: <https://doi.org/10.36713/epra7493>

DOI No: 10.36713/epra7493

### ABSTRACT

*Corporate Social Responsibility is a concept where by industries to take care of the Society interests in every aspect. The objective of the CSR is to improve the standards of living while preserving the profitability of the corporation for its stake holders both within the and outside the industry. In the recent years the concept of corporate social responsibility is spreading very rapidly in India at all the sectors. Corporate social responsibility is to contribute towards the society while working with in ethics. In developing countries like India. Industries plays a very important role in upgrading the economy of the country not only by producing products but also by imposing a new practice called social responsibility (CSR). In the global economy the link between industries and government has been growing. Business is an inseparable and embedded part of the society. Corporate social responsibility is an evolving a number of internal and external policies and practices right from the place where they work to the community, the environment and beyond. In the present scenario, there is need to take new initiatives and adopt new policies taking into consideration of the industry history towards sustained environmental, Social and Economic growth.*

**KEY WORDS:** *CSR practices, Stake holders, Ethics, Environment, Economic growth.*

### INTRODUCTION

In a context of change and globalization, businesses are increasingly asked to pursue their mission paying attention to the needs of the stakeholders whose well-being depends on the way enterprises manage their core activities. Organizations are being called upon to take responsibility for the ways their operations impact societies and the natural environment. Today, business leaders and the civil society play a greater role in the transformation of value systems and institutional arrangements (Jonung, M & Malhotra M. 2007). In an increasingly global economy, pillars of business and government are now tied together as the symbol of a growing link between the public and the private sector. There is evidence of a rising perception that globalization creates poverty and inequality. Business is an inseparable and embedded part of the society. In addition to its economic role in society, business also has several other roles and responsibilities towards society, viz. responsible conduct of business activities while pursuing economic gains; the social and environmental responsibilities of

the business towards its stakeholders; and business's contributions that would benefit the society at large (Margolis and Walsh, 2001). The business environment has undergone vast changes in the recent years in terms of both the nature of competition and the wave of globalization that has been sweeping across markets. Companies are beginning to realize the fact that in order to gain strategic initiative and to ensure continued existence, business practices may have to be moulded from the normal practice of solely focusing on profits to factor in public goodwill and responsible business etiquettes (Reynard and Forstater, 2002). India's recent economic progress has not only increased pressure on the environment, but also generated social tension by increasing the gap between India's middle class and the poor. Consequently, it has become even more important for corporations to consider their broader impact on society. The traditional ethos of maximizing shareholder value without regard too their stakeholders is an outdated notion in today's global environment. Corporate social responsibility (CSR) has a powerful potential to make positive contributions to addressing



the needs of disadvantaged communities in developing countries. CSR issues can become complex when they acquire an international dimension.

### **APPROACHES TO CSR**

As companies they face the challenges of a changing environment in the context of globalization and in particular the Internal Market, they are increasingly aware that corporate social responsibility can be of direct economic value. CSR should be treated as an investment, not a cost, much like quality management. They can thereby have an inclusive financial, commercial and social approach, leading to a long-term strategy minimizing risks linked to uncertainty. Companies should pursue social responsibility for which there are various approaches. They are - philanthropy approach, a holistic approach (green paper, 2001), triple bottom line (TBL) approach, and cluster approach and triple-p approach. A company that does poorly on one line, namely profits, but wonderfully on the environment or social component of TBL, is not going to last long in a competitive world. So concentration on defining exactly what is meant by a corporation's responsibility to its stakeholders, who they are and how to measure progress through a limited number of precise key indicators (Hopkins, Michael – 2004).

### **THE INDIAN SCENARIO**

CSR is a globally applicable concept but its interpretation will vary from country to country, industry to industry and company to company because of differing local situations and differing demands of stakeholders in different locations and industries. With the retreat of the state in economic activity in India, the imperative for business to take up wider social responsibilities is growing. The situation is complex and India is facing a compounded set of corporate responsibility challenges. At all levels, there is a felt need for companies to graduate to strategic interventions in CSR, which at present in many cases remain ad hoc. There are many companies that may spend for long-term development. A sense of strategic direction is a vital component in an effective approach to corporate responsibility. Yet, for all these signs of progress, CSR in India has yet to realize its full potential. Individual and collaborative initiatives continue to be dominated by self-assertion rather than accountability. There is certainly no lack of CSR programmes and projects in India: however, clear metrics for evaluating their actual impact in improving social conditions is missing. Many Indian business houses, private sector and public sector companies have

undertaken major initiatives till date and have adopted several modes of practice related to CSR in India.

Several innovative measures have also been adopted by companies towards the institutionalization of CSR that includes CSR initiatives by Lupin, Cipla, Ranbaxy, NIIT, TCS, BPCL, and Ion Exchange. For long-established industrial dynasties, such as the Birla's and the Tata's, concepts of nation- building and trusteeship have been alive in their operations long before CSR become a popular cause. Alongside these are the leading Indian companies with strong international shareholdings, such as Hero Honda, HLL, ITC, and Maruti Udyog, where local dynamics fuse with the business standards of the parent or partner. Another tradition emerges from the public sector enterprises, such as BHEL, HDFC, NTPC, and ONGC, where social obligations remain an integral part of their business despite the march of privatization. And then there is the new generation of enterprises that has surged on the back of knowledge based globalization, such as Dr Reddy's, Infosys, Ranbaxy, and Wipro, where less emphasis is on minimizing negative impacts and more on maximizing the positive spill-over effects of corporate development.

### **CSR PRACTICES IN INDIAN COMPANIES**

Bharat Petroleum and Maruthi udyog have been ranked as the best companies in the country. The next comes in the list are Tata Motors and Hero Honda. Canara Bank, Indal, Gujarat Ambuja and Wipro are involved in community development work. BHEL is actively involved in the welfare of the surrounding communities is helping the organization to earn goodwill of the local people. BHEL is also providing drinking water facilities, construction of roads, provision of health and educational facilities. ONGC has committed resources by adopting a few villages to implement President Dr. Abdul Kalam's idea of PURA (Provision of Urban Amenities in Rural Areas). Similarly in the private sectors like Infosys, Wipro and Reliance are believed to be most socially responsible corporations. In developing countries like India, CSR stands to be of vital importance for a mutual and symbiotic growth. Coca- Cola in India and Unilever in Pakistan are two examples. The following issues and companies are reviewed for their CSR practices.

### **EMPLOYEE ISSUES**

**Tata Group** - has more than 2, 45,000 employees. Tata were the pioneers in employee benefits that were later mandated through legislation in India and elsewhere in the world. The eight-hour working day, free medical aid, welfare departments,



grievance cells, leave with pay, provident fund, accident compensation, training institutes, maternity benefits, bonus and gratuity were introduced by the group before any legal rules were framed on them. Tata has created cities and towns – Jamshedpur, Mithapur, Babrala and Mathigiri – around industrial facilities.

**HLL** - approximately 9% of the company's resources for community involvement come in the form of employee time. Their time is ranged from their involvement in Ashadaan to the disaster affected Yashodadham village near Bhuj. HLL management trainees spend approximately four weeks on Project Shakti in rural areas with NGOs or Self Help Groups.

**Infosys** - employees are encouraged to report workplace hazards and incidents to the concerned officials and contribute to implementing solutions. Infosys implemented health clubs and health programmes, such as health week, nutrition programmes and ergonomics training.

## RESPONSIBLE FOR THE COMMUNITY

**Bajaj Auto's** philanthropic activities among the rural poor are carried out by a Trust, the Jankidevi Bajaj Gram Vikas Sanstha (JBGVS) established in 1987 by Ramkrishna Bajaj in memory of his mother, Jankidevi Bajaj. This Trust acts as a catalyst to development at the grass root level in 32 villages around its plants in Pune and Aurangabad. These projects have a positive impact on the quality of rural living standards.

**Dabur** has a vision of being a company dedicated to the health and well being of every household, drawing inspiration from its founder Dr. S. K. Burman. In 1993, Dabur India Ltd established Sustainable Development Society (SUNDESH), a registered voluntary organisation, integrating various aspects such as health, literacy, employment, and empowerment. The Company organizes camps, which include general OPDs, antenatal check-up, vaccination for children aged 0-5 years, family welfare, health awareness through meetings, eye screening and eye operation camps.

**Infosys Foundation**, the philanthropic arm of Infosys Technologies Ltd, came into existence on 4 December 1996. Its main objective was to fulfill the social responsibility of the company by supporting and encouraging the underprivileged sections of society. The Foundation has been working on initiatives such as: training destitute woman in tailoring and donation of sewing machines and material to them to improve their livelihood; counseling centers to rehabilitate marginalized devadasis in North Karnataka; relief work conducted after natural disasters; donation of aid equipment to the physically challenged in rural areas of

Karnataka; and construction of orphanages in rural areas.

## THE ENVIRONMENT

**Godrej** has been a key player in aiding education, environment and the health verticals besides looking after its own employees. The Soonabai Pirojsha Godrej Foundation has been maintaining the western bank of the Thane Creek, the single largest mangrove belt in Mumbai. The Sohrabji Godrej Green Business Centre launched the Green Business Initiative in December 2005, which was aimed at facilitating the development of corporate greenhouse gas inventories and subsequent investments in greenhouse gas mitigation projects.

**ITC**- focuses on the use of renewable energy such as biomass and solar energy. A number of units have installed solar thermal systems mainly for use in canteens and kitchens. It claims it endeavors to be a carbon positive corporation. Its efforts in the field of energy conservation, use of carbon neutral fuels and large scale tree plantations through social and farm forestry have resulted in sequestering 85.6% of the Carbon Dioxide (CO<sub>2</sub>) emitted by its operations.

**Indian Oil Corporation:** has included CSR in its vision and mission statement and has built its corporate strategies around it. Environmental initiatives include: development of cleaner fuels such as diesel with low sulphur content and biodegradable lube formulations; pollution control programme, in which all refineries are provided with facilities to control pollution from different sources; and ecological parks, which are scientifically designed green belts that have been developed at Gujarat Panipat refineries, to serve as a pollution sink and to enhance the aesthetic look of the refinery area.

## CONCLUSION

Business houses all over the world are increasing in realizing their stake in the society and engaging in various social and environmental activities. Corporate social responsibility is an evolving concept that incorporates a wide range of internal and external policies and practices extending from the workplace, into the community, the environment and beyond. Nevertheless CSR has certain limitations which restrict its activities. The need of the hour is to formulate effective strategic policies and adopt various instruments according to the company history, its content, peculiarity in relationship with its different stakeholders so that CSR can be best implemented towards its goals – sustained environmental, social and economic growth. Corporate together can make the





world as a better place to live. A CSR strategy provides businesses with the opportunity to show their human face. Business success and continually satisfying the customer and other stakeholders are closely tied to adoption and implementation of high standards of business and marketing conduct. Deceiving customers may help a firm's profits in the short-run, but is not the way to build a successful business. CSR represents good business practice for every function and should not be confined to a few departments in isolation from one another.

## REFERENCES

1. Carroll, A. (1998) – *The Four Faces of Corporate Citizenship*. *Business and Society Review*, September, 100 (1):1-7.
2. Chakrabarty, Sumit (2008) – 'CSR in the Era of Globalization - Impact on Developing Countries' (India), NSIBM, Jamshedpur.
3. Ebner, Daniela & Rupert J. Baumgartner (2008) – *The relationship between Sustainable Development and Corporate Social Responsibility*, *Corporate Responsibility Research Conference, CRRC 2008: 7-9 September, Queen's University Belfast*, 1-17.
4. GOI (2010) – *Guidelines on Corporate Social Responsibility for Central Public Sector Enterprises*, Department of Public Enterprises, Ministry of Heavy Industries & Public Enterprises, New Delhi, 15(3)/2007 -OPE (GM), March.
5. Green Paper (2001) – *Promoting a European Framework for Corporate Social Responsibility*, Commission of the European Communities, Brussels, COM-366:1-32.
6. GTZ's Contribution (2010) – *Corporate Social Responsibility and Development Cooperation*, Centre for Cooperation with the Private Sector, Germany.
7. Hediger, Werner (2008) – *Framing corporate social responsibility and contribution to sustainable development*, *CRRC 2008: 7-9 September, Queen's University Belfast*.
8. Hopkins, Michael (2004) – *Corporate social responsibility: an issues paper*, Working Paper No. 27, Policy Integration Department, World Commission on the Social Dimension of Globalization, International Labour Office, Geneva.
9. Kadrolkar, Vilas M. (2010) - *Multinational Corporations and Corporate Social Responsibilities, in an edited book by Dr. Francis Cherunilam- 'International Business: Socio-Economic, Ecological, Political and Technological Trends and Dimensions' (Compendium of Conference Papers) Himalaya Publishing House, New Delhi: 589 – 605.*
10. Kadrolkar, Vilas M. (2008) – *'Globalization and Corporate Social Responsibilities'* *NITTE Management Review, bi annual journal of Justice K.S. Hegde, Institute of Management, Nitte, December, 2 (2) : 62 - 71.*
11. McWilliams, A., & Siegel, D. (2001) – *'Corporate Social Responsibility: A Theory of the Firm Perspective'*. *Academy of Management Review*, 26: 117-127.
12. Prahalad, C. K. (2004) – *The Fortune at the Bottom of the Pyramid*, Philadelphia: University of Pennsylvania, Wharton School Publishing.
13. Prieto-Carrón, M., Lund-Thomsen P, Chan A, Ana Muro & Chandra Bhushan (2006) – *Critical Perspectives On CSR and Development: What We Know, What We Don't Know, and What We Need To Know*, *International Affairs*, 82 (5): 977–987.





# A STUDY ON FLUCTUATIONS OF INDIAN CURRENCY WITH RESPECT TO SELECTED FOREIGN CURRENCIES

United States dollar (\$), Great Britain Pound (sterling) (£), European Union Euro (€)

**Amtul Wahab**

*Research Scholar from OU, Lecturer in Commerce, Indira Priyadarshini Govt. Degree,  
College for Women, Nampally, Hyderabad*

## INTRODUCTION

The currency market has long served an important function in global business by providing companies a way to exchange funds in one currency for funds in another. The evolution of the Internet in the late 20th and early 21st century propelled growth in online Forex brokers. This gave regular investors an easy and effective way to speculate in currencies for profit, based on the ongoing changes in prices. A currency has value, or worth, in relation to other currencies, and those values change constantly. Currency fluctuations are a natural outcome of the floating exchange rates. The exchange rate of one currency versus the other is influenced by numerous fundamental and technical factors.

## NEED OF THE STUDY

To know the in brief about different currencies (selected) traded in foreign exchange.  
To evaluate the changes in value of selected foreign currency.  
To find whether investment in the currency is profitable or not.

## OBJECTIVE OF THE STUDY

To study the foreign exchange rates of selected foreign currencies  
To compare the value of Indian rupee with other selected foreign currency  
To evaluate the changes in the value of the currency

## SCOPE OF THE STUDY

The scope of the study is limited to foreign exchange rates of selected foreign currencies. The currencies involved in the study are as follows:

- 1 United States dollar (\$)
- 2 Great Britain pound (sterling) (£)
- 3 European Union euro (€)

## PERIOD OF THE STUDY

The study is conducted from 1 January 2017 to 31 December 2017

## Limitations of the study

It will be limited to the selected currencies  
The study is limited to period of time

## INTRODUCTION TO FOREIGN EXCHANGE & ITS ADMINISTRATIVE FRAME WORK

**Foreign exchange:** Foreign exchange is the mechanism by which the currency of one country gets converted into the currency of another country. The conversion is done by banks who deal in foreign exchange. These banks maintain stocks of foreign currencies in the form of balances with banks abroad. For instance, Indian Bank may maintain an account with Bank of America, New York, in which dollars are held.



**Some of the important factors which affect exchange rates are**

**Balance of payment:** It represents the demand for and supply of foreign exchange which ultimately determine the value of the currency. Exporters from the country demand for the currency of the country in the forex market. The exporters would offer to the market the foreign currencies have acquired and demand in exchange the local currency. Conversely, imports into the country will increase the supply of currency of the country in the forex market. When the BOP of a country is continuously at deficit, it implies that demand for the currency of the country is lesser than the supply.

**Inflation:** Inflation in the country would increase the domestic prices of the commodities. With increase in prices exports may dwindle because the price may not be competitive.

**Interest rates:** The interest rate has a great influence on the short-term movement of capital. When the interest rate at a center rises, it attracts short term funds from other centers.

**Money supply:** An increase in money supply in the country will affect the exchange rates through causing inflation in the country. It can also affect the exchange rate directly.

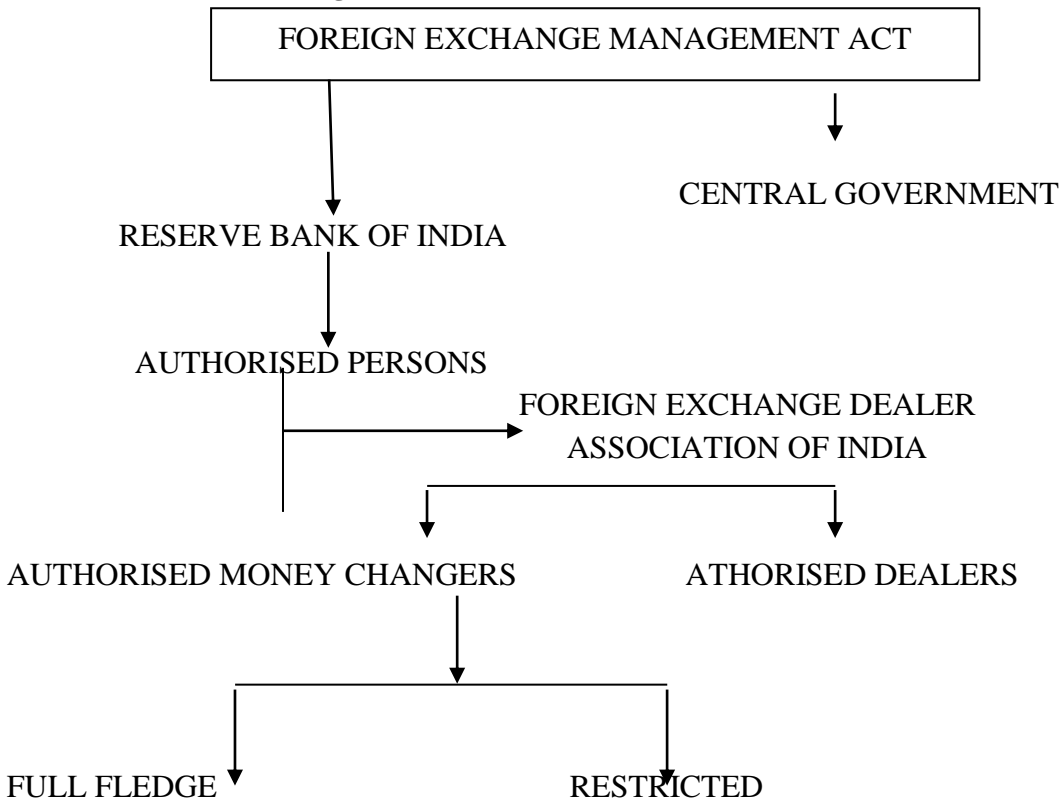
**National income:** An increase in national income reflects increase in the income of the residents of the country. The increase in the income increases the demand for goods in the country.

**Resource discoveries:** When the country is able to discover key resources, its currency gains in value.

**Capital Movements:** There are many factors that influence movement of capital from one country to another. Short term movement of capital may be influenced by the offer of higher interest in a country

**ADMINISTRATION FRAME WORK FOR FOREIGN EXCHANGE IN INDIA**

**Fig: ADMINISTRATION OF FOREIGN EXCHANGE IN INDIA**





**FOREIGN EXCHANGE DEALER’S ASSOCIATION OF INDIA (FEDAI):** FEDAI was established in 1958 as an association of all authorized dealers in India. The principal functions of FEDAI are: To frame rules for the conduct of foreign exchange business in India. These rules cover various aspects like hours of business, charges for foreign exchange transactions, quotation of rates to customer, inter-bank dealings, etc. All authorized dealers have given undertaking to the Reserve Bank to abide these rules. To co-ordinate with Reserve Bank of India in Proper administration of exchange control. To control information likely to be of interest to its members.

**US Dollar :** The United States dollar (sign: \$; code: USD, U.S. dollar, or American dollar) is the official currency of the United States and its insular territories per the United States Constitution since 1792. For most practical purposes, it is divided into 100 smaller cent (¢) units, but officially it can be divided into 1000 mills (m).

**Exchange rate of US Dollar ( 1-1-17 to 31-12-17) with reference to Indian rupee**

S.NO	Date	US Dollar	Date	US Dollar	Date	US Dollar
1	1/2/2017	68.0225	3/1/2017	66.8482	5/2/2017	64.2072
2	1/3/2017	68.0864	3/2/2017	66.7433	5/3/2017	64.1439
3	1/4/2017	68.1791	3/3/2017	66.8354	5/4/2017	64.2115
4	1/5/2017	67.7884	3/6/2017	66.7559	5/5/2017	64.3079
5	1/6/2017	67.9522	3/7/2017	66.6347	5/8/2017	64.2154
6	1/9/2017	68.1863	3/8/2017	66.6362	5/9/2017	64.5065
7	1/10/2017	68.0641	3/9/2017	66.7707	5/11/2017	64.438
8	1/11/2017	68.2276	3/10/2017	66.688	5/12/2017	64.3043
9	1/12/2017	68.0858	3/14/2017	66.6618	5/15/2017	64.1188
10	1/13/2017	68.231	3/15/2017	65.5146	5/16/2017	64.0758
11	1/16/2017	68.1558	3/16/2017	65.3836	5/17/2017	64.0214
12	1/17/2017	68.0509	3/17/2017	65.5411	5/18/2017	64.3441
13	1/18/2017	67.9364	3/20/2017	65.3827	5/19/2017	64.9906
14	1/19/2017	68.1766	3/21/2017	65.3117	5/22/2017	64.5632
15	1/20/2017	68.0883	3/22/2017	65.4881	5/23/2017	64.7751
16	1/23/2017	68.0843	3/23/2017	66.5422	5/24/2017	64.8586
17	1/24/2017	68.157	3/24/2017	65.4581	5/25/2017	64.5088
18	1/25/2017	68.1556	3/27/2017	65.0892	5/26/2017	64.5945
19	1/27/2017	68.2043	3/29/2017	64.9552	5/29/2017	64.5565
20	1/30/2017	68.0426	3/30/2017	64.9325	5/30/2017	64.6336
21	1/31/2017	67.8125	3/31/2017	64.8386	5/31/2017	64.5459
22	2/1/2017	67.6458	4/3/2017	64.9103	6/1/2017	64.4704
23	2/2/2017	67.448	4/5/2017	65.0438	6/2/2017	64.4208
24	2/3/2017	67.3825	4/6/2017	64.9791	6/5/2017	64.3485
25	2/6/2017	67.1958	4/7/2017	64.3928	6/6/2017	64.3516
26	2/7/2017	67.3692	4/10/2017	64.4418	6/7/2017	64.4538
27	2/8/2017	67.3058	4/11/2017	64.5438	6/8/2017	64.3554
28	2/9/2017	67.0123	4/12/2017	66.4692	6/9/2017	64.2584
29	2/10/2017	66.9367	4/13/2017	64.3165	6/12/2017	64.3407
30	2/13/2017	66.9663	4/17/2017	64.4053	6/13/2017	64.4453
31	2/14/2017	66.9439	4/18/2017	64.5657	6/14/2017	64.3141
32	2/15/2017	66.9193	4/19/2017	64.5443	6/15/2017	64.2801
33	2/16/2017	66.9468	4/20/2017	64.6364	6/16/2017	64.5883



34	2/17/2017	67.0467	4/21/2017	64.5701	6/19/2017	64.3788
35	2/20/2017	66.9771	4/24/2017	64.4757	6/20/2017	64.4672
36	2/22/2017	66.9644	4/25/2017	64.2776	6/21/2017	64.6025
37	2/23/2017	66.8351	4/26/2017	64.0013	6/22/2017	64.495
38	2/27/2017	66.7249	4/27/2017	64.1141	6/23/2017	64.5365
39	2/28/2017	66.7375	4/28/2017	664.217	6/27/2017	64.4572

S.NO	Date	US Dollar	Date	US Dollar	Date	US Dollar
1	6/28/2017	64.5288	8/30/2017	63.9431	11/1/2017	64.5256
2	6/29/2017	64.4715	8/31/2017	64.0154	11/2/2017	64.593
3	6/30/2017	64.7379	9/1/2017	63.9804	11/3/2017	64.5764
4	7/3/2017	64.7525	9/4/2017	64.0468	11/6/2017	64.7267
5	7/4/2017	64.8168	9/5/2017	64.1164	11/7/2017	64.8064
6	7/5/2017	64.7209	9/6/2017	64.2146	11/8/2017	65.0592
7	7/6/2017	64.7779	9/7/2017	64.0276	11/9/2017	64.8967
8	7/7/2017	64.7342	9/8/2017	63.8664	11/10/2017	65.0147
9	7/10/2017	64.5405	9/11/2017	63.8859	11/13/2017	65.4272
10	7/11/2017	64.5025	9/12/2017	63.9474	11/14/2017	65.5171
11	7/12/2017	64.4969	9/13/2017	63.9818	11/15/2017	65.3689
12	7/13/2017	64.4384	9/14/2017	64.0692	11/16/2017	65.2969
13	7/14/2017	64.4539	9/15/2017	64.0774	11/17/2017	64.8462
14	7/17/2017	64.3666	9/18/2017	64.0371	11/20/2017	65.0565
15	7/18/2017	64.3301	9/19/2017	64.1769	11/21/2017	65.0386
16	7/19/2017	64.3211	9/20/2017	64.3637	11/22/2017	64.7453
17	7/20/2017	64.4273	9/21/2017	64.5256	11/23/2017	64.7949
18	7/21/2017	64.3185	9/22/2017	64.9596	11/24/2017	64.7328
19	7/24/2017	64.4494	9/25/2017	64.8357	11/27/2017	64.6948
20	7/25/2017	64.358	9/26/2017	65.3371	11/28/2017	64.4206
21	7/26/2017	64.4208	9/27/2017	65.6947	11/29/2017	64.4058
22	7/27/2017	64.1216	9/28/2017	65.7604	11/30/2017	64.4332
23	7/28/2017	64.1483	9/29/2017	65.3552	12/4/2017	64.3799
24	7/31/2017	64.0773	10/3/2017	65.5529	12/5/2017	64.3764
25	8/1/2017	64.0683	10/4/2017	65.2899	12/6/2017	64.4467
26	8/2/2017	64.069	10/5/2017	65.1758	12/7/2017	64.5388
27	8/3/2017	63.6314	10/6/2017	65.2276	12/8/2017	64.4649
28	8/4/2017	63.7091	10/9/2017	65.3074	12/11/2017	64.3616
29	8/7/2017	63.7375	10/10/2017	65.2652	12/12/2017	64.4834
30	8/8/2017	63.7382	10/11/2017	65.2691	12/13/2017	64.4525
31	8/9/2017	63.7491	10/12/2017	65.1003	12/14/2017	64.2798
32	8/10/2017	63.9437	10/13/2017	64.9301	12/15/2017	64.0958
33	8/11/2017	64.1693	10/16/2017	64.7603	12/18/2017	64.1065
34	8/14/2017	64.0253	10/17/2017	64.9226	12/19/2017	64.1205



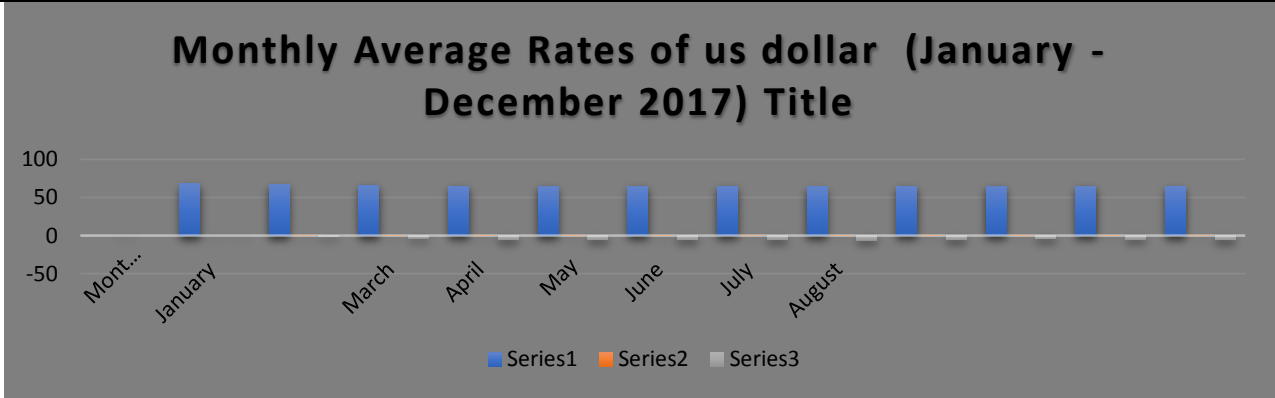
35	8/16/2017	64.2428	10/18/2017	65.0649	12/20/2017	64.0577
36	8/18/2017	64.1048	10/23/2017	65.0239	12/21/2017	64.0883
37	8/21/2017	64.0285	10/24/2017	64.9256	12/22/2017	64.0409
38	8/22/2017	64.1099	10/25/2017	65.1386	12/26/2017	64.0538
39	8/23/2017	64.1272	10/26/2017	64.7888	12/27/2017	64.1577
40	8/24/2017	64.0676	10/27/2017	65.0931	12/28/2017	64.1716
41	8/28/2017	63.8701	10/30/2017	64.9338	12/29/2017	63.9273
42	8/29/2017	64.0174	10/31/2017	64.7745		

Calculation of monthly average rates of US Dollar

Average monthly rate = sum of rates / no of days in a month

% change in US Dollar (monthly): = current month rate –base rate / base rate

Monthly Average Rates of us dollar (January -December 2017)		% change in us dollar	
January	68.08036667	0	0
February	67.07545	-0.014760741	-1.476074115
March	65.87665714	-0.032369237	-3.236923709
April	64.50708889	-0.052486171	-5.248617119
May	64.4248381	-0.053694314	-5.369431378
June	64.44299048	-0.053427682	-5.342768213
July	64.45588095	-0.05323834	-5.323834017
August	63.968385	-0.060398935	-6.039893542
September	64.44094762	-0.053457689	-5.345768873
October	65.08128421	-0.04405209	-4.40520903
November	64.86261364	-0.047264038	-4.726403789
December	64.24232105	-0.05637522	-5.637521958



**Interpretation**

The above table and bar diagram showing monthly average rates and % change in value of currency 2017. The value of January 2017 is considered as base rate which is 68.08036667. The currency value is decreasing every month. From January to February there is a decrease of 1.476%. The decreased change in March is 3.23% and approximately 5.5% in April, May, June, July & September. There is a highest decrease in August month i.e. 6.039%. There is a decrease of 4.4% and 4.72% in October and November respectively. It raised to 5.637% in December 2017.

**Great Britain Pound (sterling)**

The pound sterling (symbol: £; ISO code: GBP), commonly known as the pound and also referred to as Sterling, is the official currency of the United Kingdom, Jersey, Guernsey, the Isle of Man, South Georgia and the South Sandwich Islands, the British Antarctic Territory, and Tristan da Cunha.<sup>1</sup> It is subdivided into 100 pence.





**Exchange rate of Pound Sterling (1-1-17 to 31-12-17) with reference to Indian rupee**

S.NO	Date	GBP	Date	GBP	Date	GBP
1	2/1/2017	83.967	2/3/2017	81.9875	4/5/2017	82.5631
2	3/1/2017	83.7599	3/3/2017	81.9603	5/5/2017	83.1308
3	4/1/2017	83.533	6/3/2017	81.9762	8/5/2017	83.2553
4	5/1/2017	83.7051	7/3/2017	81.5342	9/5/2017	83.5295
5	6/1/2017	84.0976	8/3/2017	81.3162	11/5/2017	83.415
6	9/1/2017	83.1259	9/3/2017	81.1665	12/5/2017	82.869
7	10/1/2017	82.6979	10/3/2017	81.0526	15-05-2017	82.8351
8	11/1/2017	82.9579	14-03-2017	80.5014	16-05-2017	82.7795
9	12/1/2017	83.194	15-03-2017	80.0654	17-05-2017	82.7669
10	13-01-2017	82.9757	16-03-2017	80.2649	18-05-2017	83.3063
11	16-01-2017	81.9982	17-03-2017	80.9957	19-05-2017	84.1823
12	17-01-2017	82.4573	20-03-2017	81.0157	22-05-2017	83.9515
13	18-01-2017	83.8403	21-03-2017	80.6273	23-05-2017	84.0327
14	19-01-2017	83.6936	22-03-2017	81.6833	24-05-2017	84.0957
15	20-01-2017	84.1231	23-03-2017	81.8495	25-05-2017	83.7711
16	23-01-2017	84.6492	24-03-2017	81.6721	26-05-2017	83.1848
17	24-01-2017	85.1485	27-03-2017	81.6479	29-05-2017	82.8195
18	25-01-2017	85.3104	29-03-2017	80.4795	30-05-2017	82.7892
19	27-01-2017	85.4941	30-03-2017	80.7501	31-05-2017	82.6446
20	30-01-2017	85.5159	31-03-2017	80.8797	1/6/2017	82.8703
21	31-01-2017	84.847	3/4/2017	81.43	2/6/2017	82.9225
22	1/2/2017	84.9496	5/4/2017	80.8755	5/6/2017	82.7972
23	2/2/2017	85.4903	6/4/2017	81.1524	6/6/2017	83.1616
24	3/2/2017	84.3225	7/4/2017	80.2592	7/6/2017	83.2485
25	6/2/2017	83.9208	10/4/2017	79.8563	8/6/2017	83.4303
26	7/2/2017	83.9488	11/4/2017	80.1376	9/6/2017	81.7495
27	8/2/2017	84.1659	12/4/2017	80.8132	12/6/2017	82.0859
28	9/2/2017	83.819	13-04-2017	80.8265	13-06-2017	81.7424
29	10/2/2017	83.7713	17-04-2017	80.7192	14-06-2017	82.1098
30	13-02-2017	83.7614	18-04-2017	81.1785	15-06-2017	81.9121
31	14-02-2017	83.9811	19-04-2017	82.7458	16-06-2017	82.5116
32	15-02-2017	83.4149	20-04-2017	82.8057	19-06-2017	82.2053
33	16-02-2017	83.4358	21-04-2017	82.7014	20-06-2017	82.1506
34	17-02-2017	83.7614	24-04-2017	82.458	21-06-2017	81.5348
35	20-02-2017	83.1923	25-04-2017	82.2689	22-06-2017	81.799
36	22-02-2017	83.6921	26-04-2017	82.1265	23-06-2017	81.9743
37	23-02-2017	83.1228	27-04-2017	82.5854	27-06-2017	82.0798
38	27-02-2017	82.8923	28-04-2017	82.8271	28-06-2017	82.6614
39	28-02-2017	83.0548	2/5/2017	82.6925	29-06-2017	83.5615
40	1/3/2017	82.718	3/5/2017	82.7969	30-06-2017	84.2564
S.No	Date	GBP	Date	GBP	Date	GBP
1	3/7/2017	84.1718	31-08-2017	82.6951	31-10-2017	85.5995
2	4/7/2017	83.9118	1/9/2017	82.6627	1/11/2017	85.6706



3	5/7/2017	83.6065	4/9/2017	82.9662	2/11/2017	85.786
4	6/7/2017	83.8226	5/9/2017	82.8192	3/11/2017	84.4272
5	7/7/2017	83.8826	6/9/2017	83.6395	6/11/2017	84.6366
6	10/7/2017	83.2766	7/9/2017	83.4664	7/11/2017	85.3371
7	11/7/2017	83.0857	8/9/2017	83.8757	8/11/2017	85.5724
8	12/7/2017	82.6915	11/9/2017	84.2591	9/11/2017	85.2548
9	13-07-2017	83.248	12/9/2017	84.3594	10/11/2017	85.5463
10	14-07-2017	83.5451	13-09-2017	85.1534	13-11-2017	85.8209
11	17-07-2017	84.2173	14-09-2017	84.6867	14-11-2017	85.9388
12	18-07-2017	84.2917	15-09-2017	86.12	15-11-2017	85.9143
13	19-07-2017	83.8554	18-09-2017	87.0841	16-11-2017	86.0483
14	20-07-2017	83.9166	19-09-2017	86.8121	17-11-2017	85.785
15	21-07-2017	83.5369	20-09-2017	87.0262	20-11-2017	85.9331
16	24-07-2017	83.8164	21-09-2017	87.1547	21-11-2017	86.1892
17	25-07-2017	83.8778	22-09-2017	88.3061	22-11-2017	85.8523
18	26-07-2017	83.8308	25-09-2017	87.9367	23-11-2017	86.3327
19	27-07-2017	84.2109	26-09-2017	88.0744	24-11-2017	86.0364
20	28-07-2017	83.8867	27-09-2017	88.1426	27-11-2017	86.1605
21	31-07-2017	84.1591	28-09-2017	87.9808	28-11-2017	85.8469
22	1/8/2017	84.6214	29-09-2017	87.7067	29-11-2017	86.1428
23	2/8/2017	84.6416	3/10/2017	86.8707	30-11-2017	86.798
24	3/8/2017	84.1589	4/10/2017	86.6266	4/12/2017	86.636
25	4/8/2017	83.7074	5/10/2017	86.2145	5/12/2017	86.6378
26	7/8/2017	83.1583	6/10/2017	85.3112	6/12/2017	86.4939
27	8/8/2017	83.1465	9/10/2017	85.6311	7/12/2017	86.3142
28	9/8/2017	82.9248	10/10/2017	85.9412	8/12/2017	87.0405
29	10/8/2017	83.0053	11/10/2017	86.1161	11/12/2017	86.3282
30	11/8/2017	83.2661	12/10/2017	86.2319	12/12/2017	86.0466
31	14-08-2017	83.2777	13-10-2017	86.3051	13-12-2017	85.941
32	16-08-2017	82.6162	16-10-2017	86.0082	14-12-2017	86.3535
33	18-08-2017	82.6183	17-10-2017	86.0354	15-12-2017	86.1319
34	21-08-2017	82.3983	18-10-2017	85.7425	18-12-2017	85.5437
35	22-08-2017	82.5992	23-10-2017	85.8381	19-12-2017	85.7932
36	23-08-2017	82.2303	24-10-2017	85.7927	20-12-2017	85.7604
37	24-08-2017	81.9361	25-10-2017	85.4814	21-12-2017	85.6284
38	28-08-2017	82.3605	26-10-2017	85.884	22-12-2017	85.6739
39	29-08-2017	82.8833	27-10-2017	85.3826	26-12-2017	85.672
40	30-08-2017	82.6209	30-10-2017	85.375	27-12-2017	85.8366
41					28-12-2017	86.221
42					29-12-2017	86.0653

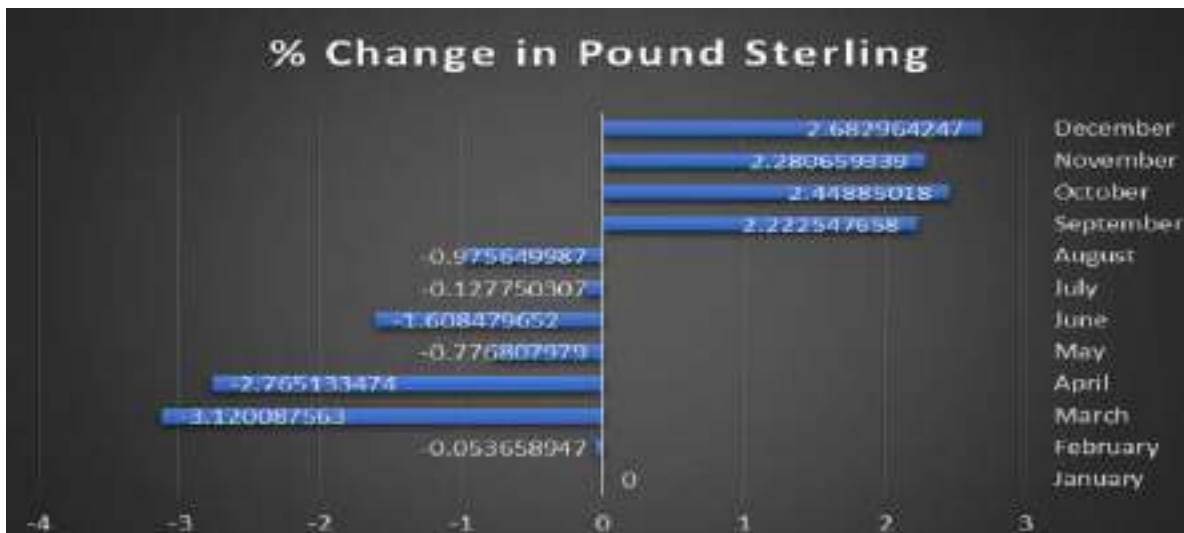
Calculation of monthly average rates of Pound Sterling

Average monthly rate = sum of rates / no of days in a month

Percentage change in Pound Sterling (monthly): = current month rate –base rate / base rate



Monthly Average Rates of pound sterling (January - December 2017)		% change in pound sterling	
January	83.86150476	0	0
February	83.81650556	-0.000536589	-0.053658947
March	81.24495238	-0.031200876	-3.120087563
April	81.54262222	-0.027651335	-2.765133474
May	83.2100619	-0.00776808	-0.776807979
June	82.51260952	-0.016084797	-1.608479652
July	83.75437143	-0.001277503	-0.127750307
August	83.04331	-0.0097565	-0.975649987
September	85.72536667	0.022225477	2.222547658
October	85.91514737	0.024488502	2.44885018
November	85.7741	0.022806593	2.280659339
December	86.11147895	0.026829642	2.682964247



#### Interpretation:

The above table and bar diagram showing monthly average rates and % change in value of currency 2017. The value of January 2017 is considered as base rate which is 83.86150476. There is a slight decrease in February, May, July and August. There is a highest decrease at 3.12% in March. There is a decrease of 2.76% & 1.6% in April and June respectively. There is an increase of 2.2% to 2.68% from September to December.

**Euro:** The euro (sign: €; code: EUR) is the official currency of the European Union. Currently 19 of 28 member states use the euro (Eurozone). It is the second most traded currency in the foreign exchange market after the dollar. The euro is subdivided into 100 cents. The European Commission then chose the design created by the Belgian Alain Billet. Of the symbol, the EC stated. Inspiration for the € symbol itself came from the Greek epsilon (€) [note 14]


**Exchange rate of EURO ( 1-01-2017 to 31-12-2017) with reference to Indian rupee**

S.NO	Date	EURO	Date	EURO	Date	EURO
1	2/1/2017	71.5121	2/3/2017	70.3074	4/5/2017	69.9392
2	3/1/2017	71.3818	3/3/2017	70.3509	5/5/2017	70.5972
3	4/1/2017	70.9949	6/3/2017	70.7346	8/5/2017	70.4957
4	5/1/2017	71.5574	7/3/2017	70.5595	9/5/2017	70.4669
5	6/1/2017	71.8662	8/3/2017	70.4011	11/5/2017	70.1472
6	9/1/2017	71.8206	9/3/2017	70.3229	12/5/2017	69.8859
7	10/1/2017	72.182	10/3/2017	70.6426	15-05-2017	70.1332
8	11/1/2017	72.3213	14-03-2017	70.4354	16-05-2017	70.5539
9	12/1/2017	72.2322	15-03-2017	69.6224	17-05-2017	71.1598
10	13-01-2017	72.475	16-03-2017	70.1893	18-05-2017	71.6214
11	16-01-2017	72.4155	17-03-2017	70.6074	19-05-2017	72.2955
12	17-01-2017	72.5014	20-03-2017	70.3779	22-05-2017	72.2333
13	18-01-2017	72.5968	21-03-2017	70.295	23-05-2017	72.7489
14	19-01-2017	72.5194	22-03-2017	70.7206	24-05-2017	72.473
15	20-01-2017	72.7319	23-03-2017	70.6688	25-05-2017	72.4692
16	23-01-2017	73.1498	24-03-2017	70.4656	26-05-2017	72.3329
17	24-01-2017	73.2347	27-03-2017	70.6739	29-05-2017	72.1354
18	25-01-2017	73.0901	29-03-2017	70.1061	30-05-2017	71.8338
19	27-01-2017	72.7467	30-03-2017	69.8739	31-05-2017	72.143
20	30-01-2017	72.9621	31-03-2017	69.2476	1/6/2017	72.4518
21	31-01-2017	72.5526	3/4/2017	69.2788	2/6/2017	72.2673
22	1/2/2017	72.9154	5/4/2017	69.4017	5/6/2017	72.4886
23	2/2/2017	72.7966	6/4/2017	69.3912	6/6/2017	72.5178
24	3/2/2017	72.4429	7/4/2017	68.559	7/6/2017	72.6588
25	6/2/2017	72.4035	10/4/2017	68.2503	8/6/2017	72.5092
26	7/2/2017	72.0716	11/4/2017	68.3067	9/6/2017	71.9823
27	8/2/2017	71.8759	12/4/2017	68.6706	12/6/2017	72.1324
28	9/2/2017	71.5423	13-04-2017	68.6193	13-06-2017	72.1465
29	10/2/2017	71.3344	17-04-2017	68.4049	14-06-2017	72.1283
30	13-02-2017	71.1718	18-04-2017	68.7431	15-06-2017	72.1094
31	14-02-2017	71.0877	19-04-2017	69.1915	16-06-2017	72.0482
32	15-02-2017	70.8207	20-04-2017	69.3355	19-06-2017	72.1043
33	16-02-2017	71.0239	21-04-2017	69.1675	20-06-2017	71.9583
34	17-02-2017	71.5053	24-04-2017	69.9884	21-06-2017	71.9413
35	20-02-2017	71.056	25-04-2017	69.8569	22-06-2017	72.0732
36	22-02-2017	70.5403	26-04-2017	70.043	23-06-2017	72.0808
37	23-02-2017	70.5444	27-04-2017	69.8908	27-06-2017	72.1921
38	27-02-2017	70.5149	28-04-2017	69.8809	28-06-2017	73.3757
39	28-02-2017	70.7151	2/5/2017	70.0436	29-06-2017	73.5233
40	1/3/2017	70.5716	3/5/2017	70.0323	30-06-2017	74.0019



S.NO	Date	EURO	Date	EURO	Date	EURO
1	3/7/2017	73.8567	31-08-2017	76.0439	31-10-2017	75.4234
2	4/7/2017	73.5995	1/9/2017	76.1047	1/11/2017	75.0755
3	5/7/2017	73.5035	4/9/2017	76.1516	2/11/2017	75.2831
4	6/7/2017	73.4322	5/9/2017	76.2921	3/11/2017	75.3348
5	7/7/2017	73.8811	6/9/2017	76.5438	6/11/2017	75.1801
6	10/7/2017	73.5826	7/9/2017	76.3593	7/11/2017	75.2273
7	11/7/2017	73.4361	8/9/2017	77.0357	8/11/2017	75.3841
8	12/7/2017	73.9715	11/9/2017	76.7334	9/11/2017	75.3061
9	13-07-2017	73.7884	12/9/2017	76.5514	10/11/2017	75.7356
10	14-07-2017	73.5677	13-09-2017	76.663	13-11-2017	76.2161
11	17-07-2017	73.6933	14-09-2017	76.1398	14-11-2017	76.4781
12	18-07-2017	74.1469	15-09-2017	76.3995	15-11-2017	77.0634
13	19-07-2017	74.2265	18-09-2017	76.4923	16-11-2017	76.9981
14	20-07-2017	74.188	19-09-2017	77.0187	17-11-2017	76.5574
15	21-07-2017	74.8796	20-09-2017	77.2493	20-11-2017	76.3633
16	24-07-2017	75.1287	21-09-2017	76.7403	21-11-2017	76.3878
17	25-07-2017	75.0607	22-09-2017	77.7566	22-11-2017	76.0757
18	26-07-2017	74.9214	25-09-2017	77.3036	23-11-2017	76.6264
19	27-07-2017	75.2082	26-09-2017	77.431	24-11-2017	76.7213
20	28-07-2017	74.9829	27-09-2017	77.3686	27-11-2017	77.1421
21	31-07-2017	75.2203	28-09-2017	77.1764	28-11-2017	76.6992
22	1/8/2017	75.7415	29-09-2017	77.0603	29-11-2017	76.3209
23	2/8/2017	75.7488	3/10/2017	76.7756	30-11-2017	76.4887
24	3/8/2017	75.3905	4/10/2017	76.8266	4/12/2017	76.3739
25	4/8/2017	75.6609	5/10/2017	76.5685	5/12/2017	76.3762
26	7/8/2017	75.1019	6/10/2017	76.2641	6/12/2017	76.2791
27	8/8/2017	75.2876	9/10/2017	76.599	7/12/2017	76.0848
28	9/8/2017	74.8606	10/10/2017	76.8302	8/12/2017	75.7978
29	10/8/2017	75.0635	11/10/2017	77.1677	11/12/2017	75.8051
30	11/8/2017	75.4567	12/10/2017	77.2741	12/12/2017	75.9292
31	14-08-2017	75.7035	13-10-2017	76.8772	13-12-2017	75.7768
32	16-08-2017	75.3761	16-10-2017	76.3912	14-12-2017	75.998
33	18-08-2017	75.2078	17-10-2017	76.4204	15-12-2017	75.5241
34	21-08-2017	75.2143	18-10-2017	76.5423	18-12-2017	75.4277
35	22-08-2017	75.6497	23-10-2017	76.5136	19-12-2017	75.6365
36	23-08-2017	75.4072	24-10-2017	76.3395	20-12-2017	75.8251
37	24-08-2017	75.5805	25-10-2017	76.59	21-12-2017	76.0344
38	28-08-2017	76.2162	26-10-2017	76.6063	22-12-2017	75.8821
39	29-08-2017	76.7505	27-10-2017	75.6837	26-12-2017	76.0255
40	30-08-2017	76.4504	30-10-2017	75.4271	27-12-2017	76.2258





Monthly Average Rates of Euro (January - December 2017)		% Change in EURO	
January	72.32592857		
February	71.46459444	-0.011909064	-1.19090642
March	70.34164286	-0.02743533	-2.743532995
April	69.16556111	-0.043696189	-4.369618922
May	71.22577619	-0.015211037	-1.521103707
June	72.41388095	0.001216056	0.121605602
July	74.20360952	0.025961381	2.596138051
August	75.595605	0.045207528	4.520752783
September	76.78911429	0.061709345	6.170934549
October	76.48002632	0.057435802	5.743580244
November	76.12114091	0.052473745	5.247374507
December	75.99746842	0.050763812	5.076381212



**Interpretation:**The above table and bar diagram showing monthly average rates and % change in value of currency 2017.the value of January 2017 is considered as base rate which is 72.32592857. There is a decrease of 1.19% in February. Which raised to 2.74% in March and 4.36% in April and fall in May at 1.52%. The value of EURO has increased by 0.12% in June. There is a positive increase in EURO at 2.59% in July and 4.5% in august. There is a highest increase in September at 6.17%. And 5% to 5.74% increase in October November and December.

**FINDINGS**

Based on the above computation it is found that the foreign exchange monthly average rates and their respective % changes vary every month.

1. The US Dollar is decreasing from February to December That is 1.47% to 6.03%.
2. The value of pound is decreasing in first seven months (February to August) i.e. 0.05% to 3.12%. later increased in next four months from September to December i.e. 2.22% to 2.68%
3. The value of Euro is decreasing in first four months from February to May i.e. 1.19% to 4.36%. the value of euro has started increasing from June. And there is a positive change in value till December i.e. from 0.12% to 6.17%.
4. The value of US Dollar in all the months has decreased as compared to pound currency in first seven months the rates has decreased after ward in next four months the rates are increasing and in euro first four months value is decreasing and there is a very good improvement in euro rate in next seven months the rates has increased.



## CONCLUSION

Based on the above findings it is clear that the exchange rates keeps changing at regular intervals. At the time of investment we should consider proper risk evaluation techniques.

\*\* US Dollar is decreasing from the start of January 2107 till December 2017.as the value of the currency is decreasing it is quit risky to invest in US Dollar

\*\* Pound sterling value is decreasing from start i.e. February to august and increasing from September to December.As the value of the currency is fluctuating the decision making process regarding investment becomes difficult.

\*\* The value of EURO is Rs72.325/Euro in Januarywhich is decreasing from next month that is February till May. And increasing from June to December. As the value of the currency is fluctuating the decision making process regarding investment becomes difficult.

\*\* As the values of the currency keeps fluctuating it becomes necessary to properly analyze the foreign exchange risk for making investment decision.

## BIBLOGRAPHY

### WEBSITES

- 1.<https://www.rbi.org.in/>
- 2.<https://www.wikipedia.org/>
- 3.<https://www.investopedia.com/>

### Books

1. *International financial management- P.G. Apte*
2. *International financial management- Prasanna Chandra*



## ARCHAEOLOGICAL MONUMENT OF UCHTEPA-BULAKMAZAR - AS A NEW TOURISM SITE OF NAMANGAN REGION

<sup>1</sup>Asqarorov Qahraman, <sup>2</sup>Tukhtasinov Dilshot, <sup>3</sup>Rahmonov Ulugbek,

<sup>1</sup>Assistant of Professor

<sup>2</sup>Teacher

<sup>3</sup>Master Student

Namangan State University

### ANNOTATION

*In this article the archeological monument of Uchtepa-Bulakmazar located in Narin district of Namangan region and archeological excavations in its territory are analyzed. The main focus of the article is on the history of the monument, the process of its transformation into a shrine, the archeological excavations carried out in 2019-2020 on the site and the scientific results obtained as a result.*

**KEYWORDS:** *Archaeological monuments, excavations, findings, Uchtepa cemetery, tourism, Namangan region, sites of cultural heritage, pottery dishes, shrine.*

In connection with the introduction into the state program “Obod qishloq” in 2019 year in Uchtepa village of the Naryn district of Namangan region, it began to study the archaeological monuments located in the village. The research work was carried out excavations at the archaeological site “Uchtepa 2” from April 2019 year to the end of October. The archaeological object “Uchtepa 2” studied is an archaeological monument consisting of layers of culture that have been completely exposed to bad poristiy) state for centuries under the influence of salt and moisture, as well as the roughness of the roots of clover and reeds, and in the process of digging it extraordinary unique finds related to the religion of fire-worship up to the Islamic, in the end, this object turned out to be a temple of Zarathustra.

Indeed, in the process of digging up the ruins of the synagogue, very rare finds were found. In particular, among the findings are more than 40 fire worship altar kilns, more than 20 stone devices-altars, dozens of different periodical sacred stone knives (jertvennie noji) made for slaughter of sacrificial animals, several different types of sanam-goddesses made of stone, many of which are related to the fire worship religious believe, evidence of the divine-cult used in the preparation of the holy, thousands of pieces of ceramic pots made of professionally highly elegant in the charm of slavery (among them there are also archaeological bus-buttons), graves of some shrines monks, tissues of the

waist belt made of iron from the waist part of grave skeletons, bone fragments of the sacrificial animal and ceramic dishes placed next to them with an iron knife and food.

In the process of clearing and encrypting them from the soil on a piece of ceramic and on the body of a number of stone goddesses, the oldest inscriptions with inscriptions inscribed in the form of a cuneiform alphabet and pictures of heavenly gods and parishes of tolerance with fire worked schematic fossils, in some of them pictures of animals and fish are drawn, because these findings testify to the fact that among the ancestors of the indigenous population of the Fergana Valley, was a literate and highly experienced painter in the aramaic script 2 thousand years ago. Such a unique monument of antiquity was not met before not only in the Naryn district, but also in any region or district of the ancient Fergana.

Thus, this temple of Zarathustra is a universal religious-ideological center in which our ancestors worshiped the ancient Fergana (Chinese Davan-Dayyuan, in sugd - Pargana) state until the Islamic religion of one of the local governorates, and such a monument is being fully revealed for the first time in the Namangan region.

The fountain complex “Uchtepa 2” is a very unique and delicate object in reality. This place is an object where two world religions collide in terms of ideological significance. The monument was erected



at the beginning of the BC century. At the beginning of the 8th century BC, the eastern regions of the Arab Caliphate were destroyed by the unique Kutayba ibn Muslim where the town of Movarounnahr and the local fire-fighting and idolatry temples of the townships were destroyed. So, during these military and religious walks of Kutayba (now this place is the village of Uchtepa of the Naryn district) in the Haylam city of the ancient Fergana Miyon Rudoh area, this fire temple is also destroyed.

In those, Kutayba came with his troops and gained fame in the chapter of introducing the firemen to the Islamic religion, the Prophet Qurayish mother remembers the name with respect to the old Uchtepans so far. And the fountain cemetery, which is located near the double boiling fountain, is formed due to this mother-in-law's grave, thanks to her followers.

The temple of fire worship "Uchtepa 2" is located in the historical topography of the capital Khaylam of the area of Miyon Rudoh, a part of the ancient city, in its part of Shahristan. 500 meters from it were raised in the east, in ancient times, on the banks of the boiling spring, the summer palace (residence) of the mayor of the city 2000 years ago ("Uchtepa 1"). Its salty pressing galvirak reminds the middle of the devastation, which turned into saline, a sedimentary grounding. In the future, it is planned to also dig it and add it to the range of tourist facilities.

Unfortunately, in the following years, a two-hill between and a large western square of the old city were built, and a complex of archaeological monuments of Uchtepa Bulakmazar lost the appearance of its ancient city. The area of the hill "Uchtepa 2", where the old city was kept to us, is about 0,50 ha it is also at its periphery that the inhabitants of the village were annexed to the courtyard, the highest, two-thirds were preserved. According to the remains of an architectural device and finds uncovered during the excavation, this top turned out to be a sacred temple of worship to the sun of the inhabitants of the ancient city. After the invasion of the shrine Arabs, in its ruins, the city's total Islamic mosque was not built, this place remained in ruins and remained as an ordinary hill until us.

At present, the hill "Uchtepa 2" began to form from the end of the VIII century BC, and has joined the village cemetery, which continues to this day.

In the study of the monument, it was first installed a rafter pile on its highest point, the upper part of the central square of the top was turned out to be square sets of 2x2 meters. The area of each square was cleaned from saline solution to a depth of 1 meter. From the cleaned area neither the remains of drying, nor pieces of earthenware were met. Then the top area was divided into 4, and they were also

cleaned from the salty finely ground one by one. Especially it turned out that the north and north-east sides of the tepachani were turned into a dump by the surrounding population. During the cleaning of this part of the hill from the garbage, it was determined that these sides of it were demolished to the mainland, and the corresponding cultural layer was preserved due to various end-period farm devices.

After that, in order to determine the age of the monument, to study the formation in the chronological sequence of the cultural layers contained in the monument, a stratigraphic shurf and a tranche were dug in two places of it.

Stratigraphic shurf was excavated on the north-west side of the hill, on the border of the hill at 3,5x2,40 meters. Its depth is 1,70 cm from the current earth satchel to the mother earth (mainland) layer. The mother earth-mainland layer consists of light brown soil, on which is located a humus cultural layer. In this layer, fragments of earthenware, angobled in a clear red color, and fractures of animal bones were found in the remains of the altar furnace. Above it is located a cultural layer of yellowish soil with a thickness of 1,30 cm. In the structure of this layer were found pieces of ceramic angobled in to'qqizil and light red colors, fragments of moldy ceramic cauldron, burnt charcoal and pet bone. Angobled ceramic fragments are made of a very thin stencil, in bondage chariot. The surface of the upper part of the excavation was freshly pressed grass.

The stratigraphic transheya was placed southward by the north of the hill. Its length is 10 m., width is 1 meter. At the intersection of transheya, the layers of pakhsa and khomgisht from north to south crossed mixed cultural layers and fell to 4 meters, at its southern adage 2 m. at a depth of 7 meters in distance, the mainland was opened.

As it turned out, the temple Loy was densely well processed, built on a platform with a thickness of about 1.5 meters. The cultural layers of the transheya cross section last from the digging surface to 5-5, 5 meters. In the structure of the platform, archaeological artifacts have not been encountered, it is reminiscent of an azure mud rich in reed roots.

At the bottom of the cultural layers of transheya were found fragments of ceramics and animal bones belonging to the antiquity and at the upper cross section to the early middle ages. 8,70 m along the length of the western stencil from the northern start (border) of the transheya distance, 5,5 m at the depth, an altar-oven, built in the form of a circle, was opened. The diameter of the altar is 90 cm., its reservoir is full of ash in white. Among the ashes were found fragments of earthenware, angobled in a clear red color. This altar-oven should belong to the first stage of the temple.



When studying the composition of stratigraphic strata, it was difficult to observe in its cross-section the chronological sequence of the platform and cultural layers, that is, in the cross-section of transheya it was very difficult to distinguish cultural layers from each other. Because the structure of the soil of the object, the soil from which it was built, the silt, which was used in its construction, was salted, the silt mud and the soil from which it was excavated, was full of reeds and clover roots, and for centuries these reeds and clover roots came out and completely covered the body of the flank vessels grew in size and even ruptured the temple atashkades from all over, causing great damage to the preservation of the cultural layer and its structures. Those same wild grass-plant revival saw great damage due to the walls of the synagogue and cultural layers, and the preservation of the walls also reached us in the sift state, as reflected in the cross section of the scientific laboratory. Do not open what part of the hill and clean it like a mirror, 3-4 days later the roots went deep, the clover and reed shoots began to grow. The opened area is salted. This condition is also noticeable in the cut of the trachea.

Another of a number of important tasks before the scientific expedition was the identification of the main ideological plan of the ancient engineer in the construction of the temple by archaeological excavations.

Archaeological excavations carried out at the monument, observations showed that in reality the primary foundation thickness of the temple is 1,5 m. it is built on the platform around it. The initial platform area is rectangular in shape, surrounded by a thick defensive wall. Later, this fact was observed on the southern side of the hill (this fact was observed), when two mirza walls were glued to it from outside the fence.

As a result of the excavations, it was found that the central door to the entrance to the temple was on its north side, which was as a thick-walled corridor. The eastern wall of the corridor has a fundamental character. The corridor opened at a length of 6 meters. The length of the corridor did not open to the central part of the temple, to the hall, which is located on the main atashka. (Because the hill part of the temple up to the central hall has not yet been studied).

Also on the issue of the western wall of the corridor is a problem, it has not yet been determined what width it is. Because the western "Wall" of the corridor does not have such a fundamental composition as the eastern wall. The border of the extreme western wall dates back to the eastern border of the stratigraphic tranche.

During the archaeological excavations, a number of stone devices were opened, from the well-

preserved upper part of the cultural layers of the temple, on the same horizontal plane, along its circumference in the form of a circle and an oval. They found fragments of ceramics belonging to the early middle ages from inside and around them. From them came out low-walled altar-ovens, which were built in the form of an oval, rectilinear and a circle, from 50-60 cm lower than the grass. Among them were met exquisite ceramic fragments with clear red and dark angobles, subjects related to the cult of fire – worship, stone parrots, schematic stone goddesses. Almost the majority of altar-ovens are located in rooms that surround the western, northern, eastern and partly southern sides of the central square of the temple.

## REFERENCES

- 1.Q. Asqarov. *Uchtepa Buloqmozor arxeologik yodgorligi. "Vodiynoma".-Andijon 2019, № 2 (12)*
- 2.Q. Asqarov. *Dastlabki izlanishlar Uchtepa Buloqmozor arxeologik majmuasida zardushtiylikka ishora. R.H.Sulaymenovning 80 yillik yubleyiga bag'ishlangan xalqaro ilmiy-amaliy konferensiya materiallari. – Toshkent. 2019*





## ORGANIZATION OF GARDEN PLOT SERVICE CLUSTERS – DEMAND OF PERIOD

<sup>1</sup>Mahkamov Ibroyim, <sup>2</sup>Shakhobov Hamidjon Mukhamadovich

<sup>1</sup>Assistant of Professor, Namangan Institute of Engineering and Technology

<sup>2</sup>Base Doctorate, Namangan Institute of Engineering and Technology

### ANNOTATION

*This article addresses the socio-economic reforms carried out in our country. Important and country-specific features of ensuring employment and raising living standards have been highlighted. Issues of garden plot management and their productive use in rural areas are described. Attention is paid to the issue of solving the problem of poverty. In particular, in the Namangan region described the peculiarities of solving the problem of poverty through the development of garden plot farms.*

**KEYWORDS:** *garden plot farms, poverty, prosperity, living standards, unemployment, employment, entrepreneurship, cluster, pandemic, credit, greenhouse, capacity, territory, garden plot service.*

The pandemic, which is leaving a complication mark in the world economy, is taking its toll on economic sectors at all stages, ranging from large enterprises to small businesses and private businesses. In order to prevent such negative consequences, a new system of entrepreneurship support and development has been created in our country and introduced into practice.

Due to the conditions created by our state, the number of people wishing to engage in entrepreneurial activity is growing. In particular, they are engaged in horticulture, fruit and vegetable growing, gardening, bee-keeping, livestock, poultry, fishery, farming, Service and other areas due to the characteristics of the territory. From these it can be seen that attention is paid to the development of family entrepreneurship, especially garden plot. This is not only a socio-economic task, but also a political goal aimed at dramatically increasing the interest of our people in changing the world outlook, earning through labor. Therefore, in the following years, a number of laws, decisions and normative documents were adopted by the state on the effective use of population farms, some amendments were made to the laws. The position of the president of the Republic of Azerbaijan was introduced at the meetings of local citizens.

In addition, the council of farmers, peasant farms and landowners of Uzbekistan, as well as its regional divisions were established. 224 “Garden plot

services” enterprises on the provision of seeds and seedlings and provision of chemicals have been established in 350 billion soums were allocated from the state budget for the implementation of new projects in the garden plot, and the fund's activities were launched at the meeting of the board of directors. Due to today's demand, the Ministry of economic development and poverty reduction was established. From this it can be seen that a new system has been introduced that will help the population, supply and finance material resources, which were not before. As a result of the creation of a system that works with garden plot, supplies material resources, finances and controls crop rotation, the number of families receiving abundant yields and high incomes from garden plot is growing steadily.

The organization of services such as the plowing of garden plot of the population, the supply of necessary seeds and seedlings, the construction of a compact greenhouse for households and the supply of sheep, goats, poultry, bees nests, rabbits was established through the enterprises of "farm services".

Since all conditions have been created by the state for the development of garden plot farms, it would not be a mistake to say that today the productive use of these opportunities has become a necessity and an obligation. Because at a time when the pandemic of coronavirus threatens the entire world, the development of garden plot is becoming a



more serious issue. On this issue, on April 8, 2020, the results of the work on the areas in the fight against the coronavirus pandemic under the chairmanship of President Sh.Mirziyoyev were also touched upon at the video-vector meeting dedicated to the development of the garden plot, which is an important source of ensuring food security, increasing employment and income of the population. The issues of delivering the products grown in it to the domestic and foreign markets were also considered. As a result of the systematic work carried out by 81 "Garden plot services" LLC, along with the supply of farm-grown vegetables bulwair peppers, onions, greens, legumes and oil crops, melons and dried fruits to domestic markets, export to foreign countries, in particular to dozens of countries such as Afghanistan, Iran, Kazakhstan, Russia, Latvia.

In order to fully meet the demand of our people for fruit and vegetable products throughout the year, to deliver them to the population in a well-preserved state, the establishment of field shops in densely populated areas, frozen warehouses that store agricultural products and their processing, in other words, the establishment of clusters of "Garden plot services" is becoming.

On the initiative of the president of our country, clusters based on the chain method of cultivation and deep processing of products in agriculture are launched. This creates opportunities for employment and regular income generation by creating new jobs for the rural industry.

According to today's data, more than 5.5 million farmers and landowners operate in our country using 502 thousand hectares of land.

It can be seen that since a significant part of the main crop areas is at the disposal of the population, it is necessary to formulate the ability to effectively use the opportunities available to their owners. To this end, in the following years, the mechanism of effective use of peasant farms and garden plot land plots and the stimulation of landowners who have achieved this has been introduced.

Paragraph 2 of Article 3 of the law "on garden plot management" adopted on April 1, 2021 does not consider garden plot entrepreneurial activity and does not require state registration of garden plot. A person who independently carries out activities based on participation in the farm with his personal labor on the cultivation (processing) of agricultural products in the farm can receive the status of a self-employed person in accordance with the procedure established by the legislation on employment of the population.

It turns out that the law further strengthens the social protection of landowners, as well as their

property rights and their status as an economic entity. Because in it, the rights of the landowner, regardless of the form of ownership, to enter into contractual relations with all types of economic entities for their activities were determined individually. And this confesses that the majority of the population is not only a source of earning a living on their farm, but also a means of doing business and earning more through it.

In 2020, the experience of establishing the activity of clusters of "Garden plot services", which includes 12 types of activities, gave a positive effect.

In accordance with the resolution of the president of the Republic of Uzbekistan dated June 30, 2020 "on additional measures to increase the effectiveness of the use of population farms", the activities of cluster enterprises on the basis of 20 LLC "Garden plot services" in the Republic were launched. It is planned that this process will continue in 2021 year, and in 32 districts where a lot of fruits and vegetables are grown, in particular in the Yangikurgun, Chust, Chartak, Uychi and Kosonsoy districts of Namangan region, the operation of Farm Service clusters will be launched. In order to carry out these works, 58 billion soums will be allocated from the savings account under the Council.

The amount of cultivation of competitive products is increasing due to the combination of peasant farms and population farms to the enterprises of the established garden plot cluster and the establishment of economic relations between them, and the possibilities of additional income of the population are also becoming more and more. Because the updates in the cluster activity, the introduction of innovative technologies, soon show their effectiveness. The clusters established on the basis of LLC "Garden plot services" include the complete process from the purchase of seeds, seedlings from the delivery to the delivery of seeds for the cultivation of products in the population farm and from it to the production of the final product, and this protects the owners of the farm from the market risk. Because they do not meet unknown buyers in the market, the cost of carrying the product to the market is saved.

Like all regions of our country, a program of measures for the development of garden plot farms has been created in the Namangan region. In the region there are 252.0 thousand hectares of irrigated land, of which 31.9 thousand hectares constitute population farms. Due to today's requirements, the main emphasis is on the effective use of garden plot land. Because, the majority of the population of the region lives in rural areas and a certain layer of them constitute low-income poor families.

In a number of districts of the region there are exemplary garden plot farms, which can be



sampled from 8-10 acres of garden plot to 2-3 times a year and 50-60 million soums, while some families can be sampled to other families with an income of more than 100 million soums.

According to the 53-th resolution of the Cabinet of Ministers of the Republic of Uzbekistan in 2020 30 January, Naryn, Uychi, Turakurgan, Namangan district governors jointly organized practical and visual seminars on the effective use of exemplary practices of farmhouses in the districts on the principles of "garden plot source of income", "one neighborhood one product", "from field to table".

Based on the above points, it can be said that taking into account the complex situation that has arisen due to the coronavirus pandemic, sowing 2-3 times in all farms and obtaining additional dressing is today one of the first tasks. The construction of compact greenhouses by taking into account these also plays an important role.

Last year 2670 modern greenhouses were created in Namangan region. These works are continued in 2021 year and in each district it is planned to build a total of 4.4 thousand light construction greenhouses in the population apartments on the territory of 300-500 of them, 527 of them have been built and put into operation to this day.

In 2020, our President Sh.Mirziyoyev during his visit to Namangan region in June 2020, gave a series of instructions on social protection to ensure employment of autonomous, unemployed, low-income, poor families and obtaining permanent source of income in order to get acquainted with major projects, communicate with population. On the basis of these instructions, the project "in one place-a thousand family greenhouses" was implemented in cooperation with the Ministry of employment and labor relations of the region. In particular, in the Chartak district of Golden Nats Namangan Agro network service LLC, in the high hill steppe 36 hectares of unused land for many years were built 2 thousand greenhouses each. 6.7 billion soums of subsidy and 6.3 billion soums of preferential credits of commercial banks were allocated to the project with a total value of 13 billion soums from the fund of employment promotion.

According to the studies, in these greenhouses on the basis of the principle of "one neighborhood-one product, quality products meeting the demand of foreign countries are grown. Another of the benefits is that seedlings, water, mineral fertilizers and market supply in the cultivation of the product are guaranteed by the leading entrepreneur. Dressing in greenhouses can be grown up to 3 times a year. According to experts, 700 bush of tomato seedlings are planted in one greenhouse. each bush

can take 4-5 kilograms of dressing from seedlings. Let's say, if the average price of 1 kilogram of tomatoes (in the corresponding months) is 3 thousand rubles, then the first harvest can be made from itself an income of 7-8 million rubles.

To reduce poverty is to awaken the entrepreneurial spirit in the world, to fully realize the inner strength and dignity of man, to implement socio-economic policy on the creation of new jobs... It is necessary to give priority to the support of entrepreneurship, initiative, especially youth and women entrepreneurship on the solution of social problems in the localities, the president said. Sh.Mirziyoyev spoke at a meeting with activists of the Namangan region in June 2020.

As the experience of today shows, it is necessary to exclude axoli from poverty by ensuring employment, obtaining regular income from them. Because more than 24 thousand 300 poor families, 57 thousand more unemployed people were taken into account in the region. Taking into account these, a program of measures to ensure the employment of population for the organization of various forms of entrepreneurship in the districts was developed in 2020-2022 years. In this regard, the work carried out in the districts of Chartak, Turakurgan, Uchkurgan and Uychi can be cited as an example. In particular, at the beginning of 2020 in the district of Uychi, 1920 thousand poor families were registered, measures were taken to ensure their employment and on this basis to obtain permanent income. Today, deputies of the district council formalized the study of each family, as well as relevant acts, and 1052 families were removed from the list of poor families by the decision of the session. As a result, 868 families remained on the list of poor families.

These poor families were given black cow for 79, sheep for 212, poultry for 108, bees for 2 and land for rent for 13. 86 families were given to build greenhouses. Also, 169 people were provided with permanent jobs, 2 with medicines and 47 with cash. From this it can be seen that in the district practical assistance is provided to each citizen in the implementation of the tasks set out in the program of expulsion from poverty.

According to the program "Each family is entrepreneur", a total of 895 citizens (46 of which are legal entities) were allocated 18 billion 149 million soums of credit by Agrobank and people's banks in the district for the purchase of livestock, fisheries, greenhouses, horticulture and stalls.

As can be seen from the above information, the conditions for people to work, engage in entrepreneurship and earn income are being created Step by step. However, the opportunities created cannot be called productive in all regions of the region. In particular, it was found that there were



insufficient greenhouses in the population apartments in the districts of Turakurgan, Kosonsay, Uchkurgan, Chartak, Yangikurgan and fruit trees and vine seedlings were planted in the farms. This is stated by the president of Uzbekistan Sh.Mirziyoyev commented that in the current probationary period, it is necessary to assess the lack of sowing on the lands of the garden plot, as well as the neglected abandonment-treason against the land and the land. Because the coronavirus pandemic is evident in countries around the world that there are not enough policies and measures to deal with food insecurity.

Therefore, heads of regional, district governorship, farmer farms council, Ministry of cocktails, neighborhoods and people's reception houses should study the organization of greenhouses by entering into apartments in the regions and planting various crops, fruit trees and Vine seedlings in the farms and provide practical assistance in solving the existing problems.

President Sh.Mirziyoyev noted in his address to the Oliy Majlis and the people of Uzbekistan: in the field of poverty reduction, the attention of the chambers and local councils of the Oliy Majlis should be given to the assessment of the real situation in the regions, control over the implementation of the work carried out.

In general, each district and the governor of the city should develop a targeted program to reduce poverty in its territory within a month, and in the implementation of which the local councils in each quarter should provide the public account through the mass media. This issue should become the main criterion by which all the leaders will be given the task of the first degree and the evaluation of the work effect.

It should be noted that some people think that the assistance provided by the state and the preferential conditions created are permanent. People of such categories are given credit instead of raising money, raising pet animals, taking different pet products and satisfying their family and local market demand, while the money given to the pet on credit is used to satisfy their other extiuses by buying cheap pet. There are also cases when the given seedling does not sow fruit tree seedlings in time, and the planted ones also do not receive adequate care. Such negative cases arise from cases of non-repayment of loans granted by banks on time. Even some families do not dream of paying a loan at all. Goosebumps account for the fact that this loan is given to them as "favour". But in fact, a barked loan means an obligation, a responsibility. It means getting out of poverty by employing family members and earning on this basis. It's time to radically change the way the world views people in such a turbid, fattening mood.

Our President Sh.Mirziyoyev noted, "the most important factor for getting out of poverty should be the aspiration of a person, relying on his own strength, clearly striving for the goal".

Based on the above, we can say that the clusters that are currently being established in almost all sectors and sectors of the national economy are showing themselves in the creation of new jobs and in the production of finished products with high added value. Today, the clusters established on the basis of "Garden plot services" LLC cover the complete process from the supply of seeds, seedlings, chemicals, mineral fertilizers necessary for the cultivation of products in the population farm to the purchase, storage and reproduction of the product being grown, which ultimately means the creation of new jobs.

It is desirable to pay attention to the following in order to further develop the garden plot, which in our opinion is one of the main factors that will solve the socio-economic problems in the future, and on this basis get out of poverty.

Firstly, ensure unconditional implementation of the law, form and decisions on the development of garden plot from the end of our state. To identify the responsible persons who control their implementation and to carry out regular analysis of their account and to take appropriate measures to eliminate the shortcomings identified in this regard.

Secondly, regular study of the use of garden plot at the intersection of the local civil society gathering. Regular coverage of the experiences accumulated in the owners of the farmyard, where the sample operates, through the media.

Third, to ensure the stability of the activity of the clusters of seeds, seedlings, chemicals, mineral fertilizer suppliers to farm farms, fodder for livestock, veterinary services, that is, "Garden plot services".

Fourth, it is necessary to conclude contracts in advance with the buyer, keeper and processing enterprises of agricultural products grown in the quadruple, farmhouses, and ensure their timely strict implementation, that is, further improvement of the Organization of the cultivation of products by the cluster method.

Fifth, to carry out explanatory work among the population on the essence of the content, affidavits of clusters "Garden plot services". This is widely used in the media.

Secondly, "Garden plot services" LLC further expansion and stability of the activities of the joints, providing the export of products grown in the population farms.

Seventh, establishing timely repayment of loans granted by banks to families, applying economic penalties to citizens whose credit resources



have not been used purposefully and who have not returned on time.

Eighth, organization of practical and visual seminar on the principles of “garden plot source of income”, “one neighborhood-one product”, “from field to table”, in the section of regions. Regular coverage of sample farm activities and accumulated experiences through the media.

In summary, garden plot farms are becoming more important today in solving the problem of poverty through the provision of employment and regular income generation. In view of this, the activities of clusters of farm services are being launched for the sustainable development of farm farms, the purpose of which is to positively solve the socio-economic problems in our country.

## REFERENCES

1. “Томорқа хўжалиги тўғрисида”ги Ўзбекистон Республикасининг Қонуни. 2021 йил 1 апрель, ЎРҚ-681-сон (Қонун хужжатлари маълумотлари миллий базаси, 02.04.2021 й., 03/21/681/0264-сон)
2. Ўзбекистон Республикаси Президенти Ш.Мирзиёев раислигида 2020 йил 8 апрел кuni коронавирус пандемиясига қарши қурашда жойлардаги ишлар натижадорлиги тахлили ҳамда озиқ-овқат хавфсизлигини таъминлаш аҳоли бандлиги ва даромадини оширишнинг муҳим манбаси бўлган томорқачиликни ривожлантириш бағишланган видеоселектор йиғилиши материаллари “Халқ сўзи” 2020 йил 9- апрел.
3. Қишлоқ хўжалиги маҳсулотларини кўпайтириш-бугунги кунда энг муҳим масала “Халқ сўзи”, 2020 йил 29 апрел
4. Наманганнинг меҳнаткаш, фаол, илмли халқи яхши яшашга муносиб-Ўзбекистон Республикаси Президентини Ш.Мирзиёевнинг Наманган вилояти фаоллари билан учрашувнинг маърузаси. “Наманган ҳақиқати”, 2020 йил 1 июль
5. Президент Шавкат Мирзиёевнинг Олий Мажлисга ва Ўзбекистон халқига Мурожатномаси. Ўзбекистон Республикаси Президентининг расмий веб сайти. 29.12.2020 йил.
6. “Янги Ўзбекистон” газетаси. 2021 йил 16 апрель. 76-сони





# THE PROBLEM OF TRANSLATION OF PHRASEOLOGICAL UNITS IN THE LEARNING ENGLISH

**Akbarova Mohinur Alisher qizi**  
*Student, Fergana State University*

---

## ANNOTATION

*The article is devoted to the translation of phraseological units, which are one of the most important layers of vocabulary that a person who studies English as a foreign language.*

**KEYWORDS:** *phraseology, phraseological translation, phraseological units, phraseological combinations, idiom.*

---

Phraseology is a testimony to the brightness and color of the language. Phraseological units reflect the history of the people, the originality of their culture and life. The images laid down serve as a reflection of the national identity of the people, and therefore phraseological units often have a distinctly national character. Along with fully national phraseological units, there are many international phraseological units in the phraseology of different languages. Some idioms are preserved archaic elements - the representatives of previous eras.

There is hardly a language in the world that completely lacks the phraseological layer of vocabulary. The English language is no exception. In English literature, mass media, as well as everyday speech of native speakers, there is certainly a large number of various idiomatic expressions, Proverbs and sayings that present a certain complexity for the English language learner. Usually these stable expressions are easily translated into Uzbek, however, there are some that need clarification.

Often, when translating phraseological units, difficulties arise, since the phraseological unit must be translated as a whole undivided unit - the sum of the values of units, but not as separate words. So, when using stable expressions, it is not desirable to remove words, change the word order in them, replace or add words, so as not to lose the true meaning.

Phraseological units are semantically non-free phrases that are reproduced in speech as a whole in terms of semantic content and lexical and

grammatical composition [1]. Unlike words, an important feature of phraseological units is their evaluation. In addition, phraseological units are limited, they are lexically stable and retain a constant composition.

When learning English, special attention should be paid to the latter, otherwise called idioms, due to the fact that they have a large coefficient of "originality" and cause difficulties in translation. Phraseological splices are unmotivated and non-derivative, their meaning does not depend on their lexical composition and is not deduced from the values of the components, for example: beat the bucket, get into a mess, etc.

The special need to learn idioms begins to be felt at a certain stage of language development - speech without them, even correct, is dry and lifeless. As a rule, a common mistake is attributing idioms only to colloquial speech, sometimes they are confused with slang. However, idioms exist in any layer of speech (for example, literary, colloquial, and others), filling and permeating the entire language.

The term "idiom" itself comes from the Greek idioma - "feature", "originality". The term "idiom" was first used by the English linguist L.P. Smith. According to this author, the English term idiom corresponds to the French term idiotisme and is used to reveal the grammatical structure of combinations characteristic of the English language, the meanings of which often cannot be explained from the point of view of grammar and logic [2].



Idioms are units of a language that are stable combinations whose meanings are not motivated by the words that make them up, and the meaning of parts is not reduced to the meaning of the whole. Accordingly, an idiomatic expression is a phrase whose meaning is difficult, and sometimes impossible, to guess based on the meanings of its constituent words. If you translate it literally, it doesn't make sense.

There are words and expressions in English that cannot be translated without additional information. In the modern world, people can find such words when listening to songs, getting acquainted with creativity in General. Such lexical units may reflect the history of a country; for example, the idiom "It is not my cup of tea" means "it is not for me, not for my taste", something unacceptable for a person, not suitable for him. The history of the idiom is connected with the British love of tea. It is known that in 1930, another idiom was used: "It is my cup of tea" in a positive sense in relation to close people and issues of interest. However, after of years 1950 the meaning of the idiom changed due to the arrival of Americans on English lands. The British did not want and did not accept the culture and manners of the Americans, so they began to use the expression "not my cup of tea" in relation to them.

In modern English, this idiom is used only in a negative sense and its meaning is that it reflects the British rejection of any situations. It can express a negative attitude towards people, as well as inanimate objects or activities.

Many phraseological units are associated with legends and beliefs. Given example:

- "a black sheep" ("black sheep, shame in the family"). According to an ancient legend, a black sheep that appeared in a flock was considered a marriage and even marked with the devil's seal. This phraseology reflects a negative meaning. A scoundrel, a person who corrupts others, is compared to a black sheep;

- "an unlicked cub" ("green, yellow-faced youth; milk on the lips is not dry"). In the Middle ages, there was a belief that cubs are born shapeless and the bear, licking them, gives them the proper appearance. In modern English, it means "awkward teenager".

However, a large number of English phraseological units originate in professional speech.

There are several sources of phraseological units (idioms):

1. Professional speech ("to play the first fiddle", to occupy a leading position, position).

2. Folklore ("bell the cat" - to take responsibility in a risky business, to do the impossible - like the mice from the fable, who

wanted to hang a bell on the cat's neck to know about its approach).

3. Literary quotes ("between you and me and the bed-post", strictly confidential, only between you and me).

4. Biblioism ("a wolf in sheep's clothing", a person who seems virtuous and amiable, but hides his evil intentions under this guise).[3]

Translation of occasional (author's) phraseological units may also present a significant difficulty. This can be explained by the fact that most of them are emotionally rich, bright, peculiar turns that belong to a certain functional style and can have a pronounced expressive color.

Phraseological units can be divided into two groups based on the presence or absence of equivalents: phraseological units that have equivalents in the target language, and non-equivalent phraseological units.

There are absolute (full) and relative (partial) equivalents. Absolute equivalents coincide with English phraseological units in all respects - grammatical structure, lexical composition, meaning, and stylistic orientation. However, there are few such coincidences. This group includes international phraseological units based on historical facts, biblical legends and traditions, for example, the expression "the root of the trouble" - "the root of evil". Relative equivalents have grammatical and lexical differences with the same meaning of the same stylistic orientation, for example, "think tank" - "brain center".

It is worth adding that when translating phraseological units into Uzbek, different approaches are required in different situations. A person who translates an expression must feel like a part of a foreign language culture and find the only possible and unique way to translate it into Uzbek.

Over time, phraseological units become obsolete, but they are replaced by new, sometimes more vivid ones. It follows that the phraseology of the English language is developing, improving, acquiring new features, enriching itself and enriching the inner world of people.

Phraseology, which is an integral part and a treasure of any language in the world, undoubtedly contributes to this communion. When studying a foreign language, you cannot do without information about its original part of the vocabulary created by the history, experience and culture of the people - phraseology, which makes the language bright, lively, expressive and makes it possible to Express and convey all the richness of human thoughts and feelings.



## REFERENCES

1. Amosova N. N. *Fundamentals of English phraseology*. - L.: Nauka, 1989.
2. Logan P. Smith *Phraseology of the English language*. - M., 1959.
3. Kunin A.V. *Phraseology of the modern English language*. - M.: International relations, 1996.



## THE CONCEPT OF NATURE AND HEROES IN “ROCKS ALSO CRY”

**Abdurashid Abdurakhmonov**

*PhD student, Fergana State University*

### ABSTRACT

*The article discusses the concept of nature and heroism in the works of Normurad Norkobilov on the basis of the story “Rocks also cry”. The depiction of nature, the mountain, the dog is based on the fact that the character of the protagonist and the state of mind are created through the method of parallelism.*

**KEYWORDS:** *ideological intention, art, method of parallelism, image of a dog, character.*

### INTRODUCTION

The issue of the relationship between man and nature is significant in the work of Normurad Norkobilov. The very name of the author's work attracts the reader's attention. Because, “The first semiotic center in the content is the title, which contains the author's idea, concept. The title is a preface to the first impression, the author and the reader's spiritual dialogue. Assessing the existence, talent, and creative intent of artists begins at this point” [1, 68] stories such as: “Five Continents in the Project”, “The Old Man and the Snakes”, “The Spring”, “The Day of the Eclipse”, “The Land of the Sunless”, “The Day of the Storm”, “The Orphaned Flowers”, novels: “The Lonely Man in the Mountains”, “The Rocks Cry”, “The White Man”, “The Cotton”, “In the Field”, and many others. Given the fact that the title of the work preserves the ideological intentions of the author and the content of the work, these titles, which reflect the natural landscapes, help to draw conclusions about the creative direction of N. Norkobilov. Professor Abdugafur Rasulov, in the foreword to the collection “Day of the Storm”, says that Normurad Norkobilov's happiness as a creator is that the virtue of motherhood and the ability to enjoy the complexities of nature determine the roots of his work [2, 3].

### THE MAIN FINDINGS AND RESULTS

Nature is used by all artists in their work. The peculiarity of Normurad Norkobilov is that he does not simply describe nature. He first perceives it as a living being and elevates it to the level of an image, thereby striving to create the character traits of the

protagonist. It's hard to find a writer's protagonist portrayed in isolation from nature. The author's story “Rocks also cry” describes the organic connection between rock, spring, stone, spruce, bear, dog and man. The protagonist of the work, Ernazar Polvon, is a mountain man with his thoughts and nature. His approach to life and humanity is in harmony with nature, the mountains and the animals in them. This can be seen in the conversation with his grandson Bekkul.

- Your dog's in the mountains, son.

- “What's left?” This time the boy's voice was full of bitterness.

- “It'll come back and play with these creatures”.

At this point, the author portrays his grandfather as a wise old man. The grandfather does not ignore the fact that the grandson has become a friend and companion with the dog (Ziyrak) and loves him. That's why he doesn't suddenly say, “Your dog is dead”. In general, the writer's reference to the image of a dog has a special symbolic meaning. Because in some sources, the dog is a symbol of loyalty, dog is one of the traditional characters in Eastern poetry, serving as an artistic medium that sometimes connects the lover with the lover, and sometimes interferes with the lover's vision. A lover's compliment to a lover's dog is a sign of desire to be close to him. In mystical literature, the dog is glorified as a symbol of fidelity, devotion and devotion [4, 85]. It is no secret that the dog plays an important role in the close relationship between nature and humanity. This intimacy, of course, helps to reveal the character of the child.



Ernazar uses the word "child" in a consolation tone at the end of the wrestler's speech. This word also helps to describe the character of the wrestler in the play. Sensing Bekkul's frustration in advance, the grandfather speaks to him in a soothing tone.

The groaning expected from the grandson's response is felt in the intimacy with the dog. This can be seen in the fact that he speaks in a "heartbreaking" voice. In Uzbeks, grandfather is a respected person. The protagonist of the story, Ernazar Samson, is respected not only by his family, but also by the villagers. Such a person should have enough reason to talk to his grandson. The author uses the friendship of a dog and a child as a basis for this.

No matter how hard it is, the grandfather will be helpless in the face of the friendship between nature and man (Ziyrak and Bekkul). He struggles to tell her granddaughter the real story, unable to find any way to help her, to make up for the friendship that has broken her heart. This text opens with a diamond, a colon, and a load. That is, the pronoun used in the grandfather's sentence "This..." means uncertainty, abstraction, while the plural pause means a pause in the speech process. The pause is a testament to Ernazar's psychophysiological condition, which makes it difficult for him to tell his grandson openly.

The helpless grandfather uses the taboo method [5]. In other words, by saying that a child's dog will return "playing with animals", the tag is the opposite. This is where the child's worldview comes into play. The boy was born and raised in the mountains. He knows that it is impossible to "play field" with a living wolf, and that the result is death.

Grandfather uses emphasis to better explain to Bekkul that Ziyrak is dead. It is clear from the phrase that the dog does not return.

- I shot him, "he said. "If you urinate, I won't hurt you".!

- That's good, said the boy, swallowing the pain of the loss. "It was a good dog".

- The sword of the lowly is always good. In the winter, when the animals came down from the hill, you could see the sword of your dog. It would stand on one side and hit her in the lap. Such a dog cannot be kept alive. It's too hot in here [3, 183].

When he senses the sadness in Bekkul's voice during the conversation, his grandfather's affection is replaced by a sharp look and anger. Ernazar's angry remarks in the story reflect not only the information that the dog was shot, but also Bekkul's dissatisfaction with the wetness of his eyes as a young man.

The wrestler, who has a special love for his sons and grandsons in the family, loves Bekkul more than anyone else. But he can't accept the tears of a dog. The phrase above encourages the grandson to

persevere by telling the young man what he really should be otherwise he might be shot as well.

Whether he is alive or not, he believed in honesty, purity, and courage, which are the basic tenets of life. "He is a straightforward, determined, ultra-national hero who wants the main motto of every person in life to be spiritual purity, who can find the strength to live properly in any situation" [6, 64]

In fact, the story is about Ziyrak, who was afraid to meet a giant bear, and his two dogs, Ernazar, who shot the wrestler. The wrestler has been testing his dogs on the Monkey Bear for five years. At this point, the bear is not shot it serves as a test object for the dogs. A feral dog injured in a collision is given special care. Because it is a purebred, unique dog, the main ideological content of the story is the wrestler's attention to the breed and his efforts to preserve the purity of the offspring.

The protagonist puts the practice of keeping the offspring clean, not only in animals, but also in humans and in their own families. The author gives the protagonist's neglect of the girl with an interesting conversation between the secretary and the wrestler as they receive their birth certificates. He likens the family to a majestic tree. In doing so, he compares himself to a giant tree, his sons to its branches, and his grandchildren to the leaves of those branches. There is no place for girls in this tree, and the grandchildren do not like the girl. Because they are branches of another tree

The wrestler's point of view about the young man is unique: [3, 178]. In the eyes of the wrestler, beauty is not necessary for a boy, but at the same time it loses the main role of a man. At first, Osar, a middle-aged boy, is the only one with a beautiful face. But Ernazar's view is correct. A father cannot accept a son who does not turn around in wrestling, who walks in the city, who drinks alcohol and, most importantly, who commits adultery. He considers it his horn. Throughout the play, Ernazar regrets that Osar is a child and not a dog. He claims that if he had been born a dog, he would have shot the breeder. It's not just a matter of the boy being a rock-solid, unequal wrestler, but of having a strong place in the family. A strong position is defined by honesty, purity, and honor.

The work depicts the struggle and conditions of the mountains. Ernazar Polvan, who lost his honor after two sons fell on the Turkmen wrestler and Osar did not want to fight, enters the ring. The fact that the Turkmen wrestler, who fell out of respect for his honor, age and status, fought again, saying, "Take things in stride, take care of your father ..." shows how important honesty is in a wrestler's faith. When he returned home, his trusted son, Kochar, who was not around, beat the wrestler and said, "You will





knock him down. Ernazar knocked the wrestler to the ground. If you don't break it, I'll divorce your mother," he said, adding that he could not control his anger and shame, and that his pride and dignity were high.

The story "Rocks also cry" depicts the relationship between a mountain, a picture of nature and a wrestler. Importantly, the nature of such heroes as Ernazar Polvon, Kochar Polvon, Turkmen Polvon is expressed in harmony with stones and rocks. Ernazar's notions of wrestling seem simple, plain, even outdated. In fact, the structure of nature, its thousands of years of life, is based on simple, straightforward, extremely profound laws. In the story "Rocks also cry", all human beings are compared to their behavior [7].

Ernazar is offended by the wrestler Osar and tries to guide him to the right path with kind words and advice. The situation did not turn out as the hero wanted. At the end of the story, Osar is killed by rocks moving from a rock. It is noteworthy that the author prevents the wrestler from becoming a child and punishes Osar for committing adultery with stones. In the story, it makes sense once again Osar under the rocks. Because when Ernazar Polvon says, "I wish boy is as rough as a rock", he means an honest, pure, real man. Osar, on the other hand, avoided honest struggle and committed adultery. Describing the victory of justice over injustice and purity over impurity is one of the main tasks of literature.

## CONCLUSION

In short, in the story "Rocks also cry", the inner world and character of the protagonist are described in harmony with the rock. In general, the author uses the method of parallelism to use the image of nature to illuminate the character and psyche of the protagonists. In all the works of the author, the image of nature, animals and people are in harmony, and this is the key to defining the unique style of Normurad Norkobilov.

## REFERENCES

1. Rasulova U. *Structural-semiotic features of modern stories. Uzbek language and literature. 2019, issue 6.*
2. Norqobilov N. "The day of the storm". Tashkent, Sharq Publishing House, 2007.
3. Norqobilov N. "The Lonely Man in the Mountain." Tashkent: "Uzbekistan", 2011.
4. Mingboeva D. "The Magic of Emblems." Tashkent: "New Age Generation", 2007.
5. <http://uz.m.wikipedia>.
6. Rustamova M. *Character in the stories of Normurad Norkobilov. Uzbek language and literature. 2006, issue 3.*
7. Rasulov A. *Two worlds one step. Sharq Yulduz magazine. 2012, №. 2.*



## REFLECTION OF MODERN PROBLEMS IN POETRY (ON THE EXAMPLE OF AMIR KHUDOIBERDI'S WORK)

**Manzura Urakovna Namazova**

*Teacher of "Uzbek Language and Literature" Department of Shahrissabz branch of Tashkent State Pedagogical University*

### ABSTRACT

*In this article, Amir Khudoiberdi's poems are studied as the object of research. The poems contain ideas about modern problems, human vices, and various topics, and the article provides an analysis of them.*

**KEYWORDS:** *problems of the time, contemporary literature, humanity, the flaws of the time, society, Amir Khudoiberdi's poems, gratitude, hypocrisy.*

### INTRODUCTION

The development of human society has never been easy and unhindered. There have always been challenges facing society. These are, on the one hand, various epidemics related to earthquakes, floods, droughts, changes in solar radiation, etc., manifested as a result of natural disasters, and on the other hand, as a result of human activities anthropogenic problems of socio-economic, political and cultural life [7].

Also in the work of Amir Khudoiberdi, philosophical views, understanding of the world, feeling the spirit of today are a priority. The poet's poems such as "Devonalarmiz", "Shukri yo'q kimsa", "G'ofil bo'lma", "Ustozimning menga aytgan so'nggi so'zlari", "Tavallo", "Kecholmasman", "Tabiatning jazosidan qo'rq" more than a hundred poems can be a life guide for the upbringing of young people.

### THE MAIN RESULTS AND FINDINGS

Another characteristic feature of Amir Khudoiberdi's poems is that they are about the pain of the modern world, about humanity and human qualities. Everyone's prestige and role in society increases with good behavior, decreases with bad behavior, and eventually loses its place in society. Our people praise and appreciate such phrases about polite people as humane, highly moral, well-mannered. He is also revered as a possessor of good qualities, humane qualities. That is why the poet presented to the public examples of his work on this topic.

*G'ALAMISGA*

*Fazilatim ko'rmay nuqul nuqsonimni izlaysan,*

*Yaxshiliklar ko'rib tiling qovushmaydi "rahmat" ga.*

*Ichi qora bir badbinsan, yomonlikni gizlaysan,*

*Derlar: "Ari gulga qo'nar, pashsha esa axlatga..."*

(Meaning: "To the spoiler man")

You look for my flaws without seeing my virtues,

When you see good things, you don't say "thank you".

You are a black villain, you hide evil,

They say: "A bee lands on a flower, and a fly lands on garbage ...")

\*\*\*

*Farishtani yo'qla,*

*Shayton ko'rinur.*

*Har mehrob ostida*

*Chayon ko'rinur.*

*Tillardagi bolga*

*Achchiqtosh tutsang,*

*Dillardagi og'u*

*Ayon ko'rinur.*

(Meaning:

Call the angel, and Satan will appear.

Scorpion appears under each altar.

If you touch the hammer on the tongue, the poison in the heart will be clearly visible)

In these verses, the poet writes about the qualities of human beings today, just as much is not seen in humanity, and human behavior is not always as sincere as it seems.

There is another trend in the work of Amir Khudoiberdi, which is reflected in the society over the years, with the passage of time. This theme is love. Love is important for every poet - in his lines he remembers the heartbeat and emotional steps of the reader. In Uzbek poetry, as in other poetry, the



reference to the female figure as a symbol of love is more common. After all, respect for women is one of the highest values of our people. Amir Khudoiberdi is also famous for such poems as "The Tomb of My Love", "The Sleeping Beauty", "You", "One Heart", "Because I Love You", "One Heart", "The Girl Who Forgot Her Love". takes up a sacred theme. Like all of the poet's poetry, love lyrics are unique, characterized by the depth of expression of emotions, the naturalness of emotions, vitality, realism. The pain of unrequited love, the pain, the deep human experiences, the world of pain, sorrow, burning, anguish of the owner of a big heart, who dreams of true love, are the content of the poet's love lyrics. This time, the artist writes only about the love that is betrayed, the love that is declining. He thinks there is no pure love at the moment:

*Ey Tangrim! Qalbimni qutqar, najot ber,  
Muhabbat dorusi og' u bo' lmasin.  
Mening yuragimda ingrayotgan she'r  
Tog'dagi eng so'nggi ohu bo' lmasin.*

*Qalbsizlardan qutqar, sevgisiz kaslar  
Ko' magiga aslo duchor aylama.  
Holim qaydan bilsin oshiq emaslar,  
Xoru zor aylama, nochor aylama.*

*Yuragimni yoqding, samoviy hislar  
Sandonidan tushdi qalbgga parcha cho'g'.*  
*Yorning dudog'ida yig'lar yalpizlar,  
Iforidan bahra ololganim yo'q.*

*Sabr ber, sevgiga begona dunyo  
Poyida xor qilma, bo' lmayin abgor.  
Quzg'unlar oldiga tashlamagin, o,  
Sevgiga limmo-lim qalbimni zinhor!*

*Holimdan kulmasin ishqdan benasib,  
Toshbag'ir izdihom, miskin jon uvol.  
G'ayurlar qo'liga xanjar tutqazib,  
Sabrim sinayapsan balki, ehtimol?!*

*Sevmasa sevmabdi bir qiz, jahonda  
Yo'qmi o'zga suhuv, o'zga zebo qad?  
Sevaman deb so'ngra tonmoq yomon-da,  
Subutsiz onlarga kerak-ku toqat!*

*Yurak sanchib chiqdi, uvushib og'rir,  
Kiprik yumilmadi, ko'zdan qochdi xob.  
Bu kecha yaldoli, kechdi ko'p og'ir,  
Borlig'im qopladi alam, iztirob.*

*Bir bo'sa, birgina lufu, shirin so'z  
Dardlaringga malham bo'lurdi, illo.  
Kafanmi egningga yopinganing bo'z,  
Xazonmi kiyganing sap-sariq hullo?!*

*O'lim va hayotning orasi asli*

*Bir qadam, toysang bas, yo'qlik u yog'i.  
Bir lahza ajalga bo'lsa qalb taslim,  
Bir lahza umringga quyilsa og'u.*

*Tangrim, himoyating kerak shu asno,  
O'zing sev, yorlaqa miskin qulingni.  
Tilarmen, imdodsiz qoldirma aslo,  
De: "Arshdan uzgaysan saylab gulingni!"*

*Degin: "Seni anglab yetgay sevganing,  
Ko'nglingda uyg'ongay samoviy farah".  
Icharmen, sharob yo og'u berganing,  
Tutqazganing esa ilohiy qadah!  
2.11.2019*

(Meaning: O God! Save my heart, save me,  
May love not be poison.

Save me from the heartless, never turn me to  
their help.

No matter how hard they try, they are not in  
love.

There are tears of mint on my lover's lips, I  
haven't been able to enjoy the scent.

A girl who didn't love if she didn't love, Is  
there any other beauty in the world?

It's bad to deny that you love me, but they  
need patience without proof!

My heart pounded, it ached, my lashes didn't  
close, I fell asleep.

Tonight is a nightmare, it's been a hard night,  
My existence is covered with pain and suffering.

A kiss, a single grace, a sweet word would be  
an ointment for your pain.

It is a step between life and death, and if you  
fall, then nothingness begins.

For a moment the soul surrenders to death,  
For a moment it pours into your life.

Lord, you must protect me at this time, Love  
yourself, bless your poor servant. Please don't leave  
me helpless,

Say, "You will be removed from the Throne  
and you will laugh."

Say, "I love you so much that I understand  
you,

Heavenly bliss awakens in your heart.  
I drink wine or poison if you give me,  
What you hold is a divine glass!)

**MEHR BERDIM**

*Mehr berdim, mehr ulashdim,  
Qalbm to'lib kohiy hislarga.  
Etagingga xasdek ilashdim,  
Chopib bording mehrsizlarga.  
Vafo rasmin chizdim qaroqqa,  
Sadoqatim qoldi poyingga.  
Sen-chi o'xshab xudbin xoinga  
Ketding jafo gullagan yoqqa.  
Sen deb qancha kechdim o'zimdan,  
Qadrim sira etmading qadr.  
Ketayapsan, anqib izingdan*



*Chuchmalgina eng arzon atir...*

02.04.2021

(Meaning: "I GAVE MERCY")

I gave mercy, I shared love, My heart is full of feelings.

I clung to your skirt, You ran to the merciless.

I drew a picture of fidelity to a thief, My loyalty remained on your feet.

Like you, you went to a selfish traitor.

No matter how much I missed you, you never appreciated me.

You are leaving as the cheapest perfume ...)

As long as everyone in the community interacts with each other, their lives will only get better if there is kindness and mutual trust between them. Man's dignity is judged by the result of his kindness. No matter how rich or powerful a person is, he will not have any dignity if he does not have kindness [6]. Feelings of compassion and loyalty are closely related. Therefore, in the poem "I gave mercy", the poet says that the reason for giving mercy is loyalty and fidelity, but you have given them up, so a person who does not appreciate mercy, that is, a person without love, is like a cheap perfume.

*TARJIMAI HOL*

*Tarjimai holim*

*Oddiy. Ismim – She'r.*

*Millatim – Ezgulik,*

*Vatanim – Yurak.*

*Yoshim – o'tmish bilan*

*Olis kelajak*

*O'rtasida tugun –*

*Bugun.*

*Kasbim – Sevish, Azoblanish.*

*Maslagim – Toblanish.*

*Orzuim – olamni*

*Oq ko'ylakda ko'rish.*

*Ustozim – Adashish.*

*Shogirdim – Tashvish.*

*Do'stim yo'q,*

*Tanigan dushmanim uchta:*

*Loqaydlik, Soxtalik*

*Hamda Xiyonat.*

*Uyim – Yolg'izlik,*

*Xotanim – Yolg'izlik,*

*Bolalarim – Yolg'izlik.*

*Sig'inganim – Erk,*

*Sog'inganim – Erk!*

*Izlaganim – Haq,*

*Topmaganim – Haq.*

*Boshimni kundaga*

*qo'yib aytganim:*

*"G'aflatdan ko'z och-da,*

*Oyoqqa qalq, Xalq!"*

(Ma'nosi: Autobiography)

My autobiography is simple. My name is a poem.

My nation is goodness, my homeland is heart.

My age is the past and the distant future

The knot in the middle is Today.

My profession is Love, Suffering.

My advice is to warm up.

My dream is to see the world in a white shirt.

My teacher is lost. My student - Anxiety.

I have no friend, I know three enemies:

Indifference, Falsehood and Betrayal.

My home is loneliness, my wife is loneliness, my children are loneliness.

What I miss is freedom, what I miss is freedom!

What I seek is the truth, and what I do not find is the truth.

Putting my head to the sun, I said: "Open your eyes from ignorance,

Get up, people!")

In this biography, the poet writes about his poems, trying to explain the nature of his poems, what is their main idea. After all, as Abdurahmon Primkulov wrote: "The poet's sincere confession, according to the figurative expression," the biography is simple: His name is Poetry. Nationality - Goodness. Homeland - Heart. Age is the distant future with the past. The knot in the middle is today. " His only dream is to "see the world in a white shirt." Remember that the "white shirt" is a symbol of purity, goodness, generosity and justice. Among them, the poet says that the Master is to get lost, the Disciple is Anxiety, and that he is deprived of a true friend. There are three known enemies: Indifference, Falsehood, and Betrayal" [1].

*ZAMONAMIZ*

*Lo'ttibozga zar chopon,*

*Munofiqa tavoze.*

*Quloqqa yoqar chunon*

*Qarg'alarning ovozi!*

*Bulbulmisan, tur nari,*

*Kuyingga yo'q hushimiz.*

*Maynavozlik hunari,*

*Mayna bizning qushimiz!*

*Oqilmisan, go'rga bor,*

*Kirgin qora tuproqqa.*

*Tirik yursang, xorsan, xor,*

*Aylanasan urpoqqa!*

*Shaloqchida bor "shatak",*

*Qaroqchida martaba.*

*"Yelkaga mindi patak,*

*Boshga chiqdi paytava".*

*Johilga izzat-ikrom*

*Zolimga el qarsagi.*

*Qozonasan shaksiz nom*

*To'qiyversang varsaqi.*

*To'g'riga to'qmoq amal,*

*O'g'riga hadsiz imkon.*

*O'marishni bil avval*

*Mansab istasang, nodon!*

*Nonko'rmisan, kel, senga*



*Uyimizning to'ri bor!  
Til burromi yolg'onga,  
Mukofotning zo'ri bor!  
Maddohmisan, unvoning  
Oshirilar birpasda!  
Pufak misoli shoning  
Shishirilar birpasda.  
Halolmisan, bag'al kam,  
Imkon yo'qdir boyirga.  
She'rlari zo'r bo'lsa ham  
Shimildiriq shoirga.*

(Meaning: OUR TIME

The sound of crows is so pleasing to the ear!

If you are a nightingale, stay away, we have no consciousness.

You're smart, go to the grave.

If you walk alive, you are a chorus.

Respect for the ignorant. Applause to the oppressor.

You will win an unquestionable name, if you weave.

Knitting is the right thing to do.

Know the theft first if you want a career.

If your tongue is prone to lying, the Reward is great!

If you are honest, you have no chance to get rich.

Although his poems are great, there is nothing for the poet.)

In the poem "Zamonamiz" Amir Khudoiberdi writes about the current situation and people. The vices of today are that lies and deception abound, and that honest people can never be rich.

*SHUKRI YO'Q KIMSA*

*Shukri yo'q kimsaga cho'zsang qo'lingni  
Yamlab yelkanggacha yutib yuborar.  
U bilan bog'lama zinhor yo'lingni,  
Joningni paxtaday titib yuborar.  
Seni bir chaqaga sotib yuborar.*

*Shukri yo'q kimsaga kelmagil yovuq,  
Uqubat eshigin ochib yuborar.  
Tunlaring yaldoli, kunlaring sovuq,  
Yuzingga bor zahrin sochib yuborar.  
Gul berma, gulingni otib yuborar.*

*Shukri yo'q kimsani ko'rsang yiroqla,  
Ko'ksingni bexanjar tilib yuborar.  
Ista qaytadan tuz, yama, quroqla,  
Umringni parchalab, bo'lib yuborar.  
Ezib, oyoq osti qilib yuborar.*

*Yuzida tolening ifodasi yo'q  
Nafs itin bandidan yechib yuborar.  
Sinovda sabri yo'q, irodasi yo'q.  
Bir lahzada sendan kechib yuborar.  
Kafaning bemavrid bichib yuborar.*

*Shukri yo'q kimsaga yaqin borma, qo'y...*

(Meaning: A person who is ungrateful

If you reach out to someone who is ungrateful, he will lick your hand and swallow it to your shoulder.

Don't tie your way with him, he'll sell you for a penny.

Do not come to anyone who is ungrateful, He will open the door of suffering.

Your nights are cold, your days are cold, Your face is full of poison.

Don't give a flower, it will shoot your flower.

If you see someone who is ungrateful, go away, He will tear your chest in vain.

Don't go near someone who isn't thankful, let him ...)

Gratitude is the power that makes everything better, that fills our lives with light and joy.

So let's start the day by saying thank you? After all, isn't our life happiness in itself?! As long as our body is healthy and our heart is beating, it is possible to solve any problem and find a solution to it. The feeling of gratitude should not only be reflected in our language, but we should feel it from the bottom of our hearts. This is the true meaning of the poet's verses, and this is the idea that the poet put forward in the poem.

Amir Khudoiberdi is a versatile artist. It has its own style. In his poems there is sincerity, sadness, sometimes very happy, sometimes the cries of heroes tired of the blows of life. That is why the audience of the poet's poetry is wide. There are many poems in the works of the poet, which reflect the spirit of today and are dedicated to the problems of society. What we have analyzed so far are just some of them.

The bottom line is that there have always been problems. But the solution to these problems lies in people's attention to each other, says teacher Robiya Sodikova.

## CONCLUSION

"Where there is attention, there is no sleep, no thoughts, no ideas. Where there is focus, loyalty to ourselves, our parents, our family, our profession, our dreams, our state, our people, our rich spiritual heritage, our history, our future, in short, our homeland, is stable. There will be enlightenment. Where there is devotion, enlightenment, there is development, there is progress. So even simple events are caused by negligence, whether it's a simple accident, a simple accident, a simple illness" [5].

## REFERENCES

1. Abdurahmon Primqulov. *Iztriob inkishofi yoxud shoir Amir Xudoyberdi portretiga chizgilar. Ikkinchi nashr/ Iztriob development or draw a portrait of the poet Amir Khudoiberdi. Second edition. – T.: "Musiqqa", 2015.- 78 p.*





2. *Rahimjonov N. Mustaqillik davri o'zbek she'riyati/ Uzbek poetry of the independence period –T.: Fan, - 260 p.*
3. <http://amirxudoyberdi.blogspot.com/>
4. <http://amirxudoyberdi.blogspot.com/2014/04/blog-post.html> *May the river always be your heart/Interviewer Maqsud Hamroyev/22.04.2014.*
5. <https://www.amerikaovozi.com/a/a-36-2007-08-04-voa1-93349049/797581.html>
6. <https://sammuslim.uz/oz/articles/eductaion/mehr-oqibat-inson-hayotining-ziynatidir> *E.Abduvoxidov - Speech of the Imam Khatib of the mosque "Qiyqim" of Koshrabad district*
7. <https://hozir.org/hozirgi-davrning-global-muammolari.html>
8. <https://review.uz/uz/post/ozbekiston-yoshlari-muammo-va-istiqbollar>



# AN IMPORTANT SOURCE ON THE HISTORY OF AMIR TEMUR

<sup>1</sup>Zubayda Khamidovna Yuldosheva, <sup>2</sup>Jumaeva Shohida

<sup>1</sup>Lecturer, Department of Civil Society, Termez State University

<sup>2</sup>Lecturer, Department of Civil Society, Termez State University

## ABSTRACT

*This article discusses important sources on the history of Amir Temur. The chronological boundary of the source covers the period from the birth of Amir Temur to 850 years. The author comments on this: "Thus, all the lands of Ajam up to the borders of Movarounnahr, Khorasan, Khorezm, Jurjan, Ajami Iraq, Mozandaran, Kandahar, India, Kerman and Azerbaijan to this day, that is, until 850 (1436-1437) Shahrukh.*

**KEYWORDS:** *Movarounnahr, Khorasan, Khorezm, Jurjan, Ajami Iraq, Mozandaran, Kandahar, India, Kerman, Azerbaijan, Mawlana Ahmad al-Tirmidhi, Mawlana Mansur al-Qaghani, Ibn Bandgir, Abdul Qadir, Tojuddin al-Salmani.*

## INTRODUCTION

The role of primary written sources in the study of the history of Central Asia in the XIV-XV centuries is invaluable. Among such primary sources is the source of "Shahaybuddin Ahmad ibn Muhammad ibn Abdullah ibn Ibrahim" "Wonderful history of Taymur"[1.141]. The author has turned into a book the impressions he saw and heard throughout his life, based on the stories of his contemporaries. Ibn Arabshah wrote about it: "I remembered what I saw in this story, I remembered what I narrated from others about it, and I wanted to narrate what I narrated from others about it, because it was one of the great events, the mother of exemplary events, and so on. destiny does not agree with what characterizes him so much" [2.67]. Although the source is devoted to the life of Amir Temur and partly to the history of the Timurid period, the pages of the work mention the names of many historical figures who lived before that period and during this period. Ibn Arabshah said in the preface of the source: "I ask God to give me the truth and to inspire me to fight in the way of truth. Of course, it is God Himself who delivers the wish and who unintentionally directs the arrow at the target. (On this path) God is "a faithful and excellent guide to me"[2.68] - However, Amir Temur was reluctant to cover some historical events related to the life of Amir Temur[1.142]. Nevertheless, a certain part of the information given in this source is of great historical importance.

## THE MAIN FINDINGS AND RESULTS

U. Uvatov, who translated the source into Uzbek, suggested that the work be divided into four sections according to its content and explained it as follows: Ajoyib al-Maqdur, which covers the events of almost half a century, consists of a large number of dhikrs, and the author has tried to bring them up gradually according to the course of events. Based on the location of these "dhikrs" and the composition of the work, in our opinion, it is expedient to divide it into four sections. The first section provides information about Timur's genealogy, early childhood and adolescence. The second section deals with the military campaigns of Temur in Movarounnahr from the time of his independent seizure of power (1370) to the end of his life. The events after Timur's death (1405) until about 1436 are described in the third chapter. The last fourth section contains information about the natural qualities of Timur's qualities and forms"[2.37]. In our opinion, the historical information given in the fourth section of the source is distinguished by its originality and attractiveness. The chronological boundary of the source covers the period from the birth of Amir Temur to 850 years. The author comments on this: "Thus, all the lands of Ajam up to the borders of Movarounnahr, Khorasan, Khorezm, Jurjan, Ajami Iraq, Mozandaran, Kandahar, India, Kerman and Azerbaijan to this day, that is, until 850 (1436-1437) Shahrukh. was"[2.64]. Ibn Arabshah in



the last chapters of the source “On the virtuous qualities of Timur and the innate qualities and nature given to him”[2.65-69], “Temur’s attitude to scientists and religious scholars” [2.69-70], “Timur’s sphere of thinking and the establishment of espionage in the state”[2.71-72], “Examples from the stories of Timur’s perception”[2.72-79], “Temur’s relations with his subordinate rulers and his hunting process”[2.79-81], “On the mineral resources brought to the state of Timur”, “On the gardens and orchards built in the state of Timur and the settlements built around Samarkand”[2.82-83], “About Temurid princesses” [2.83] wrote down valuable information. Ibn Arabshah also gave some important information about the children and grandchildren of Amir Temur in the source. In particular, the author provides the following information about the grandchildren of the owner: “Most of Timur’s grandchildren, except for Shahrukh’s children, are in crisis. The most prominent of his grandchildren were Ulugbek, the governor of Samarkand, Ibrahim Sultan, the governor of Sheroz, and Boysunqur, the governor of Kerman. They both died in 838 (1434-1435), and Juqi, who had marched against Alexander, the son of Joseph the Black, and after the death of the Black, crushed him (Alexander). These events took place in the months of 839 (July 1435-June 1436), and he himself died at the end of that year.” [2.84] Ibn Arabshah, in his source “Ajoyib al-Maqdur”, said the following about the scholars who lived and worked in Samarkand: If the precious creations of the alphas were adorned with the jewels of the attributes of those nobles, the world would (already) be filled with the most unique stones and pure gold bars. These are the people I know and whose names I remember. But there are innumerable people whom I do not know, or whose names I do not remember, and who are beyond my reckoning. In short, Timur gathered every (useful) soul and brought everything to Samarkand. As a result, in Samarkand there was a gathering of scholars from all walks of life, who excelled their peers and became a symbol of virtue in the face of every outstanding scientist and unique style of art” [2.87]. The author of the source is Mawlana Abdumalik, Nu'monuddin Khorezmi, Khoja Abdulavval, Isomuddin ibn Abdulmalik, Mawlana Sa'duddin at-Taftazani, Sayyid Sharif Muhammad Jurjani, Sheikh Shamsuddin Muhammad ibn al-Jazari, Mawlana Fakhruddin, Abdullatif ad-Domgani, Mawlana Asaduddin, Sharif Hafiz Husseini, Mahmud Muhriq al-Khwarizmi and Jamaluddin Ahmad al-Khwarizmi, teachers of music, Abdulkadir al-Maraghi, Ahmad ibn Shams ul-Aimma, Mawlana Ahmad al-Tirmidhi, Mawlana Mansur al-Qaghani, Ibn Bandgir, Abdul Qadir, Tojuddin al-Salmani, Mawlana Ahmad from the astrologers, al-Haj Ali Ali Shirazi from the jewelers, al-Haj Muhammad Muhammad Hafiz Shirazi, Altan from the

stonemasons, Muhammad ibn Aqil from the chess players al-Khaymi, Zayn al-Yazdi, Alouddin at-Tabrizi, singers Abdulkadir al-Maraghi and his son Safiuddin, son-in-law Nasriin, Qutb al-Mousili, Ardasher al-Changi, painters Abdulhay al-Baghdadi, gardeners Shihabuddin Ahmad az-Zardakshi reached.

## CONCLUSION

In short, Ibn Arabshah’s source “Ajoyib al-maqdur fi tarixi Taymur” is important in studying the history of the political, socio-economic and cultural spheres of Central Asia, Iran, the Caucasus and other countries of the East in the second half of the fourteenth century and the first half of the fifteenth century. The study and comparison of other primary sources created at that time in the scientific analysis and circulation of the information given in the source further expands the scope of research.

## REFERENCES

1. B.A. Ahmedov. *Sources of history of Uzbekistan*. Tashkent., 2001. – P. 141,142.
2. Ibn Arabshoh. *Miracles of Destiny in the History of Timur / Translated from Arabic. and comments, preface U. Prepared by Uvatov; K.I.-Tashkent: Labor, 1991. – P. 37-87.*
3. BAKIEV, A. (2007). *Comparative Analysis of Timurids Genealogy in Historiography. Ölümlünün 600. yılında emir Timur ve mirası: uluslararası sempozyumu*, 165.



## SLANG AN INDEPENDENT PHENOMENON IN THE SYSTEM OF SOCIAL DIALECTS

Maya Erkinovna Tursunova

Lecturer, Department of Russian philology, Fergana State University

### ABSTRACT

*In the article the description of slang as one of social dialects is given, various social dialects are considered from the point of view of their similarities and differences from slang, the concepts of slang and jargon are differentiated.*

**KEY WORDS AND PHRASES:** *social dialect; slang; jargon; argot; cant; colloquialisms; vulgarisms.*

### INTRODUCTION

The concept of slang causes a lot of controversy among linguists. Famed slang scholar Eric Partridge believes that many scholars use the word "slang" as a synonym for jargon, argo, or kenta. The author of the slang dictionary R. Spears notes that the term "slang" was originally used to denote the British criminal jargon and was synonymous with the word "kant". Over the years, the meaning of the concept of "slang" has expanded, and it includes various types of non-literary vocabulary, such as jargon, vernacular, dialects and vulgar words [Orlova]. Attempts have been repeatedly made and are still being made to distinguish between these terms. As noted by IR Galperin, the term "kent" is used to designate the conventional language of individual professional and social groups. Some lexicologists suggest keeping the term "jargon" to denote specific professional and technical concepts.

### MAIN PART

It is very difficult to draw a clear line between these layers of vocabulary, because, as I.R. Halperin points out, "the difference between professionalism and jargon, between vernacular and dialectic is generally difficult to account for" [The Great English-Russian Dictionary, p. fifteen]. From the point of view of use in speech, jargon and professional slang are characterized by a much narrower sphere of use than for general slang and dialectisms. Jargon and professionalism, as a rule, are understandable only to certain narrow groups of the population. Both of these groups can be attributed to little-known slang, which is often referred to as argo. General slang is a completely different matter. I.R.

Galperin refers slang, professionalism, jargon, vulgarity and dialectism to non-literary colloquial vocabulary. Consider the concept of slang in relation to all other classes.

### JARGON AND SLENG

For English-speaking linguistics, the distinction between the concepts of "jargon" and "slang" is characteristic. In English linguistics, it is customary to use the term "slang" to denote an uncodified language, ie. territorial dialects, vernacular, jargon. Researcher IV Pellikh notes that in modern interpretations of the term "slang" can be divided into two subgroups: the special speech of subgroups or subcultures of society and the vocabulary of widespread use for informal communication [Pellich, p. 2]. In domestic linguistics, many researchers (L.I. Antrushina, I.V. Arnold, S.A. Kuznetsova) do not differentiate jargon and slang as two different phenomena in language, interpreting them as speech of a socially and professionally determined group, as well as an element of speech that does not coincide with the norm of the literary language [Antrushina, p. 55-65; Kuznetsova, s. 3]. Thus, slang is opposed to the literary norm [Arnold, p. 162-163]. IR Galperin, on the contrary, distinguishes between these concepts and notes that jargon can become slang, passing from a certain circle to the common one [Galperin, p. 104-116]. Jargon is a semi-open lexico-phraseological subsystem used by a particular social group in order to isolate itself from the rest of the linguistic community. Jargon is, as a rule, emotionally evaluative expressive formations, among which negative lowering nominations prevail, therefore the term itself is usually perceived as a sign of negative



evaluative coloring. A distinctive feature of slang is its secondary education in comparison with jargon, since it draws its material primarily from social-group and social-professional jargons. But in addition to jargon, slang includes individual vernaculars, vulgar words. However, with such borrowing, a metaphorical rethinking and expansion of the meaning of the borrowed units occurs. Slang words are characterized by increased expression, language play, fashionable neology. There is no clear line between jargon and slang for a number of reasons. Firstly, because slang draws its speech material, first of all, from social-group and social-professional jargons. Secondly, slang is also characterized by some social limitations, but much broader, it covers large groups of people, not limited to one social or professional group.

### ARGO AND SLANG

Argo is a special language of a certain limited professional or social group, consisting of arbitrarily selected modified elements of one or several natural languages [Linguistic Encyclopedic Dictionary], it is a closed lexical subsystem of special nominations serving narrow social group interests, most often professional. Argotisms are usually devoid of bright evaluative coloring, which distinguishes them from slang, although they can also be expressive nominations. Often, argotisms are used to hide the subject of communication, so sometimes the content of argotism can be understandable to the uninitiated. Jargon and slangism almost always have a semantic parallel in the literary language, while argotism may not have one. Another difference is that slang does not contain rational nominations - terminoids known only to a narrow circle of dialect speakers.

### SLANG AND KANT

If we follow the opinion of IR Galperin and define Kent as a conventional language of some social and professional groups [Galperin, p. 95], kent and argo act as synonyms. However, kant as a linguistic term in most cases is found in the combination thieves 'cant, which undoubtedly affected the semantics of the word, and many researchers define it precisely as thieves' jargon or the language of declassified elements. Compared to professional argotic systems, the "thieves' language" has a broader and less definite character and covers the most diverse aspects of everyday life and social life, from a peculiar point of view of people outside of civil society and the law. Therefore, the vocabulary of the thieves' argo is much more extensive than in other social-group sublanguages. Unlike argot, jargon and kenta, slang does not have a distinct social group orientation; it is used by representatives of different professions, different

social and educational status and different ages. For example, unlike to game (to lie, slang) known to a large number of English speakers and widely used by the educated population, a beef (a complaint or disagreement within the organization, kent, the language of the mafia), a convict (zebra, circus argo), to troll (to utter a posting designed to attract predictable responses or flames, the jargon of Internet blog users) is used by representatives of certain social groups, while to troll is understandable to wider layers of society, but is used only in relation to Internet use, a convict and a beef in the indicated meanings in general may not be understood by the uninitiated.

### SLANG AND COLLOQUIALISMS

According to S. Flexner, the difference between slang and colloquialisms should be seen in the frequency of use of the corresponding units and in the degree of their comprehensibility. The second difference is the scope of use. Colloquialisms have a wider scope than special slang, but they are much more difficult to distinguish from general slang. There is also a difference in the emotional coloring of slang and colloquialisms. Slang is characterized by a more intense emotional connotation [Wentworth and Flexner, p. viii]. Common between slang and colloquialisms is the informal situation of their use. As an example, we can compare the use of two synonyms for the word "TV" - custard & jelly (slang) and telly (colloquialism).

### SLANG AND PROFESSIONALISM

Professionalisms are words and expressions characteristic of the speech of representatives of a particular profession or field of activity, usually acting as vernacular, emotionally colored equivalents of terms [Linguistic Encyclopedic Dictionary]. Professionalisms, in contrast to their commonly used equivalents, serve to differentiate related concepts used in a certain type of human activity. Thanks to this, professional vocabulary is indispensable for concise and accurate expression of thoughts in special texts intended for a trained reader. However, the informative value of narrow professional names is lost if a layman encounters them. Professionalisms are notable for their emotional expressiveness, but they quickly become outdated. Professionalisms can penetrate the general literary language in the event of a loss of their stylistic marking. Professionalism is a narrower concept than slang, it is used to name objects or concepts that belong to a certain field of activity and are often unknown to people who are not associated with this activity, for example, Irish mail means a bag of potatoes in the speech of English sailors.





## SLANG AND VULGARISMS

Vulgarisms are “rude words, usually not used by educated people in society, a special lexicon used by people of lower social status” [Dictionary of linguistic terms, p. 301]. OV Ignatova classifies vulgarisms as slang, considering them to be a kind of slang. She writes that slang can be divided into two groups:

- Slang words and expressions widely used in colloquial speech.

- Vulgarisms, or swear words [Ignatov].

L. Bloomfield proposed to distinguish between obscene and obscene forms among vulgarisms. Inappropriate language forms are only pronounced under certain limited circumstances: a speaker who violates these restrictions will be ashamed or punished. Obscene forms most often belong to certain spheres of meaning, and often in parallel with them there are forms with the same direct meaning, but without a shade of obscenity (whore and prostitute). Obscene are those forms that are associated with biological needs and procreation. A strict taboo is imposed on them in the language [Bloomfield, p. 161]. Thus, both slang and vulgarisms often have analogs in literary speech, and the difference between vulgarisms and slang is that slang can be used by people of different strata of the population, including educated people, slang units can be found not only in oral communication, but also in fiction and in the media, while the use of vulgarisms is limited by social norms.

From all of the above, it follows that slang is an open subsystem of non-normative lexico-phraseological units of the colloquial language, it serves to express heightened expression and a special, as a rule, negative evaluative coloration. Slang is a suprasocial "general" jargon, or interjargon, in the words of BA Serebrennikov [Serebrennikov, p. 494], ie a set of popular, but substandard words and expressions, replenished, inter alia, at the expense of other social dialects, which is a supra-dialectal integral phenomenon.

## CONCLUSION

Slang is a broader lexical system than jargon, argot, kent, professionalisms and vulgarisms; it is used by wider layers of the population, not limited by the framework of one social or professional group. The delimitation of slang from other social dialects is difficult due to the constant replenishment of the composition of slang units from other colloquial lexical subsystems.

## REFERENCES

1. *Игнатова О. В. Передача сленга в переводе романа Дж. Д. Сэлинджера «Над пропастью во ржи» [Электронный ресурс] // Самиздат [журнал]. Омск*

URL:[http://zhurnal.lib.ru/i/ignatowa\\_o/peredachaslengawperewoderomanaselindzhera.shtml](http://zhurnal.lib.ru/i/ignatowa_o/peredachaslengawperewoderomanaselindzhera.shtml)

2. *Орлова Н. О. Сленг vs жаргон: проблема дефиниции // Ярославский педагогический вестник. 2004.*
3. *Пеллих И. В. Молодежный сленг как социальная разновидность речи // Вестник Адыгейского государственного университета. 2008. Вып. 1.*



# COMPARISON OF CHILDREN'S INTELLECTUAL DEVELOPMENT WHO LIVE IN RURAL AND URBAN AREAS

**Nilufar Sherkuzi kizi Yuldasheva**

*Pedagogy-psychological faculty, Fergana State University*

## ABSTRACT

*The purpose of this research is analyzing intellectual development of nuclear families' 4-5 year old children in rural and urban areas. Precisely, how the child's living environment influence on intellectual development is examined in this article. According to our research, intellectual development of nuclear families children in urban area who are brought up in preschools have a higher result than nuclear families' children result in rural area. The study was conducted in the rural and urban areas of Uzbekistan. In terms of research general result, social environment and living condition can impact on the intellectual development of the children.*

**KEY WORDS:** *Cognitive development, urban and rural areas, thinking, intelligence, extended family, nuclear family*

## 1. INTRODUCTION

Social environment play an important role in the child development. Particularly, parents are essential in terms of child welfare. Because, the child does not automatically adapt to the environment or environmental knowledge is not collected at once. He begins to study the world he is living as a explorer. This activity is inherent in nature. The role of the social world in the cognitive development of the child is important. It is only for its benefit that the child engages in active communication with the people around him in enriching existing schemes. Thus, the role of the family, which is indispensable in every aspect of human perfection, is unmatched. Due to family's attention, support and influence of the family members, the cognitive development of the child raise systematically in every respect. To progress child have to step on every stage of cognitive development but social inputs continuously influence on his development. By these influences child's cognitive processes form and occur new information. So, human cognition, especially child's cognition is one of the most interesting topics in the developmental psychology. How can new knowledge happen in the brain of child? How does he learn them? And how do mental processes occur in his brain? These kinds of questions are central topic of developmental psychology. What is cognition? **Cognition**—a term psychologists use to refer to the activity of knowing and the mental processes by

which human beings acquire and use knowledge to solve problems. The cognitive processes that help us to understand and to adapt to the environment include such activities as attending, perceiving, learning, thinking, and remembering—in short, the unobservable events and undertakings that characterize the human mind (Bjorklund, 2005). The study of **cognitive development** is the changes that occur in children's mental abilities over the course of their lives is one of the most diverse and exciting topics in all of the developmental sciences. The contribution of J. Piaget is unremarkable in the learning of cognitive development. He divided child development into four developmental stages. According to Piaget, cognition develops through the refinement and transformation of mental structures, or **schemes** (Piaget & Inhelder, 1969). Schemes are unobservable mental systems that underlie intelligence. A scheme is a pattern of thought or action and is most simply viewed as some enduring knowledge base by which children interpret their world. Schemes, in effect, are representations of reality. Children know their world through their schemes. Schemes are the means by which children interpret and organize experience. For Piaget, cognitive development is the development of schemes, or structures. Children enter the world with some reflexes by which they interpret their surroundings, and what underlies these reflexes are schemes (D. Shaffer and K. Kipp, 2010). However, the world around child influence in the first turn.



Because of constant contact with the social environment, the child has the opportunity to learn new knowledge with the help of the surrounding people. The child can not find the right solution to all the problems and further broadens his or her knowledge through the constant conversations, guidelines and actions of adults. At the same time, family is the main institution in the social life that the child becomes active. We aimed to explore the child's cognitive development and the peculiarities of the process of learning, depending on the type of place they are living. That is, some of the guides in the process of learning the children of nuclear families living in urban and rural areas are seen. On the other hand, their intellectual growth is tawafulately. Because the environment in which they live does not affect their development. We have experimented to make sure that there are differences in the intellectual development of 4-5 year-olds living in urban and rural nuclear environments.

No one is born of knowledge and we are learning through our new experiences in social life. Sometimes, when certain information is taught by adults, we sometimes enrich our schemes through our active and passive observations. As a result of the social environment, our knowledge grows. The living environment also has a strong impact on development. The purpose of this article is to examine the intellect of a child being raised in rural and urban nuclear families and to distinguish between them.

## LITERATURE REVIEW

Piaget saw children as active agents in their own development, always constructing knowledge and changing their cognitive structures to better understand the world (D. Shaffer and K. Kipp, 20110). The family is generally regarded as a major social institution and a locus of much of a person's social activity. It is a social unit created by blood, marriage, or adoption, and can be described as nuclear (parents and children) or extended (encompassing other relatives) (Nam, 2004)<sup>1</sup>. Thanks to the help and attention of family members, the formation of a child's speech, thinking, memorization, and similar cognitive compositions becomes accelerated. The child's cognitive development does not come automatically. Knowing the child also develops by observing the experiences, tips, and actions of people around him. So people living in the countryside and in the city are different from each other. In addition, there are differences in the development of children in nuclear and multicultural families. In many nuclear families, both

parents have to work together to provide the family with economic support. As a result, the mother is returning to her place of employment by reaching her child to 2 year old. The child remains with a special caregiver or goes to a preschool educational institution. From early morning, parents can not afford enough time for their child to cover family expenditure. That's why the parents of the nuclear family are giving their children nursery in the event that their parents consider the full range of children. Because of the rapid development of the city, it also causes early childhood development. Colorful life in the city provides information that is vital to the development of the child. Life in rural areas in rural areas differs significantly from urban life.

Rural life is a lot simpler and simple, and does not require high intelligence to live there. The child living in such an environment is less likely to face obstacles and new experiences on a daily basis. In the city, the stream of people is also high, and the school has a large school to increase social knowledge. The large number of surveillance objects around it leads to an increase in circuits.

People are *cognitive* beings—active information processors—who, unlike animals, think about the relationships between their behavior and its consequences. They are often more affected by what they *believe* will happen than by what they actually experience (katherin kipdan snoka quyish kk). Bandura emphasizes **observational learning** as a central developmental process. Observational learning is simply learning that results from observing the behavior of other people. Observational learning could not occur unless cognitive processes were at work. We must *attend* carefully to a model's behavior, actively digest, or *encode*, what we observe, and then *store* this information in memory (as an image or a verbal label) in order to imitate what we have observed.

In order to prove ideas above, we had conducted research to analyze intellectual development d kids and we wanted to learn how environment impact on intelligence.

### 1. Method

#### 2. 2.1 Participant

Research was conducted Fergana region's both urban and rural areas of Uzbekistan. 180 4-5 aged children's intellect was tested over experiment. 90 of them were chosen from medium-income family randomly in rural region and 90 of them were chosen in urban area's nuclear families in order to contrast their intellectual development. All children have not any kind of mental and physical illness. Children who were selected to research were from medium-income families.

<sup>1</sup> Nam C.B. (2004). *The Concept of the Family: Demographic and Genealogical Perspectives. Sociation Today (online)*, 2, 2004.



## 2.2 Material and procedure

To check general intelligence we used Raven's progressive matrices (figure 1) A, B,C versions. Children were given one minute for every task. However during the experiment they spent less time than given. We trained with each child in a peaceful room allocated for the psychologist. To check the child's general intelligence, Raven's progressive matrices test A B C were selected and informed on how to do children. During the assignment, it was explained that they should not change their role when placing the icons, and it was set 2 minutes for the assignment. It took 5 minute for the child to rest from one method to another. A psychologist has been helping the child with additional difficulties in teaching methods. For, the child needed additional assistance to understand and fulfill the tasks. Each methodology was systematically explained to the child.

## 3. RESULT AND DISCUSSION

From our research result it can be clear that intellect of nuclear families' children in urban area result was higher than children of nuclear families in rural. The difference between general intellect indicators is statistically significant at 95% confidence level,  $T=3.97$ ;  $P<0.05$ .

Every living thing does not matter where it lives, but its environment. there are differences between the rural and urban life itself, which are evident in the development of people. For example, life in the city is much more colorful than in the habitat, but the lifestyle is complex, requiring a quick decision-making, a solution to the issue, and adaptability. Based on the results of the experiment, the intellectual level of children living in the city showed a higher result. When we studied the lifestyle and the living conditions of children in rural and urban areas, we got a lot of information.

- Most children do not attend to preschools in village as much as cities
- Teachers are not well-educated in village preschool
- Preschools can not respond to standards to teach kids and they are not well-organized
- Parents do not have enough time to train with their children
- Children in urban area learn two or three language from early age and it help to improve cognitive development
- There is no children playground to play, exactly there is no adequate attention to kids' development
- Village life is not complex compare with cities, children may encounter different complex problems

- Village life is not full of social environment it is structured simply

The difference in intellect levels in rural areas was not high, and the difference was not significant. However, it is important to pay attention to the child's intellect. In the city, parents spend additional lessons in mentoring their children.

In the village, children do not have enough resources for their mental and social development because they are at home. Rural children should be able to create a sufficient environment for their intellectual development.

## REFERENCES

1. Barr RG, Konner M, Bakeman R, Adamson L. (2008) *Crying in! Kung san infants: A test of the cultural specificity hypothesis. Developmental Medicine and Child Neurology* 33, 601–10.
2. Belsky J, Fish M, Isabella R. (1991) *Continuity and discontinuity in infant negative and positive emotionality: Family antecedents and attachment consequences. Developmental Psychology* 27, 421–31.
3. Chapple S. (2009) *Child Well-being and Sole Family Structure in the OECD: An Analysis. OECD Social, Employment and Migration Working Papers No. 86. Paris: Organization for Economic Co-operation and Development.*
4. Dunn J, Fergusson E, Maughan B. (2006) *Grandparents, grandchildren, and family change in contemporary Britain. In: Clarke-Stewart and Dunn J (eds), Families Count. Cambridge: Cambridge University Press, pp. 299–318*
5. Dunn J and Stocker CM. (1989) *The significance of differences in siblings' experiences within the family. In: Kreppner K and Lerner R (eds), Family Systems and Life-span Development. Hillsdale, NJ: Erlbaum, pp. 289–301.*
6. Duncan GJ and Brooks-Gunn J (eds). (1997) *Consequences of Growing Up Poor. New York: Russell Sage.*
7. Gass K, Jenkins J, Dunn J. (2007) *Are sibling relationships protective? A longitudinal study. Journal of Child Psychology and Psychiatry* 48, 167–75.
8. Maccoby EE and Martin JA. (1983) *Socialization in the context of the family: parent-child interaction. In: Mussen P and Hetherington EM (eds), Handbook of Child Psychology, Vol. IV: Socialization, Personality, and Social Development, 4th edn. New York: Wiley, pp. 1–101.*
9. Masten AS and Shaffer A. (2006) *How families matter in child development: reflections from research on risk and resilience. In: Clarke-Stewart A and Dunn J (eds), Families Count. Cambridge: Cambridge University Press, pp 5–25.*
10. Nam C.B. ( 2004). *The Concept of the Family: Demographic and Genealogical Perspectives. Sociation Today (online), 2, 2004.*



11. Rodgers B and Pryor J. (1998) *Divorce and Separation: the Outcomes for Children*. York: Joseph Rowntree Foundation.
12. R. Shaffer and K. Kipp. *Development psychology Childhood and Adolescence, eight edition*. – USA, Belmont: Wadsworth, 2010.
13. Rutter M and Maughan B. (2002) *School effectiveness findings 1979-2002*. *Journal of School Psychology* **40**, 451–75.
14. Stocker CM. (1994) *Children's perceptions of relationships with siblings, friends, and mothers: Compensatory processes and links with adjustment*. *Journal of Child Psychology and Psychiatry* **35**, 1447–59.
15. Teti DM and Ablard KE. (1989) *Security of attachment and infant-sibling relationships: A laboratory study*. *Child Development* **60**, 1519–28.
16. Sroufe LA. (2005) *Attachment and development: A prospective, longitudinal study from birth to adulthood*. *Attachment and Human Development* **7**, 349–67.
17. W. Huitt and J. Hummel. *Cognitive Development*, Retrieved, – USA, Belmont: The World Wide, 2002, 234p.
18. <https://www.livwstrong.com>
19. <https://study.com >academy<what is perception>





# AUDIT COMMITTEE CHARACTERISTICS AND AUDIT REPORT LAG IN NIGERIA INSURANCE COMPANIES

**Ovbiebo, E.O.**

*Ph.D. Student, Department of Accounting, Faculty of Management Sciences, University of Benin, Benin City*

---

## ABSTRACT

*This study examines the nexus between audit committee characteristics and audit report lag among Nigeria insurance companies. The study utilises panel data of five (5) listed Insurance companies obtained from their respective annual reports covering the period 2016-2020. Results of the Panel Least Square (PLS) regression estimation technique shows that audit committee financial expertise (ACF) has a significant negative relationship with audit report lag (ARL), while audit committee independence (ACI), audit committee size (ACS) and audit committee effectiveness (ACE), on the average has insignificant positive relationships with audit report lag (ARL) in the insurance sub-sector of the Nigerian economy respectively. On the basis of this finding, companies are advised to include board members who have in-depth knowledge of accounting and finance on their audit committee make-up, as this could assist in reducing the delay in the review of audited financial reports, hence ensure quick presentation of the audited financial information to users.*

---

## 1.0 INTRODUCTION

Audit committee inclusion in the corporate governance mechanism of organisations in the private sectors of the Nigerian economy is statutorily provided for in the relevant sections of the Companies and Allied Matters Act (CAMA) 2020 as amended to date, which is the omnibus law guiding the operations of the corporate activities in Nigeria. The timely delivery or delay in the presentation of the audit report could have a ripple effect on decision making by users of audited financial statements. It is pertinent to state that where there is delay in presentation of audit report, the value relevance of such audited report may begin to nose-dive. According to Aljaaidi, Bagulaidah, Ismail, and Fadzil (2015) audit report lag are often called auditors' signature or audit delay. Habib and Bhuiyan (2011) opined that an understanding of the factors affecting the audit report lag will likely provide an understanding of the efficiency of time in audit assignments.

Al-Ajmi (2008) defines auditors' signature lag, as the number of days starting from the closing date of the company's book until the auditor's signature date in the audit report after the auditor makes an opinion regarding the company's financial statements. This lag in the reporting process could be driven by different

factors. Being that the audit committee has a role to play in terms of exercising its reviewing functions over the work of an auditor, causal empiricism could be suggestive of the fact that audit committee attributes and characteristics could have effect on the audit report lag. It is against this background that this study wishes to empirically examine the nexus between audit committee characteristics and audit report lag in Nigeria.

There are numerous empirical studies in academic literature on the nexus between audit committee characteristics and audit report lag both within and outside Nigeria. Some of these studies includes Ghafran and Yasmin (2017); Emeh and Ebimobowei (2013); Ilaboya and Iyafekhe (2014); and Aljaaidi, Bagulaidah, Ismail, and Fadzil (2015). Most worrisome is that most of these studies have failed to examine the effect of audit committee characteristics on audit report lag in the insurance sub-sector of the economy in the respective climes where they conducted such studies. This constitutes a fundamental gap which serves as a sufficient motivation for this study. Consequently, the objective of this study is to examine the relationship between audit committee



characteristics and audit report lag in Nigeria Insurance sector.

## 2.0 LITERATURE REVIEW

### Audit Report Lag

According to Dibia and Onwuchekwa (2013) audit report lag is defined as the number of days from the accounting year end of a company and the audit report date. They noted that inordinate audit lag jeopardises the quality of financial reporting by not providing timely information to investors and prospective investors. Audit report lag is the number of days from the accounting year end of a company and the audit report date (Dibia & Onwuchekwa, 2013).

Audit report lag has been featuring in academic literature for over four decades. Notable amongst the earliest studies are Beaver (1968), and Courtis (1976). Audited annual report is the most comprehensive document available to the public and is therefore the main disclosure vehicle. Audit delays are increasing function of extent of audit work; decreasing function of incentives to provide a timely report, and increasing function of the extent to which an auditor employs a structured audit approach.

Audit report lag can make investors to lose confidence in the report presented and compound the agency problem. Bamber, Bamber, and Schoderbek (1993) noted that different factors could be responsible for audit delay: either first is the length of time taken by the client organization to close its books and prepare its draft un-audited financial statements ready for the external audit, or the length of time taken by the external auditors to carry out an audit and to complete their investigation of the draft un-audited financial statements before issuing their opinion in the form of an auditor's report addressed to the shareholders of the client organization.

### Audit committee characteristics

The features and peculiarities that are associated with audit committee are regarded as the characteristics of the audit committee. These characteristics includes composition, audit committee financial expertise, audit committee size, audit committee effectiveness (frequency of meetings), and audit committee independence. Others include audit committee gender diversity, audit committee religiosity, and audit committee financial literacy. Audit committee is saddled with the responsibility of reviewing the work of the external auditor and the committee is a corporate governance committee which is usually constituted by the board of directors.

## 3.0 REVIEW OF EMPIRICAL LITERATURE

### Audit committee financial expertise and audit report lag

Baatwah, Salleh, and Stewart (2019) examined the effect of audit committee chair accounting expertise on audit report timeliness, as well as checking the moderating effect of the audit committee chair characteristics. The explanatory variables of the study include Audit Committee (AC) chair expertise, shareholding, tenure and multiple directorships, while audit report timeliness is the explained variable. Given a sample size of six hundred and seventy six (676) Malaysian companies covering the period 2005-2011, data estimation was done with the aid of the fixed effects panel data method regression. The result of the estimation revealed that AC chair with accounting expertise is associated with a reduction in audit delay, while the reduction is more pronounced when the chair holds shares in the company, but is weakened by longer tenure and multiple directorships. Similarly, the estimation also revealed that AC chair with accounting expertise can enhance the timeliness of audit reports even when the quality of financial reporting is lower. This is further supported by the findings that AC chairs with accounting expertise and AC chairs with accounting expertise and shareholding are significantly associated with shorter abnormal audit delay.

Mathuva, Tauringana, and Owino (2019) examined the relationship between corporate governance and the timeliness of audited financial statements among listed firms in Kenya. The study used a sample size of five hundred and forty three (543) firm-year observations over the period 2007-2016, with the core objective to investigate whether validated Corporate Governance (CG) Index is associated with audit report delay (ARD), by applying both granular and aggregated analytical approaches. In the same vein, control variables were incorporated into the panel data regressions estimation and the result of the analyses shows that financial expertise among audit committee, board size, frequent board meetings and independence in the board are associated with longer ARDs. The estimation also shows that there is association between board diversity (women and different nationalities in the board) and timeliness of the annual reports. It was also revealed that the longer the tenure of independent directors in the board, the shorter ARD, while the analyses also shows that composite CG score has a positive influence on the timeliness of annual reports.

Eze and Nkak (2020) did a study on Nigeria quoted companies on the nexus between corporate governance and timeliness of audited reports. Using all the quoted companies on the Nigerian Stock Exchange as at 31<sup>st</sup> March 2018 as the population of the study, the study



generated secondary data from annual reports of the companies, while the formulated hypotheses were tested with the aid of regression model. The result of the regression estimation shows that there is a significant relationship between board composition and timeliness of audit report; which is indicative of the fact that late filers companies are likely to have boards with significantly lower numbers of independent Non-Executive Directors, audit committee members with financial expertise than their early filers companies. The estimation also revealed that there is significant positive relationship between board independent non-executive director and audit committee financial expertise with the timeliness of audited reports of companies respectively. On the whole, the study submitted that there is a significant positive relationship between corporate governance and timeliness of audit report.

#### **Audit committee independence and audit report lag**

Emeh and Ebimobowei (2013) examined the relationship between audit committee and timeliness of financial reports in Nigeria. The study used sample size of thirty five (35) companies quoted in the Nigerian Stock Exchange (NSE) covering the period 2007-2011. Analyses of data generated from the annual reports of the sampled companies were done with the aid of relevant diagnostic tests, pooled least square and granger causality test. The estimation results revealed that there is significant relationship between audit committee independence and timeliness of financial reports; insignificant relationship between audit committee meeting (ACM) and timeliness of financial reports; significant relationship between audit committee expertise (ACE) and timeliness of financial reports; and significant relationship between audit committee size (ACS) and timeliness of financial reports.

Akhor and Oseghale (2017) conducted a study on the relationship between audit committee attributes and financial reporting lag in Nigeria Banking sector. The study adopted quantitative and longitudinal research design, while a sample of all the quoted Banks in the Nigeria Stock Exchange were used in the study. Data were generated from the annual reports of the respective Banks for the period covering 2011 to 2015, and estimation of the data for purpose of test of hypotheses was done with the aid of descriptive statistic, ordinary least square regression and Ramsey Reset test. The result of the estimation revealed that there is a significant relationship between audit committee independence and financial reporting lag; insignificant relationship between audit committee

meeting, audit committee gender and financial reporting lag respectively.

#### **Audit committee size and audit report lag**

Ilaboya and Iyafekhe (2014) studied the relationship between corporate governance and audit report lag in Nigeria. The study utilised panel data of a sample of forty (40) manufacturing companies listed on the Nigeria Stock Exchange from a total population of one hundred and twenty (120) manufacturing companies for the period of five (5) years as well time series ranging from 2007-2011. Data estimation was conducted with the aid of descriptive statistics correlation and Ordinary Least Square (OLS) regression, and the result of the estimation shows that there is significant relationship between board size, audit firm type, firm size on audit report lag respectively, while it was also revealed that there is insignificant relationship between board independence, audit committee size and audit report lag respectively.

Ahmed and Che-Ahmad (2016) examined the effects of corporate governance characteristics on audit report lags in Nigeria using a sample of fourteen listed Banks in the Nigerian Stock Exchange (N.S.E). Considering a time series from 2008 to 2012, the study used robust ordinary least squares estimation model for purpose of analyses and test of hypotheses. The result of the estimation revealed that there is a significant relationship between audit quality and audit report lag (ARL). In the same vein, the study also found out that there is a significant positive relationship between board meetings, board size, total assets, board gender and ARL respectively. Furthermore, it was revealed that there is insignificant relationship between board expertise, risk committee size and audit committee size with ARL.

#### **Audit committee effectiveness and audit report lag**

Aljaaidi, Bagulaidah, Ismail, and Fadzil (2015) examined the determinants associated with audit report lag in Jordan. The study conducted a survey on eighty seven (87) external auditors of companies listed in Amman Stock Exchange (ASE) in Jordan, as well as obtained relevant information from the annual reports of the different companies for the year 2009. The data were analysed with the aid of Ordinary Least Square (OLS) regression techniques and the results shows that there is a significant relationship between an active audit committee (more frequent meetings) and audit report lag.

Alqublani (2016) investigated the relationship between audit committee characteristics and audit report lag in Malaysia. The study relied on a sample size of one hundred and thirty nine (139) companies as



of 2015 financial year. Data generated were estimated with the aid of descriptive and regression analyses and the result shows that on the average, ninety five (95) days was taken to complete companies audit report, given a maximum and minimum day of one hundred and twenty two (122) days and forty five (45) days respectively. In the same vein, the estimation shows that there is significant relationship between chairman of audit committee with accounting expertise, audit committee size, frequency of meetings of audit committee, firm size, leverage, profitability and audit report lag. In the same vein the regression analyses shows that there is insignificant relationship between audit committee independence, audit committee overlap, tenure of chairman of audit committee, auditor type, industry type and audit report lag.

#### 4.0 REVIEW OF THEORY

The following theory is relevant to this study:

##### *Agency theory*

Agency theory is one of the most cited theories relating to studies in the field of auditing. Agency theory was developed by Jensen and Meckling (1976) in an attempt to analyse the relationship between investors and managers in the context of relationship contract, notwithstanding an earlier attempt in the year 1949 by Professor Aldo Amaduzzi, an Italian in his book published and titled, *Conflitto ed equilibrio di interessi nel bilancio dell'impresa* (with an English translation, Conflict and Equilibrium of Interests in Corporate Financial Statements), wherein he analysed financial reports as the equilibrium outcome of the inherent conflicting interest between different stakeholders in an establishment.

Agency theory has direct bearing on this study based on the fact that the multiplicity of interests among diverse stakeholders as well as the integrity gaps created by such diverse interest will precipitates the need to have in place, an effective audit committee, which is needed to act on behalf of these stakeholders to perform due diligence and ensure that the audited report is presented in a timely manner, failure which will further amplify the conflicting interest inherent in the relationship between owners (stakeholders) and

managers of the organisations. Consequently, in explaining the relationship between audit committee characteristics and audit report lag, agency theory is thus relevant; hence this study will be anchored on agency theory.

#### 5.0 METHODOLOGY

This study used causal research design which describes association between variables. It is suited for this study because it allows for the establishment of relationship between variables that will be employed in the study and for making necessary prediction regarding the variables. The study will adopt the use of quantitative data from the Nigeria Stock Exchange up to 31<sup>st</sup> December 2020. The population of the study will be all the twenty (20) quoted insurance companies in the Nigeria Stock Exchange as of 31<sup>st</sup> December, 2020. For the purpose of sample size determination, convenient sampling technique was used to select five (5) insurance companies from all the insurance companies quoted on the floor of the Nigeria Stock Exchange.

##### Sources of Data Collection

The secondary source of data collection will be used. This will be achieved from the annual reports of the respective companies and the Nigeria Stock Exchange Fact Books for a six (5) year period from 2016-2020, thus making it a panel data collection.

The data which includes audit firm characteristics and audit report lag will be retrieved directly or through necessary computations from corporate annual reports of companies for 2016-2020 financial years. The use of corporate annual reports is premised on the fact that they are readily available, accessible and also provides a greater potential for comparability of results. More so, they are produced annually and kept in public sphere. In extracting the information, content analysis will be employed by the researcher. Content analysis method is one of the most used means of obtaining data from corporate annual reports. It enables data collected to be easily classified and compared.



### Model Specification

It is expected that there is a functional relationship between audit committee characteristics and audit report lag:

$$Arl = F(Acf, Aci, Acs, Ace) \dots\dots\dots (1)$$

equation 1 is transformed into econometric form as

$$Arl_{it} = \beta_0 + \beta_1 Acf_{it} + \beta_2 Aci_{it} + \beta_3 Acs_{it} + \beta_4 Ace_{it} + U_t \dots\dots\dots (2)$$

Where

**Arl** = audit report lag

**Acf** = audit committee financial expertise

**Aci** = audit committee independence

**Acs** = audit committee size

**Ace** = audit committee effectiveness

$U_t$  = stochastic error term

$\beta_1 - \beta_4$  = Regression coefficients

Apriori expectation

It is presumptively expected that the audit committee characteristics will have effect on audit report lag by reducing it in the organisations under consideration. That is  $\beta_1, \beta_2, \beta_3$  and  $\beta_4 > 0$

## 6.0 DATA ANALYSES AND PRESENTATION

### Descriptive Statistics

	ARL	ACF	ACI	ACS	ACE
Mean	109.1600	1.680000	0.440000	5.400000	4.920000
Median	109.0000	1.000000	0.000000	6.000000	5.000000
Maximum	145.0000	3.000000	1.000000	6.000000	7.000000
Minimum	69.00000	1.000000	0.000000	4.000000	4.000000
Std. Dev.	22.11839	0.802081	0.506623	0.816497	0.759386
Skewness	0.087443	0.629772	0.241747	-0.843750	0.712247
Kurtosis	2.055210	1.891071	1.058442	2.078125	3.630275
Jarque-Bera	0.961679	2.933516	4.170224	3.851573	2.527529
Probability	0.618264	0.230672	0.124293	0.145761	0.282588
Sum	2729.000	42.00000	11.00000	135.0000	123.0000
Sum Sq. Dev.	11741.36	15.44000	6.160000	16.00000	13.84000
Observations	25	25	25	25	25

*Source: Researcher Computation using Eviews 8.0*

The result of the descriptive analysis is presented in the Table above. The mean ARL is 109.1600 with a maximum value of 145.0000 and minimum value 69.00000. The average ACF is 1.680000 with a maximum value of 3.000000 and a minimum value of 1.000000. The mean ACI is 0.440000 with maximum value of 1.000000 and minimum value of 0.000000. In the same vein, the mean ACS is 5.400000 with maximum value of 6.000000 and minimum value of 4.000000; while the mean ACE is 4.920000 with maximum value of

7.000000 and minimum value of 4.000000. The standard deviations are 22.11839, 0.802081, 0.506623, 0.816497, and 0.759386 for ARL, ACF, ACI, ACS and ACE respectively. All variables but ACS exhibit positive Skewness. The Kurtosis values are 2.055210, 1.891071, 1.058442, 2.078125, and 3.630275 for ARL, ACF, ACI, ACS and ACE respectively. The Jarque-Bera statistics 0.961679, 2.933516, 4.170224, 3.851573, and 2.527529 are for ARL, ACF, ACI, ACS and ACE respectively.





## CORRELATION MATRIX

Covariance Analysis: Ordinary  
 Date: 04/26/21 Time: 10:25  
 Sample: 2016 2020  
 Included observations: 25

Covariance	ARL	ACF	ACI	ACS	ACE
ARL	469.6544				
ACF	-7.708800	0.617600			
ACI	1.249600	-0.019200	0.246400		
ACS	3.976000	0.008000	0.184000	0.640000	
ACE	3.012800	0.054400	-0.044800	0.032000	0.553600

*Source: Researcher Computation using Eviews 8.0*

The result of the correlation analysis is presented in the table above. The result of the analysis show negative correlation between ARL and AC; while there is positive correlation between ARL and ACI, ACS and ACE respectively. The correlation between ACF and ACI is negative, while there is positive

correlation between ACF and ACS, and ACE respectively. ACI is positively correlated with ACS, but negatively correlated with ACE, while ACS is positively correlated with ACE.

## Regression Result Output

Dependent Variable: ARL  
 Method: Panel Least Squares  
 Date: 04/26/21 Time: 10:28  
 Sample: 2016 2020  
 Periods included: 5  
 Cross-sections included: 5  
 Total panel (balanced) observations: 25

Variable	Coefficient	Std. Error	t-Statistic	Prob.
C	67.66238	38.24794	1.769046	0.0921
ACF	-13.09860	5.158131	-2.539408	0.0195
ACI	0.899797	9.302835	0.096723	0.9239
ACS	5.794179	5.733877	1.010517	0.3243
ACE	6.467234	5.520904	1.171409	0.2552
R-squared	0.307931	Mean dependent var		109.1600
Adjusted R-squared	0.169517	S.D. dependent var		22.11839
S.E. of regression	20.15668	Akaike info criterion		9.021805
Sum squared resid	8125.835	Schwarz criterion		9.265580
Log likelihood	-107.7726	Hannan-Quinn criter.		9.089418
F-statistic	2.224710	Durbin-Watson stat		2.165364
Prob(F-statistic)	0.102821			

*Source: Researcher Computation using Eviews 8.0*



The regression result output above shows that audit committee financial expertise (ACF) has a significant negative relationship with audit report lag (ARL), while audit committee independence (ACI), audit committee size (ACS) and audit committee effectiveness (ACE), on the average has insignificant positive relationships with audit report lag (ARL) in the insurance sub-sector of the Nigerian economy.

## 7.0 CONCLUSION

This study is an empirical investigation of the relationship between audit committee characteristics and audit report lag in Nigeria insurance sub-sector. The explanatory variables which makes up audit committee characteristics comprises of audit committee financial expertise (ACF), audit committee independence (ACI), audit committee size (ACS) and audit committee effectiveness (ACE). The study used panel data of five (5) listed Insurance companies obtained from their respective annual reports covering the period 2016-2020. The data were estimated with the Panel Least Square (PLS) regression estimation technique, and the result of the analyses shows that audit committee financial expertise (ACF) has a significant negative relationship with audit report lag (ARL), while audit committee independence (ACI), audit committee size (ACS) and audit committee effectiveness (ACE), on the average has insignificant positive relationships with audit report lag (ARL) in the insurance sub-sector of the Nigerian economy.

## REFERENCES

- Ahmed, M.I. & Che-Ahmad, A. (2016). *Effects of corporate governance characteristics on audit report lags. International Journal of Economics and Financial Issues*, 6(7) 159-164.
- Akhor, S.O. & Oseghale, E.O. (2017). *An empirical investigation of audit committee attributes and financial reporting lag in Nigeria Banking sector. Journal of Accounting and Financial Management*, 3(2), 25-38.
- Al-Ajmi, J. (2008). *Audit and reporting delays: Evidence from an emerging market. Advances in Accounting*, 24(2), 217-226.
- Aljaaidi, K.S., Bagulaidah, G.S., Ismail, N.A., & Fadzil, F.H. (2015). *An empirical investigation of determinants associated with audit report lag in Jordan. Jordan Journal of Business Administration*, 11(4), 963-980.
- Alqublani, A.A.M. (2016). *Audit committee characteristics and audit report lag in Malaysia. Thesis Submitted to Tunku Puteri Intan Safinaz School of Accountancy, Universiti Utara Malaysia.*
- Baatwah, S.R., Salleh, Z., & Stewart, J. (2019). *Audit committee chair accounting expertise and audit report timeliness: The moderating effect of chair characteristics. Asian Review of Accounting*, 27(2), 273-306.
- Bamber, E.M., Bamber, L.S., & Schoderbek, M.P. (1993). *Audit structure and other determinants of audit report lag: An empirical analysis. Auditing: A Journal of Practice & Theory*, 12(1): 1-23.
- Beaver, W.H. (1968). *The information content of annual earnings announcements. Journal of Accounting Research*, 6, 67-92.
- Companies and Allied Matters Act (CAMA) 2020 *Laws of the Federation of Nigeria, 2020*
- Courtis, J. K. (1976). *Relationships between timeliness in corporate reporting and corporate attributes, Accounting and Business Research (Winter): 45-76. delay in Hong Kong. British Accounting Review*, (26): 43-59.
- Dibia, N.O. & Onwuchekwa, J.C. (2013). *An examination of the audit report lag of companies quoted in the Nigeria Stock Exchange. International Journal of Business and Social Research (IJBSR)*, 3(9), 8-16.
- Emeh, Y. & Ebimobowei, A. (2013). *Audit committee and timeliness of financial reports: Empirical evidence from Nigeria. Journal of Economics and Sustainable Development*, 4(20), 14-25.
- Eze, P.G., & Nkak, P.E. (2020). *Corporate governance and timeliness of audited reports of quoted companies in Nigeria. International Journal of Business and Management Invention*, 9(1), 38-46.
- Firnanti, F. & Karmudiandri, A. (2020). *Corporate governance and financial ratios effect on audit report lag. Accounting and Finance Review Journal*, 5(1), 15- 21.
- Ghafran, C. & Yasmin, S. (2017). *Audit committee chair and financial reporting timeliness: A focus on financial, experiential and monitoring expertise. International Journal of Audit*, 1-12.
- Habib, A. & Bhuiyan, M.B.U. (2011). *Audit firm industry specialization and the audit report lag. Journal of International Accounting, Auditing and Taxation*, 20(1), 32-44.
- Ilaboya, O.J. & Iyafekhe, C. (2014). *Corporate governance and audit report lag in Nigeria. International Journal of Humanities and Social Science*, 4(13), 172-180.
- Jensen, M.C., & Meckling, W.H. (1976). *Theory of the firm: Managerial behavior, agency costs and ownership structure. Journal of Financial Economics*, 3(4), 305-360.
- Juwita, R., Sutrisno, T., & Hariadi, B. (2020). *Influence of audit committee and internal audit on audit report lag: Size of public accounting firm as a moderating variable. International Journal of Research in Business and Social Science*, 9(1), 137-142.



20. Kusin, S.A.B. & Kadri, M.H.B. (2020). *Determinants of audit report lag: Effect of corporate governance in listed companies in the Malaysian construction industry. Asia-Pacific Management Accounting Journal, 15(3), 109-140.*
21. Mathuva, D.M., Tauringana, V., & Owino, F.J.O. (2019). *Corporate governance and the timeliness of audited financial statements: The case of Kenyan listed firms. Journal of Accounting in Emerging Economies, 9(4), 473-501.*
22. Mohamad-Nor., N.M., Shafie., R. & Wan-Hussin., W. N. (2010). *Corporate governance and audit report lag in Malaysia. Asian Academy of Management Journal of Accounting and Finance. 6(2), 57-84.*
23. Odjaremu, G.O. & Jeroh, E. (2019). *Audit committee attributes and the reporting timeliness of listed Nigerian firms. Trends Economics and Management, 34(2), 69-81.*
24. Raweh, N.A.M., Kamardin, H., & Malik, M. (2019). *Audit committee characteristics and audit report lag: Evidence from Oman. International Journal of Accounting and Financial Reporting, 9(1), 152-169.*
25. Rusmanto, T., & Herlina, M. (2020). *The connection between corporate governance and audit report lag: An Indonesian case. American International Journal of Business Management, 3(8), 67-73.*
26. Salleh, Z., Baatwah, S.R. & Ahmad, N. (2017). *Audit committee financial expertise and audit report lag: Malaysia further insight. Asian Journal of Accounting and Governance, 8: 137-150.*
27. Soyemi, K.A., Sanyaolu, W.A., & Salawu, R.O. (2019). *Corporate governance practices and external auditor' reporting lag in Nigeria. Accounting and Taxation Review, 3(4), 15-31.*
28. Warrad, L.H. (2018). *The extent to which the corporate governance characteristics has affected the audit report lag in Jordanian Banks. International Journal of Business and Management, 13(12), 81-92.*



# WHISTLE-BLOWING AS A FRAUD PREVENTION STRATEGY IN NIGERIA

<sup>1</sup>Izevbigie, D.P.I., <sup>2</sup>Omozusi, O.F.

<sup>1</sup>Ph.D. Student, Department of Accounting, Faculty of Management Sciences, University of Benin, Benin City

<sup>2</sup>M.Sc. Forensic Accounting Student, Department of Accounting, Faculty of Management Sciences, University of Benin, Benin City

---

## ABSTRACT

*This study examines the effectiveness of whistle-blowing as a fraud prevention strategy. Using the survey method of data gathering, a total of eighty (80) copies of likert-scale questionnaire were distributed to respondents. A total of seventy (70) copies of questionnaire were retrieved for the purpose of data analyses using chi-square, to test our hypotheses. Our study reveals that whistle-blowing is a good fraud prevention strategy, the public has a positive perception towards whistle-blowing and that there is protection for whistle-blower in Nigeria. It is therefore recommended that whistle-blowing be encourage and given the needed legal teething in Nigeria in order to serve as catalyst for fraud prevention.*

---

## INTRODUCTION

### 1.1 BACKGROUND TO THE STUDY

Whistle-blowing strategy has been used by several organisations over the years in both public and private sectors to bring to the attention of the public and concern stakeholders in the event of fraud or suspected fraud. But whether it has aided fraud prevention is yet another contentious issue begging for adequate explanation.

Kirklees Council (May 2012) in the United Kingdom (UK), opined that employees will often be the first to notice if there is something seriously wrong within their workplace. Sometimes it may seem difficult to speak up because of feelings of disloyalty, or because of a fear of harassment or victimisation. They asserted that they expect the highest standards of behaviour and that all employees have a responsibility to voice any concerns they have, normally with their manager or assistant director by way of whistleblowing. They maintained that this whistleblowing procedure is independent and confidential. According to Kirklees Council (May 2012), It can be anonymous if you wish and also make sure that you will not be victimised or suffer disadvantage if you report your genuine concerns.

Whistleblowing is a strategy which allows employees to bring to the attention of those who can make a difference any practice which they believe or suspect is unlawful, serious breach of the organisation's policies, procedures and rules that falls substantially below established standards of practice and amounts to improper conduct.

Daft (2006), argued that organisations can no longer rely solely on codes of conduct and ethical structures to prevent all unethical behaviour, but have to depend to some degree on individuals who are willing to blow the whistle if they detect illegal, dangerous or unethical activities. However Borrie and Dehn (2003) lament the rapid advances in the transformation of the modern organisation for making it increasingly impracticable for most organisations to have the necessary checks and controls in place, and this makes it easier for employers and employees to act in ways that compromise their professional integrity. Perks and Smith (2009) submitted that Whistle-blowing is contrary to the tradition that an employee does not question a superior's decisions and acts, especially not in public. What is at stake is the employee's right to speak out in cases where they think the organisation or management is engaging in an unacceptable practice.



## 1.2 STATEMENT OF THE RESEARCH PROBLEM

An attempt by employees to come up with whistle-blowing in the event of suspected fraud has not yielded positive results in Nigeria over the years. For instance, thisdaylive newspaper had reported that the former Central Bank of Nigeria (CBN) governor, Mallam Sanusi Lamido Sanusi raised alarm between the year 2013-2014 that certain amount of money was not remitted to the designated account in CBN by the Nigeria National Petroleum Corporation (NNPC), this became a subject of public debate and caused a lot of controversy, however instead of proper accountability and probity to be done by the concern authorities and anti-graft agencies, it resulted in accusations and counter accusations among the parties involve.

According to thisdaylive newspaper, the federal government even went as far as accusing the whistle-blower of mere politicking rather than face the issue with sincerity of purpose. The whistle-blower was subsequently suspended till retirement. However on the international scale, Federation of International Football Association (FIFA), reported that a front-line member of the Federation of International Football Association (FIFA), in the year 2014 also raised alarm that the process of the award of hosting rights of the FIFA World Cup for 2018 and 2022 to Russia and Qatar respectively was fraudulent and that certain members accepted bribes. But when asked to come forward with evidence, he became defiant and declined to mention those culpable.

Perks and Smith (2009) maintained that in whistleblowing, what is at stake is employee's right to speak out in cases where they think the organisation or management is engaging in an unacceptable practice. But in the Nigeria context, what becomes of the employees in terms of job security, public acceptance and of course the potential long run spillover effect of blowing the whistle in situations where organisations are suffering from bureaucratic red-tapism and organisations code of conduct do not encourage whistleblowing. On the other hand, many serious scandals and disasters that have occurred all over the world in recent years might have been prevented or lessened if employees had come forward to expose problems to regulators or the media. This study is designed to explore the relevance of whistle-blowing as a strategy for fraud prevention in Nigeria. Therefore, the following questions will be used to address these problems:

1. How does whistle-blowing strategy aid fraud prevention?

2. What is the perception of the public towards whistle-blowing strategy?  
 3. To what extent are whistle-blower protected in Nigeria?

## 1.3 OBJECTIVES OF THE STUDY

The general objective is to ascertain the effectiveness of whistle-blowing in fraud prevention. The specific objectives are to:

1. Establish the effect of whistle-blowing on fraud prevention;
2. Ascertain public perception towards whistle-blowing; and
3. Determine the extent to which whistle-blower are protected in Nigeria.

## 1.4 HYPOTHESES

For the purpose of this study, the following hypotheses will be tested:

- H<sub>01</sub>. Whistle-blowing is not a good fraud prevention strategy.  
 H<sub>02</sub>. The public has a negative perception towards whistle-blowing.  
 H<sub>03</sub>. There is no protection for whistle-blower in Nigeria.

## LITERATURE REVIEW

### INTRODUCTION

This session will be used to review relevant and related literatures on whistle-blowing as a tool for fraud prevention.

### CONCEPTUAL FRAMEWORK

Near and Miceli (1987), defined whistle-blowing as the disclosure by organisation members (former or current) of illegal, immoral or illegitimate practices under the control of their employers, to persons or organizations that may be able to effect action. Barker and Dawood (2004) recommended that organisations should implement an effective internal system for employees to raise concerns and to facilitate the process of whistle-blowing internally. Meanwhile Robbins and Judge (2006) encourage ethical training to implement an ethical organisational culture. They asserted that the training should be given to new employees as part of orientation, as well as to existing employees. This training should be given on a periodic basis to help employees recognise ethical dilemmas and to make them aware of the ethical issues underlying any action they take.

Sangweni (2005) pointed out several initiatives that have been undertaken in South Africa by government to promote accountability and fight





corruption within the public sector. These include legislation on the Promotion of Access to Information Act and the Protected Disclosure Act. This Act aims to protect persons from victimisation when they expose corruption and unethical practices while government has also hosted various anti-corruption conferences. Perks and Smith (2009) opined that whistle blowing often involves a decision to be made among conflicting moral, legal, economic, personal, family, and career demands and choices. According to Meng and Fook (2011), the fact that many countries have enacted legislations to protect whistleblowers exemplifies the importance of whistle-blowing in promoting good governance within both the public and private institutions. They argued that Malaysia also showed its commitment in eradicating corporate fraud, corruption and misbehaviour through the enactment of the Whistleblower protection ACT 2010 (WPA 2010), maintaining that there is still a bridging gap between whistleblower protection and good corporate governance practices in Malaysia compared to England and the United States.

However, The Central Bank of Nigeria (CBN) recently introduced a new Code of Corporate Governance and Whistle Blowing guidelines, directing banks to formulate whistle-blowing policies and acquaint employees and stakeholders of same. The policies are to contain mechanisms, including assurances of confidentiality that would encourage stakeholders to report any unethical activity to the bank and/or the CBN. Over and above this, banks are expected to render reports on quarterly basis on compliance with regards to whistle-blowing policies.

Whistleblower protection mechanisms and assurances of confidentiality is a means of promoting accountability by allowing for the disclosure by any person of information (internal and external) about misconduct, whilst at the same time protecting the person against sanctions of any form.

Transparency international maintained that whistleblowers are important players in national and global efforts to fight corruption. They risk their careers and sometimes their personal safety to expose wrongdoing that threatens public health and safety, financial integrity, human rights, the environment, and the rule of law. By disclosing information about such misdeeds, whistleblowers have helped save countless

lives and billions of dollars in public funds while preventing emerging scandals and disasters from worsening. Many serious scandals and disasters that have struck Europe in recent years might have been prevented or lessened if employees had come forward to expose problems to regulators or the media. Inadequate whistleblower laws can inhibit people from taking this step.

### THEORETICAL FRAMEWORK

**Shareholder Theory:** Friedman (Shareholder Theory) argued that employees DO have SOME obligations to their employers. If you work for someone (public or private organisations), they have almost certainly hired you for a specific purpose: Namely, to help out that business, and serve their interests. In short, when you are hired by an employer, you enter into some form of contract with that employer; to the effect that you agree to work toward the interests of the business, and in return they will compensate you accordingly. Hence where there is fraud or organisational anomaly within the knowledge of employee, he/she should not hesitate to raise alarm. This study will therefore be anchored on Friedman (Shareholder Theory).

### METHODOLOGY

The analyses of data in this research will be done by chi-square, while likert scale questionnaire will be used to generate data.

### MODEL SPECIFICATION

$$\chi^2 = \sum_{i=1}^r \sum_{j=1}^c (o_{ij} - e_{ij})^2 / e_{ij}$$

Where  $o_{ij}$  = observed frequency in the  $i$ th row and  $j$ th column

$e_{ij}$  = expected frequency in the  $ij$ th cell

$e_{ij} = (\text{ith row total} \times \text{jth column total}) / \text{grand total}$

### DECISION RULE

*Reject  $H_0$ : if  $\chi^2_{\text{calculated}} > \chi^2_{\text{tabulated}}$*

*Don't Reject  $H_0$ : if  $\chi^2_{\text{calculated}} < \chi^2_{\text{tabulated}}$*

### DATA PRESENTATION, ANALYSES AND INTERPRETATION

A total of eighty (80) copies of likert-scale questionnaire were distributed to respondents, but seventy (70) were return completed.



## DEMOGRAPHIC ANALYSES OF RESPONDENTS

### Sex Distribution

Table 1.0

Sex	Respondents	Percentage (%)
Male	45	64
Female	25	36
Total	70	100

Source: field survey, 2021.

### Age Distribution

Table 1.1

Age	Respondents	Percentage (%)
25-30	30	43
31-35	15	21
36 and above	25	36
Total	70	100

Source: field survey, 2021.

### Educational Qualification

Table 1.2

Qualifications	Respondents	Percentage (%)
WASCE	-	-
OND/NCE	-	-
B.Sc./B.A	65	93
M.Sc./Ph.D.	5	7
Others	-	-
Total	70	100

Source: field survey, 2021.

## TEST OF HYPOTHESES

$H_{01}$ . Whistle-blowing is not a good fraud prevention strategy.

Table 1.3a

Items/ Questions	SA $O_{ij},(e_{ij})$	A $O_{ij},(e_{ij})$	U $O_{ij},(e_{ij})$	D $O_{ij},(e_{ij})$	SD $O_{ij},(e_{ij})$	Total
1	11,(14.2)	16,(11.8)	6,(11)	21,(21)	16,(12)	70
2	6,( 14.2)	0,(11.8)	15,(11)	38,(21)	11,( 12)	70
3	11,(14.2)	16,(11.8)	6,(11)	16,(21)	21,( 12)	70
4	20,(14.2)	15,(11.8)	15,(11)	15,(21)	5,(12)	70
5	23,(14.2)	12,(11.8)	13,(11)	15,(21)	7,(12)	70
Total	71	59	55	105	60	350

Source: field survey, 2021.



Table 1.3b

$O_{ij}$	$e_{ij}$	$(O_{ij}-e_{ij})^2$	$(O_{ij}-e_{ij})^2 / e_{ij}$
11	14.2	10.24	0.72
16	11.8	17.64	1.49
6	11	25	2.27
21	21	0	0
16	12	16	1.33
6	14.2	67.24	4.74
0	11.8	139.24	11.8
15	11	16	1.45
38	21	289	13.76
11	12	1	0.08
11	14.2	10.24	0.72
16	11.8	17.64	1.49
6	11	25	2.27
16	21	25	1.19
21	12	81	6.75
20	14.2	33.64	2.36
15	11.8	10.24	0.87
15	11	16	1.45
15	21	36	1.71
5	12	49	4.08
23	14.2	77.44	5.45
12	11.8	0.04	0
13	11	4	0.36
15	21	36	1.71
7	12	25	2.08
<b><math>\chi^2</math> calculated =</b>			<b>70.13</b>

Source: author's computation

$\chi^2$  tabulated, d.f = (r-1)(c-1), level of significant= 0.05

$\chi^2$  tabulated 16, 0.05 = 26.296

Decision: Reject the null hypothesis and accept alternate hypothesis. That is on the average, whistle-blowing is a good fraud prevention strategy.

**H<sub>02</sub>. The public has a negative perception towards whistle-blowing.**

Table 1.4a

Items/ Questions	SA $O_{ij},(e_{ij})$	A $O_{ij},(e_{ij})$	U $O_{ij},(e_{ij})$	D $O_{ij},(e_{ij})$	SD $O_{ij},(e_{ij})$	Total
6	0,(1.67)	20,(21.67)	0,(6.67)	40,(28.33)	10,(11.67)	70
7	5,(1.67)	20,( 21.67)	10,(6.67)	25,(28.33)	10,(11.67)	70
8	0,(1.67)	25,( 21.67)	10,(6.67)	20,(28.33)	15,(11.67)	70
Total	5	65	20	85	35	210

Source: field survey, 2021.



Table 1.4b

<i>Oij</i>	<i>eij</i>	$(Oij-eij)^2$	$(Oij-eij)^2 / eij$
0	1.67	2.79	1.67
20	21.67	2.79	0.13
0	6.67	44.49	6.67
40	28.33	136.19	4.81
10	11.67	2.79	0.24
5	1.67	11.09	6.64
20	21.67	2.79	0.13
10	6.67	11.09	1.66
25	28.33	11.09	0.39
10	11.67	2.79	0.24
0	1.67	2.79	1.67
25	21.67	11.09	0.51
10	6.67	11.09	1.66
20	28.33	69.39	2.45
15	11.67	11.09	0.95
<b><math>\chi^2</math> calculated =</b>			<b>29.82</b>

Source: author's computation

$\chi^2_{tabulated}$ , d.f = (r-1)(c-1), level of significant= 0.05

$\chi^2_{tabulated}$  8, 0.05 = 15.507

Decision: Reject the null hypothesis and accept alternate hypothesis. That is on the average, the public has a positive perception towards whistle-blowing.

H<sub>03</sub>. There is no protection for whistle-blower in Nigeria.

Table 1.5a

Items/ Questions	SA <i>Oij,(eij)</i>	A <i>Oij,(eij)</i>	U <i>Oij,(eij)</i>	D <i>Oij,(eij)</i>	SD <i>Oij,(eij)</i>	Total
9	5,(2.5)	15,(17.5)	5,(2.5)	30,(30)	15,(17.5)	70
10	0,(2.5)	20,( 17.5)	0,(2.5)	30,( 30)	20,(17.5)	70
Total	5	35	5	60	35	140

Source: field survey, 2021.

Table 1.5b

<i>Oij</i>	<i>eij</i>	$(Oij-eij)^2$	$(Oij-eij)^2 / eij$
5	2.5	6.25	2.5
15	17.5	6.25	0.36
5	2.5	6.25	2.5
30	30	0	0
15	17.5	6.25	0.36
0	2.5	6.25	2.5
20	17.5	6.25	0.36
0	2.5	6.25	2.5
30	30	0	0
20	17.5	6.25	0.36
<b><math>\chi^2</math> calculated =</b>			<b>11.44</b>

Source: author's computation

$\chi^2_{tabulated}$ , d.f = (r-1)(c-1), level of significant= 0.05

$\chi^2_{tabulated}$  4, 0.05 = 9.488



Decision: Reject the null hypothesis and accept the alternate hypothesis. That is on the average, there is protection for whistle-blower in Nigeria.

10. Thisdaylive *Newspaper*; Non-Remittance of \$49.8 Billion. Available at [www.thisdaylive.com](http://www.thisdaylive.com)

## CONCLUSION

The purpose of this study was to examine the effect of whistle-blowing as a fraud prevention strategy. The study concludes that whistle-blowing is a good fraud prevention technique and that the public has a positive perception towards whistle-blowing. Consequently, it is recommended that whistle-blowing be encourage and given the needed legal teething in Nigeria in order to serve as catalyst for fraud prevention.

## REFERENCES

1. Barker, R., & Dawood, R.(2004). *Whistle blowing in the organisation: Wrongdoer or do-gooder?* *Communicare*, 23(2), 119-138.
2. Borrie, G.& Dehn, G. (2003). *Whistle-blowing: the new perspective*. Retrieved September 16, 2007, from the World Wide Web: <http://www.pcaw.co.uk/policy-pub/niewperspective.html>.
3. Daft, R.L. (2006) *The new era of management*. International edition. Australia: South Western Thompson.
4. FIFA; Available at [www.fifa.com](http://www.fifa.com) Kirklees Council (May 2012) *Kirklees council Anti-fraud Anti-corruption & Anti-bribery Strategy*
5. Meng, T. P. & Fook, O. S. (2011). *Comparative analysis of whistleblower protection legislations in England, USA and Malaysia*. Faculty of Accountancy and Management, University Tunku Abdul Rahman (UTAR), Lot PT 21144, Jln Sungai Long, Bandar Sg Long, Cheras, 43000 Kajang, Selangor, Malaysia. *African Journal of Business Management* 5(27), 11246-11255. DOI: 10.5897/AJBM11.1332. Available online at <http://www.academicjournals.org/AJBM>
6. Near, J. & Miceli, M. (1987). *Organizational dissidence: The case of whistle-blowing*. *J. Bus. Ethics*, 1-16.
7. Perks, S. & Smith, E.E. (2009). *Employee perceptions regarding whistle-blowing in the workplace: A South African perspective*. *SA Journal of Human Resource Management*, 6(2)15-24.
8. Robbins, S. P., & Judge, T. A. (2006). *Organizational behaviour*. (12Ed.). New Jersey: Pearson Education.
9. Sangweni, S.(2005). *Parliamentary briefing on the 2005 Annual state of the Public service Report*. Retrieved September 17, 2007, from the World Wide Web: <http://www.pmg.org.za/briefings/briefings.php?id=185>.





# SCOPE OF MENTORING IN NURSING - A REVIEW

<sup>1</sup>Ms. Beulah Jasmine Rao, <sup>2</sup>Dr. Ashok Dhanwal

<sup>1</sup>Assistant Professor, Pursuing PhD In Nursing, Mangalayatan University Extended NCR 33rd Milestone, Aligarh-Mathura, Highway, Beswan, Uttar Pradesh 202145

<sup>2</sup>PhD in Nursing, Assistant Professor, Mangalayatan University Extended NCR 33rd Milestone, Aligarh-Mathura, Highway, Beswan, Uttar Pradesh 202145

---

## ABSTRACT

*The importance of integrating the mentoring system for enhancing students' performance is a common resolution that is to be adopted by faculty. With a wide variation in the student population in regard to educational and economic background, the system should promise to provide a better understanding of individual students and bring out their highest potential. It also appears to be the most effective method/weapon for mitigating cases of those students who are vulnerable to drop-out from studies.*

**KEY WORDS-** *Multidisciplinary Collaboration, NAAC Accreditation System, Generic Competencies,*

---

## INTRODUCTION

The importance of mentorship within health care training is well recognized. It offers a means to further enhance workforce performance and engagement, promote learning opportunities and encourage multidisciplinary collaboration. Many studies suggest that there are both career and life benefits associated with mentorship, and it is increasingly recognized as a bidirectional process that benefits both mentors and mentees. Recently, mentoring has been considered an essential step in professional and personal development, particularly in the field of health care.

Mentoring involves both coaching and an educational role, requiring a generosity of time, empathy, a willingness to share knowledge and skills, and an enthusiasm for teaching and the success of others. Being mentored is believed to have an important influence on personal development, career guidance and career choice. And through mentorship programs the students are encouraged to seek guidance on academic, general or psychological issues, if necessary.

India has one of the largest and diverse education systems in the world. Privatization, widespread expansion, increased autonomy and

introduction of Programmes in new and emerging areas have improved access to higher education. At the same time, it has also led to widespread concern on the quality and relevance of the higher education

The NAAC accreditation system also has placed the emphasis in all new curricula on generic competencies, it also emphasized that there is also a need to enhance the transferability of leadership, teamwork and decision-making skills, as well as expecting the nurse to be able to deliver nursing care and expand their scope of professional practice.

Successful mentoring relationships can assist nurses in learning the ropes at an organization, increase career satisfaction, and decrease turnover rates. Mentoring success is reliant on the health of the workplace, protégé and mentor characteristics, and the quality of the mentoring relationship.

The organizational benefits integrate with the protégé and mentor benefits. Mentoring programs have a positive impact on nurse retention, transition of the newly licensed nurse at both the RN and APRN levels, and nurse satisfaction and engagement. Mentoring has been used to decrease bullying, improve the workplace, and in succession planning at all levels of nursing. Through increased nurse satisfaction and



engagement, mentoring may also support the improvement of patient satisfaction and outcomes.

Such mentorship programs can be seen as a form of continuing professional development and while they can provide students with a form of professional enhancement which focuses on their needs providing them with advice, encouragement and empathy. Mentoring can be carried out on a formal basis (i.e. part of an association mentoring program), or informally (i.e. not supported by an administrative framework but rather a casual networking arrangement).

### CONCLUSION

Mentoring can foster the leadership skills that student nurses need to secure larger roles in developing, designing and delivering health care. Mentoring relationships inside healthcare organizations and academic institutions can help those organizations retain nurses and nurse educators, reducing the cost of turnover. The ideal mentor is not always the most experienced or the most productive, but rather an effective communicator who is accessible and willing to enter into a mentoring relationship. Establishing and maintaining the mentor-mentee relationship cannot be

overemphasized because it is the relationship that serves as the cornerstone for mentoring success.

### REFERENCES

1. Allen, S. (2006). *Mentoring: The magic partnership*. *Canadian Operating Room Journal*, 24 (4), 30.
2. Anderson, L. (2011). *A learning resource for developing effective mentorship in practice*. *Nursing Standard*, 25 (51), 48–56.
3. Barker, E. R. (2006). *Mentoring—a complex relationship*. *Journal of the Academy of Nurse Practitioners*, 18, 56–61.
4. Benner, P. (2004). *Using the Dry fuss model of skill acquisition to describe and interpret skill acquisition in nursing practice and education*. *Bulletin of Science Technology & Society*, 24 (3), 188–199.
5. Billings, D. & Kowalski, K. (2008). *Developing your career as a nurse educator: The importance of having (or being) a mentor*. *The Journal of Continuing Education in Nursing*, 39(11), 490–491.
6. Blauvelt, M., & Spath, M. (2008). *A faculty mentoring program: At one school of nursing*. *Nursing Education Perspectives*, 29 (1), 29–33.



**Ms. Beulah Jasmine Rao** Assistant Professor, Pursuing PhD In Nursing, Mangalayatan University Extended NCR 33rd Milestone, Aligarh-Mathura, Highway, Beswan, Uttar Pradesh 202145



# Effect of Different Animal Organic Manures on the Biometric and Nutrient Parameters of *Coriandrum sativum* L

<sup>1</sup>Maria Puspham Grace.M, <sup>2</sup>Rajithra.R, <sup>3</sup>V.Ilakkiya,  
<sup>4</sup>Dr. B. Dhanalakshmi

<sup>1,2,3,4</sup>Department of Zoology, Nirmala College for Women, Bharathiyar University,  
Coimbatore-18

Corresponding author: Dr. B. Dhanalakshmi and V. Ilakkiya

Article DOI: <https://doi.org/10.36713/epra7522>

DOI No: 10.36713/epra7522

## ABSTRACT

*In recent years, use of livestock manure and marine bio-waste has been advocated in integrated nutrient management (INM) system in vegetable crops. Poultry manure is an excellent organic fertilizer, is concentrated source of nitrogen and other essential nutrients. In the present study the culinary herb Coriandrum sativum which has medicinal property was selected as experimental plant whose biometric parameters were analyzed in different treatment pots amended with different organic poultry and fish manure. The productivity of Coriander is influenced by several factors such as soil, varieties, fertilizer management, and also various agro techniques used for growing crop. With this context in the present experimental study two animal wastes converted to organic manure by Eudrilus eugeniae-Worm into poultry and fish manure in organic farm of Rajapalayam District was purchased and amended in 2kg garden soil in selected ratios namely 25% (T<sub>2</sub>), 50%(T<sub>3</sub>),75%(T<sub>4</sub>) and 100%(T<sub>5</sub>). (T<sub>1</sub>) was maintained as control in which no amendment was made. Coriander seed were purchased from TNAU, Coimbatore. The experimental findings pertaining to the present investigation reveals the effect of poultry manure has been higher than fish manure on the growth parameters and NPK of coriander (Coriandrum sativum L.). So the ultimate goal is to develop farming systems that are productive, energy conserving, environmentally sound conserving of natural resources such as soil and water and thus ensure food safety and quality.*

**KEYWORDS:** Manure, Coriander, Poultry and Eudrilus eugeniae

## INTRODUCTION

Nutrient availability is critical in efficient agriculture production systems. Conventional agriculture uses chemical fertilizers which have several possible negative side effects. These are often associated with soil degradation and depletion as well as water and soil pollution. (Grubinger, 1999) noted that chemical fertilizers are made up of minerals which dissolve rapidly in damp soil resulting in rapid availability of large doses of minerals to the plants. Furthermore, excessive use of urea fertilizer which contains nitrogen (N) may lead to soil and groundwater contamination further affecting the environment.



Modern research has identified alternative agricultural methods that lead to good yields and enhanced soil fertility without using chemical components. Organic agriculture is one of the agricultural forms that often depend on using green manure, compost, and biological pest management. India stands second in global fish production with an annual fish production of around 10 million metric tons. Around 85% of fish produced is consumed in the fresh form (DAHD, 2014) and 10.51 lakh tons is exported. India is home to more than 60 minor fishing harbors, around 1500 fish landing centers, 350 seafood processing factories and innumerable number of fish markets where a huge amount of processing waste is being generated. Fish marketing and processing operations produce waste in the solid form like fish carcasses, viscera, skin and heads. Quantum of waste generated through fish processing varies from 10% to 80% of the weight of the fish according to the processing activities. Presently in India, around 960 million tons of solid waste is being generated. By 2050, our country would need 9 times the area of land for dumping of wastes which we all know is not feasible taking into account the exponential population growth.

Coriander is one of the important spice crop grown throughout the world and botanically known as *Coriandrum sativum* Linn. It belongs to the family *Apiaceae*. It is mainly cultivated for its leaves as well as seeds. The productivity of Coriander is influenced by several factors such as soil, varieties, fertilizer management, and also various agro techniques used for growing crop. Intensive cultural practices are necessary to produce high yields and quality product. There are numerous factors that influence the nutrition in crops. These factors can be internal or genetic factors on the one hand and external factors on the other hand. Both types play significant roles in the nutrition processes that we can observe in crops. The efficient use of fertilizers is necessary for optimum growth and yield. Hence knowledge about the availability of nutrients in the soil is very essential. Plant analysis serves as an elegant tool for understanding the growth and physiology of the plant at various phases of its growth (Hartz and Hochmuth, 1996). Keeping these facts in view, a pot designed experiment was conducted with to study the effect of different organic manures and fertility levels on growth and nutrient quality of *Coriandrum sativaum* and also to find out the suitable combination of organic manure and fertility levels .



## MATERIALS AND METHODS

The study was conducted at the research lab of Post graduate Research Department of Zoology, Nirmala College Women, Coimbatore during 2020-2021.

### Preparation of Vermicompost

Organic manure was prepared by using *Eudrilus eugenia* species of earthworms with poultry waste and fish waste as substrate at the Organic farm, Rajapalayam, Virudhunagar District. (Plate: 1)

### manure



Plate:1 *Eudrilus eugeniae* –organic

### Scientific Classification of selected earthworm

<b>Kingdom</b>	:	<u>Animalia</u>
<b>Phylum</b>	:	<u>Annelida</u>
<b>Class</b>	:	<u>Clitellata</u>
<b>Subclass</b>	:	<u>Oligochaeta</u>
<b>Order</b>	:	<u>Haplotaxida</u>
<b>Family</b>	:	<u>Eudrilidae</u>
<b>Genus</b>	:	<u><i>Eudrilus</i></u>
<b>Species</b>	:	<i>E. eugeniae</i>



Plate:2 *Eudrilus eugeniae*-Worm

### Collection of Experimental Items

The vermicompost was taken from the earthen pit from Nirmala College for Women. The seeds of *Coriandrum sativum* (Linn.) were collected from Tamilnadu Agricultural University of Coimbatore district. Poultry waste and fish waste was collected from local organic farm, Rajapalayam, Virudhunagar District. All the experimental pots were purchased from Town hall, Coimbatore.





### Scientific Classification of selected plant species

<b>Kingdom</b>	:	Plantae
<b>Order</b>	:	Apiales
<b>Family</b>	:	Apiaceae
<b>Genus</b>	:	<i>Coriandrum</i>
<b>Species</b>	:	<i>C.sativum</i>



**Plate:3** *Coriandrum sativum* Linn.

### Experimental Design

A pot culture study was laid out in completely randomized design with three replications for each treatment. Each pot was uniformly filled with 2 kg of soil and treated with different combinations of Poultry manure and fish manure amended with garden soil. A pot with garden soil without any amendment was maintained for each treatment as control. All the other pots were amended with 25%, 50%, 75% and 100% of poultry manure in one experimental setup and other with 25%, 50%, 75% and 100% of fish manure. The following concentrations are as follows: (T<sub>1</sub>) - Control, (T<sub>2</sub>)- 25%, (T<sub>3</sub>)-50%, (T<sub>4</sub>)- 75%, (T<sub>5</sub>)- 100%

### Treatment Methods

About 30 seeds were sown in each pot and allowed to germinate. There was no incidence of pest or disease on coriander during the experiment. They were then thinned to 15 plants per pot. The pots were watered daily and holes were made at the base of the pot to prevent water logging condition. The plants were observed from germination time till 30<sup>th</sup> day. The plants were uprooted on the 30<sup>th</sup> day without any damage. The adhering soil particles were removed by washing gently with water and the water droplets were removed by blotting with the filter paper. Then these plants were used for the biometric observation and biochemical analysis.

### Prevention of Pest Infection

25gm of garlic was ground, added one liters of water and the mixture was sprayed on to plants to prevent the pest infection.



## Experimental Structure

No. of treatments – 4

No. of replication – 3

Design – CRD (Completely Randomized Design)

No. of pots –15

Period of pot culture – 1 month.

## Biometric observations

The fresh plants were used to determine the fresh weight, shoot length (measured from the point of first cotyledonary node to the tip of the longest leaves), root length (measured from the crown region of the plant to the tip of the root) and number of leaves.

## Morphometric characteristics

- ✚ **Germination of Seeds:** At 30 days after sowing the number of normal seedling germinated were counted and expressed in percentage. The germination percentage was calculated by using the formula outlined by IST (1995).

**Germination percentage= number of seedlings/ total number of seed X100**

- ✚ **Number of leaves per plant:** The total number of leaves of in each of the five randomly selected plants was counted and recorded. The mean number of leaves per plant was worked out.
- ✚ **Leaf Area:** The five tagged plants were also used for leaf area measurement at harvest. The leaf area was measured with the help of leaf area meter. The average leaf area cm<sup>2</sup> was recorded as mean value to calculate total leaf area cm<sup>2</sup> per plant
- ✚ **Height of the plant:** Five plants were randomly selected in each plot and tagged. The plant height was measured at harvest from base of the plant to tip of the main shoot by meter scale and average height of five plants were recorded as mean plant height (cm).
- ✚ **Number of branches per plant:** Total numbers of branches emerging from main stem of the plant were counted in each of the five randomly selected plants and the average was calculated per plant basis.
- ✚ **Length of the root:** The root lengths of the root in each of the five randomly selected plants was measured from the root collar region to the tip of the root using centimeter scale and mean length was expressed in Cm.

## Nutrient Parameters

Determination of available nitrogen was done by alkaline permanganate method suggested by Subbiah and Asija (1956). The estimation of available P was done by using Olsen's extract (0.5 N sodium bicarbonates solution of pH 8.5) as referenced by Olsen *et al.* (1954). It was determined as stannous chloride reduced blue colour the extraction



procedure adopted was as described by Black, (1965) and developing the colour in the extract (Motiramani and Wankhede, 1964) using “UV visible Spectrophotometer”. The available amount of potassium was determined by using normal neutral ammonium acetate Flame photometer (Black, 1965).

### Statistical Analysis

All the data were subjected to mean and standard deviation to identify the difference among the different treatments for different plant parameters in different treatments.

### RESULTS AND DISCUSSION

Plants have played a major role in maintaining human health and civilizing the value of human life for thousands of years (Dhankar *et al.*, 2011). In the last few years, organic food production became very popular trends. Once more, organic farming ensures safe products for human health as well as for the environment due to the fact that the use of chemical fertilizers and pesticides is not allowed. The experimental findings pertaining to the present investigation i.e. comparative effect of poultry manure and fish manure on the growth parameters and NPK of coriander (*Coriandrum sativum* L.). The data on influence of various fertilizers on growth parameters were recorded and statistically analyzed in order to find out the impact of different treatments application. Results with respect to various characters in the study are presented under different heads along with Table (1-13) & Plates 6 & 7 representation respectively.

### Germination

The data presented in Table (1) revealed the effect of different organic manures effect on plant growth parameters of *Coriandrum sativum*. Coriander (*Coriandrum sativum*) seed grown in control (T<sub>1</sub>) garden soil amended without any manure recorded germination percentage as (80.00±1.70% and 66.25±0.78%). In soil amended with 25% poultry manure (T<sub>2</sub>) it showed (88.76 ±0.79 %) of germination, followed by soil amended with 50% (T<sub>3</sub>) as (90.56±1.57 %). In garden soil amended with 75% (T<sub>4</sub>) of poultry manure the germination percentage of *Coriandrum sativum* recorded was (78.33±0.61%) and in 100% (T<sub>5</sub>) it was 52.34 ±0.44% respectively.



**Table: 1 Effect of different concentrations of poultry manure on the germination percentage Of *Coriandrum sativum* after 30<sup>th</sup> day of planting**

Biometric characters	TREATMENTS				
	T <sub>1</sub>	T <sub>2</sub>	T <sub>3</sub>	T <sub>4</sub>	T <sub>5</sub>
Germination (%)	80.00 ±1.70	88.76 ±0.79	90.56 ±1.57	78.33 ±0.61	52.34 ±0.44

\*Each value is the mean ± SD of three replicates.

From Table (2) the germination % recorded in fish manure 25% and 50% potted soil were 71.42±1.37% (T<sub>2</sub>); 78.17±1.27% (T<sub>3</sub>). In treatments pots T<sub>4</sub> (75%) and T<sub>5</sub> (100%), the garden soil amended with fish waste compost recorded germination percentages were (62.51±0.31%) and (43.17±0.10%) respectively.

**Table: 2 Effect of different concentrations of fish manure on the germination percentage of *Coriandrum sativum* after 30<sup>th</sup> day of planting**

Biometric characters	TREATMENTS				
	T <sub>1</sub>	T <sub>2</sub>	T <sub>3</sub>	T <sub>4</sub>	T <sub>5</sub>
Germination (%)	66.25 ±0.78	71.42 ±1.37	78.17 ±1.27	62.51 ±0.31	43.17 ±0.10

\*Each value is the mean ± SD of three replicates.

### Number of leaves

Table (3) revealed the effect of different concentration of poultry manures effect on exomorphological parameter of *Coriandrum sativum*. Among the treatments (T<sub>2</sub> & T<sub>3</sub>) i.e. poultry manure 25% and 50% amended garden soil grown *Coriandrum sativum* showed maximum number of leaves (26.07±4.41; 37.17±6.15) while less number of leaves (14.42±0.87) were recorded in 100% (T<sub>5</sub>). On comparing to control (T<sub>1</sub>) 19.54±5.05 in 75% poultry manure amended soil grown *Coriandrum sativum* recorded minimum number of leaves (16.51±0.31) respectively.

**Table: 3 Effect of different concentrations of poultry manure on the number of leaves in *Coriandrum sativum* after 30<sup>th</sup> day of treatment.**

Biometric characters	TREATMENTS				
	T <sub>1</sub>	T <sub>2</sub>	T <sub>3</sub>	T <sub>4</sub>	T <sub>5</sub>
Number of Leaves	19.54 ±5.05	26.07 ±4.41	37.17 ±6.15	16.51 ±0.31	14.42 ±0.87

\*Each value is the mean ± SD of three replicates.



*Coriandrum sativum* grown in fish manure recorded  $17.34 \pm 3.15$  (T<sub>1</sub>) in garden soil without manure while in 25% and 50% the number of leaves recorded were  $22.17 \pm 3.30$  (T<sub>2</sub>) and  $32.47 \pm 5.03$  (T<sub>3</sub>) after 30<sup>th</sup> day of planting. The minimum numbers of leaves recorded after 30<sup>th</sup> day of transplantation were  $14.76 \pm 0.51$  (T<sub>4</sub>) and  $12.66 \pm 0.37$  (T<sub>5</sub>) in 75% and 100% on comparing to the control pot ( $17.34 \pm 3.15$ ) grown *Coriandrum sativum* Table (4) respectively.

**Table: 4 Effect of different concentrations of fish manure on the number of leaves in *Coriandrum sativum* after 30<sup>th</sup> day of planting.**

Biometric characters	TREATMENTS				
	T <sub>1</sub>	T <sub>2</sub>	T <sub>3</sub>	T <sub>4</sub>	T <sub>5</sub>
Number of Leaves	17.34 $\pm 3.15$	22.17 $\pm 3.30$	32.47 $\pm 5.03$	14.76 $\pm 0.51$	12.66 $\pm 0.37$

\*Each value is the mean  $\pm$  SD of three replicates.

#### Leaf Area

From Table (5-6) the data of biometric character (leaf area) of selected herb *Coriandrum sativum* (Linn.). From the above data it is observed that the *Coriandrum sativum* (Linn.) grown in 50% (T<sub>3</sub>) poultry manure amended soil shown greater leaf area  $14.58 \pm 2.55$  Cm when compared to 50% (T<sub>3</sub>) fish manure amended soil grown *Coriandrum sativum*  $12.03 \pm 2.13$  Cm . In the present observation when comparing with the control grown experimental plant *Coriandrum sativum* ( $10.43 \pm 2.11$  Cm;  $8.00 \pm 0.99$ ) the 100% poultry manure and fish manure soil grown *Coriandrum sativum* recorded minimum  $8.23 \pm 2.09$  Cm and  $5.38 \pm 1.38$  Cm leaf area .

**Table: 5 Effect of different concentrations of poultry manure on the leaf area of *Coriandrum sativum* after 30<sup>th</sup> day of planting.**

Biometric characters	TREATMENTS				
	T <sub>1</sub>	T <sub>2</sub>	T <sub>3</sub>	T <sub>4</sub>	T <sub>5</sub>
Leaf Area (Cm)	10.43 $\pm 2.11$	10.63 $\pm 2.38$	14.58 $\pm 2.55$	9.27 $\pm 2.23$	8.23 $\pm 2.09$

\*Each value is the mean  $\pm$  SD of three replicates.





**Table: 6 Effect of different concentrations of fish manure on the leaf area of *Coriandrum sativum* after 30<sup>th</sup> day of planting.**

Biometric characters	TREATMENTS				
	T <sub>1</sub>	T <sub>2</sub>	T <sub>3</sub>	T <sub>4</sub>	T <sub>5</sub>
Leaf Area (Cm)	8.00 ±0.99	10.30 ±1.43	12.03 ±2.13	7.60 ±2.01	5.83 ±1.38

\*Each value is the mean ± SD of three replicates.

Next to control grown pot the herb *Coriandrum sativum* (Linn.) grown 75% poultry manure (T<sub>4</sub>) amended soil pot showed moderate leaf area (9.27 ±2.23Cm). Among the selected treatments fish waste compost (T<sub>4</sub>) by *Eudrilus euginea* amended soil grow *Coriandrum sativum* (Linn.) showed least leaf length (7.60±2.01Cm) respectively after 30<sup>th</sup> day of planting.

#### Plant height

The prime exomorphological character plant height (mm) of selected herb *Coriandrum sativum* are presented in Table (7 -8). It is observed that the *Coriandrum sativum* (Linn.) grown in poultry manure amended soil (T<sub>3</sub>) 50% shown greater plant height (75.50 ± 1.22 mm) followed by (T<sub>2</sub>) 50% (69.50 ± 2.62 mm). Minimum height was observed in (T<sub>4</sub>) 75% (63.91±1.17) when compared to the control (T<sub>1</sub>) (67.70±1.75mm) pot grown plant not amended with manure. Among the treatment of selected concentrations, soil amended with 100% (T<sub>5</sub>) poultry manure recorded the least plant height (56.50±2.03mm) respectively.

**Table: 7 Effect of different concentrations of poultry manure on the plant height of *Coriandrum sativum* after 30<sup>th</sup> day of planting.**

Biometric characters	TREATMENTS				
	T <sub>1</sub>	T <sub>2</sub>	T <sub>3</sub>	T <sub>4</sub>	T <sub>5</sub>
Plant Height (mm)	67.70 ±1.75	69.50 ±2.62	75.50 ±1.22	63.91 ±1.17	56.50 ±2.03

\*Each value is the mean ± SD of three replicates.



**Table: 8 Effect of different concentrations of fish manure on the plant height of *Coriandrum sativum* after 30<sup>th</sup> day of planting**

Biometric characters	TREATMENTS				
	T <sub>1</sub>	T <sub>2</sub>	T <sub>3</sub>	T <sub>4</sub>	T <sub>5</sub>
Plant Height (Cm)	27.98 ±6.47	29.78 ±5.75	31.42 ±6.62	22.12 ±4.69	18.67 ±4.47

\*Each value is the mean ± SD of three replicates.

In the treatment pot amended with fish manure the selected experimental plant *Coriandrum sativum* (Linn.) showed the maximum plant height ( $31.2 \pm 6.62$  mm) in potted soil amended with 50% (T<sub>3</sub>) fish manure. On the other hand *Coriandrum sativum* grown in only garden soil (ie) control (T<sub>1</sub>) recorded ( $27.98 \pm 6.47$  mm). Among the selected treatments fish waste compost of 75% and 100% (T<sub>4</sub> & T<sub>5</sub>) amended soil grown *Coriandrum sativum* (Linn) showed minimum plant height ( $22.12 \pm 4.69$  mm) and ( $18.67 \pm 4.47$  mm) respectively Table 8. The herb *Coriandrum sativum* (Linn.) grown in pot soil amended with 25% fish manure showed maximum plant height ( $29.78 \pm 5.75$  mm) next to 50% grown herb respectively.

### Number of branches

**Table: 9 Effect of different concentrations of poultry manure on the number of branches in *Coriandrum sativum* after 30<sup>th</sup> day of planting.**

Biometric characters	TREATMENTS				
	T <sub>1</sub>	T <sub>2</sub>	T <sub>3</sub>	T <sub>4</sub>	T <sub>5</sub>
No of Branches	12.28 ±1.10	12.62 ±0.55	13.12 ±2.39	12.20 ±1.35	9.91 ±2.57

\*Each value is the mean ± SD of three replicates.

Table (9) shows the data of biometric character (number of branches) of selected herb *Coriandrum sativum* (Linn.). From the above data it is observed that the *Coriandrum sativum* (Linn.) grown in poultry manure amended soil shown greater number of branches ( $12.62 \pm 0.55$  ;  $13.12 \pm 2.39$ ) in pots amended with 25% and 50% of manures. Next to T<sub>2</sub> and T<sub>3</sub> amended soil grown herb *Coriandrum sativum* (Linn.) the T<sub>4</sub> (75%) amended soil grown plant showed maximum number of branches ( $12.20 \pm 1.35$ ) which was followed by 100% manure amended grown *Coriandrum sativum* ( $9.91 \pm 2.57$ ).



**Table: 10 Effect of different concentrations of fish manure on the number of branches in *Coriandrum sativum* after 30<sup>th</sup> day of planting.**

Biometric characters	TREATMENTS				
	T <sub>1</sub>	T <sub>2</sub>	T <sub>3</sub>	T <sub>4</sub>	T <sub>5</sub>
No of Branches	6.24 ±0.93	6.85 ±0.85	8.41 ±0.58	6.00 ±1.24	5.32 ±0.47

\*Each value is the mean ± SD of three replicates.

The fish waste compost composed by *Eudrilus euginea* amended soil grow *Coriandrum sativum* (Linn.) showed least number of branches (5.32 ± 0.47) and (6.00 ± 1.24) i.e. T<sub>5</sub> & T<sub>4</sub> concentrations grown plant after 30<sup>th</sup> day after planting. Comparing to the following selected treatments the experimental plant grown in garden soil amended pot i.e. Control (T<sub>1</sub>) showed minimum number of branches (6.24 ± 0.41) than other manure concentration treated pot. The maximum number of branches 6.85±0.85 (T<sub>2</sub>) and 8.41±0.58 (T<sub>3</sub>) was recorded in 25% and 50% fish manure amended garden soil grown *Coriandrum sativum* (Linn.) respectively.

### Root length

Data presented in Table (11 & 12) show that the effect of different treatments 25%-100% influenced significantly on root length. From the data mean comparison (Table 11) shows that the best treatment for increasing the root length (T<sub>2</sub>) 25% and (T<sub>3</sub>) 50% i.e. poultry (19.91±1.90mm; 26.30±1.98mm) and fish manure (Table 12) (17.09±1.10mm; 22.11±1.58mm) amended pot grown *Coriandrum sativum* which showed maximum root length.

**Table: 11 Effect of different concentration of poultry manures on the root length in *Coriandrum sativum* after 30<sup>th</sup> day of planting.**

Biometric characters	TREATMENTS				
	T <sub>1</sub>	T <sub>2</sub>	T <sub>3</sub>	T <sub>4</sub>	T <sub>5</sub>
Root length (mm)	14.01 ±0.26	19.91 ±1.90	26.30 ±1.98	11.52 ±1.23	9.01 ±0.16

\*Each value is the mean ± SD of three replicates.

A perusal of Table (11) and also revealed that the root length of seedling of Coriander (*Coriandrum sativum*) was found to be (14.01±0.26mm; 11.45±0.16mm) in control soil (T<sub>1</sub>). The herb *Coriandrum sativum* grown in poultry manure (T<sub>4</sub>) amended soil recorded



(11.52±1.23 mm) root length and (9.55±1.13 mm) in fish manure (T<sub>4</sub>) amended soil. Whereas plant grown in 100% poultry manure and fish manure amended soil was noted to be (9.01±0.16mm) and (6.32 ± 0.15mm) root length after 30<sup>th</sup> day of planting. On the other hand coriander plant grown in fish waste (T<sub>5</sub>) compost recorded (6.32±0.15 mm) root length while the root length (9.01±0.16mm) grown in poultry waste compost amended garden soil respectively.

**Table: 12 Effect of different concentration of fish manures on the root length in *Coriandrum sativum* after 30<sup>th</sup> day of planting.**

Biometric characters	TREATMENTS				
	T <sub>1</sub>	T <sub>2</sub>	T <sub>3</sub>	T <sub>4</sub>	T <sub>5</sub>
Root length (mm)	11.45 ±0.16	17.09 ±1.10	22.11 ±1.58	9.55 ±1.13	6.32 ±0.15

\*Each value is the mean ± SD of three replicates.

### Nutrient Parameters

Soil nutrient management is necessary to maintain the constant productivity as well as good quality soil. Animal manure is a valuable resource as a soil fertilizer because it provides large amounts of macro and micronutrients for crop growth and is available at low-cost. In addition these manures are environmentally-friendly and alternative to mineral fertilizers.

In the present study the maximum nitrogen recorded was 2.9±1.18 % and 2.0 ±1.14 (%) in T<sub>3</sub> concentration i.e 50% of the poultry manure and fish manure amended pot grown *Coriandrum sativum* while the minimum percentage of 0.9 ±0.16 % and 0.3±0.13 % was noted in T<sub>5</sub> treatment 100% poultry and fish manure amended potted plants. Similarly the macro nutrients like phosphate 11.3±0.21%; 10.5±0.05% and potassium 5.4±0.25% and 3.15±0.22% too was recorded high in T<sub>3</sub> followed by T<sub>2</sub> concentration grown garden soil amended with poultry and fish manure after 30<sup>th</sup> day of planting.

**Table: 13 Effect of different concentration of poultry manures on the NPK content in *Coriandrum sativum* after 30<sup>th</sup> day of planting.**

Nutrient parameter	TREATMENTS				
	T <sub>1</sub>	T <sub>2</sub>	T <sub>3</sub>	T <sub>4</sub>	T <sub>5</sub>
Nitrogen (%)	1.5 ±0.2	2.1 ±0.10	2.9 ±1.18	1.2 ±1.23	0.9 ±0.16
Phosphate (%)	9.2 ±0.11	10.9 ±0.19	11.3 ±0.21	8.9 ±0.44	7.8 ±0.58
Potassium (%)	3.5 ±0.77	4.0 ±0.52	5.4 ±0.25	2.8 ±0.63	1.7 ±0.72

\*Each value is the mean ± SD of three replicates.



**Table: 14 Effect of different concentration of fish manures on the NPK content in *Coriandrum sativum* after 30<sup>th</sup> day of planting.**

Nutrient parameter	TREATMENTS				
	T <sub>1</sub>	T <sub>2</sub>	T <sub>3</sub>	T <sub>4</sub>	T <sub>5</sub>
Nitrogen (%)	1.0 ±0.3	1.6 ±0.9	2.0 ±1.14	0.9 ±1.26	0.3 ±0.13
Phosphate (%)	8.4 ±0.11	9.8 ±0.01	10.5 ±0.05	7.9 ±0.12	6.3 ±0.19
Potassium (%)	2.67 ±0.07	2.89 ±0.13	3.15 ±0.22	2.49 ±0.43	2.35 ±0.37

\*Each value is the mean ± SD of three replicates.

On comparing with Control plant (T<sub>1</sub>) 1.5±0.2; 9.2±0.11; 3.5±0.77 of NPK levels T<sub>4</sub> (75%) treated *Coriandrum sativum* herb after 30<sup>th</sup> day of planting recorded less amount of NPK 1.23±1.23; 8.9±0.44; 2.8±0.63 in poultry waste treated potted plant. In fish manure treated plant the NPK levels T<sub>4</sub> (75%) treated *Coriandrum sativum* herb after 30<sup>th</sup> day of planting recorded were 0.96±1.26; 7.9±0.12 and 2.49±0.43 which was noted to be less than control (T<sub>1</sub>) plant 1.0±0.3; 8.4±0.11 and 2.67±0.07 respectively.

50.9 million hectare under organic culture and 2.4 million producers working in this sector. 12.7 million hectare land under organic agriculture in Asia. The share of world's organic agricultural land is 1.1 percent. Country with most organic agriculture producers are India (5, 85,200). Asia has 4<sup>th</sup> rank with 4 million hectare land that comprises 8% of world's organic agricultural land. India has 9<sup>th</sup> rank in organic agriculture land in the world. India has 1<sup>st</sup> position as producer of organic products worldwide

From the above experimental results it authentically proves that the organic manures like poultry manure and fish manure is considered to be the best, active and cheapest source of plant nutrients which could be considered as efficient manure that helps in maintaining soil fertility. Soil, the soul of infinite lives that promotes diverse micro flora primarily holds earthworms, the “farmer’s friend” or “nature’s ploughman”. It influences the physical and chemical properties of soil.

Thus from the present study results the data revealed that increase in plant growth, i.e. germination percentage, plant height, leaf area, branches number, leaf number and root length





could probably be due to improvement in the physicochemical properties of soil; increase in enzymatic activity; increase in microbial population, diversity and activity; easy availability of macro and micronutrients; and also increase in plant growth hormones by application of poultry manure and fish manure. According to Stephen Oyedeji *et al.*, 2014 Organic fertilizer ie poultry manure (PM) generally increased the growth of all the plant species. The significant increase in the mean values of selected exomorphological parameter was observed in poultry grown ( $T_3$  &  $T_2$ ) *Coriandrum sativum* when compared to control ( $T_1$ ) which was similar to the results obtained Ayeni *et al.*, 2012 who stated that poultry manure also contains useful soil nutrients that are needed for the growth of plants but their composition is in the crude form that is released slowly to the soil

The increase in leaf area, root length, number of leaves and branches in poultry amended soil grow *Coriandrum sativum* may be due to soluble bacteria which are present in it which may generate soil soluble phosphorus, secretion of plant growth hormones, natural enzymes, antibiotics and different essential compounds which are capable to develop the aerial parts of plant. This statement was supported by Astarai and Koocheki, 1997 who stated that application of biological fertilizer will help to sustain agriculture. Poultry manure has traditionally been treated as a waste product and applied to surrounding crop and pasturelands to recycle nutrients, primarily nitrogen (N), phosphorus (P), and potash (K) (Lorimor and Xin, 1999). Therefore, the number of leaves and leaf area may not behave in association however, they can follow similar trend partially due to variations in the individual growth of leaf laminae. In the present study, it is observed that though not very strong there are an association between the number of leaves and leaf area i.e. more the leaves in a genotype maximum is the leaf area per plant or at least on par with the most superior accession. The observations recorded by Banerjee and Kole (2004) and Mourya *et al.* (2015) in fenugreek for grain yield per plant were also in conformity with this

Poultry manure is often applied to meet the crop nitrogen requirement, resulting in excessive P application. While the agronomic benefits are well established, the environmental aspects of poultry manure management have primarily focused on water quality (Harmel *et al.*, 2009; Vervoort *et al.*, 1998). A more comprehensive assessment of poultry manure usage in agro-ecosystems considers crop yield, soil health, and water quality, as well as the economic impact of integrating poultry manure into cropping systems. Economic factors are



of paramount importance as they are a primary, if not the leading factor driving farm-scale decision-making.

The biometric parameters recorded from the experimental plant with fish waste fertilizer is as comparable to the results of Lazcano et al., 2008. The fermented fish waste was found to be biological preparations as sufficient source of micronutrients and microorganisms. It has beneficial microbes for the growth of *Coriandrum sativum* which has promoted the plant growth via root length and nodulation when compared with fish wastes which was similar to the findings of Hoover et al., 2015. Moreover processing of this fish waste material through controlled bio-oxidation processes, such as composting, reduces the environmental risk by transforming the material into a safer and more stable product suitable for application to soil (Lazcano *et al.*, 2008), and also reduces the transportation costs because of the significant reduction in the water content of the raw organic matter. Application of unstable or immature compost may inhibit seed germination, reduce plant growth and damage crops by competing for oxygen or causing phytotoxicity to plants due to insufficient biodegradation of organic matter (Wu *et al.*, 2000; Brewer and Sullivan, 2003 and Cooperband *et al.*, 2003).

Plants with higher yield remove high N, P and K from the soil. A positive relationship was observed between uptake of the major nutrients and yield, probably through better uptake of N, P and K and their utilization in protein synthesis. In the present study the plant in T<sub>3</sub> which recorded maximum number of leaves, branches, larger; leaf area, height and root length recoded higher concentration of nitrogen 2.9±1.18 % and 2.0 ±1.14 ; phosphate 11.3±0.21%; 10.5±0.05% and potassium 5.4±0.25% and 3.15±0.22%. Deora and Singh, (2008) revealed that the application of fertilizer significantly increased the N, P, K contents and there uptake by crop. Channabasavanna, (2002), Salem and Awad, (2005); Tripathi, (2006) observed similar result.

Poultry manure is an organic fertilizer source that benefits yield, soil health, and overall farm income, and thus can be viewed as a regionally marketable resource (Janzen *et al.*, 1999). Organic manure increased soil pH, the concentrations of nitrogen, phosphorus, and major cations. Potassium (K) is the second most important nutrient element next to nitrogen for growth and development of spices crops. Plant absorbs potassium in its ionic form, K<sup>+</sup>. Potassium is an essential nutrient for proper growth, root development and seed and fruit



development and reproduction of plant. It affects the plant size, shape, colour, taste and other measurement attributed to healthy production. Potassium promotes increased root growth and thicker cell walls. After N, P is the second most frequently limiting macronutrient for plant growth. Phosphate is mostly presence in soil which is uptake by plant using specific transporter present in a cell membrane. Phosphate is an important macronutrient in a plant making up about 0.2% of a plants dry weight. It is a component key of nucleic acids, carbohydrate, phospholipids, ATP. Plants cannot grow without a reliable supply of the nutrient. Phosphate is one 17 nutrients essential for plant growth. Gascho and Hubbard, (2006) reported increased soil phosphate in sandy soils after seven years of broiler manure application. Major cations, including potassium, and nitrogen and phosphorus were increased by organic manure treatment due to their high content in organic manure. Application of animal waste manures, which contain both mineral and organic nitrogen, is useful for maintaining and improving soil fertility and rice production (Takahashi, Uenosono, and Nagatomo 2004). The plant accumulations of P and K were significantly different between the soils and among treatments in both years (Table 5). Significantly greater plant accumulation of P and K were observed in poultry manure than fish manure application.

## CONCLUSION

Organic manures provide a stable organic matter that improves the physical, chemical, and biological properties of soils, thereby enhancing soil quality and crop production. When correctly applied, the organic manures will have beneficial effects on soil properties, thus creating suitable conditions for root development and consequently promoting higher yield and higher quality of crops. One of the unique features of organic manure is that during the process of conversion of various organic wastes by earthworms, many of the nutrients are changed to their available forms in order to make them easily utilizable by plants. Therefore, organic manures have higher level of available nutrients like nitrate or ammonium nitrogen, exchangeable phosphorous and soluble potassium, calcium and magnesium derived from the wastes (Buchanan *et al.*, 1988).The significant increase in all growth parameters in poultry manure treated potted plants than fish manure may be due to the significant increase in the absorption of major plant nutrients such as N, P and K by plants. This clearly indicates that poultry manure is highly suitable than fish manure for quick absorption of the major nutrients and provides enhanced nourishment for plants. Thus, the



present results clearly suggest that poultry manure and fish manure can be employed in sustainable farming practices and farmers are request to avoid using chemical fertilizers which reduces or even eradicates the beneficial nutrients and a microorganism present in the soil and reduces the nutrient availability necessary for plant growth.

## BIBLIOGRAPHY

1. Astaraei, A. and A. Koocheki, (1997). *Application of biological fertilizers in Sustainable agriculture. Mashhad Jihad. Daneshgahi Press. First Edition. (Translate).*
2. Ayeni, L. S., E. O. Adeleye, and J. O. Adejumo. (2012). *Comparative effect of organic, organo-mineral and mineral fertilizers on soil properties, nutrient uptake, growth and yield of maize (Zea mays), International Research Journal of Agricultural Science and Soil Science, 2(11):493–497.*
3. Banerjee, P.C. Kole. (2004). *Analysis of genetic divergence in fenugreek (Trigonella foenum-graecum L. J. Spices Aromat. Crops, 13: 49-51.*
4. Black, C.A. (1965). *Method of plant and soil analysis part-II pub Amer. Sco. Agron. Madison, Wisconsin, USA. PP.1367-1373.*
5. Brewer, L.J., Sullivan, D.M., (2003). *Maturity and stability evaluation of composted yard trimmings. Compost Science and Utilization, 11 (2): 96–112.*
6. Buchanan MA, Russelli E, Block SD (1988). *Chemical characterization and nitrogen mineralization potentials of vermicomposts derived from differing organic wastes, in Earthworms in Environmental and waste Management, (eds C. A. Edwards and E. F. Neuhauser), SPB Acad, Publ., The Netherlands, pp. 231-9.*
7. Channabasavanna, A.S. (2002). *Standardization and economic analysis of fertilizer levels for coriander (Coriandrum sativumL.). J. Maharashtra Agril. Univer., 27(2): 160-162.*
8. Cooperband, L.R., Stone, A.G., Fryda, M.R., Ravet, J.L., (2003). *Relating compost measures of stability and maturity to plant growth. Compost Science & Utilization 11 (2): 113–124.*
9. Deora, N.S. and Singh, J. (2008). *Effect of integrated nutrient management and seed rate on quality of fenugreek (Trigonella corniculata L.) cv. Kasuri and post-harvest soil fertility status in loamy sand soil of Rajasthan. Environ. & Ecol., 26(4A): 1749-1752.*
10. Dhankar, S. Kaur, R. Ruhil, S. Balhara, M. Dhankhar, S. Chhillar, A.K. (2011). *A review on Justicia adhatoda a potential source of natural medicine. African Journal of Plant Science, 620-627.*
11. Gascho.G.J., R.K. Hubbard. (2006). *Long-term impact of broiler litter on chemical properties of a Coastal Plain soil. J. Soil Water Conserv., 61 (2): L65-L74.*
12. Grubinger, Vernon P. (1999). *Sustainable vegetable production from start-up to market. Ithaca, N.Y.: Natural Resource, Agriculture, and Engineering Service, Cooperative Extension. Natural Resource, Agriculture, and Engineering Service (NRAES) . Book Chapter.*
13. Harmel. R.D., D.R. Smith, R.L. Haney, M. Dozier. (2009). *Nitrogen and phosphorus runoff from cropland and pasture fields fertilized with poultry litter. J. Soil Water Conserv., 64 (6): 400-412.*
14. Hartz, T.K. and Hochmuth, G.J. (1996). *Fertility management of drip irrigated vegetables. Hort. Tech., 6:168.*
15. Hoover, N.L., R. Kanwar, M.L. Soupir, C. Pederson. (2015). *Effects of poultry manure application on phosphorus in soil and tile drain water under a corn-soybean rotation. Water Air Soil Pollut., 226:138.*
16. Janzen. R.A., W.B. McGill, J.J. Leonard, S.R. Jeffrey. (1999). *Manure as a resource – ecological and economic consideration in balance Trans. ASAE (Am. Soc. Agric. Eng.), 42: 1261-1273.*
17. Lazcano, C., Gómez-Brandón, M. and Domínguez, J. (2008). *Comparison of the effectiveness of composting and vermicomposting for the biological stabilization of cattle manure. Chemosphere, 72: 1013-1019*
18. Lorimor. J. C., H. Xin. (1999). *Manure production and nutrient concentrations from highrise layer house. Applied Engineering in Agriculture, 15(4): 337-340.*
19. Motiramani, S.A. and Wankhede, P.K. (1964). *Soil nutrients bio-variability a mechanist approach. John Wiley and Sons, Bombay, (M.S.) India.*
20. Mourya, P.B, Yadav, K.B, Pandey, P.V. and Yadav S.P. (2015). *Correlation and path analysis in Fenugreek (Trigonella foenum-graecum L.). Research of Environmental Life Science. 8(4): 569-70.*
21. Olsen, S.R., Cale, C.V., Watonable, F.S. and Dean, L.A. (1954). *Estimation of available phosphorus in soil by extraction with sodium bicarbonate. Circular No. 939 – Washington.*



22. Salem, A.G. and Awad, A.M. (2005). Response of coriander plants to organic and mineral fertilizers fustigated in sandy soils. *Egyptian J. Agril. Res.*, 83(2): 829-858.
23. Stephen Oyedeji, David Adedayo Animasaun, Abdullahi Ajibola Bello, and Oludare Oladipo Agboola.(2014). Effect of NPK and poultry manure on growth, yield, and proximate composition of three amaranths. <https://doi.org/10.1155/2014/828750>.
24. Subbian, B.V. and Asija, G.L. (1956). A rapid procedure for estimation of available nitrogen in soils. *Curr.sci.*, 25: 259-260.
25. Takahashi, S., S. Uenosono, and M. Nagatomo. (2004). Rice uptake of nitrogen form aerobically and anaerobically composted poultry manure. *Journal of Plant Nutrition* 27:731–741
26. Tripathi, M.L. (2006). Effect of potassium and sulphur levels on yield and uptake of N, P and K by coriander. *Crop Res. (Hisar)*, 32 (3): 370-371.
27. Vervoort. R.W., D.E. Radcliffe, M.L. Cabrera, M. Latimore, Jr. Field. (1998). Scale nitrogen and phosphorus losses from hayfields receiving fresh and composted broiler litter. *J. Environ. Qual.*, 27 (5): 1246-1254.
28. Wu, L., L.Q. Ma and G.A. Martinez. (2000). Comparison of methods for evaluating stability and maturity of biosolids compost. *J. Environ. Qual.*, 29: 424-429.





## A STUDY ON CONSUMER BUYING BEHAVIOUR TOWARDS SMARTPHONES WITH SPECIAL REFERENCE TO TIRUPUR CITY

<sup>1</sup>Mr. S. MURUGANANTHAM, <sup>2</sup>Mr. S. NAVEEN

<sup>1</sup>Assistant Professor, Department of Commerce with Professional Accounting,  
Dr.N.G.P. Arts and Science College, Coimbatore

<sup>2</sup>181PA036, Department of Commerce with Professional Accounting,  
Dr.N.G.P. Arts and Science College, Coimbatore

### ABSTRACT

*As a result, the market of smartphones has been escalating every year with increasing innovation. In third quarter of 2012 the number of smartphones use totaled 1.03 billion, a 47% increase from third quarter 2011. India is one of the fastest growing economies all over the world. It is true that hi tech technology has played a vital role in attracting the people towards smartphones. There are variety of smartphones with different names and brands available in the market such as apples, one plus, vivo, Samsung, etc. Brand is another factor that drives people to buy smartphones. The Tools like Percentage Analysis and Rank analysis were used for the study. The major purpose of this study is to analyze consumer behavior towards smartphones in the Tirupur city by finding the factors which influence consumer in their smartphones purchases*

**KEYWORDS:** Consumer behaviour, Smartphones, hi tech technology

### 1. INTRODUCTION

The rapidly growing of demand of smartphones has created a buzz around the world. Now a day's most of the consumers opt to have a smartphones. The increasing innovation in mobile phones industries has brought this craze among the people on Smartphones. Smartphones is configured by an operating system with advanced computing capability and connectivity. Generally, Smartphones has high sensor big touch screens and high pixel cameras with lots of features and applications. Mostly listening Music, Reading news, games, finance, health and fitness, taking notes, calendar, weather forecast and lots of other things. These features and application in smartphones somehow have made people's life easier either in daily life, at work or for entertainment purposes

### 2. STATEMENT OF THE PROBLEM

Mobile phone has now become the basic need of every person in their life. Understanding of brand preference is essential aspects as it reflects the

customer choice, purchase of particular brand, performance, style and satisfaction of the customer. Along with the smartphones fundamental capabilities to make voice call, video call, and SMS and MMS, smartphones have been repositioned as new information medium.

As number of manufacturer has entered the smartphones market the competition in smartphones market becomes more and more fierce Nokia a smartphone manufacturer used to dominant the phone market but recently it appears to be losing ground in smartphones market. People now are living in the highly developed and technologically advance society. The Tiruppur city has tremendous potential for all the products and services because people of various religion, language, cultural, background and demographic and socio-economic characteristic live in this area.



### 3. OBJECTIVE OF THE STUDY

- To study the socio-economic characteristics of smartphones in Tirupur city.
- To identify the factors to be considered while purchasing smartphones in Tirupur city.

- To analyze the awareness level towards the smartphones in Tirupur city.
- To study the consumer buying behaviour of a branded smartphones in Tirupur city.

### 4. RESEARCH METHODOLOGY

Sampling technique	Convenient Sampling technique
Area of the Study	Tirupur City
Sampling size	88 Respondents

### 5. STATISTICAL TOOLS

The following statistical tools were applied to analyse the statistical data

- Percentage Analysis.
- Rank Analysis.

### 6. REVIEW OF LITERATURE

**Dr.Abdul Ghafoor Awan and Ms. Arooj Fatima(2014)** This study included both male and female respondents to show that how marketing strategies used by marketers in terms of service quality, pricing, value offered, trust and switching cost affects the purchasing behaviour. Youth is considered as the largest and important segment of customers which cannot be ignored by cellular companies if they want to increase their profits.

**S. Namasivayam, M. Prakash and M. Krishnakumar (2014)**, "A Study on Customer Satisfaction Towards Samsung Smart Phones With Reference to Coimbatore City", Customer

Satisfaction should be the main aim of a business. It is essential for businesses to effectively manage customer satisfaction. The researcher has conducted this study to find out the level of customer satisfaction towards Samsung smart phones. The target respondent includes those customers who are using the Samsung smart phones. The collected data was edited, coded and tabulated by using some statistical tools.

**Mesay Sata( 2013)** This study suggested that the mobile phone sellers should consider the above mentioned factors to equate the opportunity. The objective of this research was to investigate the underlying factors that determine the decision to purchase mobile phone devices. According to the study, majority of the consumers own Nokia mobile phones. Moreover, most of Nokia mobile phone users have a plan to shift to other brands such as Samsung, Apple and BlackBerry.

### 7. TABLE

PERCENTAGE ANALYSIS  
 HOW OFTEN CHANGE YOUR SMARTPHONES

S.NO	USING SMARTPHONE	NO OF RESPONDENTS	PERCENTAGE(%)
1	Less than 1 year	20	23
2	1 year – 2 Year	23	26
3	2 year – 4 Year	32	36
4	More than 4 years	13	15
	<b>Total</b>	<b>88</b>	<b>100</b>

Source: primary data

### INTERPRETATION

The above table indicates that out of the total respondents taken for the study, 23% of the respondents are often change the smartphones Less than one year, 26% of the respondents are often change the smartphones Between One year to Two year, 36% of the respondents are often change the

smartphones between two year to four year and 15% of the respondents are often change the smartphones More than four year .

### INFERENCE

**Most (36%) of the respondents are Often change the smartphone between two year to four year**



**RANK ANALYSIS  
 LEVEL OF AWARENESS TOWARDS MOBILE BRANDS**

BRANDS	Value	5	4	3	2	1	TOTAL	RANK
Samsung	No	10	35	12	10	16	262	4
	Score	50	140	36	20	16		
Apple	No	22	30	14	10	12	304	3
	Score	110	120	42	20	12		
Vivo	No	35	12	33	04	04	334	2
	Score	175	48	99	08	04		
Redmi	No	45	10	20	10	03	348	1
	Score	225	40	60	20	03		
Oneplus	No	12	29	28	12	07	291	5
	Score	60	116	84	24	07		

Source: primary data

**INTERPRETATION**

The above table indicates that, out of those respondents taken for the study, the respondents have given top priority to the Redmi Smart phone Brand, followed by Brand like to Samsung, Apple, Vivo and One plus

**INFERENCE**

**It is concluded that the respondents have given top priority to the Redmi Smart phone.**

**8. SUGGESTIONS**

- To explore the market, mobile industry have to concentrate more on youth segment by giving more advanced features.
- The mobile sellers should take necessary measures to increase the number of service center in rural areas and try to offer free service for rural people.
- More offers and discounts should be used as a weapon to attract customers
- As consumer wants more and more features so smart phone manufacturers should increase of the number of features.

**9. CONCLUSION**

Since then, there has been many large mobile phone companies ‘stepping their foot’ into the industry. Due to the large entry of mobile phone

companies, many smartphone brand has introduced to the market in India, namely Apple, Samsung, Sony, Lenovo, HTC, Huawei, LG, Motorola, Asus, Nokia, Blackberry, Oppo, Ninethology, and Xioami. Usually, they use it in home, school, work, bus, train, coffee shop, restaurants, cinema, supermarket, shopping malls, waiting time, café, walking, gym and parks. Obviously, Smartphone have changed the ways that we used to live, communicate and connect with people all over the world. The major purpose of this study is to analyze consumer behavior towards smartphones in the Tirupur city by finding the factors which influence consumer in their smartphones purchases

**10. REFERENCE**

1. S L Gupta, Sumitra Pal (2013) “Consumer Behavior an Indian Perspective Text and Cases”.
2. Del, L Hawkins (2015) “Consumer Behavior Building Marketing Strategy”.
3. K K Srivastava, Sujata khandai (2011) “Consumer Behavior in Indian Context”.
4. A.Mohankumar, U.Dineshkumar. Study the “Customer Purchase Behaviour towards Mobile Phone With Special Reference To Erode City” IOSR Journal of Business and Management (IOSR-JBM)
5. K.PRABHA KUMAR Study “BUYING BEHAVIOR IN SELECTING MOBILE PHONES



WITH REFERENCE TO TIRUPUR CITY”  
International journal for innovative research in  
multidisciplinary field issn: 2455-0620  
volume - 3, issue - 11, nov – 2017

6. Dr.T.N.R.KAVITHA , K.YOGESWARI Study  
“Customer Attitude Towards Smartphones With  
Special References To Chithode, Erode District”  
OSR Journal of Business and Management  
(IOSR-JBM) e-ISSN : 2278-487X, p-ISSN : 2319-  
7668, PP 33-36
7. J.Sathya and.K.Varunapriya Study “customers’  
preference and satisfaction towards android  
mobiles with reference to Coimbatore city of  
India” International Journal of Interdisciplinary  
and Multidisciplinary Studies (IJIMS), 2015, Vol  
2, No.5, 83-85 ISSN: 2348 – 0343
8. P.Jimpaul Joshual M.Com CA,  
S.Karpagalakshmi. Study On “CONSUMER  
SATISFACTION AND PREFERENCES  
TOWARDS SMARTPHONES, AT  
SARAVANAMPATTI, IN COIMBATORE” SJIF  
Impact Factor: 6.260/ ISI I.F.Value:1.241  
Volume: 4 | Issue: 10 | October | 2019 ISSN:  
2455-7838(Online) EPRA International  
Journal of Research and Development (IJRD)
9. B.Ismail Zabiullah, B.Eswar Sai, B.Amarendra  
Analysis “Buying behaviour of customers  
towards Smartphone’s”

## WEBSITES

1. [www.iosrjournals.org](http://www.iosrjournals.org)
2. [WWW.IJIRMF.COM](http://WWW.IJIRMF.COM)
3. [www.ijims.com](http://www.ijims.com)
4. <https://pdfs.semanticscholar.org/>
5. <https://www.researchgate.net/publication/326488826/>
6. <https://www.ictactjournal.in/>
7. <https://www.slideshare.net/Mobile/>



# NOBEL PRIZE IN CHEMISTRY, 2020: THOUGHTS AND IMPLICATIONS

**Agnita Kundu\***

*Assistant Professor, Department of Chemistry, Shri Shikshayatan College, Kolkata. West Bengal, India*

**Corresponding Author: Dr. Agnita Kundu.**

**Article DOI:** <https://doi.org/10.36713/epra7399>

**DOI No:** 10.36713/epra7399

## ABSTRACT

*Nobel Prize is considered to be the most prestigious prize in the world of academics. Its influence is felt even in non-academic world. This year the Nobel prize in Chemistry was shared by Dr. Emanuel Charpentier and Dr. Jennifer Dudna for their invention of the method of gene slicing using CRISPER-CAS 9. The prize has several social, economic, academic implications apart from the obvious scientific implications. This prize being awarded for development of technology, has some added issues of patenting, cost, misuse related to it. These topics are interesting for people interested in science, specially to youngsters who are interested in science.*

**KEYWORDS:** Science, Nobel prize, CRISPER.

## INTRODUCTION

The Nobel prize of 2020 in Chemistry was won by Dr. Emanuel Charpentier, a French microbiologist, working in Max Planck Institute of Infection Biology in Berlin, Germany and Dr. Jennifer Dudna an American biochemist from University of California, Berkeley. For the first time, two women have shared the Nobel prize in Chemistry [1]. They received the award for their discovery of a method for Gene slicing, using CRISPER-CAS 9. It is being referred to as a genetic scissor that can cut our genes in specific points accurately. This powerful technology has the power to do tremendous good as well as can be misused also. The financial implications of this discovery have led to conflicts about its patenting. This win has brought to the forefront the challenges faced by women in the upper echelons of science. It also reflects how the division of sciences have become obsolete and the importance of collaboration and communication in the scientific world. This gene slicing technology brings to light how research in basic science led to development of a technology and how this technology needs to be made available for common good. This article takes a

look at different aspects of this win and how it encourages more women to science.

## DISCUSSION

**The invention:** CRISPER/CAS 9 is a gene editing tool that is guided by RNA to target a DNA. It abbreviates to Cluster of Regularly Interspaced Short Palindromic Repeats and is clubbed with CRISPER Associated Genes. It consists of a single guided RNA and CAS nuclease that is able to target DNA. This repetition of sequences was first observed in bacterial chromosomes that were protecting them from attacking viruses. Within these repeated sequence some portions were unique in nature. Origins of these unique sequences were traced back to a virus that had previously infected the bacteria. The reflection of this viral sequence gets imprinted within the bacterial immune system. When the virus attacks the bacteria again, it is able to fight off the viral infection with the help of its micro-RNA and the unique repeated sequence or CRISPER. Another set of sequence, CAS-9 or CRISPER Associated Sequence of genes is always present alongside these unique sequences. The CAS-9 nuclease and microRNA are responsible for destroying the viral





DNA of the attacking virus. Hence, the combination of CRISPER-CAS 9 is able to identify a DNA sequence and cut it. Therefore, it was later developed as a technical tool. There are three types of CRISPER/CAS systems each with several subgroups. They consist of a CAS endonuclease, a CRISPER RNA (cr RNA) and a transactivating crRNA (tracr RNA). The latter two form a duplex structure, a guide RNA. This can be replaced by a synthetic single guide RNA (sg RNA) which consists of 20 unique base pair sequence that is complimentary to the targeted DNA. They bind together by base pairing and CAS 9 precisely cleaves the DNA [2].

**Use and possible Misuse:** DNA is the storehouse of information of all our genetic traits. Hence, a technology as powerful as this has the potential to being used as well as abused. The efficiency and affordability of the technology makes it even more so. At its best it can be used to treat a number of serious diseases that are caused by genetic defect like sickle cell anaemia, thalassemia etc. It can also be used to develop crops with better growth, less infection. The main focus of the application in the field has been in agriculture and medicine. It can be used to genetically modify other species as well, which can lead to imbalance in environment and biodiversity. Genetically modified species can be potentially used in biological warfare. The scientists are well aware of the potential misuse of this technology. To prevent that they are in the committees that will control the use of the product [3].

**Women in Science:** The world is reeling under the disease COVID-19, that is extremely infectious and one of the ways of containing it has been the method of lockdown and physical distancing. The world has learnt of the words, work from home. Most of the software companies are preferring work from home, educational institutes are doing online classes etc. Most of the household with working women are seeing women working from home. Surprisingly the lockdown has seen a decrease in the papers published by women. The household work has in this crisis fallen on women and they are the one responsible for juggling career and home. In this respect it is important and heartening that two women have shared the Nobel prize for chemistry in the year 2020. Prior to this there were only 5 women chemists who have received the Nobel prize. Madam Curie was the first woman to win a Nobel prize alone, in 1911 for her second Nobel prize in Chemistry for the discovery of Radium. In 1964 Dorothy Crowfoot Hodgkin again won the Nobel prize unshared for using X-ray to determine structures of various biochemical molecules. The other three women scientists Irene-Joliot Curie in 1935, Ada E. Yonath in 2009 and Frances Arnold in 2018 won the Nobel

prize as part of a team with other male scientists. There are only seven women scientists out of 185 scientists who have won the Nobel prize in chemistry, i.e a mere 3.8%, it shows that the participation of women in the highest echelons of science is still very less[4]. The premier institute of India Indian Institute of Science (IISc) Bangalore has only 10% female students as per the latest report. The representation of women in STEM (Science, Technology, Engineering and Management) has always been less. In USA only 33% of the doctoral degree holders are women and outside USA it is 25% [5]. This prize shows us that more and more women are breaking the glass ceiling. However it should be remembered that for a person of science, their main identity is of a scientist, irrespective of their gender. However, socially the reality is different. There is still a taboo of girls studying science subjects. Girls are encouraged to take up subjects of humanities or liberal arts. Difficulty of the subject, use of mathematics, practical work or excursions in curriculum is the various reasons for which girls are discouraged to study science subjects. Girls often do not get a chance to pursue higher studies and their career seriously as the traditional role of women is as a home maker. There is a dearth of role models for young girls in science. The media does not do any justice to this matter. Either the issue of women scientist are not discussed or even when it is discussed, her role as women balancing both family and workplace is given more attention than her achievements as a scientist. This prize and the discussion surrounding it will definitely encourage more girls to study science.

**Speed of Research:** As per the will of Alfred Nobel, the award is given to the notable achievements of the previous year; however, the gap between the invention and the award is rarely that. The minimum year between the awards have been less than a year for Irene and Frederic Joliot- Curie however, the longest wait has been almost 50 years for Osamu Shimomura. The average gap between the published work and Nobel prize win is almost 20 years[6]. The prize for CRISPER was received mere 8 years after the paper was published. This shows the pace at which science has been progressing in the modern era. The reason for this is development in correspondence, communications and extensive collaboration between laboratories across the world. The advancement of the development of the CRISPER technology from the basic scientific knowledge took lot less time due to that. Another example of the fast paced science has been the way the scientific community of the whole world came together to develop vaccines for COVID-19.

**Basic science and development of technology:** Scientific research provides us with knowledge that



helps in development of technology. Dr. Dudna credits her colleague Dr. Jillian Banfield for introducing her to the field of a repeated sequence in bacterial chromosome, that she surmised may have some connection with m-RNA. They started off with all the biochemical and basic fundamental characterization of the proteins, RNA and its combination, which later on turned out to be technically viable. Technical advances help in development of ambitious scientific experiments. A simple technology of cathod ray tube was responsible for the discovery of X ray a deciphering the structure of DNA. Hence, Science and Technology helps each other in progressing[7].

**Division of subjects:** Prof Dudna is a biochemist and Prof Charpentier is a microbiologist, but their Nobel prize was in chemistry. The three subjects Chemistry, Microbiology and Biochemistry have traditionally been taught as different subjects with own structured syllabus. It reiterates the fact that these divisions of science are mere, superficial. The main focus is the problem and knowledge is merely a tool to solve the problem at hand, from whichever subject it might come from. Hence, it is important not to be rigid about the scope of the chosen subject. The new National Education Policy of India also encourages interchange of knowledge between different subjects. The concentration of a researcher should be on solving the problem being as creative as possible about the means for it.

**Love of Subject:** The main motivation of any scientist is to pursue science with objectivity and passion. It is true not only for science but for all other subjects and fields. Regardless of the position in which one serves the subject it is important to study it with love and a childlike curiosity that must last a lifetime. It is important therefore to choose a subject depending on the love for the subject rather than its ability to give a lucrative career in future. Indian families have a tendency to push children to pursue a career path that may not be to their liking. However, in recent times with various new opportunities and access to the world via internet, this tendency is reducing. When students go forward in a subject chosen according to their choice and passion, they can avoid burnout, boredom and frustration in their career and fight even when there is a rough time.

**Affordability of the Technology:** The world around us has become extremely technical, more so in the advent of the pandemic, where many physical interactions have been replaced by technology. It has made us more aware of the importance of it and the necessity of it to be made available to all strata of the society so that there is no “digital divide”. The CRISPER technology has shown remarkable promise to be potentially useful in treating various genetic diseases. Advanced clinical study has been made in

treatment for sickle cell anaemia, a genetic blood disorder and inherited childhood blindness. Fortunately the technology is affordable at present. The inventors have the intention of making it available to all. However, it is yet to be seen how it will be mass produced and marketed in the future.

**Financial Aspect and Patenting :** Unfortunately, a technology as potentially profitable as CRISPER will have its share of controversy. University of California, Berkeley and MIT-Harvard Broad Institute had filed for the patent rights, as the two stalwarts Dr. Jennifer Dudna and Dr. Feng Zhang are from the two institutes respectively. Dr. Dudna, Dr. Zhang and Dr. Emanuel Charpentier are a part of a total of 10 companies for the use of the technology or part of it and are all players in the legal battle. In whichever way the patenting rights go, it should not hinder the research in the field both academically and industrially [8].

## CONCLUSION

Any recognition brings with it a set of responsibilities, more so for a prize as prestigious as the Nobel. There are nowadays other prizes financially more lucrative than Nobel prize but it has maintained its tradition of being the most coveted. The Nobel prize for Chemistry this year is unique in many ways. It has brought to focus the position of women in science along with the importance of women education especially in Science. It also showed us how blurred the division of subjects are and the importance of collaboration in science in current research. The prize this year being given to a technological tool brings to fore the controversial world of patenting and the final cost of a viable technology to the needy. This powerful, efficient, easy and affordable tool for gene slicing also brings with it the ethical issues of how far can a researcher go with gene modifications. The opportunity for good and bad is enormous and there is also the effect it can have on biodiversity. The grey areas in environmental laws and laws on genetic modifications have to be reviewed with respect to the progress in the field. The leap to technology from science for CRISPER was very fast. It brings to front the importance of basic research in Science without regards to the outcome. Hence, basic research is any discipline has to be encouraged in governmental levels. Last but not the least this prize as with any other prize in any field shows us that love for a subject should be the only guiding force in choosing a subject so that sustained interest can be maintained in it for long term.

**Acknowledgements:** Acknowledgement is due to Shri Shikshayatan College. This article was written without any financial assistance.



## REFERENCES

1. M. Jinek, K. Chylinski, I. Fonfara, M. Hauer, J.A. Doudna, E. Charpentier, (2012) "A programmable dual-RNA-guided DNA endonuclease in adaptive bacterial immunity". *Science*. 337(6096), p.p:816-21.
2. M. Martinez-Lage, P.Puig-Serra, P.Menendez, R.Torres-Ruiz, S. Rodriguez-Perales, (2018), "CRISPR/Cas9 for Cancer Therapy: Hopes and Challenges", *Biomedicines*, 6(4),p.p: 105.
3. A.L. Caplan, B. Parent, M. Shen, C. Plunkett, (2015) "No time to waste—the ethical challenges created by CRISPR." *EMBO rep*, 16, p.p: 1421-1426.
4. M. Mahmoudi, J. A. Poorman, J. K.Silver, (2019)," Representation of women among scientific Nobel Prize nominees", *www.thelancet.com*, Vol 394 November 23.
5. M. Meadows, "Where Are All the Talented Girls? How Can We Help Them Achieve in Science Technology Engineering and Mathematics?",(2016), *Journal for the Education of Gifted Young Scientists*, 4 (2) , p.p: 29-42 .
6. <https://www.chemistryworld.com/nobel-prize/the-data-behind-the-nobel-prizes/4010453.article> (accessed 3.6.2021)
7. H Brooks,(1994), "The relationship between science and technology",*Research Policy*, 23(5), p.p: 477-486
8. P. Webber, (2014) "Does CRISPR-Cas open new possibilities for patents or present a moral maze?" *Nature Biotechnology*, 32(4), p.p: 331-333.



# CROP INSURANCE: A PATH TO DEVELOPMENT FOR GREEN INDIA

**Dr. Vinod Kumar Dave\***

\* Principal and HOD (Accounting), Shree Kheteshwar Mahavidhyalaya, Jodhpur (Raj.)

Article DOI: <https://doi.org/10.36713/epra7507>

DOI No: 10.36713/epra7507

## ABSTRACT

*This paper discusses about the crop insurance and its effects on development by green India. It attempts some facts of Indian agriculture and innovation in it through crop insurance; firstly, it discusses about the Indian agriculture its nature and characteristics, secondly, it focuses on crop insurance and rural development of India finally it provide some data of agricultural production enhance in India with introduction of crop insurance. Author depends on some research paper and reports of related study. Literature surveyed by author for identification of crop insurance and its effects on Indian agriculture. The paper aims to provide some suggestion and remedies to development of rural India with better policies of crop insurance.*

**KEY WORDS :** Crop Insurance, Green India, Indian Agriculture, Rural India

## INDIAN AGRICULTURE : NATURE AND CHARACTERISTICS

India is an agricultural country, the villagers of India are directly or indirectly dependent on agriculture, cultivates land for livelihood. Many farmers cultivates own land, and then some farmers uses those farmers land who have little human and technical resources to cultivates their own holding of land. The prominent source of income of people living in villages of India is from the produces of their farming, they live their household and social life with the same yield. The excessive part of Indian agriculture land depends on the monsoon, year after year, variation found in monsoon that affected yield of farmers.

Crop insurance is ray of hope for Indian farmers; it is a boon for them. Agriculture insurance assures farmers for a certain amount of income for their crops in a few types of complexities. A wide range of benefits of insurance to insurer resulted to wake up trust in insurance companies to cover their risk regarding crop loss.

## RURAL INDIA : MEASURES OF DEVELOPMENT

Development is blend of numerous belongings with the intention of makes inhabitant life easier and friendly. The development is not visible therefore; every nation measures it on behalf of National Income, Per Capita Income and comparative study over previous year's growth rate. On other hand qualitatively, it measures on health, education, living standards of people and sanitation facility of state. A particular region can be measured it on basis of environmental appropriateness to human life and communications advantage to people. Environmental appropriateness to human life involve fresh air, food and happier environment, and communication of exacting end involve transportation facilities as well as other sources like mobile, internet and postal services.

Faring and forestry is playing significant role in rural development of India for the reason that Indian rural communities are having farming as a prominent occupation. Many agencies that are working for rural development of India have conventionally focused on the utilization of land such as farming and forestry.



Government of India has a vision of developed rural India on basis of agriculture by using land resources as well as using people inherent talent for agriculture. All agencies and Govt. of India are has focused on well-being of human and economic growth of people by farming.

### **RURAL INDIA : AGRICULTURAL ECONOMY**

Indian agriculture is private and farmers has own land and resources to cultivate his land. Private farming of India move forward farmers to cultivate it with own resources without help of government endeavors. This private agriculture is still depend on monsoon, a petite vary in monsoon volatile yields of farmers. In this scenario, Indian agriculture is high risk-oriented and beyond control of farmers efforts. Low and high monsoon has its own limitations but both conditions affect farmers farming badly and farmers suffer huge loss in farming yields. Inverse conditions, flood, license of commercial agriculture and many more formalities of government are other obstacles to Indian farmers.

Indian agriculture is always synonym of hard labor and low income. Farmers' state of affairs becomes dreadful year on year due to lower attentions on a particular policy to agriculture system. The negligence of government, low income and adverse conditions of agriculture dissolved the farmers of India. The migrating of the farmers from the villages to the villages was not new. To flee from the villages of the farmers in the hope of better work, the new chapter was established in the absence of the agriculture income in farming. Although it was not easy for the farmers to migrate from the villages to the cities, but farming nature and attitude forced them to do so. The escape of the farmers was not a mere farmer's family escape; it was like the escape of nature, because the impact on the scenic scenes of cattle and nature was visible from their escape, which used to push back the story of development of villages.

Agricultural development is genuine development of rural India. Before development of agriculture and rural India, government has major challenge to control of migration of farmers. To stop migration government need assure farmers for minimum income from their crop. Agricultural insurance has assured farmers for minimum income, which has encouraged farmers' morale. High morale of the farmers started turning towards the work of farming. Being certified for minimum income, farmers have started using innovative technologies, chemical fertilizers and more yielding methods. Agricultural insurance has assured farmers to bring them back to the fields, while the farmers have started commercial cultivation, thereby increasing their income.

### **CROP INSURANCE : STORY OF RURAL DEVELOPMENT**

Indian agricultural activities are intrinsically occupied jeopardizes and uncertainties. Risk and uncertainties of agriculture was not competent to farmers pull towards innovative agriculture and employ elevated category technologies to nurture farming and its yield. In presence of this risk-oriented scenario of Indian agriculture, Crop insurance was a boon to reducing the agricultural risks indemnifies the fatalities arising from catastrophic weather. Crop insurance brings security and stability in farmers' income with diversified agriculture on risk protected agriculture (Prakash & Sharma, 2014). In case of crop loss of any other fatalities farmer acquire ready money from insurance company that enable farmer to avoid selling livelihood assets or obtain loan from *Mahazans*.

Crop insurance enhances confidence of farmers for inventive cropping by taking more risk on assured reward against crop failure. Farmers' high confidence shifts them in money-making crop growing to a certain extent of customary agriculture of food grains. In most recent few decades commercial agriculture grow in India after launching of crop insurance policy by government of India.





**Table : All India Crop-wise Yield  
(Quintal/Hectare)**

Crops	1950-51	1990-91	2000-01	2010-11	2011-12	2013-13	2013-14	2014-15	2015-16	2016-17*
Rice	6.68	17.40	19.01	19.01	23.93	24.61	24.16	23.91	24.00	25.50
Jowar	3.53	8.14	7.64	9.49	9.57	8.50	9.57	8.85	6.97	8.89
Bajra	2.88	6.58	6.88	10.79	11.71	11.98	11.84	12.54	11.32	13.11
Maize	5.47	15.18	18.22	25.40	24.78	25.66	26.76	26.30	25.63	26.64
Wheat	6.63	22.81	27.08	29.88	31.77	31.17	31.45	27.50	30.34	32.16
Cereals	4.08	9.00	10.27	15.31	15.90	16.17	17.17	17.03	15.79	17.84
Gram	4.82	7.12	7.44	8.95	9.28	10.36	9.60	8.88	8.40	9.73
Tur	7.88	6.73	6.18	6.55	6.62	7.76	8.13	7.30	6.46	8.85
Total Pulses	4.41	5.78	5.44	6.91	6.99	7.89	7.64	7.28	6.56	7.79
Total Food grains	5.22	13.80	16.26	19.30	20.78	21.29	21.20	20.28	20.42	21.53
Sugarcane	334.22	653.95	685.78	700.91	703.17	682.54	705.22	715.12	707.22	698.86
Groundnuts	7.75	9.04	9.77	14.11	13.05	9.95	17.64	15.52	14.65	14.24
Mustard	3.68	9.04	9.36	11.85	11.45	12.62	11.85	10.83	11.83	13.24
Soy Bean	4.26	10.15	8.23	13.27	12.07	13.53	10.12	9.51	7.38	12.19
Sunflower	6.53	5.35	6.05	7.01	6.92	6.55	7.50	7.36	6.08	6.99
Total Oilseed	4.81	7.71	8.10	11.93	11.35	11.68	11.68	10.75	9.68	12.25
Cotton	0.88	2.25	1.90	4.99	4.91	4.86	5.10	4.62	4.15	5.19
Tobacco	7.31	13.53	13.18	16.87	16.13	15.42	16.12	18.42	17.81	NA

NA: Not Available

Source: Directorate of Economics and Statistics, DAC&FW

## LITERATURE REVIEW

Crop insurance is a tool of minimizing risk of farmers as well as it is tool of risk bearing for innovative and commercial agriculture. Higher innovation and scarification of farmer on behalf of crop insurance increases the production efficiency of farmers (Roberts, 2007). In present time, an insurance company facilitates farmers to choose right crop through index yield of particular region. Agricultural insurance companies are regularly focuses on own returns therefore, insurers are focusing on advanced technologies to reduce risk of crop loss of farmers. Technological advancement and crop awareness programs are organized by insurance companies on time of cropping that reduces risk of farmers and insurers both. After all, Crop insurance reduces vicious circle of loan from *mahajans*.

Farmers' trust and encouragement from agricultural insurance have resulted in this, as a result of which today agricultural policies have got significant place in national policies. The National Policy on Agriculture that seeking for actualize the vast untapped growth potential of Indian agriculture, strengthen rural

infrastructure to support faster agricultural development, promote value addition, accelerate agro-business growth, create opportunities for workers, ensure a fair standard of living for farmers and agricultural workers and their families, discourage migration to cities, and meet the challenges faced by economic liberalization and globalization. All these efforts made by the government are directly related to the development of the villages, but the relationship of agricultural insurance is indirect.

Development of agriculture affected employment and wage rate of rural agricultural labor. Rural wages have been rising across worldwide but rates of rural Asia on higher rate, particularly since 2000. Higher rate of labor drive out due to high demand of farm labor as well high efficiency of labor in regard of cropping and harvesting of crop yield. On other hand, Commercial cultivation being expensive, skilled laborers are required, increasing rates of agricultural wages due to requirements of the skilled laborers in farms. Rising wages of rural labor have three important consequences: it reduce poverty by



setting a floor to low rural incomes; they push up the costs of agricultural production (Wiggins, 2016).

### THE STUDY'S OBJECTIVES

1. To research the evolution of India's crop insurance policy.

2. To assess the current state of the Crop Insurance Scheme and its prospects.

3. To investigate the causes of implementation failures and make recommendations for changes to the Crop Insurance Scheme.

### CROP INSURANCE INITIATIVES OR SCHEMES :

Serial	Year	Initiatives or Schemes
1.	1972-1978	First individual Approach Scheme
2.	1979-1984	Pilot Crop Insurance Scheme (PCIS)
3.	1985-1999	Comprehensive Crop Insurance Scheme (CCIS)
4.	Rabi 1999- 2000 to Rabi 2013-14	National Agricultural Insurance Scheme (NAIS)
5.	Rabi 2010-11 season	Modified National Agricultural Insurance Scheme (MNAIS)
6.	2007-08	Weather Based Crop Insurance Scheme (WBCIS)
7	2009-10	Coconut Palm Insurance Scheme (CPIS)
8.	2016	Pradhan Mantri Fasal Bima Yojana (PMFBY)

### CROP INSURANCE HISTORICAL BACKGROUND

#### 1. First Individual Approach Scheme (1972-1978)

Different kinds of trials on crop insurance on a small, ad-hoc and dispersed scale were begun from 1972-73 when the General Insurance Corporation (GIC) of India launched a Crop Insurance Scheme on H-4 cotton and subsequently added groundnut, wheat and potato. Andhra Pradesh, Gujarat, Karnataka, Maharashtra, Tamil Nadu, and West Bengal were among the states to implement the scheme. It lasted up to 1978-79 and insured just 3,110 farmers for a premium of Rs.4.54 lakh against claims of Rs.37.88 lakh.

#### 2. Pilot Crop Insurance Scheme (PCIS) (1979-1984)

The Pilot Crop Insurance Scheme was established by the GIC in 1979, which was based on the 'Area Approach' for providing insurance protection against a shortfall in crop production below the threshold level. The Scheme included cereals, millets, oilseeds, cotton, potato and chickpea and it was limited to loanee farmers of institutional sources on a voluntary

basis. The PCIS 1979 was implemented in 12 states until 1984-85 and covered 6.23 lakh farmers for a premium of Rs.195.01 lakh against claims of Rs.155.68 lakh over the whole time.

#### 3. Comprehensive Crop Insurance Scheme (CCIS) (1985-99)

The Comprehensive Crop Insurance Scheme (CCIS) established in 1985 was the first nation-wide Scheme. Previous Schemes were either experimental or Pilot Projects, on a limited size and in a dispersed way. This program was connected to short-term financing and was based on the 'homogenous area approach'. The Central Government launched the CCIS during the year 1985-86. Till Kharif 1999, the Scheme was approved by 15 States and 2 Union Territories (UTs) (UTs). Both, PCIS and CCIS were limited exclusively to farmers who had received seasonal agricultural loans from banking organizations. The major difference between PCIS and CCIS was that PCIS was on voluntary basis while CCIS was obligatory for loanee farmers. The CCIS insured 763 lakh farmers for a premium of Rs.404 crore against claims of Rs.2303 crore. A more comprehensive Scheme, 'National Agricultural



Insurance Scheme was established in 1999 with objective to insure all farmers irrespective of loanee or non-loanee.

#### **4. National Agricultural Insurance Scheme (NAIS)**

The National Agricultural Insurance Scheme (NAIS), with the goal to improve coverage of farmers, crops and risk commitment, was implemented in the nation from Rabi 1999-2000 replacing the previous Comprehensive Crop Insurance Scheme (CCIS). The primary aim of the Scheme was to safeguard the farmers from the agricultural losses experienced on account of natural catastrophes, such as, drought, flood, hailstorm, cyclone, pests and diseases. The Scheme was executed by the Agriculture Insurance Company of India Ltd. (AIC).

The Scheme was accessible to all the farmers both loanee and non-loanee irrespective of their amount of property. It envisages coverage of all the food crops (cereals, millets and pulses), oilseeds and annual commercial/horticultural crops, in respect of which historical yield data is available for sufficient number of years. The Scheme was extended until Kharif 2013, however, certain States are permitted to utilize NAIS during Rabi 2013-14 as well.

The Scheme was optional for States/Union Territories (UTs) and it had been adopted by the 25 States and 2 Union Territories in one or more seasons. Since the commencement of the Scheme 2084.78 lakh farmers for a premium of Rs.8,67,121 lakh against the claim of Rs.25,37,558 lakh were covered till 2012-13. The total area insured was Rs.3137.70 lakh hectares over the same time.

#### **5. Modified National Agricultural Insurance Scheme (MNAIS)**

To enhance further and make the Scheme simpler and more farmer friendly, a proposal on Modified National Agricultural Insurance Scheme (MNAIS) was created and was accepted by Government of India for implementation on trial basis in 50 districts from Rabi 2010-11 season.

During the Five seasons of its implementation in 17 States, the MNAIS insured 45.80 lakh farmers for a premium of Rs.1,08,800 lakh against the claim of Rs.86,400 lakh till Rabi 2012-13. The total area insured was 46.79 lakh hectares over the same time.

#### **6. Pilot Weather Based Crop Insurance Scheme (WBCIS) :**

With the aim to bring more farmers into the fold of Crop Insurance, a Pilot Weather Based Crop Insurance Scheme (WBCIS) was established in 20 States in 2007. Apart from Agriculture Insurance Company of India, several private firms have also been authorized to execute the Scheme. The WBCIS is designed to offer insurance protection to the farmers against unfavorable weather occurrences, such as deficiency and excess rainfall, high or low temperature, humidity etc. which are considered to affect negatively the agricultural output. It has the benefit to resolve the disputes within shortest feasible period. The WBCIS is based on actuarial rates of premium but to make the Scheme appealing, premium actually levied from farmers has been limited at par with NAIS.

The WBCIS was implemented in 18 States and 469.38 lakh farmers were insured for a premium of Rs.7,51,920 lakh against the claims of Rs. 52,860 lakh under the Scheme from 2007-08 to 2012-13. The total area insured was 632.01 lakh hectares over the same time.

#### **7. Pilot Coconut Palm Insurance Scheme (CPIS)**

The Coconut Palm Insurance Scheme (CPIS) was authorized for implementation on pilot basis for the years 2009-10 and 2010-11 in the chosen regions of Andhra Pradesh, Goa, Karnataka, Kerala, Maharashtra, Odisha and Tamil Nadu. Later on, it was expanded to West Bengal too. The pilot was executed during the years 2011-12 and 2012-13 and continues to be under execution during the year 2013-14 as well. Fifty percent of the premium is provided by Government of India, 25 percent by the relevant State Government and the remaining 25 percent by the farmer. The CPIS is managed by the Coconut Development Board (CDB). Under the Scheme, 51,108 farmers were insured for a premium of Rs.167.69 lakh against the claims paid of Rs.214.05 lakh until December 2013. And the total area covered over the same time was 25,938 hectares.

#### **8. National Crop Insurance Programme (NCIP)**

To make the Crop Insurance Schemes more farmer friendly, a restructured Central Sector Scheme in the name of 'National Crop Insurance Programme' (NCIP) was launched from Rabi 2013-14. The previous MNAIS, WBCIS and CPIS were combined under this project with numerous upgrades and adjustments for adoption across the nation. However,



on the basis of petitions submitted, certain States have been permitted to adopt NAIS during Rabi 2013-14.

The coverage of NCIP in terms of farmers and area insured has been predicted to the level of 50 percent each from the current level of approximately 25 percent and 20 percent respectively by the terminal year 2016-17 of the Twelfth Plan. The coverage under CPIS is anticipated at 25 percent of coconut farmers during 2013-14 with growth of 5 percent each year throughout remaining years of Twelfth Five Year Plan.

### **ADVANTAGE OF CROP INSURANCE IN DEVELOPMENT**

Crop insurance has given a new hope to the farmer. India's agriculture has always been considered a 'monsoon gamble'. Whenever the farmer sowed the crop, his mind was worried about the damage caused by natural and other calamities. But in the present time crop insurance has become a special tool for him, so that he can reduce his chances of loss to a great extent. The farmer can insure his potential losses up to a limit in return by paying a nominal amount. With the assurance of compensation by the insurance company for his possible losses, the farmer has started doing more risky farming in place of traditional farming.

Risky farming refers to such farming which is to be done commercially with the help of modern equipment instead of having traditional methods and grain products. The assurance of the insurance company is proving to be a boon for him behind the cultivation of commercial and fruit orchards. In particular, the number of trees and gardens is increasing rapidly in rural areas of India due to the planting of fruit orchards. The farmers of India have now started cultivating more than once, in such a situation that more water is being given artificially in the fields. Today even in desert areas like Rajasthan, clumps of trees have started appearing on the bunds of the fields.

With the assurance of insurance, where the farmer has started doing commercial farming, then keeping in mind the shade in the fields, he has started planting trees in sufficient quantity on the bund. In such a situation, plantation has started rapidly in the rural areas of India. Greenery is also increasing due to rapid plantation. In Israel, the deterioration of agricultural incomes in the last two decades has been perhaps more extreme than in other countries, as a result of a sharp decline in government support and protection (Kislev

& Yoav, 1992). In comparison of international scenario Indian government helping farmer so, it is a great hope for us development as well green India.

### **PROBLEMS CONNECTED TO CROP INSURANCE**

Agriculture is the primary pillar of the Indian economy it forms the backbone of rural livelihood security system. Agriculture in India is diverse, diversified and prone to a range of hazards. It is the core planned economic development in India since the trickle-down effect of agriculture is important in the decreasing poverty and regional inequalities in the nation. Most farmers are tiny and marginal ones. In most regions, agriculture is rain fed, leading to a higher degree of production unpredictability and risk.

Growth in agriculture has a maximum cascade effect on other sectors leading to distribution of growth, equality and benefits across the whole economy. The entire geographical area of the nation is 328.7 million hectares of which 141 million hectares is the net sown area, 190 million hectares is the gross cropped area. The agricultural industry represents approximately 20 per cent of the GDP and gives employment to 58 per cent of the workers.

Crop Insurance, which aimed at tackling yield risk—though essential for a large majority of farmers—is susceptible to structural, design and financial issues. Problems of asymmetry of information—moral hazard and adverse selection—and co-variability are more apparent in crop insurance than in other types of insurance. Consequently, crop insurance systems confront numerous difficulties. In response to such issues, Schemes based on the area concept were developed in the 1980s. More modern Insurance Schemes are based on weather, and use an area approach. Due to the breadth of the nation, huge number of small and marginal farmers, and adoption of area-based methods, many agencies and organizations are engaged in crop insurance schemes.

Hence, coordinated efforts are essential for successful implementation of crop insurance program. There are numerous flaws in the execution of the Crop Insurance Schemes. The numerous problems connected to Crop Insurance such as:-

- Paucity of the financial resources of the State Government.
- Regular occurrence and intensity of natural disasters.
- Unreliable estimate regarding crop damages.
- Improper Land records.





- Growing sub-division and fragmentation of land ownership.
- Abject economic destitution of the small and marginal farmers.
- Illiteracy and stupidity of the farmers.
- Lack of co-ordination between Govt. With various insurance organizations.
- Discrepancy in area insured.
- Delay in getting crop – cutting data and quality and dependability of such data.
- Weather data.
- Crop loan practices.
- Crop insurance premium.
- Settlement of Claims.
- Role of Banks and Agricultural Insurance Companies in the functioning of programs and
- Awareness of farmers about different aspects of the Schemes.

### A STEP AHEAD

In the last few years, there has been rapid progress of greenery in rural areas of India. Along with the production of crops, there has also been progress in the production of fruits, which is a proof of growing trees. Apart from all these things, there is still a lack of complete knowledge of scientific changes in agriculture and mechanical equipment in many areas. The lack of schemes by the government to encourage farmers to plant trees in addition to insurance is still a major obstacle in the entire Green India.

Nevertheless, experts are hopeful that in the coming years there will be a progressive increase in the number of trees in rural areas of India. Indian farmers are trying to earn extra income by cultivating fruits and cultivating timber along with traditional farming. Today, farmers are trying to increase their income, in such a situation, planting tall trees on their agricultural land; they can cultivate vegetables and small plants below. At the same time, keeping in mind the need of shade in the fields for the scientific thinking of the farmers and also for the cultivation of cold climate, progressive progress in the number of trees in the fields is abound in the near future.

Promotion of agricultural productivity by competitive activities. Investment in agriculture – fishing, forestry, irrigation and drainage, agricultural trade, and agribusiness – has increased significantly (Worlds Bank, 2007). With extent of agriculture an agriculture economy based country like India economy increase on higher growth rate with development of subsidiary activities.

### SUGGESTIONS AND REMEDIES

After the introduction of crop insurance, there has been a gradual progress in the production of crops in India. The number of trees has also increased in rural India. Today the Government of India is trying to double the income of the farmers, so efforts should be made to promote the cultivation of fruits along with traditional crops. Efforts should be made to promote more than one crop (fruits and cereals) in the same field at a time. With such a step of the Government of India, it is possible to increase the income of the farmers as well as the development of rural India.

A web gateway should be established for all States to allow land record data be accessible to financial institutions. Premium rates to be reviewed for MNAIS. Reserve Bank of India (RBI) and National Bank for Agriculture & Rural Development (NABARD) should properly monitor the compliance of their circulars on obligatory crop insurance for loanee farmers. Insurance firms and banks should play a pro-active role in ensuring efficient execution of crop insurance programs. State Governments should guarantee the usage of GPRS-enabled and camera equipped mobile phones etc. when undertaking crop cutting trials. An Atlas of key weather components for various agro-climatic areas and An Agricultural Insurance Act should be developed to take account of particular requirements of the crop insurance and agricultural insurance in general.

For the development of rural India, such efforts should be made by the government so that where farmers are interested in farming on one hand and on the other hand they are encouraged to do farming through scientific methods. By doing this, there is bound to be an increase in the income of the farmers. The Government of India should provide assurance to the farmers to get income from insurance to a certain extent in addition to financially supporting them. Include all those facts in the insurance, due to which there is a possibility of loss to the farmer and help centers should be opened in rural areas to give them the right advice.

### CONCLUSIONS

Crop insurance has awakened the interest of farmers to do farming through scientific methods and get more income. Today the increasing agricultural production is the result of the government's crop insurance policies. Especially in rural India, increasing greenery is the result of the advanced policies of today's government, but the failure of the government





to achieve international level in the income of farmers. The government is trying to increase the income of the farmers, it can be seen clearly. To encourage the farmers, the government is also giving money directly to the farmers in various ways, so that the farmers can have a positive attitude towards farming and rural India can develop.

Crop insurance has not only increased the production of food grains, it has also increased commercial and fruit cultivation. If the government changes some policies and encourages the farmers to do more than one farming at a time (cultivation of high trees and low food grains), then in the coming days there seems to be a strong possibility of full development of India's overall development from Green India.

## REFERENCES

- Jodha, N.S. (1981). *Role of Credit in Farmers' Adjustment Against Risk in Arid and Semi-Arid Tropical Areas of India. Economic and Political Weekly. XVI (22&23).*
- Kislev, & Yoav. (1992). *problems connected to Crop Insurance Family Farms, Cooperatives and Collectives. Aldershot, England: Dartmouth: G.H. Peters and B.F. Stanton.*
- Mishra, P.K. (1994) : *Crop Insurance and Crop Credit : Impact of the Comprehensive Crop Insurance Scheme on Cooperative Credit in Gujarat. Journal of International Development. 6(5) : 529-68.*
- Bhende, M.J.(2002). *An analysis of Crop Insurance Scheme in Karnataka. Bangalore: Agricultural Development and Rural Transformation Unit, Institute for Social and Economic Change (ISEC).*
- Jain, RCA (2004): *Challenges in Implementing Agriculture Insurance and Re-insurance in Developing Countries, The Journal, January-June, pp 14 -23.*
- Bank, W. (2007 ). *Agriculture and Rural Development . World Bank Issue Brief.*
- *Agricultural Statistics at a Glance (2007): Agricultural Statistics Division, Department of Agriculture and Co-operation, Ministry of Agriculture, GOI, New Delhi.*
- Roberts, M. J., O'Donoghue, E., & Key, a. N. (2007). *Does Crop Insurance Affect Crop Yields? Annual Meeting of the AAEA., (pp. 1-18). Portland, Oregon.*
- Prakash, R., & Sharma, R. (2014). *Appraisal and Future of Crop Insurance Schemes in India with Special Reference of NAIS. 86-92.*
- Wiggins, S. (2016). *Agricultural and rural development reconsidered A guide to issues and debates. IFAD.*



## GOING AWAY AND COMING BACK: JOURNEY OF CHANU IN MONICA ALI'S BRICK LANE

**Dr. Jyoti Rana**

*Assistant Professor, GVM Girls College, Sonipat, Haryana*

Movement from one place to another lead to various changes in social and cultural practices. Diaspora is a mode of cultural production. Cultural identity is fluid, produced and reproduced so that it often results in hybrid forms of expressions. The issues dealt in diasporic literature are issues of identity, the problem of history, confrontations with racism, intergenerational conflicts, difficulties in building new supportive communities, alienation, and rootlessness. Diaspora is not merely a scattering or dispersion, but an experience determined by who travels, where, how and under what circumstance. Homelands, and even the lands of adoption, crop up between the imaginary and the real. The diasporic writers exemplify the disturbing shifting and enliven the past cultural heritage and tradition in their works.

The novel *Brick Lane* (2003) by Monica Ali explores immigration, cultural shock and the problems involved in the movement from one country to another. The novel depicts the journey of Nazneen and Chanu from Dhaka to London. Nazneen migrates to London after her marriage with Chanu. Chanu is much older than Nazneen and is described as a man with “a face like a frog”. Chanu is working in London.

Chanu is the first generation immigrant with high dreams in his eyes but he suffers from going home syndrome. He came to England to earn money but when his daughters grow older he wants to go back because he does not want to bring up his daughters in this atmosphere. He thinks that this place is not suitable for his daughters. He tries to retain his ethnicity. He finds faults in the surroundings of London. He thinks that it's good to make money. He is unable to completely acculturate and assimilate in London and in the end goes back to his native land.

Chanu feels proud on his coming to England and tries to show that he is a very educated person and

thinks himself worth of living in London. He tries to show that is very much attached to his native land. He always talks about Bangladesh and tries to live according to that culture and he lives in cultural nostalgia. At home he does not want to come out of his native culture. He is always nostalgic about his culture. Although he has a lot of degrees but still he is unable to settle in London and as Dr. Azad says, he suffers from ‘going home syndrome.’ Chanu who himself is an immigrant, comments on the yearning of the immigrants in London for their native land. His comments justify the nostalgic feeling of the immigrants. “These people are basically peasants and they miss the land. The pull of the land is stronger than the pull of the blood.” (BL32) He further adds, “They don't ever really leave home. Their bodies are here but their hearts are back there” (BL32).

Chanu tries to posit that he is English and he has all the qualities which are needed in an English man. He is having degrees and he can speak English. He wants to assimilate in the host nation but due to the racial discrimination he feels alienated and marginalized. When a white man gets promotion instead of him, he feels lost and says:

You see... it is the white underclass, like Wilkie, who are most afraid of people like me.

To him, and people like him, we are the only thing standing in the way of them sliding totally to the bottom of the pile. . . .That is why you get the phenomena of the National Front. They can play on the fears to create racial tensions and give these people a superiority complex. (BL38)

Sometimes the racial discrimination makes an immigrant to feel uncomfortable in the host nation and he feels alien and lonely. This feeling becomes the



hindrance and obstacle in his acculturation and assimilation. The same situation is faced by Chanu. He faces injustice in regard to his job. This makes him feel that he is not fully accepted by the society he lives in. It is not easy to change the host culture according to the immigrants, but the immigrants would have to change themselves to adapt to the host culture.

Dr. Azad and Chanu are not able to fully acculturate themselves in the British society. When his daughter asks for money to go to pub in front of Nazneen and Chanu he feels chagrined, his deep rooted culture and traditional values come in his forefront and he feels ashamed. As such kind of attitude is not acceptable in their country. Chanu also feels abashed and talks about the immigrant tragedy. This incident shows that inspite of living in other nation it is not easy for the first generation to give up their cultural values and accept the other. For the first generation immigrants it is sometimes very difficult.

Shahana, Chanu's daughter does not consider herself Bangladeshi and relates herself with England. She belongs to second generation of immigrants. She does not like to listen to Bengali classical music" (BL180). Chanu is reluctant to nurture his daughters in England as they will move away from their land and culture. He does not want his daughters to give up their ethnic and cultural identity.

Chanu forces his daughters to learn about their culture and speak Bengali at home. He says that they must learn Tagore's poems as it will make easy for them to settle in Bangladesh. He is so nostalgic about his country that he always keeps on comparing between Bangladesh and London.

Chanu thinks that through literature they can connect to their native land. He praises his native land in front of his daughters:

He sat up a little and cleared his throat. 'In the sixteenth century, Bengal was called the Paradise of nations. These are our root. Do they teach these things in the school here? Does Shahana know about the Paradise of Nations? All she know is about flood and famine. Whole bloody country is just a bloody basket case to her.' He examined his text further and made little approving purring noises. (BL185)

Chanu tries to tell his daughters about the past of their native land. But his daughters are not interested in the past of Bangladesh. The second generation immigrants don't feel the same as their parents feel about their native land. They feel proud for their past but the second generation believe in the present. He says:

If you have a history, you see you have a pride. The whole world was going to Bengal to do trade. Sixteenth century and Seventeenth century Dhaka was the home of textiles. Who invented all this muslin and damask and every damn thing? It was us all us. All the Dutch and Portuguese and French and British queuing up to buy. (BL185)

Nazneen wants to assimilate but her language becomes barrier in her acculturation. On the other hand, Chanu has integrated in this society:

I'm talking about the clash between Western values and our own. I'm talking about the struggle to assimilate and the need to preserve one's identity and heritage. I'm talking about children who don't know what their identity is. I'm talking about the feelings of alienation engendered by a society where racism is prevalent. (BL45)

At the beginning of her life in London, Nazneen does not leave her flat and remain trapped in the flat. Her language becomes a barrier for her, as a result she feels alienated. She can speak only two words of English 'sorry' and 'thank you'. She spends her days alone; she doesn't move out of her home and does not meet the strangers. Chanu does not encourage her to learn English and finds it unnecessary. Whenever Nazneen says that she would like to learn English, Chanu reactions "Chanu puffed his cheeks and spat the air out in a fuff. 'It will come. Don't worry about it. Where's the need anyway?'" (BL37).

Nazneen tries to learn English with the help of her friend Razia but Chanu again discourages her, Chanu's attitude is the same:

'What for?'

'For the English lessons.'

'You are going to be a mother... Will that not keep you busy enough? And you can't take a baby to the college. Babies have to be fed; they have to have their bottoms cleaned. It's not so simple as that. Just to go to college, like that.' (BL77)

Nazneen suffers extreme social isolation. Able only to say 'sorry' and 'thank you' in English, Nazneen spends entire days completely by herself, cleaning the flat in which she and Chanu live, her only human contact being the sight of a mysterious tattooed lady who sits all day staring blankly out of the window of one of the facing buildings (BL7). Nazneen says that in her whole eighteen years, she can never remember having spent a moment alone until arriving in Britain (BL10)



Chanu's condescending attitude towards Nazneen elevates her isolation and alienation. Chanu does not torture her physically but psychologically he does not allow her to do anything. Chanu's pretentious didacticism alienates Nazneen, he also sees that she should not interact and intermingle with any other person from her native land. He thinks that they are uneducated yokels. (BL14)

Her life is opposite to what it used to be earlier. She feels lonely and lost in this new environment. "On one of her first days in Britain, Nazneen cuts her finger when chopping onions: 'The drops slid together like mercury and rolled down the drain. How long would it take to empty her finger of blood, drop by drop? How long for the arm? And for the body, an entire body?'" (BL24) this incident describes her loneliness. Chanu is unable to understand the alienation felt by Nazneen because of lack of communication in the new world. He does not like her association with anybody outside her house.

Chanu is divided into two. He wants to be English as well as wants his family to follow Bengali tradition and culture. He wants that his children should learn the poetry written by Tagore and must speak and write Bengali. She develops an extra marital affair with Karim. His revolutionary ideas impressed her a lot and this relationship brings a lot of change in her attitude and outlook. She started thinking about herself and her daughters.

Various cultural differences of the immigrants make them feel alienated and make their life difficult in new land. Chanu sees the life "This is the tragedy of our lives. To be an immigrant is to live out a tragedy" (BL112). There are various reasons which make an immigrant feel alienated in the host land, they see themselves as strangers and feel uncomfortable to adopt the new culture and tradition. As a result they inevitably feel alienated. The fact of being seen as 'the other' in the new environment plays a vital role to rouse the feeling of alienation. In the novel "the debilitating feeling of being an outsider, not quite being a part of the culture that one is surrounded by, is also embodied by the character of Nazneen's husband, Chanu" (Kathy A. Tan, 229). Chanu frequently mentions that the colonial process of England still continues in a different way and the West always despises them and considers the immigrant as lower. He says:

All these people here who look down at us as peasants know nothing of history...in the sixteenth century, Bengal was called the Paradise of Nations. These are our roots. Do they teach these things in the school here? Does Shahana know about the

Paradise of Nations? All she knows about is flood and famine. Whole bloody country is just a bloody basket case to her. (BL185)

The conflict with the character of Chanu's mentioned by Kathy-Ann Tan as follows:

The irony of Chanu's character is that, although he bitterly resists assimilating into British culture, hanging on to his cultural and historical roots and sense of national identity, he himself is an exaggerated parody of the archetypal product of post-colonialism, a scholar from the Commonwealth who pursues his university studies in the U.K., acquainting himself with, and steeping himself in, British culture and literature, spouting random quotes from Shakespeare to compliment the occasion. (229)

Chanu is caught between two cultures; he represents the immigrants' experiences. As stated by Catronia "Nazneen's husband, Chanu, is similarly caught. The more his desire for recognition is frustrated the more he feels alienated both from the English culture from which he once hoped to gain respect and from the East London Bangladeshi community, which is driven with internal dissension, intergenerational conflict and hostility towards the dominant culture.

Chanu is an exemplary of commingle of violent, identity related contradictions. He vacillates among his vitalizing faith that he and his family should be "English" and the rigid force which pulls him back towards the culture he has all but abandoned. Chanu tries to maintain his native identity and talks about two cultures and says that:

I'm talking about the clash between Western values and our own. I'm talking about the struggle to assimilate and the need to preserve one's identity and heritage. I'm talking about children who don't know what their identity is. I'm talking about the feelings of alienation engendered by a society where racism is prevalent. (BL45)

Chanu who is educated and has a lot of degrees, desires promotion but he does not get while other Englishman gets the promotion. Then he feels isolated and discriminated and wants to return back. Chanu could have assimilated if he would have got promotion in his job. But due to racism, he did not get promotion and he wants to return back to his native land.

Chanu returns from London to Bangladesh as he could not adjust himself. For Chanu, of *Brick Lane*, being a non-white, hostland London is so



discriminatory that he decides to go back to Dhaka alone leaving his family in London.

#### WORKS CITED

1. Ali, Monica. *Brick Lane: A Novel*. New York, Scribner, 2003.
2. Asnami, Shyam M. "Identity Crisis of Indian Immigrants: A Study of Three Novels." *Writers of Indian Diaspora: Theory and Practice*, edited by Jasbir Jain, Rawat Publications, 1998, pp. 73–81.
3. Bhabha, Homi K. *Nation and Narration*. Routledge, 1995.
4. Hussain, Yasmin. *Writing Diaspora: South Asian Women, Culture and Ethnicity*. Ashgate, 2005.
5. Tan, Kathy A. "Caught between Worlds': The Clash of Cultures and of Generations in the Work of Monica Ali, JhumpaLahiri and Zadie Smith." *Territorial Terrors: Contested Spaces in Colonial and Postcolonial Writing*, edited by Gerhard Stilz, Königshausen & Neumann, 2007, pp. 227–238.





# A STUDY OF COVID-19 IMPACT ON THE EDUCATION SYSTEM

<sup>1</sup>Mr. Sushil Bhimrao Bansode, <sup>2</sup>Miss. Sonal B. Bansode,  
<sup>3</sup>Miss. Meghana B. Bansode

<sup>1</sup>Research Student, Shivaji University, Kolhapur

<sup>2</sup>Researcher

<sup>3</sup>Researcher

## ABSTRACT

*The entire education system is affected by Covid-19. To control the situation of this epidemic, the government has chosen the path of lockdown. Due to the lockdown, all the schools and colleges are closed and it is badly affecting on the student's life. Around the world all the learners stop to movie colleges. The education sector is fighting to avoid the crises with a different approach and to keep away the danger of the epidemic, the online education system has been accepted by all the schools and colleges to reach the students. This paper highlights some of the measures taken by the Indian government in Covid-19 situation. This paper explores the responses received from the respondents and discusses the effects of COVID-19 on education and also gives some useful suggestions for carrying out educational activities during the epidemic situation.*

**KEY WORDS:** Epidemic Situation, Covid-19 Situation, Education System and Lockdown, Government initiatives etc.

## 1. INTRODUCTION

Leaving behind all the big events of last year, the corona infection has been recorded in history as the biggest event of the century. The COVID-19 has spread all over the world and is forcing the human society to maintain social distancing. This has significantly disrupted the education sector which is an important determinant of the country's economic future. In February 2020, The World Health Organization (WHO) gives the official name of the virus as COVID-19, an abbreviation for Coronavirus Disease 2019. It was first identified on December 31, 2019 in Wuhan, China. The WHO declared COVID-19 a epidemic in March 2020. The first case of COVID-19 epidemic in India was reported in January 2020 in the state of Kerala. Due to its outbreak, thousands of people died worldwide and millions of people became victims of its infection. The terror of corona virus, which has spread all over the world, has also spread to India. The central government is taking special precautions to prevent the spread of the virus. The COVID-19 epidemic has affected educational systems around the world, forcing almost the closure of schools, universities and colleges. In India, the outbreak of COVID-19 has been declared a epidemic in all its states and union territories. To combat COVID-19, the lockdown was imposed on March 25,

2020, which adversely affected the education system in the country. This Epidemic situation has changed the traditional Indian education system to modern education system or technology-based education system, where teaching and assessment are conducted online. The traditional education system is the blackboard system. Where teachers used blackboards to help teach. In which students and teachers sit in the same room and discuss a topic in front of each other. The modern education is known as technology-based system or online education system. This system used in India after Covid-19 epidemic situation. In this system Whiteboarding has replaced the blackboard. Teachers assigned assignments to students through internet, delivered lectures through live video conferencing using various apps like Zoom, Google Meet, Facebook, YouTube and Skype etc. As per the government order all school, colleges and universities start to take lectures in online mode means using whiteboarding education system.

As per the UNESCO report, it affected more than 90% of the total student population of the world in mid-April 2020 which has now come down to around 67% during June 2020. The outbreak of COVID-19 has affected more than 120 crore students. In India, over 32 crore students have been



affected by various restrictions and nationwide lockdown for COVID-19. According to the UNESCO report, around 140 million primary and 130 million secondary students are affected which are the two most affected levels in India. In view of the coronavirus epidemic situation, WHO recommends maintaining social distancing as the first prevention step. That's why every country started the action of lockdown to isolate the infected people. The education sector, including schools, colleges and universities, was closed. Classes were suspended and all examinations in schools, colleges and universities, including entrance exams, were postponed indefinitely. Thus, the lockdown destroyed the schedule of each and every student. Although this is an extraordinary situation in the history of education, COVID-19 has created many opportunities for us to move from rigid classroom teaching models to a new era of digital models.

The lockdown has forced many educational institutions to cancel their classes, exams, internships etc and opt for online mode. Initially, teachers and students were quite confused and could not understand how to face this sudden crisis situation which forced the closure of educational activities. Thus, COVID-19 has created many challenges and opportunities for educational institutions to strengthen their technical knowledge and infrastructure. The lockdown gave them a ray of hope for teachers and students to continue their educational activities through online. There are WhatsApp groups of parents, teachers, students and parents for emotional communication through which they are always in touch to share their difficulties through this e-medium. In a country like China that practices a fairly high centralization system, transitioning to digital learning can be easy. Even in a nation like the United States, there are some low-paid students who do not reach the widest band and are unable to access computerized learning systems (study abroad). The same situation is with India, where not every student is well equipped with high-speed internet and digital gadgets and is facing such problems. Many advanced educational institutions in India are also not yet equipped with digital facilities to face the sudden change from traditional education to online education system.

### **Government Initiatives During Epidemic in Education System.**

During the outbreak of Covid-19 across the country, the country is facing a major crisis in every field. And this time one of the most affected sectors is the education sector, as most of the exams have been canceled during the final evaluation. To ensure that there is no gap in education and students get full access to classes as before, HRD Minister Ramesh Pokhriyal advised students to continue their studies

using digital learning platforms. The Ministry of Human Resource Development and its affiliated institutions are promoting digital education through online educational platforms and TV and radio also Digital learning portals help students not only to get full access to study material but also allow them to engage in online classes and interact with teachers in a physical classroom setting. Here is a list of some excellent digital initiatives launched by the Ministry of Human Resource Development for school students and even those seeking UG and PG level education. Following are some online resources developed by the Indian government.

### **Diksha**

The HRD Ministry has launched the National Digital Infrastructure for Teachers (DIKSHA) portal to equip teachers from Class 1 to Class 12 with the world of e-learning. The platform is available for both teachers and students who require learning materials. Diksha is a unique app that requires students and teachers to scan the QR code available in the book to access the prescribed learning material. More than 80,000 e-books are available here for the purpose of training and enhancing the students in 12th, CBSE, NCERT and states or union territories. The portal is available to the students in multiple languages.

### **E-Pathshala**

A web portal and mobile app designed and deployed by National Council of Educational Research and Training. It has 1886 audios, 2000 videos, 696 e-books and 504 flip books for classes 1st to 12th in different languages.

### **National Repository of Open Educational Resources (NROER)**

A portal equipped with best quality informational content on diverse subjects in different languages having total 14527 files including 401 collection, 2779 documents, 1345 interactive, 1664 audios, 2586 images and 6153 videos on various languages.

### **Swayam**

It is the national online education platform hosting 1900 courses covering both school (Class IX to XII) and higher education (both UG and PG) in all subjects including Engineering, Humanities, and Social Sciences, Law and Management courses. A unique feature of SWAYAM is that it is integrated with traditional education. The courses are interactive and prepared by the best teachers in the country, and are available free of cost to any learner in the country.



### Swyam Prabha

It has 32 DTH TV channels broadcasting educational content on 24/7 basis. These channels are available to watch all over the country using DD Free Dish set top box and antenna. Now private DTH operators are also broadcasting these courses through their channels. The channels cover both schooling (Class IX to XII) and higher education in a wide range of subjects like engineering, vocational courses, teacher training, performing arts, social sciences and humanities subjects, law, medicine, agriculture and many more.

### National Academic Depository (NAD)

It run by the UGC, which has tie-ups with around 55 school boards, 359 state universities, 123 deemed universities, 47 central universities and 260 private universities.

### National Digital Library

It is a digital repository of a vast amount of academic material in various formats and provides interface support for leading Indian languages for all academic levels, including researchers and life-long learners, across all disciplines, all popular forms of access devices and different - Includes differently-abled learners.

## 2. OBJECTIVES OF THE STUDY.

1. To study the impact of covid-19 on student, teacher and parents.

2. To know various efforts taken by the Government of India for the education sector during this epidemic situation.
3. To Find out the impact of covid-19 and provide effective suggestion for continuing the education system during the any epidemic situation.

## 3. RESEARCH METHODOLOGY

The study is based on primary as well as secondary data. The primary data is collected from the selected respondent. Secondary data is collected from internet websites, newspaper, government reposts etc.

A total of 150 respondents were selected for the study. 150 respondents include 50 students, 50 teachers, 50 parents. 150-sample size selected using a simple random sampling method.

Every research there are limitation. There are some limitations to this study.

### 1. Geographical limitation

The researcher took only the city of Sangli for the study, i.e., the impact of COVID-19 on the education system established only in Sangli districts has been included in this study.

### 2. Sampling limitation

The students pursuing higher education were selected in the sampling. School level students were not taken for the study. Same things with teachers' and parents' respondents.

## 4. ANALYSIS AND INTERPRETATION OF DATA.

Table No. 1  
 COVID-19 Positive Impact in education system

Particular	Students	Parents	Teachers	Total	Percentages
Handle Digital Technology	50	50	50	150	100%
Easy to learn from any where	50	50	50	150	100%
Time saver	50	50	50	150	100%
Computer literacy increase	50	50	50	150	100%
Understanding Increase	50	50	50	150	100%

(Source: Primary Data)

Though the outbreak of COVID-19 has caused many negative impacts on education, educational institutions in India have accepted the challenges and are doing their best to provide uninterrupted support services to the students during the epidemic. The Indian education system got an opportunity to change from the traditional system to a new era. The above points can be considered as positive effects. The above table shows the positive impact of Covid 19 on respondents. 100% of respondents said that covid has a good effect. Due to covid Student, Parents and Teacher are handling digital technology. They use the internet daily for education as well as extra knowledge purposes. They learn how to use various apps and software. Students use paperless notes, they record live lectures and

listen once again, they learn to use Microsoft Office, PowerPoint presentation techniques etc. Teachers provide the online lecture they use various apps for teaching such as Whatsapp, Skype, Zoom, Google meet etc. They friendly to use Microsoft office word, excel, PowerPoint etc. Student-teacher parents 100% said all the work done by home hence the time save and invest the time in any other activities. Increase computer literacy among students, parents, and teachers. Online education increase understanding because the teacher uses various techniques to reach knowledge to students and parents also involved in that. 100 % of all the respondents agree with the above points which shows the positive impact of COVID-19 on the education system.



**Table No. 2**  
**COVID-19 Negative Impact in education system**

Particular	Students	Parents	Teachers	Total	Percentages
Loss of education	50	50	50	150	100%
Campus recruitment stop	50	50	50	150	100%
Loss one on one interactive teaching	50	50	50	150	100%
Responsibility of parents is Increase to educate their students	50	50	50	150	100%
Problems in payment of fees	50	50	50	150	100%

(Source: Primary Data)

The above table shows the negative impact of COVID 19 on education. 100% of students, teachers, and parents said in the primary stage of COVID -19 lockdown the all the student's lost their education during the lockdown. 100% of respondent said Campus recruitment stop, loss one on one

interactive teaching, the responsibility of parents is increase to educate their student in the online education etc are the points badly effect on education system. Due to corona various families unable to paid the fees of school and colleges.

**Table No. 3**  
**Best education system**

Particular	Students	Parents	Teachers	Total	Percentages
Offline	41	46	50	137	91.33%
Online	9	4	00	13	8.66%

(Source: Primary Data)

The above table shows the highest 91.33% respondents are not happy with online education system. They said that our country is developing country. 364 million peoples are come under below poverty line. They can't afford technologies which required for online education. Most of the teacher and Parents are so far from digital education system hence it makes a limitation in reach education to students. Hence all the students, teacher and parents are not agreed with the online education system. Each and every child have right to take an education

hence this system is not useful. From the above table it shows that people show their interest in offline education they think face to face education help to understanding better concepts as well as teacher can constraint on each and every student. In online education system there are lots of problems such as slow internet connection, mobile and computer less literacy, poverty, less concept clarification, reduce hand writing practices etc. hence highest respondent like offline education system.

**Table No. 4**  
**Have you satisfied with government initiative?**

Particular	Students	Parents	Teachers	Total	Percentages
Yes	15	13	04	32	21.33%
No	35	37	46	118	78.66%

(Source: Primary Data)

The table shows that the people happy with government initiatives or not, we already discussed about government initiatives. But such as initiatives are not sufficient, respondent said. Hence most of the respondent very less happy with government initiatives. Government said to all colleges to start online lectures but student not attending classes as well as students are unhappy with online teaching and learning method, other side online examination but in the online examination mostly students do copy. Most of the universities and colleges take online entrance exam for the specific course in that

exam also students do copy hence universities and colleges take once again the entrance exam. We have not a good technology to handle this type of frauds. We are very years back to use technology in proper way. Indian government are far away from the vaccination in that situation other countries are get vaccinated. Government do not pay attention to the student and teachers' vaccination. For those reasons highest respondent is not happy with government initiatives.



**Table No. 5**  
**Total Covid Vaccination in India**

<b>Particular</b>	<b>Figure In Lakh</b>
<b>Total Vaccination Doses</b>	3165.60
<b>Dose 1 - Vaccination</b>	2617.27
<b>Dose 2 - Vaccination</b>	548.32
<b>Total Vaccinated Male</b>	1705.71
<b>Total Vaccinated Female</b>	1459.36

(Source: CoWin Portal)

The above table shows the total vaccination in has done in India. Keeping in view the above table it suggests very shortfall in vaccination. Government facing vaccine shortage. About 3% of India's population has been vaccinated. So far, people are still waiting for 2 doses of vaccine.

## 5. FINDINGS

Nelson Mandel said “Education is the powerful weapon which you can to change the world”, hence Every have to focus on the 100 % education to the youth in proper way. This epidemic situation very badly effects on education system. Government takes help of online education but this is totally failed initiatives. Hence from the above data research findings following points

1. As per table no. 1, Covid-19 has accelerated the adoption of digital technology for education. It encourages all teachers and students to acquire more knowledge of technology. New ways of sending and evaluating the study provided great opportunities for major changes in the field of curriculum development. In the lockdown situations, the students couldn't collect the hard copy of the study material and hence most of the students used the soft copy material for reference. There is a new opportunity where collaborative teaching and learning can take on new forms. There can also be collaboration between teachers around the world to benefit each other. The epidemic has led to a huge increase in opportunities for teleconferencing, virtual meetings, webinars and e-conferencing. The epidemic situation prompted people to learn and use digital technology and resulted in an increase in digital literacy. Teaching material is easily shared among students email, SMS, phone calls and various social media like WhatsApp. Students are managing their time in online education more efficiently. During the epidemic situation, most of the students preferred the Online and Distance Learning mode as it encourages self-learning to learn from various resources and provide customized learning opportunities as per their needs.
2. As per table no. 2, Classes have been closed and examinations at various levels have been postponed. Various boards have already postponed the annual examinations and entrance examinations. There was a delay in the admission process. this is going to worsen the continuity situation in education. With most of the recruitment postponed due to COVID-19, placements for students may also get affected as companies are delaying the onboarding of students. The unemployment rate is expected to rise due to this epidemic. In India, there is no recruitment in Govt. The sector and fresh graduates fear to withdraw their job offers from the private sector due to the current situation. During this lockdown, most of the parents will be facing unemployment and unemployment situations, so they may not be able to pay the fee for that particular time period which may affect the private institutions.
3. As per table no. 3, Not all teachers/students are good at it or at least they all were not ready for this sudden change from face-to-face learning to online learning. Some well-educated parents are able to guide but some do not have the level required to teach children at home. Since many students have limited or no internet access and many students may not be able to support computers or mobile phones in their homes, online teaching-learning can create a digital divide among students. The lockdown has hit the poor students in India very hard as most of them are unable to learn online as per various reports. The epidemic has affected the higher education sector significantly. A large number of Indian students who are enrolled in several universities abroad, especially in the worst-affected countries, are now leaving those countries and if the situation persists, in the long run, there will be a significant decline in the demand for international higher education.
4. As per table no. 4, Government initiatives is not enough in this epidemic. Government is failed to start offline education.





5. As per the table no. 5, Government has facing difficulty in vaccination to peoples due to shortage of covid vaccine.

## 6. SUGGESTIONS

1. India must develop creative strategies to ensure that all students have sustainable access to learning during the epidemic COVID-19. Indian policies must include diverse individuals from diverse backgrounds, including remote areas, marginalized and minority groups, for effective distribution.
2. Urgent changes are needed to reduce the impact of this epidemic on job offers, internship programs and research projects.
3. Many online learning platforms offer multiple programs on the same topic with different levels of certification, methodology and assessment parameters. Hence, the quality of programs may vary across different online learning platforms. Therefore, keeping in view the rapid growth of online learning platforms, quality assurance mechanisms and setting up of quality benchmarks for online learning programs should be developed and introduced by the Higher Education Institutions (HEIs) in India.
4. The government and educational institutions should plan to continue educational activities while maintaining social distancing. 40% to 50% of the students and teachers can attend the schools/colleges in two shifts per day to carry out the educational activities following the guidelines of COVID-19.
5. In the present times, technology and access to the Internet is an urgent need. Therefore, digital capabilities and the necessary infrastructure must reach remote and poorest communities to facilitate students to continue their education during the epidemic. Public funding needs to be deployed to address the lack of internet and for students to continue learning digitally. State governments/private organizations should come up with ideas to solve this issue of digital education.
6. Some of the important issues associated with distance education strategies are the availability and accessibility of digital devices with internet connectivity, the need for safe learning spaces, creating the ability for teachers, families and students to operate and navigate digital devices, and students with disabilities. Attractive lesson

plans for and other marginalized groups must be addressed by the government and stakeholders.

7. The government should focus on vaccination of students and teachers to start educational institutions.

## 7. REFERENCES

1. Pravat Ku. Jena 2020 a. *Challenges and Opportunities created by Covid-19 for ODL: A case study of IGNOU. International Journal for Innovative Research in Multidisciplinary Filed, Volume-6, Issue- 5, Pg. 217-222.*
2. *Study Abroad Life (2020). How Covid-19 will affect the Indian education system. Retrieved on May 25, 2020 from <https://www.studyabroadlife.org/how-covid-19-will-affect-the-indian-education-system/>*
3. Pravat Ku. Jena 2020 b. *Online learning during lockdown period for covid-19 in India. International Journal of Educational Research, Volume-9, Issue- 5(8), Pg.82-92.*
4. Kamlesh 2020, *Covid-19: 4 negative impacts and 4 opportunities created for education. Covid-19: 4 negative impacts and 4 opportunities created for education - Education Today News (indiatoday.in)*
5. *Wikipedia, COVID-19 epidemic in India, May 2020, [https://en.wikipedia.org/wiki/COVID-19\\_epidemic\\_in\\_India](https://en.wikipedia.org/wiki/COVID-19_epidemic_in_India).*
6. *<https://www.cowin.gov.in/home> , 27-06-2021,9:30 a.m.*
7. *<https://timesofindia.indiatimes.com/india/vaccination-graph-continues-to-dip-below-20-lakh-for-6th-day/articleshow/82781928.cms>*



# A SURVEY ON DATA ANALYSIS APPROACH FOR EFFECTIVE CONTAINMENT TOWARDS PANDEMIC INFECTIONS USING NEURAL NETWORKS

Anix Mary Javitha. A<sup>1</sup>, Dr, Mary Livinsa. Z<sup>2</sup>

<sup>1</sup>Research Scholar, Sathyabama Institute of Science and Technology, Chennai,  
<sup>2</sup>Associate Prof-ETCE, Sathyabama Institute of Science and Technology, Chennai

Article DOI: <https://doi.org/10.36713/epra7553>  
DOI No: 10.36713/epra7553

## ABSTRACT

*This Covid-19 is a new pandemic infectious era for our human life, in order to deal with it in proper manner, the necessity and importance of data analysis research reports, models, approaches are of the basic requirements for our sustainable, patience and stress less future. Neural network model organization and development with proper incorporation of pandemic condition parameters with maximum level of accuracy and efficiency are the main issues related with data analysis in pandemic infection containment. The implementation of neural networks techniques associated with data analysis approaches will be the best combination in this research area in near future.*

**KEYWORDS**— Neural networks, Covid-19, Pandemic, Data analysis, Containment.

## 1. INTRODUCTION

**Covid-19** -The new corona virus is a respiratory virus identified in 2019 which spreads primarily through droplets generated when an infected person coughs or sneezes, or through droplets of saliva or discharge from the nose.

**Prediction**-A prediction is what someone thinks will happen. A prediction is a forecast, but not only about the weather. Pre means “before” and diction has to do with talking. So a prediction is a statement about the future, based on facts or evidence.

**Data Analytics**-Data analysis is a process of inspecting, cleansing, transforming and modeling data with the goal of discovering useful information, informing conclusions and supporting decision-making.

**Neural Networks**-A neural network is a series of algorithms that endeavors to recognize underlying relationships in a set of data through a process that mimics the way the human brain operates. In this sense, neural networks refer to systems of neurons, either organic or artificial in nature.

**Supervised learning** -It is the machine learning task of learning a function that maps an input to an output based on example input-output pairs. It infers a function from labeled training data consisting of a set of training examples[9].

**Data Model**-A data model is an abstract model that organizes elements of data and standardizes how they relate to one another and to the properties of real-world entities.

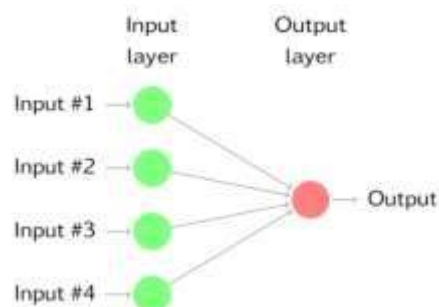


Fig-1:Neural Network Model

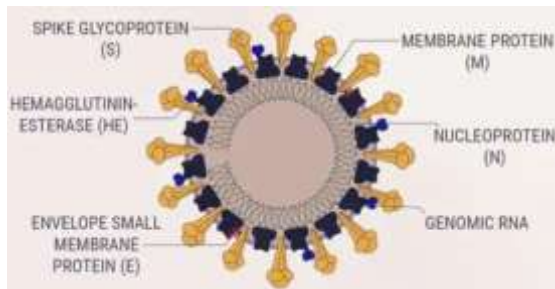


Fig-2: Covid-19 virus structure

## 2. DATA ANALYSIS APPROACHES

Data Analysis is an analytic process designed to explore data (usually large amounts of data typically business or market related) in search of consistent patterns and/or systematic relationships between variables, and then to validate the findings by applying the detected patterns to new subsets of data. The ultimate goal of data analysis is prediction - and predictive data analysis is the most common type of data exploration and one that has the most direct business applications. The process of data analysis consists of three stages: (1) the initial exploration, (2) model building or pattern identification with validation/verification, and (3) deployment (i.e., the application of the model to new data in order to generate predictions) [8].

1. Data Mining
2. Crucial Concepts in Data Mining
3. Data Warehousing
4. On-Line Analytic Processing (OLAP)
5. Exploratory Data Analysis (EDA) and Data Mining Techniques
  - a. EDA vs. Hypothesis Testing
  - b. Computational EDA Techniques
  - c. Graphical (data visualization) EDA techniques
  - d. Verification of results of EDA
6. Neural networks

## 3. APPROACHES OF NEURAL NETWORKS

Neural networks, with their remarkable ability to derive meaning from complicated or imprecise data, can be used to extract patterns and detect trends that are too complex to be noticed by either humans or other computer techniques. A trained neural network can be thought of as an "expert" in the category of information it has been given to analyze. This expert can then be used to provide projections given new situations of interest and answer "what if" questions. Other advantages include:

1. Adaptive learning: An ability to learn how to do tasks based on the data given for training or initial experience.

2. Self-Organization: An NEURAL NETWORK can create its own organization or representation of the information it receives during learning time.
3. Real Time Operation: NEURAL NETWORK computations may be carried out in parallel, and special hardware devices are being designed and manufactured which take advantage of this capability.
4. Fault Tolerance via Redundant Information Coding: Partial destruction of a network leads to the corresponding degradation of performance. However, some network capabilities may be retained even with major network damage.

## 4. COVID-19 PANDEMIC SCENARIO

Corona virus disease (COVID-19) is an infectious disease caused by a newly discovered corona virus.

Most people infected with the COVID-19 virus will experience mild to moderate respiratory illness and recover without requiring special treatment. Older people and those with underlying medical problems like cardiovascular disease, diabetes, chronic respiratory disease, and cancer are more likely to develop serious illness [10].

The best way to prevent and slow down transmission is to be well informed about the COVID-19 virus, the disease it causes and how it spreads. Protect yourself and others from infection by washing your hands or using an alcohol based rub frequently and not touching your face.

The COVID-19 virus spreads primarily through droplets of saliva or discharge from the nose when an infected person coughs or sneezes, so it's important that you also practice respiratory etiquette (for example, by coughing into a flexed elbow).

## 5. LITERATURE SURVEY ON NEURAL NETWORK ON COVID-19

- Huang C, Wang Y, Li X, et al. "Clinical features of patients infected with 2019 novel coronavirus in Wuhan, China". Lancet 2020 describes Coronaviruses (CoV) belong to the genus Coronavirus in the Coronaviridae. All CoVs are pleomorphic RNA viruses characteristically containing crown-shape peplomers with 80-160 nM in size and 27-32 kb positive polarity. With its high mutation rate, Coronaviruses are zoonotic pathogens that are present in humans and various animals with a wide range of clinical features from asymptomatic course to requirement of hospitalization in the



intensive care unit; causing infections in respiratory, gastrointestinal, hepatic and neurologic systems.

- Nada Elgendy et al “Data Analytics” describes in the information era, enormous amounts of data have become available on hand to decision makers. Big data refers to datasets that are not only big, but also high in variety and velocity, which makes them difficult to handle using traditional tools and techniques. Due to the rapid growth of such data, solutions need to be studied and provided in order to handle and extract value and knowledge from these datasets. Furthermore, decision makers need to be able to gain valuable insights from such varied and rapidly changing data, ranging from daily transactions to customer interactions and social network data.
- Gail Brion et al “**Neural Network Prediction of Viruses in Shellfish**” describes A database was probed with neural network and multivariate logistic regression (MLR) models to investigate the efficacy of predicting PCR-identified human adenovirus (ADV), Norwalk-like virus (NLV), and enter virus (EV) presence or absence in shellfish harvested from diverse countries in Europe (Spain, Sweden, Greece, and the United Kingdom). The relative importance of numerical and heuristic input variables to the ANN model for each country and for the combined data was analyzed with a newly defined relative strength effect, which illuminated the importance of bacteriophages as potential viral indicators.
- The huge impact of Covid-19 pandemic virus spread is collected from <https://www.worldometers.info/coronavirus/#countries>.

## 6. CHALLENGES IN COVID-19 DATA ANALYTICS

Searching for relevant information sources

We are witnessing tremendous growth of articles published on this topic, already counting in thousands. For methodologists and researchers in the field of evidence synthesis, the challenge will be searching for the relevant information sources. Creating specialized, publicly accessible collection

of studies with original studies about COVID-19 can surely help in this. For example, WHO has set up a collection of articles about COVID-19, compiled in a publicly available database? On March 30, 2020 this database had already included 3294 articles.

Synthesizing evidence rapidly

In a world where each day brings hundreds of new articles on a hot topic, conducting evidence synthesis will be particularly challenging. Systematic reviews are considered by many as the highest-level of evidence in the hierarchy of evidence in medicine, but their production often takes years [7]. However, multiple systematic reviews about COVID-19 have already been published. It remains to be seen what the quality of those rapidly produced systematic reviews is.

Data sharing

To enable analysis of data gathered during COVID-19 pandemic, principles of open science and raw data sharing will be of utmost importance. Global norms have been proposed [3] for data sharing during global health emergencies, and it remains to be seen whether researchers will be more likely to share their raw data publicly in articles covering COVID-19.

In conclusion, there are many methodological challenges related to producing, gathering, analyzing, reporting and publishing data in condensed timelines required during a pandemic.

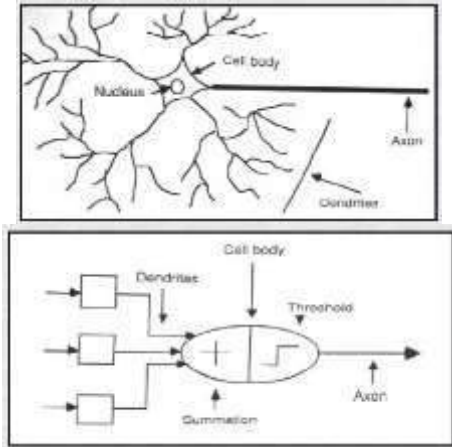
## 7. NEURAL NETWORK DATA IMPLEMENTATION

Neural networks and conventional algorithmic computers are not in competition but complement each other. There are tasks more suited to an algorithmic approach like arithmetic operations and tasks that are more suited to neural networks. Even more, a large number of tasks, require systems that use a combination of the two approaches (normally a conventional computer is used to supervise the Neural network) in order to perform at maximum efficiency.

Much is still unknown about how the brain trains itself to process information, so theories abound. In the human brain, a typical neuron collects signals from others through a host of fine structures called dendrites. The neuron sends out spikes of electrical activity through a long, thin stand known as an axon, which splits into thousands of branches. At the end of each branch, a structure called a synapse converts the activity from the axon into electrical effects that inhibit or excite activity from the axon into electrical effects that inhibit or excite activity in the connected neurons. When a neuron receives excitatory input that is sufficiently large compared with its

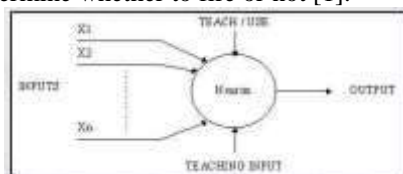


inhibitory input, it sends a spike of electrical activity down its axon. Learning occurs by changing the effectiveness of the synapses so that the influence of one neuron on another changes.



**Fig-3: Artificial Neurons**

An artificial neuron is a device with many inputs and one output. The neuron has two modes of operation; the training mode and the using mode. In the training mode, the neuron can be trained to fire (or not), for particular input patterns. In the using mode, when a taught input pattern is detected at the input, its associated output becomes the current output. If the input pattern does not belong in the taught list of input patterns, the firing rule is used to determine whether to fire or not [1].



**Fig-4: Training Node concept**

The firing rule is an important concept in neural networks and accounts for their high flexibility. A firing rule determines how one calculates whether a neuron should fire for any input pattern. It relates to all the input patterns, not only the ones on which the node was trained. A simple firing rule can be implemented by using Hamming distance technique.

### 8. NEURAL NETWORKS TOOLS PERFORMANCE

The following table-1 illustrates the neural network tools with its implementation scope for covid-19 data analytics.

**Table-1: Neural n/w Tools for data analysis**

Sl.No	Software Tool name
1	Neural Designer
2	Neuroph, Darknet
3	Keras
4	NeuroSolutions

5	Tflearn
6	ConvNetJS
7	Torch
8	NVIDIA DIGITS
9	Stuttgart NN Simulator
10	DeepPy
11	MLPNeuralNet
12	DNNGraph
13	AForge.Neuro
14	NeuralN
15	NeuralTalk2
16	Knet
17	cuda-convnet2
18	DN2A
19	Mocha
20	HNN Lasagne neon
21	LambdaNet
22	gobrain
23	RustNN
24	deeplearn-rs

### 9. NEURAL NETWORKS IN MEDICINE

Neural networks are currently a 'hot' research area in medicine and it is believed that they will receive extensive application to biomedical systems in the next few years including Covid-19 with its mutations. At the moment, the research is mostly on modeling parts of the human body and recognizing diseases from various scans (e.g. cardiograms, CAT scans, ultrasonic scans, etc.) [4].

Neural networks are ideal in recognizing diseases using scans since there is no need to provide a specific algorithm on how to identify the disease. Neural networks learn by example so the details of how to recognize the disease are not needed. What is needed is a set of examples that are representative of all the variations of the disease. The quantity of examples is not as important as the 'quantity'. The examples need to be selected very carefully if the system is to perform reliably and efficiently [5].

### 10. APPLICATIONS OF NEURAL NETWORKS

1. Neural networks are best at identifying patterns or trends in data, they are well suited for prediction or forecasting needs including [6]:

- Sales forecasting
- Industrial process control
- Customer research
- Data validation
- Risk management
- Target marketing
- Pandemic data analysis and prediction





Neural Networks is also used in the following specific paradigms: recognition of speakers in communications; diagnosis of hepatitis; recovery of telecommunications from faulty software; interpretation of multi meaning Chinese words; undersea mine detection; texture analysis; three-dimensional object recognition; hand-written word recognition; and facial recognition and pandemic disease data analysis and prediction.

## 11. CONCLUSION

Neural network in information technology enhances the information provided on utility sites to be structured. This allows for a pandemic infection data analysis of the covid-19 Web data domains to access specific information without having to search the entire site. With the use of this type of data analysis, data remains available through order of relativity to the query, thus providing productive information for predicting the impacts and make us alert to avoid certain vulnerable conditions. The main purpose of neural network data analytic is to gather, organize, categorize and provide the user with the best possible information that is available on World Wide Web. This paper has discussed about the research issues in neural network based covid-19 analytics possibility and also provided detailed review about the basic concepts of data analysis, neural networks and covid-19 scenario. Several open research issues and drawbacks which are exists in the current techniques are also discussed. This study and review would be helpful for researchers those who are doing their research in the domain of neural networks. The future scope of neural networks is to predict the user needs to improve the usability and scalability.

## REFERENCES

1. Woo PC, Huang Y, Lau SK, Yuen KY. Corona virus genomics and bioinformatics analysis. *Viruses* 2010;18–20.
2. Drexler JF, Gloze-Rausch F, Glenda J, Cormen VM, MuthD, Goettsche M, et al. Genomic characterization of severe acute respiratory syndrome-related corona virus in European bats and classification of corona viruses based on partial RNA-dependent RNA polymerase gene sequences. *J Virol* 2010; 84:11336–49.
2. Yin Y, Wunderkindk RG. MERS, SARS and other corona viruses as causes of pneumonia. *Respirology* 2018; 23:130–7.
3. Peiris JSM, Lai ST, Poona L, et al. Corona virus as a possible cause of severe acute respiratory syndrome. *The Lancet* 2003; 361:1319–25.
4. Zaki AM, van Boheemen S, Bestebroer TM, Osterhaus AD, Fouchier RA. Isolation of a novel corona virus from a man with pneumonia in Saudi Arabia. *N Engl J Med* 2012; 367:1814–20.
5. Seven days in medicine: 8-14 Jan 2020. *BMJ* 2020; 368:m132.31948945.
6. Imperial College London. Report 2: estimating the potential total number of novel corona virus cases in Wuhan City, China. Jan 2020. <https://www.imperial.ac.uk/mrc-globalinfectiousdisease-analysis/news--wuhan-coronavirus>.
7. European Centre for Disease Prevention and Control data. Geographical distribution of 2019- nova cases. Available online :( <https://www.ecdc.europa.eu/en/geographical-distribution-2019-ncov-cases>) (accessed on 05 February 2020)
8. World Health Organization, 2019- nCoV Situation Report-22 on 12 February, 2020. <https://www.who.int/docs/defaultsource/coronaviruse/situation-reports/>
9. Gralinski L, Menachery V. Return of the Corona virus: 2019-nCoV, *Viruses* 2020.



## CHILD WELFARE: A REVIEW BASED ON SOCIAL DEVELOPMENT PERSPECTIVE

**Ishita Kapur**

*Masters in Social Work, Jamia Millia Islamia, New Delhi*

Article DOI: <https://doi.org/10.36713/epra7527>

DOI No: 10.36713/epra7527

### ABSTRACT

*The article explains why enhancing educational equity and minimising school failure are cost-effective, especially in light of the current economic crisis. Children are harmed by inequitable education policies and practices, which also impede economic and social progress. The importance of school in the lives of children is discussed. It is argued that school has the potential to be an ally for children, a provider of basic protection, a capacity builder, a safe base from which to explore oneself and the world, an integrator into community and culture, a gateway to opportunities, and a resource for parents and communities. It emphasises the importance of investing early in all children, particularly those from underprivileged backgrounds, and supporting them through upper secondary school, particularly in times of fiscal difficulties. Reduced school dropout benefits both society and individuals. It can also help with economic development and social development. Indeed, the most successful education systems in the world are those that combine quality with equity. In education, equity means that personal or societal conditions, such as gender, ethnic origin, or family background, are not impediments to realising educational potential, and that all students attain a basic minimum level of abilities.*

**KEY WORDS;** *social work, school, children, child and family social work*

### INTRODUCTION

Education systems that mix equity and excellence have the best results. They provide all children with the opportunity to receive a high-quality education. A child's failure in school has long-term consequences. A child who drops out of school without completing upper secondary education or possessing the necessary abilities has fewer opportunities in life. The same child is also less likely to pursue additional education and is less capable of fully participating in civic and democratic components of modern society. Lower starting and lifetime incomes, more difficulty adapting to fast changing knowledge-based economies, and higher unemployment risks are all signs of this. National educational policies appear to receive little attention in social work education or research. Educational failure also has a high societal cost. People with a low level of education impede an economy's ability to create, grow, and innovate. School failure harms social cohesion and mobility, as well as imposing additional expenses on government budgets to deal with the repercussions - higher public health and social assistance spending, as well as increased

criminality, to name a few. This article seeks to examine common neglect of school as a powerful institution in the social development and protection of children worldwide. Various roles that schools can play in young people's social development are conceptualised and discussed. Furthermore, the specific contribution that schools can make to vulnerable groups of children is taken into account.

Children's life chances are strongly influenced by the quality of their education. Schools aim at providing children with knowledge, skills and interpersonal competences required for their development, adult life and contributions to economy and society. Schools can offer learning experiences that a child may not obtain at home, particularly if he or she is living in a disadvantaged environment (Heckman, 2011). However despite efforts by governments to provide high quality education, significant disparities in educational outcomes continue to exist. A large number of students fail to obtain a minimum level of education, jeopardising their own future and the progress of their society (Publishing, 2012).



The arguments in my paper are derived from my reading of literature:

1. A school must stimulate curiosity in the young, impressionable minds and equip them with tools to be better human beings (Sharma, 2021).
2. School must be seen as a potentially key preventive and protective resource for children experiencing social adversity, since the positive effects of school experience seem most evident or potent among students who are vulnerable (Rutter, 2009).
3. Teachers are the professionals who have the most contact with children and thus must be understood by other child-focused professionals.
4. Resources to assist children and families experiencing adversity are difficult to generate, in terms of both finding additional resources and avoiding stigma. Strengths perspective reminds us to look for resources in unlikely places. Even the harsh local environment may also be 'a lush topography of resources' (Saleebey, 2006).
5. Schools also must be involved in working to prevent maltreatment from ever occurring at all. Schools are in a unique position to address this problem by virtue of the staff's training and expertise, the school's position in the community, and the availability of physical facilities (Crosson-Tower, 2003).
6. The fact that some schools or teachers may fail due to a lack of resources, policy, governance, support, training, or the socioeconomic foundation of their host community does not preclude schools from succeeding in the face of adversity. Any disillusionment with schools or teachers resulting from negative personal or professional experiences with schools, or even philosophical reservations about schooling, should not obscure the school's normalising potential as a social institution, especially for children who do not have other non-stigmatizing sources of support, social inclusion, and encouragement in their lives.

## THE VALUE OF SCHOOLING IN CHILD WELFARE

In this section, it is argued that schools play, or have the potential to play, a number of important roles in the social development of their students under the right conditions. These roles are classified under several headings.

**Strengthen School leadership:** School leadership is the starting point for the transformation of low performing disadvantaged schools but often, school

leaders are not well selected, prepared or supported to exercise their roles in these schools. To strengthen their capacity, school leadership preparation programmes should provide both general expertise and specialised knowledge to handle the challenges of these schools (Publishing, 2012). Findings from a recent British study of teenagers' experiences of social work and related services suggest that, for some young social work clients at least, teachers may be preferred to social workers as confidants (Triseliotis, 2011).

**School with efficient teachers:** The educator has a vital role in identifying, reporting, and preventing child abuse and neglect. There are many reasons why educators are so vital in identifying, treating, and preventing child maltreatment. First, they have close and consistent contact with children. Second, educators have a professional and legally mandated responsibility for reporting suspected maltreatment. Third, school personnel have a unique opportunity to advocate for children, as well as provide programs and services that can help children and strengthen families (Crosson-Tower, 2003). It can be concluded that school welfare provision will positively influence teacher performance if teachers are reciprocally committed to work while at the same time administrators meet teachers varied needs. This argument is in support of Vroom's Expectancy Theory as the theoretical lens for the study. The theory emphasizes that people join organizations with expectations about fulfilment of their needs and motivations. In the process, they also have to satisfy the organization's goals (Lunenburg, 2011). The needs and motivations represent people's social welfare (Naluwemba Frances, 2016).

**School with a facilitative learning environment:** Appearance, behaviour, performance, time-keeping, parental contact, and travel to and from school can all provide clues to alert teachers about the child's social life both inside and outside the school gates. When the school's threshold of concern is crossed, vigilance and action on the part of the school can initiate the process of assistance. Schools can advocate for students to address any difficulties they may be experiencing as victims or as risk takers. Schools lend their voice to a child in need (O'Moore, 2007).

**School with supportive structures for children:** Schools provide children with opportunities to build their self-esteem (Brooks, 1994). High expectations of their students imply that the school believe in the innate capacity of the young person. Such high expectations can help to promote resilience (Benard, 1991). School structures, resources and practices also matter greatly. The way learning is delivered, extra-curricular activities, discipline, relations with peers



and teachers and some pedagogic practices have a strong impact on students' learning, motivation and sense of belonging (Publishing, 2012). In the case of risk behaviours such as drug abuse, there is some evidence that well-constructed school-based life skills training programmes may have an impact in reducing subsequent drug use (Gilbert J. Botvin, 1995). It seems that positive school experience may also foster in quite a central way a sense of self-efficacy. In the long run, the effects of school may be less to what children are actually taught than to the school's impact on children's attitudes to learning (Rutter, 2009).

***School as a place for quality education of children:***

School is a place for a child experiencing typical developmental possibilities to acquire confidence and social belonging, to practise adult identities, and to investigate oneself and the environment. The supportive school, in the view of a Dutch observer 'presents a secure space for students who experience being respected as persons that stimulates their intellectual and emotional possibilities' (Katz, 2003). Within a positive school ethos, teachers can come to recognize the classroom and the school as 'a symbolic and sanctuary for the vulnerable child' (Crosson-Tower, 2003).

***School with a link to parents and communities:***

Disadvantaged parents tend to be less involved in their children's schooling, for multiple economic and social reasons. Engaged parents encourage more positive attitudes towards school, improve homework habits, reduce absenteeism, disengagement and dropout and enhance academic achievement. Policies need to be designed to ensure that disadvantaged schools prioritise their links with parents and communities, building the capacity to: a) Improve and diversify communication strategies to align school and parental efforts. The more effective strategies target parents who are more difficult to reach and provide them with clear guidelines on how to best support their children. b) Identify and encourage individuals from the same communities to mentor students from disadvantaged schools and support their learning. This can be particularly effective in improving schooling outcomes. Links can also be built with local stakeholders, such as the business community (Publishing, 2012).

***School as a resource to parents and communities:***

Parents and community members as supporters and advocates for the education of their children are facilitated through site-based school restructuring. Restructuring schools to create parent and community partnerships with schools focuses on organizational structure. Changing activities; creating new relationships between parents, families,

communities, and schools; and implementing innovative strategies are ways that schools can restructure to facilitate parent and community involvement in this role. Parents and community members as participants in the education of all children incorporate a broader vision in the partnership between schools and the populations they serve. District wide programs provide the vehicle for parents and community members to be involved in roles that reach beyond the immediate impact of an individual child to the impact on all children in the district (Barry Rutherford, 1995).

**THE ROLE OF SCHOOLS TO TACKLE ISSUES THAT HINDER WELFARE OF CHILDREN**

We can never equalise all of the factors that influence achievement and personal success. However, we can invest wisely to address disparities that cause large and persistent problems that endanger our children's well-being. Across socioeconomic groups, gaps in capabilities that play important roles in determining diverse adult outcomes emerge early. The gaps begin before formal schooling and continue throughout childhood and into adulthood. Resolving problems caused by gaps is more expensive than preventing them in the first place.

***Help Children who need care and supervision***

In their study of teenagers with social workers, Triseliotis et al. (1995) found that 'a view of self and comparatively favourable educational progress seemed to be important factors in negotiating the problem' (Triseliotis, Teenagers and the Social Work Services, 2011).

There is evidence that school may influence outcomes for children. A Danish follow-up study of adults in care found that school experiences have been an important factor for those who had done reasonably well despite adversity. One study has found that the prospects for placement stability were enhanced where the child did not change school when moving into the foster home (Clever, 2010).

***Assist children who are at risk of becoming delinquent***

Children showing persistent disruptive behaviour are likely to become child delinquents and, in turn, child delinquents are likely to become serious, violent, or chronic juvenile offenders. Understanding the early emergence of problem behaviours may help in the creation of earlier, effective interventions for the prevention of child delinquency (Rolf Loeber, 2003).

A review of effective approaches to prevention found that good quality programmes and school environment and practices had a bearing on the path





which a vulnerable youngster would follow (Yoshikawa, 1994). Studies addressing school influences on antisocial behaviour have consistently shown that poor academic performance is related to child behaviour problems and to the prevalence, onset, and seriousness of delinquency (Rolf Loeber, 2003).

#### ***Children who are facing emotional or behavioural issues***

Schools may also influence favourably the level of emotional problems. Research findings suggest that the school factors which promote positive behaviour include: 'high expectations for work and behaviour, models of behaviour, a respect for children, opportunities for children to be involved in the school, encouragement of good behaviour, pleasant working conditions, good teacher-child relationships (Cox, 2018). Of all known interventions to reduce juvenile delinquency, preventive interventions that focus on child delinquency will probably take the largest "bite" out of crime. Specifically, these efforts should be directed first at the prevention of persistent disruptive behaviour in children in general; second, at the prevention of child delinquency, particularly among disruptive children; and third, at the prevention of serious and violent juvenile offending, particularly among child delinquents (Rolf Loeber, 2003).

#### ***Children of divorced parents***

American researchers have found that attention from teachers were associated with positive adjustment by the child after parental divorce (Cox, 2018). In one large American study it was found that students who had experienced parental divorce benefited from an authoritative school climate which 'provided an organized, environment with clearly defined enforced standards, expectations for appropriately mature, responsible behaviour. These benefits of the school were marked for children who had experienced parental divorce, high levels of conflict, or high levels of stressful life events' (Hetherington, 1993).

#### ***Children who have been abused or neglected***

Relationships with teachers may help people compensate for lack of supportive relationships in their lives (J.Galbo, 1986). The teacher may be able, for instance, help child recover from or cope with a stressful experience such as sexual abuse by gradually helping the child to rebuild self- confidence coping with stress (Maggie Robson, 1995).

The protection of children is not only an individual issue, but a community concern as well. Educators are an integral part of the community and, as such, can lead and be involved in community

efforts to combat child maltreatment (Crosson-Tower, 2003).

#### ***Children from economically disadvantaged families***

School experiences may serve as some of the worst effects of socio-economic disadvantage. The interest of teachers and other school staff may prove very beneficial. Researchers in one study found that 'for students who experience one or more conditions of disadvantage, support received from school was associated with positive academic outcomes' (DuBois DL, 1994).

### **CONSEQUENCES FOR CHILD AND FAMILY SOCIAL WORK**

While child protection is likely to have raised the profile of teachers and schools in the minds of many social workers, it is critical that they recognise that teachers and schools play a larger role in the social development of children than a brief cameo in the opening scenes of any child protection drama.

If the task is to broaden our appreciation of the role of schools and teachers, there is a parallel need to expand our conception of what social work can contribute. The challenge is to develop context and appropriate models of social work in support of the tasks of teachers, children, parents and community (Openshaw, 2008). Because social workers and teachers are unable to assist children in need, alternative views of what is possible become even more crucial. Otherwise, many countries' children, parents, professions, and citizens may succumb to the "inevitability" of the status quo. Where they occur, poorly run schools, oppressive behaviour by teachers or students, poor interaction with parents, and poor relations amongst groups of professionals are not unavoidable. They result from policy, governance, and resource allocation decisions made by those in positions of authority. Challenging the harmful consequences of such decisions necessitates the involvement of a variety of stakeholders in the educational system, including, as this article argues, social workers and social services. Now, specific ways in which social workers might assist in the development of new possibilities are being investigated;

#### ***The provision of counseling for children***

School counselors provide counseling and guidance for students. They assist students with academic and personal problems to help them succeed in school. Many middle and high school counselors also help students plan their schedule of classes. Counselors for students in the higher grades help students plan for careers and higher education (Openshaw, 2008).





In particular, they must recognize the value of education and the school for youngsters in terms of their educational and social development and conversely the risks posed by educational failure (Milner, 2016).

Matters such as homework, adjustment to new schools and the other paraphernalia of school life require more attention. Two specific forms of intervention may be worthy of social work and support: helping children with reading difficulties, and after school study support schemes (Menmuir, 2006).

### ***Rationale behind involving teachers for child welfare***

The importance of the teacher's professional involvement in the welfare of children must be recognised by social workers. Engaging effectively with teachers and schools must also be considered a vital professional responsibility in child-centred social work. It is critical for non-teachers to understand the hard realities of life in the classroom while engaging with them and forming professional partnerships with them. Non-school professionals must be aware of the cost to teachers of intimate exposure to the raw facts of abuse or other difficulties in children's lives, as well as the personal and professional ramifications of such exposure (Kelly, 1980).

In the absence of proper specialised training or support, the thought of a lifetime of teaching in a community trapped in persistent poverty can deplete morale and tolerance. Teachers may feel compelled to use tactics that are ultimately ineffective in terms of student motivation and achievement, as well as the teachers' own pleasure. However, it is a disservice to children to expect or claim too much for the role of teachers at times of crisis in a child's life. The problems at home may not be known to teachers or they may be too great for teachers to be able to engage with them (Kelly, 1980).

Teachers who are well equipped with knowledge, skills and positive attitudes (Walsh, Rassafiani, Mathews, Farrell, & Butler, 2010) can respond and assist maltreated children, including those who have been multiply victimized, by enhancing their learning potential and assuring their future safety. The second reason for locating child protection in pre-service teacher education relates to teachers' legal duties to report child abuse and neglect (Kerryann Walsh, 2011).

### ***Collaboration with the rest of the school and community***

Social workers and their organisations must acknowledge social work as a discipline with a knowledge base and level of expertise relevant to (1) the development of individual schools and the school

system as a whole, and (2) the school's deeper integration into community, professional, and children's services networks. School social workers assist children so they can be successful in school. The goal of school social work should be to give all children the opportunity and resources to help them succeed academically and socially in a safe and healthy school environment.

Social work in a public school setting plays a vital role in developing students and linking them to the resources and support necessary to maximize their potential in the educational process (Julie O'Donnell Ph.D., 1995). School social work is one of the most rewarding and interesting areas of social work practice. School social workers can have a life changing impact on their young clients in a way that those who work with adults rarely experience (Openshaw, 2008). Therefore, social workers and the organisations that employ them must be at the forefront of initiatives aimed at improving communities, schools, and, ultimately, the environment in which children grow up.

### ***Integration of Schools with social work***

As previously stated, social workers can only properly respond to the aforementioned exhortations if they are supported by suitable policies and resource allocation within each country's community services and educational systems. However, progress on this front requires a belief among child and family social workers that the school-social work link is part of their "core business." As a result, it appears critical that education and school concerns be prioritised considerably higher on the professional agenda of social work in terms of educational and training curriculum as well as professional supervision. Instead of seeing schools as a possible source of additional pressures and demands that cannot be met, social workers must be encouraged to see them as potentially effective allies in their work with children. Social workers must understand the consequences of (1) educational success or failure for their child clients, as well as (2) the larger social worth of school experience.

Collectively and individually, social workers in the child welfare field must see it as part of their professional mandate to participate in debates and policies affecting schools, with a particular focus on how well schools are resourced to work with vulnerable children and in high-risk communities. Their education must instil in them a sense of respect for the teacher's role and an understanding of the pressures that come with it. Individual teacher or school failures should not overshadow the good impact of schools and instructors on children's lives. It seems reasonable to hope that more satisfying professional roles for those involved, more integrated



support for individual children, and new models of provision better geared to the social and developmental needs of vulnerable children and young people will result from such joint training and closer professional cooperation.

## REFERENCES

1. Allen-Meaers, P. (1994). *Social Work Services in Schools: A National Study of Entry-Level Tasks*. Oxford Academic.
2. Barry Rutherford, B. A. (1995). *The Development and Implementation Of Parent and Community Involvement Programs*. *Studies of Education Reform: Parent and Community Involvement in Education*. Retrieved from [www2.ed.gov](http://www2.ed.gov): <https://www2.ed.gov/pubs/SER/ParentComm/cha p3.html>
3. Benard, B. (1991, August). *Fostering Resiliency in Kids: Protective Factors in the Family, School, and Community*. Retrieved from [files.eric.ed.gov](http://files.eric.ed.gov): <https://files.eric.ed.gov/fulltext/ED335781.pdf>
4. Brooks, R. B. (1994). *Children at risk: Fostering resilience and hope*. *American Journal of Orthopsychiatry*.
5. Cleaver, D. B. (2010). *Foster Home Breakdown*. *The Therapeutic Care Journal*. Retrieved from <https://thetcj.org/>: <https://thetcj.org/child-care-history-policy/foster-home-breakdown-by-david-berridge-and-hedy-cleaver>
6. Cox, A. (2018, January). *Befriending Young Mothers*. Retrieved from [www.cambridge.org](http://www.cambridge.org): <https://www.cambridge.org/core/journals/the-british-journal-of-psychiatry/article/abs/befriending-young-mothers/360A0927863ACAB4AA4BD41BBF7F2D40>
7. Crosson-Tower, C. (2003). *The Role of Educators in Preventing and Responding to Child Abuse and Neglect*. Retrieved from [www.childwelfare.gov](http://www.childwelfare.gov): <https://www.childwelfare.gov/pubPDFs/educator.pdf>
8. Dryfoos, J. G. (1994). *Full service schools: A revolution in health and social services for children, youth, and families*. San Francisco: Jossey-Bass. Wiley Online Library.
9. DuBois DL, F. R. (1994). *Prospective investigation of the effects of socioeconomic disadvantage, life stress, and social support on early adolescent adjustment*. *Journal of Abnormal Psychology*.
10. Gilbert J. Botvin, S. P. (1995). *Drug Abuse Prevention with Multiethnic Youth*. SAGE Publishing.
11. Heckman, J. J. (2011). *The Economics of Inequality*. Retrieved from [files.eric.ed.gov](http://files.eric.ed.gov): <https://files.eric.ed.gov/fulltext/EJ920516.pdf>
12. Hetherington, E. M. (1993). *An overview of the Virginia Longitudinal Study of Divorce and Remarriage with a focus on early adolescence*. SEMANTIC SCHOLAR.
13. J.Galbo, J. (1986). *Adolescents' perceptions of significant adults: Implications for the Family, the School and Youth Serving Agencies*. ScienceDirect.
14. Julie O'Donnell Ph.D., J. D. (1995). *Preventing School Failure, Drug Use, and Delinquency among Low-Income Children: Long-Term Intervention in Elementary Schools*. *American Journal of Orthopsychiatry*.
15. Katz, Y. J. (2003). *The use of virtual reality three-dimensional simulation technology in nursery school teacher training for the understanding of children's cognitive perceptions*. Springer Link.
16. Kelly, J. S. (1980). *Surviving the breakup: How children and parents cope with divorce*. SpringerLink.
17. Kerryann Walsh, L. L. (2011). *Locating child protection in preservice teacher education*. *Australian Journal of Teacher Education*, 33. Retrieved from [files.eric.ed.gov](http://files.eric.ed.gov): <https://files.eric.ed.gov/fulltext/EJ936998.pdf>
18. Maggie Robson, P. C. (1995). *Helping Children Manage Stress*. *British Educational Research Journal*.
19. Menmuir, R. (2006, August). *Involving Residential Social Workers and Foster Carers in Reading with Young People in Their Care: the PRAISE reading project*. Retrieved from [www.tandfonline.com](http://www.tandfonline.com): <https://www.tandfonline.com/doi/abs/10.1080/0305498940200306>
20. Milner, E. B. (2016, February). *Exclusion from School: Inter-Professional Issues for Policy and Practice*. Retrieved from [www.cambridge.org](http://www.cambridge.org): <https://www.cambridge.org/core/journals/journal-of-psychologists-and-counsellors-in-schools/article/abs/exclusion-from-school-interprofessional-issues-for-policy-and-practice-e-blyth-j-milner-eds-london-routledge-1996/B00009D80595318A9EA3695E51731A9C>
21. Naluwemba Frances, S. D. (2016). *The interplay of school welfare provision and teacherperformance: The case of Ugandan secondary schools*. Retrieved from [files.eric.ed.gov](http://files.eric.ed.gov): <https://files.eric.ed.gov/fulltext/ED578105.pdf>
22. O'Moore, M. (2007). *Bullying Behaviour in Children and Adolescents in Ireland*. Wiley Online Library.
23. Openshaw, L. (2008). *The Role and Function of the School Social Worker*. *Social Work in Schools: Principles and Practice*.
24. Publishing, O. (2012). *Equity and Quality in Education*. Retrieved from [www.oecd.org](http://www.oecd.org): <https://www.oecd.org/education/school/50293148.pdf>
25. Rolf Loeber, D. P. (2003, May). *Child Delinquency: Early Intervention and Prevention*. Retrieved from [www.ojp.gov](http://www.ojp.gov): <https://www.ojp.gov/pdffiles1/ojdp/186162.pdf>
26. Rutter, M. (2009, July 28). *Pathways from Childhood to Adult Life; The Role of Schooling*. Retrieved from [www.tandfonline.com](http://www.tandfonline.com).
27. Saleebey, D. (2006). *Strengths Perspective in Social Work Practice*, 4/e. Allyn & Bacon/Longman.



28. Sharma, D. (2021). *The importance of school education in child development*. Retrieved from [www.educationworld.in](http://www.educationworld.in):  
<https://www.educationworld.in/the-importance-of-school-education-in-child-development/>
29. Triseliotis, J. (2011, December). *Teenagers and the Social Work Services*. Retrieved from [thetcj.org](http://thetcj.org): <https://thetcj.org/child-care-history-policy/teenagers-and-the-social-work-services-by-john-triseliotis>
30. Triseliotis, J. (2011). *Teenagers and the Social Work Services*. *The Therapeutic Care Journal*.
31. Werner, E. E., & Smith, R. S. (1992). *Overcoming the Odds: High Risk Children from Birth to Adulthood*. Retrieved from [eric.ed.gov](http://eric.ed.gov).
32. Yoshikawa, H. (1994, January). *Prevention as cumulative protection: effects of early family support and education on chronic delinquency and its risks*. Retrieved from [pubmed.ncbi.nlm.nih.gov](http://pubmed.ncbi.nlm.nih.gov):  
<https://pubmed.ncbi.nlm.nih.gov/8310099/>



# An Anthropological Approach to the Use of Medicinal Plants in the Treatment of Diseases: The Case of King Grass (*Ageratum Conyzoides*) in Batibo Subdivision in North West Region of Cameroon

<sup>1</sup>Mukum Cenotar Engwari, <sup>2</sup>Ngoe Fritz Eseokwea (PhD),

<sup>3</sup>Achu Frida Njiei (PhD)

<sup>1</sup>Anthropologist/Researcher, National Centre for Education,  
Ministry of Scientific Research and Innovations, Yaounde, Cameroon

<sup>2</sup>Economist/ Researcher; National Centre for Education,  
Ministry of Scientific Research and Innovations, Yaounde, Cameroon

<sup>3</sup>Integrated Rural Development / Researcher, National Centre for Education,  
Ministry of Scientific Research and Innovation, Yaounde, Cameroon

Article DOI: <https://doi.org/10.36713/epra7496>  
DOI No: 10.36713/epra7496

## ABSTRACT

*Batibo subdivision has several medicinal plants used in the treatment of diseases; among them is king grass, which has been used by traditional healers in the treatment of several diseases some of which have defied modern or orthodox medicines. This research examines the uses of king grass among herbalists or traditional healers in treatment of a wide spectrum of diseases which are believed to be attributed by both physical and spiritual causes. Data for the study was collected through documentation, interviews, observations, and group discussions. Results indicates that king grass has about seventeen uses for treatment of tropical diseases which have defied conventional approaches. However, the greatest handicap encountered by healers is their inability to harvest and preserve the plant in its fresh forms as preferred by the healers. Research for preservation of the plant in its fresh forms can save lives during season of scarcity. It is therefore necessary for government and its agencies to create an enabling environment for preservation of the plant than relying on seasons when it is made available. Research in postharvest for the plant will increase its availability and accessibility to actors as its life saving potentials will no longer be seasonal.*

**KEY WORDS:** Anthropological Approach, Diseases, King grass, medicinal plants.

## INTRODUCTION

African societies have used herbs to promote healing of many diseases in ways and approaches different from orthodox or modern medicines (Bussman, 2006). The availability of modern medicines has not prevented the use of indigenous knowledge systems in the treatment of diseases in most areas, a reason why herbalists practice this occupation even in urban areas where modern medicines are accessible and affordable. The use of

herbs or medicinal plants in the treatment of diseases was identified long before the invention of modern medicines in Europe and America. As the European and American societies developed in science and technology less emphasis was placed in the use of raw herbs in the treatment of diseases (Reinaldo, 2001). On the contrary, herbal and traditional medicine was promoted in societies of Africa and Asia including South America which have not advanced significantly in modern medicines. Ngoe



and Manu (2016) argues that African societies can never abandon traditional approaches to cures because there exist a myriad of diseases that cannot be treated by the use of orthodox medicines in both developed and developing countries. Both researchers further argue that modern medicine was developed from plants through solvent extractions from those plant components that had been identified by herbalists and tradi-practitioners in the treatment of diseases and that modern medicines cannot provide cure for most diseases and illnesses. According to Dewa (2002), every leaf or bark of plants contains two components, the physical component where chemical elements constituting the plant could be identified in the laboratory and metaphysical components that cannot be identified in the laboratory. For example patients suffering from spiritual problems attributed to witchcraft and other supernatural causes can only be treated by a spiritualist using those components that cannot be identified in the laboratory. This may help to explain why most developing societies depend on medicinal plants for treatment of diseases. According to WHO (2009), about 80% of the populations of African countries depend on traditional medicines in the treatment of diseases and an integration of both modern and traditional or herbal cures into healthcare systems could provide a remedy for thousands of people who suffer from diseases that can only be treated by unorthodox means.

Plants provide the basis for the development of modern drugs and to ignore traditional medicine by laying emphasis on orthodox or modern medicines is failure on the part of governments and its agencies. It is for these reasons that the World Health Organisation (WHO) have been actively involved in programmes for the development of traditional or herbal cures since 1977. It is hoped that when the WHO programmes for medicinal plant development are introduced in Cameroon King Grass could be implicated due to its diverse uses in many parts of Cameroon; and Batibo subdivision in particular. King grass handles diverse diseases and also destroy disease symptoms before they could develop into devastating illnesses. According to Okoli et al., (2007), herbal practice on the African continent dates as far back as 4000 years and was the sole medical system of health care before the advent of modern medicine. In African societies the use of herbs like King grass (*Ageratum Conyzoides*) among other is widespread, providing cures for a wide spectrum of diseases. It is for these reasons patients suffering from diseases that defy modern medicines are evacuated to herbal homes where medicinal plants are used for treatment. In Cameroon medicinal plants have been used in the treatment of complications such as liver problems, kidney dysfunctioning, food poisoning, erectile problems including weak sexual

drive, nervous diseases, bareness in men and women, hyernia, headaches, mental disorder, fevers(malaria, yellow fever, typhoid etc) and most diseases attributed to witchcraft and other supernatural causes that cannot be successfully handled by orthodox approaches.

Reinaldo, (2003: 7) writes:

*There are many reasons from blind desperation to the active, positive search for a transformation that explain why people are willing to consult a herbalist or other alternative therapists. One strong motivation force of growing importance is the fear (imagined or real) of drugs and their side effects, as well as the traumatic effects of surgical operations.*

However it has been observed that knowledge of medicinal plants is rapidly declining in some parts of Africa and Cameroon in particular due to deforestation which extincts plant species, changing life style attributed to westernization and urbanisation, reduction in the number of traditional healers due to loss of interest among the younger generations, and increasing use of modern health care facilities.

#### Objectives of the study

1. Identify the various agro-ecological areas where king grass can be found in Cameroon.
2. Identify the various types of diseases treated by the use of the king grass in Batibo Subdivision.
3. Examine the reasons for the decline in the use of medicinal plants in the study area.

#### METHODOLOGY

##### Study area

The study took place in the Moghamo clan in Batibo sub division, Cameroon. Moghamo clan is among the areas in the Northwest region where traditional approaches are highly practiced and respected by the people. The clan has reputable traditional practitioners who are said to have acquired the knowledge by divination and inheritance. Contrary to other places in the Cameroon, where the practice of traditional medicines has seen a decline, in Moghamo the use of traditional medicines has not declined significantly because modernisation and other factors have not affected the life style of the people. In contemporary Moghamo society people pride in the knowledge of traditional medicines is a way of life of the people. This is because most tradi-practitioners in the clan have been handing over the knowledge of traditional medicines to other generations either through divinations or by inheritance.

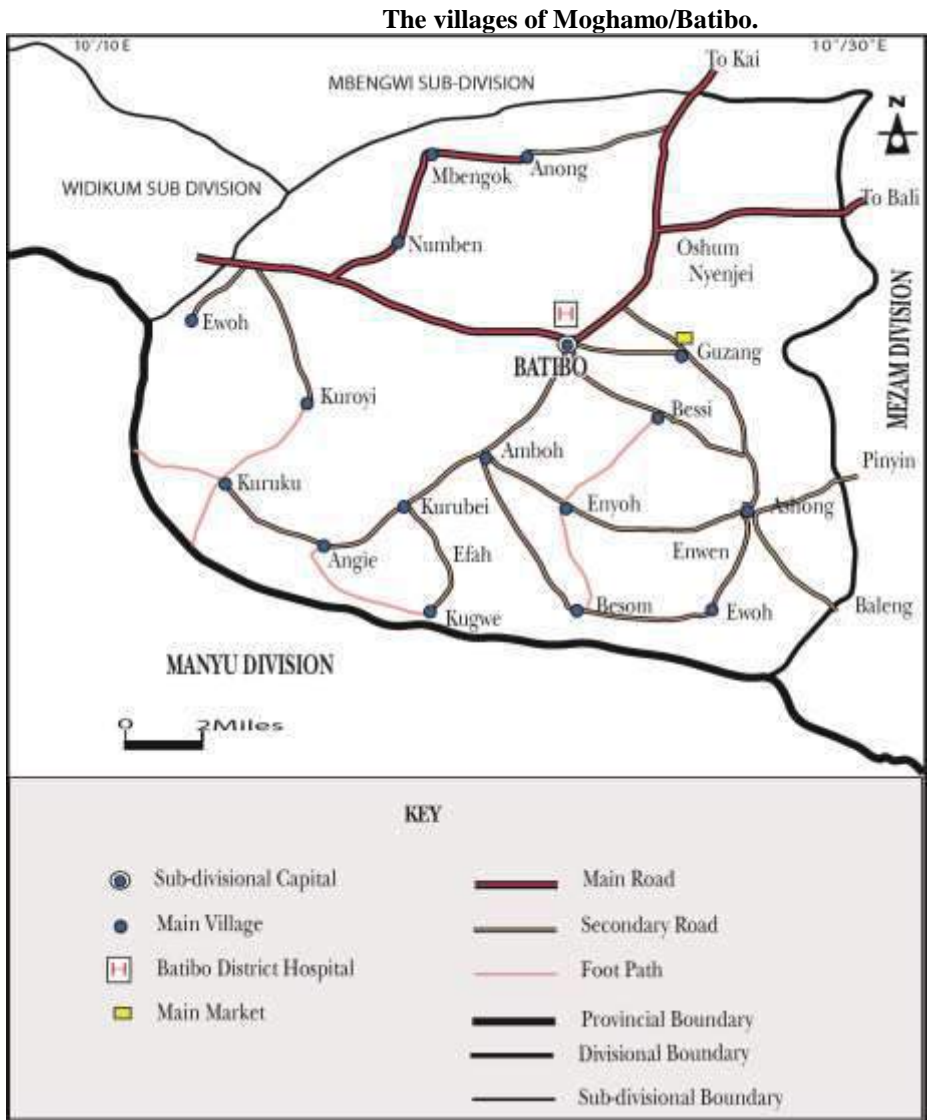




**The Location of Moghamo**

The Moghamo community is located between latitudes 4°95', and 5°45', North of the Equator and longitudes 10°10', and 10°30', East of the Greenwich Meridian Ayah P.A (2001). Moghamo enjoys both the equatorial rain forest agro-ecological zone and savannah vegetation. The equatorial rain forest area is situated in the South along the Mamfe-Bamenda high way between Widikum and Bali towns. Batibo, the head quarters of the Moghamo clan which also

serves as administrative capital of Batibo subdivision, is located 40km along the Bamenda Bali- Batibo Road with a surface area of about 415.9km<sup>2</sup> with a projected population of over 100,000 people, (Cameroon Population estimates, 2009). The Sub division is surrounded in the east by Momo division, south by Widikum subdivision, north west by Mbengwei subdivision and Bali subdivision and in the south west by Fontem subdivision in Libialem division.



Source: Batibo Rural Council, (December, 2010) by Afu I. K. (2012: 39)

**DATA COLLECTION**

**Sampling procedure**

The study was conducted in twenty two villages of the Moghamo clan of Batibo subdivision. The villages were randomly selected in the clan because herbal or traditional practitioners are found in every village of the clan. Traditional healers were selected

by purposive sampling because though every village in the Moghamo tribe practice herbal healing not everybody is involved in the practice.

**Primary data sources**

Primary data was collected by interviews guide, Focus Group Discussions (FGD), and direct



observation of the activities of traditional healers in the treatment of patients by use of king grass. Direct observation also involved an identification of the areas where king grass is commonly found since not yet domesticated. These methods of data collection were used to maximize data credibility, reliability and validity in order to reduce chances of bias by investigators. Focus group discussions were conducted among the actors to understand group experience on medicinal plants and obtain more information on its uses.

### Secondary data sources

Secondary data was gathered by documentation from existing works on medicinal plants and king grass in particular. This was obtained through scientific journals, text books, articles on websites and from institutional libraries such as: Faculty Arts, Letters, Social and Human Sciences of the University of Yaounde, the Botanical and Specialised Research Centre, Institute of Research in Agricultural Development(IRAD), Yaounde; Centre for Applied Social Science-Research and Training(CCAS-RT), the Batibo Rural Council Library(BRCCL), Cercle, Philo-Psyco-Socio-Anthropo(CPPSA), and Ministry of Scientific Research and innovation(MINRESI). Information from these sources was useful in understanding the uses of King grass beyond Batibo subdivision

### Data analysis and interpretation

The qualitative method of the study was used in the interpretation of primary data. These were arranged according to the objectives. Data interpretation was done by the use of two theories, namely the ethno-perspective theory as well as the functionalism theory. The ethno perspective theory of Mbonji Edjenguèlè is characterized by three elements; holisticity, cultural endosemy and contextuality which were used to provide the uses of the king grass. The cultural endosemic focus holds that every society has inner meanings that it attaches to phenomena. The theory was used to get perceptions that people in the Batibo community have concerning the contribution of the king grass to health care system of people. The functionalist theory of Malinowski; specifically, Merton's notion of Hidden function and manifest function of king grass. According to the author's perception of functionalism, all standardized social

and cultural beliefs and practices are functional for both the society as a whole as well as individuals in that society.

## RESULTS AND DISCUSSIONS

### Areas of propagation of king grass.

The study reveals that King grass is found almost everywhere in the rainforest zone of Batibo subdivision, especially in secondary forests and residential areas. It was found as a nuisance growing around buildings, residential homes, farms, garden, behind, some office buildings, streams and springs and moist sheltered places. The plant is commonly found during the wet than dry season as it withers and perishes during prolonged hot weather conditions. Under favorable conditions its leaves are green with soft stems which harden with maturity. During the dry season, the plant losses moisture when it is not sheltered under trees, canopy, or near water sources. It hardly grows where there is bahama grass. King grass bears white light flowers whose components are easily propagated by wind. Its leaves are soft and easy to crush by hands or mortar. King grass is among the few medicinal plants which are hardly consumed by other animals despite its diverse medicinal uses.

King grass is important in the treatment of diseases attributed to physical and supernatural causes. According to Fennel et al; (2004) king grass can equally be dangerous to the health of men and cautions that men weeding or harvesting king grass must always wash their hand before touching their male organs as it causes weak sexual drive as revealed by actors. These findings help to explain why women are more involved in weeding the grass than men as it has zero effect on the private organs of women as they hardly touch their private organs during urination.

### Identification of medicinal uses of king grass

Respondents revealed that king grass is used to treat both supernatural and natural illnesses. It was further revealed that the plant is used in treating about seventeen natural illnesses/diseases in the study areas. The table below indicates the various types of diseases treated by king grass and part of the plant used.



**The Different illnesses/diseases treated by using the king grass**

Illnesses/diseases	Part(s)/components used for treatment	Procedure for preparation /administration to patients
Frontal headache	Leaves	Grind the leaf and apply on the fore head by massaging. The patient is made to shake the head continuously during massaging
Abscess	Leaves	Warm the leaves on flames of fire from wood (not gas) or on top of any hot object and apply on the affected area.
Sore throat	Leaves	The fresh leaves are washed, chewed and swallowed with the greenish juice/ chlorophyll.
Diarrhea	Leaves	Squeeze the leaves, extract the juice and drink.
Heart burn	Heads of the herb	Squeeze 7 heads in half glass of water and drink.
Constipation	Leaves	Harvest 7 leaves and chew.
Cataract (eye problems)	Leaves	Extract the juice from the leaves and put in a funnel made from plantain of banana leaves and apply like eye drops.
Ear problems	Heads of the herb	The sap is extracted and mixed with grinded alligator pepper and applied in the affected ear through a traditional funnel.
Typhoid	The whole plant	The herb is put in decoction in the preparation of a typhoid medicine, used in drinking.
Malaria	Leaves	A decoction of the leaves with other herbs and palm wine are prepared and used to drink.
Abdominal pain	Heads of the herb	Boil four heads of the plant in 4 liters of water and drink, ½ glass four times daily.
Whitlow	Whole plant	People suffering from whitlow should grind both the king grass and alligator pepper and apply on the affected finger for some time.
Loss of Appetite	Whole plant	Grind the leaves and add palm oil to make a paste. Give it to infants half tea spoon full.
Poison	Leaves or heads of the plant	Chew seven leaves of the plant in combination with seven seeds of alligator pepper.
Menstrual pains	Heads of the Plant	Squeeze and drink the juice extracted from the herb.
Rheumatism	Heads of the plant	Warm and mix with grind alligator pepper and massage the affected part.
Skin rashes	Heads of the plant	Boil the herbs and use water to bath the affected victim.

*Source: Mukum Cenotar, (July 2014)*

The above table shows that some diseases treated by stem, flowers and the roots in the treatment of diseases. king grass as well as the parts of the plants identified or Chin *et al*,(2006) puzzles how traditional healers implicated are treating the diseases. In this study it was identified the various parts of plants for treatment of observed that traditional healers have identified specific diseases while Funnel *et al*,(2004) are other opinion that parts of king grass for treatment of some diseases. scientific wisdom alone cannot unveil the mystery of Sometimes the whole plant could be used like the leaves, plant uses since some properties have been obtained



through inheritance or handed down by divination. Respondents also made mention on how the plant is applied on the affected areas of a patient to ascertain the effectiveness of the plant in the treatment of specific diseases. It was revealed that when administering treatment by use of the leaves of king grass emphasis is laid on harvesting seven leaves of the plant. Other studies and practices on use of seven leaves of king grass have different interpretation spiritually and physically depending on the tribe. In Batibo subdivision the traditional healers revealed that the seven leaves used for treatment represent the seven gods of the Batibo land both in the physical and spiritual realms. This revelation implicating the gods is evidence that king grass has physical and spiritual values for treatment of diseases. According to Wimbun C. (1988), the herbalists are of the opinion that the gods do not accept even numbers of leaves in the treatment of diseases as they do not like to share equal status with the physical world since their contributions are greater for the treatment of diseases. Healers believe that when treating with king grass it is the seventh leaf that links the patient to the spiritual world for treatment especially when the sickness has been attributed to supernatural forces. Such diseases require treatment beyond the physical realm.

This is in line with the works of Burkill, (1985) who investigated the usefulness of medicinal plants in aspects of therapy. According to the research the sap from fresh king grass leaves provides cures for chronic sores and for frontal headache. The same study revealed that sap from *ageratum conyzoides* leaves is used as pain killer during pregnancy; especially when there are difficulties to exit the foetus, and also in visual problems. Also, studies by Dewa, (2002) confirms and supports that *ageratum conyzoides* is used to treat hazy vision and eye pains. Respondents briefed on how to administer the herb to treat eye problems by squeezing the juice extract as eye drop. These uses have been confirmed in the field work experience on king grass as indicated on the table above.

In addition, Focho et al., (2009) reported that the leaves of the king grass can be chewed to remedy dysmenorrhoea a situation in women whereby they feel abdominal pains during menstruation. Focho recommends the chewing of fresh king grass leaves for women suffering from painful menstruation as solution to the problem.

Olatunji and Iranloye, (2008) in their findings reported that king grass has gastro- protective properties. Both researchers meant that king grass can be used in the treatment of gastric pains and can also be used as a means to prevent the illness. This is in line with our findings because Batibo people also use the *ageratum conyzoides* plant to treat people suffering from gastritis; when decocted with other medicinal herbs.

Mofor, (2010) explains how herbs are used as preventives and cures by identifying common diseases that affecting man. Equally the ways of using various herbs to combat ailments for illnesses treated by use of king grass such as whitlow, migraine or frontal headache and as well as mystically oriented poison. In this study the herbalists identified two categories of king grass, namely, the male and female species. It was revealed that the female species of king grass is widely used in the treatment of supernatural diseases like night poison attributed to men having spiritual wives or women having spiritual husbands with whom they make love in dreams, spiritual or metaphysical world. When these acts become rampant the victims become sexually impotent or may be involved in sex without conception. The victims of night poisoning becomes unproductive and could visit clinical or modern hospitals in their life time without solution unless they are introduced to a herbalist who knows the solution to the problem. Another form of night poisoning revealed in the study is eating food in the dream world. Victims of this type of night poisoning are commonly identified with common diseases like fevers, headache, stomach disorder, body pains, and even erectile problems which become a common life phenomenon in them with no solution from the physical realm.

Foster and Anderson, (1978) writes that all societies have "*Disease Theory Systems*" to identify, classify and explain illnesses, their causes and remedies. Among the prominent theories supporting the "*Disease Theory Systems*" is the Personalistic Disease theory which attributes or associates diseases to the works of sorcerers, witches, ghosts, or ancestral spirits, and possession. Thus, in the Personalistic Disease theory illnesses are attributed to the work or acts of other people through supernatural beings. In accordance to this theory a victim could be sick as a result of jealousy and envy from other people or when the victims out of ignorance undermines supernatural laws and taboos that govern societies. Such taboos are most often disrespected or undermined by scholars of western orientation who often believe that all illnesses could be handled by orthodox or modern medicines. In this case, the causes and cure of these illnesses cannot be diagnosed and treated in the natural world. By this understanding, sufferers, their families, associations all participate to seek for solution from traditional healers who will use herbs with other objects like wooden bowls, rusted matchets, skulls of animals and in rare cases those of human beings for treatment of diseases. In Batibo, people suspected by their family members to be victims of strange diseases are taken to the herbalist or traditional doctors for treatment.

In this study the work of the herbalist had limitations due to his inability to show researchers





the various ways of preventing diseases though respondents acknowledge that the diseases could be prevented. Generally, the Moghamo people do acknowledge that these diseases could be prevented by using king grass or by “cleansing”; a process

whereby the herbalist uses other herbs to dispel spiritual forces responsible for the illness from the body of the victim. The pictures below shows the male and female species of king grass and also the treatment of ear diseases by use of king grass.

### The Female and male king grass species



*Source: Authors, (October 2017)*

A herbalist using king grass in treating a patient from ear problems



*Source: Mukum Cenotar, (October 2017)*

Mc Elroy and Townsend, (1989) laid emphasis on the fact that health and healing can be understood best in terms of the ethno medicine of a society while the insiders view is important to understand how an ethnic group defines and diagnoses diseases. He further explains:

*Physicians in almost every part of the world have from time to time encountered a very special kind of patient the sorcery victim. This patient may believe that he or she has been attacked by a sorcerer or has broken on absolute taboo. No matter how the Western physician tries to treat the terrified patient, the patient believes*

*that death is inevitable; becomes weaker each day and may actually die.*

In this type of situation, only the tradi-practitioner has the last word concerning the patient’s recovery or death since a medical doctor cannot be able to identify the real cause of the illness affecting the patient. The medical doctor may not be able to diagnose an illness from a patient suffering from a curse or mystical poison or the cause of bareness. According to Fennel et al; (2004) sickness attributed to spiritual causes can never be handled in western or orthodox treatment. According to the research the patient may even manifest the symptoms of ordinary diseases like malaria, headache, fevers and even body pains which could be treated by modern medicines





but will never respond to treatment unless traditional cures are implicated. Most of the respondents explained that illnesses attributed to witchcraft often result during land disputes between friends, neighbours, relatives or brothers especially problems of succession and inheritance, abandoned traditional rites, as well as issues of jealousy. These results are in line with studies by Titus *et al.*, (1979) are of the view that:

*“The crucial sources of problems seem to be the impossibility of achieving fairness by the standards of all heirs and the impossibility of dividing some chattels and real estates equally”*

This type of situation often results to jealousy among the contenders who most often seeks ways to punish others so that they can get much of the property by afflicting them with illnesses. Most often the contesting parties over inheritance may plant mystical poisons on the land for the concerned to die. Pauline (2002) attests that:

*“Conflict over land underlies most of the disputes we face, and is central to the division of families and in effect turns family members into strangers”.*

With situations of this nature, it involves biases among contending parties which provokes anger and the spirit of vengeance while poisoning or killing are common amongst the people. Victims who fall sick as a result of these can only be treated by the traditional doctor using medicinal plants identified for the treatment of the inflicted diseases. Treatment by king grass together and other combination of plants is most often the remedy.

### **Declining use of king grass and other medicinal plants**

This study indicates that in spite the overwhelming uses of king grass as remedy and cure for a wide spectrum of diseases there is growing fear that the practice of traditional cures may decline. Thus, putting future generations at risk in a subdivision where there are limited number of handicapped modern clinics, hospitals and where more than 80% of the population depend on traditional approaches to the treatment of diseases. These reasons are supported by study observation in various herbal homes implicated for the study. It was rather embarrassing that close to sixty percent of the herbal clinics were coordinated by men and women above seventy years of age while those who assisted them were men in their forties as revealed by the respondents. A few herbal homes were run by men who identified themselves among the late thirties and forty age brackets. There were few men and women in their twenties. This means that when the present generation of practitioners die or are made handicap by age the practice of traditional medicines will experience a steep decline that cannot be

compromised. There will be limited number of people to engage in the practice as revealed by field work evidence. The following reasons were advanced by for future decline of traditional treatment by king grass amongst others.

- 1) The growing influence in the use of modern medicines for the treatment of diseases.
- 2) The regard of traditional practices as a hobby and not as profession as it was before colonial period when everybody was compelled to know the usage of plants.
- 3) The growing influence of religion and misconception about the use of herbs like king grass. Many missionaries and contemporary religious organisations are quick to condemn than investigate or understand certain practices like sorcery as paganism to Christian followers.
- 4) The growing influence of western education which does not warrant young people to stay at home and learn traditional practices with respect to medicines.
- 5) Government inability to integrate traditional medicines and modern medicines into the countries health care delivery system. Though the Cameroon government has issued licenses for people to practise traditional medicines, herbalists are often referred to as “charlatans” by their colleague of modern medicines.
- 6) Exploitative tendencies of most traditional practitioners.

Despite these causes of decline advanced by respondents we are still hopeful that the practice cannot be extinct knowing its importance in most rural communities.

### **CONCLUSION**

Most communities fail to acknowledge that diseases can be caused by both natural and supernatural forces. As a result they depend solely on physical cures after diagnosis especially drugs from modern hospitals. They fail to understand that majority of illnesses could be attributed by both physical and spiritual causes. The people in Batibo strongly believe that both physical and spiritual forces are implicated in the causes of sickness in human beings. It is for these reasons that patients who cannot be treated by modern medicine or conventional means are referred to herbalists or traditional healers vested in identifying diseases attributed to supernatural forces like witchcraft, curses and taboos. This is because they believe that the healers have extensive knowledge about the use of herbs. As a result there exist values of trust, respect and confidentiality between the healers and



the people of Batibo who are affected by these supernatural diseases. One of the greatest problems encountered with the use of king grass for herbal cures is that despite its importance in the treatment of diseases, there are growing fears that the knowledge about the plant could be extinct by generations of people. Thus, these people are not interested in promoting the uses of the plant despite its contribution as health remedy and cures in Cameroon and Batibo sub division in particular. It is widely known that spiritual values of medicinal plants are destroyed once the plants undergo industrial treatment in pharmaceutical industries.

It is for these reasons that one of the objectives of this study was to identify the uses of the plant so that researchers and herbalists may be vested with the wide spectrum of diseases the plant cures. Also there is need for scientists and medical researchers to integrate this plant species into mainstream research especially in areas like easing pains of delivery during child birth and reducing painful menstruation and other health problems. In addition there is need to sensitize youngsters on the knowledge of king grass especially as more than 80% of the population of the area depend on traditional remedies in the treatment of ailments. It is hoped that this research will serve as source of information and data base for policy-makers, scientists, and farming communities to develop strategies for the development of the medicinal plant sector.

## REFERENCES

1. Ayah, P.A, (2001). *Elements for a History of the Moghamo Clan from Early Settlement-1916 Cameroon, Dissertation for Masters. FALSH, University of Yaounde I.*
2. Bi Holong.M., (1986) *Contribution à l'étude de la Flore du Cameroun les Asteraceae. Thesis in Plant Biology. FASC, Université de Yaoundé I.*
3. Burkill, H.M., (1985). *The Useful Plants of West Tropical Africa. 2<sup>nd</sup> Edition, Royal Botanic Gardens, Kew. University Press of Virginia.*
4. Bussman R. and Douglas S., (2006). *Traditional Medicinal Plant Use in Northern Peru: Tracking Two Thousand Years of Healing Culture. J Ethnobiology Ethnomedicine vol.2, pg46.*
5. Butler M.S., (2005). *Natural Products and Drugs: Natural Products Derived Compounds in Clinical trials. Natural products Rep 22:162-195.*
6. Chin Y.W., Balunas M.J., H.B chai and A.D Kinghorn (2006). *Drug Discovery from Natural Sources. Geneva.*
7. Cunningham A.B., (1988). *An Investigation of the Herbal Medicine Trade in Natal/Kwazulu Natal. Investigation Report No 29 Institute of Natural Resources, University of Natal, Pietermaritzburg.*
8. Focho D.A., EAP Nkeng, Lucha C.F., Ndam W.J., and Afegenui A., (2009). *Ethnobotanical Survey of Plants used to Treat Diseases of the Reproductive System and Preliminary Phytochemical Screening of Some Species of*

- Malvaceae on Ndop. Journal of Medicinal Plants Research,3 (4), 301-314.*
9. Foster G.M. and Anderson B.G., (1978). *Medical Anthropology, New york*
10. Funnel C.W., K.L. Lindsey., McGnaw L.J., Spang S.G., Statford G.I., Egorash E.E., Grace O.M., Van J., (2004). *Assessing African Medicinal Plants for Efficacy and Safety: Pharmacological Screening and Toxicology. Journal of Ethnopharmacology, Elseiver.*
11. Mbonji (2009). *Santé, Maladies et Médecine Africaine. Plaidoyer pour l'Autre Tradi-Practique, Yaoundé, PUY.*
12. Mbonji.E.(2005). *L'Ethnoperspective ou La Méthode du Discours de L'Ethno-Anthropologie Culturelle, Yaoundé PUY.*
13. Mc Elroy and Townsend P.K., (1985) *Medical Anthropology in Ecological Perspective, Second Edition, Boulder Colorado U.S.A.*
14. Mofor P. (2012). *Natural Herbal and Preventive Medicine: A 21<sup>st</sup> Century Health Guide for Every Home. Cameroon.*
15. Ngoe Fritz Eseokwea and Manu Ibrahim(2017) : *HIV/AIDS and Commercial Agricultural Sector in Cameroon : Impact, Vulnerability and Strategies to Reduce Prevalence Rates. International Review of Human and Social Sciences, Vol. 7, Number 7, February 2017.*
16. Nkuinkeu.R. (1998). *Plantes Médicinales et Exploitation Forestière. Les Produits Forestiers Non Ligneux en Afrique Centrale. Recherches Actuelles et Perspectives pour la Conservation et le Développement. FAO: Rome.*
17. Nkwi. P.N., Nyamongo I.K. Gery, Wayne and Ryan, (2001). *Field Research in to Socio Cultural Issues. Methodological Guidelines, Yaounde, Cameroon.*
18. Odugbemi T. (2006). *Outlines and Pictures of Medicinal Plants from Nigeria. University of Lagos Press.*
19. Okoli C.O., Iwueke A.V., and Nwodo O.F.A., (2006). *Evaluation of the Anti-Inflammatory and Analgesic Activities of Vitex Doniana Leaves. Afr J Biotech, 5(20):1929-1935.*
20. Olatunji B. and Iranloye B.O., (2008). *A Textbook of Medicinal Plants from Nigeria: Antiviral Properties of African Medicinal Plants. University of Lagos.*
21. Pauline E.P, (2002) *Bewitching Land: The Role of Land Disputes in Converting Kin to Strangers and in Class Formation in Malawi. Journal of Southern African States, Vol.28 pg 155-178.*
22. Reinaldo G.S., (2003). *Amazing Power of Healing Plants. Inter-American Division Publishing Association. Florida.*
23. Titus, Sandra.L., Paul. C., Rosenblatt and Roxanne.M. Anderson. (2002). *Family Conflict Over Inheritance of Property. JSTOR, Vol.28, No.3, pp.337-346.*
24. Wimbun C., (1988). *The Curative Plants of the Herb Doctor: Pharmacy, Macomb - 1993. Types of Medicinal Plants. Vol.3 relieves Bamenda.*
25. World Health Organisation (1978). *Traditional Medicine and Health Care Coverage: A Reader*



*for Health Administrators and Practitioners.  
Geneva.*

- 26. *World Health Organisation (2002). Monographs on Selected Medicinal Plants, Vol. 2, World Health Organization, Geneva.*
- 27. *World Health Organisation (2003). Traditional Medicine. Fact sheet Number, 134, Geneva.*
- 28. *World Health Organisation (2003-2005). Traditional Medicine Strategies, Geneva.*