

Chief Editor

Dr. A. Singaraj, M.A., M.Phil., Ph.D.

Editor

Mrs.M.Josephin Immaculate Ruba

EDITORIAL ADVISORS

1. Prof. Dr.Said I.Shalaby, MD,Ph.D.
Professor & Vice President
Tropical Medicine,
Hepatology & Gastroenterology, NRC,
Academy of Scientific Research and Technology,
Cairo, Egypt.
2. Dr. Mussie T. Tessema,
Associate Professor,
Department of Business Administration,
Winona State University, MN,
United States of America,
3. Dr. Mengsteab Tesfayohannes,
Associate Professor,
Department of Management,
Sigmund Weis School of Business,
Susquehanna University,
Selinsgrove, PENN,
United States of America,
4. Dr. Ahmed Sebihi
Associate Professor
Islamic Culture and Social Sciences (ICSS),
Department of General Education (DGE),
Gulf Medical University (GMU),
UAE.
5. Dr. Anne Maduka,
Assistant Professor,
Department of Economics,
Anambra State University,
Igbariam Campus,
Nigeria.
6. Dr. D.K. Awasthi, M.Sc., Ph.D.
Associate Professor
Department of Chemistry,
Sri J.N.P.G. College,
Charbagh, Lucknow,
Uttar Pradesh. India
7. Dr. Tirtharaj Bhoi, M.A, Ph.D,
Assistant Professor,
School of Social Science,
University of Jammu,
Jammu, Jammu & Kashmir, India.
8. Dr. Pradeep Kumar Choudhury,
Assistant Professor,
Institute for Studies in Industrial Development,
An ICSSR Research Institute,
New Delhi- 110070, India.
9. Dr. Gyanendra Awasthi, M.Sc., Ph.D., NET
Associate Professor & HOD
Department of Biochemistry,
Dolphin (PG) Institute of Biomedical & Natural
Sciences,
Dehradun, Uttarakhand, India.
10. Dr. C. Satapathy,
Director,
Amity Humanity Foundation,
Amity Business School, Bhubaneswar,
Orissa, India.



ISSN (Online): 2455-7838

SJIF Impact Factor (2017): 5.705

EPRA International Journal of

Research & Development (IJRD)

Monthly Peer Reviewed & Indexed
International Online Journal

Volume: 3, Issue:11,November 2018



Published By :
EPRA Journals

CC License





SIMULATION OF HYBRID ACTIVE POWER FILTER WITH VARIABLE CONDUCTANCE TO REDUCE HARMONICS IN INDUSTRIAL POWER SYSTEMS USING FUZZY LOGIC CONTROLLER

H. Vijay Krishna

MTECH(EPE), Sreenidhi Institute of Science & Technology, Hyderabad

Dr. K. Sumanth

Professor, EEE Dept, Sreenidhi Institute of Science & Technology, Hyderabad

T. Praveen Kumar

Associate Professor, EEE Dept, Sreenidhi Institute of Science & Technology, Hyderabad

ABSTRACT

In this paper the designing of hybrid active power filter for suppression of harmonic resonance with variable conductance in industrial power systems was explained by using fuzzy logic controller. Harmonic voltage amplification, due to unintentional series or parallel resonance of power factor correction capacitors, is a significant issue in the industrial power systems. Here we are using fuzzy logic controller instead of using other controllers. This paper proposes a hybrid active power filter to suppress the harmonic resonance in industrial facilities. The hybrid active filter, which is composed of a capacitor and an active filter in series connection, operates as variable harmonic conductance with dynamically tuning characteristic according to the voltage total harmonic distortion, so the damping performance of the active filter can be adjusted in response to load change and power system variation. Therefore, the harmonic resonance would be avoided as well as harmonic voltage distortion can be maintained at an allowable level. Compared with the pure shunt active filter, the dc bus voltage of the proposed hybrid filter is dramatically reduced since the grid voltage is supported by the series capacitor. This feature provides a vital advantage of the active filter, in terms of both the kVA rating and the switching ripples. Operation principles are explained in detail, and computer simulations validate the effectiveness of the proposed approach. The simulation was carried out by using MATLAB / Simulink software.

INDEX TERMS: *Harmonic resonance, hybrid active power filter, industrial power systems, fuzzy logic controller.*

I. INTRODUCTION

Compared with active front-end converters, diode or thyristor rectifiers still dominate in high power applications, such as adjustable speed drives, uninterruptible power supply systems, etc. These equipment always injects a large amount of harmonic

current into the power system, which may cause excessive harmonic voltage distortion and even give rise to malfunction of sensitive equipment in the vicinity of the harmonic source. Multiple tuned passive filters are usually installed at the secondary side of the distribution transformer in the industrial

facilities to draw dominant harmonic current and provide power factor correction for inductive loads as well [1], [2].

However, unintentional series and /or parallel resonance, due to the passive filters and nonlinear loads and / or the utility, may result in excessive harmonic voltage amplification [3], [4]. Extra engineering work, therefore, is required to calibrate and maintain required filtering performances. Conventional active power filters intended for compensating the harmonic current of nonlinear loads cannot address the harmonic resonance issues resulting from the passive filters or the power factor correction capacitor [5].

This paper proposes a hybrid active power filter to suppress the harmonic resonance in industrial facilities as well as mitigate harmonic current flowing into the utility. The proposed hybrid active power filter is composed of an active filter and a power factor correction capacitor in series connection. The active filter operates as variable damping conductance at harmonic frequencies. The harmonic conductance is determined according to the voltage total harmonic distortion (THD) at the installation location of the hybrid active filter. Based on this control, the damping performance of the active filter can be dynamically adjusted to maintain harmonic voltage distortion at an allowable level in response to load change and power system variation, where the allowable voltage THD can be regulated according to the harmonic voltage limit in IEEE std. 519-1992 [10]. Since the series capacitor is responsible for sustaining the fundamental component of the grid voltage, the active filter can be operated with a very low dc bus voltage, compared with the pure shunt active filter [11]. This feature is a significant advantage, in terms of both the rated kVA capacity and the switching ripples of the active filter.

Several Hybrid Active Power Filters (HAPF) topologies [2-11, 15-17] constitute active and passive parts in series and / or parallel have been proposed for reactive power and harmonic current filtering in [3-11]. The most common topologies are Shunt Hybrid Active Power Filters (SHAPF) [3-10] consisting of an APF and passive filter connected in series with each other and series HAPF [11] which is a combined system of shunt passive filter and series APF. An extensive overview of the topological structures is explained in [2]. The controller design is a significant and challenging task due to its impact on the performance and stability of overall system. For this reason, numerous control methods such as ‘pq’

theory [3-5], fast Fourier transforms [5], ‘dq’ theory [6-7], fuzzy logic controller [8-9], proportional resonant current controller [10] are control methods applied in the literature.

The growing amount of electric energy generated from distributed or decentralized energy resources (DER), mainly of renewable, requires their appropriate grid integration. Thus, the renewable energy source interfacing with grid is the major issue in the electric utility side. Different types of converter topology in grid interconnection have been improved by researchers to improve power quality and efficiency of the electrical systems [12-13]. This paper focuses the shunt hybrid active power filter interfaces for the renewable energy source with proposed controller. On account of the limitations in the existing literature, the purpose of this paper is the following:

- a) To provide interconnection between renewable source and grid by using shunt hybrid active power filter (SHAPF) with unidirectional isolated DC-DC converter at dc link.
- b) To introduce a new control strategy for reactive power compensation and harmonics elimination.
- c) To adaptively controlled dc link voltage as reactive current component.
- d) To achieve reactive power compensation, i.e., nearly equal to 99% of load reactive power capacity.

This paper primarily focuses on the aforesaid four aspects of the shunt hybrid active power filter.

II. OPERATION PRINCIPLE AND CONTROLLER

A simplified one-line diagram of the proposed hybrid active filter and the associated control are shown in Fig. 1(a). The hybrid active filter unit (HAFU) is composed of an active filtering part and a power factor correction capacitor in series connection at the secondary side of the distribution transformer in industrial facilities.

The harmonic current control, reactive current control and dc link control are achieved by indirect current control. With this control method, any extra start up pre-charging control process is not necessary for dc link. In addition, reactive power compensation is achieved successfully with perceptible amount. Besides, the harmonic compensation performance is satisfactory.

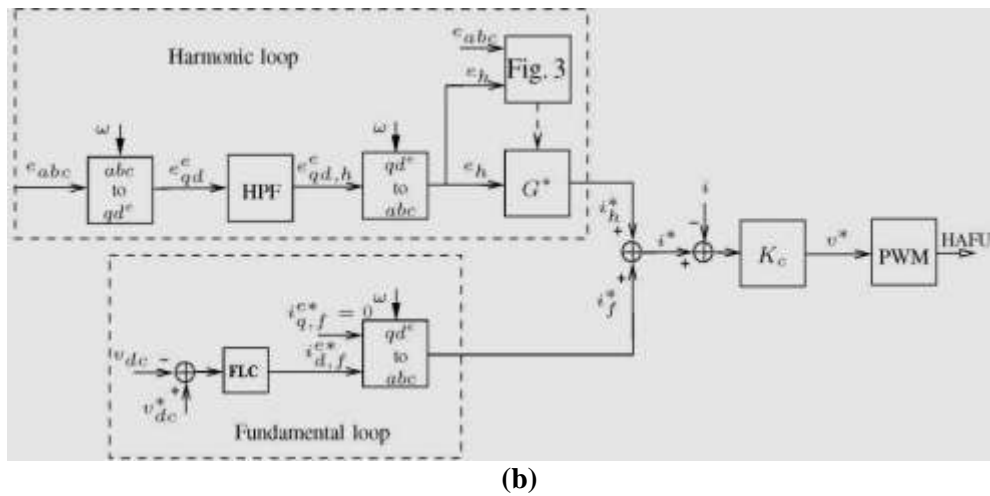
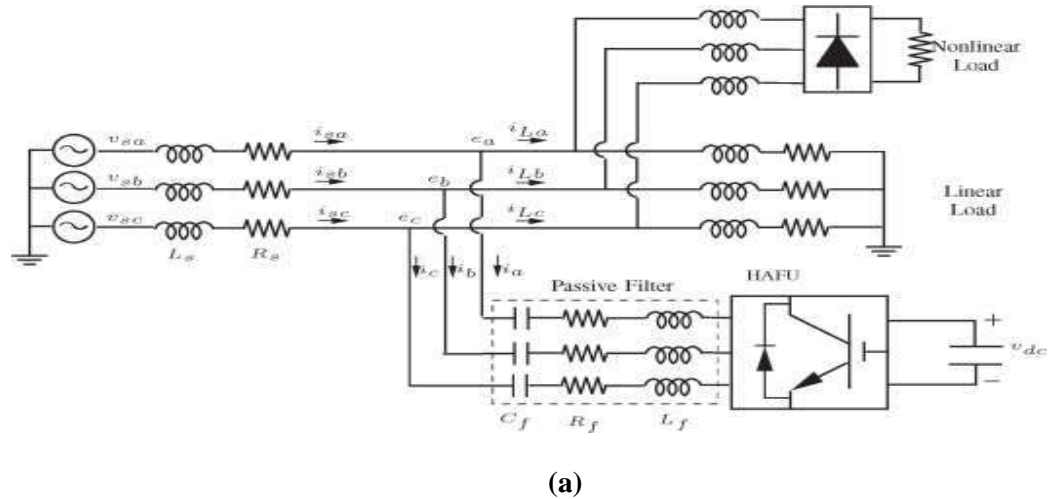

Fig. 1:Proposed HAFU in the industrial power system and its associated control. (a) Circuit diagram of the HAFU (b) Control block diagram of the HAFU

A. Harmonic Loop:

To suppress harmonic resonances, the HAFU is proposed to operate as variable conductance at harmonic frequencies as follows

$$i^* = G^* \cdot e_h \tag{1}$$

Harmonic voltage component ‘e_h’ is obtained by using the so-called SRF transformation [9], where a phase-locked loop (PLL) is realized to determine the fundamental frequency of the power system [28]. In the SRF, the fundamental component becomes a dc value, and other harmonic components are still ac values.

B. Fundamental Loop:

The first step is to isolate the harmonic components from the fundamental component of the grid currents. This is achieved through ‘dq’ transformation (1), synchronized with the

PCC voltage vector, and a first order low pass filter with cut off frequency of 10 Hz. Then the ‘dq’ inverse transformation (2) produces the harmonic reference currents in ‘abc’ reference frame.

Therefore, the control of dc bus voltage is accomplished by exchanging real power with the grid. Thus, the current command is obtained by a fuzzy logic controller. The fundamental current command in the three phase system is generated after applying the inverse SRF transformation. Therefore, the control of dc bus voltage is able to be accomplished by exchanging real power with the grid. Thus, the current command is obtained by a fuzzy logic controller. The fundamental current command in the three phase system is generated after applying the inverse SRF transformation.

$$v_{dc} > 2\sqrt{2} \sum_h \left| \frac{1}{j\omega_h C_f} + j\omega_h L_f \right| \cdot I_h \quad (2)$$

C. Current Regulator:

The current command i^* consists of i^*h and i^*f . Based on the current command i^* and the measured current i , the voltage command v^* can

be derived by using a proportional controller as follows:

$$v^* = K_c \cdot (i^* - i) \quad (3)$$

Where K_c is a proportional gain. According to the voltage command v^* , space-vector pulse

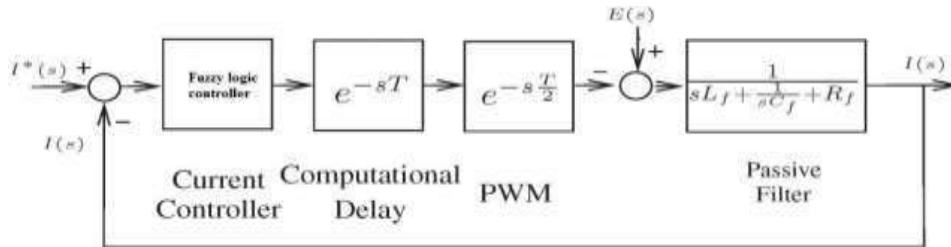

Fig. 2: Closed-loop model of the current control

width modulation (PWM) is employed to synthesize the required output voltage of the inverter. Fig.2 shows the model of the current control. The computational delay of digital signal processing is equal to one sampling delay T , and PWM delay approximates to half sampling delay $T/2$.

D. Conductance Control:

Fig. 3 shows the proposed conductance control. The harmonic conductance command G^* is determined according to the voltage THD at

the HAFU installation point. The voltage THD is approximately calculated by the control shown in Fig. 3. Here, two low-pass filters (LPFs) with cutoff frequency $=20\text{Hz}$ are realized to filter out ripple components [29], [30]. The error between the allowable THD* and the measured THD is then fed into a fuzzy logic controller to obtain the harmonic conductance command G^* . The allowable distortion could be referred to the harmonic limit in IEEE std. 519-1992 [31].

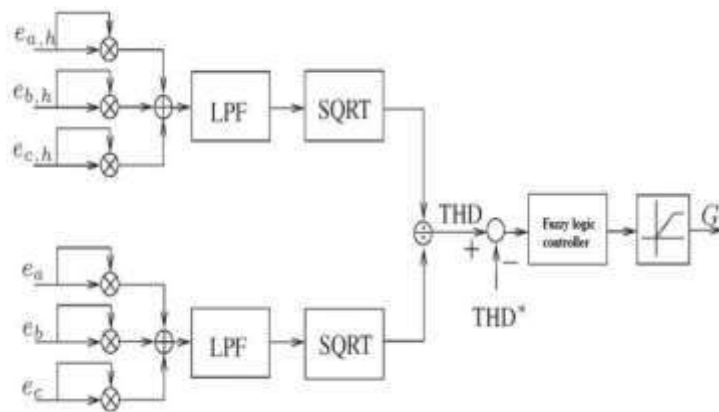

Fig. 3: Conductance Control Block Diagram

According to IEEE std. 519-1992 [31], voltage THD is limited to 5% and individual distortion should be below 4%. Thus, THD* is set in the range of 3% and 5%. If $v_{s,h}$ and R_s are neglected, voltage THD at E , due to harmonic current load I_h , can be expressed as follows:

$$THD = X_{pu} \sqrt{\sum_h (h \cdot I_{h\ pu})^2} \quad (4)$$

The final reference current consists of three phase harmonic reference current signals, three phase reactive reference current signals and dc link control signals.

III. FUZZY LOGIC CONTROLLER

In Fuzzy Logic Controller, basic control action is determined by a set of linguistic rules. These rules are determined by the system. Since the numerical variables are converted into linguistic variables, mathematical modeling of the system is not required in Fuzzy Controller. The Fuzzy Logic Controller comprises of three parts: fuzzification, interference engine and defuzzification. The Fuzzy Controller is characterized as a) seven fuzzy sets for each input and output, b) Triangular membership functions for simplicity, c) Fuzzification using continuous universe of discourse, d) Implication using Mamdani's, 'min' operator and e) Defuzzification using the height method

Fuzzification --Membership function values are assigned to the linguistic variables, using seven fuzzy subsets: NB (Negative Big), NM (Negative Medium), NS (Negative Small), ZE (Zero), PS (Positive Small), PM (Positive Medium) and PB (Positive Big). The partition of fuzzy subsets and the shape of membership CE(k) E(k) function adapt the shape of the appropriate system. The value of input error and change in error are normalized by an input scaling factor. In this system the input scaling factor has been designed such that input values are between -1 and +1. The triangular shape of the membership function of this arrangement presumes that for any particular E(k) input there is only one dominant fuzzy subset. The input error for the Fuzzy Logic Controller is given as,

$$E(k) = \frac{P_{ph(k)} - P_{ph(k-1)}}{V_{ph(k)} - V_{ph(k-1)}} \quad (9)$$

$$CE(k) = E(k) - E(k - 1) \quad (10)$$

Inference Method:

Several composition methods such as 'Max-Min' and 'Max-Dot' have been proposed in the literature. In this paper 'Min' method is used. The output membership function of each rule is given by

the minimum operator and maximum operator. Table-I shows rule base of the Fuzzy Logic Controller.

Defuzzification:As a plant usually requires a non-fuzzy value of control, a defuzzification stage is needed. To compute the output of the Fuzzy Logic Controller, 'height' method is used and the Fuzzy Logic Controller output modifies the control output. Further, the output of FLC controls the switch in the inverter. In UPQC, the active power, reactive power, terminal voltage of the line and capacitor voltage are required to be maintained. In order to control these parameters, they are sensed and compared with the reference values. To achieve this, the membership functions of Fuzzy Controller are: error, change in error and output. The set of Fuzzy Controller rules are derived from

$$u = [\alpha E + (1 - \alpha) * C] \quad (5)$$

Where 'α' is self-adjustable factor which can regulate the whole operation. 'E' is the error of the system, 'C' is the change in error and 'u' is the control variable. A large value of error 'E' indicates that given system is not in the balanced state. If the system is unbalanced, the controller should enlarge its control variables to balance the system as early as possible. Set of Fuzzy Controller rules is made using Fig. (9) and is given in Table-III.

IV. SIMULATION RESULTS

Simulation studies are carried out using MATLAB / Simulink. The main purpose of the simulation is to evaluate the effectiveness and correctness of the control strategy used in the SHAPF with variations of linear loads. Parameters used in simulations are given in Table-I. In simulation, the nominal frequency of the power grid is 50 Hz and the harmonic current source is generated by the three phase diode rectifier.

A power stage setup was built and tested as shown in Fig. 8. Table-I gives experimental parameters based on the per unit system in Table-II.

TABLE I: SIMULATION PARAMETERS

Power system	220 V(L-L), 60 Hz, VD ₅ =0.7%, VD ₇ =0.5%
Transformer	220/127 V, 10 kVA, impedance 5%
Resistive load	2kW(20%)
Nonlinear load	NL ₁ =1.8kW(18%), NL ₂ =2.8kW(28%)
Passive filter	$L_f = 1.0 \text{ mH}(7.8\%)$, $C_f = 150 \mu\text{F}(27\%)$ $Q_f = 20$
Switching frequency	10 kHz
Sampling frequency	20 kHz
Current control	$k_c = 5 \text{ V/A}$
DC voltage control	$k_p = 1 \text{ A/V}$, $k_i = 100 \text{ A/(V} \cdot \text{s)}$, $v_{dc}^* = 50\text{V}$
Tuning control	$k_p = 1 \text{ A/V}$, $k_i = 500 \text{ A/(V} \cdot \text{s)}$, THD* = 2.0% $f_{HP} = 10 \text{ Hz}$, $f_{LP} = 20 \text{ Hz}$

TABLE II: BASE VALUE

Voltage	220 V
kVA	10 kVA
Impedance	4.84 Ω
Conductance	0.207 Ω ⁻¹

Comparison between PI and FLC

PARAMETERS E,I	HAFU OFF%	PI %	FUZZY %
E _s	2.9	2.0	1.47
I _s	8.5	4.8	3.25
I _L	10	9.1	7.43
I _F	27	12	10.23
E _s	4.6	2.0	1.32
I _s	17	4.3	2.9
I _L	13	14	7.42
I _F	43	21	10.99

Fig.8. Fuzzy logic controller

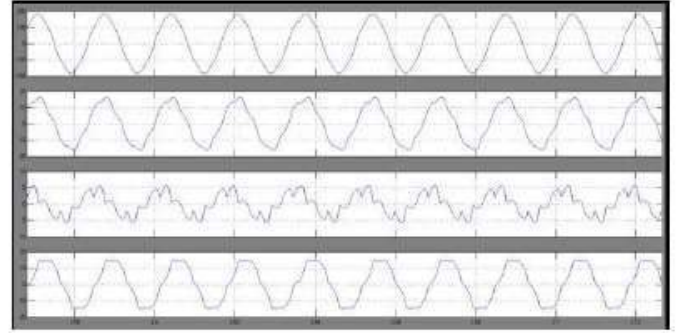
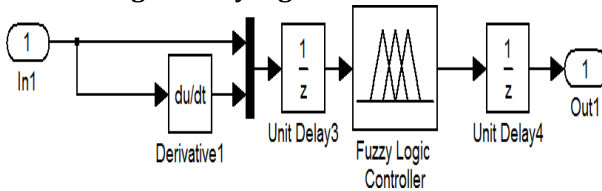
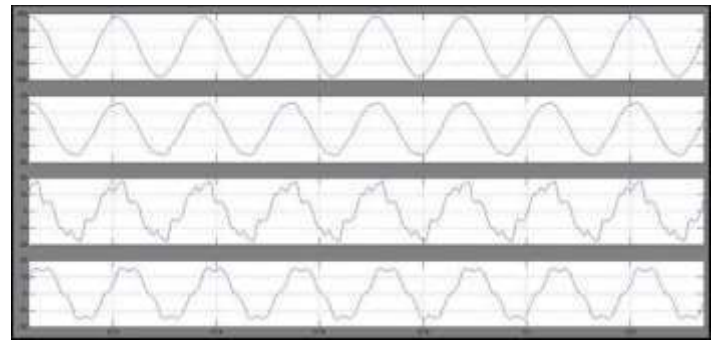

Fig.6: Matlab mo del for proposed system

Fig.7: Matlab model for Control Diagram (a)



(b)

Fig. 9: Line voltage e, source current is, load current iL, and filter current i in the case of NL1initiated. X-axis: 5 ms/div. (a) HAFU is off. (b) HAFU is on

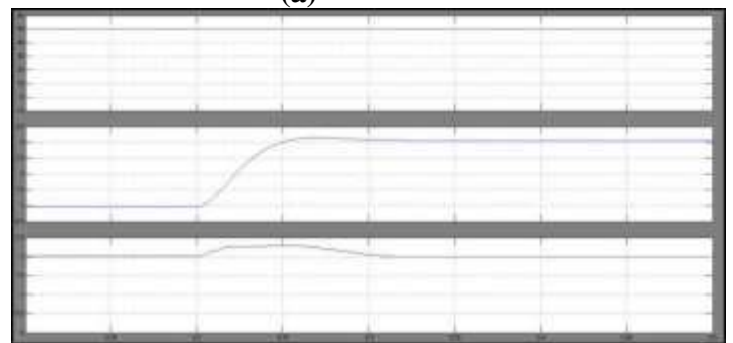

(a)

Fig. 11: Line voltage e , source current i_s , load current i_L , and filter current I in the case of NL2 initiated. X-axis: 5 ms/div. (a) HAFU is off. (b) HAFU is on.

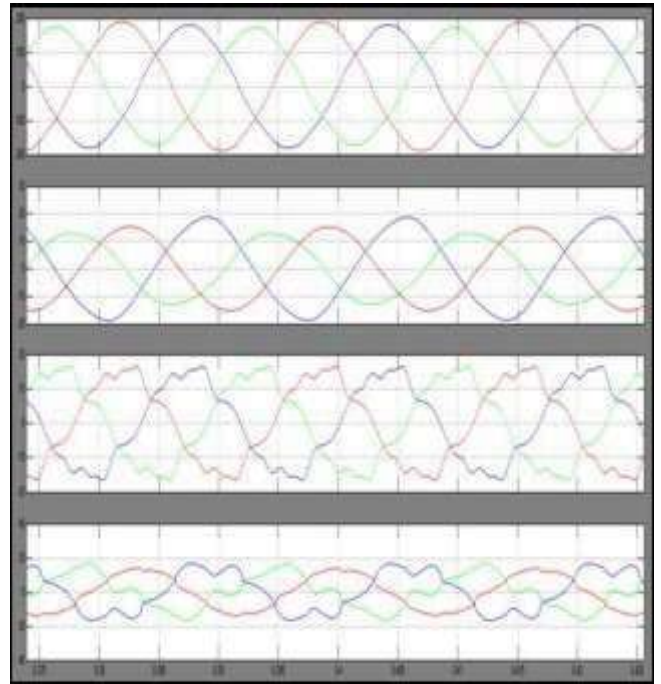
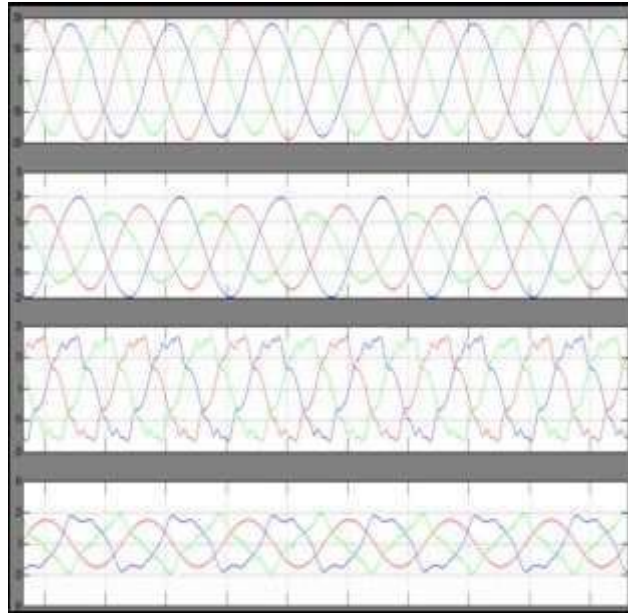
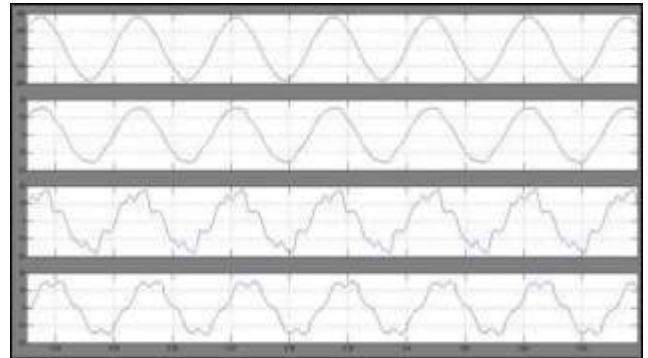
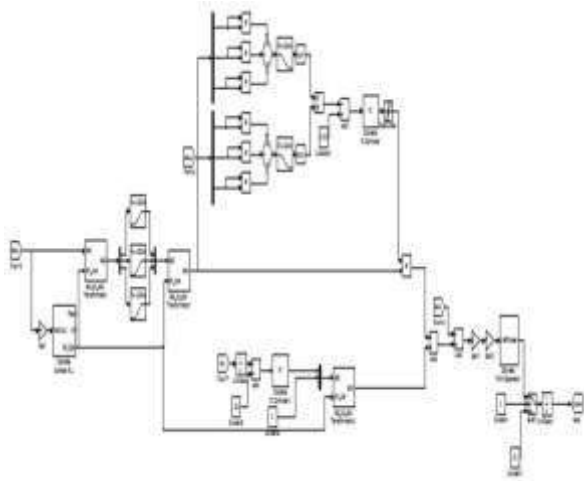
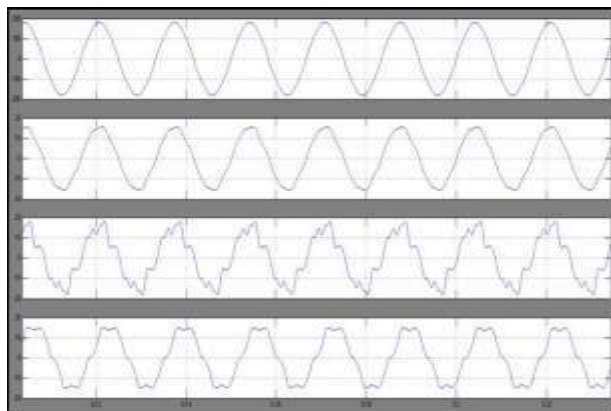

Fig. 14: HAFU is on for single-phase nonlinear load. (a) Terminal voltage. (b) Source current. (c) Filter current. (d) Load Current



V.CONCLUSION

This paper presents a hybrid active filter to suppress the harmonic resonance in industrial facilities with the usage of fuzzy logic controller. The proposed hybrid filter, which is composed of an active filter and a power factor correction capacitor in series connection at the secondary side of the distribution transformer, operates as variable harmonic conductance with dynamically tuning feature in response to load change and the parameter variation of the power system. Therefore, the harmonic resonance would be avoided and harmonic voltage distortion can be reduced and maintained at an allowable level. Since the series capacitor sustains the fundamental component of the grid voltage, the active filter can be operated with a reduced kVA capacity, compared with its counterpart of the pure shunt active filter, which is the significant advantage of the proposed method. Besides, the harmonic compensation performance is satisfactory. In a conclusion, the SHAPF injects RES active power into grid and also enhanced the quality of power at PCC. Simulation results of the three-phase three-wire SHAPF in dynamic reactive power compensation.

REFERENCES

1. R. H. Simpson, "Misapplication of power capacitors in distribution systems with nonlinear loads-three case histories," *IEEE Trans. Ind. Appl.*, vol. 41, no. 1, pp. 134-143, Jan./Feb. 2005. [2] T. Dionise and V. Lorch, "Voltage distortion on an electrical distribution system," *IEEE Ind. Appl. Mag.*, vol. 16, no. 2, pp. 48-55, Mar./Apr. 2010. [3] E. J. Currence, J. E. Plizga, and H. N. Nelson, "Harmonic resonance at a medium-sized industrial plant," *IEEE Trans. Ind. Appl.*, vol. 31, no. 4, pp. 682-690, Jul/Aug. 1995.
2. C.-J. Wu et al., "Investigation and mitigation of harmonic amplification problems caused by singletuned filters," *IEEE Trans. Power Del.*, vol. 13, no. 3, pp. 800-806, Jul. 1998.
3. B. Singh, K. Al-Haddad, and A. Chandra, "A review of active filters for power quality improvement," *IEEE Trans. Ind. Electron.*, vol. 46, no. 5, pp. 960-971, Oct. 1999.
4. H. Akagi, "Active harmonic filters," *Proc. IEEE*, vol. 93, no. 12, pp. 2128-2141, Dec. 2005.
5. A. Bhattacharya, C. Chakraborty, and S. Bhattacharya, "Shunt compensation," *IEEE Ind. Electron. Mag.*, vol. 3, no. 3, pp. 38-49, Sep. 2009.
6. F. Z. Peng, "Application issues of active power filters," *IEEE Ind. Appl. Mag.*, vol. 4, no. 5, pp. 21-30, Sep./Oct. 2001. [9] S. Bhattacharya and D. Divan, "Design and implementation of a hybrid series active filter system," in *Proc. 26th IEEE PESC*, 1995, pp. 189-195