

Chief Editor

Dr. A. Singaraj, M.A., M.Phil., Ph.D.

Editor

Mrs.M.Josephin Immaculate Ruba

EDITORIAL ADVISORS

1. Prof. Dr.Said I.Shalaby, MD,Ph.D.
Professor & Vice President
Tropical Medicine,
Hepatology & Gastroenterology, NRC,
Academy of Scientific Research and Technology,
Cairo, Egypt.
2. Dr. Mussie T. Tessema,
Associate Professor,
Department of Business Administration,
Winona State University, MN,
United States of America,
3. Dr. Mengsteab Tesfayohannes,
Associate Professor,
Department of Management,
Sigmund Weis School of Business,
Susquehanna University,
Selinsgrove, PENN,
United States of America,
4. Dr. Ahmed Sebihi
Associate Professor
Islamic Culture and Social Sciences (ICSS),
Department of General Education (DGE),
Gulf Medical University (GMU),
UAE.
5. Dr. Anne Maduka,
Assistant Professor,
Department of Economics,
Anambra State University,
Igbariam Campus,
Nigeria.
6. Dr. D.K. Awasthi, M.Sc., Ph.D.
Associate Professor
Department of Chemistry,
Sri J.N.P.G. College,
Charbagh, Lucknow,
Uttar Pradesh. India
7. Dr. Tirtharaj Bhoi, M.A, Ph.D,
Assistant Professor,
School of Social Science,
University of Jammu,
Jammu, Jammu & Kashmir, India.
8. Dr. Pradeep Kumar Choudhury,
Assistant Professor,
Institute for Studies in Industrial Development,
An ICSSR Research Institute,
New Delhi- 110070, India.
9. Dr. Gyanendra Awasthi, M.Sc., Ph.D., NET
Associate Professor & HOD
Department of Biochemistry,
Dolphin (PG) Institute of Biomedical & Natural
Sciences,
Dehradun, Uttarakhand, India.
10. Dr. C. Satapathy,
Director,
Amity Humanity Foundation,
Amity Business School, Bhubaneswar,
Orissa, India.



ISSN (Online): 2455-7838

SJIF Impact Factor (2015): 3.476

EPRA International Journal of

Research & Development (IJRD)

Volume:1, Issue:5, July 2016



Published By :
EPRA Journals

CC License





SJIF Impact Factor: 3.476

ISSN: 2455-7838(Online)

EPRA International Journal of Research and Development (IJRD)

Volume: 1 | Issue: 5 | July | 2016

MULTILEVEL INVERTER BASED HYBRID POWER SYSTEM USING PV SOLAR CELL AND WIND SYSTEM

Swati U Gajbhiye¹

¹PG student, Dept. of Integrated Power System, TGPCET, Nagpur, Maharashtra, India

Dr. Hari Kumar Naidu²

²Dean, Dept. of Integrated Power System, TGPCET, Nagpur, Maharashtra, India

ABSTRACT

This paper presents a modelling and control of grid connected Hybrid wind photovoltaic array. Hybrid energy system consists of two or more renewable/non-renewable energy sources. In this paper the hybrid energy system is formed by the combination of wind and photovoltaic array. The modelling of the components of the global system is developed with the integration of converters losses involved in the solar and wind generating subsystem. It is shown that this model is interesting for analyzing the dynamic behaviour of the system and for designing the control strategy.

KEYWORDS: *Wind energy, Photovoltaic, Grid-connected, Hybrid renewable energy, Stand-alone, control strategies.*

I. INTRODUCTION

The solar and wind pv hybrid generation system then this output synchronis with grid as the voltage and frequency. The combination of hybrid solar and wind power systems into the grid can further help in improving the overall economy and reliability of renewable power generation to supply its load. Similarly, the integration of hybrid solar and wind power in a stand-alone system can minimize the energy storage size needed to supply continuous power.the combined solar and wind system into grid can help to minimum cost and improving reliability of power generation to supply its load. The stand-alone systems can be sub-classified into common DC bus or common AC bus. Distributed generators can help fluctuations in power supply since generations' units will be close to the loads. Combining both PV solar and wind powers can minimize the storage requirements and ultimately the overall cost of the system. Increasing PV panels and capacity of wind turbines could be a better option compared to the increasing of batteries since batteries are much more expensive with a shorter lifespan compared to the life time of a PV or WT. The increased penetration of grid-connected renewable energy sources has an impact on the grid power quality in particular weak grids. Voltage fluctuation, frequency fluctuation and harmonics are major power quality issues. Furthermore, intermittent energy from solar PV and wind has a huge impact on network reliability. However, accurate forecasting and scheduling systems can minimize the impacts. Various statistical forecasting and regression

analysis approaches and algorithms are used to forecast weather pattern, solar radiation and wind speed .This paper aims at the averaged modelling and energy flow analysis of a stand-alone hybrid generating system comprising of wind and photovoltaic subsystem . the average model is used because it's adequate for long time dynamic simulation. Both, photovoltaic and wind conversion subsystem are modelled and simulated integrating chopper losses. A mathematical modelling and analysis of energy losses involved with power conditioners converters is particularly developed. As well, the design and the dimensioning of buck power components (inductor, capacitor) are presented for each subsystem.

Maximum power point tracking (MPPT) controllers are used in photovoltaic and wind subsystem to maximize respectively the photovoltaic array and the wind generator output power , irrespective of the climatic conditions(temperature,irradiation and the wind velocity) and of the load electrical characteristics. The individual system are simulated for varying wind velocities and solar intensities respectively and the result are used to identify the performance of hybrid system.

II .PROPOSED METHODOLOGY

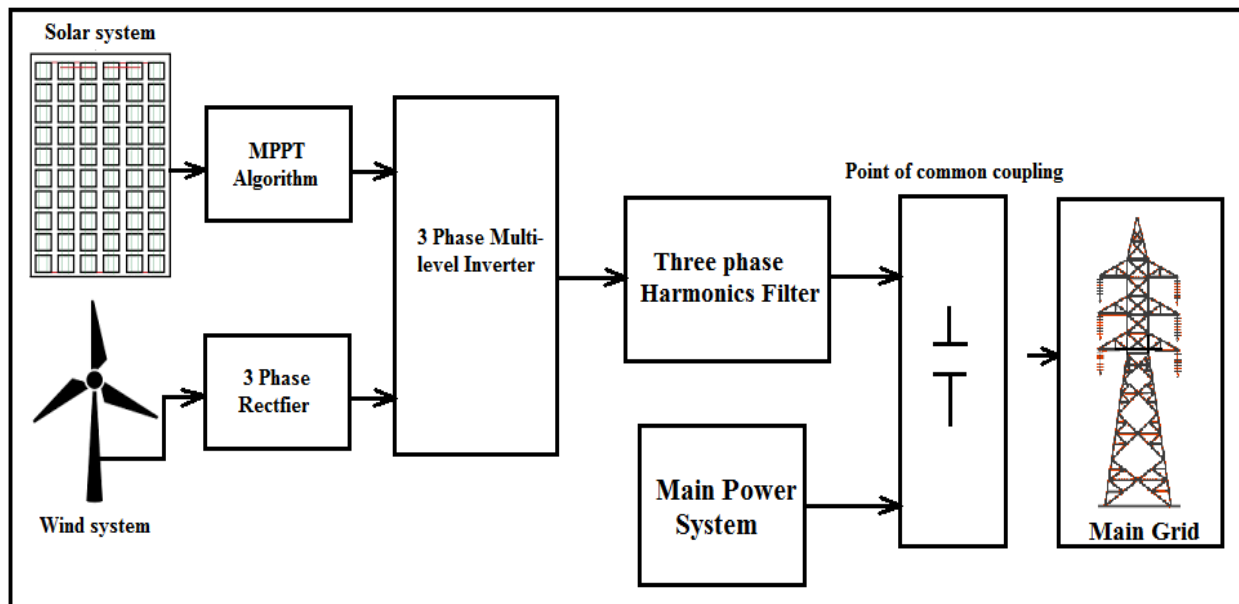

Figure II.1 : Block diagram of proposed methodology

In this system there is a wind turbine, the output of the wind turbine goes to permanent magnet synchronous generator. The output of the wind system is in ac so we need ac to dc converter to convert the ac output in to dc .Similarly in the PV side the output of the PV array is connected with a dc-dc boost converter to rise the output voltage up to a desire level. And the output of PV and wind are connected with a common DC link voltage. The common DC link voltage will be connected with the DC to AC converter and the output of the inverter is synchronizing with grid. This inverter changes DC power from PV array and the wind turbine into AC power and it maintain the voltage and frequency is equal to the grid voltage and frequency.

The explanation of each blocks are following ways:

Solar cell: PV array are formed by combine no of solar cell in series and in parallel. A simple solar cell equivalent circuit model is shown in figure. To enhance the performance or rating no of cell are combine. Solar cell are connected in series to provide greater output voltage and combined in parallel to increase the current. Hence a particular PV array is the combination of several PV module connected in series and parallel. A module is the combination of no of solar cells connected in series and parallel.

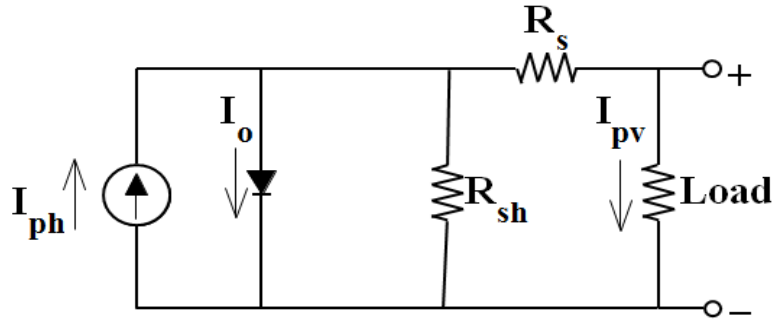

Figure II.2 : Circuit diagram of a single PV cell

Photo-current of the module:

$$I_{ph} = [I_{scr} + k_i(T - 298)] * \lambda / 1000$$

Reverses saturation current of the module:

$$I_{rs} = I_{scr} / [\exp (qV_{oc} / N_s kAT) - 1]$$

Saturation current of the module:

$$I_o = I_{rs} \left[\frac{T}{T_r} \right]^3 \exp \left[\frac{qE_{go}}{BK} \left\{ \frac{1}{T_r} - \frac{1}{T} \right\} \right]$$

The current output of PV module:

$$I_{pv} = N_p \times I_{ph} - N_p * I_o \left[\exp \left\{ \frac{q * V_{pv} + I_{pv} R_s}{N_s A K T} \right\} - 1 \right]$$

This equation is used to simulate in mat lab/Simulink and the result shows the nonlinear characteristics of photovoltaic array at different irradianations and temperature.

Wind system: Wind is a form of solar energy and it is available everywhere. Always wind blows from a higher atmospheric pressure region to the lower atmospheric pressure region due to the non uniform heat by the sun and due to the rotation of the earth. In other wards we can say that wind is a form of solar energy available in the form of that kinetic energy of air.

By using the power of the wind turbines produce electricity by drive an electrical generator. A moving force is exerted and generates lift when wind is passing over the blades. The rotating blades rotate the shaft which is connected with the gearbox. The gearbox adjusts the rotational speed which is convenient for the generator to get a desired output. The output of the wind generator is fed to the transformer which converts the electricity of the generator up to 33 kv which is the appropriate voltage for power system. From the swept area of the blades a wind turbine extracts kinetic energy. So the power contained in the wind is given by the kinetic energy of the flowing air mass per unit time.

$$\begin{aligned}
 P_0 &= \frac{1}{2} (\text{air mass per unit time})(\text{wind velocity})^2 \\
 &= \frac{1}{2} (\rho AV_w)(V_w)^2 \\
 &= \frac{1}{2} \rho AV_w^3 \\
 p &= 0.5 \rho A c_p V_w^3
 \end{aligned}$$

Where

$$\rho = \text{Airdensity}(kg/m^3)$$

$$A = \text{sweptareaofturbine}$$

$$V_w = \text{windspees}(m/sec)$$

$$C_p = \text{powercoefficient}$$

$$C_p \left(\frac{\lambda}{\beta} \right) = C_1 \left(\frac{C_2}{\lambda_i} - C_3 \beta - C_4 \right) e^{-\frac{C_5}{\lambda_i}} + C_6 \lambda$$

With,

$$\frac{1}{\lambda_i} = \frac{1}{\lambda + 0.08\beta} - \frac{0.035}{\beta^3 + 1}$$

Where,

$$C_1 = 0.5176, C_2 = 116, C_3 = 0.4, C_4 = 5, C_5 = 21, C_6 = 0.0068$$

Some terms frequently used in the wind energy are

III . MAXIMUM POWER POINT TRACKING ALGORITHM FOR SOLAR SYSTEM

In solar panel peak power is archived with the help of a DC-DC boost converter and it is used in between the PV generator and the load by adjusting the duty cycle. Maximum Power Point of a solar module varies with the variation of irradiation and temperature So MPPT algorithms are necessary in PV applications because by the use of MPPT algorithms it obtain the peak power from the solar panel. Previously there are different methods to find the MPP have been published and developed. According many aspects these techniques differ such as required sensors, complexity, range of effectiveness, according to speed, cost, if there is change in irradiation and temperature than also the effectiveness of tracking, requirement of hardware and its implementation. 19 different MPPT algorithms are there among these techniques, the Incremental conductance algorithms and the P&O algorithms are generally used. This is easy to use and simple in operation and required less hardware as compare to other. When there is more than one MPP other MPPT technique are used and it appeared generally when the PV array is partially shaded.

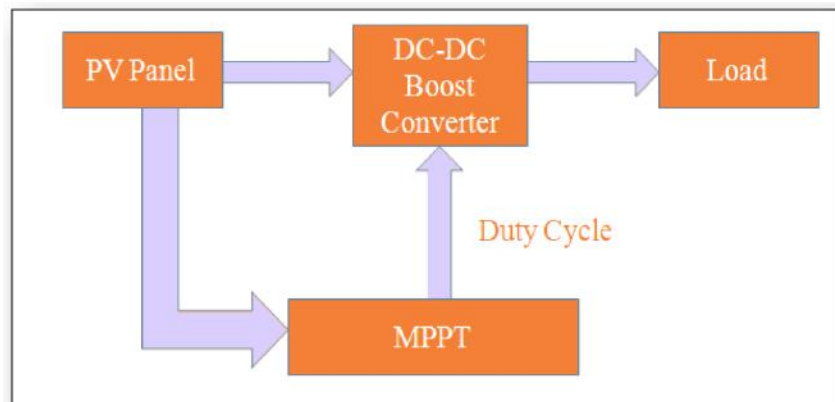

**Figure III :Circuit Arrangement of MPPT
Three phase LC filter (For Harmonics reduction)**

In grid synchronization due to the PWM inverter ripple current is injected to the grid to overcome this problem LC filter is used. Based on the current ripple the value of L is design. Due to the lower switching smaller ripple result. The change in current is 10% to 15% of the rated value. In this system 10% of the rated current can be considered for the designed value of the inductor L.

$$\Delta i_{max} = \frac{1}{8} * \frac{V_{dc}}{L * f_s}$$

For reactive power supplied from the capacitor at fundamental frequency the capacitor C is designed. So due to the design of reactive power 15% of the rated power is to be taken.

$$C = 15\% * \frac{P_{rated}}{3 * 2\pi f * V_{rated}^2}$$

IV. MATLAB SIMULATION MODEL

Electrical power systems are combination of electrical circuits and electromechanical devices like motors and generators. Engineers working in this discipline are constantly improving the performance of the systems. Requirements for drastically increased efficiency have forced power system designers to use power electronic devices and sophisticated control system concept that tax traditional analysis tools and techniques. Further complicating the analyst's role is the fact that the system is often so nonlinear that the only way to understand it is through simulation. Land-based power generation from hydroelectric, steam, or other devices is not the only use of power systems. A common attribute of these systems in their use of power electronics and control systems to achieve their performance objectives.

SimPowerSystems software is a modern design tool that allows scientists and engineers to rapidly and easily build models that simulate power systems. It uses the Simulink environment, allowing you to build a model using simple click and drag procedures. Not only can you draw the circuit topology rapidly, but your analysis of the circuit can include its interactions with mechanical, thermal, control and other disciplines. This is possible because all the electrical parts of the simulation interact with the extensive Simulink modelling library. Since Simulink uses the MATLAB computational engine designers can also use MATLAB toolboxes and Simulink block sets. SimPowerSystem software belongs to the Physical Modeling product family and uses similar block and connection line interface.

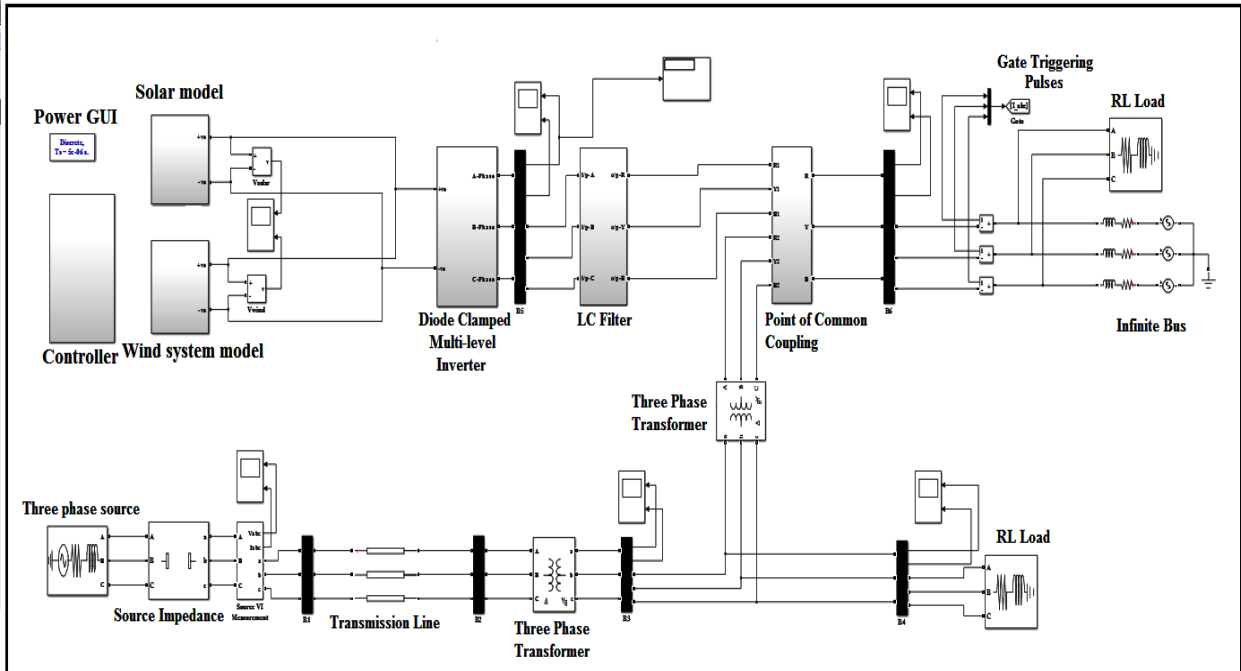

Figure IV Matlab simulation model of Hybrid power system

IV RESULT

Solar and wind system output

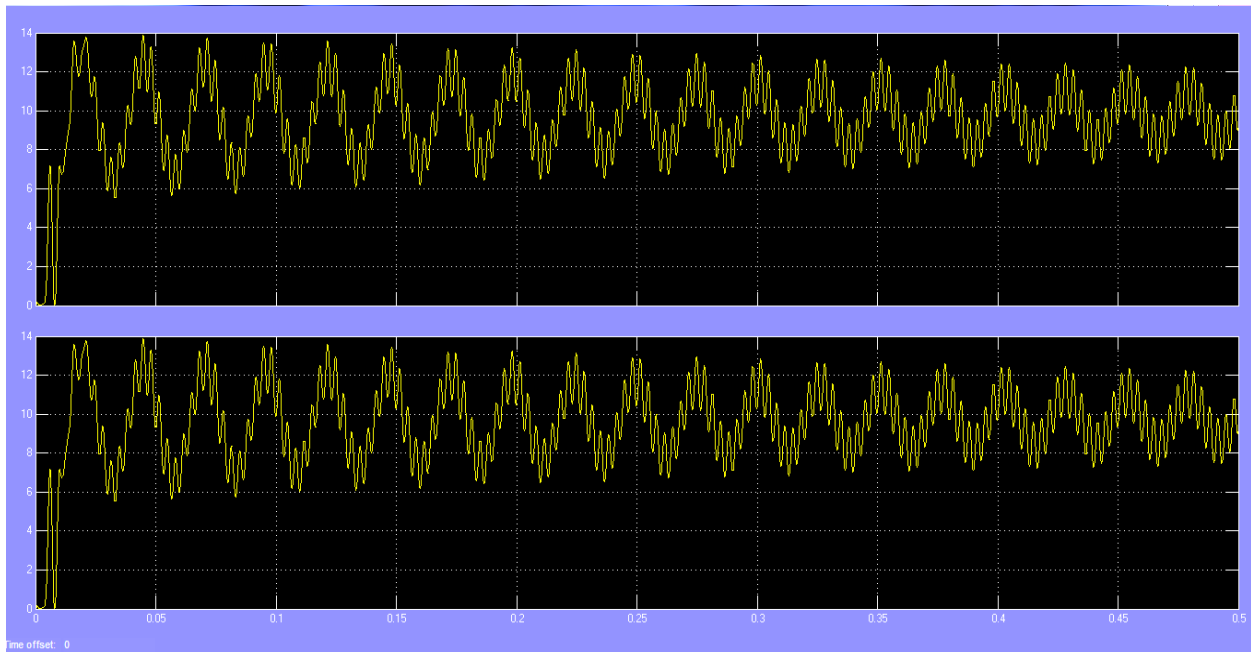

Figure IV.1: Generated output DC voltage at Solar and wind system output

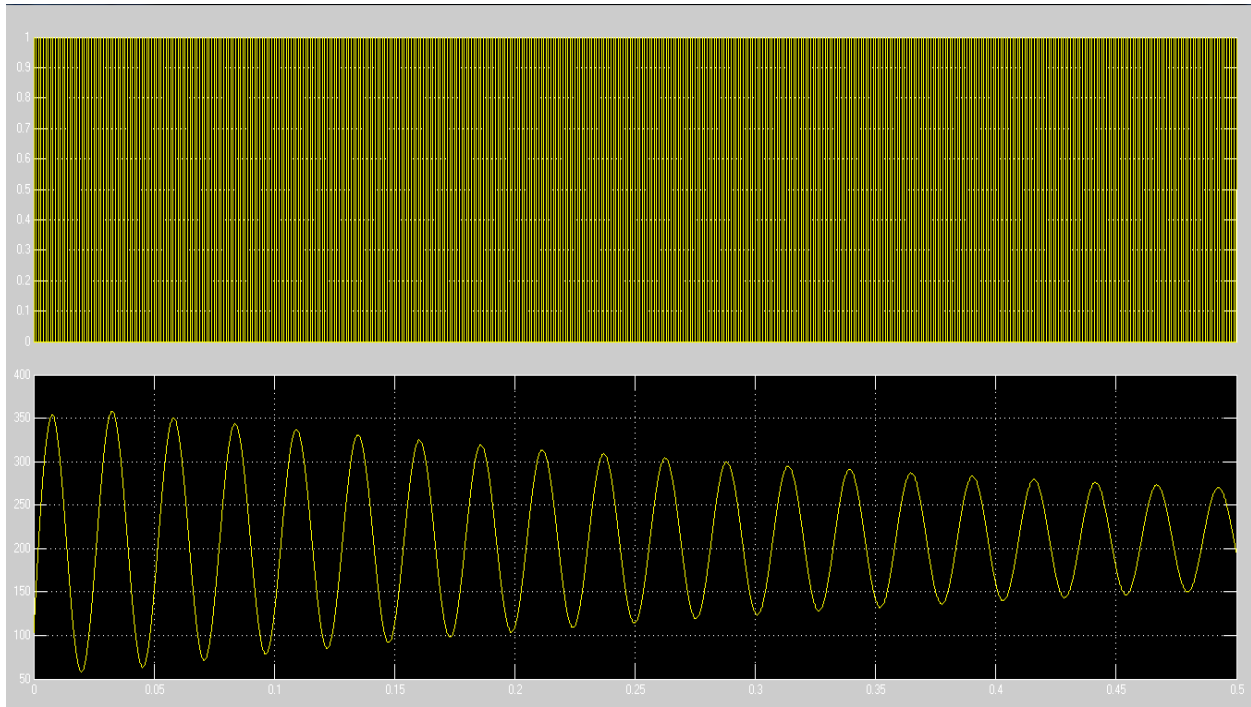

Figure IV.2: Solar system output without MPPT algorithm and with MPPT algorithm.

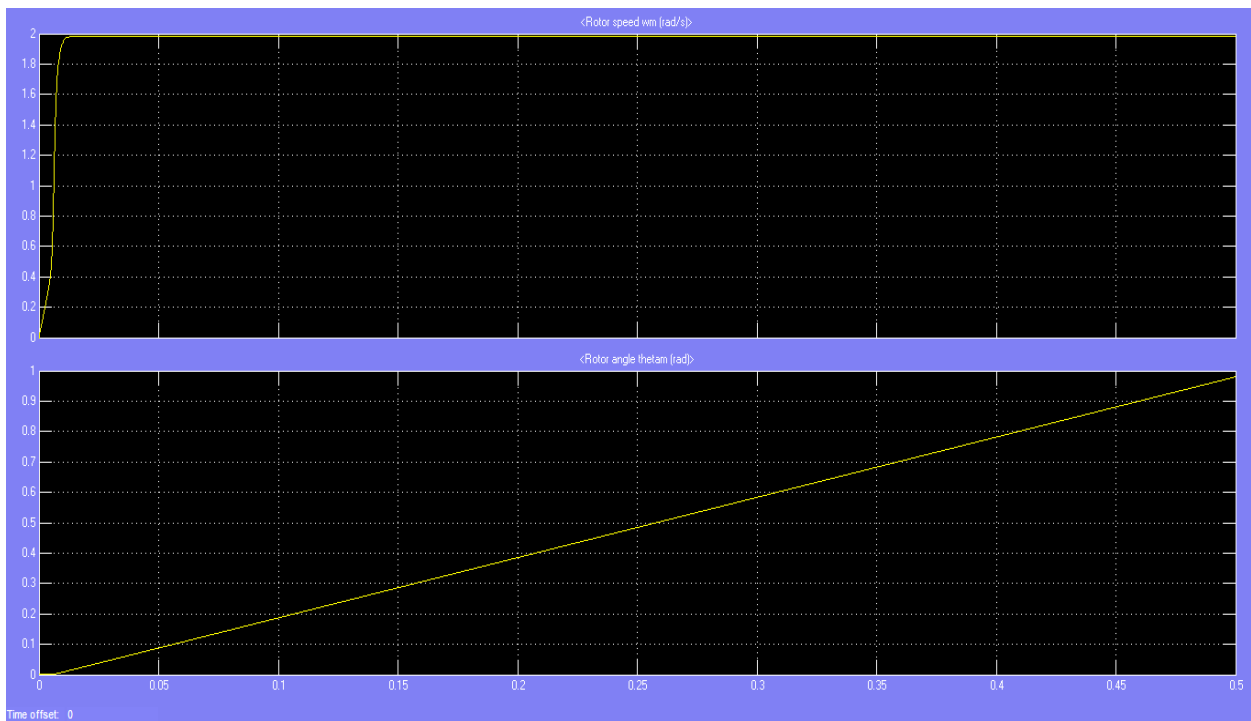

Figure IV.3: Wind turbine performance parameter rotor speed and corresponding rotor angle in rad.

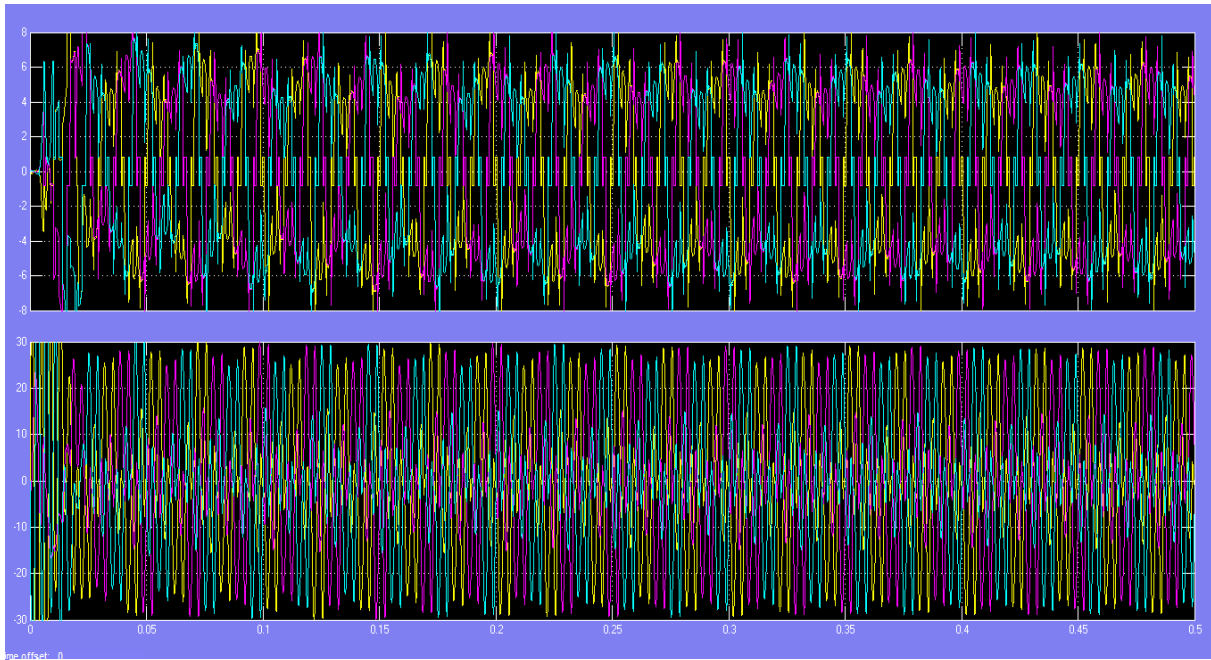

Figure IV.4: Multilevel inverter output voltage and current with harmonics content due to switching effect.

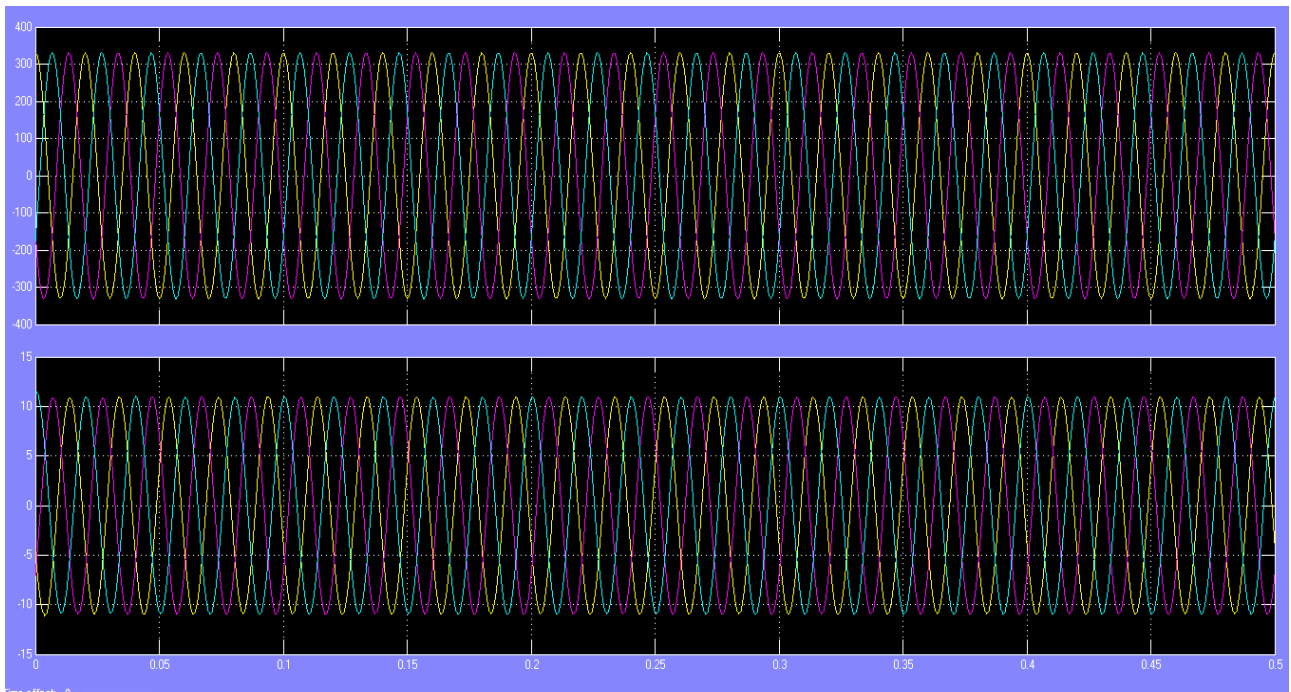

Figure IV.5: Voltage and current waveform after LC filter.

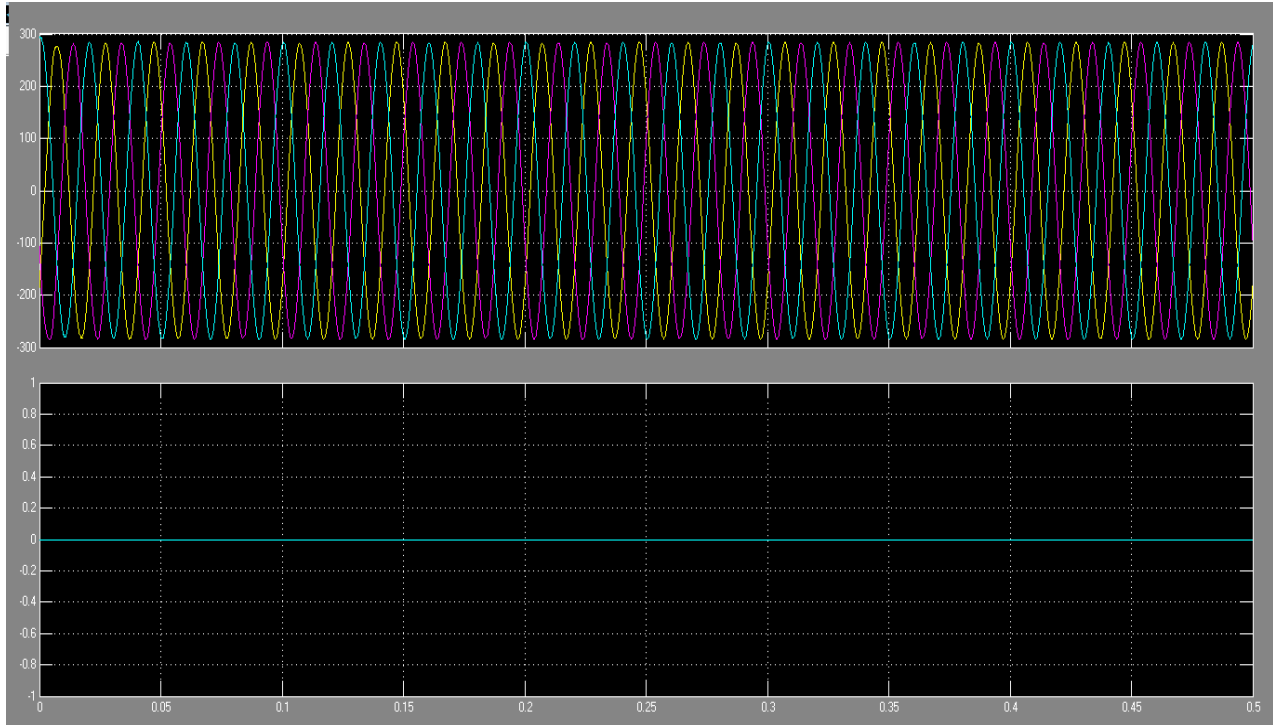

Figure IV.6: Voltage and current waveform at three phase source.

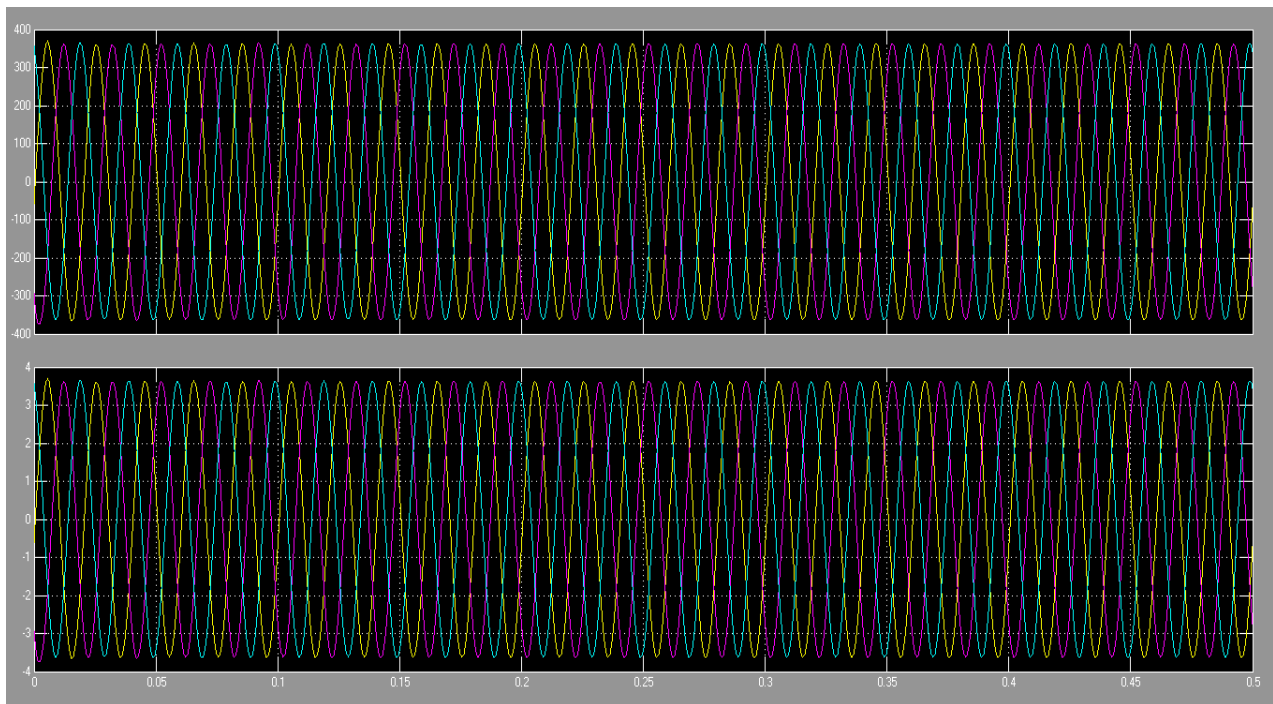

Figure IV.7: Voltage and current waveform of main bus bar (Infinite bus).

V . CONCLUSION

This paper give an overview of different research works related to control for grid-connected and stand-alone hybrid solar PV and wind systems. Solar PV and wind hybrid system can be connected in a common DC or common AC bus whether they are working in a grid-connected mode or a stand-alone mode. In this project for comparing these two algorithms three series model and six parallel model is taken and simulated in Matlab/Simulink. From the simulation result it is observed that both the method give nearly same result. So the P&O method is chosen for the grid synchronization purpose because of its simplicity and easy implementation. A dynamic model of wind turbine is model and simulated. PMSG is used in this paper as a wind generator due to its self excitation capabilities and requires less maintain. A 6kW out power is generated from the PMSG. A greed side VSI is used to synchronize the wind-PV hybrid system. The various waveform of this system were obtained by using the software Matlab/Simulink. The simulation result showed excellent performance and the DC linked voltage is able to maintain at a constant level at 640 V from the wind -PV hybrid system with varying condition of wind and with different irradiation and temperature. In future we can combine other hybrid system with this existing one like fuel cell or battery system can be added and by using matlab it can be analyzed. The work was carried out by doing extensive research and by using a design process to implement each system individually. Testing and development through understanding was also a significant part of this work.

VI . REFERENCES

1. M. Brower, E. M. Galán, J. F. Li, D. Green, R. Hinrichs- rahlwes, S. Sawyer, M. Sander, R. Taylor, H. Kopetz, and Gsänger, "Renewables 2014 global status report," REN21 2014
2. J. H. R. Enslin, "The role of power electronics and storage to increase penetration levels of renewable power," *Power and Energy Society General Meeting - Conversion and Delivery of Electrical Energy in the 21st Century*, IEEE Press, pp. 1-2, July (2008) DOI: 10.1109/PES.2008.4596958
3. O. Edenhofer, R. Pichs-Madruga and T. Sokona, Eds., "Renewable energy sources and climate change mitigation," *SRREN_FD_SPN_Final Report*, <http://www.ipcc.ch/report/srren/>, (2012)
4. A. Luque and S. Hegedus, Ed., *Handbook of photovoltaic science and engineering* (Wiley, Chichester, 2003)
5. B. Parida, S. Iniyar, and R. Goic, "A review of solar photovoltaic technologies" *Renewable and Sustainable Energy Review*, **15**, 1625-1636 (2011) DOI: 10.1016/j.rser.2010.11.032
6. S. Kurtz, "Opportunities and challenges for development of a mature concentrating photovoltaic power industry," *Technical Report NREL/TP-520-43208, Revised November* (2009)
7. EPTP, "A strategic research agenda for photovoltaic solar energy technology," September (2011) [second edition]
8. J. Karp, "Concentrating solar power: progress and trends," *Jacobs School of Engineering, University of California San Diego, Triton SPIE/OSA, February 12* (2009) [http://psilab.ucsd.edu/research/Multiband%20Solar%20C concentration/files/UCSD_CPV.pdf](http://psilab.ucsd.edu/research/Multiband%20Solar%20C%20concentration/files/UCSD_CPV.pdf)
9. L. Micheli, N. Sarmah, X. Luo, K. S. Reddy, and T. K. Mallick, "Opportunities and challenges in micro- and nano-technologies for concentrating photovoltaic cooling: A review"
10. H. Zhang and L. L. Lai, "Research on wind and solar penetration in a 9- bus network" *Proc. IEEE Power and Energy Society General Meeting*, IEEE Press, pp. 1-6, July (2012) DOI: 10.1109/PESGM.2012.6345218
11. P. Komor, "Wind and solar electricity: challenges and opportunities," *University of Colorado at Boulder, Pew Center on Global Climate Change, June* (2009).