

Chief Editor

Dr. A. Singaraj, M.A., M.Phil., Ph.D.

Editor

Mrs.M.Josephin Immaculate Ruba

EDITORIAL ADVISORS

1. Prof. Dr.Said I.Shalaby, MD,Ph.D.
Professor & Vice President
Tropical Medicine,
Hepatology & Gastroenterology, NRC,
Academy of Scientific Research and Technology,
Cairo, Egypt.
2. Dr. Mussie T. Tessema,
Associate Professor,
Department of Business Administration,
Winona State University, MN,
United States of America,
3. Dr. Mengsteab Tesfayohannes,
Associate Professor,
Department of Management,
Sigmund Weis School of Business,
Susquehanna University,
Selinsgrove, PENN,
United States of America,
4. Dr. Ahmed Sebihi
Associate Professor
Islamic Culture and Social Sciences (ICSS),
Department of General Education (DGE),
Gulf Medical University (GMU),
UAE.
5. Dr. Anne Maduka,
Assistant Professor,
Department of Economics,
Anambra State University,
Igbariam Campus,
Nigeria.
6. Dr. D.K. Awasthi, M.Sc., Ph.D.
Associate Professor
Department of Chemistry,
Sri J.N.P.G. College,
Charbagh, Lucknow,
Uttar Pradesh. India
7. Dr. Tirtharaj Bhoi, M.A, Ph.D,
Assistant Professor,
School of Social Science,
University of Jammu,
Jammu, Jammu & Kashmir, India.
8. Dr. Pradeep Kumar Choudhury,
Assistant Professor,
Institute for Studies in Industrial Development,
An ICSSR Research Institute,
New Delhi- 110070, India.
9. Dr. Gyanendra Awasthi, M.Sc., Ph.D., NET
Associate Professor & HOD
Department of Biochemistry,
Dolphin (PG) Institute of Biomedical & Natural
Sciences,
Dehradun, Uttarakhand, India.
10. Dr. C. Satapathy,
Director,
Amity Humanity Foundation,
Amity Business School, Bhubaneswar,
Orissa, India.



ISSN (Online): 2455-7838

SJIF Impact Factor (2015): 3.476

EPRA International Journal of

Research & Development (IJRD)

Volume:1, Issue:7, September 2016



Published By :
EPRA Journals

CC License





A REVIEW ON THREE-PHASE INDUCTION MOTOR USING CARRIER BASED SPACE VECTOR PULSE WIDTH MODULATION TECHNIQUE ENERGIZED FROM SOLAR CELLS

Anamika Dewangan¹

¹M Tech Scholar, Electrical Engineering (Power System), Arya College of Engineering And Information Technology, Kukas, Rajasthan, India.

Balram Kasniya²

²Assistant Professor, Electrical Engineering(Power System), Arya College of Engineering and Information Technology, Kukas, Rajasthan, India.

ABSTRACT

This paper presents an overview of space vector PWM with various types of control schemes in large amount for controlling the velocity of Induction motor. Various methods are available for controlling the velocity of Induction motor. Based on reliability and compatibility the carrier based space vector method is used. It produces waveform with less harmonic content and work on the principle of pulse width modulation. Generation of pulses by this method gives ripple less waveform and less harmonic content closely to pure sinusoidal waveform. Controlling of speed is accomplished by adjusting the frequency of stator voltage based on V/f method. Because of Easier digital implementation and control capability with efficient Dc bus utilization this method become superior amongst all other that use to control the velocity of induction motor (IM). This paper mainly reveals on an overview of implementation of Carrier based SVPWM with induction motor.

KEYWORDS: Pulse width modulation (PWM), SPWM (Sine pulse width modulation), SVPWM (Space Vector pulse width modulation), DC (Direct current), AC (Alternating current), IM (Induction motor)

I. INTRODUCTION

The electrical dc (direct current) drives are less reliable than the ac drives (alternating current) but they are still used in wide range because their simple construction and high efficiency. The ac drives are more reliable than the dc drives but more expensive and having complex structures. Induction motor (IM) is a type of AC drives which transform electrical energy into mechanical energy and vice versa. Induction motors becomes most popular for industrial application due to

their less maintenance and advanced performance in both production as well as service application.

In Induction motor conversion of power is made through electromagnetic induction. The induction motor with rolled up rotor was invented by Nikola tesla in 1882 in France but initial patent was issued in 1888. In his research work, Tesla laid the establishment for understanding the way how motor operates. The induction motor with a cage was invented by Mikhail Dolivo - Dobrovolsky about after a year in

Europe. Development of technology has improved where a 100 HP (74.6 KW) motor from 1976 takes the same volume as a 7.5 HP (5.5 KW) motor did in 1897. presently; the most common induction motor is the cage rotor motor. The induction motors are cheap machines based on their construction because it is constructed without slip rings and commutators. These advantages developed the electrical drives with an execution of induction machine for starting, braking, velocity reversal and velocity change etc. There are two control techniques for induction motor are analogue and digital. Analogue is method based on direct calculation of the system parameters (mainly the rotor velocity). While digital is the approximate calculation of the machine parameters in the sensorless control schemes, with the implementation methods Slip frequency measurement method, velocity calculation using state equation, approximate calculation based on slot distance harmonic voltages, flux calculation and flux vector control, straight control of torque and flux, perceiver based velocity sensorless control, modern reference adoptive system, kalman purifying techniques, sensorless control with parameter adoption, nerves network based sensorless control, fuzzy-technique based sensorless velocity control. Based on control signal, control techniques of induction motor are again classified by Holtz in 1998 are scalar control and vector control [1]. Scalar control (volts per hertz management) and vector control (direct torsion control and field orienting control) are further classified in two types: Scalar control is classified as potential/wave (or v/f) control and Stator current control and slip wave control. Those are mainly connected through direct measurement of machine parameters. Whereas vector control is classified as Field orientation control (FOC), direct torque (DTC) and stator flux vector control. Stator flux vector control is realized both in analogue (direct measurement) and digital version (estimation techniques).

The switching techniques used in fluctuating speed drives are of various types are 6 step switching technique, selected-harmonic removable pulse width modulation, delta pulse width modulation, low-ripple current pulse width regulation and sinusoidal pulse width regulation etc [2]. The selection is based on suitability and compatibility of devices. Among all control techniques direct torque control is efficient one used to mitigate torque harmonics by estimating a reference stator voltage then space vector modulation technique is used to modulate the obtained output. The generation of pulses are done by this method with constant switching frequency and used to drive gates of the power inverter for supplying voltage to an induction motor. Pulse width regulation method is broadly used in power electronic devices by which a static potential is given to inverter and modified ac output is obtained by varying on and off periods of inverter.

There are variety of method to achieve require torque and controlled speed. The carrier based distance

vector pulse width modulation is most broadly used as a result of higher effective over the other approaches [3]. It gives greater level of foremost voltage and enables use of voltage and neatly works with vector manage and gives much less whole Harmonic Distortion (THD), higher PF and less switching losses at high frequencies [4][5][6]. SVPWM is used to compute duty cycle of the switches and probably the most evolved characteristic of SVPWM are easy digital implementation and broad linear modulation variety for output line-to-line voltages [7]. However, a trouble of SVM is that it requires problematic online computation that usually limits its operation most effective up to several kilohertz of switching frequencies. But it can be increased with the aid of making use of high speed DSP and simplifying computation with the support of look up tables which may be very huge and tends to cut back the heart beat width solution [8]. Block diagram of Implementation of Induction motor drive with space vector pulse width modulation is shown in Fig. 1.

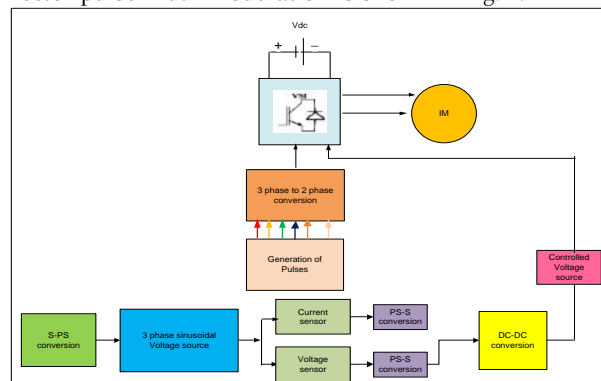

Fig. 1. Block diagram of implementation of Induction motor with carrier based space vector PWM

II. MULTI-LEVEL INVERTER

To fulfill the partial energy specifications, variable resistance there are two types of inverters single-phase potential source inverters and three-phase potential source inverters. For large power drives three-phase inverters are used. We are working on three -phase potential source inverter which are also referred as multi-level inverter. Three-phase inverters are used to provide adjustable-frequency power to industrial applications and working in medium to high energy range but single-phase inverter works on low energy range. It takes dc power supplies from a battery and gives a three-phase potential source where amplitude, phase and wave of voltages are controllable. Although demand of sinusoidal voltage waveforms is high in all application like Adjustable speed drives, UPS, FACTS, VAR compensators etc. arbitrary voltages are also required in some applications like active filters, voltage compensator etc. that's why the demand of three-phase are inverters are higher than the single-phase inverters.

The circuit diagram of 3-phase VSI is shown in Fig. 2 effective switch periods are given in Table 1.As in single-phase VSI, 2 switches in same branch do not conduct simultaneously as they result short circuit. Similarly in order to escape undefined periods in inverter, the switches of any leg of inverter cannot be switch off simultaneously as this will result in potential that will base upon the respective line current sign. Table 1 shows 8 effective switch states in which 2 out of 6 produces zero output and remaining states produce non-zero output. The inverter moves from one state to another state in order to produce required output so that the resultant alternating current output line potential consist of non continuous i.e. distinct values of potential that are V_i , 0, $-V_i$ shown in Fig. 2. The choice of period in order to generate the required output and waveforms is obtained by the regulating technique. The regulating techniques which is used to produce pulses are pulse width modulation.

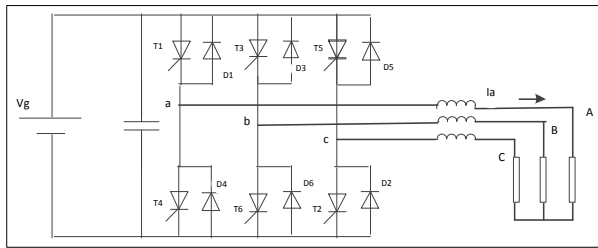

Fig.2. Circuit diagram of 3-phase bridge inverter

State	state	V_{ab}	V_b	V_a	Space vector
1,2 and 6 are on and 4,5 and 3 are off	1	v	0	-v	V_1
2,3 and 1 are on and 5,6 and 4 are off	2	0	v	-v	V_2
3,4 and 2 are on and 6,1 and 5 are off	3	-v	v	0	V_3
4,5 and 3 are on and 1,2 and 6 are off	4	-v	0	v	V_4
5,6 and 4 are on and 2,3 and 1 are off	5	0	-v	v	V_5
6,1 and 5 are on and 3,4 and 2 are off	6	v	-v	0	V_6
1,3 and 5 are on and 4,6 and 2 are off	7	0	0	0	V_7
4,6 are 2 are on and 1,3 and 5 are off	8	0	0	0	V_8

Table 1. Switch States Of Three-Phase Bridge Inverter

III. PULSE WIDTH MODULATION

The PWM inverter is highly used in industries. PWM inverter is a kind of inverter that control output voltage by using itself. PWM techniques are characterized by way of regular amplitude pulses. To receive output voltage manage, the width of these pulses are modulated and in addition remove the harmonic content. In this process, a fixed dc value is fed to the inverter and a controlled ac output potential is obtained by changing on and off states of the inverter component. PWM systems are of three varieties as listed below:

- (a) Single pulse modulation
- (b) Multiple pulse modulation
- (c) Sinusoidal pulse modulation (carrier based PWM)

In PWM inverter force commutation is essential. The duty cycle is a measure of the time of the regulated signal is in the ‘high’ state. It is generally recorded as the percentage of the signal period where the signal is considered on (in Fig. 3)

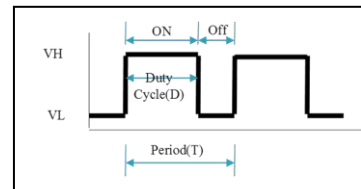

Fig. 3. On-Off period of duty cycle

Duty cycle is determined by:

$$\text{Duty cycle} = \frac{\text{On time}}{\text{period}} * 100$$

In PWM, cycle is adjusting to deliver the information over a communication channel or manage the amount of energy sent to a load. PWM enables use of square wave whose duty cycle is adjusting within variable waveform. When we recalling rectangular waveform $F(t)$ with low value, we will get Y_{min} while calling high value Y_{max} will get. The natural value of waveform is given as

$$\bar{y} = \frac{1}{T} \int_0^T f(t) dt$$

Whereas the period of Y_{max} is $0 < t < D.T$ and Y_{min} is $D.T < t < T$ which gives resultant expression

$$\begin{aligned} \bar{y} &= \frac{1}{T} \left(\int_0^{DT} Y_{max} dt + \int_{DT}^T Y_{min} dt \right) \\ &= \frac{D.T.Y_{max} + T(1-D)Y_{min}}{T} \\ &= D.Y_{max} + (1-D)Y_{min} \end{aligned}$$

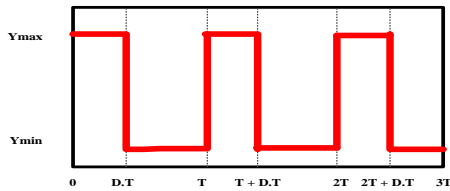

Fig 4. Square wave of Ymin, Ymax and D

IV. TYPES OF SPEED CONTROL METHOD

- (a) Analog generation method
 - Intersective method
- (b) Digital generation method
 - Delta modulation
 - Delta sigma modulation
 - Space vector modulation
- (c) Application specific method
 - Direct torque control
 - Time proportioning

(a) Analog generation methods

Through sawtooth or triangle waveform (can effortlessly generate making use of a easy oscillator) and comparator, it is convenient to generate PWM signal and the procedure that makes use of best these element are referred to as Intersective system. On this system reference signal is examine with modulating waveform. On bases of assessment output is received. If reference sign (crimson sine wave in Fig. 5) is more than the regulation waveform (blue), the PWM sign (magenta) is in high state, in any other case it's in low state. The length of pulses is stylish upon the intersection of the reference sinusoidal and set off sign. When the sinusoid is better than the sign, the PWM pulse is switched to on/high function. When the sinusoid is not up to the signal the PWM pulse is switched to the off/low role.

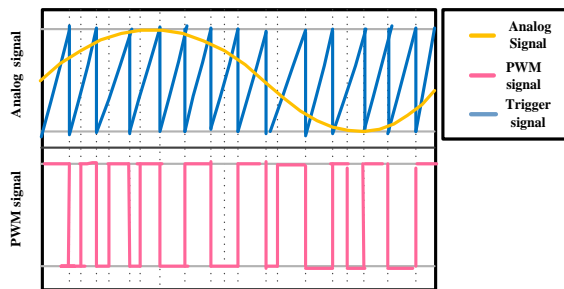

Fig 5. Pulse generation by Intersective method

(b) Digital generation methods

(i) Delta modulation

Here the output signal is compared with limits, which correspond to a reference signal offset with the aid of a steady as proven in Fig. 6. To generate output the PWM sign changes its state and the output sign reaches probably the most limits. The output is built-in and will

broaden or slash toward the restrict set across the reference by a consistent offset. At any time when the output comes into contacts with one of the crucial limits across the reference, the PWM sign will swap modes.

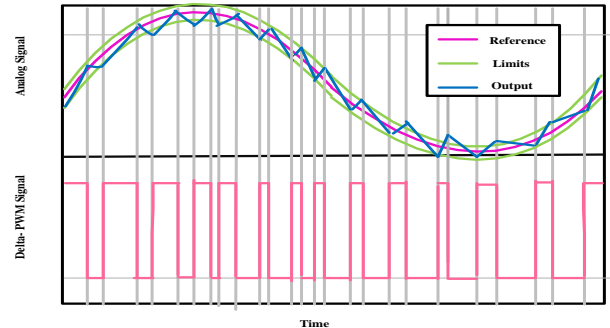

Fig. 6. Pulses of delta modulation

(ii) Digital sigma method

In this approach to type an error, the output sign is subtracted from a reference sign. This error is built-in, and when the necessary of the error more than the limits, the output changes state (Fig.7).

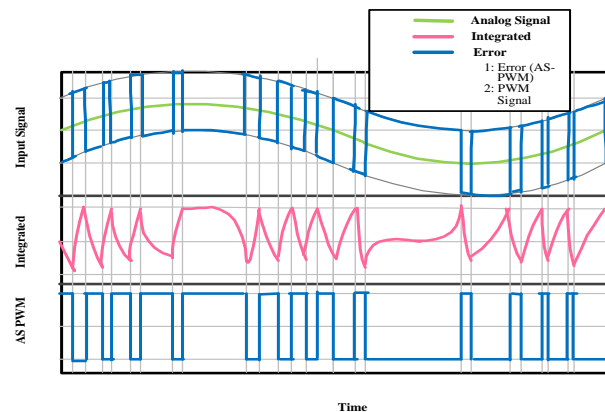

Fig. 7. digital sigma method

(iii) Space vector modulation

For new release of multiphase AC house vector regulation is used. Where reference signal is specimen in standard bases after each and every sample, non-zero agile switching vectors adjoining to the reference vector and a number of of the zero switching vectors are chosen for the suited bit of the specimen interval with the intention to combine the reference indicator as the average of the used vectors.

(c) Application specific method

(i) Time proportioning

Many digital circuit can generate PWM signals(e.G., many microcontroller have PWM output)by the use of counter that increments periodically (connected

directly or indirectly to the clock circuit) and is reset at the end of each interval of PWM. When the counter worth is greater than the reference price, the PWM output alterations acknowledged from high to low or low to excessive. This procedure is called as time proportional technique.

(ii) Direct torque control

In this method, it is used to regulate AC motors. Its is carefully concerning delta modulation motor torque and magnetic flux are calculated and are regulated to stay inside their hysteresis bands by means of rotating on new blend of device's semiconductor switches whenever any one of the sign tries to turn away out of the band.

V. SPACE VECTOR PULSE WIDTH MODULATION

Space vector PWM can be implemented in the motor by different types. Method is selected based on suitability, capability of drive and according to requirement of torque. Space vector PWM method is applied on multi level inverter to produce ripple free harmonics and velocity control of induction motor. There are various types of SVPWM implementation techniques are as

- a) Sector selection based SVM
- b) Reduced switching SVM
- c) Carrier based SVM
- d) Reduced changing states carrier based SVM

a) Sector selection based SVPWM

This method provides mitigate generated output by the selection of sector using the simulink block and s-functions algorithm we can build up new system as shown in Fig. 8

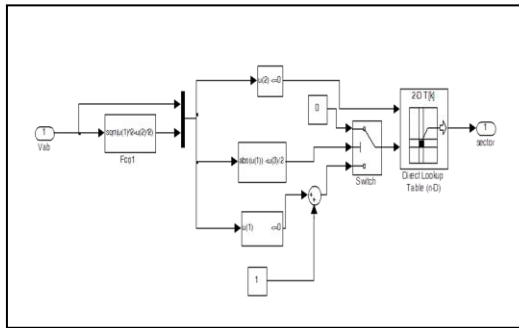

Fig. 8. A sector selection algorithm

b) Reduced switching SVPWM

By selecting one of zero vectors during each sector the switching steps of the IGBT can be reduced by 33%. The implementation is shown in fig. below.

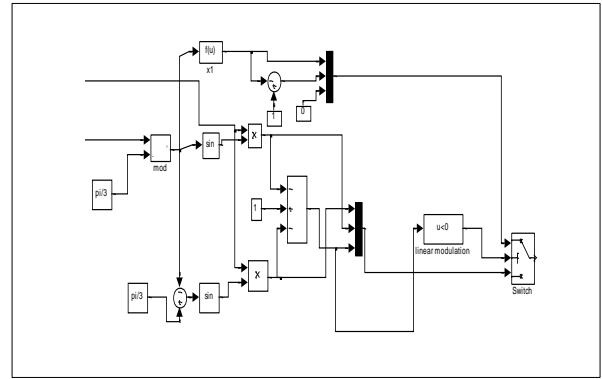

Fig. 9. Deriving the weights of the adjacent non-zero basic vector

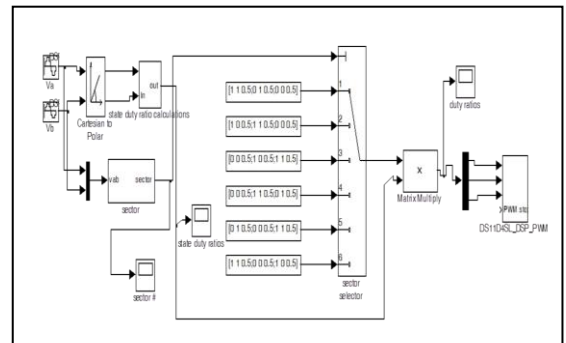

Fig. 10. Space vector modulation Simulink model

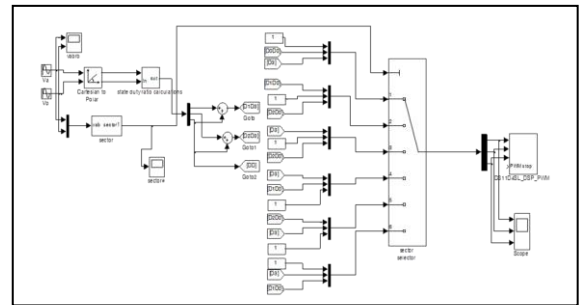

Fig. 11. Reduced switching space vector modulation

c) Carrier based SVPW

Carrier based space vector modulation method works on without sector determination consequently; it comes under easier method compare to other methods. In this method obligation ratio profile are compared to generate pulses. By generating pulses high triangular wave pulses are generated. It is efficient and effective method comparing to others. Waveforms are shown in Fig. 12 and Fig. 13 and implementation of motor with method is shown in Fig. 14, Fig. 15.

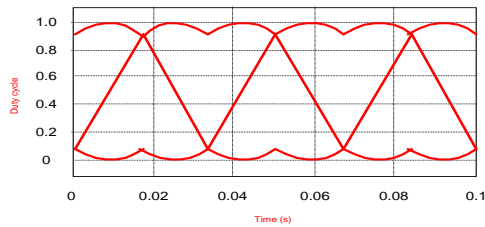

Fig. 12. Duty ratio profile with standard SVPWM

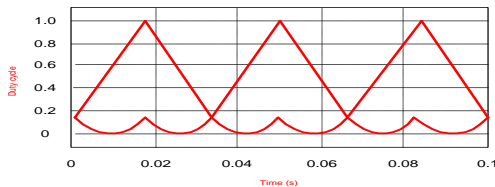

Fig. 13. Duty ratio profile with reduced switching SVPWM

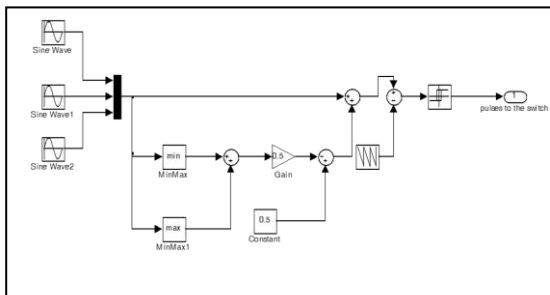

Fig. 14. Carrier based space vector modulation based on common mode voltage addition

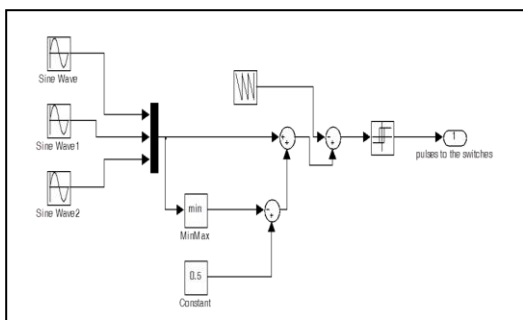

Fig. 15. Reduced switching carrier based space vector modulation based on common mode voltage addition and unique zero vector utilization

VI. CONCLUSION

This paper presents a review performance of carrier based distance vector PWM method to reduce harmonics and velocity control of induction motor. Carrier based SVPWM modulation provides simpler implementation with system and obtain useful torque with greater efficiency. With the advantage of low cost, require less computational efforts Carrier based

SVPWM becomes simple as compare to other methods. This paper introduced detailed overview of SPVWM, types and methodology which gives useful knowledge for the researcher to develop a new design of SVPWM for controlling speed of induction motor.

REFERENCES

- [1] Anjana Manuel and Jebin Francis, "Simulation of direct torque controlled induction motor drive by using space vector pulse width modulation for torque ripple reduction," *International Journal of Advanced Research in Electrical, Electronics and Instrumentation Engineering (IJAREEIE)*, 2013, pp. 4471-4478.
- [2] Sandeep N Panchal and Vishal S Sheth, "Simulation Analysis of SVPWM Inverter Fed Induction Motor Drives", *International Journal of Emerging Trends in Electrical and Electronics (IJETEE)*, Vol. 2, Issue. 4, April-2013.
- [3] K Sravanthi, M Ranjith and S Srinivasulu, "Space Vector Pulse Width Modulation Based Indirect Vector Control Of Induction Motor Drive", *International Journal of Innovative Research in Advanced Engineering (IJIRAE)*, ISSN: 2349-2163, Issue 1, Volume 2, January 2015.
- [4] Aasha Chauhan and Dr. Ravindra Pratap Singh, "a study paper based on space vector pulse width modulation technique for power quality improvement", *International Journal of Science Technology & Management*, Volume No.04, Special Issue No.01, February 2015.
- [5] H.Bain, Z. Zhao, S. Meng, J. Liu, and X. Sun, "Comparison of Three PWM Strategies-SPWM, SVPWM & OnecycleControl," *5th International Conference on Power Electronics Drive system*, vol. 2, pp. 1313-1316, 2003.
- [6] Padma Chaturvedi and Amarish Dubey, "Analysis of Space Vector Pulse Width Modulation VSI Induction Motor on various Conditions", *International Journal of Application or Innovation in Engineering & Management (IJAIEM)*, ISSN 2319 - 4847, Volume 2, Issue 12, December 2013.
- [7] D. Casadei, G. Serra and A. Tani, "Implementation of a direct torque control algorithm for induction motors based on discrete space vector modulation", *IEEE Transactions on Power Electronics*, vol.15, no.4, pp.769-777, 2000.
- [8] Siddheswar Kar Sarat and Kumar Mishra, "comparative study of sinusoidal pulse width modulated (spwm) & space vector pulse width modulated (svpwm) two-level voltage source inverter fed induction motor drives", *International Journal of Latest Trends in Engineering, Science and Technology*, ISSN: 2055-530X, Issue 6, Volume 1,