

SJIF Impact Factor : 7.001
ISI I.F Value : 1.241

ISSN:2455-7838 (Online)
DOI : 10.36713/epra2016



EPRA International Journal of
RESEARCH & DEVELOPMENT
(IJRD)

Monthly, Peer Reviewed (Refereed) & Indexed International Journal

Volume - 5 Issue - 11 November 2020



Chief Editor

Dr. A. Singaraj, M.A., M.Phil., Ph.D.

Managing Editor

Mrs.M.Josephin Immaculate Ruba

EDITORIAL ADVISORS

1. Prof. Dr.Said I.Shalaby, MD,Ph.D.
Professor & Vice President
Tropical Medicine,
Hepatology & Gastroenterology, NRC,
Academy of Scientific Research and Technology,
Cairo, Egypt.
2. Dr. Mussie T. Tessema,
Associate Professor,
Department of Business Administration,
Winona State University, MN,
United States of America,
3. Dr. Mengsteab Tesfayohannes,
Associate Professor,
Department of Management,
Sigmund Weis School of Business,
Susquehanna University,
Selinsgrove, PENN,
United States of America,
4. Dr. Ahmed Sebihi
Associate Professor
Islamic Culture and Social Sciences (ICSS),
Department of General Education (DGE),
Gulf Medical University (GMU),
UAE.
5. Dr. Anne Maduka,
Assistant Professor,
Department of Economics,
Anambra State University,
Igbariam Campus,
Nigeria.
6. Dr. D.K. Awasthi, M.Sc., Ph.D.
Associate Professor
Department of Chemistry,
Sri J.N.P.G. College,
Charbagh, Lucknow,
Uttar Pradesh. India
7. Dr. Tirtharaj Bhoi, M.A, Ph.D,
Assistant Professor,
School of Social Science,
University of Jammu,
Jammu, Jammu & Kashmir, India.
8. Dr. Pradeep Kumar Choudhury,
Assistant Professor,
Institute for Studies in Industrial Development,
An ICSSR Research Institute,
New Delhi- 110070, India.
9. Dr. Gyanendra Awasthi, M.Sc., Ph.D., NET
Associate Professor & HOD
Department of Biochemistry,
Dolphin (PG) Institute of Biomedical & Natural
Sciences,
Dehradun, Uttarakhand, India.
10. Dr. C. Satapathy,
Director,
Amity Humanity Foundation,
Amity Business School, Bhubaneswar,
Orissa, India.



ISSN (Online): 2455-7838

SJIF Impact Factor : 7.001

ISI I.F. Value : 1.241

DOI : 10.36713/epra2016

EPRA International Journal of Research & Development (IJRD)

Monthly Peer Reviewed & Indexed
International Online Journal

Volume: 5, Issue:11, November 2020

Indexed By:



Published By
EPRA Publishing

CC License





CONTENTS

S.NO	TITLE	AUTHOR/S	PAGES
1	FEATURES OF THE ADMINISTRATIVE-TERRITORIAL DEVELOPMENT IN BULGARIA https://doi.org/10.36713/epra5498	Assoc. Prof. Dr. Kamen Petrov	1-8
2	CONDITIONS FOR LEGAL PROTECTION OF INVENTIONS IN THE FIELD OF NANOTECHNOLOGY https://doi.org/10.36713/epra5142	Bakhtiyor Usubjonovich Akhmadjonov	9-12
3	THE EFFICIENCY OF UP TO DATE PEDAGOGICAL TECHNOLOGIES USAGE IN TEACHING ENGLISH	Akhmedova F.A.	13-15
4	SYNTACTICAL MEANS EXPRESSING THE EXPRESSIVITY IN A SCIENTIFIC TEXT	N. Ochilova	16-21
5	INFORMATION SEEKING BEHAVIOR ABOUT COVID-19 AND CONTAINMENT ZONES: A STUDY IN ODISHA	Dr. Yajnya Dutta Nayak, Mr. Aditya Prasad Sahoo, Dr. Manas Ranjan Mishra	22-27
6	MAIN DIRECTIONS OF IMPLEMENTATION OF THE STATE YOUTH POLICY IN THE REPUBLIC OF UZBEKISTAN	Jumayev Axmamat Shermamatovich	28-30
7	A STUDY ON CUSTOMER SATISFACTION TOWARDS ONLINE CAB BOOKING WITH SPECIAL REFERENCE TO COIMBATORE CITY	Dr. S. Suguna, M.Rohini	31-35
8	EFFECT OF PROCESSING ON PROXIMATE COMPOSITION OF JACKFRUIT (ARTOCARPUS HETEROPHYLLUS LAM.) SEED FLOUR	Sylvia Borgis, Pushpa Bharati	36-40
9	RELATIONSHIP BETWEEN EXCHANGE RATE AND SECURITIES' MARKET RETURNS: EVIDENCE FROM COMPANIES LISTED AT NAIROBI SECURITIES EXCHANGE	Tonui Hillary Kipkemoi, Dr. Isaac Naibei, Dr. Joseph Kiprono Kirui	41-48
10	A STUDY ON CONSUMER SATISFACTION TOWARDS AIRTEL WITH REFERENCE TO COIMBATORE CITY	Venkateshwara.V.S, Mr .A.David	49-54
11	A STUDY ON CUSTOMER SATISFACTION IN RED -MI MOBILE WITH SPECIAL REFERENCE IN COIMBATORE CITY	Mr. S.Muruganantham, Miss.Nandhini Senthilkumar	55-58
12	DESIGN AND ANALYSIS OF MULTILEGGED ROBOT FOR ENVIRONMENT MONITORING	Dr Jose Mathew, Lissen Sam, Lovin George Mathew, Merin T Edison, Pratibha Rachel John	59-70

13	A STUDY ON CUSTOMER PREFERENCE TO ROYAL ENFIELD WITH SPECIAL REFERENCE TO COIMBATORE CITY	Prasath.M, P.Dhanya	71-75
14	A STUDY ON CUSTOMER'S SATISFACTION TOWARDS LG PRODUCTS WITH SPECIAL REFERENCE TO COIMBATORE CITY	Dr. R. Mayilsamy, Harini.D	76-80
15	A STUDY ON INFLUENCE OF ADVERTISING ON BRAND AWARENESS AND CONSUMER'S PREFERENCE TOWARDS KALYAN JEWELLERS SHOWROOM (COIMBATORE)	Dr. D. Sivasakthi, Ananya.N	81-85
16	A STUDY ON A BRAND LOYALTY AND CONSUMER PREFERENCE TOWARDS APPLE IPHONE WITH SPECIAL REFERENCE TO COIMBATORE CITY	Nandhini.M, Dr. K.Vanaja	86-91
17	A STUDY ON CUSTOMER PREFERENCE TOWARDS HATSUN MILK PRODUCTS WITH SPECIAL REFERENCE TO COIMBATORE CITY	Dr. K. Vanaja, Reshma.A.L	92-96
18	A STUDY ON CUSTOMER SATISFACTION TOWARDS AMPERE ELECTRIC BIKE WITH SPECIAL REFERENCE TO COIMBATORE CITY	Dr. D. Sivasakthi, Geethanjali.P	97-101
19	STUDY ON CUSTOMER SATISFACTION TOWARDS ORGANIC PRODUCTS WITH REFERENCE TO TIRUPUR DISTRICT	Dr.S.Suguna, Nithya. V	102-105
20	A STUDY ON CUSTOMER'S PREFERENCE TOWARDS AMWAY PRODUCTS WITH SPECIAL REFERENCE TO COIMBATORE CITY	Mrs.P. Dhanya, Vishnupriya .B	106-110
21	INTEGRATION OF USER INTERFACE WITH FACIAL RECOGNITION SYSTEM https://doi.org/10.36713/epra5588	D.Manasa, N.Ramya Sri, Sk.Naveed, N.Ramya	111-115
22	FACE RECOGNITION FOR THE AUTOMATIC ATTENDANCE MANAGEMENT SYSTEM https://doi.org/10.36713/epra5583	N.Ramya Sri, D.Manasa, N.Ramya, Sk.Naveed	116-120
23	FORMULATION DEVELOPMENT OF BUCCAL FILM OF CARVEDILOL PHOSPHATE	Adiba Mulla, Rasika Mulik	121-127
24	DATABASE MANAGEMENT FOR FACIAL RECOGNITION SYSTEM https://doi.org/10.36713/epra5585	Sk. Naveed, N.Ramya, D.Manasa, N. Ramya Sri	128-131
25	TESTING OF MODULES FOR FACIAL RECOGNITION https://doi.org/10.36713/epra5586	N.Ramya, D.Manasa, N.Ramya Sri, Sk.Naveed	132-136
26	A STUDY ON FACTORS AFFECTING CUSTOMER'S INVESTMENT TOWARDS LIFE INSURANCE POLICIES OF LIC IN COIMBATORE CITY	Dr. S. Suguna, P. Ramya	137-140
27	TERRITORIAL SPECIALIZATION AND LOCATION OF AGRICULTURAL PRODUCTION - ADAPTATION TO MARKET RELATIONS	Muminov Bakhodir Orifjonovich, Bustonov Komiljon Kumakovich, Mardiev Nurali, Siddikov Zakhid Tulkunovich	141-145

	https://doi.org/10.36713/epra5620		
28	PHOTOSYNTHETIC PRODUCTIVITY OF CHERRY AND SWEET CHERRY LEAVES DUE TO ROOTSTOCK AND ARTIFICIAL FORMS OF TREE CROWNS IN THE GARDEN https://doi.org/10.36713/epra5623	Khalmirzaev Dilmurod Kamilovich, Yenileyev Najdat Shavkatovich, Abdikayumov Zaynilabiddin Abduvokhidovich	146-150
29	ASEAN'S CENTRALITY IN THE INDO-PACIFIC AND THE SOUTH CHINA SEA DISPUTE https://doi.org/10.36713/epra5633	Sushri Sangita Barik, Ayadoure S Stalin	151-153
30	A STUDY ON INVESTMENT PATTERN TOWARDS SALARIED EMPLOYEES IN COIMBATORE CITY	Mr. P. Kanagaraj, Pavithra. S	154-158
31	Mineral Composition and Antioxidant Profile of Jackfruit (<i>Artocarpus heterophyllus</i> Lam.) Seed Flour	Sylvia Borgis, Pushpa Bharati	159-162
32	A STUDY ON CONSUMER SATISFACTION TOWARDS GOOD DAY BISCUITS WITH SPECIAL REFERENCE TO COIMBATORE CITY	Mr. S. Muruganantham, Mrs. S. Menaka	163-166
33	THE CHANGING PERCEPTION OF MARKETING COMMUNICATION- TOOLS & PURPOSES: A DESCRIPTIVE STUDY	Dr. Sanjay Shrivastava	167-170
34	A STUDY ON CONSUMER SATISFACTION TOWARDS OPPO MOBILES WITH SPECIAL REFERENCE TO COIMBATORE CITY	Mr. A. David., Anish Kumar.K	171-175
35	A STUDY ON CUSTOMER SATISFACTION TOWARDS MOBILE PHONE IN COIMBATORE CITY	Mr. P. Kanagaraj, Shrinidhi. S	176-180
36	A STUDY ON MARKETING PROBLEMS FACED BY COCONUT PRODUCERS WITH SPECIAL REFERENCE TO SULUR TALUK	Dr. M. Kalimuthu, Dharani. S	181-186
37	A STUDY ON CUSTOMER'S SATISFACTION TOWARDS ONEPLUS MOBILES WITH SPECIAL REFERENCE TO COIMBATORE CITY	S. Muruganantham, Sangeetha. R	187-191
38	A STUDY ON FACTORS INFLUENCING USABILITY OF REFRIGERATOR WITH SPECIAL REFERENCE TO COIMBATORE DISTRICT	Dr. M. Kalimuthu, Monisha.A	192-196
39	A STUDY ON CUSTOMER SATISFACTION TOWARDS MRF TYRES (WITH SPECIAL REFERENCE TO COIMBATORE CITY)	Dr.S.Suguna, Saranya.B	197-202
40	A COMPARATIVE STUDY ON CONSUMER SATISFACTION TOWARDS FRESH FOODS AND PACKED FOODS WITH SPECIAL REFERENCE TO TIRUPUR CITY	Mr.P.Kanagaraj, P.Devika	203-207
41	A STUDY ON CUSTOMERS SATISFACTION TOWARDS HIMALAYA PRODUCTS WITH SPECIAL REFERENCE TO COIMBATORE CITY	Mr.P.Kanagaraj, M.Pavithra	208-212
42	FORMATION OF QUALITY INDICATORS OF COTTON LINES OBTAINED BY	Sh.A.Samanov, B.Kh.Amanov,	213-217

	INTERGENOMIC INTROGRESSIVE METHODS	D.U.Zakirov	
43	A STUDY ON IMPACT OF SOCIAL MEDIA MARKETING WITH SPECIAL REFERENCE TO FACEBOOK	Dr. S. Suguna, J. Nithin Arun Raj	218-223
44	FATS - FATS IN FOOD PRODUCTS AND THEIR PROPERTIES	Sulaymonova Gulchexra Xakimovna, Ashurova Muxabbat Zoirovna, Ganieva Nasiba Xikmatovna, Naubeev Temirbek Xasetullaevich	224-230
45	LOAN VOCABULARY OF THE TAJIK LANGUAGE IN SAMARKAND DIALECT	Abduvakhob Vakhidov	231-237
46	TRANSLATOR'S ACTIVITY AND KNOWLEDGE BASE IN LITERARY TRANSLATION https://doi.org/10.36713/epra5687	Khalilova Olima, Abdirakhimova Mokhigul	238-239
47	METHOD DEVELOPMENT AND VALIDATION BY RP- HPLC METHOD FOR CIOSTAZOL IN BULK AND TABLET DOSAGE FORM	Miss.Chavan A. S, Dr. Derle D. V, Dr. Gulecha V.S, Miss. Deore S. V.	240-245
48	TELOMERE BIOLOGY: TELOMERE STRUCTURE, FUNCTION AND RELATED DISEASES https://doi.org/10.36713/epra5707	Ranjan Kumar, Deepika Bhardwaj, Shikha Bharati, Manoj Kumar	246-254
49	AWARENESS AND PERCEPTIONS TOWARDS CROP INSURANCE SCHEME IN SPECIAL REFERENCE TO COIMBATORE DISTRICT	Dr. M. Kalimuthu, Mr. R. Sounder	255-259
50	A STUDY ON FINANCIAL PERFORMANCE ANALYSIS OF HINDUSTAN PETROLEUM CORPORATION LIMITED	Mr. Dr. M. Kalimuthu, Miss. Preeti Jaiswal. A	260-266
51	A STUDY ON CUSTOMER SATISFACTION TOWARDS SAMSUNG SMART PHONES WITH SPECIAL REFERENCE TO COIMBATORE	Dr. D.Sivasakathi, Banupriya .S	267-271
52	A STUDY ON CUSTOMER SATISFACTION TOWARDS GODREJ REFRIGERATOR WITH REFERENCE TO COIMBATORE CITY	Mr. S. Muruganantham, Ms. D. Janani Sri	272-274
53	A STUDY ON PASSENGERS PERCEPTION TOWARDS THE AIRLINE INDUSTRIES WITH SPECIAL REFERENCE TO COIMBATORE CITY	Mr.P.Kanagaraj, M. Sowmiya	275-279
54	THE PLACE OF LETTERS IN ABDULLA QODIRIY'S COMICS	Tursunova Faridahon Ganievna	280-282
55	IMPROVING THE MECHANISM OF PERSONNEL MANAGEMENT IN THE CONDITIONS OF THE DIGITAL ECONOMY	Yakubov Valijohn Ganievich, Shoev Davronbek Ahmadjonovich	283-286
56	LINGUOCULTUROLOGY AS A LINGUISTIC DISCIPLINE	Dadakhonova Zulaykho Ma'murjohn qizi, Ergasheva Malika Khakimjonovna, Usmonova Shakhnoza Yoqubjon qizi	287-289
57	METHODOLOGY OF TEACHING INTERACTIVE LEARNING MODELS AT THE FACULTY OF MILITARY	Mamadjanov Alisher Muradovich	290-292

	EDUCATION		
58	STUDY AND DESCRIPTION OF RUSSIAN AND UZBEK LINGUOCULTURES (CONTRASTIVE APPROACH)	Mamadjanova Gulmira Musinovna	293-296
59	A STUDY ON CUSTOMER'S SATISFACTION ON SOLAR ENERGY PRODUCTS WITH SPECIAL REFERENCE TO COIMBATORE CITY	Indrajith.P, Dr. K.Vanaja	297-301
60	A STUDY ON CUSTOMER SATISFACTION AND PREFERENCE TOWARDS ZOOM CAR	Dr. D. Sivasakthi, Sridhar. P	302-306
61	A STUDY ON CUSTOMER SATISFACTION ON ICICI BANK WITH SPECIAL REFERENCE TO COIMBATORE CITY	Mr.P.Kanagaraj, Hariharan .S	307-312
62	A STUDY ON WORK-LIFE BALANCE OF WOMEN IN HANDLOOM INDUSTRY (WITH REFERENCE TO PALLADAM TOWN)	Madhubala. T, Dr. K.Vanaja	313-318
63	SAVING HABIT AND INVESTMENT AWARENESS AMONG THE RURAL HOUSEHOLD WITH SPECIAL REFERENCE TO NANJUNDAPURAM PANCHAYAT	Dr.M. Kalimuthu, Manorabin.J	319-321
64	A STUDY ON CONSUMER BUYING BEHAVIOUR OF RETAIL TEXTILE SHOPS (WITH REFERENCE TO TIRUPPUR REGION)	Dishath Kumar. S, Mr. R. Mayilsamy	322-326
65	A STUDY ON FINANCIAL PERFORMANCE OF MAHINDRA AND MAHINDRA COMPANY	Mr. P. Kanagaraj, S. Loga Priya	327-333
66	GOOD PARENTING SYNERGY FOR THE CHILD'S CHARACTER DEVELOPMENT: THE ROLE OF WOMEN IN WOLE SOYINKA'S CHILDE INTENATIONALE	Ajayi, Christianah Olubunmi	334-343
67	CULTURAL GLOBALIZATION AND THE BAULS OF BENGAL	Dr. Susanta Mondal	344-349
68	DEVELOPMENT AND EVALUATION OF ANALGESIC PEDIATRIC FORMULATIONS- IBUPROFEN EFFERVESCENT GRANULES	K.Sandeep	350-354
69	A STUDY ON IMPACT OF CELEBRITY ADVERTISEMENTS IN SALES PROMOTION OF RELIANCE TRENDS WITH SPECIAL REFERENCE TO COIMBATORE CITY	Dr. M. Kalimuthu, Miss. Vidyasri. V	355-358
70	A STUDY ON CONSUMERS' SATISFACTION ON MCDONALD'S IN COIMBATORE CITY	Krithika. C, Dr. D. Sivasakthi	359-363
71	A STUDY ON CUSTOMERS' SATISFACTION TOWARDS WATER PURIFIER WITH SPECIAL REFERENCE TO COIMBATORE CITY	K. Sowmya, Dr. R. Mayilsamy	364-368
72	A STUDY ON IMPACT OF SOCIAL MEDIA ON CONSUMER BUYING BEHAVIOUR WITH SPECIAL REFERENCE TO COIMBATORE CITY	Mr. A. David, Padmapriya S	369-372

73	A STUDY ON CONSUMER'S BUYING BEHAVIOUR TOWARDS AROMA MILK WITH SPECIAL REFERENCE TO COIMBATORE CITY	Dr.D.Sivasakthi, C.Poorni	373-377
74	A STUDY ON CUSTOMER SATISFACTION TOWARDS RAYMOND CLOTHES WITH SPECIAL REFERENCE TO COIMBATORE CITY	Mrs. P. Dhanya, Ms. Niveda.K	378-381
75	A STUDY ON CUSTOMER SATISFACTION TOWARDS BISLERI DRINKING WATER WITH SPECIAL REFERENCE TO COIMBATORE CITY	Dr. S. Suguna, Mr. Thangaraj.V.S	382-385
76	A STUDY ON CUSTOMER SATISFACTION TOWARDS FASTRACK WATCHES WITH REFERENCE OF COIMBATORE CITY	Mrs. P.Dhanya, N. Naveen Kumar	386-390
77	AN IMPROVED DESIGN AND CONSTRUCTION WITH PERFORMANCE EVALUATION OF A MELON SEEDS SHELLER WITH A CONTINUOUS SEPARATOR https://doi.org/10.36713/epra5771	Adeleke M.B, Orelaja O.A	391-401
78	A STUDY ON CONSUMER PREFERENCE AND SATISFACTION TOWARDS DELL LAPTOPS IN COIMBATORE CITY	Dr.K. Vanaja, Anbarasu.U	402-407
79	SECURE DATA GROUP SHARING AND CONDITIONAL DISSEMINATION WITH MULTI-OWNER IN CLOUD COMPUTING https://doi.org/10.36713/epra5768	Sai Navya G	408-410
80	VOLATILE ORGANIC COMPOUNDS https://doi.org/10.36713/epra5763	Deepika Bhardwaj, Shikha Bharati, Ranjan Kumar, Manoj Kumar	411-423
81	A STUDY ON CUSTOMER PREFERENCE TOWARDS GOLD JEWELLERY WITH SPECIAL REFERENCE TO COIMBATORE CITY	M. Nambu Gayathiri, Dr. S. Suguna	424-428
82	A STUDY ON FINANCIAL PERFORMANCE OF CEMENT INDUSTRY WITH SPECIAL REFERENCE TO ACC LIMITED	V. Abinethra, Mrs. P. Dhanya	429-439
83	A STUDY ON BRAND LOYALTY OF CUSTOMER TO SELECT THE MILK BRAND WITH SPECIAL REFERENCE TO COIMBATORE CITY	Loksanjit.P.K, Dr. K. Vanaja	440-445
84	A STUDY OF WORK PLACE ENVIRONMENTAL PARAMETERS AND OCCASIONAL HEALTH PROBLEMS AMONG WOMEN CONSTRUCTION WORKERS IN COIMBATORE	Hariharan. B, Dr. M. Kalimuthu,	446-451
85	ACID FLY ATTACK AMONG THE RESIDENTIAL STUDENTS IN RURAL AREA AT SOUTH OF TAMILNADU	Ms.E.Kalasri, Mr.K.Jayaprakash, Dr.A.Rajathi	452-455
86	A STUDY ON FINANCIAL PERFORMANCE OF MARUTI SUZUKI MOTORS	V. Gokulapriya, Mrs. P. Dhanya	456-463
87	A STUDY ON CUSTOMER SATISFACTION TOWARDS FLIPKART	Mr.A.David, T.P.Prabin	464-468

	SERVICES		
88	THE EFFECT OF CLIMATE CONDITIONS IN UZBEKISTAN ON BIOLOGICAL INDICATORS OF CHINESE SILKWORM BREEDS AND HYBRIDS https://doi.org/10.36713/epra5764	Oripov Otabek Oripovich, Umarov Shavkat Ramazanovich	469-475
89	A STUDY ON CUSTOMER SATISFACTION OF WHIRLPOOL HOME APPLIANCES	Dr. M. Kalimuthu, Ms. Sandhiya. D	476-480
90	A STUDY ON CONSUMER SATISFACTION TOWARDS DATSUN CARS WITH SPECIAL REFERENCE TO COIMBATORE CITY	P.Dhanya, M.Saravanan	481-486
91	A STUDY ON CONSUMER SATISFACTION TOWARDS FEMALE BEAUTY CREAMS IN HIMALAYA PRODUCTS (WITH SPECIAL REFERENCE TO COIMBATORE CITY)	Dr. M. Kalimuthu, M. Keerthana	487-491
92	STUDY ABOUT BIOFUEL PRODUCTION FROM FISH WASTE AND ITS POTENTIAL IN KERALA	Soorya Narayan	492-496
93	A STUDY ON CUSTOMER'S SATISFACTION TOWARDS AAVIN MILK WITH SPECIAL REFERENCE TO TIRUPUR CITY	B. Arun Nithish, Mrs. P. Dhanya	497-501
94	A STUDY ON CONSUMER SATISFACTION TOWARDS BANKING SERVICE PROVIDED BY SBI WITH SPECIAL REFERENCE TO ANNUR BRANCH	Ranjitha. C, Dr. D. Sivasakthi	502-505
95	A STUDY OF FACTORS AFFECTING IMPULSE BUYING BEHAVIOURS AND SPECIAL REFERENCES OF PAZHAMUDIR NILAYAM IN COIMBATORE	Ms. M. Kowsalya, Dr.K. Vanaja	506-508
96	A STUDY ON CUSTOMERS' AWARENESS, PREFERENCES AND SATISFACTION TOWARDS AJIO ONLINE SHOPPING APP IN COIMBATORE CITY	Mr. R. Mayilsamy, Ms.M.Kungumadevi	509-512
97	A STUDY ON CUSTOMER'S PREFERENCE AND SATISFACTION TOWARDS ORGANIC EDIBLE OIL WITH SPECIAL REFERENCE TO COIMBATORE CITY	Mr.R.Mayilsamy	513-517
98	A STUDY ON CUSTOMERS' PERCEPTION TOWARDS DIGITAL PAYMENT SYSTEM WITH SPECIAL REFERENCE TO TIRUPPUR CITY	Dr. R. Mayilsamy, Mr. Gokula Krishnan. D	518-521
99	CONFLICTS IN THE TURKESTAN SYSTEM OF GOVERNMENT (1917)	Abdullaev Zafar	522-524
100	COMPARISON OF THE GRAMMATICAL CATEGORY OF GENDER IN RUSSIAN AND GERMAN	Soliev Rakhimjon Ibrokhimovich, Mamasoliev Rustamjon Adxamjonovich, Abdurazzakov Yusufjon Usmoilovich	525-527
101	MORAL HERITAGE AS AN INTEGRAL PART OF SPIRITUAL HERITAGE	Normatova Dildor	528-531

102	ARTISTIC AESTHETIC FUNCTION OF LETTERS IN THE NOVEL "PAST DAYS"	Xasanova Xikmatoy	532-534
103	INFLUENCE OF GEOIDEOLOGICAL PROCESSES ON INTERETHNIC RELATIONS	Olimova Mohinur Ravshanbek qizi, Jamalova Nargiza Ulugbek qizi	535-536
104	MIGRATION FACTORS OF A WORK OF ART	Nishanov Yashin	537-538
105	FACTORS FOR THE DEVELOPMENT OF INTERCULTURAL COMPETENCIES OF FUTURE TEACHERS	Mahamajonova M.M	539-542
106	VISUAL AIDS AND TECHNICAL AIDS IN TEACHING ENGINEERING GRAPHICS	Mambetov Rashid Mirzalievich, Tanjariva Rano Akramovna	543-545
107	THE MAIN FEATURES OF PEDAGOGY IN THE FIELD OF ART	Akhmedov Tulkin Baltaboevich, Umirzakov Rakhmatilla Rakhmonberdievich	546-547
108	SIMULATION OF CODING METHODS BASED ON TWO-DIMENSIONAL PREDICTION AND TWO-WAY ERROR SIGNAL LIMITATION	R.Usmanov, E.D.Imomnazarov	548-552
109	THE IMPORTANCE OF EDUCATIONAL INNOVATION, MORAL AND SPIRITUAL EDUCATION IN THE DEVELOPMENT OF CIVIL SOCIETY	Kholmatov Shahobiddin	553-556
110	THE ROLE OF THE ISLAMIC TEACHINGS OF MOTURIDIA	Qambarov Abdumutal Akhadjonovich, Karimov Ulmasbek Umaralievich	557-559
111	LANGUAGE ANALYSIS OF LEXEMAS EXPRESSING FOLK CRAFTS	Jurayeva Nargiza Jamoliddinovna	560-562
112	COMPETENT APPROACH IN TEACHING PROBABILITY THEORY AND MATHEMATICAL STATISTICS	Toshboeva Saida Raxmonberdiyevna	563-567
113	THE DIGITALIZATION OF EDUCATION IN THE CONTEXT OF A NEW TECHNOLOGICAL GENERATION	Nurmatova Maftuna Ilkhamova	568-570
114	INHERITANCE AS A UNIVERSAL LAW OF DEVELOPMENT	Mamatov Obidkhon Vakkosovich	571-574
115	ON THE IMPORTANCE ABOUT CULTURE IN LEARNING FOREIGN LANGUAGES	M.Habibullaev	575-578
116	THE ROLE OF MUSIC AND MUSIC EDUCATION IN THE SPIRITUAL AND MORAL EDUCATION OF YOUTH	Qahramon Bobokulov	579-580
117	EXPRESSION OF SOCIAL NORMS IN THE WORK OF JADID THINKERS	Berdikulova Surayyo Aslamovna	581-582
118	USE OF PERCEPTION MAP IN NATIVE LANGUAGE LESSONS	Ergasheva Muhayyo Valijonovn	583-586
119	NOVERBAL MEANS EXPRESSING THE VERBAL PERSONALITY	Hojaliev Ismoil Tojibaevich	587-589
120	INTERPRETATION OF NATIONAL CHARACTERS IN THE NOVEL "UTGAN KUNLAR" BY ABDULLA QADIRI	Sabirdinov Akbar Gafurovich	590-592
121	NUTRIENT INFLUENCE IN SOIL ENVIRONMENTS IN COTTON	Nazarov Mamadali, Akhmedova Dilfuza, Yunusov Mirzakarim	593-596

122	THE HISTORY OF THE STUDY OF FOLLOW-UP SENTENCES IN COMPOUND SENTENCES	Teshaboev Dilmurod Rahmadjonovich	597-599
123	THE PROCESSES OF DEVELOPMENT AND MOTIVATION OF PROFESSIONAL COMPETENCE OF FUTURE PEDAGOGICAL EDUCATORS ON THE BASIS OF REFLEXIVE MONITORING	Hamraeva Aziza Farhadovna	600-602
124	A STUDY ON CUSTOMER'S SATISFACTION TOWARDS MAHINDRA BOLERO IN COIMBATORE	Dr. P.Dhanya, M .Kousalya	603-606
125	PRIORITY ANALYSIS OF ROAD DEVELOPMENT IN REGIONAL DEVELOPMENT IN SOUTH LABUHANBATU REGENCY	Toni Zevselvey Silalahi, Rahim Matondang, Agus Purwoko	607-613
126	ANALYSIS OF GREEN OPEN SPACE DEVELOPMENT, TEBING TINGGI KOTA SUB-DISTRICT, TEBING TINGGI CITY	Meilina Daulay, Agus Purwoko, Sirojuzilam	614-621
127	A STUDY ON CUSTOMER SATISFACTION TOWARDS THE HINDU NEWSPAPER (COIMBATORE CITY)	Mr. A David, Mr. M.Veeramani	622-627
128	A STUDY ON CUSTOMER SATISFACTION TOWARDS UBER CAB SERVICES IN COIMBATORE CITY	Dr. R. Mayilsamy, Karthic. R.S	628-632
129	A STUDY ON COMPARATIVE LEVEL OF SATISFACTION BETWEEN GOVERNMENT BUS PASSENGER AND PRIVATE BUS PASSENGER IN COIMBATORE	Mrs. N. Ramya, Guru Prasath. M.V	633-637
130	A STUDY ON CUSTOMER SATISFACTION TOWARDS TITAN WATCHES WITH SPECIAL REFERENCE TO COIMBATORE CITY	Dr. S. Suguna, Gnana Sekar. A	638-641
131	A STUDY ON PASSENGERS SATISFACTION TOWARDS SOUTHERN RAILWAY SERVICES WITH SPECIAL REFERENCE TO COIMBATORE JUNCTION	Dr. N. Ramya, Madhanraj. K	642-646
132	A STUDY ON CONSUMERS' SATISFACTION TOWARDS AMAZON ONLINE SHOPPING WITH SPECIAL REFERENCE TO COIMBATORE CITY	Anusuya.A, Dr. R. Mayilsamy	647-651
133	A STUDY ON CUSTOMER SATISFACTION TOWARDS RAPIDO BIKE TAXI SERVICES	Mr. A David, Mr. M.Pyntamil	652-658
134	A STUDY ON INCOME GENERATION POTENTIAL OF WOMEN SELF-HELP GROUP WITH SPECIAL REFERENCE TO TIRUPUR	Dr. Vanaja, Ms. Pavithra.S	659-662
135	WAYS OF IMPROVING EFFECTIVENESS IN TEACHING FOREIGN LANGUAGES: AUDIO-LINGUAL APPROACH IN ENGLISH LANGUAGE	Jumayev Sanjar Jurakulovich	663-665



FEATURES OF THE ADMINISTRATIVE-TERRITORIAL DEVELOPMENT IN BULGARIA

Assoc. Prof. Dr. Kamen Petrov

*Vice Dean in Faculty Management and Administration, Department Regional Development
University of National and World Economy, Sofia, Bulgaria*

Article DOI: <https://doi.org/10.36713/epra5498>

ABSTRACT

Knowledge of socio-economic processes for the realization of the state will determine the course and their division of the territory of the administrative-territorial and territorial units. Planning and construction of each administrative unit must meet the structural limits, requirements, parameters and characteristics peculiar to themselves socio-economic processes. Territorial unity and socio-economic development is implemented in line between the territorial scope of ATU, on the one hand, and the boundaries of socio-economic impact of public policies in the territories of another. It ranks among the administrative territorial unit active and important elements of the development of public relations.

KEY WORDS: *territory, state, structure, administration, development*

INTRODUCTION

In the modern nation-state, the administrative-territorial structure is a key element of the organization of the state and public administration. Bulgaria is located in Southeast Europe and has a

predominant local self-government. The region is an administrative territorial unit for conducting regional policy, implementing public administration at the local level and ensuring the concurrence of national and local interests.

Figure 1. Geographical position of Bulgaria



Source: Bulgarian Academy of Sciences, Geographical Institute

The territorial structure to a large extent determines the significance of all ongoing life

processes in the state organism. It includes the division of the territory into administrative-territorial



(ATE) and territorial units and (TE), determination of their hierarchy and subordination, so as to create conditions for targeted state influence through policies, imposition of standards and provision of services. Settlements and settlement formations are defined as territorial units (TE). The settlements are divided into towns and villages, indicating the order and conditions for their transformation.

The settlement formations are divided into national and local, indicating the order of their determination. A unified approach and general principles are applied in determining the main elements of ATE and TE - territory, borders, name, administrative center, population. The population takes part in the processes of administrative-territorial changes (ATP), applying forms of direct democracy. Alternative possibilities for the implementation of specific types of territorial changes are allowed. In

this sense, the purpose of this article is to show the chronology of administrative-territorial changes in recent years and how they affect the regional development of the national territory. Moreover, in the Bulgarian state tradition the municipality is the main administrative-territorial unit in which the local self-government in the Republic of Bulgaria is carried out. For example, only in the last 40-50 years in the country reforms have been carried out in the municipalities and until 1979 there were 1389 municipalities. After the large-scale administrative-territorial reform carried out in the period 1978-1979, the number of municipalities was reduced to 291. After the change, mainly affecting the municipalities, the dynamics of changes decreased significantly in the next reform (1989-1999), related to the introduction of 28 districts, the number of municipalities is 265.

Figure 2. Image of the municipalities in Bulgaria (265 municipalities)



Sources: MRRB, NSI

With the adopted Law on Administrative and Territorial Organization of the Republic of Bulgaria (SATURB), the new foundation was built, but at the same time the debate was opened to fill the gaps and gaps in it, so changes and assessment of the administrative structure become necessary. The territorial and settlement structure is an activity of legal, economic and social subjects determined by the laws of the country, whose activity aims at creating favorable conditions for living, work and recreation of the population. The need for urban development stems from the need to create a living environment and improvement of settlements so as to create favorable conditions for human development. Settlements as a basis for concentrating public activity are formed during the historical development of society. Influenced by the positive development of society and the development of productive forces. The settlements are created before the state and on their basis the state formations are created. In the beginning, villages and towns were considered as

settlements. Subsequently, settlements and settlements are spoken of where there is active human activity, as a result of which the natural environment changes. This is also reflected in the Bulgarian legislation. For settlements and settlements are recognized holiday villages, resorts and industrial complexes, which have different factors and legal status. The factors that affect the settlement structure are in several categories. They are economic, political, geographical and social, type, structure and character of the population, as well as its distribution.

1. Characteristics of the next administrative-territorial structure in the country

The influence on the settlement structure shows various natural geographical factors such as relief, fuels, energy sources, forest resources, territories. In terms of relief, Bulgaria ranks among the countries with the most favorable conditions for rural development. It has a relatively equal position on the territory. Low lands are 31%, hilly - 28%. The



average altitude is the most favorable for construction and public works, namely 470 m. Water resources are unevenly distributed. At present, in the current Administrative-Territorial Organization (ATU) of the Republic of Bulgaria it can be characterized as stable. Unlike a number of countries in Europe, there is no process of fragmentation in Bulgarian municipalities. There are two types of administrative and territorial units - districts and municipalities, in accordance with the constitutional provisions [1]. The changes in the socio-economic relations of the country are protected by the constitutional protection of ATU. All constitutions adopted in the Third Bulgarian State determine the normative framework of the administrative-territorial organization of the country. On the other hand, the formed mayoralties from one or several settlements as independent administrative and territorial units (CATE) in the municipalities allow in Bulgaria to impose specific regulation and development of the local self-government and the administration of the population. With the increase of the population, districts have been formed in the Sofia Municipality and the two big cities over 300 thousand people, another issue is that depending on the administrative burden I consider it appropriate for the municipalities with a population of more than 125 thousand people to be able to form districts as administrative units. in them. The structure of the territory is a system of measures, acts and actions of factual legal nature, which aim to create regulatory conditions for the use of the earth's surface for work, recreation and rehabilitation of the population. The territories in the country are divided into groups according to different criteria. Through this division, the state determines which parts of its territory can be used for what purposes, regardless of their physical and geographical location. Until now, according to the law on territorial and settlement organization, there was one main division. It depended on the purpose of the territory [2].

Refers to urban and rural areas. It seeks to eliminate the delineation of urban and non-urban areas and to create a unified regime that depends only on the specifics of the territory and its purpose according to the adopted plans. There are several features of the legal characteristics of the structure of the territory. In the first place, all activities on the structure of the territory are subject to legal regulation. The Spatial Planning Act defines the territorial and land properties according to their main purpose. It is determined specifically by development schemes and development plans. Land properties are parts of the territory and their use depends on the nature and on the projections and prospects of the respective plans [3].

The first, main category is the so-called urban areas. They are used to meet the immediate needs of people related to work, leisure and recovery. The second next category are agricultural categories

(territories). They cover arable land and often uncultivated land. The third category is forest areas. The fourth - protected areas. A territory acquires the character of protected in connection with its specific natural, historical, climatic or cultural features. The legislation allows for a change in the purpose of the territory. For this it is necessary to perform certain actions. In the first place it is important whether the construction event is planned for the respective territory or land property. This means that under this law only construction can be a reason for a change in the purpose of the territory. Another important condition is to have a detailed development plan in place. This means that this plan has been drawn up by the relevant competent authorities and the time limits for appeal have expired or have not been appealed. For the territories or parts of them, which for public, state and public property, it is not allowed to change the purpose. An exception can be made in the first place if there is a permit from the regional governor for state public property or from a general. Council for public common. Property. the structure of the territories and the specific purpose of each part of these territories depends on the provisions, which are normatively established by a development scheme and development plans. Within the territories there are separate plots of land. On the site of a plot there is talk of land. Legislation related to the structure of the territory gives a legal definition of this concept. This is the part of the territory that is defined by boundaries with the right of ownership and can be used in accordance with the norms contained in the plans. The land properties themselves can be grouped. This is done in territorial and development zones, which are determined in accordance with the general urban plans. Construction is allowed only after a detailed development plan has been approved and entered into force. The legislation is a legal definition of construction as a legal normative activity of the various legal entities. According to the law on spatial planning, construction is the location and view of buildings, structures, networks and facilities in land properties. Construction in separate territories is allowed under conditional procedures. It may be laid down in a detailed development plan or in several special laws.

In the modern world there are more than 190 state entities, and depending on their characteristics and structure, they determine the respective competencies of government and regulate the relationship between the state and citizens. In this regard, public administration is regulated by the basic laws of the countries or in other words by the Constitution of Bulgaria. Accordingly, the requirements for the development of the territories are determined by development schemes and plans in accordance with the current regulations. In the separate states according to the separate constitutions



the level and character of the legal regulation of administrative-territorial structure is determined.

In most countries, the regulation of the administrative-territorial structure is at the constitutional, legal and by-law level. Territories with special territorial protection, including territories with specific characteristics, determined by the order of separate laws, may acquire a special regime of structure and control. The scope and mode of their device are determined by development schemes and plans. The territorial structure analyzes the current state of the settlement network, the problems and trends of the urban environment. The ratio between urban and rural population, territorial scope of urbanized and non-urbanized territories, depopulated settlements, unusable buildings, environmental problems related to urbanization, expansion of urban areas at the expense of agricultural land. Municipal and settlement network, number and type of settlements, density, density (altitude / 100 sq. Km.), Infrastructure provision.

The visualization (depiction) of the territorial structure in the separate territory reflects - the agricultural territories, the forest fund, the urbanized, protected and disturbed territories. Assessment of their condition and ratio, opportunities for development and improvement of this structure [4].

The comparative data for the Bulgarian municipalities by population and territory in the European context show that they are comparable with the medium-sized European municipalities. The quantitative characteristics for population and territory of the districts in Bulgaria refer them to the group of NUTS 3 units according to the European statistical categorization.

With a total territory of 111,001.9 km² and a population of 7,336,710 people (March 30, 2012), the main parameters of the two types of administrative units (excluding the Sofia Municipality) for the districts: by population - an average of 240,264 people (out of 117,809 up to 707 570), by territory - an average of 4061.2 km² (from 2023.0 to 7748.1). On average, about 10 municipalities (from 4 to 22) are included within one district. For the municipalities (excluding Sofia): by population - an average of 24,666 people (from 1,188 to 34,173), by territory - an average of 416.9 km² (from 44.4 to 1,366.6). An average of 20 settlements are included in one municipality. In the social and economic development of the country an important feature in the grouping of districts and municipalities is the criterion population. According to the existing administrative units and their grouping of the districts by population, it brings to the fore the group of districts with a population of up to 200 thousand people. It covers 14 districts, followed by the group of districts with a population of 200 to 400 thousand people, which includes 11 districts. The grouping of municipalities by population distinguishes two groups

of municipalities - the first includes municipalities up to 10 thousand people, and the second - from 10 to 30 thousand people. The first group covers 103 municipalities (39% of all municipalities in the country). About 8.1% of the country's population live within this group of municipalities and these municipalities include 25% of the total territory of the country. The second group covers 112 municipalities (42% of the total number). The municipalities of this group inhabit 25.4% of the population, the territory of the municipalities included in it represents 46% of the territory of the country. The current 28 districts have been operational since the beginning of 1999 [7]. In practice, they reproduce the number and boundaries of the districts that existed until 1987. This change took place mainly under the pressure of society, as the nine districts created in 1987 could not control and effectively and efficiently exercise the powers assigned to them. Created with the means of the command-administrative approach, they were very different in terms of territory and population, as well as in terms of economic potential. During the period of their existence, they could not readjust the system of communications and relations with the former districts, to overcome the acute shortage of human resources, to control the processes of disintegration and restructuring of economic structures, to exercise effective control over the work of municipal self-government bodies. . The automatic reproduction of the county model, created in 1961, also has its pros and cons [3].

2. Administrative territorial changes and reforms in the municipalities of Bulgaria

During the analyzed period the administrative and territorial structure of the country was enriched with nine new administrative-territorial units - municipalities. All newly created municipalities (Primorsko, Dolna Banya, Gurkovo, Nikolaevo, Krichim, Perushtitsa, Stamboliyski, Kuklen and Sopot) are of the type "creation through separation". Seven of the changes were implemented in the period July 1997 - April 1998, the last change being the establishment of the municipality of Sopot in 2003. As in 2014, the case of Sarnitsa. The reason for the requested separation is the distance of 40 km to Velingrad. territorial change within the boundaries of the municipality of Velingrad and for the creation of a new municipality with an administrative center in the town of Sarnitsa. It will include 2 more villages - Medeni Polyani and Pobit Kamak.

In the last 20 years after the adoption of the laws on territorial and administrative structure, changes have taken place with events "creation by merger", "creation by division", "creation by new administrative-territorial structure". There are four "donor" municipalities of new municipalities (Samokov, Maglizh, Rodopi and Karlovo) and most new municipalities (44.4%) were created on the basis of separation from Rodopi municipality - Perushtitsa,



Krichim, Stamboliyski and Kuklen. The municipalities of Gurkovo, Sopot and Nikolaevo are separated from the municipality of Maglizh and formed. The last established municipality of Sarnitsa was separated from the municipality of Velingrad in 2014. Within the analyzed period, twenty-four changes in the closure of municipalities were registered. However, all the changes are related to the introduction of the regions as constituent administrative-territorial units (SATU) in the city of Sofia and the closure of the existing 24 Sofia

municipalities. . In the national register of settlements there are no common events with "closure upon merger", "closure upon division", "closure upon accession" and "flood". If we assume that the municipality as the main unit of local self-government in Bulgaria is the bearer of the legal and organizational opportunities for citizen participation in government, so that a conclusion can be drawn that changes during this period leads to the development of local democracy and more. wide distribution of citizens in government [7].

Figure 3. Location of the municipalities in Bulgaria by development

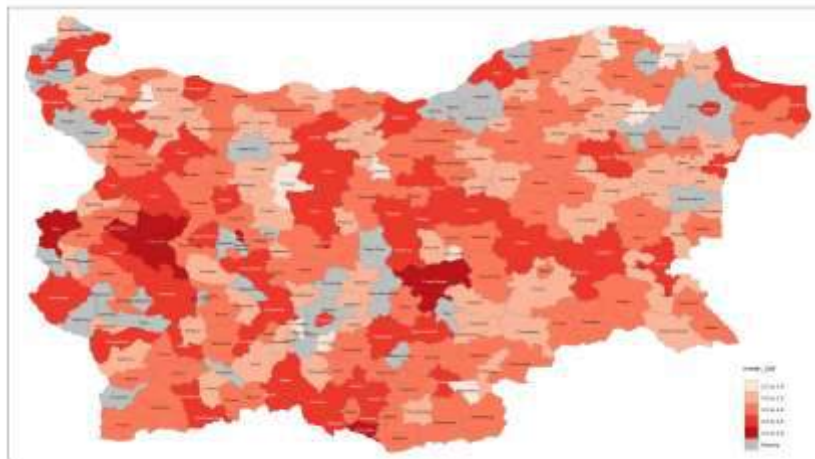

Source: NSI, MRRB

Analyzing the intensity and dynamics of the changes made at the municipal level in the period after the adoption of the law on territorial and settlement planning and especially after its amendment in 1998 (amended, SG No. 154/1998), it can be concluded that there is a relatively modern legislation, covering to a large extent the social processes in the field of territorial organization of the country. At the same time, it should be noted that the existing legislation does not address development processes, which is particularly important in a highly dynamic socio-economic environment, in particular demographic and urban change over the last ten years. Although slowed down, the tendency to increase the number of administrative units is one-way and reflects the irrationality of individual subjective decisions and some disparities in the territorial organization of the country in recent decades. Creation or closure of municipalities due to "merger", "division", "accession" and "deletion" are forms that are not used in practice to carry out administrative-territorial change at the municipal level. The use of some of these forms in the future should be encouraged by ensuring economic interest, using the tools available to the central government (eg relations with the national budget, access to resources from the Structural Funds, etc.). During the analyzed period there is no case of closure of a municipality. The comparative data for the Bulgarian municipalities by population and territory in the

European context show that they are comparable with the medium-sized European municipalities, which is considered as a favorable factor for their successful development and functioning. Therefore, improving the efficiency of territorial governance must be at the expense of the qualitative development of the decentralization process in the country, without questioning the established model as a whole. However, in a number of municipalities (especially individual municipalities, which currently do not meet the conditions for independent existence), there are negative trends in their condition, such as severely deteriorating demographic characteristics and processes, limited and constantly decreasing resource potential (including human and financial), weak economic development and low tax base. These are obstacles that severely limit their future development and raise questions related to taking measures to increase the efficiency of their existence. There is a tendency to attract the peripheral settlements from the composition of small and relatively less developed municipalities to larger municipalities. This is very pronounced in cases where the host municipality is also a regional center. It is necessary to make a careful analysis of the size of the administrative-territorial and territorial units in terms of efficiency, effectiveness of the services provided and the quality of local democracy, as well as the impact of possible change. In our country, in relation to the municipalities, the districts can do it,



and in the case of the mayoralties and the settlements - the municipalities. For example, when a unit is judged to be too small in some respects, it is necessary to exhaust the possibilities of association and cooperation - horizontally, vertically and cross-border to improve its performance. At the same time, when a unit is considered large in some respects, it is necessary to exhaust the possibilities for internal deconcentration and decentralization. On the other hand, administrative-territorial changes in geographical boundaries should be based on accurate research and assessments and in accordance with the opinion of the population [5].

3. Guidelines for improving the administrative and territorial organization in Bulgaria

Changes in the administrative and territorial structure are an important component of the environment, so the changes must have the necessary quality and focus. For example, there are several municipalities (Rhodopes, Maritsa, Tundzha and Dobrich), whose names do not meet the requirements of Article 7 (3) of the SASA - "The name of the municipality is the name of the settlement - its administrative center." Understanding that this is the smallest problem related to their functioning, the correctness presupposes a change in the SASBM, which allows for exceptions to this rule, unless action is taken related to their reorganization. Establishment or closure of municipalities due to "merger", "division", "accession" and "deletion" are forms that are not used in practice to carry out administrative-territorial changes (ATP) at the municipal level. The use of some of these forms in the future should be encouraged by ensuring economic interest, using the tools available to the central government (eg relations with the national budget, access to resources from the Structural Funds, etc.). Significant changes and concretization of the conditions for the establishment of municipalities and respectively for the implementation of changes with them will contribute to this. To determine the order and manner of proving the observance of the requirement of art. 8 (1) item 5 for necessity of sufficient financial capacity for financing the expenses of the newly created municipality as well as to discuss the possibility for introduction of other conditions for the economic and financial potential of the created unit [6]. It is necessary to overcome the existing inequality of large settlements in connection with the possibility of creating areas in them - for those with a population over 300,000 people by law, and for those with a population over 100,000 - by decision of the municipal council. The organization on the territory of large cities is a matter of local importance and this implies full powers in this area of the municipal council. This would lead to the repeal of the Law on the Territorial Division of the Sofia Municipality and Large Cities and a change in the texts of the Spatial

Planning Act, as well as to increase its democracy and the possibility of decentralization of powers to municipal councils. Article 30 states that the change for the closure of town halls / districts is carried out in the order of their establishment, which means that a referendum must be held. With regard to the districts in the capital and the big cities, this provision creates difficulties, as it presupposes that an amendment to a law be requested for any change. According to the current provision, it also turns out that all closures of town halls have been carried out illegally so far, because in none of the cases a consultation of the people has been conducted, as the reason for the closure is legal - a change in the required population. town hall. This implies a complete rethinking of the texts related to the closure of the Independent Administrative and Territorial Units (SDUs). It would be possible for the closure of these units in case of non-fulfillment of the conditions for their establishment, when the population has no interest in such action and would not support a subscription or referendum, to be carried out administratively for a certain period of time. Related to the issue of closing down existing administrative units is the issue of creating them. Their main purpose is to provide better services to the population by decentralizing administration and services. On this basis, their creation should be within the exclusive competence of the municipal councils and / or the regional governor, and a consultation of the population should be carried out, but with the help of simpler forms of referendum and subscription. It is possible to envisage 6 months before the local elections on the proposal of the Municipal Councils the regional governor to issue an order to determine the mayoralties on the territory of the district for the next term. This will also imply the closure of those who do not meet the requirements of the law. It will be of practical use to specify the parameters for proving the possibility of performing functions provided by the municipality - a second condition for the establishment of a mayor's office. In order to promote the structuring of the territory of the municipalities and the creation of viable mayoralties with opportunities for providing access to the population. This means a greater volume of public services and ensuring operational autonomy through delegated budgets, the number of people to create town halls should be increased. The need to expand the conditions for the establishment of administrative units could be assessed with the introduction of a condition for road transport distance of the settlements to the mayor's office, financial efficiency, etc. following the logic of the provisions for the establishment of a municipality. Both units have a common goal - to provide public services at the lowest possible price in terms of local government [6].



In order to avoid preconditions for subjectivism and improvement of the legal framework, it is recommended to specify the conditions for creation of a new settlement. The closure of settlements is a problem because by law this is done in the order of creating grounds for a request by the population or by the mayor of the municipality. Mayors usually have no interest in closing settlements, and when they are depopulated or have no land or construction boundaries, there is no one to initiate the request by subscription. The possibility of closing the settlements administratively in the absence of a population with a permanent address should be discussed. Although declared unconstitutional in 1996, to rehabilitate the possibility of citizens' initiative to change the name of the settlement or, if the initiative is of an administrative structure (mayor's office, municipality, district, central government), to conduct a consultation with the local population. This presupposes the administration of the President of the Republic of Bulgaria, in whose powers is the name of the settlements to propose conditions and order for their change. There are no practices to confirm the existence of certain benefits for declaring a settlement a city (except for the norms for construction under the Spatial Development Act). The expediency of the change (especially the declaration of the resort settlements as a city) is relatively debatable, as the formal motives for it are related to the improvement of the development of the settlements, but this is the goal of each local administration, respectively each settlement, and the declaration of settlement. a place for a city would not help this process. Moreover, the vague benefits and subjective informal goals pursued in making this change largely predetermine the absence of a clearly defined effect. It is also appropriate to discuss who the decision-making body should be *на село за град*. Should this be within the competence of the Council of Ministers (CoM) or can this function be taken over by the Minister of Regional Development and Public Works, the regional governor or the municipal council. The settlement entity is present in the legislation without defining the specific benefits of its existence, and against the background of the other administrative units and territorial ones it is unconvincing. He questions of whether the place of this unit is in this law or in the Spatial Planning Act is debatable. By their nature, these are not territorial units because they are located in the territory of other urbanized territories such as settlements. It is right that the law on the settlement structure should regulate only the possibility for the settlement education to grow into a settlement when there is a permanent settlement of the population in it.

CONCLUSION

The administrative-territorial structure of our country had to be modern and effective, to give new content and develop local democracy, to strengthen the processes of decentralization, to ensure the formation of viable territorial communities and local authorities with strong powers and responsibilities. In the law on territorial organization as basic structural units on the territory of the country are again defined the municipalities and the districts and as constituent administrative-territorial units - the mayoralties and the regions. All administrative-territorial units are characterized by territory, borders, population and name. With the adoption of the legislation concerning the territorial organization came into force an extremely important legal framework containing formulated conditions and criteria for the formation of units subject to the law and relevant procedures, which made it a necessary regulator of the process of administrative-territorial organization. It contributed to the creation of administrative-territorial units working as close as possible to the population and made the process of functioning of local self-government more efficient. In the conditions of real membership of Bulgaria in the European Union it is necessary to build the meso-level of government in the country. Thus, to transfer in practice the transfer of powers from the central to the regional administration, which will improve both the vitality of the regions and their centrifugal forces related to the effective management and development of the territories. During the period of work on the implementation of the administrative-territorial reform in the country, many other issues arose, some of which have not yet found their concrete and correct solution. In this direction we must strive to continue the process of improving the functional and institutional organization of local authorities and increasing the fiscal burden of municipalities in the state development of Bulgaria. This requires in the period 2021-2027 to implement in practice the construction of a new level of government in terms of continuing the process of decentralization to municipalities and districts, and above them to build the regional framework of the 6 planning regions. This issue raises the need for a new discussion and a new vision for the restructuring of the districts at the level of self-government. At least, because the nature and severity of administrative-territorial changes in Bulgaria need effective control over the activities of local authorities and the search for the right balance between development, planning, management and control.



REFERENCES

1. *Analytical report for development and improvement of the administrative - territorial structure of the country and its legal basis - "NCTR" EAD, 2007;*
2. *Dokova, S. (2010) Territorial and administrative structure - Thrace – M;*
3. *Kovachev, Savin (2001) Administrative - territorial structure of the Republic of Bulgaria;*
4. *Marinov, V. Al. Gildzhov, M. Hauser Review of the regional policy of Bulgaria in the process of accession to the European Union. Ed. FLGR 2001;*
5. *Petrov, K. Geoeconomic orientation of the planning regions in Bulgaria. Ed. Avangard Prima, 2008;*
6. *Ruseva Zlatka (2010) Review of the Bulgarian legislation related to local self-government and the administrative-territorial structure in the period 1879-1939;*
7. *Slaveykov PT Karastoyanov .. Portrait of the regions. Sofia, 2000.*



CONDITIONS FOR LEGAL PROTECTION OF INVENTIONS IN THE FIELD OF NANOTECHNOLOGY

Bakhtiyor Usubjonovich Akhmadjonov

Lawyer of Ferghana State University, Candidate of Juridical Sciences (PhD), Ferghana region, Republic of Uzbekistan

Article DOI: <https://doi.org/10.36713/epra5142>

ABSTRACT

The article provides a detailed analysis of the conditions of legal protection of inventions in the field of nanotechnology and the formation of legal norms with the help of materials from the scientific literature.

KEY WORDS: *Nanotechnology, legal norm, protection, invention, science, law, intellectual property.*

INTRODUCTION

The current legislation of Uzbekistan does not contain norms aimed at regulating nanotechnology and related relations. Due to the fact that nanotechnology is the object of intellectual property, in the legislation aimed at the legal regulation of intellectual property (“On Inventions, Utility Models and Industrial Designs”, “On Selection Achievements”, “On Legal Protection of Integrated Circuit Topologies” and other laws) such as nanotechnology. In addition, the fact that nanotechnology is a branch of science and the issues related to their creation and application are still in the process of formation, and the lack of a clear decision on them also obscures the need for the formation of legislation and legislation. in the formation of negilism. Of course, this process is not dogmatic, and the perceptions and views on this issue will become clear after some time, and the need to create a legal framework for nanotechnology will become clearer, and the urgency of the issue will become clear. However, this does not mean that legal science can be excluded from social realities, or that the gap in the legal field will always remain so. On the contrary, the field of jurisprudence must go ahead and, in some cases, in line with modern realities, and determine the basis and procedure of legal regulation. Such a practice serves to prevent future legal conflicts, as well as the development of legal norms in line with modern realities.

METHODS

The uniqueness of nanotechnology as an object of intellectual property is characterized by the fact that the object and direction of creative activity is focused on extremely small objects, and as a result achieves achievements that can not be achieved under normal conditions. Therefore, it is necessary to pay attention to the definition of the essence of nanotechnology as an object of intellectual property, the recognition of the term “nanotechnology” as an object and its recognition as a separate independent object of intellectual property.

RESULTS AND DISCUSSIONS

As noted above, in a number of countries, nanotechnologies are recognized and protected as a form of invention rather than as a separate object of intellectual property. In addition, today a special and separate piece of legislation on the legal status of nanotechnologies has not yet been adopted in any country and is not widely used in law enforcement practice. However, more than half a century has passed since the term nanotechnology was recognized as a separate branch of science, and specific scientific laws have been created in this area. This shows the need and urgency of legal regulation of nanotechnology as a separate area of human scientific and creative activity, and one of the tasks of the legislature to determine the legal order of human scientific and creative activity is the field of nanotechnology. Of course, it should be noted that in



some countries, certain normative documents aimed at the establishment, formation and development of nanotechnology activities have been adopted. For example, in countries such as the Russian Federation, the United States, France, Japan, Germany, certain normative documents on nanotechnology activities, government decisions have been adopted. However, these normative documents are aimed at the organization and formation of nanotechnology activities, which are a type of scientific research activity, and do not provide for the status of nanotechnology as an object of intellectual property.

The status of nanotechnology as an object of intellectual property is becoming more and more common in modern jurisprudence, defined by the legal regime of inventions. In fact, nanotechnologies are close to inventions in terms of their method of creation and practical and technical characteristics. In addition, nanotechnology is close to inventions, as it contributes to the development of technical progress and has a level of novelty and ingenuity. In this regard, it is possible to reveal the criteria for the legal protection of nanotechnological inventions by analyzing the application of the conditions of legal protection of inventions to nanotechnology.

According to Article 6, Part 1 of the Law of the Republic of Uzbekistan "On Inventions, Utility Models and Industrial Designs" of August 29, 2002, if an object specified as an invention has a new, inventive step and can be used in industry, it is legally protected.

According to O. Akyulov, according to US law, an invention must have signs of novelty, usefulness and invisibility. The utility mark does not require an indication of the degree to which the invention is useful. In an explanation given as early as 1817, the U.S. Supreme Court ruled that an invention was sufficient if it could be applied in practice and if the application was not contrary to politics and ethics. In the laws of Uzbekistan and Russia, the sign of industrial application of the invention was not logically correct. In this case, the term used in industry can be considered as incomplete and inaccurate in its content. It was necessary to use the phrase in practice here [1, p.117-118].

If the invention is not known from the level of technical development, it is considered new. According to I.I. Nasriev, patents issued for industrial property under the Law "On Inventions, Utility Models, Industrial Designs" can be disputed during the term of its validity and can be partially or completely revoked. The main reason for such cases may be the novelty of industrial property. In determining the novelty of inventions and utility models, the technical level of applications submitted by applicants across the country plays an important role [2].

According to V.D. Yusupov, the concept of novelty is revealed through the level of technology. An invention is considered new if it does not relate to the level of technical development at the date of application, and the concept of "level of technical development" includes any knowledge that is available to the public through written or oral description or otherwise. Thus, there is an absolute global demand for the invention [3]. According to A.P. Sergeev, the novelty of an invention is determined by its priority date. The priority date is determined by the filing of a patent application with the Patent Office [4].

According to O.Akyulov, the priority date of the application for an object of industrial property begins from the date of registration of the application and its submission to the patent office. It is known that Uzbekistan is a party to the Paris Convention for the Protection of Industrial Property. Therefore, the priority date of the Convention is applied in the territory of the Republic of Uzbekistan [1, p.123-124].

In our view, novelty cannot be attributed to a previously unknown state of affairs relative to an invention. The novelty of the invention is characterized not only by the fact that it has not been the same before, but also by the fact that a solution has been found with respect to substance and method. Only then can the invention be considered new. In nanotechnology, too, innovation is associated with previously unknown, and if it is not known from the level of development of nanotechnology, it can be noted that it is considered new. However, evaluating nanotechnologies only as a solution to an existing technical problem would be a relatively narrow interpretation of their potential. Nanotechnologies not only represent the solution of a technical problem but also the solution of a problem in any sphere of social life and human activity, take the existing substance, body and method to a new level and raise their potential to a new and higher level. For example, the use of nanoproducts in medicine may be safer, more beneficial than previously used substances and methods, and may prolong human life and enhance adverse effects on natural conditions.

In accordance with paragraphs 3-4 of Article 6 of the Law "On Inventions, Utility Models and Industrial Designs", an invention has the degree of invention if it is not clear from the data on the level of technical development. The state of the art includes any information disclosed to the public worldwide prior to the priority date of the invention. Inventive activity is identical to the criterion of "degree of invention", which was previously used in the judicial and administrative practice of a number of countries.

The previous practice of the EU administrative and judicial authorities has developed a number of auxiliary criteria for assessing inventive



activity, which can be considered to have been applied in many countries of the European Patent Convention.

In particular, the following solutions are recognized as inventive activities:

- a solution to a problem that experts have not been able to find for a long time, despite repeated attempts, despite the need;

- the existing invention is not in a position to meet current needs;

- the existence of significant technical difficulties that need to be overcome in the creation of the invention.

Proof of the inventive activity is the elimination of “technical assumptions”, conservatism and “technical blindness” of specialists, which did not allow to find a certain optimal solution, which is clearly visible at the level of technical development.

Based on the criterion of abstraction, it should be noted that in foreign legislation the criterion of technical progress, which was previously considered an invention of enrichment of technical means (GFR, Austria, Switzerland) was abolished. Consequently, the creation of a technical tool or the solution of a task in technical methods satisfies a certain need, which can be considered as enriching the overall level of technical development [5, p.66-67].

According to the general rule, inventions are new equipment, means of production, new working devices that help to solve an existing technical problem in the field of technology and are useful for production. Given the place of inventions in public life and the state economy, their usefulness is considered as the first tool. Given that the invention is usually carried out in the field of technology, most experts consider them as the result of scientific and creative activity aimed at solving a technical problem and the solution of an existing problem [6, p.342-346].

According to S.M. Safoeva, the main purpose of the invention is to find a solution to the problem in the field of technology and its usefulness for industry. An invention is a patent-protected object of intellectual property, which, according to the object of scientific and creative activity, has a special place in the system of intellectual property and differs from other objects of intellectual property by the following features:

- Firstly, of intellectual property, only the invention is the product of research in engineering and industry;

- Secondly, the process of creating inventions is characterized by its complexity and longevity;

- Thirdly, inventions are not included in the list of objects of intellectual property protected after their objective form, but are protected by a special protection document issued by the relevant state body [7]. While the level of invention is associated with a state of “uncertainty”, it should be borne in mind that

the term “level of technical development” is derived from the latest innovations and achievements of modern science. Of course, in the context of globalization and integration, the state of “uncertainty” cannot be linked to the territory or shell of a single country. However, in determining the fact of “obvious ambiguity” it is necessary to take into account that such a solution to the existing problem in relation to the substance or method has not yet been formed at all. Uncertainty at the level of technical development is also related to the date and status of the priority, in which the first application for the protection of the invention serves as the basis for its protection. In nanotechnology, too, the state of uncertainty at the level of technical development is important. It would be more accurate to say that this situation is not clear to them at the level of development of nanotechnology. Such ambiguity is related to the term of the application for legal protection of nanoproducts. In addition, there may be problems in defining the state of “uncertainty” in terms of the confidentiality of advances in nanotechnology.

Another condition for the patentability of inventions is that they can be used in industry. The possibility of application in industry means that the new device, substance or method created represents not only the theoretical existence, but also the solution of an existing technical problem from a practical point of view. In fact, while the invention is considered to be a useful, new and problematic solution in terms of all technical and economic parameters, it must be a complete and widely applied fact in the relevant field. Otherwise, the existence of such an invention and a new only scientific hypothesis will remain a hypothesis, and there will be no specific necessity to protect it from a legal point of view and to define its status as an object of law. The legal literature also contains a number of opinions on the state of industrial applicability of the invention. For example, V.D. Yusupov noted that the criterion of industrial applicability served as a basis for the exclusion of a number of objects from the list of patentable objects, and in this regard, the legislation provides for surgical or therapeutic methods of treatment of humans and animals, as well as diagnostic methods. It has been determined that it does not meet the requirement of industrial applicability [8]. According to I.V. Biryukova, the development of the range of objects recognized as patentable shows that the scope of the subject of patenting is expanding. This is based on the introduction of various new industries in connection with the establishment of protection against objects previously considered incompetent [9].



CONCLUSION

Indeed, while the legislation of each country gives legal protection to an invention, it also takes into account, first and foremost, the question of how the invention will benefit from an economic point of view and the need to pay special attention to its industrial application. The impossibility of industrial application is a ground for refusing to grant a patent for an invention. In the case of nanotechnology, it is possible to examine the feasibility of industrial application and how this technology will benefit and facilitate the relevant industry, and, consequently, to establish legal protection for nanotechnology. In general, any nanotechnological development can be the result of scientific research in terms of novelty, and this fact can be recognized in the field of science. However, if there is no possibility of industrial application of nanotechnological development, it is not subject to legal protection, and the issue of protection as a separate object of intellectual property may be possible only from the point of view of copyright. For example, if a person who violates the theoretical principles of nanotechnology publishes a work in the form of a material carrier, the work is copyrighted and is not protected by a patent as a nanotechnology, as this development can not be used in industry.

REFERENCES

1. *Akyulov O. Theoretical and practical problems of the legal status of intellectual property. -Tashkent, 2004. -p. 117-118.*
2. *Nasriev I.I. Civil law issues of implementation and protection of personal non-property rights. - Tashkent: Gafur Gulom Publishing House, 2006. - 175 p.*
3. *Yusupov V.D. International legal regulation of the protection of intellectual property: Abstract dissertation for the degree Candidate of Juridical Sciences. - Tashkent: 2012.-65 p.*
4. *Sergeev A.P. Civil law. -Moscow: Prospect, 2001. - 418 p.*
5. *Yusupov V.D. International legal regulation of the protection of intellectual property: Abstract dissertation for the degree Candidate of Juridical Sciences.-Tashkent, 2012.-p. 66-67.*
6. *Imomov N. Selection achievements are a specific object of intellectual property // "Civil law of the Republic of Uzbekistan for ten years of its independence". Abstracts of the international scientific and practical conference. -T.2002. p. 342-346*
7. *Safoeva S.M. Forms of commercial use of intellectual property. Study guide.- Tashkent: TSJI, 2009. - 32 p.*
8. *Yusupov V.D. International legal regulation of the protection of intellectual property: Abstract dissertation for the degree Candidate of Juridical Sciences. – Tashkent, 2012.- 68 p.*
9. *Biryukova I.V. Problems of bio patent regulation and its improvement: Abstract dissertation for the degree Candidate of Juridical Sciences. –Tashkent, 2006.*



THE EFFICIENCY OF UP TO DATE PEDAGOGICAL TECHNOLOGIES USAGE IN TEACHING ENGLISH

Akhmedova F.A.

Sam SIFL, English teacher, the chair of Eastern languages

ANNOTATION

This article is about the usage of new pedagogical technologies which can be useful in teaching and learning English. The personal-oriented approach, Training in collaboration, Project method, Multi-level training, New information technologies in teaching English are presently used in teaching and learning process.

KEY WORDS: *The personal-oriented approach, collaboration, Project method, multi-level training, pedagogical and information technologies.*

DISCUSSION

In pedagogical literature, the concept of technology is often found, which came to us together with the development of computer technology and the introduction of new computer technologies. In pedagogical science, a special direction has appeared - *pedagogical technology*. This trend originated in the 60s of the last century in the United States, England and is now spread in almost all countries of the world. Like any technology, pedagogical technology is a process in which there is a qualitative change in the impact on the student.

In contrast to the previously used methodological overtime developments aimed at teachers and their activities, the technology offers a project of the educational process that determines the structure and content of educational and cognitive activities of students. Each teacher perceives methodological development in different ways, therefore, students' activities are organized in different ways. A school graduate must have the necessary knowledge, skills, and skills to carry out various activities, be able to use new information technologies, and be ready to cooperate in an effort to avoid and overcome conflicts. Today, the world pedagogical science considers the teacher as a Manager who manages the active development activities of students. This role is much more complex than in traditional training, and requires a higher level of professional and pedagogical culture, competence, and skill from the teacher.

What can a teacher rely on today? Probably, on modern pedagogical technologies. Pedagogy is rich in technologies that have been successfully used for the past 20 years. The theoretical review of

technologies shows that the most common in practice are technologies of personal-oriented learning, game, problem, information, distance learning, and others. There are also more modern technologies: critical thinking technology, ICT.

Our survey of teachers shows that in practice, teachers use a narrower list of technologies, namely: 70 % of the surveyed teachers often use game and project technologies; 30 % of teachers use critical thinking and ICT technologies. Among the technologies listed by teachers, the following were singled out: teaching in dialogue, technologies of problem and differentiated learning.

The analysis of teachers' judgments allowed us to identify the reasons for the occasional use of technologies, the main ones being the long and energy-intensive preparation for their use in the educational process, and the responsibility for the proper implementation of technology in the training program. There is a contradiction: the technology assumes systematic use to ensure high quality of education, but the teacher does not have a methodological tool for its use in daily practice. One teacher for various reasons (lack of time and abilities for such activities) can not create a methodological development of the educational topic using the selected technology for the subject for the entire academic year. This is possible for researchers and specialists, or creative teams prepared for this activity. Therefore, many teachers do not use technology systematically.

The personal-oriented approach takes into account the personal interests of students and their individual characteristics and creates prerequisites for greater learning effectiveness. This approach creates a



special relationship between students and the teacher, between the students themselves. Personal-oriented training includes the method of projects, training in cooperation.

Training in collaboration. The main idea of this technology is to create conditions for active joint educational activities of students in different educational situations. Students are different: some quickly grasp all the explanations of the teacher, easily master the lexical material, communicative skills; others need not only much more time to understand the material, but also additional examples and explanations. If, in such cases, you combine children in small groups (3-4 people) and give them one common task, specifying the role of each student in the group in performing this task, then there is a situation in which everyone is responsible not only for the result of their work, but, most importantly, for the result of the entire group. In this way, joint efforts eliminate gaps. This is the general idea of learning in collaboration [4; 70-75].

Practice shows that learning together is not only easier and more interesting, but also much more effective. When using collaborative learning, the most difficult thing is to ensure that students in small groups communicate in a foreign language. But practice shows that with enough persistent attention from the teacher, this requirement is fulfilled first with difficulty, and then gradually with obvious pleasure. It should be noted that it is not enough to form groups and give them the appropriate task. The point is that the student wants to acquire knowledge himself.

Project method. The methods and technologies of the personal - oriented approach in teaching foreign languages include the project method. The project method is a set of educational and cognitive techniques that allow you to solve a particular problem as a result of independent actions of students with mandatory presentation of these results. Project technology includes a set of research and search methods that are creative in their very essence [2; 129-130].

It is known that learning a foreign language makes a significant contribution to the overall development. The project method is the essence of the developing, personality-oriented nature of training. The quiz as a research project method gives students the opportunity to participate in a research search. The quiz allows the teacher to have informal contact with students, who are easier and more accessible to go to it when they are busy with something interesting, helps to build trusting relationships, build communication based on a friendly location.

Multi-level training. By multi-level training, we mean the organization of the educational process, in which each student has the opportunity to master the educational material for individual subjects of the school program at different levels, but not below the

basic level, depending on their abilities and individual characteristics. At the same time, the student's efforts to master this material and use it creatively are taken as a criterion for evaluating the student's activity.

New information technologies in teaching English. Currently, new information technologies, such as the use of Internet resources, training computer programs, etc., have become intensively introduced into the educational process.

Computers have rapidly entered our lives and into the process of learning English and are a means of teaching children. Now the teacher has a lot of educational programs on CD-ROM with tests, training exercises. Students show a genuine and lively interest in working on computers with such training disks, which is advisable to use in the educational process. The use of computers in English lessons significantly increases the intensity of the learning process, and a much larger amount of material is absorbed than was done at the same time in traditional learning. In addition, the material is absorbed more strongly when using a computer [5; 78-92].

The use of ICT makes it possible to:

- 1) Present the material more clearly, in less time, with more understanding on the part of students;
- 2) Attract passive listeners;
- 3) Make classes more visual;
- 4) Provide instant feedback;
- 5) Save time for speech practice;
- 6) Organize individual, group, and front - end work with the class;
- 7) simplify the control of students ' learning activities;
- 8) Provide the learning process with new, previously unavailable materials that help students show their creative abilities

Use of information and communication technologies in the education system

The use of multimedia learning tools in foreign language lessons and extracurricular activities increases the cognitive activity and motivation of students, provides independent activity of students. Interactive programs and games help to create real communication situations, remove psychological barriers and increase interest in the subject. So, let's call the most frequently used elements of ICT in the educational process: electronic textbooks and manuals demonstrated using a computer and a multimedia projector, interactive whiteboard, electronic encyclopedias and reference books, simulators and testing programs, educational resources of the Internet, and CD-ROMs with pictures and illustrations, video and audio equipment, research works and projects; distance learning [1;224-230].

The inclusion of students in educational activities is carried out on the basis of a system-activity



approach, in which four types of lessons are distinguished depending on their goals: lessons of "discovery" of new knowledge; lessons of reflection; lessons of General methodological orientation (generalization, consolidation, systematization of the studied material); lessons of developing control; where ICT can be effectively used in a wide variety of communicative situations, taking into account the personal characteristics of students. In my practice, I use multimedia abstracts created specifically for specific lessons-presentations containing a short text, basic language formulas, diagrams, drawings, animations, and demonstration of a sequence of actions on a computer to perform the practical part of the work, often with simultaneous duplication of actions by students at their workplaces.

When using multimedia presentations in the process of explaining a new topic, a linear sequence of frames is sufficient, in which the most winning moments of the topic can be shown. The screen can also display definitions and diagrams that students write off in a notebook (if there are technical capabilities, a short summary of the presentation content is printed for each student), which allows you to use developmental types of tasks at the repetition stage. Having such an opportunity as interactivity, computer presentations allow you to effectively adapt the training material to the characteristics of students. Increased interactivity leads to more intensive participation in the learning process of the student, which helps to improve the efficiency of perception and memorization of educational material [1; 230–237].

Lesson of knowledge consolidation. Currently, computer support for the English language course has been developed. Without replacing a textbook or other teaching AIDS, electronic publications have their own didactic functions. The main role is played by different material, the use of which varies by the teacher. In practice, I use software for an interactive whiteboard, which visually presents the material, provides quick feedback (instant control over the assimilation of the material). Interactive mode allows students to control the speed of the study material themselves; the branched structure of hyperlinks allows you to get an explanation, additional information).

Lesson of systematization and generalization of knowledge. In these lessons, we directly address various sources of information that is interesting to students and helps them gain life experience.

Independent search for the necessary information on English-language and thematic sites helps to form compensatory, socio-cultural competence, develops the ability to organize independent work. A variety of activities form cross-subject skills through filling out electronic questionnaires; working with geographical maps; working with English-language sites [4; 67–70].

Lesson of developing control. I believe that the use of computer testing increases the efficiency of the educational process, activates the cognitive activity of students. The tests I develop are variants of cards with questions, the answers to which the student writes in a notebook or on a special answer form. In the electronic version, at the request of the teacher, the slide change can be configured to automatically go through a certain time interval. When creating a test with a choice of the answer on the computer, I indicate the conclusion of the reaction about the correctness (not correctness) of the choice made or without specifying the correctness of the choice made.

You can provide the option to re-select the answer. Based on the results of such tests, you can judge the degree of readiness and desire of students to study this section.

The effectiveness of the lessons increases due to the use of different types of jobs (debates, discussions, role-playing), a compact combination of all kinds of speech activity (listening, speaking, reading and writing), the actual information content, orientation, learning student. Moreover, the use of interactive forms of learning contributes to the fact that the student himself becomes the main active figure in the formation of his individual development route, i.e., the humanitarian self-organization of the student's personality.

The constantly developing information support system, combined with technical support, ensures the quality of the educational process.

Innovative projects are of interest because they create conditions for a real language environment, on the basis of which the need to communicate in a foreign language is formed and, as a result, the need to learn a foreign language. Pedagogical, information and communication technologies ensure high performance of the lesson.

BIBLIOGRAPHY

1. Abik M., Ajhoun, R., Ensias, L. *Impact of technological advancement on pedagogy. Turkish Online Journal of Distance Education*, 13(1), 2010.-P. 224–237.
2. Bozalek V., Gachago, D., Alexander, L., Watters, K., J. *The use of emerging technologies for authentic learning: British Journal of Educational Technology*, 44(4), 2013.-P.129–138
3. Cochran K. F., King, R. A., DeRuiter, J. A. *Pedagogical content knowledge: A tentative model for teacher preparation*, 1991.-P.67–100
4. Cox S. *A conceptual analysis of technological pedagogical content knowledge framework.* - Provo, UT: Brigham Young University, 2008.-P.78–92.



SYNTACTICAL MEANS EXPRESSING THE EXPRESSIVITY IN A SCIENTIFIC TEXT

N. Ochilova

Scientific-Researcher, Samarkand state institute of foreign languages

ANNOTATION

The article discusses the syntactic means of expressing expression in a scientific text in the example of English texts. The author concludes that the analysis shows that the function of interrogative sentences in a scientific text is more multifaceted and differentiated than in other types of texts.

KEY WORDS: *syntactic, expressive, predicative, emotional, semantic, constructive, qualitative, pragmatic, rhetorical, illusionary.*

Средства выражения **экспрессивности** образуют целостную систему. Главная особенность этой системы состоит в том, что она охватывает единицы разных уровней языка. Центр этой системы, конечно же, занимают словарные единицы. Некоторые исследователи синтаксических единиц не могут отказаться от традиции размещения их на границах системы (см., например, Шарова 2002: 4). В научном дискурсе сфера применения эмоционально-оценочных словарных единиц уже, и именно синтаксические средства выразительности занимают место из центра поля. Но синтаксические приемы научной речи, склонные к экспрессивности, не были изучены на достаточном уровне.

В число экспрессивных структур обычно включаются предложения, имеющие субмодальное значение, то есть выражающие отношение говорящего к данному сообщению или к определенной его части. Экспрессивные синтаксические конструкции - это приемы, которые формируются как альтернатива намеренному отступлению от стилистических норм языка и приданию тексту дополнительной экспрессивно- эмоциональной окраски. Эти приемы, направленные на прагматическое воздействие речевых движений, могут, без всякого подозрения, быть включены в резерв экспрессивных единиц языка.

Некоторые исследователи предпочитают исследовать систему синтаксических средств экспрессивности с точки зрения теории поля

(Настратова 2004: 121). С центра этой области занимают место единицы с высокой степенью **экспрессивности** и воздействия (например, восклицательные предложения). Причем границы квадрата занимают единицы с меньшей степенью **экспрессивности**, и эти языковые единицы будут иметь различные модальные окраски, помимо того, что они выполняют номинативные задачи определенного вида. Учитывая такие показатели, экспрессоров на границе тоже можно разделить на две группы: если первая группа приближается к центру, а вторая группа, конечно же, удаляется от центра.

Обобщающая абстрактность является одной из основных черт научного стиля и эта особенность проявляется в широком применении безличных форм глагола (герундия, прилагательное, инфинитив) и в активности безличных единиц вместо личных местоимений. Простые предложения тоже часто состоят из безличных конструкций, и в таких предложениях в роли подлежащего выступают дополнение, обстоятельство или предикат. Эту позицию займет безличный *it*-элемент конечно, эта ожидаемая ситуация. Бипредикативные (двупредикативные) предложения выполняют задачу соединения информации, упомянутой в предыдущей части изложения, с дополнительной информацией, выраженной в другой части.

Вообще, в научных текстах синтаксические средства имеют сложную структурную взаимосвязь. Полипредикативные



предложения используются в этих текстах с целью выражения последовательности событий.

Сравните:

It is not clear why the process should be more affective for trimethylarionium than for trimethylphosphonium because it might have been anticipated that owing to their more diffuse nature the 4d orbitals of arsenic would be less efficient in forming 2 p – 4 d bonds than would the 3d orbitals of phosphorus in similar bond – formation (Journal of the Chemical, 1998: 3875).

Взаимозависимость частей затрудняет экспрессивность содержания текста:

If you are an inveterate experimenter and if you read Russian – especially the Russian electronics hobbyist journal, Radio – the title of this article may stir a memory (Popular Electronics, 1999. - № 4:68).

Для полипредикативных предложений в последовательной подчинительной структуре характерно взаимное подчинение частей. Именно такая особенность синтаксических конструкций характерна для оглавления научно-технических текстов. Известно, что в таких текстах информация, предназначенная автором, передается на основе систематического сочетания информационно коммуникативных единиц. Анализ научных текстов, написанных в разных жанрах, показывает, что передаваемая информация распределяется по своему содержанию по-разному. В частности, когда информация состоит из инструкций (машины, оборудование, информация об эксплуатации материала), эта информация излагается по частям. Самое интересное, что при отбрасывании одной из выделенных частей сужается только информационный масштаб, не нанося ущерба общему содержанию текста.

Сравните:

Chattering of brushes is sometimes experienced on direct – current machines. Chattering under certain conditions may become so prominent as to not only be of annoyance, but as actually break the carbones. An examination of the commutator will reveal no roughness, the surface being, perhaps, perfectly smooth and bright. This trouble occurs principally with the type of brush holder which has a box guide for the carbon. The spring which forces the brush into contact rests on top of the carbon which has fairly free play in the box guide. Chattering usually occurs with high – speed commutators, running at 4000 to 5000 ft. per min. peripheral speed (American Electrician's Handbook, 2001: 240).

Основной элемент тематики цитируемого текста найти сложно, так как замена некоторых предложений в его составе никак не влияет на общее содержание. В этом случае наряду с признанием того, что основная часть содержания выражена в третьем предложении, выражение

экспрессивности можно увидеть в описании способа предотвращения колебания.

Экспрессивность присуща и текстам иной структурной конструкции. Например, иногда после заголовка вдруг приводится информация о предмете, а в более поздних частях текста информация описывается подробно, с учетом "мелочи". Сравните:

1. Synchrosopes are instruments that indicate the difference in phase between two electromotive forces at every instant. They show whether the machine to be synchronized is running fast or slow and indicate the exact instant when the machines are in synchronism. The companies that manufacture the instruments furnish literature describing the theory involved and that gives complete circuit diagrams (American Electrician's Handbook, 2001: 253).

2. Reserpine, Reserpine is considered one of the most potent of the Rauwolfes alkoids, which exhibit a sedative action and antihypertensive effect (Journal of American Pharmacological association, 2008. Vol. XLV: 4-5).

Текст научной статьи, в котором излагаются результаты исследования, имеет особую структуру, в них информация распределяется несколько иным образом.

Статьи, публикуемые по заказу специальных журналов, должны состоять из таких частей, как название, аннотация, введение, описание материала и методов анализа, полученные результаты и их обсуждение. Опытные читатели этих журналов знают, что основное содержание текста и выводы автора необходимо искать с конца статьи. В таких случаях само заглавие, указывая на содержание сообщения, занимает самое важное место в тексте. А "вводная" часть не имеет столь важное значение. Следующая глава основана на цели и задачах исследования. Хотя часть об описании материала и методов, используемых в процессе исследования, кажется незначительной в исходном контексте, но ее изложение не лишена от эмоциональной окраски. Сравните:

Chlorobenzene. The laboratory grade was dried (CaCl₂) and fractionated through a packed column. It was then dried (P₂ O₅) again and fractionated twice more. The final product had b.p. 151, 8 / 759 mm., nd 20 5.1.5243. Timmerman gives b.p. 132 / 760 mm. (Journal of Chemical Society, 1998 № 6: 3864).

Такие структуры замедляют восприятие информации и требуют повышенного внимания со стороны читателя. А экспрессивность текста проявляется в показанных отрицательных эмоциях.

При выражении информации в текстах научного жанра "основная нагрузка" ложится на



заключительную часть. В этой главе обобщаются основные достижения и выводы исследования. И поэтому автор, пытающийся убедить читателя в правильности своих выводов, вынужден прибегать к различным методам. Выбор синтаксических средств также должен отвечать этим требованиям.

Как уже отмечалось выше, в научном тексте центральную часть выражающих синтаксических средств функционально-семантического поля составляют восклицательные предложения. Если в устной речи эмоциональное значение этих типов речевых структур выражается с помощью интонации, то в письменной речи применяется восклицательный знак (!).

Если восклицательные предложения, с одной стороны, могут выражать констативно речевой акт в повествовательно-восклицательной форме, а с другой стороны они могут образовывать квестивный речевой акт в вопросительно-восклицательной форме. Два варианта речевых актов в этой форме также способствует усугублению экспрессивности содержания, вызывая интерес у читателя, подтверждая достоверность информации, возникающей на основе сведений, приведенных в предыдущей части текста. Использование восклицательных предложений в научной речи преследует цель привлечения внимания слушателя к той информации мысли, которая представляется автору важной. Автор средством восклицания призывает адресата выразить своё отношение к сказанной мысли. Например: biochemist

I think that having heard the truly passionate appeal of the biologists the biochemist should raise his humble voice! (Biochemistry of Ribosomes 1989: 653).

Distance night put truth on a pedestal! Each incident concerning Burton has more than one version. In such a dilemma time might be more reliable in that it reveals everything, even that which was never there. And time leaves everything behind. It has many uses (Allan Sillitoe. Raw material. – L.: Pan Books, 1994: 20).

В научных текстах часто встречается последовательное использование восклицательных и вопросительных предложений:

And although Empson's comments still apply the original effect of the poem has evaporated!

Why! We have to explain why rewriting a poem destroys much of its effect. After all, it does not seem that Davie would think so. His comments, like Empson's, fail to do the poem justice. The clue, possibly is the assumption that the syntax is missing because the verbs are. On the contrary, what we have

is the skilfull use of syntax to mine the meaning. The syntax is not missing! It is being used to better effect (Cluysenaar A. Intraduction to Literary Stylistics, 1996: 53).

Как видно из отрывка из данного текста, вместо того, чтоб излагать факты автор предпочитает заставить читателя размышлять. Используемые лингвистические средства порождают субмодальное содержание в образе автора. Помимо фраз: after all, it does not seem, possibly, to a better effect сюда входят восклицательные и вопросительные формы.

Кроме того, последовательность восклицательных и вопросительных предложений в тексте служит установлению связи с читателем, создаёт возможность перехода от научного общения в диалог.

В качестве примера можно привести следующий фрагмент: Literary study always demands the analysis of material! How should it be done? Regarding the modes of transmission of story material, we must first define concretely our major distinction: summary narrative (telling) vs. immediate scene (showing). The particular type: summary narrative is a generalized account, immediate scene emerges as soon as the specific, continuous, and successive details of time, place, action, character and dialogue begin to appear (Freedman N. The point of view in fiction, 1989: 119).

В этом отрывке из статьи Фрийдмана "Точка зрения автора в художественной прозе" восклицательные и вопросительные конструкции выполняют роль предикативного сообщения, привлекая внимание читателя к последующим комментариям и тем самым служат для концентрации внимания.

Восклицательное предложение также иногда используется для того, чтобы завершить комментарий, которые были объяснены ранее:

Transcribing spoken discourse is challenging and often frustrating, not to mention time-consuming: some linguists spend close to ten hours transcribing just one hour of speech. But fortunately, what results is a transcript that they can analyze from different angles years after original speech. The process of transcribing is also very instructive (Heysse T. Truth and a Theory of Argumentation 1991: 86).

Во всех приведенных выше примерах отражены чувства автора по поводу содержания раскрываемой информации. Действительно, в первых местах текста подчеркивается важность мысли, выраженной через восклицательное предложение, а в следующих, к удивлению, проявляются случаи непонимания до конца. Когда эти восклицательные предложения переносятся в форму повествования, можно



наблюдать потерю эмоциональности и уменьшение силы воздействия речевой деятельности.

Проведенный анализ свидетельствует о том, что применение восклицательных предложений в научном тексте связано с целью привлечения внимания читателя к значительной части результатов исследования. Кроме того, когда автор выражает эмоционально-субъективное отношение к сообщаемой информации, он обращается и к восклицательной форме. По исследованиям Сафарова Ш. и Т. А. Шишкина в контексте диалога восклицания изображаются разные цели и интенции автора-повествователя и при этом первичные и вторичные иллокуции начинают взаимодействовать, а вторичные иллокуции, такие как совет, просьба, могут выйти на первый план. В таких случаях эмоциональные свойства речевых структур нуждаются в дополнительном выражении (Сафаров, Шишкина, 1990: 127).

Why do so many researches in DA and CDA refer to Foucault's concepts while emphasizing simultaneously power relations and activities, obviously performed by actors? (Panagl O. Text and Context, 2004: 132).

В данном примере текст автора представляет собой скрытую форму диалога, в котором создается впечатление, что он разговаривает со своим читателем, и применение его внимания при таком способе передачи направлено на формирование проблемы, которую планируется изучить. Такой способ прагматистического высказывания отражает коммуникативную природу языка, то есть учитывается адресат. Соответственно, мы включим риторический вопрос в ряд факторов, создающих экспрессивность научной речи. Автор пытается осмыслить научные факты, которые обсуждаются через него, объяснить их ясно и понятно.

Известно, что в научном дискурсе цель побуждения адресата к рассуждению посредством речевого действия может быть выражена как открыто, так и тайно. Если рассмотреть выражение этой коммуникативной цели в закрытой или эксплицитной форме в деятельности императивных (повелительных) форм, то существует множество типов закрытых (имплицитных) средств выражения. Например, конструкции типа Let us try the experiment.... (Francis N. Social and Educational 1997: 32); Let us briefly investigate (Spitzer L. American Advertising.... 2001); Take this specimen (Mellinkoff D. The Language of the Law, 1982) мы сравниваем с такими вопросами Do we see it? (Trilling L. Art and fortune, 1990: 35); do we publicize...? (Gold R. The vernacular of jazz, 1994:

142); Not very encouraging, what? (Kazin A. The alone generation, 1990: 43). Если предыдущие три структуры имеют форму императива с функцией приглашения, то последние являются риторическими вопросами. В текстах с участием императивных форм речевой акт приказа или приглашения выражается внешне. Даже при наличии риторических вопросов присутствие адресанта в общении представляется мнимым, но вышеприведенная иллокуция косвенно исчезает.

Для того чтобы определить функции вопросительных предложений в процессе речевой деятельности, необходимо наблюдать их чередование со структурами в форме условного наклонения. Сравните:

(a) I call upon those who are interested in this problem to take up the making of the modals in the field of the biosynthesis of organic phosphorus compound (Biochemistry of Ribosomes... 1998: 654);

(b) I should like to raise protest against reference to virus particles to molecules (Biochemistry and Ribosomes... 1998: 372);

(c) Would Dr. Spirin comment on that? (Biochemistry and Ribosomes... 1998: 140);

(d) Is it not possible to explain the higher amount of the 40 S subunit in cell sap by a preferential detachment of this subunit from membrane bound ribosomes? (Biochemistry and Ribosomes... 1998: 567).

Во всех приведенных примерах действует речевой акт призыва к действию. Но эти директивные разговорные акты имеют разное значение, и этому способствует разнообразие языковых средств. Следовательно, если фраза I should like структуры (a) более приспособлена к выражению смысла призыва, чем желания, то фраза to raise a protest в составе (b) образует смысл оппозиции к идее.

Первая из структур в форме вопроса (c) стала средством косвенного выражения иллокации "пожалуйста". Следующий вопросительное (d) необходимо будет рассматривать как речевой акт, в котором рассматривается предложение об описании или интерпретации анализируемого явления. Это, в свою очередь, свидетельствует о наличии семи мотивации действия в семантике вопросительных предложений (Косарева 1982: 14).

Вопросно-ответные комплексы, формирующиеся в научных текстах, являются результатом воздействия устной речи на дискурсы различных жанров. Кстати, понятно, что задача вопросительных предложений в научных текстах специфична. Если в устной речи структуры вопроса преимущественно фатические, то есть он функционирует как связь, то в анализируемых нами текстах двигают его



мышление, привлекая внимание адресата к тому или иному рассуждению или выводу.

Еще одна особенность вопросно-ответной структуры в композиции научного текста проявляется в том, что автор сам отвечает на поставленный вопрос. Предполагается, что этот вопрос задан самим читателем. Кроме того, связь между частями вопросно-ответной структуры является прочной, и случаи их удаления друг от друга наблюдаются редко. Это один из активных процессов, происходящих в языковой системе, то есть следствие быстрого усвоения единицы устной речи в методике письменного литературного языка. Например:

The debate about context leads us to the chapter on "pretext". What is pretext? The term "pretext" generally refers to an ulterior motive: a pretending to do one thing but intending to do something else (Schiffrin D. *Approaches to Discourse*, 1994:47).

В приведенном примере цель обращения автора к форме вопроса состоит в том, чтобы привлечь читателя к контексту высказывания и противопоставить ему свои интеллектуальные способности.

Структура вопроса-ответа в составе научных текстов служит для разделения выраженной информации на части. Хотя рассматриваемое предложение в этих условиях выполняет разные задачи, но самыми основными из них являются обозначение (вместе с определением предмета ответа, планированием прагматического обозначения), вызов на спор, оценка, как бы.

Отличие структур так называемых "Диалогических связей" от структур предыдущего вопроса состоит в том, что вопрос и ответ будут прочно связаны друг с другом в плане субъектной, лексической и синтаксической структуры. Даже иногда части теряют свою содержательную и синтаксическую самостоятельность. С их помощью автор пытается донести свои мысли непосредственно до читателя, заставляя его искать ответ на поставленный вместе вопрос.

Сравните:

But why destroyers and devours? And what about impossible cases? Destruction and devouring are actions in which an entity ceases to exist (Stern K. *Argumentation and Convictive Force*, 1991: 33).

Представленные отрывки указывают на разделение информации на части в диалогических ссылках и наличие основной части в ответной реплике.

В некоторых случаях такая структура речи позволяет говорящему предвидеть возражения слушателя и подготовить для него подходящий ответ:

But what is there about language that lets us engage in so wide a range of activities? Certainly sounds, morphemes, lexical items, and sentences are part of the story, sounds produce acoustic signals that combine to convey propositions that are systematically arranged into grammatical strings. But what happens then? A sound, morpheme, word, sentence, or proposition almost never occurs on its own. They are put together in discourse (Schiffrin D. *Approaches to Discourse*, 1994: 314).

В научной литературе вопросительные предложения иногда употребляются в виде полной цепочки, образующей последовательность авторских мыслей. Здесь цель обращения к методу изложения состоит в том, чтобы поставить на лидирующие позиции ту часть информации, которую автор считает важной. Сравните:

I regard this part as the core of the book because it leads readers through the most complex and difficult aspects of DA: How do we define a "topic" of a text? Which are the most relevant cohesive devices? What are the salient characteristics of multimodal discourses in relevant to other genres, such as conversations, or written documents, or even electronic media?

In sum, this section enables readers to confront the "hard work" of detailed and explicit linguistic analysis in a systematic way (Woodak R. *Understanding the concept of Discourse*, 2004: 242).

Используя цепочку вопросительных предложений, автор побуждает читателя искать решение обсуждаемой проблемы. Ответ на этот вопрос должен быть ясен. Этот тип высказывания в основном специфичен для спорных ситуаций, а при изложении выводов исследования не используются вопросительные предложения.

Таким образом, проведенный анализ показывает, что функция вопросительных предложений в научном тексте более многогранна и дифференцирована, чем в других типах текстов. В этом жанре вопросительные предложения направлены не только на необходимость реплики ответа, но и на ускорение интеллектуальной деятельности читателя, привлечение его внимания. Использование вопросительных структур в научном дискурсе подчинено определенной коммуникативной и прагматической цели.

Список использованной литературы

1. Косарева В.А. *Вопросительно – отрицательные предложения в современном английском языке. Автореф. дисс... канд. филол. наук. – Л., 1982. – 23 с.*
2. Нистратова С.Л. *Об экспрессивности синтаксических средств научной речи // Язык, сознание, коммуникация. – М.: МАКС Пресс, 2004. – С. 118-132.*



3. Сафаров Ш. С., Шишкина Т.А. Коммуникативно – прагматические функции восклицания в диалоге // Мышление и коммуникация. – М.: 1990. – С. 126-131.
4. Шарова В.В. Категория экспрессивности в русском языке (на фоне английского языка). Автореф. дисс.... канд.филол.наук. – СПб., 2002. – 20 с.
5. *American Electrician's Handbook*. – New York, 2001.
6. *Biochemistry of Ribosomes and Messenger RNA*. – Berlin, 1998.
7. Cluysenaar A. *Introduction to Literary Stylistics*. – L.: B.T. Batsford, 1996.
8. Francis N. *Social and educational varieties of English*. – Boston, 1997.
9. Gold R. *The vernacular of jazz*. – New York, 1994.
10. Heysse T. *Truth and a Theory of Argumentation // Proceedings of the 2d International Conference of Argumentation*. – Austerdam, 1991.
11. *Journal of Chemical Society*. – 1998. №. 6.
12. *Journal of the American Pharmaceutical Association*: 2008. vol. XLV. №. 5.
13. Kazin A. *The alone generation // The American novel since World War II*. – Greenwich, 1990.
14. Mellinkoff D. *The Language of the law*. – Boston, 1982.
15. Panagl O. *The point of view in fiction // The theory of the novel*. – New York: Free Press, 1986.
16. *Popular Electronics*. – 1999. №. 4.
17. *Research as verbal Behavior and some Neurophysiologist Implication*. – New York, 2007.
18. Schiffrin D. *Approaches to Discourse*. – Oxford: Blackwell, 1994.
19. Spitzer L. *American advertizing explained as popular art // Essays on English and American literature*. – Princeton, 2001.
20. Stern K. *Argumentation and Convictive Force // Proceedings of the International Conference*. – Amsterdam, 1991.
21. Trilling L. *Art and fortune*. – Greenwich, 1990.
22. Woodak R. *Understanding the concept of Discourse // Text und Kontext*. - Wurzburg: 2004.



INFORMATION SEEKING BEHAVIOR ABOUT COVID-19 AND CONTAINMENT ZONES: A STUDY IN ODISHA

Dr. Yajnya Dutta Nayak

Assistant Professor, PG Dept. of Commerce, Khallikote Auto. College, Berhampur.

Mr. Aditya Prasad Sahoo

PhD Research Scholar, KIIT University

Dr. Manas Ranjan Mishra

Assistant Professor, Department of English, Gopalpur College, Gopalpur

ABSTRACT

The COVID-19 outburst is a global pandemic with communal flow in several countries, containing the United States, with definite cases in all states. The progression of this pandemic will be molded by how governments endorse sensible strategies and publicize information by considering the public reactions towards different policies and information. In this paper, the authors examine the information-seeking behavior of public towards the COVID-19 infection cases and containment zones exclusively in the state of Odisha.

KEY WORDS: COVID-19, Information, Infection, Pandemic, Awareness

1. INTRODUCTION

The pandemic outburst of COVID-19 has enforced a perilous status quo of public health among the world. Efforts have been made in the direction of safeguarding proper levels of awareness and response to fight the disease effectively and efficiently and to control the consequences related with the outbreak. Information is the key element of any society seemed to be most critical that must be prepared well to safeguard the society from the disease and also analyze the capability to handle the situation if any individual is infected or inveterate in COVID-19. Consequently, various governments have specified highest importance to that aspect through implementing several strategies in protection of community such as initiating wide-scale COVID-19 campaigns to spread awareness, rules for quarantine and delegating lockdown procedures comprising the

shutting of schools and workplaces. Conversely, in the light of these annoying circumstances of COVID-19 burst, the questions arise in this perspective is obvious that how the public is interested to find timely preparation of COVID-19 information, COVID-19 patient number, and behavior of individuals toward containment zone for protecting their family as well as combat the disease.

2. INFORMATION SEEKING BEHAVIOR TOWARDS COVID-19 IN ODISHA

Several countries have enforced far-reaching lockdown by putting massive effort to mitigate the COVID-19 outbreak. The usefulness of these mitigation actions is extremely reliant on cooperation and, coordination, and compliance of the whole society. The information seeking behavior of the



public toward the diseases is vital to find out their determination and willingness to assent behavioral change measures from health authorities. The main theme of this study is to govern the understanding, outlooks and practices toward COVID-19 among the individuals in the state of Odisha.

Information seeking behavior is an unambiguous notion of information behavior. It is specially emphasizes on searching, discovering, and repossessing information. Information seeking behavior research includes need of information, improving the information system and observing the behavior of the respondent or users. Information-seeking behavior (ISB) concept is usually defined in the research as an energetic or persistent behavior accepted by an individual to find facts and figures about the pandemic. The perception has been repeatedly deliberated in the milieu of lasting diseases like diabetes and cancer. On the other hand, narrow literature is found examining ISB of patients or healthy individuals for the period of a pandemic outbreak. Moreover, few studies have been steered to observe ISB of public during the COVID-19 outbreak. Therefore, this study enthusiastically explores this behavioral perspective of the public in relation to their information requirements, fonts of data, hurdles, and fulfillment with overall prevailing sources. This could be helpful to create health awareness and raising efforts in this pandemic situation to get rid of anxiety, panic, and depression in Odisha.

3. SOURCES OF INFORMATION ON COVID-19 IN ODISHA

Unlike the other disease in recent history, the flourishing spread of coronavirus has brought the world to its knees. In Odisha there is a chance to avoid the explosion of virus as the virus is not touched its potential effusively. Odisha government is taking various steps to confine all redundant human movement, but that has opened another window of wave of fake news and partial-truths as individuals are required to stay at home for the probable future.

In this dismal circumstance, creation of panic can be destructive too. To evade the consequence of incorrect information, awareness is must for every happening. The public must keep the resources to know the particular situation of the coronavirus in India and should avoid all the negative sagas that are associated with it. Some relevant sources of getting information on COVID-19 are government official statements, social media, newspaper, and Corona virus dashboard and awareness campaign.

Government official statements include government report, government clarification on present condition of coronavirus through conducting press meets, official members interview and opinion. Similarly, in case of social media, Facebook, WhatsApp, Twitter, are playing vital role in spreading the relevant information on Covid-19. Newspapers and news channels both remain on the top in circulating relevant information on COVID-19 outbreak, infection numbers, containment zones, and government measures to restrict coronavirus and safety measures. In order to avoid wrong and dubious information, Government of India introduced COVID-19 dashboard, an online tracker to know the current coronavirus infection number, recovery number and deaths. Apart from that different awareness campaigns on Coronavirus like symptoms, safety measures, precautions, sanitization, hand-wash, etc. are done by the government.

4. OBJECTIVES OF THE STUDY

1. To know the public interest towards COVID-19 cases in Odisha.
2. To find out the public behavior towards containment zones in Odisha.
3. To know the information seeking behavior of public towards COVID-19 in Odisha.

5. SOURCES OF DATA COLLECTION

In this study data collection is based on two sources. One is primary source which includes sampling and questionnaire and another is secondary source like government report, internet, journals, periodicals, newspaper, etc. Primary data include the preparation of questionnaire and distributing it in three cities in Odisha. Those cities are Cuttack, Bhubaneswar, and Berhampur. All Total 155 samples have been collected. From Cuttack 45. From Bhubaneswar 52 and from Berhampur 58 samples have been taken into consideration to analyze the information seeking behavior of the community towards COVID-19 cases and containment zones. Statistical tool is used to know the behavioral perspective of public and by this means finding their interest and behavior towards this pandemic scenario.

**6. DATA ANALYSIS AND INTERPRETATION****A. Demographical behaviour of respondents about information seeking behaviour**

City	Gender		Age			Profession				Edu. Qualification			
	M	F	YE	ME	OE	GE	PE	BM	HW	UP	MT	GT	PS
Cuttack (45)	73.33	26.67	15.56	55.55	28.89	22.22	37.78	28.89	13.33	11.11	28.89	40	20
BBSR (52)	67.31	32.69	17.31	55.77	38.46	23.08	38.46	30.77	7.69	5.76	26.92	40.38	26.92
Berhampur (58)	67.24	32.76	11.76	44.83	37.93	15.52	24.14	53.45	6.89	10.34	36.21	41.38	12.07
Total (155)													

(M.: Male, F: Female, GE: Govt. Employee, PE: Private Employees, MB, Business man, HW house Wife, YE: youth Age, ME: Middle Age, OE: Old Age, UP: Up to primary, MT: 10th pass, GT: graduate, PS: professionals' qualification.)

This present table shows demographical profile of the respondents of Cuttack, Bhubaneswar and Berhampur cities of Odisha. On the analysis, it is observed that, majority of respondents are male in all study cities. And the highest percent of respondents belong to middle aged group. In case of profession of

respondent majority of respondents are business men at Berhampur city as like as most of the respondents are private employees at Cuttack and BBSR city. The majority 40 % of employees are graduates and below 30 %of employees are professional degree holder both in Cuttack and BBSR city.

B. Frequency of visit For Sources Information Regarding Information Seeking Behaviour on Covid -19

City	Media (TV) (155)			Social media (FB, WA, etc) (155)			Other sources (F/N/R) (155)			
	Always	5-10 times in a day	2-3 times in a day	Always	5-10 times in a day	2-3 times in a day	Always	5-10 times in a day	2-3 times in a day	Not asked
Cuttack (45)	40	44.44	15.56	60	28.89	11.11	6.66	15.56	31.11	46.67
BBSR (52)	48.08	40.38	11.54	55.78	30.76	13.46	3.85	11.54	21.15	63.46
Berhampur (58)	37.93	48.28	13.79	51.72	31.04	17.24	12.07	15.52	29.31	43.10
Total (155)										

From this table It is observed that majority of respondents among Cuttack, BBSR, and Berhampur City visited Media (TV) always 5-10 times in a day for sources information regarding COVID-19 because, most of time they are staying at home i.e. Lock down period. But very few numbers of respondents are open TV channel 2-3 times in a week to know on covid-19 and public infection, similarly, 50-60 percents of respondents are visited Social media (FB, WhatsApp etc.) Always (time to tome)

day for instant news on Covid -19, public or local infection, contentment zones death etc. While, most of respondent are no like to prefer or believe any public discussion or opinion regarding infection, medicine treatment, death, etc

**C.Purpose of visit For Sources Information Regarding Information Seeking Behaviour on Covid -19**

Responses	Govt. publication and media	Percent	Public discussion and social media	Percent	Total
Know about no of infection spared	134	86.45	21	13.55	155
Know about contentment zone	103	66.45	52	33.55	155
To know about Govt. Information and instruction	146	94.19	9	5.81	155
To know about public infection	86	55.48	69	44.52	155
To know about medicine and treatment	129	83.23	26	16.77	155
to find public death	75	48.39	80	51.61	155
To know about short down and luck down	137	88.39	18	11.61	155
Find about govt plan & policies on Covid	116	74.84	39	25.16	155
CHI-SQUARE ESTIMATE= 156.3753 Degrees of freedom= 7 Results = Highly Significance (P < 0.001)					

It is observed that 86.45 percent out of 155 respondents among respondents visited the Govt. publication and media to know about infection spared, 66.45 percent respondents to know about contentment zone, 94.19 percent respondents visited the TV channel or media or government sites to know about Govt. Information. 55.48 percent visited media or government sites to know about public infection. 83.23 percent visited TV channel or media to know about medicine and treatment sources. 48.39 percent respondents visited TV channel or media to find public death. 88.39 percent visited to know about short down and luck down. While 74.84 percent revisited for government plan & policies on Covid.

Similarly, It is also observed that out of 155 respondents, 13.55 percent of respondents are like to

visited the social media and public opinion to Know about infection spared, 33.55 percent respondents to Know about contentment zone, 5.81 percent respondents preferred the social media or public opinion for to know about Govt. Information. 44.52 percent visited social media or public opinion to know about public infection. 16.77 percent visited social media or public discussion to know about medicine and treatment sources. 51.61 percent respondents visited media or public discussion to find public death. 11.61 percent visited to know about short down and luck down. While 25.16 percent are visited for government plan & policies on Covid.

This fact is tested statistically by applying Chi-square Test and result come out to be highly significant. So, Chi-square test's result are conforming that respondents Responses towards



information seeking behaviour towards covid 19 and sources of information are depended each other.

7. FINDINGS

- Most of the respondents are male and middle-aged group in this study. Because male and middle-aged people are balancing their family and realise about social challenges and problems.
- Majority of the respondents are businessman and private employees with graduate to professional qualification. They are like to seeking information about covid 19 for their, business, job income and family maintenance etc. Because most of the private employees ate already lost their basic job due to first spread of covid-19. Like this govt also declared to not to open market regular or full day as per rule in covid-19 period.
- majority of respondents among Cuttack, BBSR, and Berhampur City visited Media (TV) always 5-10 times in a day for sources information regarding COVID-19 because, most of time they are staying at home i.e. lock down period.
- Most of the respondents are like to prefer Govt. publication and media as sources of information for Know about no of infection spared, Govt. Information and instruction, short down and luck down, medicine and treatment etc.
- Some of the respondents are like for Public discussion and social media as major sources of information know about contentment zone due to not publish details in media and government sites.
- Some of the respondents are like to Public discussion and social media as major sources of information to know about public infection and to find public or local death due to not publish details in media and govt sites.

8. CONCLUSION AND SUGGESTION

Man is constantly in need information for knowledge and wisdom. Information on COVID-19 is considered as the elements in the search for wisdom in a human process in the pandemic period. Information seeking is the process of finding the right information on contentment zoon, area of infection, state and district wise infection and govt. policies at right time. On the basis of forgoing discussion, the following conclusion are made regarding the information seeking behaviour of the public. The government officials are officially well and the public are enriching knowledge and information on COVID-19 by using media and

social media. The sample is well versed in using COVID-19 information through officials, media, social media, public discussion in getting their required information. The suggestion received from the respondents are as follows: explain and disclose the contentment zone, declare the area of spread, declare the no of infection sate and district wise, declare the local death, regarding health check-up awareness etc. The sample need current information for death, spread, contentment zone and medicine and treatment are the main purpose for information seeking behaviour. Media, Govt. publication, social media like: Face Book, WhatsApp, you tube, tutors and public discussion are the most privileged sources of communication about COVID-19. It is concluded that the implementation of COVID-19 management technique and introduction on innovative strategy for easy retrieval would create a favourable environment in regarding and maximising the reaching output on Covid-19. Its high time that the govt and officials are very careful towards COVID-19 patents identification and create awareness among the public about the infection spread, contentment zone, area of spread, no of infection sate and district wise, local death, health check-up for creating better healthy society. And Govt. should take the initiatives to procure and disclose COVID-19 data base and information for benefit of society. The significant role of Government is to provide sufficient and effective services to the public at the right time by reducing the COVID-19 infection. Let us walk towards the healthy and innovation based digitised India as well world with strategic COVID-19 management.

9. REFERENCES

1. Covell, D. G., Uman, G. C. & Manning, P. R. Information needs in office practice. Are they being met? *Annals of Internal Medicine* 1985, **103**, 596– 9.
2. Ali, I. Library provided information and clinical decision making: a study of two hospitals in Canberra. *Australian Academic and Research Libraries* 2000, **31**, 30– 45.
3. Andrews, J. E., Pearce, K. A., Ireson, C. & Love, M. M. Information-seeking behaviours of practitioners in a primary care practice-based research network (PBRN). *Journal of the Medical Library Association* 2005, **93**, 206– 12.
4. Arroll, B., Pandit, S., Kerins, D., Tracey, J. & Kerse, N. Use of information sources among New Zealand family physicians with high access to computers. *Journal of Family Practice Online* 2002, **51**.
5. Bennett, N. L., Casebeer, L. L., Kristofco, R. E. & Strasser, S. M. Physicians' Internet information-seeking behaviours. *The Journal of Continuing Education in the Health Professions* 2004, **24**, 31– 8.



6. Allen, B. L. and Kim, K-S. 2001. *Person and context in information seeking: interaction between cognitive and task variables. New Review of Information Behavior Research, Vol. 2: 1-16.*
7. Borgman, C. 1989. *All users of information retrieval systems are not created equal: An exploration into individual differences. Information Processing and Management, Vol. 25, no.3: 237-251.*
8. Case, D. O. 2002. *Looking for information: a survey of research on information seeking, needs and behavior. Amsterdam: Academic Press.*
9. Fairer-Wessels, Felicité A. 1990. *Basic community information needs of urban black women in Mamelodi, Pretoria, South Africa. South African Journal of Library and Information Science, Vol. 58: 359- 369.*
10. Ford, N. 2004. *Modelling cognitive processes in information seeking: from popper to pask, Journal of the American Society for Information Science and Technology, Vol. 55, no. 9: 769-782.*
11. Griffiths, J. M. 1982. *The value of information and related systems, products and services. In M. E. Williams (Eds.), Annual Review of Information Science and Technology, Vol. 17: 269-284.*
12. Heinstrom, J. 2003. *Five personality dimensions and their influence on information behavior. Information Research, Vol. 9, no.1.*
13. Iselin, E. 1989. *The Impact of information diversity on information overload effects in unstructured managerial decision making. Journal of Information Science, Vol. 15, no. 3: 163-173.*



MAIN DIRECTIONS OF IMPLEMENTATION OF THE STATE YOUTH POLICY IN THE REPUBLIC OF UZBEKISTAN

¹*Jumayev Axmamat Shermamatovich*

¹*Associate professor of the department of Pedagogy and psychology of Uzbek State World Languages University, Doctor of Philosophy in Pedagogical Sciences (PhD)*

ABSTRACT

Increasing youth activity is an important factor in the development of our country. A significant part of the population of Uzbekistan consists of young people, who serve as a guarantee of a great future for the country. This article describes the main directions of implementation of state youth policy, the principles of state youth policy, the work done in recent years on youth issues in the Republic of Uzbekistan during the years of independence.

KEYWORDS: *young generation, state youth policy, Youth Union of Uzbekistan.*

DISCUSSION

During the years of independence, a lot of work has been carried out in our country to educate young people in the spirit of patriotism, respect for national traditions and values, to bring up a spiritually mature and physically healthy generation, to protect their rights and interests. Today, more than 60% of the total population of Uzbekistan are 18 million strong, courageous and enthusiastic young citizens. That is why youth policy is reflected in all strategies aimed at ensuring the sustainability of state development. Today in Uzbekistan, all the necessary conditions are being created for young people to realize their life goals. The problems of the youth are being solved at the level of state policy. The Law of the Republic of Uzbekistan "On State Youth Policy" adopted in order to radically improve the activities in this area [2] has created a solid legal basis for bringing up young people who will be perfect, independent-minded, able to take responsibility for the future of our country, enterprising, mobilizing their potential in the interests of the people, realizing their intellectual and creative potential.

The state youth policy in our country is formed and conducted on the basis of the following principles:

- Caring for young people, regardless of their nationality, race, language, religion and political beliefs;
- Legal and social protection of youth;

- Ensuring national, cultural and spiritual ties of generations;

- Supporting youth initiatives, guaranteeing their protection of their rights and interests within the framework of the Constitution and laws of the Republic of Uzbekistan;

- Ensuring the direct participation of young people in the formation of policies and programs for the development of society;

- Unity of rights and obligations, freedom and responsibility.

It should be noted that the Action Strategies for the five priority areas of development of the Republic of Uzbekistan for 2017-2021 [1] identifies a number of new and important tasks related to increasing youth participation in reforms to build a democratic state and civil society. On June 30, 2017, a new page was opened in the life of the country's youth. At the initiative of the President of the Republic of Uzbekistan, Youth Union of Uzbekistan was established, the main activities of which are aimed at supporting and implementing all youth initiatives. At the initiative of the head of state, June 30 was declared Youth Day for the first time in the history of Uzbekistan. The law "On the celebration of Youth Day in the Republic of Uzbekistan" was adopted. Priorities for the activities of the Youth Union of Uzbekistan have been identified.

In accordance with the decree, the following were included in the priorities of Youth Union of Uzbekistan:



First, to transform Youth Union of Uzbekistan into a professional structure under the motto "The youth are the builder of the future", providing effective cooperation with government agencies, non-governmental organizations and other civil society institutions in the implementation of state youth policy in the country;

Secondly, to protect the rights, freedoms and legal interests of young people, to educate them in the spirit of respect for national and universal values, commitment to the ideas of independence in the mind and heart, to understand national identity, to develop a sense of patriotism, devotion to the motherland and its destiny, protection from various ideological threats;

Thirdly, to increase the activity of young people in the reforms aimed at building a democratic state and the development of civil society, to expand the ranks of young people with high spirituality, independent thinking, strong life position, broad outlook and deep knowledge, initiative, courage, mobilizing all their strength, knowledge and potential for the benefit of the country, able to take responsibility for the future of the country.

Fourth, to create favorable conditions for young people to master modern professions, to provide employment, to develop entrepreneurial skills, to involve them in small business and private entrepreneurship, to encourage their initiatives, to help them realize their intellectual and creative potential;

Fifth, to increase the interest of young people in reading scientific and art books, including electronic works, formation of a strong immunity against various ideological threats, in particular, religious extremism, terrorism, "popular culture" and other alien ideas, by raising the culture of use of legal, environmental, medical and information and communication technologies;

Sixth, the implementation of effective measures aimed at promoting the ideas of a healthy lifestyle and family sanctity among young people, preventing early marriage and divorce of young families;

Seventh, the wide involvement of young people in sports and physical education, creative circles and various courses, including foreign language courses, in order to meaningfully organize the leisure time of their non-organized part;

Eighth, the organization of targeted work aimed at providing moral and material support to young families, in particular, young people with disabilities and those in need of social protection, the creation of decent housing and social conditions for them;

Ninth, active participation in the early prevention and prophylaxis of delinquency and crime among young people;

Tenth, to educate, create a reserve of educated, enterprising, honest and selfless young leaders who will take an active part in the ongoing reforms in the country, who will faithfully serve the interests of the people, and recommend them to responsible positions in state and economic administration;

Eleventh, further development of international cooperation in the field of youth policy, implementation of measures aimed at protecting the rights and interests of young people studying and working abroad;

Twelfth, to provide ideological and methodological assistance to state and economic administration bodies, non-governmental non-profit organizations and other civil society institutions in organizing youth activities [3]

Furthermore, over the past two years, more than 40 regulations on youth issues have been developed. The Legislative Chamber of the Oliy Majlis has established a commission on youth issues and a "Youth Club". Interdepartmental Councils on youth issues have been established under the leadership of the Prime Minister and under the chairmanship of governors in the regions.

In the local executive and internal affairs bodies, new state units have been introduced - the position of Deputy Governor for Youth Affairs and Deputy Chief of Internal Affairs.

Today, more than 23,000 primary organizations of Youth Union operate in all educational institutions and ministries, departments and government agencies. To date, Youth Union has brought together about 11 million young people.

At the initiative of the Youth Union, 26 non-governmental non-profit organizations, including the Republican Center for Social and Psychological Assistance to Youth, the Center for Youth and Children with Disabilities, the Republican Council of Young Scientists, the Council of Young Farmers, the Youth Tourism Agency, the World Youth Association of Uzbekistan, The Republican creative youth council, the Youth Media Center, the Youth Publishing House and others were established.

The Institute for the Study of Youth Problems and Training of Prospective Personnel under the Academy of Public Administration under the President of the Republic of Uzbekistan has been established.

To conclude, the adoption of the new Law "On State Youth Policy" means that the legal guarantees of social and economic rights and interests of young people in Uzbekistan are becoming stronger, and in the future the country's youth will reach new heights and make a worthy contribution to the country's development. As President Mirziyoyev said at the 72nd UN Summit in front of the international community, "... the future and prosperity of our planet depends on how our children



bring up. Our main task is to create the necessary conditions for young people to show their potential, to prevent the spread of the "virus" of the idea of violence. To do this, it is necessary to develop multilateral cooperation in the field of social support of the younger generation, protection of their rights and interests [4].

LIST OF USED LITERATURE

1. *Scientific-methodical booklet on the study of the State Program for the implementation of the Action Strategies on the five priority areas of development of the Republic of Uzbekistan in 2017-2021 in the "Year of dialogue with the people and the interests of man." T, 2017. p.197*
2. *National database of the legislation of the Republic of Uzbekistan:*
<https://www.lex.uz/docs/3026246>
3. www.nrm.uz
4. <http://uza.uz>



A STUDY ON CUSTOMER SATISFACTION TOWARDS ONLINE CAB BOOKING WITH SPECIAL REFERENCE TO COIMBATORE CITY

Dr. S. Suguna

*Associate Professor, Department of Commerce with Professional Accounting,
Dr. N.G.P. Arts and Science College, Coimbatore.*

M.Rohini

*Student of III B.Com.(PA), Department of Commerce with Professional Accounting,
Dr.N.G.P Arts and Science College, Coimbatore.*

ABSTRACT

In the present situation, travel and transportation is becoming very popular amongst millions of travelers around the world. It is also one of the biggest demands of many people since it is compulsory for them to travel around the world. We need to travel from one place to another place in our daily life due to many factors. For making travels, you need to hire cab. Are you looking for the best step to have cab booking strategy? If yes, then you have arrived here at the right online portal where you could get the best cab services online.

INTRODUCTION

In the past decade the transportation facilities in urban areas have undergone tremendous changes. Among various modes of transportation the cabs have become important mode of transportation metropolitan cities and urban cities in India. The growth of organized car rental industry is continuously growing with support of technology. The customers in the present era are using mobile apps to book a cab at any time and from one place in urban areas, the pricing strategy of cab operators had been positively influencing customers book a cab instead of traditional mode of transportation like autos and local buses etc., like most of the industries the car rental industries had underwent lot of transformation with internet technology. The customers are able to access book cabs at competitive prices because of tough competition among the original cab operators.

Call taxis are the services in India in several cities in India. In some cities, they operate under a regular taxi permit, while in some cities; they are treated as tourist vehicle for hire. They often offer services at all times of the day. Call taxi services are not officially recognized by the water vehicles act. They are proffered as they are considered as safer as, more convenient than ordinary taxis or auto rickshaws and reliable. In Mumbai, ordinary taxi cabs can be booked over the internet or with a phone.

A call taxi is a type of vehicle for hire with a driver, used by a single passenger or small group of passenger for a non-shared ride. A call taxi conveys passenger's location by the services provider, not by the passenger, although demand and share taxis provide a hybrid taxi mode.

Ola in particular, has been grown explosively over the past years. Aimed at solving the intra city commuting problems of, customers, these radio cab services have perfectly capitalized



on the growing engagement with the smart phones and the need for convenient to commute to different destinations at different times of the day, by offering car rides at prices lower than the fairer charges charged by auto rickshaws. Earlier cabs were mostly used for airports rides that as changes now because of the unrivalled ease of access offered by mobile apps.

All the large companies including Ola and Uber get a majority of their business from mobile based apps. Establishing a number one position in the taxi market and maintaining it indicates that Ola has service to offer to the market which are better than the other services provides from the same segment. The customer satisfaction is the term often used in marketing concept. It is a measure of how products and services supplied by a company meets or exceed customer expectation. Thus, expectation of the customers is the key factor behind the level of satisfaction.

STATEMENT OF THE PROBLEM

Coimbatore has the lot of call taxis which are facing tough competition in our today's world. Nowadays, the customers can prefer any call taxi but the important thing is that they want to like the service rendered by them. In order to maintain its brand, expectation and the level of satisfaction of its customers should be considered more. So the necessity has arisen to identify the level of customer satisfaction towards Ola cabs and to know about the psychology of the people in preferring the Ola cabs.

SCOPE OF STUDY

This study is helpful in knowing the factors responsible for gaining customer satisfaction towards cabs services in Coimbatore city. It focuses on the opinion of the resonance regarding cab services. Research is also helpful in understanding the customer satisfaction of the different people in Indian society especially Coimbatore city towards cabs services.

OBJECTIVE OF STUDY

- To analyse the customer satisfaction towards cabs in Coimbatore city.
- To study the factors which influence people to use cabs in Coimbatore City.
- To ascertain the customer view towards the driver behavior
- To know the problem faced by customers while using cabs in Coimbatore city.

STATISTICAL TOOL USED

- ✓ Simple percentage analysis
- ✓ Likert scale analysis

LIMITATION OF STUDY

- This study is carried out only in Coimbatore City
- Findings of the study are purely depends on the responses provided by the respondents
- The sample size taken for the study is limited only to 150 respondents

REVIEW OF LITERATURE

Mr. MAI NGOC KHUONG and NGO QUANG DAI, (2016) entitled in "The Factors affecting customer satisfaction and customer loyalty. A study of local taxi companies in Ho Chi Minh city, Vietnam. They have followed on; one of their key challenges they face is how to manage service quality, which is provided for satisfaction customers, retaining them and creating loyalty among customers. The satisfy the basic mobility need of the individual, the demand for transport services come into play. The business of transportation is developed with severe competitions, fluctuations, and new challenges. Nowadays, consumer becomes wiser and they require not only high quality but also better, more professional in service. The local companies are facing with the new companies which are Uber, Grab and Easy.

Mr. DIPESH BHAWANANI, DIMPLE BOHRA (2015), entitled in "Big Data Analytics on cab company's customer dataset using Hive and Tableau", The company has focused on analysing the dataset of the customer which help in analyse their frequent customers, The company has understand and provided the offers to them and they also analysed travel and package used by the customers. Cab companies will be able to manage its vendors and about Customer cancellations. Their goal is to reduce their cost. The company could make necessary arrangement of particular cab like small cabs, luxury cabs, buses etc.

Dr. ASHOKKUMAR PANIGRAHI AMAR SINGH RATHORE, (2018) entitled in "Success story of a start up a case study of OLA cabs. They have focused on start-up has failed because the founders get boxed, discouraged or something else. Ola has seen a tremendous growth in taxi market. It is the largest cab in the country. As the competition in the Radio Taxi market is increasing at a very faster rate where several brands are providing cabs to the customer as per the



requirements, this paper is designed to study the success story of Ola cabs which has the greater market share and provides services in an efficient manner along with customer satisfaction. Ola picked Facebook over advanced media implies in light of the fact that it has biggest client base crosswise over India. Today it is the largest, cab service provider in the country.

Mr.SAI ALYAN KUNAR SARVEPALLI, Dr. N.R. MOHAN PRAKASH (2016)

entitled in "Cab aggregation industry in Indian an overview, current scenario, issues and possible for consolidation. They focused on there are usually referred to as taxi aggregates, cab aggregators or car aggregators and management research termininology. The arrival of Uber and Ola service become very popular in all major cities. The taxi aggregation industry in India how the aggregation innovatively provided the solution innovatively using technology.

DATA ANALYSIS AND INTERPRETATION

The data collected from the samples have systematically applied and presented in the tables under various headings in the following pages. They were also arranged in such a way that, a detailed analysis can; be made so as to present suitable interpretation for the same. The data have been analyzed using the following statistical tools.

- Percentage analysis
- Likert scale analysis

PERCENTAGE ANALYSIS:

The percentage analysis is mainly used to specify the number of respondents in the sample falling in each category. Further, it is also used as a standard for comparison purpose. A number of respondents distribution shows the number of frequencies in various classes, which helps to get preliminary idea with respect to objectives under study. To interpret the results comprehensively percentage value are computed.

FORMULA

PERCENTAGE =

Number of respondents

* 100

_____ / Total number of respondents

**TABLE NO: 1
GENDER OF THE RESPONDENTS**

SI.NO	Gender	NO. OF RESPONDENT	PERCENTAGE
1	MALE	50	41%
2	FEMALE	72	59%
	TOTAL	120	100

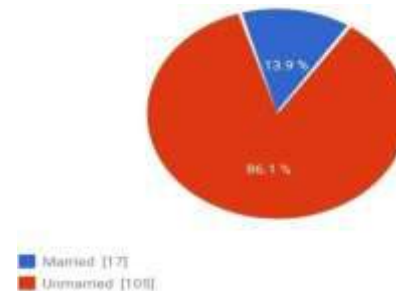

ITERPRRETATION

The above table shows that Gender of the respondents. Out of total 120 respondents, 41% of the respondents are male and 59% of the respondents are female.

Table 2:

S. No	Factors	No.of Respondent	Percentage
1	Married	15	14
2	Unmarried	105	86
	Total	120	100

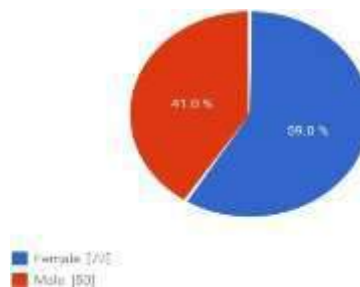

ITERPRRETATION

The above table 4.1.3 indicate that marital Status of the Respondents. Out total 120 respondents 14% of the respondents are married and 86% of the respondents are unmarried.



LIKERT SCALE ANALYSIS

A Likert scale analysis is a method of meaning attitude. Ordinal scale of responses to a question or statement, ordered in hierarchical from strongly negative to strongly positive. Used mainly in behavioural science, in likert's method a person's attitude is measured by combining (additional or averaging) their responses all items

FORMULA:

Likert scale =

$\frac{\sum (FX)}{\text{Total number of respondents}}$

F = Number of Respondents

X = Likert Scale Value

(FX) = Total Scale

Table 4:

TABLE SHOWS THE TIMELY ARRIVAL OF THE CAB

S. No	Factors	No. of Respondents	Likert scale	Total
1	Strongly agree	16	5	80
2	Agree	64	4	256
3	Neutral	39	3	117
4	Disagree	3	2	6
5	Strongly disagree	0	1	0
	Total	120		459

Likert Value = $\frac{fx}{\text{no. of respondents}}$
 = $\frac{459}{120}$
 = 3.76

INTERPRETATION

Likert scale value is 3.76 is greater than the mid value (3) so the respondents agree that cab arrive in time.

FINDINGS, SUGGESTIONS AND CONCLUSION

Finding

- Majority 59% of the respondents are female.
- Majority 86% of the respondents are between 18-25 Years.
- Majority 86% of the respondents are unmarried.
- Majority 64% of the respondents' are in nuclear family.
- Majority 38% of the respondents are professional.

- Majority 72% of the respondents are under graduates.
- Majority 55% of the respondents' are earning an annual income less than Rs.100, 000.
- Majority 55% of the respondents are aware of Ola cabs.
- Majority 67% of the respondents is booking through taxi app.
- Majority 71% of the respondents travel occasionally.
- Majority 45% of the respondent's average journey time is less than 1 hour.
- Majority 51% of the respondents using taxi for personal travel.
- Majority 43% of the respondents are using taxi for convenience.
- Majority 60% of the respondents prefer A/C taxi.
- Majority 78% of the respondents are influenced price for choosing transport.
- Majority 72% of the respondents receive the money back after cancellation.
- Majority 54% of the respondents prefer Ola.
- Majority 33% of the respondents prefer to travel in Prime.
- Majority 62% of respondents are not aware of feedback line.

SUGGESTIONS

Respondents have suggested their valuable comments in questionnaire. The following are the list of suggested comments by respondents

- The service providers can have audio recording service to ensure safety and discipline. May accommodate motion sensors or heart rate monitors may not breach passenger's privacy but provide security in extreme conditions.
- May cabs can avoid high prices for short rides and Avoid Peak time over charge.
- Cab providers to improve availability of cars in rural areas and improve customer services.
- Need to improve taxi availability at 24/7 duration and transparent fare system when compared to various other providers.



- Driver should be more responsible in taking the passengers to destinations.
- Every driver should respect women and also need special care for women and kids. So, lady driver should be allotted. Concentrate more on security and special consideration should be taken for women during night travel.
- Passengers should have option to cease engine remotely in case of emergency while travelling in cabs.
- Provide your services continuously even during heavy rains and at same available pricing.

CONCLUSION

On the whole, Cab providers are excellently providing quality service to travellers. Customers using cabs attitude are changing consistently and expecting many more add-on benefits in future. As per survey on Taxi industry revenues are gradually declining in Indian Society. In Coimbatore half of the passengers are ready to access cabs than using public transport mode and they are not considering the cost charged by cab services. Customers are always king in every business. So, cab providers have to run in the

race and adopt to offer many innovative facilities for customers to increase revenue for this industry.

REFERENCE

1. Mr. MAI NGOC KHUONG and NGO QUANG DAI, (2016) entitled in "The Factors affecting customer satisfaction and customer loyalty. A study of local taxi companies in Ho Chi Minh city, Vietnam.
2. Mr. DIPESH BHAWANANI, ASHISH SANWLANI, HARESH AHUJA, DIMPLE BOHRA (2015), entitled in "Big Data Analytics on Cab Company's customer dataset using Hive and Tableau",
3. UTSAV PANDYA, RISHI RUNGTA, GEETHA LYER (2017) ENTITLED in "IMPACT OF USE OF MOBLIE APPS OF OLA CABS AND TAXI FOR SURE ON YELLOW AND BLACKCABS"
4. ANIKET KULKARNI AND GAURAV METHA GSE Red (2018) Entitled in OLA/UBER: UNDERSTANDING OF UNREGULATED BLUE OCEAN STRATEGY
5. THADPHOOTHON, JANPHA FACULTY OF ART, DHURAKIJ PUNDIT UNIVERSITY, BANGKOK, THAILAND (2017) entitled in "A study on that taxi driver's cross-cultural communication problems and challenges.
6. Ms. RUCHIKAMALIK, (2017) entitled in "Managing partner Performance, Engagement & Retention



EFFECT OF PROCESSING ON PROXIMATE COMPOSITION OF JACKFRUIT (*Artocarpus heterophyllus* Lam.) SEED FLOUR

Sylvia Borgis¹

¹PhD Scholar, Department of Food Science and Nutrition, College of Community Science, University of Agricultural Sciences, Dharwad- 580 005, Karnataka, India

Pushpa Bharati²

²Professor, Department of Food Science and Nutrition, College of Community Science, University of Agricultural Sciences, Dharwad- 580 005, Karnataka, India

ABSTRACT

Jackfruit a tropical fruit possess 100-400 seeds which are oval, brown and edible after processing. A study was undertaken to investigate 'effect of processing on proximate composition of jackfruit seed flour'. Hard variety of jackfruits were procured from a single tree situated on University of Agricultural Sciences, Dharwad campus. Ripe fruits were cut, seeds separated and analyzed for physical quality characteristics. Further seeds were processed employing: boiling, pressure cooking, pan roasting, microwave roasting, baking. Unprocessed seeds served as control. The seeds were milled to flour and analyzed proximate composition. Protein, fat, ash was significantly higher in dry processed seed flour, whereas wet processing significantly increased moisture content. Pressure cooked and boiled jackfruit seeds had significantly higher moisture content of 11.84 and 11.42 per cent respectively whereas, dry processed seeds had significantly low moisture content. The protein content ranged from 11.68 percent in unprocessed seed flour to 14.42 per cent in baked seed flour. Boiling (1.04 ± 0.05 %) and pressure cooking (1.03 ± 0.03 %) resulted in significantly lower fat content. Crude fibre was significantly higher in pressure cooked seed flour (3.96 ± 0.01 %) and lower in baked seed flour (3.73 ± 0.03). The ash content ranged from 3.61 ± 0.02 per cent in unprocessed to 2.93 ± 0.04 per cent in pressure cooked seed flour. Total carbohydrate content of seed flour ranged from 68.57 to 67.56 per cent while available carbohydrate ranged from 72.30 to 71.03 per cent. Dry processing resulted in significant increase in energy with baked seed flour having higher energy content of 340 ± 4.00 kcal. Wet processing significantly decreased the energy with pressure cooked seed flour having lower energy content of 330 ± 3.00 kcal. Processing significantly influenced nutrient composition of jackfruit seed flour. Hence processed flour can be used in product development and value addition to enhance nutritional benefits.

KEY WORDS: Dry processing, flour, jackfruit seed, moist processing, proximate

INTRODUCTION

Jackfruit (*Artocarpus heterophyllus* Lam.) is the largest tree-borne fruit native to India. It belongs to family Moraceae. Mainly, jackfruit pulps are consumed, while rind, core and seeds are utilized as animal feed or discarded. Seeds are oval, ellipsoid or round in shape, having length of 2-4 cm and thickness

of 1.5–2.5 cm. A single fruit may comprise 100 - 400 seeds. Though jackfruit seeds are consumed and are also source of starch for industries, their utilization is limited. Jackfruits being highly seasonal, seeds are available only during month from March to July.

Macronutrients are required for growth and development of body. Carbohydrate, protein, fats etc.



play an important role in providing energy to body, wear and tear of tissues and muscle building. These compositions are important in determining nutritive value of foods and play an important role in formulating food products. Jackfruit seeds are good source of nutrients and their consumption needs to be enhanced. Processing is known to improve palatability, nutritional quality and digestibility of foods. Numerous studies regarding jackfruit seeds are available, but systematic studies on the effect of processing are scanty. Hence, the present study was undertaken with the objective to analyze the effect of processing on proximate composition of jackfruit seed flour.

MATERIALS AND METHODS

Hard variety of jackfruits were procured from a single tree situated on University of Agricultural Sciences, Dharwad campus. Ripe fruits were cut and seeds were separated. Randomly ten jackfruit seeds were selected and analyzed for physical quality characteristics like colour, shape, size, weight and bulk density were recorded. Seed color and shape were recorded by visual observation, size in terms of length, width and thickness was recorded using vernier caliper (Kaushik *et al.*, 2007), weight and volume was noted using electronic balance and water displacement method respectively (Naik, 1991). Bulk density was calculated (Khattak *et al.*, 2007).

Seeds were processed employing common methods of cooking: **1) Boiling** – 50g of seeds was transferred to a vessel containing boiling water, and boiled with closed lid at 100°C till soft and cooked. **2) Pressure cooking** – 50 g of seeds was transferred to a vessel containing 20 ml water. Pressure cooked at 121°C till soft and cooked. From 1 and 2, water was drained, superfluous water was removed from seeds by dabbing on absorbent paper and cooled. **3) Pan roasting** - Seeds were roasted in a heated pan at 160°C with continuous agitation till sweet aroma developed and cooled. **4) Microwave roasting** – 50g of seeds were microwave roasted at 480 Power till the seeds turned soft, sweet and developed roasted aroma and cooled. **5) Baking** – Seeds were baked in pre-heated oven at 180°C till soft and sweet aroma developed for 15 min and cooled. Unprocessed seeds served as control.

Processed seeds were milled to flour and analyzed for proximate composition like moisture, protein, fat, crude fibre and ash (Anon., 2000). Total carbohydrate was calculated by deducting the total sum of percent values of moisture, protein, fat, ash and crude fibre from 100, available carbohydrate was calculated by deducting the total sum of percent value of moisture, protein, fat and ash from 100 (Anon.,

2000). Mean, standard deviation and analysis of variance (One-way ANOVA) was applied to the results. All the analysis was done using SPSS software (version 16.0).

RESULTS AND DISCUSSION

Physical quality characteristics of jackfruit seeds (Table 1 See Appendix) like colour, shape, size, weight, volume, bulk density, length, width, thickness determine the quality, acceptability and marketability. Jackfruit seeds were brown in colour, oval in shape and weighed 5.47 ± 0.76 g, volume 5.25 ± 0.32 ml and bulk density 1.06 ± 0.05 per seed. On an average each seed was 3.52 cm long, 1.77 cm wide and 1.27 cm thick having length to width ratio of 2:1. The values are in comparison with results reported by Airani (2007), Butool and Butool (2013) and Islam *et al.* (2015) wherein seeds were 2 - 4 cm long and 1.5 - 2.5 cm thick. Slightly lower values for length (2 - 3 cm) and width (1 - 1.5 cm) of seeds were mentioned by Abraham and Jayamuthunagai (2014). Variations can be attributed to the differences in variety, maturity index, location and climatic conditions of cultivation.

Proximate composition in processed jackfruit seed flour are presented in Table 2 (See Appendix). Protein, fat, ash was significantly higher in dry processed seed flour, whereas wet processing significantly increased moisture content. Pressure cooked and boiled jackfruit seeds had moisture content of 11.84 and 11.42 per cent respectively whereas, dry processed seeds had significantly low moisture content ranging from 9.17 per cent in baked to 9.72 per cent in pan roasted. Moisture content increased in moist processing due to absorption of water. Dry processing reduced moisture due to removal of moisture and volatile compounds.

The protein content ranged from 11.68 percent in unprocessed seed flour to 14.42 per cent in baked seed flour. Dry processing significantly increased protein content of seed flour, baking reporting higher value (14.42 ± 0.23 %) followed by pan roasting (14.21 ± 0.20 %) and microwave roasting (13.71 ± 0.16 %). Pressure cooked and boiled seed flour had protein content of 13.17 ± 0.04 and 12.74 ± 0.16 per cent respectively. Release of bound nitrogen or non-protein nitrogenous compound might have increased protein content over raw seeds. Similar results were reported by Akubor and Obiegbuna (2014) and Ejiofor *et al.* (2014).

Boiling (1.04 ± 0.05 %) and pressure cooking (1.03 ± 0.03 %) resulted in significantly lower fat content whereas baked (1.21 ± 0.03 %), microwave roasted (1.16 ± 0.03 %) and pan roasted (1.14 ± 0.08 %) seed flour did not differ significantly with



unprocessed seed flour (1.15 ± 0.05 %). Significant decrease in fat content of wet processed seeds can be attributed to leaching out of oil during cooking and may be due to evaporation of volatile fatty acids (Ijeh *et al.*, 2010 and Okafor *et al.*, 2015).

Pressure cooking significantly increased crude fibre content of seed flour (3.96 ± 0.01 %). Crude fibre content in boiled (3.84 ± 0.05 %), microwave roasted (3.83 ± 0.03 %) and pan roasted (3.80 ± 0.01 %) seed flour did not differ significantly, whereas, that in baked seed flour was significantly less. The results are comparable with values reported by Hettiaratchi *et al.* (2011) and Azeez *et al.* (2015) in jackfruit seed flour. Increase in fibre on dry processing may be due to formation of resistant starch and dextrins (Ramula and Rao, 1997).

The ash content in unprocessed, pan roasted, microwave roasted and baked seed flour was 3.61 ± 0.02 , 3.67 ± 0.12 , 3.84 ± 0.11 and 3.67 ± 0.36 per cent respectively, while pressure cooked seed flour exhibited significantly lower ash content of 2.93 ± 0.04 per cent. Significantly lower ash content in wet processed seed flour can be reasoned to leaching out of soluble minerals such as calcium chloride, chlorides of sodium and potassium etc. (Dakare *et al.*, 2014; Akubor and Obiegbuna, 2014 and Okafor *et al.*, 2015).

Total carbohydrate content of seed flour ranged from 68.57 to 67.56 per cent while available carbohydrate ranged from 72.30 to 71.03 per cent. Unprocessed jackfruit seed flour had significantly higher total and available carbohydrate content of 68.57 and 72.30 per cent respectively. Processed seed flour did not differ significantly in carbohydrate content. Decreased moisture, protein, fat, ash and fibre content in unprocessed seed flour have contributed to the increase in carbohydrate as it was computed by subtracting sum of these nutrients from 100.

Dry processing resulted in significant increase in energy with baked seed flour having higher energy content of 340 ± 4.00 kcal followed by microwave roasting (337 ± 4.00 kcal) and pan roasting (336 ± 3.00 kcal). Wet processing significantly decreased the energy with pressure cooked (330 ± 3.00 kcal) and boiled seed flour (332 ± 3.00 kcal) having lower energy content. Unprocessed seed flour possessed 331 ± 3.00 kcal of energy. Higher protein and fat content in baked seed flour resulted in higher energy. Hence, processing significantly impacted proximate composition of jackfruit seed flour.

CONCLUSION

Jackfruit seeds are good source of nutrients. Processing improves nutritional value in terms of protein, fat, ash, crude fibre and energy. As jackfruit

seeds are perishable, flour is a best alternative for consumption, storage and further usage. Hence, flour of processed jackfruit seeds can be used for product development and value addition at domestic, commercial and industrial level for nutritional security.

REFERENCES

1. Abraham, A and Jayamuthunagai, J., 2014, An analytical study on jackfruit seed flour and its incorporation in pasta. *Res. J. Pharm. Bio Chem. Sci.*, 5(2): 1597-1610.
2. Airani, S., 2007, Nutritional quality and value addition to jackfruit seed flour. M. H. Sc. Thesis, Univ. Agric. Sci., Dharwad (India).
3. Akubor, P. I. and Obiegbuna, J. E., 2014, Effect of processing methods on the quality of flour and bread from African breadfruit kernel flour. *Food Sci. Qua. Mgt.*, 24: 32-42.
4. Anonymous, 2000, Official Methods of Analysis of Association of Official Analytical Chemists, 20th Edition AOAC, Washington. D. C.
5. Azeez, S. O., Lasekan, O., Jinap, S. and Sulaiman, R., 2015, Physico-chemical properties, amino acid profile and antinutritional factors in seeds of three Malaysian grown jackfruit cultivars. *J. Food. Agric. Envr.*, 13(2): 58-62.
6. Butool, S and Butool, M., 2013, Nutritional quality on value addition to jackfruit seed flour. *Intr. J. Sci. Res.*, 4(4): 2406-2411.
7. Dakare, M. A., Ameh, D. A., Agbaji, A. S. and Atawodi, S. E., 2014, Chemical composition and antinutrient contents of yellow maize, raw and processed composite mango (*Mangifera indica*) seed kernel from Zaria, Nigeria. *Inter. J. Adv. Res.*, 2(7): 90-97.
8. Ejiogor, J. E., Beleya, E. A. and Onyenorah, N. I., 2014, The effect of processing methods on the functional and compositional properties of jackfruit seed flour. *Intr. J Nutr. Food Sci.*, 3(3): 166-173.
9. Hettiaratchi, U. P. K., Ekanayake, S. and Welihinda, J., 2011. Nutritional assessment of jackfruit (*Artocarpus heterophyllus*) meal. *Ceylon Med. J.*, 56: 54-58.
10. Ijeh, I. I., Ejike, E. C. C., Nkwonta, O. M. and Njoku, B. C., 2010, Effect of traditional processing techniques on the nutritional and phytochemical composition of African bread fruit (*Treulia africana*) seeds. *J. Appl. Sci. Envr. Mgt.*, 4: 169-173.
11. Islam, M. S., Begum, R., Khatun, M., Dey, K. C., 2015, A study on nutritional and functional properties analysis of jackfruit seed flour and value addition to biscuits. *Intr. J. Eng. Res. Tech.*, 4(12): 139-147.
12. Kaushik, N., Kumar, K. and Roy, S., 2007. Genetic variability and divergence studies in seed traits and oil content of *Jatropha (Jatropha curcas)* accessions. *J. Biomass. Bioenergy.*, 31: 497-502.



13. Khattak, A. B., Bibi, N. and Aurangzeb., 2007, *Quality assessment studies of mung bean genotypes. American J. Food Tech.*, 2 (1): 536 – 542.
14. Naik, R. K., 1991, *Studies on storage of Ber fruit. M. Sc. Thesis, Univ. Agric. Sci., Dharwad (India).*
15. Okafor, O. E., Ezeanyika, L. U. S., Ujowundu, C. U. O., 2015, *Effect of traditional processing techniques on the proximate and mineral composition of jackfruit (Artocarpus heterophyllus) seeds. Intr. Conf. Food Sci. Chem. Envir. Engg. Kuala Lumpur, August 25-26. pp. 1-4.*
16. Ramulu, P. and Roa, U. P., 1997, *Effect of processing on dietary fiber content of cereals and pulses. Plants Human Nutri*, 50: 249-257.

APPENDIX

Table 1 Physical quality characteristics of jackfruit seeds

Parameters	Mean ± S.D
Colour	Brown
Shape	Oval
Weight (g)	5.47 ± 0.76
Volume (ml)	5.25 ± 0.32
Bulk density (g/ml)	1.06 ± 0.05
Length (cm)	3.52 ± 0.18
Width (cm)	1.77 ± 0.15
Length : Width	2.00 ± 0.21
Thickness (cm)	1.27 ± 0.12

Note: Average of 10 seeds

**Table 2 Effect of processing on proximate composition of jackfruit seed flour**

Treatment	Proximate composition (%)							
	Moisture	Protein	Fat	Crude Fibre	Ash	Carbohydrate		Energy (Kcal)
						Total	Available	
Unprocessed	10.26 ± 0.23 ^c	11.68 ± 0.34 ^e	1.15 ± 0.05 ^a	3.66 ± 0.03 ^d	3.61 ± 0.02 ^a	68.57 ± 0.51 ^a	72.30 ± 0.53 ^a	331 ± 3.00 ^{bc}
Boiling	11.42 ± 0.14 ^b	12.74 ± 0.16 ^d	1.04 ± 0.05 ^b	3.84 ± 0.05 ^b	3.27 ± 0.12 ^b	67.59 ± 0.26 ^b	71.43 ± 0.22 ^b	332 ± 3.00 ^{bc}
Pressure cooking	11.84 ± 0.03 ^a	13.17 ± 0.04 ^c	1.03 ± 0.03 ^b	3.96 ± 0.01 ^a	2.93 ± 0.04 ^c	67.56 ± 0.31 ^b	71.03 ± 0.07 ^b	330 ± 3.00 ^c
Pan roasting	9.72 ± 0.03 ^d	14.21 ± 0.20 ^a	1.14 ± 0.08 ^a	3.80 ± 0.01 ^b	3.67 ± 0.12 ^a	67.82 ± 0.24 ^b	71.36 ± 0.31 ^b	336 ± 3.00 ^{ab}
Microwave roasting	9.66 ± 0.08 ^d	13.71 ± 0.16 ^b	1.16 ± 0.03 ^a	3.83 ± 0.03 ^b	3.84 ± 0.11 ^a	67.80 ± 0.32 ^b	71.62 ± 0.30 ^b	337 ± 4.00 ^a
Baking	9.17 ± 0.19 ^e	14.42 ± 0.23 ^a	1.21 ± 0.03 ^a	3.73 ± 0.03 ^c	3.67 ± 0.36 ^a	67.86 ± 0.44 ^b	71.52 ± 0.41 ^b	340 ± 4.00 ^a
F value	199.25	71.75	8.10	35.32	11.98	5.99	4.65	4.09
S. Em. ±	0.16	0.24	0.05	0.04	0.19	0.40	0.39	3.89
C. D. at 5%	0.25*	0.37*	0.08*	0.06*	0.30*	0.62*	0.60*	5.99*

*Significant at 5 % level



RELATIONSHIP BETWEEN EXCHANGE RATE AND SECURITIES' MARKET RETURNS: EVIDENCE FROM COMPANIES LISTED AT NAIROBI SECURITIES EXCHANGE

Tonui Hillary Kipkemoi

MBA Student, University of Kabianga

Dr. Isaac Naibei

Senior Lecturer, Department of Accounting and Finance, University of Kabianga

Dr. Joseph Kiprono Kirui

Senior Lecturer, Department of Marketing, Management Science, Tourism and Hospitality Management, University of Kabianga

ABSTRACT

There are a few studies with reference to companies listed at Nairobi Securities Exchange on relationship between selected macroeconomic factors and securities' market returns. This study seeks to investigate the relationship between selected macroeconomic factors and securities, market returns: Evidence from companies listed at Nairobi Securities Exchange. The study was guided by the following objective; to analyze the relationship between exchange rate and securities' market returns at Nairobi securities Exchange. This study used the following Modern Portfolio Theory (MPT). The research adopted a cross sectional design. Out of the 61 firms listed at the Nairobi Securities Exchange, data for 46 firms were obtained for the entire study period. One data collection instrument called data extraction form was used in collecting data for this study. Validity on the relationship between selected macroeconomic factors and securities' market returns at the Nairobi securities exchange was done by analysing secondary data from the Nairobi securities exchange and central bank of Kenya. Test-retest method and Parallel/Equivalent forms of the same test were used to establish reliability of measuring instrument. The findings of the study showed that interest rate plays an important role in influencing the changes or variations of the securities' market returns in Kenya albeit the fact that the study results in some sector stock Performance indicated that interest rate has insignificant influence on the direction of the stock market performance. The study concluded that the contribution of exchange rate on the securities' market returns in Kenya was found critical due to its significant influence on the securities' market returns.

BACKGROUND OF THE STUDY

Nairobi securities exchange has over six decade's heritage in listing equity and debt securities. It offers a world class trading facility for local and international investors looking to gain exposure to Kenya and Africa's economic growth. Nairobi securities exchange plays a vital role in the growth of

Kenya's economy by encouraging savings and investment, as well as helping local and international companies' access cost-effective capital. Nairobi securities exchange operates under the jurisdiction of the Capital Markets Authority of Kenya. It is an affiliate of the World Federation of Exchange, a founder member of the African Securities Exchanges



Association (ASEA) and the East African Securities Exchanges Association (EASEA). The Nairobi securities exchange is a member of the Association of Futures Market and is a partner exchange in the United Nations-led SSE initiative (Agrawal, 2010).

The Nairobi securities exchange provides integrated report which aims to enable its stakeholders, including investors, to make highly informed assessment of the Nairobi securities exchange and its forecasts. The Nairobi securities exchange always make a deliberate choice to communicate its company's story through an integrated report as it appreciate its traditional standards for measuring value and financial growth no longer provide a comprehensive true picture of the company. Therefore Nairobi securities exchange believes that entrenching such practices in its business will help to drive improved governance practices through more inclusive identification and management of current and future opportunities and risks (Asprem, 2011).

Nairobi securities exchange uses an integrated approach to determine its financial and sustainable performance. It always look for ways of working with its stakeholders to create lasting value, while continuing its journey to deliver on its vision, To be a leading securities exchange in Africa with a global reach. The Nairobi securities exchange is a key area of measuring the performance of a given sector of the economy since the securities market remains very sensitive to various factors which will be clearly discussed here (Babak, 2012).

STATEMENT OF THE PROBLEM

There are a few studies with reference to companies listed at Nairobi Securities Exchange on relationship between selected macroeconomic factors and securities' market returns. For example, Songole (2012) focused on the relationship between selected macroeconomic variables and stock return at the Nairobi Securities Exchange. Mwangi, Makau & Kosimbei (2014) examined the relationship between capital structure and performance of non-financial companies listed in the Nairobi Securities Exchange, Kenya. Finally, Karubari, N. T. (2017) focused on the effect of selected macro-economic variables on stock market depth at the Nairobi Securities Exchange. However, these studies provide no information on the relationship between selected macroeconomic factors and securities' market returns evident from companies listed at Nairobi Securities Exchange. In this context, the objective of the current study is to analyze the relationship between exchange rate and securities' market returns at Nairobi Securities Exchange.

PURPOSE OF THE STUDY

The purpose of this study is to assess the

relationship between selected macroeconomic factors and securities' market returns from companies listed at Nairobi securities Exchange.

Specific Objective of the study

The objectives of this study are;

- i. To analyze the relationship between exchange rate and securities' market

LITERATURE REVIEW

Exchange rate

This is the rate at which one currency will be exchanged for another. It is also regarded as the value of one country's currency in relation to currency of another country. The spot exchange rate refers to the current exchange rate. The forward exchange rate refers to an exchange rate that is quoted and traded today but for delivery and payment on a specific future date. In the retail currency exchange market, different buying and selling rates will be quoted by money dealers. Most exchanges are based on the local currency. The buying rate is the rate at which money dealers will buy foreign currency, and the selling rate is the rate at which they will sell that currency. The quoted rates will incorporate an allowance for a dealer's margin (or profit) in trading, or else the margin may be recovered in the form of a commission or in some other way. Different rates may also be quoted for cash, a documentary form or electronically. The higher rate on documentary transactions has been justified as a compensation for the additional time and cost of clearing the document. On the other hand, cash is available for resale immediately, but brings security, storage, and transportation costs, and the cost of tying up capital in securities of banknotes (bills).

In the foreign exchange market, a currency pair is the quotation of the relative value of a currency unit against the unit of another currency. The quotation EUR/USD 1.3225 means that 1 Euro will buy 1.3225 US dollars. In other words, this is the price of a unit of Euro in US dollars. Here, EUR is called the "Fixed currency", while USD is called the "Variable currency" (Chen & Jordan, 2011).

Quotation using a country's home currency as the price currency is known as direct quotation or price quotation (from that country's perspective). For example, EUR 0.8989 = USD 1.00 in the Eurozone and is used in most countries. Quotation using a country's home currency as the unit currency, (for example, USD 1.11 = EUR 1.00 in the Eurozone) is known as indirect quotation or quantity quotation and is used in British newspapers; it is also common in Australia, New Zealand and the Eurozone. Using direct quotation, if the home currency is strengthening (that is, appreciating, or becoming more valuable) then the exchange rate number decreases. Conversely, if the foreign currency is



strengthening and the home currency is depreciating, the exchange rate number increases (Chittedi, 2011)

Factors affecting the change of exchange rate

1. Balance of payments. When a country has a large international balance of payments deficit or trade deficit, it means that its foreign exchange earnings are less than foreign exchange expenditures and its demand for foreign exchange exceeds its supply, so its foreign exchange rate rises, and its currency depreciates (Choi & Rajan, 2011).
2. Fiscal and monetary policy. Although the influence of monetary policy on the exchange rate changes of a country's government is indirect, it is also very important. In general, the huge fiscal revenue and expenditure deficit caused by expansionary fiscal and monetary policies and inflation will devalue the domestic currency. The tightening fiscal and monetary policies will reduce fiscal expenditures, stabilize the currency and increase the value of the domestic currency (Cooper, 2010).
3. Venture capital. If speculators expect a certain currency to appreciate, they will buy a large amount of that currency, which will cause the exchange rate of that currency to rise. Conversely, if speculators expect a certain currency to depreciate, they will sell off a large amount of the currency, resulting in speculation. The currency exchange rate immediately fell. Speculation is an important factor in the short-term fluctuations in the exchange rate of the foreign exchange market (Creswell & Clark, 2011).
4. Government market intervention. When exchange rate fluctuations in the foreign exchange market adversely affect a country's economy, trade, or the government needs to achieve certain policy goals through exchange rate adjustments, monetary authorities can participate in currency trading, buying or selling local or foreign currencies in large quantities in the market. The foreign exchange supply and demand has caused the exchange rate to change (Dhrymes, Friend & Gultekin, 2012).
5. Economic strength of a country. In general, high economic growth rates are not conducive to the local currency's performance in the foreign exchange market in the short term, but in the long run, they

strongly support the strong momentum of the local currency (Dickey & Fuller, 2009).

Modern Portfolio Theory (MPT)

This is a theory presented in 1952 out of an article and in 1959 out of a book by Harry Markowitz as essentially Portfolio Theory "in light of the fact that "there is nothing current about it. Since it was first presented there have been numerous augmentations. This is a hypothesis of reserve that undertakings to increase portfolio expected return for a given measure of portfolio risk level. Similarly constrain chance for a given level of expected return, by means of carefully picking the amounts of various assets. In spite of the way that it is comprehensively used as a piece of preparing in the money related business the basic assumptions of the speculation have been by and large tried by fields, for instance, social budgetary issues.

It is a numerical arrangement of widening in contributing, with the purpose of picking a social affair of hypothesis assets that has aggregately cut down risk than any individual asset. This is possible in light of the assumption that particular sorts of advantages as often as possible modify in a motivating force in opposite course. For instance, to the degree costs in the offer market move remarkably as opposed to costs in the security exhibit, a social affair of the two sorts of points of interest can on a fundamental level face cut down general danger than either autonomously. Regardless, expanding cuts down risks paying little attention to whether assets' benefits are not inconsistently related, most likely, paying little attention to whether they are firmly related.

All the same all the more really, MPT models the benefits of an advantage as a regularly distributed limit, delineates chance as the standard deviation of return, and models a portfolio as a weighted blend of preferences, so the landing of a portfolio is the weighted mix of the benefits of the points of interest. By consolidating distinctive resources whose profits are not very well decidedly connected, MPT broadens the aggregate difference of the portfolio return. Modern portfolio theory (MPT) also accepts that investors are sound and markets are efficient. This theory was created in the 1950s through the mid-1970s and it was viewed as a vital progress in the scientific displaying of finance. Since at that point, some hypothetical and functional reactions have been leveled against it.

These incorporate confirmation that money related returns don't take after a Gaussian appropriation or for sure any symmetric dissemination and connections between benefit classes which are not settled but rather can shift depending on outer events, for example, emergencies. Further, there remains affirmation that budgetary controllers are not ordinary and markets



may not be efficient. Finally the low eccentricity inconsistency conflicts with trade off assumption of higher risk for higher return of Capital Asset Pricing Model (CAPM). It communicates that a portfolio containing low risk returns, for instance, blue chip securities gets higher risk adjusted returns than a portfolio with high instability, for instance, illiquid securities.

A study carried out by Myron Scholes, Michael Jensen and Fischer Black in 1972 recommends that the association among return and beta might be level or even negatively related.

RESEARCH METHODOLOGY

Research Design

This study was based on a cross sectional design. This research design was founded on one period in time particularly the year 2019. According to Kothari (2010) a research design is the game-plan of conditions for social affair and analysis of data in a way that hopes to unite enormity to the research reason. It is the theoretical framework into which the entire research is conducted. It indicates the reasons behind a research, specifies the sources of information to be gathered, and distinguishes possible limitations that may influence the research (Saunders, 2010).

Target Population

According to Mugenda and mugenda (2008), the term target population is the complete set of individuals, cases, or objects with some characteristics to which the researcher wants to generalize the results of the study. The target population was exchange rate, inflation rate, interest rate, gross national income and coupon rate of government bonds in relation to securities market returns of 65 companies listed at the Nairobi securities exchange.

Sample and Sampling procedures

For the exchange rate, inflation rate, interest rates, Gross national income and coupon rate of government bonds in relation to securities' market returns. This will be done in relation to all 65 companies listed at Nairobi securities exchange. The monthly time series data for the 65 companies listed at NSE covering a period of one year will be used.

Data Collection instrument

The data was collected using data extraction form. The Month to month data rather than daily data were used to avoid duplication from some securities that most of the macroeconomic factors are fully considered in this research are released on a month to month period. In this process of extracting data from the Nairobi securities exchange.

Data collection procedures

Data extraction was done using data extraction forms. This was used to collect secondary data from central bank of Kenya (CBK), Nairobi securities exchange (NSE) and Kenya national bureau of statistics (KNBS). The main areas of interest as far as securities' market returns are concerned include exchange rate, interest rate, Gross national income and coupon rate of government bonds. The secondary data are readily available from the other sources and as such, the researcher can obtain data from sources both internal and external to the organization which includes; company information, public records from governmental agencies, research organizations and management information system. There are several external sources where secondary data were collected. These includes; government censuses, internet, where wide knowledge about different areas is available.

Data Analysis and Presentation

This is the stage at which the researcher begins to make deductions and inferences about data. It involves uncovering the underlying structures, extracting important variables, detecting any anomalies and testing any underlying assumptions (Kombo & Tromp, 2009). This enables the researcher to link theory with reality, that is, to test his/her research hypotheses and find answers to the study.

RESULTS AND DISCUSSION

Descriptive Analysis

The values for asymmetry and kurtosis between -2 and +2 are considered acceptable in order to prove normal univariate distribution (George & Mallery, 2010). In this case, it is observed that all variables of interest have an acceptable range of skewness, the highest being the coupon rate of government bonds at 1.272049, still under 2.

**Table 4.3: Kurtosis**

stats	securi~g	xrate	infrate	intrate	cpr	gni
mean	71.92335	101.3017	4.701667	9.333333	7.890833	8715250
max	80.09286	102.92	5.71	10	8.9	8970584
min	64.44089	100.61	3.73	9	7.34	8372820
range	15.65196	2.31	1.98	1	1.56	597764
sd	5.613767	.7895779	.7406979	.3892495	.3899757	230343.3
skewness	.0100067	.9797507	.3298306	.626099	1.272049	-.5187424
kurtosis	1.609616	2.527256	1.527137	2.04	4.939985	1.916709
p50	71.4867	101.04	4.43	9.25	7.915	8758797

As for kurtosis, three variables Exchange Rate, Interest Rate and Coupon Rate of Government Bonds fall outside the bounds of two (2). This indicates that the three variables are leptokurtic with peaks that are higher than normal.

Securities returns

The returns on invested securities had a mean of 71.92335 and a standard deviation of 5.6137 for the year 2018. Its lowest point was in November 2018 at 64.44089 million. The highest returns

were in March 2018 at 80.09286 most probably due to the improving political climate after the 2017 general elections. Overall, it was a steady decline in trend for the period under study.

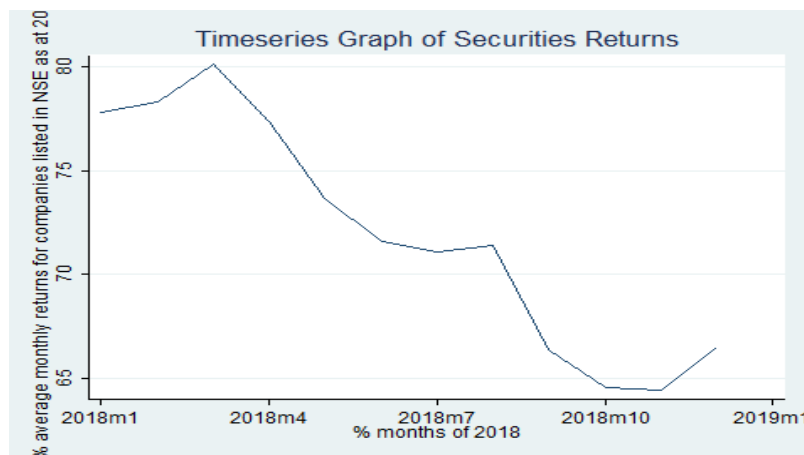
**Fig 4.2 Average Returns on Securities from Jan-Dec 2018**

Exchange rates

The exchange rate had a mean of 101.3017 and a standard deviation of 0.7896. It peaked in the January at 102.92 KES/USD most probably due to the weakening of the shilling against the dollar after the 2017 general elections and its subsequent unrest. What followed was a steady but marginal

strengthening of the Kenya Shilling until April, then somewhat plateaued all the way to August. April and August were the months with the lowest exchange rates at 100.61 KES/USD. This was followed by a steady rise to 102.36 KES/USD in November and the year ended with a rate of 102.29 KES/USD.

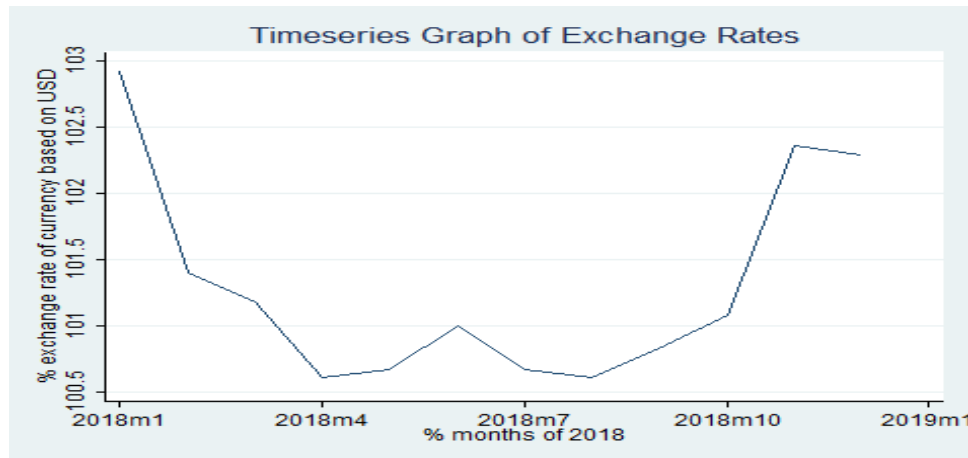

Fig 4.5 Exchange Rates (KES/USD) from Jan - Dec 2018.

```
. regress sec_manuf xrate infrate intrate gni cpr
```

Source	SS	df	MS	Number of obs =	12
Model	2419.35307	5	483.870615	F(5, 6) =	7.08
Residual	409.993101	6	68.3321835	Prob > F	= 0.0168
Total	2829.34617	11	257.213289	R-squared	= 0.8551
				Adj R-squared	= 0.7343
				Root MSE	= 8.2663

sec_manuf	Coef.	Std. Err.	t	P> t	[95% Conf. Interval]
xrate	7.563814	6.047209	1.25	0.258	-7.233173 22.3608
infrate	-15.751	6.355047	-2.48	0.048	-31.30124 -.2007595
intrate	22.41252	10.10768	2.22	0.068	-2.320069 47.14511
gni	-.0000188	.0000201	-0.94	0.385	-.0000679 .0000303
cpr	-5.833867	7.129793	-0.82	0.444	-23.27984 11.61211
_cons	-556.2235	634.857	-0.88	0.415	-2109.663 997.2156

Exchange Rate and Performance of Securities at the NSE

The study sought to test hypotheses at 5% level of significance for each of the five macroeconomic variables of interest. Their individual effect on the performance of securities

invested at the NSE was checked and the following hypotheses tested,

H01: There is no significant relationship between exchange rate and securities' market returns



Source	SS	df	MS	Number of obs = 12		
Model	2.02262978	1	2.02262978	F(1, 10) =	0.06	
Residual	344.635513	10	34.4635513	Prob > F =	0.8135	
Total	346.658143	11	31.5143766	R-squared =	0.0058	
				Adj R-squared =	-0.0936	
				Root MSE =	5.8706	

securities~g	Coef.	Std. Err.	t	P> t	[95% Conf. Interval]	
xrate	-.5430838	2.241758	-0.24	0.813	-5.538031	4.451864
_cons	126.9386	227.1001	0.56	0.588	-379.0719	632.9492

The exchange rate alone only explains 0.58% of the variability in securities and appears to be a very weak predictor. The P-value for exchange rate at 0.8135 is much bigger than the significance level of 0.05. This means that the variability in the performance of securities could be because of factors other than exchange rate. We therefore fail to reject the null hypothesis at 0.05 level of significance and conclude that there is no significant relationship between exchange rate and securities' market returns.

CONCLUSIONS AND RECOMMENDATIONS

Exchange Rate and Securities' Market Returns

The findings on the first study objective on whether exchange rate has an effect on the Securities' Market Returns on various firms listed in Nairobi Securities Exchange in Kenya had varied findings dependent on the nature of sector under consideration. Specifically, the study findings revealed that exchange rate plays an important role in influencing the changes or variations of the Securities' Market Returns in Kenya albeit the fact that the study results in the various sectors market returns indicated that exchange rate has insignificant influence on the direction of the stock market performance.

Conclusions

Based on the findings, this study concludes the following;

The contribution of exchange rate on the securities' market returns in Kenya was found critical due to its significant influence on the securities' market returns. Kenya as country experiences challenges in management of exchange rates owing to being a net importer with most of the imports being oil and machinery. Over the years, the shilling has been unstable against the hard currencies of the world implying that even the foreign debts denominated in forex end up becoming a great

burden on Kenyan economy. Terrorism attacks in Kenya and heightening level of insecurity has against affected number of tourists arrivals in Kenya due to insecurity challenges. Glut in the tea export markets have also seen Kenya receiving poor tea payments while tea is the major export earner of Kenya. All these factors among other have left the value of Kenya shilling eroded. Currency devaluation has resulted to balance of payment problems challenges for a long time in Kenya to the extent that most of the companies in Kenya suffer financial losses due to the cost of imports. Due to the great role played by exchange rate in an economy in influencing the performance of companies, the management of these companies needs to institute great measures to cushion themselves against forex losses. Such measures may include borrowing foreign denominated loans, employing hedging strategies to cushion themselves from future losses e.g. use of derivatives, setting subsidiaries in stable currency countries as well as close monitoring of movements of shilling against the major world currencies.

Recommendations

The study recommends the following based on the findings;

The Government of Kenya need to constantly review the macroeconomic policies to ensure the country is always cushioned against the external shocks like the credit crunch as well as oil crisis. To afford this, national policies as well as regulatory frameworks governing key sectoral reforms with large external dependencies need to be instituted like the imports of oil and machinery and foreign debts and loans. Such drivers on oil exploration, minerals and food security will go a long way in ensuring the shilling remain stable, inflation is tamed, interest rates do not sky rocket while money supply is controlled by use of domestic instruments to stabilize inflation and interest rates. All brokerage firms and investment advisors need to conduct periodic research on macroeconomic environment and advise their clients accordingly on the best counters to invest



in owing to the various influences by macroeconomic environment on the stock market performance. On findings of macroeconomic trends, the investment advisors and brokerage firms need to seek redress from the relevant policy makers as well as institutions aimed at bringing stability for the well good of the stock investors.

REFERENCES

1. Agrawal, G. (2010). A Study of Exchange Rates Movement and Securities Market Volatility. *Journal of security market returns*, 5(12), 62–73.
2. Bandiera, L., Kumar, P., & Pinto, B. (2012) Kenya's Quest for Growth Stabilization and Reforms—But Political Stability? *World Bank Policy Research Working Papers*, 8, 224-226
3. Banny, A., & Enlaw, S. H. (2011). The Relationship between Securities Price and Exchange Rate: Empirical Evidence Based on the KLSE Market. *Asian Economic Review*, 42, 39-49.
4. Belle G.V., (2011). *Statistical rules of thumb*. (2nd ed.) Hoboken, NJ: Wiley
5. Brooks, C. (2008). *Introductory econometrics for finance*. Cambridge, NY: Cambridge University Press.
6. Brunner, K. (2010) Some Major Problems in Monetary Theory. *American Economic Review*, 6,47-56.
7. Chittedi, K. R. (2011) Integration of International Stock Markets: With Special Reference to India. *GITAM Journal of Management*, 9, 3-5.
8. Choi, J. J., & Rajan, M., (2011). A joint test of market segmentation and exchange risk factor in international capital markets. *Journal of International Business Studies* 28, 29–49.
9. Cooper, R. (2010). Efficient capital markets and the quantity theory of money. *Journal of Finance*, 29(3), 887-908.
10. Creswell, J. W. & Clark, V. L. (2011). *Designing and Conducting Mixed Methods Research*. Thousand Oaks, CA: Sage Publications.
11. Dhrymes, P. J., Friend, I. & Gultekin, B. N. (2012). A critical re-examination of the empirical evidence on the Arbitrage Pricing Theory. *The Journal of Finance*, 39(2), 323–346.
12. Dickey, D.A. & W.A. Fuller. (2009). *Likelihood Ratio Statistics for Autoregressive*
13. Dumas, B. (1978). The theory of the trading firm revisited. *Journal of Finance*, 33(3),
14. Erb, C., Harvey, C. & Viskanta, T. (2011). Country risk and global equity selection. *The Journal of Portfolio Management*, 21(2), 74–83.
15. Fama, E. (2010). The Behaviour of Security Market Prices. *Journal of Business*, 38, 34 -105.
16. Fama, E. (2010). Securities market Returns, Expected Returns And Real Activity. *Journal of Finance*, 25,(2)1098-1108.
17. Fama, E. (2010). Security returns, real activity, inflation and money. *American*
18. Madura, J. (2012) *Financial Markets and Institutions*. (3rd ed.). London. West Publishing Company.
19. Mugenda, & Mugenda, A.G. (2012). *Research Methods Quantities and Qualitative Approaches*, Nairobi. Acts Press Publishers.
20. Mwangi, L. W., Makau, M. S., & Kosimbei, G. (2014). Relationship between capital structure and performance of non-financial companies listed in the Nairobi Securities Exchange, Kenya. *Global Journal of Contemporary Research in Accounting, Auditing and Business Ethics*, 1(2), 72-90.
21. Patterson, K (2012). *An Introduction to Applied Econometrics*. NY. St. Martin's Press
22. Watsham, T. J. & Parramore, K. (2011). *Quantitative methods in Finance*". (1st ed.).
23. Zhou, C. (2010). *Securities Market Fluctuations and the Term Structure*. Board of Governors of the Federal Reserve System, Finance and Economics Discussion Series:96/03



A STUDY ON CONSUMER SATISFACTION TOWARDS AIRTEL WITH REFERENCE TO COIMBATORE CITY

Venkateshwara.V.S

*Student of III B.Com.(PA), Department of Commerce with Professional Accounting
Dr. N. G. P Arts and Science College Coimbatore.*

Mr .A.David

*Assistant Professor,Department of Commerce with Professional Accounting,
Dr. N. G. P Arts and Science College, Coimbatore.*

ABSTRACT

The project entitled "A study on customer satisfaction towards Airtel in Coimbatore city " is carried out with an objective to determine the consumer preference and satisfaction. A descriptive study was conducted to achieve the objectives. In total 100 respondents filled a well-structured questionnaire having a list of statements pertaining to products, services & facilities provided by the service provider. The main objective of the study was to know how the customers of AIRTEL Broadband perceive its Services in Coimbatore are satisfied with the services provided by AIRTEL and also to identify the factors affecting the preferences of the customers Results reveal that the dimensions which influence the satisfaction level of customer's are: Core services (like good coverage, good connectivity and network quality) and call rate. Further results show that there is a significant relation between the brand name and the preference of customers. Hence, it has been recommended that telecom companies should focus on connectivity, call rate, coverage and network quality.

KEYWORDS Airtel, Comparative study, Customer satisfaction, Mobile connection.

INTRODUCTION

Telecommunication companies also talk of their customer being most important asset, us like companies in other business domains but rarely are this reflected in a company's strategy and operations. The customer of telecom services like cellular telephony are ahead with times and have started buying cellular services just like daily house hold items such as toothpaste. Therefore it is necessary in today's business scenario to understand the fact that the idea of customer being ac company's most important assets is not just a management theory, but is a crucial economic fact in the current business scenario the use of customer relationship management (CRM) is quite common and critical and customer retention is the primary goal in

firms that practices. In the light of the important of customer relationship and consumer retention, it is very crucial for the companies in any business domain to know what actually drives the customer satisfaction. As the cellular industry in India is one of the fastest growing sectors it is important and interesting to explore the drives of customer satisfaction in the industry.

STATEMENT OF THE PROBLEM

In this modern era, everyone is using mobile. Without mobile phone nobody can lead their life. Hence in this study it is focused on the usage level of AIRTEL mobile services and how it is useful to know about the preference of brand and also how to identify



the satisfaction level of the customers by the usage of AIRTEL mobile services.

SCOPE OF THE STUDY

The present research analysis is a wide scope. It covers various aspects which are useful in several ways to various people.

- It helps to find out the leading cellular service provides in Coimbatore city at present.
- It show the various for selecting the particular cellular service.

OBJECTIVES OF THE STUDY

- To study on consumer behavior on Airtel in Coimbatore city .
- To study the problems faced by the Customers.

TOOLS FOR ANALYSIS

The primary data were coded, classified, tabulated and analysed. The statistical tools used for analysis of the study are:

- Simple percentage Analysis
- Ranking Correlation
- Likert scale Analysis

LIMITATION OF THE STUDY

- This study is restricted to Coimbatore city only due to cost and time constraints.
- The information provided by the respondents is spontaneous and they may not be consistent.

REVIEW OF LITERATURE

Dinesh Kumar Pandiya et al., (2014), found that the customer satisfaction lies in GPRS service, festival offer service, free roaming service, validity service, bonus service and online recharge service whereas they dissatisfied with the service quality of network, customer care, SMS packs, free talk time, connection charges, Ease of availability of the retailer selling recharge coupons, Ease of availability of retailers transferring the recharge voucher.

Buveneswari and R. PrakashBabu67 (2013) in their article entitled, “Study on Customer

Satisfaction towards Cellular Service with Special Reference to Aircel at Mannargudi Town” have found that telecommunications companies also talk of their customers being their most important assets like companies in other business domains. Aircel cellular service in Mannargudi Town the subscription by the people is satisfactory and is steadily increasing. The company has wider scope in the market of cellular service by extending its value added services, according to preference of the respondents.

Rajpurohit and Vasita (2011), examined the consumer preferences and satisfaction towards various mobile phone service providers in Jodhpur city and found that Airtel, Vodafone, MTNL, Idea, Tata Indicom subscribers are satisfied with the call tariffs, network coverage and periodical offers, customer complaints handling and solutions except the customers who subscribed BSNL and Reliance networks.

DATA ANALYSIS AND INTERPRETATION

In this chapter the analysis and interpretation of “A study on customer’s satisfaction towards Airtel with special reference to Coimbatore city”, is presented based on the opinion of samples of 120 respondents selected from Coimbatore city through a questionnaire containing 20 questions. These were analysed through three different tools and they are as follows,

- Simple Percentage analysis
- Rank Correlation
- Likert scale analysis

SIMPLE PERCENTAGE ANALYSIS:

Simple percentage analysis is the method to represent raw streams of data as a percentage for better understanding of collected data. Percentage analysis is applied to create a contingency table from the frequency distribution and represent the collected data for better understanding.

FORMULA:

$$\text{Percentage} = \frac{\text{Number of respondents}}{\text{Total no. of respondents}} \times 100$$

TABLE 1

TABLE SHOWING THE GENDER OF THE RESPONDENTS

S. NO.	GENDER	NO. OF RESPONDENTS	PERCENTAGE
1	Male	37	46
2	Female	43	54
	TOTAL	80	100

(Source: Primary data)



INTERPRETATION

Majority, 54% of the respondents are female.

The above table shows that out of total 80 respondents, 54% of the respondents are female and 46% of the respondents are male.

TABLE 2
TABLE SHOWING THE EDUCATIONAL QUALIFICATION OF THE RESPONDENTS

S. NO.	EDUCATIONAL QUALIFICATION	NO. OF RESPONDENTS	PERCENTAGE
1	School level	8	10
2	Diploma	8	10
3	Under Graduate	48	60
4	Post graduate	16	20
	TOTAL	80	100

(Source: Primary data)

INTERPRETATION

10% of the respondents are upto school level and diploma.

The above table shows that out of total 80 respondents, 60% of the respondents are under graduate, 20% of the respondents are post graduate,

Majority, 60% of the respondents are under graduate.

TABLE 3
TABLE SHOWING THE OCCUPATIONAL STATUS OF THE RESPONDENTS

S. NO.	OCCUPATION	NO. OF RESPONDENTS	PERCENTAGE
1	Student	33	41
2	Government Employee	13	16
3	Private employee	22	28
4	Self employed	12	15
	TOTAL	80	100

(Source: Primary data)

INTERPRETATION

respondents are government employee, 15% of the respondents are self employed.

The above table shows that out of total 80 respondents, 41% of the respondents are students, 28% of the respondents are private employee, 16% of the

Majority, 41% of the respondents are students.

RANK CORRELATION

A rank analysis is any of several statistics that measure an ordinal association, the relationship between ranking of different ordinal variables or different ranking of the same variables, where a "ranking" is the assignment of the labels "first", "second", "third", etc., To different observation of a

particular variable. A rank analysis measures of similarity between two rankings, and can be used to assess the significance of the relation between them. It is not necessarily a total order of object because two different objects can have the same ranking. The ranking themselves are totally ordered.

**TABLE 4**
TABLE SHOWING THE PREFERENCE LEVEL OF RESPONDENTS TOWARDS AIRTEL

S. No.	Factors	Rank 1	Rank 2	Rank 3	Rank 4	Rank 5	Total	Rank
1	Customer Services	59(5)	9(4)	7(3)	4(2)	1(1)	361	1
2	Internet Speed	7(5)	9(4)	56(3)	4(2)	4(1)	251	2
3	Network coverage	6(5)	9(4)	5(3)	58(2)	2(1)	199	3
4	Price	8(5)	8(4)	5(3)	7(2)	52(1)	153	5
5	Offers	5(5)	8(4)	10(3)	52(2)	5(1)	196	4

*(Source: Primary data)***INTERPRETATION**

The above table shows that out of total 80 respondents, Customer services has ranked 1st, Internet Speed has ranked 2nd, Network coverage has ranked 3rd, Offers has ranked 4th, Price has ranked 5th.

Majority, Respondents are satisfied with the Customer services in Airtel network.

LIKERT SCALE ANALYSIS:

Likert scales are the most broadly used method for scaling responses in research studies. Research questions that ask you to indicate your level of agreement, from strongly agree or highly satisfied to strongly disagree or highly dissatisfied, use the likert

scale. In Likert scale method, a person's attitude is measured by combining (additional or averaging) their responses across all items.

FORMULA: $\sum fx$ Likert scale = $\frac{\sum fx}{\text{Total number of respondents}}$

Where,

F = Number of respondents

X = Likert scale value

 $\sum fx$ = Total score**Mid value,**

Mid-value indicates the middle most value of the Likert scale.

TABLE 5
TABLE SHOWING THE SATISFACTION LEVEL OF RESPONDENTS TOWARDS AIRTEL NETWORK

S. NO.	SATISFACTION LEVEL	NO. OF RESPONDENTS (F)	LIKERT VALUE (X)	TOTAL (FX)
1	Highly Satisfied	56	5	280
2	Satisfied	12	4	48
3	Neutral	8	3	24
4	Dissatisfied	4	2	8
5	Highly dissatisfied	-	1	0
	TOTAL	80		360

(Source: Primary data)

$$\begin{aligned} \text{Likert value} &= \sum fx / \text{No. of Respondents} \\ &= 360 / 80 \\ &= 4.5 \end{aligned}$$

INTERPRETATION

Likert scale value is 4.5 which is greater than the mid value (3), so the respondent are satisfied with the airtel network.



TABLE 6

TABLE SHOWING THE LEVEL OF OPINION TOWARDS INTERNET SPEED FROM YOUR AIRTEL SERVICES

S. NO.	SATISFACTION LEVEL	NO. OF RESPONDENTS (F)	LIKERT VALUE (X)	TOTAL (FX)
1	Highly satisfied	6	5	30
2	Satisfied	63	4	252
3	Neutral	8	3	24
4	Dissatisfied	2	2	4
5	Highly dissatisfied	1	1	1
	TOTAL	80		311

(Source: Primary data)

$$\begin{aligned} \text{Likert value} &= \sum fx / \text{No. of Respondents} \\ &= 311 / 80 \\ &= 3.88 \end{aligned}$$

INTERPRETATION

Likert scale value is 3.88 which is greater than the mid value (3), so the respondents are satisfied with the internet speed provided by the Airtel Network .

- 94% of the respondents will suggest airtel network to others.
- 64% of the respondents Highly agree that Airtel network services are best in the market..

FINDINGS, SUGGESTIONS AND CONCLUSION**FINDINGS**

- 49% of the respondents are of between the age 15 years – 25 years.
- 54% of the respondents are female.
- 55% of the respondents are single
- 60% of the respondents are under graduate.
- 41.3% of the respondents are students.
- 32% of the respondent's family are earning Rs.10,001 – Rs.20,000.
- 55% of the respondents are using postpaid sim.
- 38% of the respondents have chosen clear signal which is more useful for consumers.
- 73% of the respondents are using Airtel Network for 1-5 years.
- 82% of the respondents can activate the sim within an hour.
- 97% of the respondents are satisfied with the customer service provided by airtel.

RANK ANALYSIS

- Respondents are satisfied with the Customer services in Airtel network..

LIKERT SCALE

- Likert scale value is 4.5 which is greater than the mid value (3), so the respondent are satisfied with the airtel network.
- Likert scale value is 4.58 which is greater than the mid value (3), so the respondents are satisfied with the price provided by the Airtel Network .
- Likert scale value is 3.88 which is greater than the mid value (3), so the respondents are satisfied with the internet speed provided by the Airtel Network .
- Likert scale value is 3.36 which is greater than the mid value (3), so the respondents are satisfied with the service provided by the Airtel Network .
- Likert scale value is 2.72 which is lesser than the mid value (3), so the respondents are not



satisfied with the signal provided by the Airtel Network .

- Likert scale value is 2.11 which is lesser than the mid value (3), so the respondents are not satisfied with the schemes provided by the Airtel Network .

SUGGESTIONS

- Airtel mobile company has to improve the awareness of its schemes provided. Various promotional schemes should be introduced by Airtel mobile companies to increase mobile phone sales.
- Company should give more support to stock more mobile phones and develop the Airtel mobile business. Youngsters are those who prefer new models and change their mobile frequently in order to cope with the fashion.
- Most of the respondents considered the network coverage as the main factor. So the mobile service provider must take necessary steps to promote and maintain the network coverage and in mean time the other factors and additional features are also given more priority by the mobile service providers to retain and earn new customers.

CONCLUSION

From the study on this report it is seen that launch of Airtel cellular service in Coimbatore city the subscription by the people is satisfactory and steady increasing. Majority of subscribers have expressed better service provided by Airtel cellular service but the

service by the franchisee is average. The sales executives should be motivated to improve the service and get tough with the respondents. The rate of income respondents is lower than the rate of outgoing respondents. The company should take several steps to eliminate the default which results in loss of respondents. The company has wider scope in the market of cellular service by extending its value added services, according to the preference of the respondents. The market in Coimbatore is still in an expending phase. It has been also observed the Airtel can gain more number of customers by widening its area of coverage. From this study of them given the conclusion the price is low service is best so we likely to by Airtel connection.

REFERENCE

1. Dinesh Kumar Pandiya et al., (2014), "A study on the impact of customer satisfaction on airtel". *International Conference on Advancements in computing and Management Volume, pp.no.1-8.*
2. Buvaneswari and R. PrakashBabu67 (2013) "Study on Customer Satisfaction towards Cellular Service with Special Reference to Airtel at Mannargudi Town". *International journal of Management Technology and Engineering.*
3. Rajpurohit and Vasita (2011) "The consumer preferences and satisfaction towards various mobile phone service providers in Jodhpur city", *Journal of Social and Administrative sciences, Volume 5 Issue 3.*



A STUDY ON CUSTOMER SATISFACTION IN RED -MI MOBILE WITH SPECIAL REFERENCE IN COIMBATORE CITY

Mr. S.Muruganantham

*Assistant Professor, Department of Commerce with Professional Accounting,
Dr. N. G. P Arts & Science College, Coimbatore.*

Miss.Nandhini Senthilkumar

*Student of III B.Com (PA), Department of Commerce with Professional Accounting,
Dr. N. G. P Arts & Science College, Coimbatore.*

ABSTRACT

This study concluded that in this modern business economy it is very important to analyse the marketing strategy used in the Red - mi mobile phones. The study result shows the majority of the consumers are satisfied with the Red - mi mobile phones but also there is a drawback such as hike in price and such other factor like design of the product. If necessary steps to re-solve problems of retaining customers of Red - mi mobile phone will be high. It will develop the strategy of marketing, if the company can understand the preference and overall perception of the consumer. Hence, it will develop the marketing strategy and market share of Red - mi mobile phone Company.

KEYWORDS: *Customer Satisfaction, Marketing strategy, modern business economy, analyses.*

INTRODUCTION

Marketing is the process of determining consumer demand for a product or service motivates its sales and distributing it to ultimate consumers at a profit. "Consumer is the central point of any business and all marketing activities revolve around him. It is essentially the satisfaction of customer needs through integrated marketing with the intent to satisfy the customer while earning profit. Mobile phone has become an integral part of human daily and personal communication across the globe. Mobile phones plays a predominant role in the modern life because mobile phones are used by people at all levels. Now a days everyone have got used to mobile phone so much and without mobile phones we feel so handicapped. During the introduction stages, mobile phones were used slowly for communication with technological innovations, advancements and convergence of feature of other industries, the functionality of the product has gone beyond imagination.

STATEMENT OF THE PROBLEM

The study identifies mobile phones as now become the basic need of every person in life. Red-mi plays the major role in mobile phone. Everyone prefer the Xiaomi mobile brands in now a days. Understanding of brand preference is essential aspects as it reflect the customer Choice, Purchase of particular brand, Preference, Style, Specification and Satisfaction of the customer. Along with the smart phones fundamental capabilities to make Voice call, Video call, SMS, MMS, Etc., This research find out present customer satisfaction on Red-mi smart phone and the market factors influencing the customer buying behaviour towards smart phones.

SCOPE OF THE STUDY

This study is conducted to know about the customer satisfaction in preference of the Red-mi mobile with special reference to Coimbatore city. It also reveals how to know, who the customers are, what they want, how they use their mobile and that was carefully studied by conducting survey on customer satisfaction. This study will helps to gain



knowledge about the marketing factors, influencing the customers to prefer a particular brand and problems faced by on using such brands and so on. It will be useful for company to make necessary changes in Price, Design, Apps and etc.

OBJECTIVE OF THE STUDY

- To know the social economics status of respondents.
- To identify the factors influenced to buying the Red-mi smart phone.
- To find out the reason why they are buying Red-mi mobile.

RESEARCH METHODOLOGY

A Research methodology or involves specific techniques that are adopted on research process to collect, assemble and evaluate data. It defines these tools that are used to gather relevant information in a specific in a research study.

- Source of data : Primary data and Secondary data.
- Sampling method : convenient sampling.
- Sampling size : 120 respondents.
- Area of the study : Coimbatore city.
- Analytical tools : Percentage analysis and Simple Rank method.

LIMITATIONS OF THE STUDY

The main limitation of studies are;

- This study was conducted in Coimbatore city.
- The data were collected from the 120 respondents.

REVIEW OF LITERATURE

N.Senthilkumar & K.Sabari Ram & K.Kumarvel (2019), explained today mobile technologies are rapidly developing and every five new models are launched by different companies. It identify the satisfaction level of customers, who uses Oppo mobile. In this study they used both primary data and secondary data as the source of research. Finally the researcher concluded that is no negatives from respondents towards Oppo mobiles and most of them are giving positive statement only.

Dr.R.Eswaran & M.Senthil (2016), point out that Nokia phones are loved by a lot of people and its name is synonymous with reliability. To evaluate the customer general buying behaviour of NOKIA mobile phones and understand the demographic profile of the sample respondents is Salem city. In this study they used primary data as the source of

research. This study has brought about certain unexplored trends regarding Nokia mobile phone is Salem city.

HISTORY AND PROFILE OF THE STUDY

Redmi is a sub-brand owned by the Chinese electronics company Xiaomi. It was first announced in July 2013 as a budget smartphone line, and became a separate sub-brand of Xiaomi in 2019 with entry-level and mid-range devices, while Xiaomi itself produces upper-range and flagship Mi phones. Redmi phones use the Xiaomi MIUI user interface on top of Android. Models are divided into Redmi (entry-level), Redmi

Note and Pro (mid-range), and Redmi A (low-end). In addition, the unrelated Mi a Android One series is also positioned in the similar market segment with Redmi devices, despite being part of the upper-range Xiaomi Mi lineup. The most significant difference from other Xiaomi smartphones is that they use less-expensive components and thus have lower prices while retaining higher specifications. In August 2014, The Wall Street Journal reported that in the second quarter of the 2014 fiscal year, Xiaomi had a market share of 14% of smartphone shipment rankings in China. Redmi sales were attributed as a contributing factor toward this gain in shipment rankings. In 2019, Redmi debuts its high-end series with the introduction of Redmi K models.

DATA ANALYSIS AND INTERPRETATION

In this chapter the analysis interpretation of the study on “ Consumer satisfaction towards Red-mi mobile phone “ is presented based on the opinion of sample of 120 respondents selected from Coimbatore city through a questionnaire containing 21 questions analyzed through

1. Simple percentage analysis
2. Simple Rank method

SIMPLE PERCENTAGE ANALYSIS

Simple percentage analysis is carried out for the all questions gives in questionnaire. This analysis describes the classification of the respondents failing each category. The percentage analysis is used mainly for the standardization and comparisons are support with the analysis



Formula,

$$\text{Percentage Analysis} = \frac{\text{No. of respondents}}{\text{Total no. of respondents}} * 100$$

TABLE NO. 1
TABLE SHOWING SIMPLE PERCENTAGE ANALYSIS

S.NO	GENDER	NO.OF RESPONDANTS	PERCENTAGE %
1	Male	41	34
2	Female	79	66
	TOTAL	120	100

Source: Primary data

INTERPRETATION

The above table shows that 34% of the respondents are male 66% of the respondents were female.

INFERENCE

Majority (66%) of the respondents were female.

SIMPLE RANKING METHOD

A Rank analysis is any of several statistics that measure an ordinal association, the relationship

between ranking of different ordinal variables or different ranking of the same variable, where a “Ranking” if the assignment of the labels “first”, “second”, “third”, etc., To different observation of a particular variable. A rank analysis measure of similarity between two rankings, and can be used to assess the significance of the relation between them. It is not necessarily a total order of objects can have the same ranking. The ranking themselves are totally ordered.

TABLE NO. 2
TABLE SHOWING SIMPLE RANKING METHOD

Source: Primary data

S.NO	FACTORS	RANK	RANK	RANK	RANK	RANK	RANK	RANK	RANK	RANK	RANK	TOTAL	RANK
		1	2	3	4	5	6	7	8	9	10		
1.	Battery	13 (10)	26 (9)	24 (8)	13 (7)	17 (6)	2 (5)	3 (4)	8 (3)	7 (2)	7 (1)	816	5
2.	Usage	9 (10)	19 (9)	40 (8)	14 (7)	10 (6)	5 (5)	3 (4)	8 (3)	2 (2)	10 (1)	814	6
3.	Style	14 (10)	18 (9)	28 (8)	25 (7)	6 (6)	4 (5)	7 (4)	5 (3)	6 (2)	7 (1)	819	4
4.	Access	10 (10)	29 (9)	23 (8)	23 (7)	8 (6)	6 (5)	2 (4)	7 (3)	3 (2)	9 (1)	828	2
5.	Camera	13 (10)	14 (9)	25 (8)	29 (7)	13 (6)	3 (5)	4 (4)	2 (3)	9 (2)	9 (1)	801	8
6.	Price	10 (10)	17 (9)	29 (8)	24 (7)	12 (6)	2 (5)	4 (4)	11 (3)	4 (2)	7 (1)	799	9
7.	Display	9 (10)	23 (9)	28 (8)	24 (7)	7 (6)	5 (5)	6 (4)	3 (3)	6 (2)	9 (1)	810	7
8.	Variety	7 (10)	23 (9)	37 (8)	20 (7)	6 (6)	5 (5)	4 (4)	5 (3)	3 (2)	10 (1)	821	3
9.	Brand	11 (10)	22 (9)	30 (8)	20 (7)	15 (6)	2 (5)	2 (4)	4 (3)	6 (2)	8 (1)	828	2
10.	Service	12 (10)	27 (9)	29 (8)	12 (7)	13 (6)	6 (5)	5 (4)	5 (3)	4 (2)	7 (1)	837	1



INTERPRETATION

The above tables shows out of total 120 respondents, Service hasranked 1st, Brand & Access hasranked 2nd,Variaty has ranked 3rd, Style hasranked 4th, Battery hasranked5th, Usage hasranked 6th, Display has ranked 7th, Camera has ranked 8th, Price has ranked 9th.

INFERENCE

When we comparing to all other preference levels, Service has ranked

FINDINGS, SUGGESTIONS AND CONCLUSION

FINDINGS

SIMPLE PERCENTAGE ANALYSIS

- Majority (66%) of the respondents were female
- Majority (83%) of the respondents were Below 25 years
- Majority (75%) of the respondents were Unmarried
- Majority (65.8%) of the respondents were UG
- Most (40%) of the respondents are Rs.50001 to 100000
- Most (40.8%) of the respondents are Friends
- Majority (78%) of the respondents are For Business
- Majority (88%) of the respondents are Both
- Majority (65%) of the respondents are Necessity
- Most (49%) of the respondents are 1 year
- Majority (90%) of the respondents are Yes
- Most (33%) of the respondents are Camera
- Most (49%) of the respondents are Yes
- Majority (62%) of the respondents are Good advertisement
- Majority (93%) of the respondents are Yes
- Majority (61%) of the respondents are I don't know
- Most (41.7%) of the respondents are Price offer

SIMPLE RANKING METHOD

- When we comparing to all other preference level, Service has ranked 1st

SUGGESTIONS

This study suggested that the marketing techniques and strategies can be improved for Red-mi mobile phones. Most of the respondents came to know about the Red-mi mobile phone only through the family members and friends. The study suggested that the design of the mobile phone can be further improved. To price offers / discount offers to attract more member of customers. The heat reduction also included in the features of redmi mobile phones. It provides 3/4 GB RAM for multitasking.

CONCLUSION

This study concluded that in this modern business economy it is very important to analyses the marketing strategy used in the Red - mi mobile phones. The study result shows the majority of the consumers are satisfied with the Red - mi mobile phones but also there is a drawback such as hike in price and such other factor like design of the product. If necessary steps to re-solve problems of retaining customers of Red - mi mobile phone will be high. It will develop the strategy of marketing, if the company can understand the preference and overall perception of the consumer. Hence, it will develop the marketing strategy and market share of Red - mi mobile phone Company.

REFERENCE

1. N.Senthilkumar & K.Sabari ram & K.Kumaravel(2019), "A Study on consumer satisfaction towards Oppo mobile in erode district", *Intercontinental Journal of Marketing Research Review*, Vol.7, Issue 3, pp.no:1 – 4.
2. Dr.R.Eswaran & M.Senthil (2016), "A Study on customer satisfaction towards Nokia mobile phones in Salem city", *International journal of applied research*, Vol.2, issue 9, pp.No:100-102.
3. Nushrat Nahida Afroz (2017), "Students' brand preference towards smart phone", *IOSR journal of business and management*, Vol.19, issue.2, pp.No:37-44.
4. R.Venkatesh kumer & K.Tamil selvi (2017), "A Survey on consumer behavior towards Samsung mobile", *Intercontinental journal of marketing research review*, Vol.5, issue.3, pp.No:9-14.
5. J.Sathya & K.Varunapriya (2015), "A Study on customers' preference and satisfaction towards android mobiles with reference to Coimbatore city of India", *International journal of Interdisciplinary and Multidisciplinary studies*, Vol.2, No.5, pp.No:83-85.



DESIGN AND ANALYSIS OF MULTILEGGED ROBOT FOR ENVIRONMENT MONITORING

¹Dr Jose Mathew, ²Lissen Sam, ³Lovin George Mathew, ⁴Merin T Edison, ⁵Pratibha Rachel John

ABSTRACT

A modern technological era marked by the onset of robotics and automation into every industrial field has increased the necessity to develop products for a wide range of applications, taking into consideration the cost, functionality, and authenticity of the product from a consumer's viewpoint. An attempt is made in this design work to design and analyse a hexapod mobile robot for environmental exploration. The mechanical part involves the mechanism that drives the hexapod in a forward, backward motion or to make a turn with the help of a walking-like motion created by the Theo Jansen mechanism. The mechanism involves a single input actuator to rotate the crank that subsequently moves each link with a relative motion to perform the walking. The basic linkage is modified in the dimensions by analysing for a path to get the appropriate step height. Sensors for measuring the particulate matter and to monitor the temperature with humidity of the atmosphere is incorporated in the product. The user gets the interface through an application where directional control and sensor system values are received through the Wi-Fi system.

1. INTRODUCTION

The need for large-scale persistent environmental monitoring has become particularly relevant in recent times after a set of serious natural disasters and environmentally harmful accidents. In India, development is having a growing impact on the environment. The environmental issues are increasing on the agenda of different organisations. These objectives are only achieved by proper technologies and it should provide measurable indications, based on existing data, observable, collected over a regular interval, widely accepted, easy to understand, comparable, and balanced between positive and negative impacts (UNDP 2020).

The application of hexapods in monitoring is getting more significant because of the need for accessing emissions remotely (Mouillot et al. 2014). It is important to monitor data which considers air pollution levels and obtain patterns. According to the recent global burden of disease (GBD) estimates, in

2016, estimated premature deaths are 1,030,000 due to outdoor and 780,000 due to household PM2.5 pollution (Bowe et al. 2019). The pollutant level assessments can be used for creating management plans for controlling emissions. A WHO global comparative analysis of air pollution concluded that ambient air pollution increased by 8% between 2008 and 2013 (WHO 2016). It also showed stringent policies or disruptive technological changes, increasing economic activity, and energy demand will lead to a significant increase in global emissions of air pollutants in the future. Thus, air pollution can indicate the underlying baseline assumptions of economic growth but at a slower pace (Rumpf 1990).

The OL-Sensor -MQ135 is used for gas concentrations and it responds from the change in resistance. When target pollution gas exists, sensitive material (SnO₂) of the MQ135 gas sensor's conductivity increases with gas concentration (Husain et al. 2016). Another sensor is Electrobot DHT11



Digital Temperature & Humidity Sensor Module which is highly reliable and excellent long-term stable digital temperature and humidity sensor (Srivastava, Kesarwani and Dubey 2018). NodeMCU V2 Esp8266 used for simple & smart, interactive, programmable & Wi-Fi enabled control (Saputra and Lukito 2017). NodeMCU has inbuilt Wi-Fi which is cheap compared to other devices and it helps in remote access (Patel and Devaki 2019). The system is accessible from any remote location around the globe provided an internet connection (Shelke et al. 2018). It can serve as an Access Point AP, Wi-Fi station or both station and AP together (Aziz 2018). Nova PM SDS011 is used for Particulate Matters and it can get the particle concentration between 0.3 to 10 μ m in the air and it has a digital output and a built-in fan for stability and reliability (Shinde 2020). Tower Pro MG995 Servo Motor is used for actuation. Since the application is based on mobile emission detection, these products can be efficiently used for measuring such trends (S. Fajardo et al. 2016).

The Theo Jansen mechanism is made up of seven to eight linkages with one crank, two oscillating rockers and two couplers all connected through pivot joints (Mohsenizadeh and Zhou 2015). The aim of a walking gait is smooth transitions with desired displacements. Some studies show trajectory techniques can be developed using polynomial functions (Ya-xin and Bo 2014). The driving forces are peculiar in legged motion and it also affects the body acceleration (Winkler 2018).

A hexapod that can traverse through varied terrain for air quality monitoring is the main functionality involved in this design. Electronic systems are integrated into a compact body with different sensors and power sources. The motion mechanism uses servo actuators and Theo Jansen motion mechanism, for the motion of leg with a single crank actuation. The application extends widely from local area monitoring to networked systems that lie under the future scope. Cost-effective and purpose-

oriented product development are the important pillars of this design.

2. METHODOLOGY

The basic idea of the product to be developed is made from the initial concept of a robot for environmental exploration purposes. The reviews from people at different domains mainly focused on tackling the pollution problems with an advanced technological approach. The motion mechanism adopted for the hexapod is "Theo Jansen Mechanism" which with its single crank motion to produce leg motion, can be facilitated for the product motion. The crank can be actuated by a servo motor and a controller for its defined timely rotation as per the need. The mechanism is analysed through a path analysing software and is optimized. The final structure is produced as a CAD model in Solid works software with the obtained link dimensions. The walking gait is developed by studying the required angular and directional motion of the leg with particular timing to obtain a controlled walking motion of the 6 legs for the movement of hexapods. The control codes to the servo motor are altered according to the specific needs of motion.

A humidity and temperature sensor, PM sensor, the gas sensor is included with the gas sensing system to check the presence of unwanted gas and particulate matter. A basic body structure is made in SolidWorks and the leg is assembled to it with the predefined dimensional criteria and clearances. It is optimized after analysing the structural functionality and degree of freedom and is tested for any misalignments. After continuous iterations, the assembly is finalized with legs, servo motors, electronic components and necessary support structures.

3. DESIGN AND ANALYSIS

The primary objective is to develop a design for sensor integrated hexapod in environment monitoring and suggest optimizations on current hexapod robot designs and their applicability in environmental monitoring with development of sophisticated & simpler walking gait with single rotor power for each leg.

3.1 Graphs & Results (SAM Analysis)

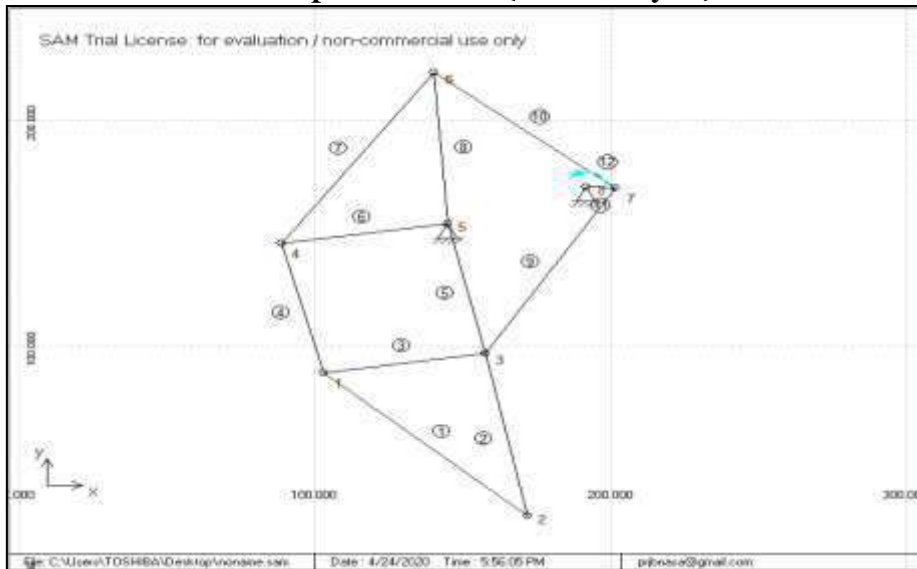

Figure 3.1 Theo Jansen linkage on SAM Interface

Figure 3.1 is the linkage produced on the SAM (Simulation and Analysis of Mechanisms) software interface with the help of hinges and link tools available in the software. A scaled model (1:1.5) is created for the Theo Jansen proportion to start with

initially. The circled numbers represent the links while the plain numbers represent the nodes in the linkage. The rigid triangular portion of the linkage (h, g, i) and (d, e, b) are (1,2,3) and (6,7,8) respectively. The rocker linkages (f) and (c) are (4) and (5) respectively. (k) and (j) are (9) and (10). The crank (m) is (11). The rotation produced by the motor is depicted as (12).

Table 3.1 Link dimensions

	h	i	g	f	c	d	e	b	k	j	M
1	91.79	73.66	49.73	64.04	58.65	57.46	88.60	67.16	90.01	83.06	14.3
2	100.1	68.50	55.11	56.82	60.67	55.47	68.75	55.68	84.15	86.96	12.9
3	83.63	67.49	58.76	50.82	53.33	62.30	81.04	52.38	83.78	71.24	13.1
4	86.64	58.45	49.92	54.59	58.18	53.16	65.66	47.36	82.21	71.28	14.0
5	95.06	62.43	53.10	48.88	53.69	56.25	69.57	49.06	74.64	77.34	12.5
6	80.76	67.78	55.4	49.35	48.99	57	70.4	53.69	71.00	72.37	10.3
7	87.82	62.77	49.75	51.79	45.14	49.57	68.12	48.31	63.91	63.01	12.2
8	92.51	59.55	52.30	52.41	48.36	49.23	74.71	52.49	65.22	64.45	15.3

Table 3.1 shown above is the different dimensions of the linkages when simulated for different paths with varied link dimensions and crank angles with it. Changing each link dimension changes the overall path trajectory, the step height and the ground contact patch during the motion. All the values are in “mm” and the unit provides precision than simulating in “cm”. The rise height is shown in table

4.2 and can be compared to choose the suitable one. The values are in “mm” and can be seen that the step height can be varied from approx. 7 cm to less than 1 cm. The selection will depend on the path width, link interference during motion and other manufacturability factors. Figure 3.2 shows the different paths traced by each linkage from 1 to 8 in the table represented above. The instantaneous points are plotted together in the



software at each node to visually represent the path traced by the linkage at each node. The path trajectory and the step height can be seen in the figures below. The graphs are also available for each linkage set but it

is not included in this report as the main focus is on the linkage that is chosen for the motion purpose, which is described in detail below

Table 3.2 Step /rise Height

	1	2	3	4	5	6	7	8
Step height	69.08	40.537	24.37	46.463	47.693	8.207	50.92	47.80

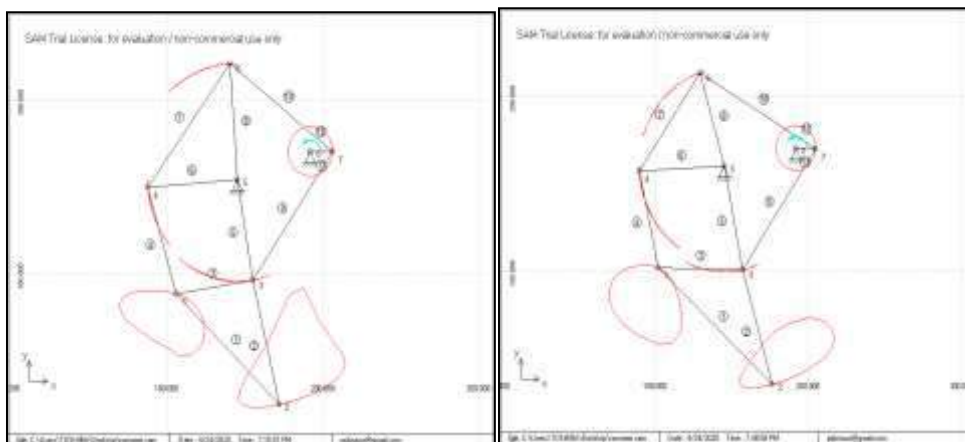

1

2

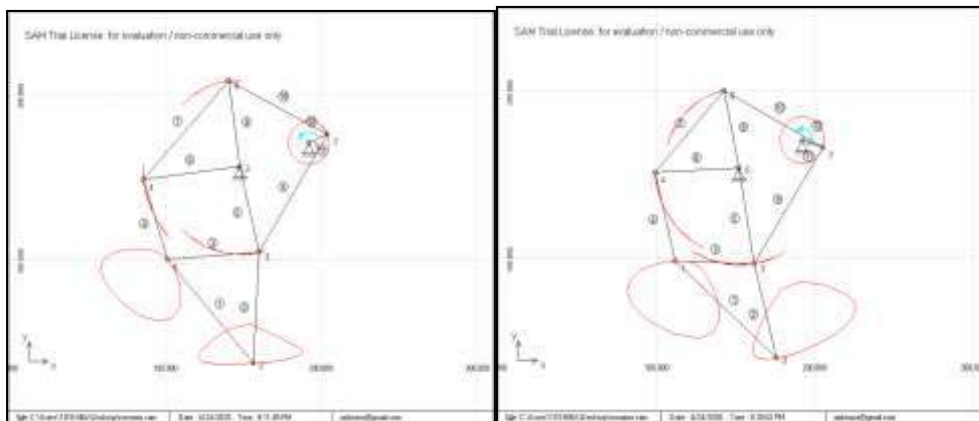

3

4

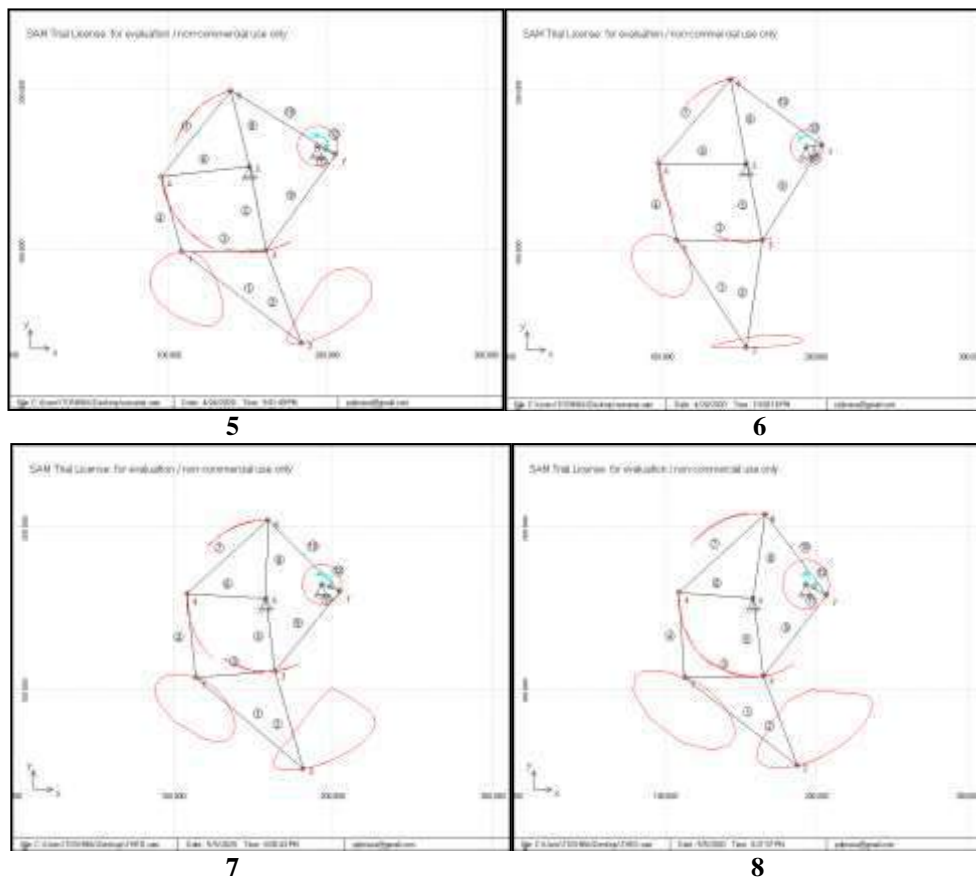

Figure 4.2 Trajectories of the motion path with different link dimension

The selected trajectory and link dimensions are (8) with crank angle 154.103° . The width of the path and the height of the step seems to be suitable compared to the other trajectories while taking into consideration the minimum length needed for the crank for ease of manufacturing (1.5 cm) and keeping the overall size of the linkage small. Figure 3.3 shows the instantaneous position when the leg touches the ground

and hence at its lowest height possible in its trajectory based on the vertical axis. The graph is Position vs. Time graph which traces the position of the leg at each second in a 60-step process. The lowest point is at 51.734 mm according to the x-y graph Figure 3.4 shows the path trajectory when the leg points to its peak. According to the x-y graph, the height is marked at 99.535 mm.

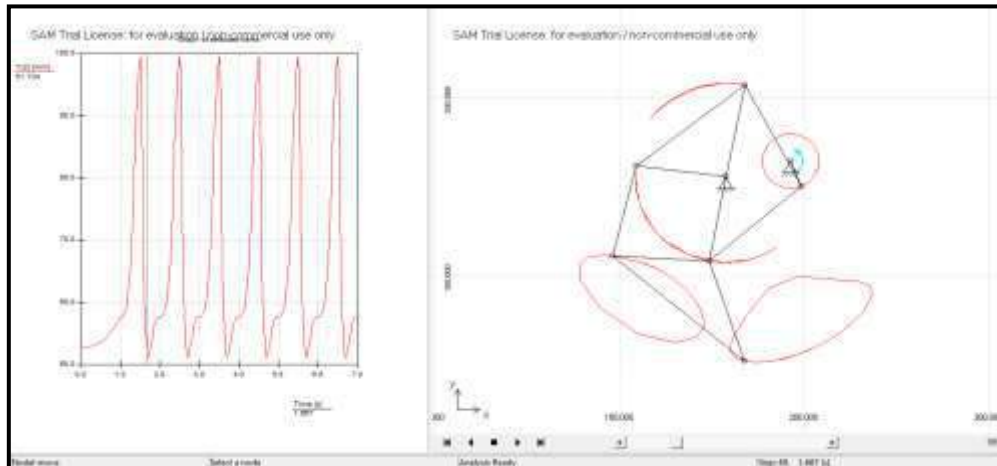

Figure 3.3 Leg at its lowest point on the path

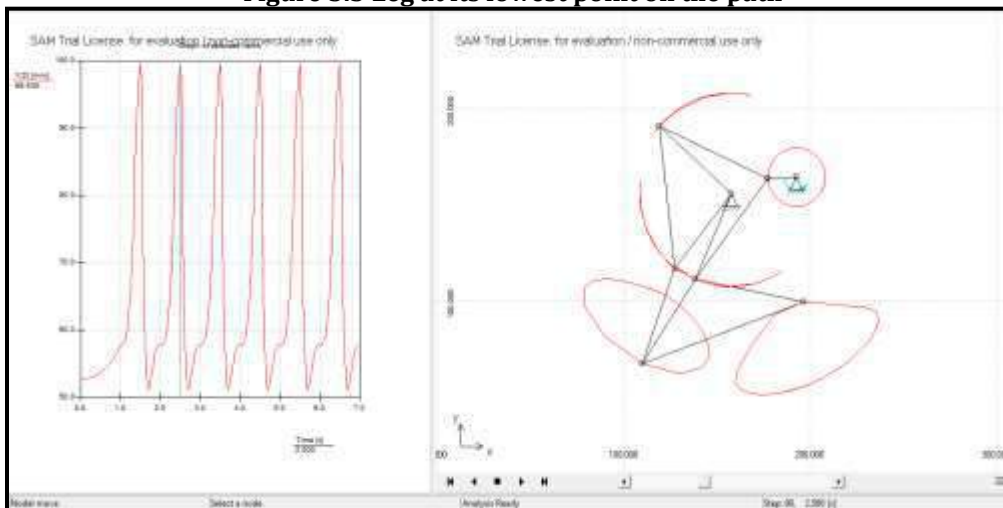

Figure 3.4 Leg at its highest point on the path

Taking the difference between the highest and lowest point with the reference coordinate will give the step height or rise height of the trajectory.

Step height= {Highest Point height - Lowest point height}

$$= \{99.535 - 51.734\}$$

$$= 47.801 \text{ mm} = 4.7 \text{ cm}$$

3.2 CAD Model - Theo Jansen Linkage

The CAD model of the linkage with the dimensions selected from the analysis is made with the help of SOLIDWORKS software. In addition to the basic linkage system, a grip structure for the leg is implemented for the ease of motion with an aided

support of the leg. The model is shown in Figure 3.5 with its dimensions of each link represented. The hole inserted for the hinge is 0.5 mm. This is the basic model of the leg used for the hexapod in this project. Further simulations of the leg for strength are possible in other advanced software like ADAMS or ANSYS but the scope of this project doesn't allow for deep simulations as the force distribution is approximately even for the hexapod and the actuators (servo motors) doesn't impose a heavy load on the crank. The individual parts in the linkage can be seen in figure 3.6 displayed below. The triangular sets, rocker links and other links with the crank can be seen from the figure.

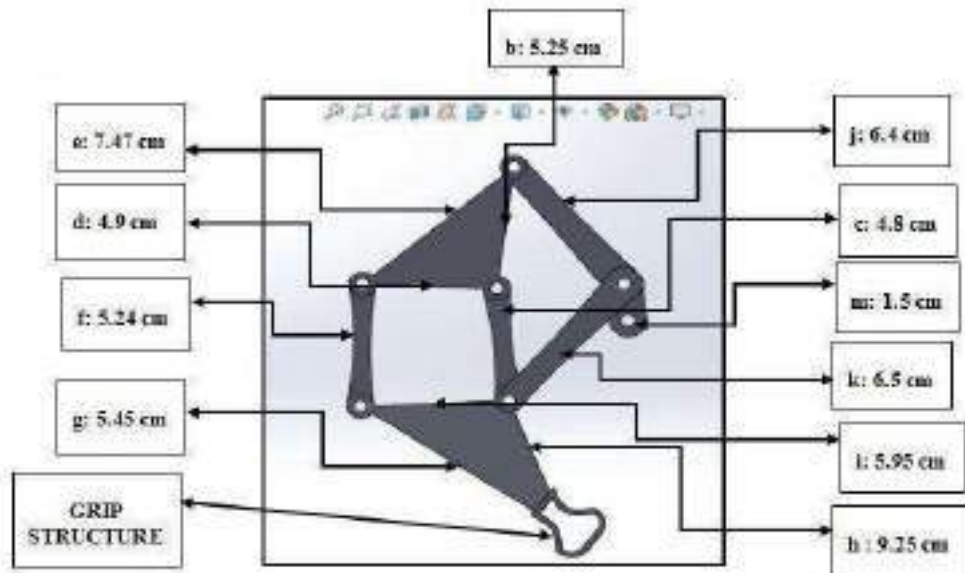

Figure 3.5 CAD model with link dimensions

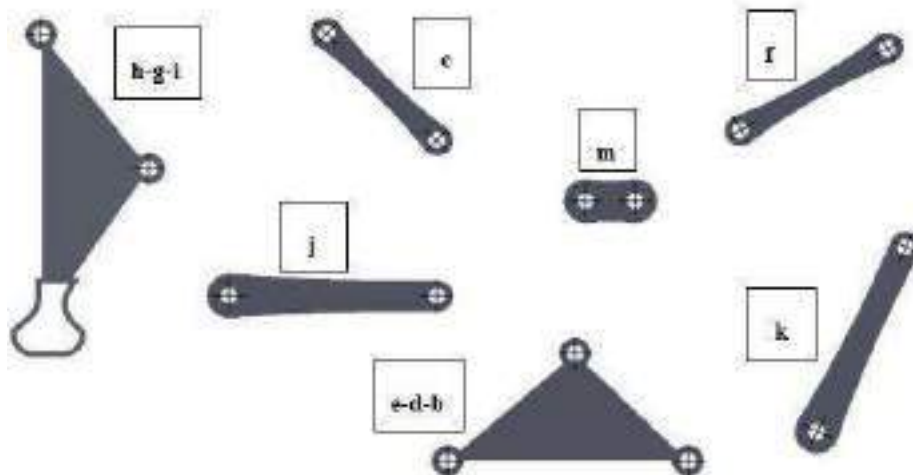

Figure 3.6 Parts of the linkage

3.3 ELECTRONIC CIRCUIT AND CONTROL SYSTEM

The primary objective of the circuit design was to integrate the sensor system and control to the user. The electronics circuit consists of NODEMCU, gas sensor, temperature and humidity sensor, PM sensors and motors. A voltage regulator circuit is given to regulate the power distribution. The voltage and current

consumptions are given in Table 3.3. Figure 3.7 shows the designations for the motors and the legs. L represents the left leg and R represents the right leg. M represents motors and they are numbered from one to six. The motion primarily depends on the directions of rotation of motors. These are given in Table 3.4. The motors are actuated according to the direction of motion.

**Table 3.3 Electronic components**

COMPONENTS	VOLTAGE	CURRENT
NODEMCU ESP8266	3V-5V	10uA~170mA.
MQ135	5V	150mA
DHT-11	5V	0.5mA
PM SENSOR	5V	70mA±10mA
SERVO MOTOR	4.5V	Stall current:1200mA

Table 3.4 Commands and motor actuation

	M1	M2	M3	M4	M5	M6
Left	no motion	c.c.w.	no motion	c.w.	no motion	c.w.
Backward	c.w.	c.w.	c.w.	c.c.w.	c.c.w.	c.c.w.
Forward	c.c.w.	c.c.w.	c.c.w.	c.w.	c.w.	c.w.
Right	c.c.w.	no motion	c.c.w.	no motion	c.w.	no motion
Stop	no motion	no motion	no motion	no motion	no motion	no motion

**Figure 3.7 Motors and Leg designations**

3.5 CAD ASSEMBLY

An assembly model of the hexapod is made in SolidWorks 2018 with the components integrated, i.e. Gas sensor (MQ135), Temperature and Humidity sensor(DHT-11), PM sensor(at an elevated surface in the assembly to facilitate efficient functionality by detection of airflow), Battery pack(at the rear end), the Circuit board(situated within the platform provided on the structural body) and the Servo motors attached to the six legs which are secured by a bracket for the front & rear motors and a seat like structure for middle motors, built within the structural base body to mount the servo securely. An elevated pavement is designed to mount the PM sensor. The battery pack is securely placed and fixed on to a structure designed behind the elevated platform in a slanting position to facilitate easy removal and also to incorporate within the structure with balanced weight distribution. On to the

base structure, all the components are placed in such a way that the components don't hinder the functionality of each other and there is enough room for the electronic component to give up the heat produced during the working. The servo motors are kept following the clearance required for the smooth operation of the Theo Jansen leg motion. Figure 3.8 below shows the different views of the assembly model of the product.

The structural member that acts as the base and support to accommodate all the components of the hexapod is shown in Figure 3.9. It is designed to accommodate the circuit board and other components. The size of the leg was another consideration taken to design the appropriate size of the body member. The clearances were measured by virtual means in the software to ensure the proper motion of all the legs

without interfering with the body structure. The incorporation of the servo motor and its attachment members were also checked for dimension and measured before designing the supportive members and mounting brackets. An elevated pavement can be seen on the structure which is meant for mounting the PM sensor to facilitate its proper functioning. The battery is

mounted to the rear of the hexapod due to design constraints within the available dimensional space and to distribute the weight of the total components equally within the body. The dynamic weight distribution during motion is not taken into consideration as it is out of the project scope.

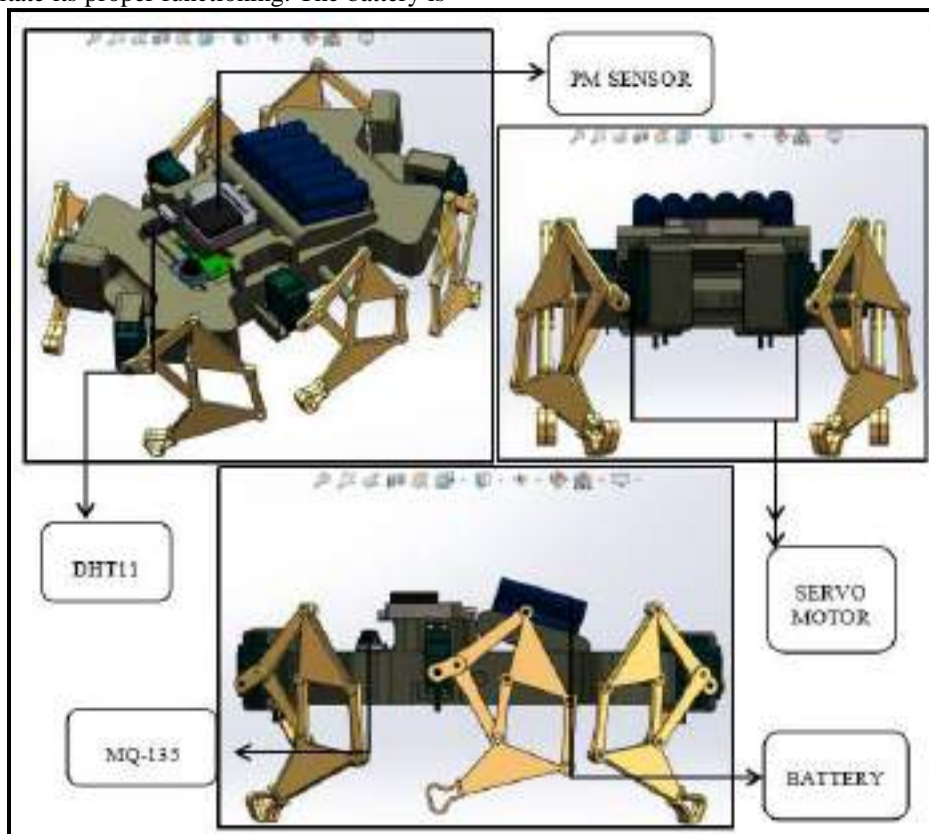

Figure 3.8 Assembly model with components

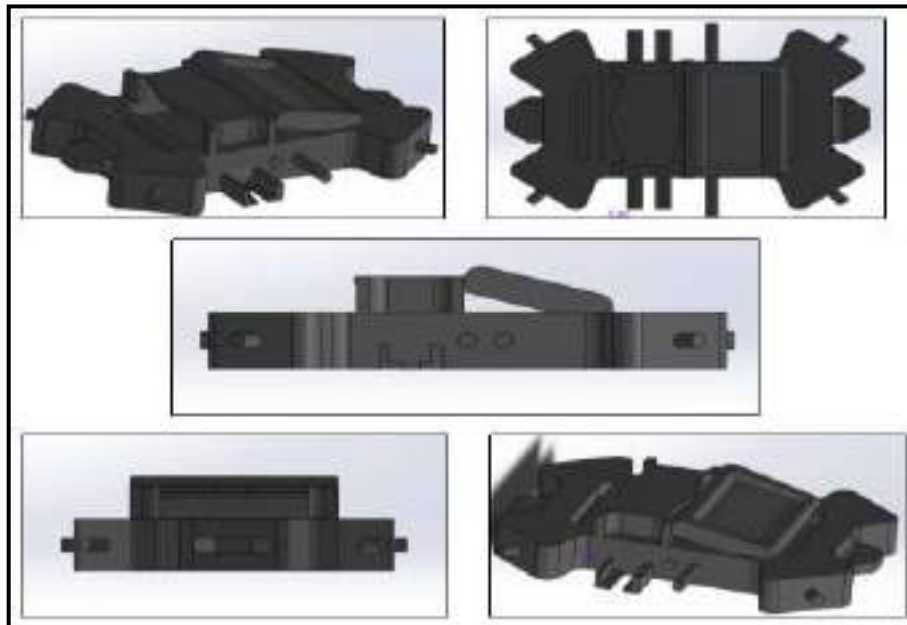

Figure 3.9 Base structure with mounting platform

3.6 WORKING

The timely control of the motor is obtained through a microprocessor “NodeMCU”, that can be incorporated with specific computer application to provide the desired motion which is explained in detail in the further chapters. The walking gait is developed by studying the required angular and directional motion of the leg with particular timing to obtain a controlled walking motion of the 6 legs for the movement of hexapods. The control codes to the servo motor are altered according to the specific needs of motion.

The user has a control interface in the Blynk app. For this user connects the mobile with the product. When the product is turned on, the reading from sensors is shown on mobile. The user interface is provided with control. When control is used the motors move as per the instructions given in mobile. This gives an indication of air quality over an area. The working is shown in figure 3.10.

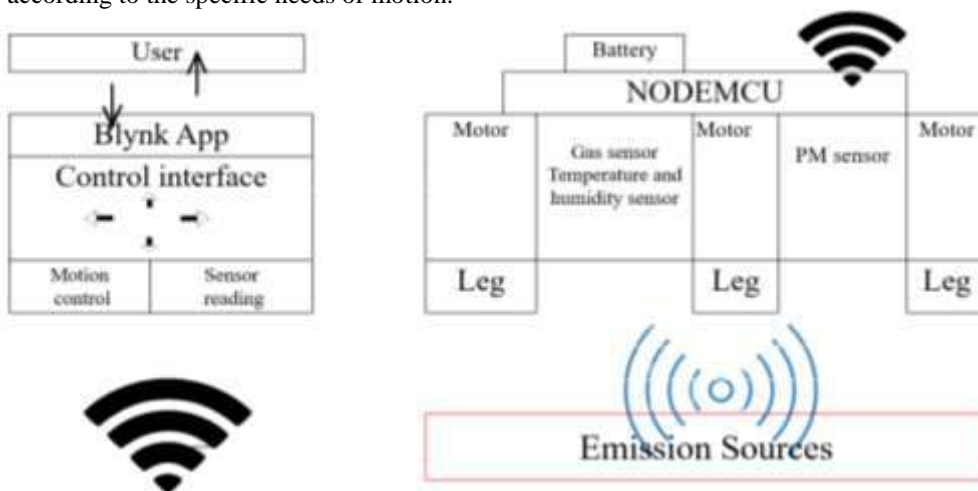

Figure 3.10 Working of hexapod



4. CONCLUSIONS

The application of an efficient yet simple multi-legged robot for environment exploration mainly for the quantification and subsequent analysis of air quality across a region, summed up, forms the work done in this project. Starting with the need for such a technological concept for society, the deteriorating level of air quality and its effect on the human population is briefly studied from authenticated sources. The appropriate mechanism to drive the robot and its efficiency in a less complicated manner were incorporated using the Theo Jansen mechanism which perfectly did the role of legs of the product. The selection of six legs and hence a hexapod was deliberately chosen because of its added advantage of stability and degree of motion compared to four-legged robots or wheeled robots. The basic CAD design of the leg is done in Solid works after analysing the link dimensions in SAM software where the required path is analysed and step height is chosen. The selection of gas sensors, particulate matter sensor, and temperature-humidity sensor is done based on the market availability, cost and sufficient functionality as per the scope of this project and hence MQ135, NovaPM-SDS011 and DHT11 are chosen. The control system to integrate the electronic circuit is done with NodeMCU which also has Wi-Fi connectivity. The user interface is developed using BLYNK application through which directional control of the hexapod and real-time sensor values can be availed through the Wi-Fi system. The circuit system is designed in Proteus software to a compact PCB. The role of the actuation system is done by six servo motors, one for each leg. The entire

REFERENCE

1. *Undp.org*. 2020. [online] Available at: <https://www.undp.org/content/dam/india/docs/analysis_of_existing_environmental_instruments_in_india.pdf> [Accessed 1 April 2020].
2. Mouillot, F., Schultz, M.G., Yue, C., Cadule, P., Tansey, K., Ciais, P. and Chuvieco, E., 2014. Ten years of global burned area products from spaceborne remote sensing—A review: Analysis of user needs and recommendations for future developments. *International Journal of Applied Earth Observation and Geoinformation*, 26, pp.64-79.
3. Bowe, B., Xie, Y., Yan, Y. and Al-Aly, Z., 2019. Burden of cause-specific mortality associated with PM_{2.5} air pollution in the United States. *JAMA network open*, 2(11), pp.e1915834-e1915834.
4. WHO 2016 Ambient air pollution: A global assessment of exposure and burden of disease [online] Available at: <<https://apps.who.int/iris/bitstream/handle/10665/250141/9789241511353-eng.pdf>> [Accessed 5 March 2020].
5. Rumpf, H., 1990. The characteristics of systems and their changes of state disperse. In Part. Technol., Chapman and Hall (pp. 8-54).
6. Husain, A.M., Rini, T.H., Haque, M.I. and Alam, M.R., 2016. Air quality monitoring: The use of arduino and android. *Journal of Modern Science and Technology*, 4(1), pp.86-96.
7. Srivastava, D., Kesarwani, A. and Dubey, S., 2018. Measurement of Temperature and Humidity by using Arduino Tool and DHT11. *International Research Journal of Engineering and Technology (IRJET)*, 5(12), pp.876-878.
8. Saputra, L.K.P. and Lukito, Y., 2017, November. Implementation of air conditioning control system using REST protocol based on NodeMCU ESP8266. In 2017 International Conference on Smart Cities,

mechanical structure with the electronic system is assembled in Solid works to form the virtual model of the final product. The walking gait chosen is a tripod gait that ensures at least three legs at the ground every time during the motion. The controlled motion is analysed by depicting the gait with timely inputs of motor actuation and checking the contact, the non-contact sequence of the legs in a graphical form.

FUTURE SCOPE

The product is explained in this project can be taken to another advanced level with the integration of more sophisticated electronic components for different purposes, improve the design and aesthetics of the product, manufacturing with the help of 3D printing and laying down alliances with different organizations to expand the scope of the product with collaborations from different like-minded companies. The electronic system can improvise in sensors to measure a wide range of harmful gases specifically showing its respective amount in the atmosphere, cameras to aid the manoeuvrability, a signal system to receive and send pieces of information to a distant point and a fleet system where multiple robots can be deployed to different areas around a locality to monitor the air quality of a larger part. The design could be modified into a covered system with proper heat dissipation vents, improve dynamic stability by controlled damping techniques and could be altered in such a way to incorporate rotational features.



- Automation & Intelligent Computing Systems (ICON-SONICS)* (pp. 126-130). IEEE.
9. Patel, A. and Devaki, P., 2019. Survey on NodeMCU and Raspberry pi: IoT
 10. P. Shelke, S. Kulkarni, S. Yelpale, O. Pawar, and R. Singh, (2018) "A NodeMCU Based Home Automation System International. Research. Journal of Engineering and Technology. 8(4) pp. 127–129, 2018.
 11. Aziz, D.A., 2018. Webserver based smart monitoring system using ESP8266 node MCU module. *International Journal of Scientific & Engineering Research*, 9(6), pp.801-808.
 12. S. Shinde The SDS011 Air Quality Sensor experiment [online] Available at: <<https://aqicn.org/sensor/sds011/>. May 29 2020]
 13. S. Fajardo, García-Galvan, F. R., V. Barranco, J. C. Galvan, and S. F. Batlle. *Methods for online monitoring of air pollution concentration Intech*(2016).
 14. Ya-xin, Y. and Bo, J., 2014. Gait generation and control of a hexapod walking robot. *The Open Electrical & Electronic Engineering Journal*, 8(1).
 15. Winkler, A.W., 2018. Optimization-based motion planning for legged robots (Doctoral dissertation, ETH Zurich)
 16. Mohsenizadeh, M. and Zhou, J., 2015. Kinematic analysis and simulation of Theo Jansen mechanism (Doctoral dissertation, Lamar University).



A STUDY ON CUSTOMER PREFERENCE TO ROYAL ENFIELD WITH SPECIAL REFERENCE TO COIMBATORE CITY

Prasath.M

*Student of III B.Com.(PA), Department of Commerce with Professional Accounting,
Dr. N. G. P Arts and Science College, Coimbatore*

P.Dhanya

*Assistant Professor, Department of Commerce with Professional Accounting,
Dr. N. G. P Arts and Science College, Coimbatore*

ABSTRACT

This study is to analyze the customer satisfaction, towards Royal Enfield bikes in Coimbatore city. The objective of the study helps to know demographic factors, buying behavior, of the customers. This study is about the preference for the Royal Enfield and it is done through questionnaires from the customers. The tools and techniques used were simple percentage, chi-square. The achieved result of the study reveals that ultimate users are the students who uses Royal Enfield Bike and most of the respondents prefer Royal Enfield due to company image and comfortable. The company must improve their mileage, model and colour in their Royal Enfield Bike.

KEYWORDS : *Royal Enfield, Customer Preference, Bullet, Automobiles*

INTRODUCTION

Motor cycles in India date back to the year 1955, when the Government of India required strong, rough and tough motorcycles for Indian army and the police force in the western part of the country which had a rough and craggy terrain. The 350cc "Bullet" manufactured by the Royal Enfield company of United Kingdom was the first motorcycle in India. These motorcycles were put together in Chennai. This was the beginning for the Indian two wheeler industry. The motorcycles in India cater a variety of needs of consumers. It has become one most popular models of transportation, and its preferred by the daily commuters. The segment of motorcycles went through a tremendous change in the 90s and the two wheeler market, especially the motorcycle market was filled with options.

STATEMENT OF THE PROBLEM

Customer satisfaction plays a crucial role in enabling an organization to change and develop with customers. Keeping the existing customer contented is generally much easier, takes less time and involves less expense. The reason for this is that it takes more time to find new prospective customer. In this context study is conducted with special reference to customer preference. A company can earn more profits only when it has strong customer care towards product and services offered by the company. So to have stronger customer care it has to provide a competitive price further advertising to increase.

SCOPE OF THE STUDY

- The research was carried out to find out the factors which influence the customer perception to Royal Enfield.



- The study is mainly on Royal Enfield bikes with the comparison brought out which shows the name of Royal Enfield.
- The study underwent is related to urban areas and semi-urban areas at Coimbatore city.
- The main reason for selecting the location for study is that this place is one of the booming markets for two-wheelers in Tamil Nadu.
- To suggest various factors to improve sales.

OBJECTIVES OF THE STUDY

- To study about the Royal Enfield company.
- To study about customer preference to Royal Enfield.
- To analyze factors influencing in selection of Royal Enfield.
- To know about the performance of Royal Enfield.

TOOLS FOR ANALYSIS

The primary data were coded, classified, tabulated and analysed. The statistical tools used for analysis of the study are:

- Simple percentage Analysis
- Ranking Correlation

LIMITATION OF THE STUDY

- The study is conducted to Royal Enfield customers.
- The study is conducted with special reference to Coimbatore city.
- The view & opinions of the customers are subject to change with changing time.

REVIEW OF LITERATURE

K. Reenareichal (2019) in her study “A study on customer satisfaction towards Royal Enfield bike in Tiruppur city” states that, Royal Enfield dealers that the customers are satisfied or not. Royal Enfield bikes is very economical and most of them prefer to buy the bike brand new from showroom. Royal Enfield has an

excellent satisfaction within the customer for its power, pick up, comfort and safety.

G.Gopalakrishnan & R. Rengarajan (2018) “ A study on service quality in Royal Enfield showroom in Chennai” stated that, Royal Enfield has to close the gap between customer’s expectation and perception of services. In order to enhance service quality, customer attraction should be retained, and competitive advantages should be gained, people based on companies should increase employees attitude, training and improve their knowledge of services.

Mrs.G.Murali Manokari (2013) in her study “ A study on customers preference towards Royal Enfield motorbikes in Coimbatore city TamilNadu” stated that, Royal enfield customers preferences and their satisfaction level towards various aspects. The manufacturers should provide best combination of looks, Quality, Cost efficiency, Good features, Safety, Luxury and Performance.

DATA ANALYSIS AND INTERPRETATION

In this chapter the analysis and interpretation of “A study on customer preference to royal enfield with special reference to coimbatore city”is presented based on the opinion of samples of 120 respondents selected from Coimbatore city through a questionnaire containing 20 questions. These were analysed through three different tools and they are as follows,

- Simple Percentage analysis
- Rank Correlation

SIMPLE PERCENTAGE ANALYSIS:

Simple percentage analysis is the method to represent raw streams of data as a percentage for better understanding of collected data. Percentage analysis is applied to create a contingency table from the frequency distribution and represent the collected data for better understanding.

**FORMULA:**

$$\text{Percentage} = \frac{\text{Number of respondents}}{\text{Total no. of respondents}} \times 100$$

TABLE 1
TABLE SHOWING THE GENDER OF THE RESPONDENTS

SNO	PARTICULARS	NO. OF RESPONDENTS	PERCENTAGE
1	MALE	80	100
2	FEMALE	0	0
	TOTAL	80	100

*(source: Primary Data)***INTERPRETATION**

From the above table, it is revealed that the 100% of the respondents are male.

Majority (100%) of the respondents are Male.

TABLE 2
TABLE SHOWING THE EDUCATIONAL QUALIFICATION OF THE RESPONDENTS

SNO	PARTICULARS	NO. OF RESPONDENTS	PERCENTAGE
1	UPTO SCHOOL LEVEL	22	27.5
2	GRADUATE	23	40
3	POST GRADUATE	26	32.5
4	PROFESSIONAL	0	0
	TOTAL	80	100

*(source: Primary Data)***INTERPRETATION**

From the above table, it is revealed that the 27.5% of the respondents are qualified upto school level, 40% of the respondents are qualified

graduation, 32.5% of the respondents are qualified till post graduate and 0% of the respondents are professional.

Majority (40%) of the respondents are Graduate.

TABLE 3
TABLE SHOWING THE OCCUPATIONAL STATUS OF THE RESPONDENTS

SNO	PARTICULARS	NO. OF RESPONDENTS	PERCENTAGE
1	STUDENT	0	0
2	EMPLOYER	39	48.75
3	EMPLOYEE	41	51.25
4	PROFESSIONALS	0	0
	TOTAL	80	100

*(source: Primary Data)***INTERPRETATION**

From the above table, it is revealed that the 48.75% of the respondents are employers, 51.25% of the respondents are employees.

Majority (51.25%) of the respondents are employees.



TABLE 4
TABLE SHOWING THE SATISFACTION LEVEL OF PERFORMANCE OF THE BIKE

SNO	PARTICULARS	NO. OF RESPONDENTS	PERCENTAGE
1	0-20%	0	0
2	21-40%	0	0
3	41-60%	0	0
4	61-80%	0	0
5	81-100%	80	100
6	ANSWERED NO	0	0
	TOTAL	80	100

(source: Primary Data)

INTERPRETATION

From the above table, it is revealed that the 100% of the customers are satisfied with the bikes performance level of 81-100%.

Majority (100%) of the respondents are satisfied with the bikes performance level of 81-100%.

TABLE 5
TABLE SHOWING THE RESPONDENTS FINANCE PLAN TO PURCHASE THE BIKE

SNO	PARTICULARS	NO. OF RESPONDENTS	PERCENTAGE
1	FROM SAVINGS	48	60
2	FROM LOCAL FINANCE	0	0
3	LOAN FROM BANK	32	40
	TOTAL	80	100

(source: Primary Data)

INTERPRETATION

From the above table, it is revealed that the 60% of the respondents prefer to buy using savings, 40% of the respondents prefer to buy using loan from bank and 0% of the respondents prefer to buy using local finance.

Majority (60%) of the respondents prefer to buy using savings.

different ranking of the same variables, where a “ranking” is the assignment of the labels “first”, “second”, “third”, etc., To different observation of a particular variable. A rank analysis measures of similarity between two rankings, and can be used to assess the significance of the relation between them. It is not necessarily a total order of object because two different objects can have the same ranking. The ranking themselves are totally ordered.

RANK CORRELATION

A rank analysis is any of several statistics that measure an ordinal association, the relationship between ranking of different ordinal variables or

TABLE 6
TABLE SHOWING THE RESPONDENTS REASON FOR PREFERING ROYAL ENFIELD

SNO	PARTICULARS	1	2	3	4	5	TOTAL	RANK
1	DESIGN	10(5)	12(4)	18(3)	4(2)	20(1)	225	2
2	BRAND NAME	35(5)	18(4)	13(3)	7(2)	7(1)	307	1
3	SOUND	12(5)	4(4)	21(3)	34(2)	9(1)	216	3
4	DURABILITY	7(5)	20(4)	17(3)	11(2)	25(1)	213	5
5	PERFORMANCE	7(5)	26(4)	13(3)	16(2)	18(1)	228	4

(source: Primary Data)



INTERPRETATION

From the above table, it is revealed that the Brand Name was ranked 1st, Design was ranked 2nd, Sound was ranked 3rd, Performance was ranked 4th and Durability was ranked 5th.

FINDINGS, SUGGESTIONS AND CONCLUSION

FINDINGS

SIMPLE PERCENTAGE

- Majority (65%) of the respondent under the age – group of 19-24 years.
- Majority (100%) of the respondent are Male.
- Majority (70%) of the respondents are unmarried.
- Majority (50%) of the respondents income are Rs.2,00,001 – Rs.3,50,000.
- Majority (40%) of the respondents are graduate.
- Majority (51.25%) of the respondents are employees.
- Majority (57.5%) of the respondents didn't consider any bike before buying Royal Enfield.
- Majority (100%) of the respondents own 4stroke vehicle previously.
- Majority (100%) of the respondents are awarenced by friends.
- Majority (37.5%) of the respondents purchase decision are made by family members.
- Majority (80%) of the respondents plays role as user.
- Majority (72.5%) of the respondents are not using vintage Royal Enfield.
- Majority (61.25%) of the respondents has said their opinion is excellent on the appearance of the bike.
- Majority (45%) of the respondents like to buy classic 350/350.
- Majority (75%) of the respondents liked the ABS facility.
- Majority (100%) of the customers are satisfied with the bikes performance level of 81100%.
- Majority (100%) of the respondents prefer to buy the Royal Enfield in showroom.
- Majority (60%) of the respondents says price of Royal Enfield as expensive.
- Majority (60%) of the respondents prefer to buy using savings.
- Majority (53.75%) of the respondents will surely buy if the price increases.

- Majority (56.25%) of the respondents prefer to participate in Rider mania organized by Royal Enfield.

RANK ANALYSIS

From the above table, it is revealed that respondent's main reason to prefer Royal Enfield is BRAND NAME.

SUGGESTIONS

- This study suggests that the Royal Enfield company should concentrate more at the age group of 25-30 years.
- Most of the respondents are using Royal Enfield for the Brand Name of the company.
- Most of the respondents says price of Royal Enfield as expensive, so slight reduction in price may attract more audience than existing.
- Most of the respondents feel performance of Royal Enfield is not upto the expectation, so increasing the performance would widen the market and increase the customer satisfaction.
- The company should follow an aggressive selling concept. A non-aggressive selling concept which is clearly visible in its sales.

CONCLUSION

The study concludes that why the customers are preferring Royal Enfield. From the survey younger generation and middle age are more interested in Royal Enfield Bullet, the buying behavior is governed predominantly by the need of power and respect for the iconic brand and users are mostly employed males, 19-24 years of age, including some students. Most of the customers are attracted to the new release of classic 350/350, also customers are very loyal towards the brand Royal Enfield Bullet. Most of them prefer to buy their Bike Brand New showroom.

REFERENCE

1. **K. Reenareichal (2019)** in her study "A study on customer satisfaction towards Royal Enfield bike in Tiruppur city" *International Conference on Advancements in computing and Management Volume, pp.no.1-8.*
2. **G.Gopalakrishnan & R. Rengarajan (2018)** "A study on service quality in Royal Enfield showroom in Chennai" *International journal of Management Technology and Engineering, Volume 8 Issue 11.*
3. **Mrs.G.Murali Manokari (2013)** in her study "A study on customers preference towards Royal Enfield motorbikes in Coimbatore city TamilNadu" *Journal of Social and Administrative-Management.*



A STUDY ON CUSTOMER'S SATISFACTION TOWARDS LG PRODUCTS WITH SPECIAL REFERENCE TO COIMBATORE CITY

Dr. R. Mayilsamy

*Assistant Professor, Department of Commerce with Professional Accounting,
Dr. N.G.P. Arts and Science College, Coimbatore*

Harini.D

*Student of III B.Com.(PA), Department of Commerce with Professional Accounting,
Dr.N.G.P Arts and Science College, Coimbatore*

ABSTRACT

LG Corporation established as Lak Hui Chemical Industrial Corp. in 1947. In 1952, Lak Hui (pronounced "Lucky", currently LG Chem) became the first South Korean company to enter the plastics industry. As the company expanded its plastics business, it established GoldStar Co. Ltd. (currently LG Electronics Inc.) in 1958. Both companies Lucky and GoldStar merged and formed Lucky-Goldstar in 1983.

GoldStar produced South Korea's first radio. Many consumer electronics were sold under the brand name GoldStar, while some other household products (not available outside South Korea) were sold under the brand name of Lucky. The Lucky brand was famous for hygiene products such as soaps and HiTi laundry detergents, but the brand was mostly associated with its Lucky and Perioe toothpaste. LG continues to manufacture some of these products for the South Korean market, such as laundry detergent.

Koo Bon-moo renamed the company to LG in 1995. The company also associates the letters LG with the company's tagline "Life's Good". Since 2009, LG has owned the domain name LG.com.

INTRODUCTION

The project is entitled as "a study on the customer satisfaction towards LG PRODUCTS with special reference to Coimbatore city is carried out with the objective to determine the customer satisfaction.

(i) CONSUMER BEHAVIOUR

Consumer behaviour is the study of individuals, group, or an organisation and the process they used to select, secure, use and dispose of products, services, experiences or the ideas to satisfy their needs and wants. Consumer behaviour is the behaviour exhibited by people in planning, purchasing and using the economic goods and services. Consumer

behaviour is the integral part of the human behaviour and cannot be separated from it. In fact the consumer behaviour is a subject of human behaviour. This does not mean that all human behaviour is consumption oriented. Human behaviour refers to the total process by which individuals interact with their environment.

(ii) CUSTOMER SATISFACTION

Customer satisfaction is a term frequently used in marketing. It is a measure of products and services supplied by a company to meet customer expectation.



STATEMENT OF THE PROBLEM

It is a struggle that there is competition to the LG products in the market. There is less quality in its products comparing to others. Now in the present century new technologies introduces new brands of electronic items, every day the new arrival of electronic items has made the companies constantly engaged in gaining attention of the consumer like price, offer etc., so comparing to others LG has not adopted the new technologies. The solution for improving the LG PRODUCTS is to be analysed.

SCOPE OF STUDY

The main aim is to examine the customers level of satisfaction on LG PRODUCTS with special reference to Coimbatore city. This study helps in understanding the needs and changes to be done in LG PRODUCTS. It will also helps in finding out the customers opinion on the technical and services support rendered by the LG COMPANY. The survey focus on the opinion of the respondents regarding the LG PRODUCTS.

OBJECTIVE OF STUDY

- To determine the major factors influencing the buying behaviour of the customer.
- To know the customers opinion towards the LG PRODUCTS.
- To find out the problems faced by the consumer on buying the product.
- To analyse the level of satisfaction towards the LG PRODUCTS.

STATISTICAL TOOL USED

- ✓ Simple percentage analysis
- ✓ Liker scale analysis

REVIEW OF LITERATURE

Janaki and Shanthi, (2013) in their study entitled, "Marketing Stimuli in Purchase of Home Appliances From Customer Perspectives", explains that marketing strategy is the game plan which the firms must adhere to, in order to outdo the competitor or the plans to achieve the desired objective. The people consume things of daily use, and buy these products according to their needs, preferences and buying power. The objectives of the study are to study the purchase decision behaviour relating to home appliances and to analyze customer response to the marketing stimuli of home appliances. The study was carried out with the sample size of 200 respondents selected based on proportionate random sampling with in Coimbatore city. The data were collected with interview schedule and were analyzed using percentage weighted average score analysis of

variances. The findings of the study included that education and income of the respondents are the two socioeconomic variables which have significant association in all the stages which the buyers undergo while purchasing home appliances.

Shahram Jenabi, Seyed Yahya Seyed Danesh and Minoo Yousefi (2013)

made a study titled, "Examining the effect of Brand dimension (trademark) on home appliances consumers' behavior Case study: LG brand in Rasht city", tells that one of the most important and valuable assets of a company is its trademark. The more valuable is a trademark for consumers more profit the company achieves.

Janaki, P and Shanthi, P (2013) "Marketing Stimuli In Purchase Of Home Appliances From Customer Perspectives", International Journal of Sales & Marketing Management Research and Development (IJSMMRD), Vol. 3, Issue 2, pp. 23-30.

Shahram Jenabi, Seyed Yahya Seyed Danesh and Minoo Yousefi (2013) "Examining the effect of Brand dimension (trademark) on home appliances consumers' behavior Case study: LG brand in Rasht city", International Research Journal of Applied and Basic Sciences, Vol.4, Issue.7, pp.1894-1900

DATA ANALYSIS AND INTERPRETATION

The data collected from the samples have systematically applied and presented in the tables under various headings in the following pages. They were also arranged in such a way that, a detailed analysis can; be made so as to present suitable interpretation for the same. The data have been analyzed using the following statistical tools.

- Percentage analysis
- Likert scale analysis

PERCENTAGE ANALYSIS

The percentage analysis is mainly used to specify the number of respondents in the sample falling in each category. Further, it is also used as a standard for comparison purpose. A number of respondents distribution shows the number of frequencies in various classes, which helps to get preliminary idea with respect to objectives under study. To interpret the results comprehensively percentage value are computed.

**FORMULA PERCENTAGE =**

$$\frac{\text{Number of respondents}}{\text{Total number of respondents}} * 100$$

TABLE NO: 1
GENDER OF THE RESPONDENTS

Sl.NO	Gender	NO. OF. RESPONDENT	PERCENTAGE
1	MALE	50	41%
2	FEMALE	72	59%
	TOTAL	120	100

INTERPRRETATION

The above table shows that Gender of the respondents.

Out of total 120 respondents, 41% of the respondents are male and 59% of the respondents are female.

TABLE SHOWING THAT WHICH THE RESPONDENTS LIKES

S. NO	PARTICULARS	RESPONDENTS	PERCENTAGE
1	Washing machine	52	37%
2	Television	45	32%
3	Refrigerator	35	25%
4	Mobile phones	8	6%
	TOTAL	140	100

ITERPRRETATION

According to the respondents, 37% of the respondents likes washing machine, 32% of the respondents likes television, 25% of the respondents likes refrigerator, 6% of the respondents likes mobile phones. **Majority (37%) of the respondents likes the Washing machine.**

LIKERT SCALE ANALYSIS

A Likert scale analysis is a method of meaning attitude. Ordinal scale of responses to a question or statement, ordered in hierarchical from strongly negative to strongly positive. Used mainly in behavioural science, in likert's method a person's attitude is measured by combining (additional or averaging) their responses all items

FORMULA

$$\text{Likert scale} = \frac{\sum (FX)}{\text{Total number of respondents}}$$

F = Number of Respondents
X = Likert Scale Value
(FX) = Total Scale

**TABLE SHOWING THE OPINION OF THE RESPONDENTS TOWARDS THE SERVICE**

S.NO	PARTICULARS	RESPONDENTS	LIKERT SCALE	TOTAL SCORE
1	Excellent	44	5	220
2	Good	58	4	232
3	Average	23	3	69
4	Poor	5	2	10
5	Very poor	10	1	10
	TOTAL	140		541

Likert Value= $\frac{fx}{no. \text{ of respondents}}$
 $= \frac{541}{140}$
 $= 3.8$

INTERPRETATION

The table shows that 44 respondents are excellent, 58 are

good, 23 are average, 5 are poor, 10 are poor.

TABLE SHOWING THE OPINION OF THE RESPONDENTS TOWARDS PRICE OF LG PRODUCT

S.N O	PARTICULARS	RESPONDENTS	LIKERT SCALE	TOTAL SCORE
1	Excellent	55	5	275
2	Good	60	4	240
3	Average	22	3	66
4	Poor	0	2	0
5	Very poor	3	1	3
	TOTAL	140		584

Likert scale value : $\frac{\sum(FX)}{\text{total number of respondents}}$
 $= \frac{584}{140}$
 $= 4.1$

INTERPRETATION

The table showing that 55 excellent, 60 are good, 22 are average, 0 are poor, 3 are very poor.

Likert scale value is greater than the mid value, so the respondents are satisfied with the price of the LG product.

FINDINGS, SUGGESTIONS AND CONCLUSION**FINDING**

- Majority (66%) of the respondents are from the age group of below of 25years.
- Majority (68%) of the respondents are unmarried.
- Majority (62%) of the respondents are under graduate.
- Majority (42%) of the respondents are private

employees.

- Majority (52%) of the respondent's annual income are below Rs. 150000.
- Majority (59%) respondents are living as a joint family.
- Majority (37%) of the respondents likes to buy washing machine .
- Majority (64%) of the respondents prefer to buy their product from showrooms .
- Majority (66%) of respondents said that the price is affordable .
- Majority (38%) of the respondents got awareness about the product by advertisements.
- Majority (38%) of the respondents are been the customer of the LG product for 1-2 years.



- Majority (44%) of respondents said that the quality factor made them to buy the LG product.
- Majority (34%) of the respondent's buying decision are been influenced by chief wage earner.
- Majority (56%) of the respondent rates their experience of using the LG product as good.
- Majority (52%) of the respondents agrees that the brand name influences their purchase.
- Maximum respondent said that the satisfaction level towards the price, brand, quality, design and service are good.

Investyadnya.in. Retrieved 20 December 2018.

WEBSITES

1. www.wikipedia.com
2. Engadget.com
3. Mobigyaan.com
4. Lg.com

SUGGESTIONS

From this survey we found that:

- Majority of the customers prefers to use washing machine so the level of sales volume can increase by launching showrooms in Center of towns and in Rural areas.
- By introducing new offers to reputed customers, they can increase the sales level of business.
- The quality of service in showrooms would be increase, so the pessimistic level for customer can be huge.
- Advertisement of this product can be increase to reach in wide range of customer.

CONCLUSION

The study is about analysing the customer satisfaction towards LG products and for this study a sample of 140 was collected from the respondents and percentage analysis and chi square were used as tools to analyse the data the conclusion is that variety and service should be increased so that the sales volume can be increased in the future period of time. If the suggestions given by the respondent regarding LG product implemented by the company, the sales volume of the LG product and growth of the company will be improved.

REFERENCE

1. "LG overview". LG corp. Archived from [the original](#) on 23 June 2013. Retrieved 7 April 2013.
2. Song, Su-hyun. "LG founder bequeaths principle of harmony, sustainable growth". [The Krea Herald](#).
3. [comScore Reports October 2012 U.S. Mobile Subscriber Market Share - comScore, Inc. Comscore.com \(2012-11-30\). Retrieved on 2013-07-12. . LG Electronics. Retrieved 20 August 2013.](#)
4. "LG Logo: Design and History". [FamousLogos.net](#). Retrieved 12 October 2011.
5. "Consumer Durable Sector Analysis | Top 8 Consumer Products Companies In India".



A STUDY ON INFLUENCE OF ADVERTISING ON BRAND AWARENESS AND CONSUMER'S PREFERENCE TOWARDS KALYAN JEWELLERS SHOWROOM (COIMBATORE)

Dr. D. Sivasakthi

*Associate Professor, Department of Commerce with Professional Accounting,
Dr. N.G.P. Arts and Science College, Coimbatore*

Ananya.N

*Student of III B.Com(PA), Department of Commerce with Professional Accounting,
Dr.N.G.P Arts and Science College, Coimbatore*

ABSTRACT

Advertising is a marketing communication that employees an openly sponsored, non-personal message to promote or sell a product, service or idea. Sponsors of advertising are typically businesses wishing to promote their product or service. Advertising is differentiated from public relations in that an advertiser phase for and has control over the message. It differs from personal selling in that the message is non-personal i.e., not directed to a particular individual. Advertising is communicated through various mass Medias, including traditional media such as newspaper, magazines, television, radio, outdoor advertising, or direct mail, and new media such as search results, blogs, social media, websites and text messages. The actual presentation of the message in a medium is referred to as an advertisement, or “ad” or advert for short.

Commercial advertisement often seeks to generate increased consumptions of their products or services through “branding”, which associates a product name or image with certain qualities in the minds of consumers. On the other hand, ads that intend to elicit an immediate sale are known as direct response advertising. Non-commercial entities that advertise more than consumer products or services include political parties, interest groups, religious organizations and governmental agencies. Non-profit organizations may use free modes of persuasion, such as a public service announcement. Advertising may also help to reassure employees or shareholders that a company is viable or successful.

INTRODUCTION

Modern advertising organized with the techniques introduced with tobacco advertising in the 1920s, most significantly with the campaigns of EDWARD BERNAYS, considered the founder of modern, “Madison’s avenue” advertising.

Worldwide spending on advertising in 2015 amounted to an estimated US\$529.43billion. Advertising projected of distribution for 2017 was 40.4% on television, 33.3%on digital, 9% on newspapers, 6.9%on magazines, 5.8% outdoors and 4.3% on radios. Internationally, the largest (“BIG FIVE”) advertising agency groups are dents; inter public, Omnicom, Publics, and WPP.

It won't be wrong to say “world is under brand bombardment”. A physical product is only a part of a production. It cannot before the potential buyers. Advertising is considered as a major and important for economic growth of the marketer’s products without which the process of BRANDING is impossible. Branding is crucial aims of advertising which a particular brand of product or service earn loyalty from the consumers. Consumer preference is actually an emotional reaction which is developed after the advertising. Advertising plays a major role in developing and sustaining brand equity.



STATEMENT OF THE PROBLEM

Competition is very common among the today's marketplace. Marketing is based on selling the brand which can be differentiated and nowadays consumer celebrities as their hero's and role models. The people place their extreme trust in the words of celebrities more than the marketers. Each and every product are needed to have its own advertisement to distinguish themselves from the competitors because advertisement is considered to be a crucial tool in building a brand image of product or service

SCOPE OF THE STUDY

This study is taken to analyze the effect of attractive advertisement with various region film industry celebrities in increasing the consumer preference of products and creating strong brand image and loyalty towards Kalyan jewelers. The study also focuses the consumers' change of taste and preference after getting attracted to advertisements and promise of their well-known actors and actresses.

OBJECTIVES OF THE STUDY

- To study the impact of advertising on brand awareness.
- To study the impact of other factors in brand preference of jeweler's showrooms.
- To study relationships between brand awareness and its impact on consumer preference.
- To analyze the role of advertising in building strong loyalty of consumers towards the branding.

RESEARCH DESIGN

Research design is a set of methods and procedures used in collecting and analyzing the measures of variables specified in research problem.

REVIEW OF LITERATURE

Sanjula (2017)¹ found out in her study that women are becoming aware of the branded jewellery and they believe that it products for various exploitations. Now a day's women are giving preference to branded jewellery.

K Prabha kumari and M Anita (2016)² in their study "A study on consumer preferences towards world jewellery shop in erode city" reveals that the spending power of the consumer may diverge from one to one another based and demographic

The study type used for the study and analysis is the descriptive methods of study. A study aimed o find out the influences of advertising in building brand image and effecting the consumers buying behaviors of gold and other ornament jewelries.

SAMPLING METHOD

A convenient sampling technique tool was adopted for data collection.

DATA COLLECTION

Both primary and secondary data are to be collected for the study. Primary data will be collected from the respondents using structured questionnaires. Secondary will be text book, WebPages, articles, journals, magazines etc.,

SAMPLE SIZE

The study consists of 120 respondents chosen from Coimbatore city.

AREA OF STUDY

The city of Coimbatore is selected for location of a study.

TOOLS FOR ANALYSIS

- Simple percentage analysis
- Ranking analysis
- Liker scale analysis

LIMITATION

- The study is only carried out only in Coimbatore city.
- The sample size taken for the study is limited only to 120 respondents.
- Findings of the study or purely depending on response of the respondents .

physiological factors in the order to generate buying behaviour the shoppers have to offer schemes as per the spending power of the consumers.

Priyanka Gautam and Urmila Thakur (2015)³ , in the study, " A study on consumer preferences among branded and non branded jewellery " , reveals that brand image is a significance factor which influences the consumers buying behaviours, so jewellers should maintain their good image in market. Also the level of contentment that the population has for branded jewellery superior then the non branded jewellery so making branded jewellery is more popular.

**ANALYSIS AND INTERPRETATION
PERCENTAGE ANALYSIS**

The data gathered for the study is also presented in terms of percentage. The percentages are calculated to the total of the subject. The processed data was analyzed and interpreted in the chapter analysis and interpretation.

**FORMULA:
PERCENTAGE=**

$$\frac{\text{Number of respondents}}{\text{Total number of respondents}} * 100$$

What makes Kalyan jewelers unique from other jewellers

S. No	Factors	No of respondents	Percentage
1	Best quality	46	38.3%
2	Attractive advertisement	30	25.0%
3	Assurance from celebrities	15	12.5%
4	Attractive designs	17	14.2%
5	Brand image	12	10.0%
	Total	120	100%

INTERPRETATION

The above table indicates that 38.3% of respondents says that the kalyan jewelers are best in quality, 25.0% of respondents are chooses kalyan jewellery for attractive advetisments, 12.5% of the respondents chooses the kalyan jewelers for attractive assurance from celebrities, 14.2% of the respondents chooses kalyan jewelers for attractive designs and 10.0% of the respondents chooses kalyan jewelry for brand image.

Most of the respondents prefer kalyan jewelers for best quality (38.3%).

Table shows that how frequently do the customers purchase the jewel

S. No	Factor	No of respondents	Percentage
1	Once in a month	16	40.8%
2	Once in every 6 month	13	35%
3	Once in a year	42	10.8%
4	Less often	49	13.3%
	TOTAL	120	100%

INTERPRETATION

The above table shows that 40.8% of the respondents buy the jewel once in the month, 35% of the respondents buy the jewel once in every 6 month, 10.8% of the respondents buy the jewel once in a year and 13.3% of the respondents buy the jewel less often.

Most of the respondents purchase the jewel once in the month (40.8%).

LIKERT SCALE ANALYSIS

Likert scale are a common ratings format for surveys. Respondents rank quality from high to low are best to worst using five or seven levels. Likert items are used to measure respondents attitudes to a particular question or statement. Ordered in hierarchical sequence from strongly positive. Used mainly in behavioural science, in likert's method a person's attitude is measured by combining (adding or averaging) their responses all items.

FORMULA:

$$\text{Likert scale} = \frac{\sum(fx)}{\text{Total number of respondents}}$$

While ,

f =Number of respondents

x =Likert scale value

E(fx) =Total score

**Mid value**

Mid value indicates the middle most value of likert scale.

$$\begin{aligned} \text{Likert scale: } & \sum (fx) / \text{total number of respondents} \\ & = 463 / 120 \\ & = 3.8 \end{aligned}$$

s.no	Particulars	No. of respondents	Likert scale	Total score
1	Strongly agree	22	5	110
2	Agree	66	4	264
3	Neutral	27	3	81
4	Disagree	3	2	6
5	Strongly disagree	2	1	2
	TOTAL	120		463

INTERPRETATION

From the above table, the design and quality of jewels is capable in attracting the customers shows in the likert scale value is 3.8 which is greater than the mid value (3)

Hence, the customers agree with the design and quality of jewels.

FINDINGS, SUGGESTIONS AND CONCLUSION**FINDINGS FOR PERCENTAGE ANALYSIS:**

- Majority (60.8%) of the respondents are female.
- Majority (59.3%) of the respondents belongs to the age category of 20-35 years.
- Majority (80.8%) of the respondents are unmarried.
- Majority (63.3%) of the respondents belongs to the nuclear family.
- Majority (79.2%) of the respondent's family consists of 3-5 members.
- Majority (53.3%) of the customers are from urban areas.
- Majority (60%) of the respondents are students.
- Majority (74.2%) of the respondents gets monthly income below Rs.25000.
- Majority (75%) of the respondents are came to know by advertisements.
- Majority (38.3%) of the respondents prefer kalyan jewelers for best quality.
- Majority (59.3%) of the respondents are not operating the business outside the country.
- Majority (58.3%) of the respondents agrees that advertisement is crucial in increasing the sales.
- Majority (59.2%) of the respondents strongly agree that advertising using celebrities is vital in enhancing the brand image of the organization.
- Majority (40.8%) of the respondents purchase the jewel once in the month.

FINDINGS FOR LIKERT SCALE ANALYSIS:

- Hence the customers agree that the design and quality of jewels is capable for attracting.

- Hence the customers agree that besides quality advertisement is crucial in increasing sales.
- Hence the customers agree advertisement using celebrities enhance the brand image.

SUGGESTIONS

- Females are the dominant consumers of jewel industry. So the kalyan jewellers must concentrate further more in a way of attracting and satisfying the taste and preference of the ladies.
- The study suggested that the consumers gets awareness through advertisement so, the advertisement has to be modulated according to the preference of the consumers.
- Most of the respondents prefer gold, so kalyan should avail more designs in gold jeweler.
- Kalyan jewelers can bring more offers and schemes for the customers.

CONCLUSION

Celebrity advertising helps in enhancing the brand loyalty and sales of the product or organisation. Today the choices and tastes of the civilians have become wide and large. An efficiency of the jewellery showrooms is proved only it has the capability to attract the customers and satisfy their demand. Kalyan jewelers has its own brand name in the market with excellent advertising and producing the quality products.

REFERENCE

1. Research methodology written by C.R. Kothari
2. Advertising (influence and persuasion) written by Clive Glifford

Websites

1. www.shodhganga.inflibnet.ac.in
2. www.internationaljournalsrg.org
3. www.researchgate.net



Journal reference

1. Sanjula,N.C – “ the study on consumer perception of branded jewellery in india.
2. Kumari,P.K.,anitha,M. “that a study on consumer preference towards gold jewellery shop”.
3. Goutham,P.,Thakur,U.,-“ a study on consumer preference among branded and non branded jewellery”.
4. Sultana,M.,Siddique , J.C., ISL



A STUDY ON A BRAND LOYALTY AND CONSUMER PREFERENCE TOWARDS APPLE IPHONE WITH SPECIAL REFERENCE TO COIMBATORE CITY

Nandhini.M

*Student of III B.Com.(PA), Department of Commerce with Professional Accounting,
Dr. N. G. P Arts and Science College, Coimbatore*

Dr. K.Vanaja

*Head of the Department, Department of Commerce with Professional Accounting,
Dr. N. G. P Arts and Science College, Coimbatore*

ABSTRACT

Smart phones are popular among young generation especially college students. Majority of the students have smart phones in their hand. This study aims to find out the preference of smart phones among college students in Salem city. The main objective of the study is to concentrate deeply on the various features that affect the students to prefer a particular smart phone. The population for this research was college students in the Salem city and according to the convenience of the researcher to reach the students convenience sampling method was adopted. A constructive questionnaire was framed and variables such as demographic, technical attributes, features in the smart phones were included. This was used to collect the primary data from the respondents and secondary data were also used for this study. Statistical tools such as descriptive analysis and chi-square test were used.

KEYWORDS : *Brand preference, Brand Loyalty, Features, Satisfaction.*

INTRODUCTION

Brand loyalty is the favor given by a consumer in order to buy a specific brand in a particular product category. Consumer who give a type of preference for a brand, have the following mindset: "I am committed to this brand", "I am willing today a higher price for this brand over other brands" and "I will recommend this brand to other" ' (Giddiness, 2002). A good loyalty can lead to various and numerous benefits such as an improved market share, lower marketing cost and improved opportunities for brand extension (Martin Evans, 2006). The amount of money that consumers will spend on various brands in different product categories would change from one customer to another one but one thing that remains constant is that each brand evokes set of positive feelings for the consumer such as confident,

young, stylish etc. As a consequence of this, nowadays it is vital for the brand to do more than just satisfy a need or service. It must create and be able to maintain an emotional connection with its customers. By inducing positive feelings among them, the customers will keep.

STATEMENT OF THE PROBLEM

This research has been conducted to identify the effect of brand quality, Perceived Brand Quality, Customer Satisfaction, and Brand Image on customer's brand loyalty. As there is a war of technology going on in this era of generation there are a lot of substitutes are available in the market, this research will help to understand how to keep customers loyal and understand the customer preferences. There is a need to



identify the relation of Perceived Brand Quality, Customer Satisfaction, and Brand Image with customer's brand loyalty.

SCOPE OF THE STUDY

Since the mid-1990s, the mobile phone industry has sought widespread adoption of mobile data services, envisioning a new "mobile Internet" with its own complex value network delivered through Smartphone terminals. With its iPhone, Apple rapidly gained Smartphone market share while spurring widespread adoption of mobile data services in Coimbatore.

OBJECTIVES OF THE STUDY

- To promote level of customer awareness towards apple iPhone
- To find out the factors which influence to purchase of apple iPhone
- To study the relationship between customer behaviour and brand loyalty
- To know the problems faced by apple iPhone to promote brand loyalty in market.
- To offer better suggestion based on the result of study.

TOOLS FOR ANALYSIS

The primary data were coded, classified, tabulated and analysed. The statistical tools used for analysis of the study are:

- Simple percentage Analysis
- Ranking Correlation
- Chi-square Analysis

LIMITATION OF THE STUDY

- The survey was limited to Coimbatore city only, so it cannot be generalized to all the centres.
- The sample size is limited to 125 due to time constraint.
- Time is one of the major limitations.

REVIEW OF LITERATURE

Noor-UI-Ain Nawaz and Ahmad Usman (2011)" in their study "What Makes Customers Brand Loyal: A Study on Telecommunication Sector of

Pakistan" found that. The Study is focus on loyalty concept in services sector. Brand loyalty It receiving great deal of attention in telecommunication sector. Since quality, satisfaction, commitment and trust are major antecedents of brand loyalty for telecommunication sector and for other similar markets.

Jessy John (2011) in his study "An analysis on the customer loyalty III telecom sector: Special reference to Bharath Sanchar Nigam limited, India" concluded that, the purpose of this paper was to Investigate the factors that influence customer loyalty of BSNL customers. Even though the name provided by BSNL is very cost effective it is still losing its customer base.

Sivarthina Mohan. R and Manganathan.(2011) at their study "Conceptual framework of Mobile Marketing : Spamming the consumer around the world" found that, Mobile phones can also be an extremely cost effective communication channel well as an efficient way of delivering a marketing message. Promotion through mobiles has emerged as an integral part of any brand's marketing campaign today.

DATA ANALYSIS AND INTERPRETATION

In this chapter the analysis and interpretation of "A study on a brand loyalty and consumer preference towards apple iPhone with special reference to Coimbatore city", is presented based on the opinion of samples of 125 respondents selected from Coimbatore city through a questionnaire containing 20 questions. These were analysed through three different tools and they are as follows,

- Simple Percentage analysis
- Rank Correlation
- Chi-square Analysis

SIMPLE PERCENTAGE ANALYSIS

Simple percentage analysis is the method to represent raw streams of data as a percentage for better understanding of collected data. Percentage analysis is applied to create a contingency table from the frequency distribution and represent the collected data for better understanding.

**FORMULA:**

$$\text{Percentage} = \frac{\text{Number of respondents}}{\text{Total no. of respondents}} \times 100$$

TABLE 1
TABLE SHOWING THE GENDER OF THE RESPONDENTS

GENDER	NO OF RESPONDENTS	PERCENTAGE (%)
MALE	62	49.6
FEMALE	63	50.4
TOTAL	125	100

(Source: Primary data)

INTERPRETATION

From the above table it is clear that out of 125 sample respondents 49.6% are male and 50.4% of respondents are female.

Majority, 50.4% of female respondent

TABLE 2
TABLE SHOWING THE EDUCATIONAL QUALIFICATION OF THE RESPONDENTS

EDUCATIONAL LEVEL	NO OF RESPONDENTS	PERCENTAGE (%)
HIGHER SECONDARY	25	20
UG	76	60.8
PG	15	12
OTHER	9	7.2
TOTAL	125	100

(Source: Primary data)

INTERPRETATION

From the table it is clear that out of 125 respondents 20% of the respondents are higher

secondary, 60.8% of the respondents are UG, 12% of the respondents are PG, 7.2% are others. Majority, 60.8 % of the respondents are under graduates.

TABLE 3
TABLE SHOWING THE OCCUPATIONAL STATUS OF THE RESPONDENTS

OCCUPATION	NO OF THE RESPONDENTS	PERCENTAGE (%)
SELF EMPLOYED	22	17.6
SALARIED	49	39.2
OTHERS	54	43.2
TOTAL	125	100

INTERPRETATION

From the above table it is clear that out of 125 respondents 17.6% of the respondents are self employed, 39.2% of the respondents are salaried, 43.2% are others.

Majority, 43.2% of the respondents are others.

RANK CORRELATION

A rank analysis is any of several statistics that measure an ordinal association, the relationship between ranking of different ordinal variables or different ranking of the same variables, where a "ranking" is the assignment of the labels "first", "second", "third", etc., To different observation of a particular variable. A rank analysis measures of similarity between two rankings, and can be used to assess the significance of the relation between them.



It is not necessarily a total order of object because two different objects can have the same ranking. The

ranking themselves are totally ordered.

TABLE 4
TABLE SHOWING THE FACTORS INFLUENCE THE RESPONDENTS TO SELECT APPLE IPHONES

FACTORS	I (8)	II (7)	III (6)	IV (5)	V (4)	VI (3)	VII (2)	VIII (1)	TOTAL	RANK
BRAND	53 (424)	33 (231)	14 (84)	8 (40)	7 (28)	7 (21)	3 (6)	0 (0)	834	I
BATTERY LIFE	21 (168)	26 (182)	37 (222)	15 (75)	7 (28)	9 (27)	8 (16)	2 (2)	720	II
DURABILITY	9 (72)	8 (56)	10 (60)	29 (145)	25 (100)	24 (72)	19 (38)	1 (1)	544	IV
SOUND QUALITY	7 (56)	8 (56)	17 (102)	29 (145)	19 (76)	20 (60)	21 (42)	4 (4)	541	V
CAMERA & MUSIC	6 (48)	11 (77)	15 (90)	6 (30)	25 (100)	35 (105)	22 (44)	5 (5)	499	VII
DISPLAY	9 (72)	8 (56)	11 (66)	19 (95)	26 (104)	18 (54)	31 (62)	3 (3)	512	VI
FEATURES	19 (152)	31 (217)	16 (96)	14 (70)	12 (48)	7 (21)	16 (32)	10 (10)	646	III
CELEBRITY ENDORSEMENT	1 (8)	0 (0)	5 (30)	5 (25)	4 (16)	5 (15)	5 (10)	100 (100)	204	VIII

INTERPRETATION

It is observed that, the factors influence the respondents to select smart phones all scored as follows Brand with the score of (834), Battery life with the score of (720), Durability with the score of (544), Sound Quality with the score of (541), Camera & Music with the score of (499), Display with the score of (512), Features with the score of (646), Celebrity Endorsement (204).

Hence, it is proved that BRAND is the main factor that influences the respondents to select Apple iPhones.

CHI-SQUARE ANALYSIS

A statistical test used to determine the probability of obtaining the observed by chance, under a specific hypothesis. It is used to test if the standard deviation of a population is equal to the specific value. Chi-square is a statistical significance test based on frequency of occurrence; it is applicable both qualitative and quantitative variables. Among its

many uses, the most common are tests of hypothesized probabilities or probability distributions, statistical dependence or independence and common population. A chi-square is any statistical hypothesis test in which the test statistics has a chi-square distribution if the null hypothesis is true.

FORMULA

$$\chi^2 = (O-E)^2 / E$$

O= Observed frequency

E= Expected frequency

DEGREE OF FREEDOM

$$V=(r-1)(c-1)$$

TABLE 5

Relationship between the gender of the respondents and which factors does the respondents select while purchasing the appleiphones

**Hypothesis:**

Gender	Brand	Battery life	durability	Sound quality	Camera & Music	Display	features	total
Male	8	12	3	5	2	2	30	62
Female	11	12	3	3	6	2	26	63
Total	19	24	6	8	8	4	56	125

There is no significant between gender of the respondents and the factors selected by the respondents while purchasing the apple iphone.

To find out the association between gender and the factors selected by the respondents while purchasing the apple iphone, chi-square test is used and result is given below.

TABLE 5.1
Chi-Square Test

Calculated value	Degree of Freedom	Table Value	Result
3.252	6	18.548	accepted

INTERPRETATION

The calculated value of chi-square at 5% level of significance is lower than the table value. Hence the hypothesis is accepted so, there is no relationship between gender and the factors selected by respondents while purchasing the Appleiphones.

FINDINGS, SUGGESTIONS AND CONCLUSION**FINDINGS****SIMPLE PERCENTAGE ANALYSIS**

- Majority, 62.4% of the respondents have selected may be for buying the same brand of Apple iphone Majority 33.6% of the respondents are between 20-24 years.
- Majority, 50.4% of female respondents.
- Majority, 43.2% of the respondents are others.
- Majority, 32.8% of the respondents are having monthly income Rs.35001 & above.
- Majority, 60.8 % of the respondents are under graduates
- Majority, 52.8 % of the respondents are using iphone 7plus.
- Majority, 69.6% of the respondents are spending 4 hours and above on Apple iphones.
- Majority, 84.8% of the respondents have selected no.
- Majority, 52.8% are using Apple iphones for more than 4 years.
- Majority, 38.4% of the respondents like Apple iphone 6s and other Apple iphones advertisement.
- Majority, 64.8% of the sample respondents are satisfied with the brand of the Apple iphone.

- in the future.
- Majority, 77.6% of the respondents have selected the factor better features.
- Majority, 52.8% of the respondents have selected self.
- Majority, 41.6% of the respondents prefers Apple iphone 7 plus.
- Majority, 44.8% of the respondents have preferred features.
- Majority, 49.6% of the respondents have selected Rs.21000-Rs.40000.
- Majority, 88% of the respondents have selected yes (i.e.) have got satisfied with the current Appleiphone they are using.
- Majority, 63.2% of the sample respondents have satisfied.

RANKING ANALYSIS

The factors that influence the respondents to select the Apple iphones

- Brand placed on I Rank
- Battery life placed on II Rank
- Features placed on III Rank
- Durability placed on IV Rank
- Sound quality placed on V Rank
- Display placed on VI Rank
- Camera & Music placed on VII Rank
- Celebrity Endorsement placed on VIII Rank

CHI-SQUARE

The calculated value of chi-square at 5% level of significance is lower than the table value. Hence the



hypothesis is accepted so, there is no relationship between gender and the factors selected by respondents while purchasing the Apple iphones.

The calculated value of chi-square at 5% level of significant is higher than the table value. Hence hypothesis is rejected there is relationship between occupation and factors selected by the respondents while purchasing Appleiphone.

SUGGESTIONS

They wide scope for further development Apple iphones. The world of the smart phone field is not static, it is always subject to change the technology to keep abstracted of the technological improvement and the Appleiphone may need refinement.

- They should get the feedback report from the customer in order to fulfil customers' needs and wants.
- They should increase the battery backup.
- They should reduce the price in order to gain more customers and to beat their competitors.
- They should provide lot of new models to beat their competitors.
- It is suggested that faced same software of using all Appleiphones.
- It improves the after sales service.

CONCLUSION

This study is conducted from Coimbatore city, Apple iphones is a highly moving product, when compared to all other ordinary phones the study about various aspects of customer satisfaction on Apple iphone in Coimbatore city satisfied the following objectives,

- New technology in Apple iphones
- The quality of service provider in Apple iphones
- The application, brand name and price of Appleiphones etc..,

The survey conducted from Coimbatore city helps to make identification over is strength and weakness of Apple iphones.

REFERENCE

1. *Noor-Ul-Ain Nawaz and Ahmad Usman (2011), "What Makes Customers Brand Loyal: A Study on Telecommunication Sector of Pakistan" International Journal of Business and Social sciences*
2. *Jessy John (2011), "An analysis on the customer loyalty III telecom sector: Special reference to Bharath Sanchar Nigam limited", India International journal of Management Technology.*

3. *Sivarthina Mohan. R and Manganathan.(2011), "Conceptual framework of Mobile Marketing : Spamming the consumer around the world" Journal of Social and Administrative science.*



A STUDY ON CUSTOMER PREFERENCE TOWARDS HATSUN MILK PRODUCTS WITH SPECIAL REFERENCE TO COIMBATORE CITY

Dr. K. Vanaja

*Professor and Head of the Department, Department of Commerce with Professional Accounting,
Dr. N.G.P. Arts and Science College, Coimbatore*

Reshma.A.L

*Student of III B.Com.(PA), Department of Commerce with Professional Accounting,
Dr.N.G.P Arts and Science College, Coimbatore*

ABSTRACT

The company sells its milk, ice cream, and other goods during its 2500 odd hatsun daily retail cum distribution points. The sales collections are also credited to hatsun bank account on each day. Whether it is a farmers, distributors, transporters or employees, we don't make or take expenses in cash. The grouping is by bank transfers" says Chandramogan the move to make payments to farmers bank accounts was the real challenge in the institution. Even the district level dairy unions allied to the Gujarat corporative milk marketing federation (Amul) currently border bank transfers to the accounts of primary village society, which in turn, casing out their farmers in cash. There was no effect on sales either.

"The required going a step ahead and reaching farmer directly. Its begin the exercise in October 2013 and by 2014 end, 90% of our farmers were covered. Initially, they were reluctant, being used to getting cash. But they were firm with them, since it was a logistical nightmare to assemble for cash and express this to each of our 9800 procurement centers. And it was even more difficult to create exact expenses to each cultivator against varing volumes and fat satisfied of milk supplied", says Chandramogan. When farmers say money actually coming to their bank accounts, the state changed.



INTRODUCTION

Definition of customer

- A person, business or other entity which buys goods and services produced by another person, company or other entity.
- One who regularly or repeatedly makes purchases of a trader, a purchase a buyer?

MEANING OF CUSTOMER

PREFERENCE

Customer preference is the study of how citizens buy, what they buy, when they buy and why they buy, It blends elements from psychology, sociology, anthropology and economic. It attempts to understand the buyer decision making process, both individually and in groups. It studies uniqueness of individual customers such as demographics, psychographics and preference variables in an attempt to understand people wants. It also tries to assess influence on the customer from groups such as family, friends, reference group, and society in general. The process of consumption has long been connected with sex and general, it comes as no surprise that customer researches often inspects the effects of these variables on customer preferences.

The term customer preference is clear as the preference that customer display in searching for purchase, using, evaluating and disposing of products and services that they expect will please their wants. Customer preference focuses on how individual make decision to spend their available property (time, money, effort) on consumption consistent items. It includes what they buy, why they buy, where they buy, how often they buy for purchase and the impact of such evaluation on future purchases, and how they dispose.

MEANING OF PERCEPTION

The ability to see hears or become aware of something through the senses. To understand in sequence and give important to what object approximately us. Perception is the process by which we organize and select information received through the mind and give significance to the objects in the world around us. This is done by our brain. We do not forever do this correctly.

Definition of customer satisfaction

According to Harold E Edmondson "Customer satisfaction" is defined as " the number of customers, or percentage of total customers , whose reported experience with a firm , its products , or its service (ratings) exceeds particular contract goals".

Customer satisfaction is defined by whether the customer chooses to do business with you or your brand in the future. Many factors play a role in purchaser satisfaction, including customer service, creation excellence and the ease of doing business. Company must consider customer approval as a significant role in the natural existence value of the customer.

Customer satisfaction, a term regularly used in marketing, is determined of how products and services supplied by a company meet are surplus customer anticipation. In a review nearly 200 older advertising managers, 71% respond that they found a customer fulfilment metric very useful in organisation and monitor their businesses.

Advantage of customer satisfaction

Purchase comments, suggestions and reply about a company's products, business practice and customer examine point of orientation are one of the biggest advantages of customer comment surveys. Serious input and answer can help a corporation to develop healthier customer relation programs.

Disadvantages of customer satisfaction

Customer response surveys and questionnaires can sometimes be too scientific and methodical to control to compassionate instinct and traits of customer. Exact analysis and interpretation of response and answers provided by customers might not provide the right kind insights that business not to better serve customer.

Importance of customer satisfaction

Sales are the most significant goal of any commercial enterprise. It becomes necessary to persuade customer for customer satisfaction it is necessary to establish and maintain certain important characteristics like:

- a) Quality
- b) Fair prizes
- c) Efficient delivery
- d) Good customer handling skills
- e) Serious consideration of customer complaints

Satisfaction is the reaction of pleasure or disappointment attained from comparing a product apparent show (outcome) in relation to his or her expectations. The customer is dissatisfied. If the performance matches the belief, the customer satisfied. If the performance exceeds outlook the customer is highly satisfied.

STATEMENT OF THE PROBLEM

The customer is always right. Customer belongs at the heart of every business becomes without them there is no business. Without their money, there is



no exchange. Therefore for any company, the customer is the primary point that control very progress. Marketing is based on this logic. It is processed by which a company finds out what its customers wants and needs, and then delivery it in a way that makes as much profit as possible.

The study is to identify the customer service towards HATSUN MILK PRODUCTS. This study focus on primary data and secondary data. This study aims towards knowing the customer opinion about the HATSUN milk products. Due to time constraints only the 250 customers of HATSUN milk products are taken as respondents. This study will help us to understand the customer satisfaction level and their expectations and their performance.

SCOPE OF THE STUDY

The scope of the study is to identify the customer performance and satisfaction of hatsun milk products in Coimbatore city only and its only considering the attitude of the local customer. This study is based on primary data and secondary data. Through the Main objective of this study extends to the following related aspects viz, brand awareness of customer about the milk products of HATSUN, customer preference and satisfaction regarding the products. To analyze the factors influencing the customer to buy the particular brand of HATSUN PRODUCT and the problem faced by the customer in purchasing and using of HATSUN milk products.

This study aims towards knowing the customer opinion about various products in HATSUN MILK PRODUCTS. This study will help us to understand the customer's satisfaction level and their performance for the hatsun milk products.

OBJECTIVES OF THE STUDY

- To identify the brand awareness of the respondents to purchase the brand of hatsun milk products.
- To assess the level of the customer preference of hatsun milk products.
- To analyses the major factors influencing in buying "HATSUN "Products.
- To study the customer satisfaction towards using hatsun milk products.
- To study the problems faced by the respondents in using hatsun milk products.

RESEARCH METHODOLOGY

Research is an academic activity which comprises of defining and redefining problems, formulating hypothesis of suggested solutions, collecting, organizing and evaluating data, making deductions and conclusions.

RESEARCH DESIGN

A research design is the understanding of conditions for collections and analysis of data in a manner that aims to combine relevant to the research purpose with economy in method. The best design on the research question as well as orientation of researcher.

Sampling Type

In this study the researcher used convenience sampling. The sample was chosen according to the convenience of the researcher. A structured questionnaire has been prepared to get the appropriate information from the respondents. The questionnaire consists of a variety of questions offered to the respondents for their despondence.

Sample size

In this study the researchers sample size is 130.

Data collection

i. Primary data

The data was collected through a questionnaire. The questions were in the form of multiple choices. The survey was adopted and the information was collected from 130 respondents.

ii. Secondary data

The data that already exists is called as secondary data. This data is collected beforehand by others. The sources are books, magazines, and any published. For the present study the secondary source are also used.

Area of the study

The study was conducted with the customers of HATSUN MILK PRODUCTS in the Coimbatore city.

Statistical tools used for analysis

- Percentage analysis
- ANOVA
- Chi-square test
- Ranking analysis
- Weighted average

REVIEW OF LITERATURE

1. Recs(1992)² conducted a study on "Factors influencing customer choice" revealed that food were flavour , texture, appearance, advertising, a reduction in traditional cooking, fragmentation of family means and an increase in "snacking"etc . Demographic and household role changes and the introduction of microwave owens had formed changes in eating habits. Vigorous sale of chilled and other equipped foods was related to the large number of operational wives and single people, who require value expediency. Development in retailing with concentration of 80.00 per cent of food sales in supermarkets was also considered to be



important. Customers were responding to messages about safety and enthusiastic drinking. They were disturbed about the way in which food was produced and want safe, “natural”, high quality food at an appropriate price.

2. Singh(1995)²conducted a study on “Factors influencing customer preferences for type of milk supply in Hissar city” examined that the milk quality, fitting, availability, a supply in quantity desired, flavour, color, freshness and mode of compensation which showed higher levels of customer satisfaction.

Dhillon(1995)²conducted a study on “Food purchase habits and customer awareness of rural and urban housewives in Dharwad” confirmed that the purchase behaviour in Ludhiana, rural and urban respondents rank nearby market(mean score of 1.47 for rural and 2.10)

DATA ANALYSIS AND INTERPRETATION

Simple Percentage Analysis

The percentage analysis is mainly used to find the distribution of different categories of respondents. As the value are expressed in terms of percentage it facilitates comparison and standardization. The Analysis describes the classification of the respondents falling under each category.

FORMULA:

$$\text{Percentage} = \frac{\text{Number of respondents}}{\text{Total number of respondents}} \times 100$$

TABLE SHOWS THE DURATION OF PURCHASE OF HATSUN MILK PRODUCT FREQUENTLY

Duration	No of Respondents	Percentage
Daily	30	26.1%
Twice in a day	33	28.7%
Occasionally	28	24.3%
Two days once	18	15.7%
Once in a week	11	7.2%
Total	120	100%

(Source: Primary data)

Interpretation

Table 4.1.8 reveals that 26.1% of the respondents purchase the product Daily, 28.7% of the respondent purchase the product Twice in a day, 24.3% of the respondents purchase the product occasionally, 15.7% of the respondents purchase the product Two days once, 7.2% of the respondent purchase the product Once in a week.

Majority (28.7%) of the respondents purchase the Hatsun milk products twice in a day.

LIKERT SCALE ANALYSIS

A likert scale analysis is a method of measuring attitudes. Ordinal scale of responses to a statement, ordered in hierarchical sequence from strongly negative to strongly positive. Used behavioral sciences and psychiatry in Likert method, a person’s attitude meet combining (adding or averaging) their responses across all items.

Formula

Likert scale = (fx) / number of respondents
 F=Number of respondents
 X=Likert scale value
 (fx) = Total score

Mid-value

Mid-value indicates the middle most value of Likert scale.

TABLE SHOWING THE OPINION ON PRICE OF THE HATSUN MILK PRODUCTS.

Factors	No of Respondents	Likert Scale Value (x)	Percentage (%)
Very High price	31	5	155
High price	26	4	104
Moderate	46	3	138
Low price	12	2	24
Very low price	5	1	5
Total	120		426

$$\text{Likert scale} = \frac{\sum (FX)}{\text{Total number of respondents}} = \frac{426}{120} = 3.5$$

INTERPRETATION

Likert scale value is 3.5 is greater than the mid value (3) so the respondents opinion on price of the hatsun milk product.



FINDINGS, SUGGESTIONS AND CONCLUSION

FINDINGS

- Majority (60.3%) of the respondents belong to the age group 18-25 years.
- Majority (77.0%) of the respondents are unmarried
- Majority 83.6% of the respondents are female.
- Majority (66.1%) of the respondents belongs to the Nuclear family.
- Majority (39.8%) of the respondents were completed under graduate.
- Majority (55.2%) of the respondents income were Below Rs.20, 000.
- Majority (34.5%) of the respondents were using Hatsun milk products for more than 1 Year.
- Majority (47%) of the respondent's sources of motivation to purchase this products by milk agent.
- Majority (40%) of the respondents make payment through cash.
- Majority (46%) of the respondents opinion on advertisement in hatsun product is very attractive.
- Majority (28.7%) of the respondents purchase the Hatsun milk products twice in a day.
- Majority (46.6%) of the respondents purchase the Hatsun milk products through Door delivery.
- Majority (28.7%) of the respondents purchase the Hatsun milk products twice in a day.
- Majority (30.4%) of the respondents make payment through cash.
- Majority (24.1%) of the respondents buy quantity of 1 liter milk daily.
- Majority (31.9%) of the respondents buy Hatsun Paneer products frequently.
- Majority (40.5%) of the respondents were attracted towards team of the advertisement.
- Majority (47.8%) of the Respondents source of awareness were milk agents.

FINDINGS OF LIKERT SCALE ANALYSIS

The respondent's opinion on price of the hatsun milk product.

SUGGESTIONS

The following recommendation is made for the improvement of customer awareness and brand preference of hatsun product in the Coimbatore city.

- The company should concentrate on various advertisement media.
- Majority of the respondents state that, only sometimes they have come across the advertisement for hatsun milk product regularly in the media. To increase awareness level. To cover the rural people and college students, more models of film or sport stars may be used in advertisement
- Packing of the hatsun milk should be given more importance in order to attract more customer.
- To reduce price and to cover more number of customer

CONCLUSION

This study was undertaken to examine the customers' perception and satisfaction towards hatsun milk products. The study also reveals that customer are satisfied with the quality of hatsun products. Hence; the research concluded that the price has significant and positive impact on customers' perception and choice in selecting hatsun products. Generally, the customer change their behavior frequently on the basis of price and quality. However the data shows the customer buy the hatsun milk for its quality and taste. It has to be point out that milk customer prefer taste over than the price. Many respondents feel the price of hatsun products is too high than other brands. If the hatsun take required steps to satisfy their customer, it creates invariant position in the mind of customers.

BOOK REFERENCES

1. *Research methodology*- C.R. KOTHARI.
2. *Statistical methodology*- S.P. GUPTA

JOURNAL REFERENCES

1. *Recs(1992)² conducted a study on "Factors influencing customer choice" revealed that food were flavour , texture, appearance, advertising, a reduction in traditional cooking, fragmentation of family means and an increase in "snacking" etc.*
2. *Singh (1995)²conducted a study on "Factors influencing customer preferences for type of milk supply in Hissar city"*
3. *Dillon (1995)²conducted a study on "Food purchase habits and customer awareness of rural and urban housewives in Dharwad"*

WEBSITES

1. [www. Taxiorg.in](http://www.Taxiorg.in)
2. [www. Studymode.in](http://www.Studymode.in)
3. [www. Google.com](http://www.Google.com)



A STUDY ON CUSTOMER SATISFACTION TOWARDS AMPERE ELECTRIC BIKE WITH SPECIAL REFERENCE TO COIMBATORE CITY

Dr. D. Sivasakthi

*Associate Professor, Department of Commerce with Professional Accounting,
Dr. N.G.P. Arts and Science College, Coimbatore*

Geethanjali.P

*Student of III B.Com (PA), Department of Commerce with Professional Accounting,
Dr.N.G.P Arts and Science College, Coimbatore*

ABSTRACT

India is the second largest producer and manufacture of Two wheelers in the world. The face of auto industry that was redefined with the invitation of fuel efficient technology is all set to see dawn of new era in two wheeler industry. Its not petrol or diesel or any other fuel, but it is electricity that has initiated a revolution in two wheeler industry in India .India two wheeler industry embraced new concept of Electric bikes and Scooters that are very popular mode of transport in the developed countries like China, America and Japan. Global warming is the major concern all over the world. Electric bikes are environment friendly as air pollution, noise pollution are much reduced. Electric bikes are battery operated vehicle with low maintenance cost and very economical also.

KEYWORDS: *Electric bike, fuel economy, Pollution.*

INTRODUCTION

The E-bikes are originated in Japan in the early 1980s. Improved battery and motor technology , component modularity ,as well as economics of scale improvements have meant E-bikes can now travel longer distances , are faster, and more affordable then ever. In the past decade more than 150 million E-bikes have been sold , the largest and most rapid uptake of alternative fuelled vehicles in the history of motorisation. The E-bikes are highly advanced with cruise control technology , theft braking system, Lock braking, International styling , keyless entry , No number plate , No licensee and a lot of other features. E bikes are easy to use, lightweight and maintenance free providing a stress free experience.

STATEMENT OF THE PROBLEM

People all over the country prefer to travel on bikes, which gives them utility and cost efficient mode for transport. When it come to electric bikes are even better than normal bikes as there is no fuel

consumption in electric bikes and in countries like India where there majority are of middle class families who cannot afford high fuel prices.

SCOPE OF THE STUDY

- The main scope of the study is to analyse the customer satisfaction towards E-bikes with respect to Coimbatore city.
- The study by ascertaining the factors that motivate end user to purchase electric bike is expected to enable respective companies to improve the services , sales promotion etc.,
- The study also aims at analysing the level of customer satisfaction with respect to the E-bikes and their dealers.

OBJECTIVES OF THE STUDY

- To study the level of the customer satisfaction for Ampere electric bikes.
- To find out the factors influencing the purchase of Ampere electric bikes.



- To develop strategies for improving sales of Ampere electric bikes.
- To analyse the problems faced by the Ampere electric bike users.

found that non availability of electric bikes is also a reason for lower market share and consumers not purchasing it.

STATISTICAL TOOL USED

- Simple Percentage Analysis
- Ranking Analysis
- Likert Scale Analysis

DATA ANALYSIS AND INTERPRETATION

The data collected from the samples have systematically applied and presented in the tables under various heading in the following pages. They were also arranged in such a way that, a detailed analysis can be made so as to present suitable interpretations for the same. The statistical tools namely

- Simple percentage analysis
- Likert scale analysis
- Ranking method

LIMITATION OF THE STUDY

- The survey is based on the respondents chosen at random from Coimbatore city. Hence the results of the study cannot be generalized.
- The sample size has been restricted to 120 respondents.
- The respondent’s views and opinions may hold good for the time being and may vary in future.

SIMPLE PERCENTAGE ANALYSIS

The percentage analysis is mainly used to specify the number of respondents in this sample falling in each category. Further, it is also used as a standard for comparison purpose.

A number of respondent’s distribution shows the number of frequencies in various classes, which helps to get preliminary ideas with respects to objectives under study. Therefore, as a first step, number of respondents for various variables under this study constructed. To interpret the results comprehensively percentage values are computed.

REVIEW OF LITERATURE

Elliotfishman, Christopher Cherry (2016) says about the E-bikes speaks to one of the quickest developing sections of the showcase. More than 31 million e-bikes was sold in 2012. China drives the world in e-bikes deals, trailed in Netherlands and Germany. The research of e bikes are in earliest stage. As e-bikes utilization keeps on developing , soo too will the requirement for the further Research.

Ashish Aggarwal (2014) says that from the research it can concluded that there is strong potential for growth in the electric vehicle industry but it will take some times in India in kickoff because Customers in India are not ready to pay the high price . Also they very much concerned about the security and quality aspects.

Bhupendra kumar verma (2011)³ in his paper sates that on the basis of this study , the following suggestions can be made to help in sales of electric bike more effective. There is need to bring more awareness of various others feature of electric bike brings to a consumer mind by providing them vouchers and literature in different regional languages. There should be free, fair , justified and honest competition amongst the various electric bike companies.

Deekshu (2008)⁴ found the most of the customers were satisfied with the mileage of the electric bikes and are convinced about the electric bike benefits and were willing to refer it to their friends. It was found that most of the customers are not satisfied with after sale service. It shows that customers are dissatisfied about their sale service. It was found maximum number of customers feel the speed of electric bike to be very low and where not satisfied with the current speed of the bikes.it was

FORMULA:

$$\text{Percentage analysis} = \frac{\text{Number of respondents}}{\text{Total number of respondents}} * 100$$

TABLE SHOWING GENDER OF THE RESPONDENTS

S.NO	PARTICULARS	NO.OF RESPONDENTS	PERCENTAGE
1	MALE	56	46.6
2	FEMALE	64	53
	TOTAL	120	100

(Source: Primary data)

INTERPRETATION

From the above table, it is revealed that the 46.6% of the respondents are Male and 53% of the respondents are Female.

Hence, Majority (53%) of the respondents are Female.

LIKERT SCALE ANALYSIS

A Likert scale is a method of measuring attitudes, ordinal scale of responses to a question or statement,



ordered in hierarchical sequence from strongly negative to strongly positive. Used mainly in behavioural science and psychiatry. In Likert's scale method, A person's attitude is measured by combining (adding or averaging) their responses across all items.

FORMULA

$$\text{Likert scale} = \frac{\sum (fx)}{\text{Total number of respondents}}$$

f = Number of respondents
x = Likert scale value
 $\sum (fx)$ = Total score

MID VALUE

Mid-value indicates the middle most value of the likert scale.

TABLE SHOWING NO OF THE RESPONDENTS ARE DO ADVERTISEMENT AFFECTS THE BUYING DECISION OF E-BIKES

S.NO	PARTICULARS	NO OF THE RESPONDENTS	LIKERTS METHOD	TOTAL SCORE
1	STRONGLY AGREE	12	5	60
2	AGREE	58	4	232
3	DISAGREE	16	3	48
4	STRONGLY DISAGREE	1	2	2
5	NEUTRAL	33	1	33
	TOTAL	120	15	375

(Source: Primary data)

FORMULA

$$\begin{aligned} \text{Likerts scale} &= \frac{\sum (fx)}{\text{total number of respondents}} \\ &= 375 / 120 \\ &= 3.125 \end{aligned}$$

INTERPRETATION

From the above table, the advertisement affects the buying decision of E-bike shows in likerts scale value is 3.1 which are greater than the mid value (3).

Hence, the customers are agree with the advertisement affects to buy the E-bike.

RANKING ANALYSIS

A Rank analysis is any of several statistics that measure an ordinal association. The relationship between ranking of different ordinal variables or different ranking of the same variable. Where a "ranking" is the assignment of the label "First", "second", "third" etc., to different observations of particular variable. A Rank analysis measure the degree of similarity two rankings, and can be used to assess the significance of the relation between them.

**TABLE SHOWING THE RANK OF THE FACTORS**

S.NO	FACTOR	RANK I	RANK II	RANK III	RANK IV	RANK V	RANK VI	RANK VII	TOTAL	RANK
1.	BRAND NAME	7(0) 0	6(1) 6	5(7) 35	4(40) 160	3(27) 81	2(30) 60	1(16) 16	358	4
2.	DESIGN	7(0) 0	6(3) 18	5(10) 50	4(45) 180	3(23) 69	2(29) 58	1(10) 10	385	2
3.	PERFORMANCE	7(0) 0	6(4) 24	5(30) 150	4(26) 104	3(19) 57	2(27) 54	1(14) 14	403	1
4.	DURABILITY	7(0) 0	6(3) 18	5(20) 100	4(16) 64	3(36) 108	2(29) 58	1(16) 16	364	3
5.	PRICE	7(3) 21	6(2) 12	5(8) 40	4(24) 96	3(31) 93	2(35) 70	1(17) 17	349	6
6.	BATTERY BACKUP	7(1) 7	6(8) 48	5(8) 40	4(19) 76	3(37) 111	2(23) 46	1(24) 24	352	5
7.	LOW WEIGHT	7(0) 0	6(9) 54	5(6) 30	4(23) 92	3(23) 69	2(23) 46	1(37) 37	328	7

*(Source : Primary data)***INTERPRETATION**

The table shows that out of 120 respondents, Performance is in the rank 1, Design is in the rank 2,

Durability is in the rank 3, Brand name is in the rank 4, Battery Backup is in the rank 5, Price is in the rank 6, Low weight is in the rank 7.

INFERENCE

This is resulted that Performance is in the rank 1 that respondents.

- Majority (40%) of the respondents are encouraged to buy only for Weight less.
- Majority (64%) of the respondents have rated Good.
- Majority (77%) of the respondents think the benefits of Ampere E-bike is Easy to drive.
- Majority (93%) of the respondents are Suggest Ampere E-bikes to their Friends.
- Majority (62%) of the customers are satisfied with the E-bike performance level of 61-80%.

FINDINGS, SUGGESTIONS AND CONCLUSION
FINDING FOR PERCENTAGE ANALYSIS

- Majority (53%) of the respondents are Female.
- Majority (30.8%) of the respondents under the age group of 19-24 years.
- Majority (56%) of the respondents are Married.
- Majority (48%) of the respondents income are Rs .2,50,001 - 4,00,000.
- Majority (63%) of the respondents are Graduate.
- Majority (28%) of the respondents are Professionals.
- Majority (64%) of the respondents are Nuclear family.
- Majority (27%) of the respondents are aware in Radio & Friends.
- Majority (37%) of the respondents Purchase decision are made by Work group.
- Majority (73%) of the respondents are seen the Advertisement.

FINDINGS FOR LIKERT SCALE ANALYSIS

- Hence, the customers are agree with the advertisement affects to buy the E-bike
- Hence, the customers are feels the price of Ampere E- bike price is Modrate.
- Hence the customers are satisfied with the Ampere E-bikes.

FINDINGS FOR RANKING ANALYSIS

- This is resulted that Performance is in the rank 1 that respondents.



SUGGESTIONS

- ✓ More Advertisement is needed for the vehicle as many people are not aware of Ampere Electric bike.
- ✓ Organize Road shows and Exhibitions to educate the people.
- ✓ Ampere E-bikes are used only for short distance because of low battery backup capacity, so manufacturers should concentrate on development to increase the capacity of Ampere E-bike.
- ✓ Want more different colours in Ampere E-bikes
- ✓ To increase the speed of Ampere E-bikes, manufacturing can consider using 300 watt power motor instead of 250 watt power which offers a maximum speed of just 25km/ph only.
- ✓ The Ampere E-bikes manufacturing companies may also consider solar energy for E-bikes that may support for long travel and reduce the charging time of the battery.
- ✓ Ampere E- bikes should concentrate on improving the features of “Smooth Driving” in case of E-bikes.

6. Cherry C., Weinert J., Ma Z. (2007)- “ A study on the environmental Impacts of Electric bikes in china”
7. Viorel Trifa ., Calin Marginean, Liviu Zarnescu (2007) - A study conducted about “ The Implementation of Electric bike used in Reluctant motors”.
8. Chris Cherry and Robert Cervero (2006) – The study on “Use characteristics and mode choice behaviour of electric bikes in China”
9. Viorel Trifa, Calin Marginean , Liviu Zarnescu (2006) – A study on “The Implementation of an Electric bike using Reluctant Motors”
10. Jonathan X. Weinert and Chaktan MA (2006)- “A study on the transition to Electric bikes in China , Effects on Travel Behaviour and user safety perception in medium sized city”
11. James Belias, Pyrou Chung ,James Macdonald (2003) – “A study on Encouraging e bikes use”
12. Mukesh Sharma (2002) – “A study on customer Awareness and perception towards Electric bike”

CONCLUSION

The study is based on the customer satisfaction towards Ampere Electric bike. It concludes the respondents are satisfied with the quality, price and performance of the Ampere E-bike, most of the respondents are motivated by work groups to buy the Ampere E-bike and also customers feels the price of Ampere E-bike is Netural. Most of the respondents feels that ampere e-bikes are easy to drive because it is weightless. So the weight of the bike should not increase in future. The study outcomes also indicates that most of the customers were satisfied and customer loyalty of the Ampere E-bikes is also good.

JOURNAL REFERENCE

1. Elliotfishman, Christopher Cherry (2016) –says about “The e-bikes speaks to one of the quickest developing sections of the showcase”
2. Ashish Aggarwal (2014) –says that from “the research it can concluded that there is strong potential growth in the electric vehicle”.
3. Bhupendra kumar verma (2008)- “ His study states that on the basis of this study , the following suggestions can be made to help in sales of electric bike more effective”
4. Deekshu (2008) – “A study on customer were satisfied with the mileage of the Electric bike benefits and were willing to refer it to their friends”
5. Bamul and simic (2008) –Discussed about the importance of vehicle simulation in designing the hybrid electric vehicle.



A STUDY ON CUSTOMER SATISFACTION TOWARDS ORGANIC PRODUCTS WITH REFERENCE TO TIRUPUR DISTRICT

Dr.S.Suguna

*Assistant professor, Department of commerce with professional accounting,
Dr.N.G.P Arts and Science College, Coimbatore*

Nithya. V

*Student of III B.Com (PA), Department of commerce with Professional Accounting
Dr. N.G.P Arts and Science College, Coimbatore*

ABSTRACT

Now day's peoples prefer organic products than inorganic products due to high conscious about their health. The inorganic products provide harmful effects to health due to high use of chemicals and fertilizers while farming. So the consumers taste, preference and satisfaction has been shifted towards organic products. This study attempts the satisfaction towards organic products with reference towards Tirupur district. The study found that the purchase of organic products increases rapidly by consumers even though the prices are higher, peoples tends to buy organic products for their health safety.

KEYWORDS: *Customer satisfaction , health safety, consumers, organic agriculture, responsibility and price.*

INTRODUCTION

India has lot of potential to produce all varieties of organic products due to its various agro climate regions. In several parts of the country, the inherited tradition of organic farming is an added advantage. Now a day, in India organic products plays a major role in the development of agriculture and health of every individual. The main objective of organic products farming is staying healthy and quality food without any chemical products in it. Organic farm industries are developing with new marketing strategy and enduring for creating healthy environment. Whereas the consumption rate of organic products is sustainably increasing in the past decades. So the consumer behavior has changed towards the organic food item, quality and safety in food, it may also attract consumer interest in organic food products. Thus, organic farming not only saves human beings health but also the environment.

STATEMENT OF THE PROBLEM

As this study concentrates more on organic products. It is little difficult to filter people who purchase and consume organic products from a group of common peoples.

Even though people now a days are started buying and consume organic products. The availability of organic products is less in common places. Even still the chemical and hybrid products are more commonly available than the organic products. The reason is that hybrid products affect the health easily.

SCOPE OF THE STUDY

The scope of the study is to assess the overall customer satisfaction towards the organic products. The main scopes are as follow:

- ✓ The availability of all organic products at reasonable distance from customer's residence.



- ✓ The price and demand of the organic products in current market
- ✓ Trust worthiness towards the purity of organic products.

OBJECTIVES OF THE STUDY

The main objectives of this study are:

- ✓ To know the level of customer satisfaction in organic products.
- ✓ To identify the factors that emerges customer to buy the organic products.
- ✓ To identify the problems faced by the consumers of organic product.

RESEARCH METHODOLOGY**TOOLS FOR ANALYSIS**

The statistical tools used for analysis of the study are:

- ✓ Simple percentage analysis
- ✓ Likert scale analysis

LIMITATIONS OF THE STUDY

- ✓ This study takes into analysis only the customer satisfaction of the customer of organic products.
- ✓ The result is obtained from only by the means of responses from the respondents, so there is a chance for false statement.

REVIEW OF LITERATURE

Ramesh mal. (2005) had studied on, "Organic farming: Its relevancy to the Indian Context". Increasing consciousness about conservation of environment as well as health hazards associated with agrochemicals and consumer? Preference to safe and hazard-free food an major factors that lead to the growing interest in alternate forms of agriculture in the world. Organic agriculture is one among the broad spectrum of production methods that are supportive of the environment.

Anupam Singh, Priyanka verma (2017) This study towards organic product conveys the level of buying behavior towards organic products by consumers. They collected survey from 611 Indian consumers through a structured questionnaire. Their data were analyzed using various techniques like factor analysis, independent t-test etc. Results have confirmed four factors, which influence the consumer attitude towards organic food products.

DATA ANALYSIS AND INTERPRETATION**1. SIMPLE PERCENTAGE ANALYSIS**

Simple percentage analysis is the method to represent raw streams of data as a percentage for better understanding of collected data.

$$\text{Percentage analysis (\%)} = \frac{\text{Number of respondents}}{\text{Total number of respondents}} \times 100$$

TABLE 1
Gender of the respondents

Gender	Respondents	Percentage
Male	38	32
Female	82	68
Total	120	100

(Source: Primary data)

INTERPRETATION

The above table shows the gender of the respondents. Where 68% of the respondents are female and 32% of them are male.

Hence, majority of the respondents (68%) are female.

2. LIKERT SCALE ANALYSIS

Likert scale analysis is mainly used in training course evaluations and market surveys, etc. Likert scale usually has five potential choices but sometimes go up to ten or more. The final average score represents overall level of accomplishment or attitude towards the subject matter. Named after its inventor, the US organizational-behavior psychologist Dr. Rensis likert.

**FORMULA:**

$$\begin{aligned} \text{Likert scale} &= \frac{\sum (fx)}{\text{Total number of respondents}} \\ &= \frac{\sum (f) \times (x)}{120} \\ &= \frac{\sum (fx)}{120} \end{aligned}$$

TABLE 2**Recommendation of organic products to others by the respondents**

Factors	No. of respondents (f)	Likert scale Value (x)	Total score $\sum (fx)$
Strongly recommend	60	4	240
Recommend	54	3	162
May be sometimes	6	2	12
Do not recommend	0	1	0
Total	120		414

(Source: primary data)

$$\begin{aligned} \text{Likert scale} &= \frac{\sum (fx)}{\text{Total number of respondents}} \\ &= \frac{414}{120} \\ &= 3.45 \end{aligned}$$

INTERPRETATION

The above table shows the likert scale value is 3.45 which is greater than the mid value (2.5). So the respondents recommend organic products to others.

FINDINGS, SUGGESTIONS AND CONCLUSION**FINDINGS**

- ❖ It is found that majority of the respondents (68%) are female.
- ❖ It is found that majority of the respondents (35%) are at the age of 25 to 50 years.
- ❖ It is found that majority of the respondents (38%) annual income is 250001-500000
- ❖ It is found that majority of the respondents (63%) are in joint family.
- ❖ It is found that majority of the respondents (52%) are from urban area.
- ❖ It is found that majority of the respondent (45%) buy the organic product.
- ❖ It is found that majority of the respondents (72%) are aware by them self.
- ❖ It is found that majority of the respondents (54%) have thorough knowledge and good understanding on it
- ❖ It is found that majority of the respondents (34%) buy organic products every day.
- ❖ It is found that majority of the respondents (62%) are buying in organic shops.
- ❖ It is found that majority of the respondents (65%) prefer vegetables and fruits.

- ❖ It is found that majority of the respondents (88%) buy for their safe, healthy and nutritious.
- ❖ It is found that majority of the respondents (52%) buy to reduce the health risk
- ❖ It is found that majority of the respondents (40%) high price is the main problem they faced while buying organic products.
- ❖ It is found that majority of the respondents (33%) started to include before 2 to 3 years.
- ❖ It is found that majority of the respondents (52%) says organic products are more expensive
- ❖ It is found that majority of the respondents (72%) definitely buy organic products if the price is cheaper.
- ❖ It is found that majority of the respondents (38%) will continue their purchase till it is affordable to them.
- ❖ It is found that majority of the respondents (67%) opine that organic products are good for using.
- ❖ It is found that the likert scale value is 3.45 which is greater than the mid value (2.5). So the respondents recommend organic products to others.
- ❖ It is found that the likert scale value is 1.28 which is lesser than the mid value (2). So the respondents are dissatisfied with the price of the organic products.
- ❖ It is found that the likert scale value is 2.05 which are greater than the mid value (2). So the



respondents are satisfied with the availability of the organic products.

- ❖ It is found that the likert scale value is 2.8 which is greater than the mid value (2). So the respondents are satisfied with the quality of the organic products.
- ❖ It is found that the likert scale value is 2.23 which are greater than the mid value (2). So the respondents are satisfied with the trustworthiness of the organic products.
- ❖ It is found that the likert scale value is 1.983 which is lesser than the mid value (2). So the respondents are dissatisfied with the time factor of the organic products.
- ❖ It is found that the likert scale value is 2.85 which are greater than the mid value (2). So the respondents are satisfied with the taste of the organic products.

SUGGESTIONS

- ❖ The first and foremost preference must be given to the health of the consumer than taste of the products.
- ❖ Consumers should try to select harmless organic products.
- ❖ The awareness of health complications that might occur when consuming hybrid products must be clearly known to the consumers.
- ❖ The price of the organic products might be brought down for the consumer's satisfaction and preference.
- ❖ Many organic products shop can be opened in order to reduce the less availability of organic products.
- ❖ The awareness must be created to the consumers to buy more organic products than normal products.

CONCLUSION

The study included various aspects of the awareness of the general public over organic products and its consumption. The study evaluated the satisfaction level and reason for the preference of consumers towards organic products. The respondents of this study indicate that they prefer organic products than hybrids for their health safety but price and time factor is major disadvantage they feel while buying. The consumption of organic products increases rapidly. It is now the role of marketers to meet out the demand of the consumers with uninterrupted supply of organic products. So this study suggests valid recommendations to bring a healthy food habit in the near future. Suggested measures must be implemented to develop a healthy nation.

REFERENCE

1. Ramesh organic farming: "it relevance to the Indian context". Vol no. 4, PP 561-568.
2. Anupam Singh, Priyanka Verma Factors influencing Indian consumer's actual buying behavior towards organic food products –journal of cleaner production 167, 473-483, 2017.



A STUDY ON CUSTOMER'S PREFERENCE TOWARDS AMWAY PRODUCTS WITH SPECIAL REFERENCE TO COIMBATORE CITY

Mrs.P. Dhanya

*Associate Professor, Department of Commerce with Professional Accounting,
Dr. N.G.P. Arts and Science College, Coimbatore*

Vishnupriya .B

*Student of III B.Com. (PA), Department of Commerce with Professional Accounting,
Dr.N.G.P Arts and Science College, Coimbatore*

ABSTRACT

Marketing is a powerful mechanism, which satisfy the needs and wants of the consumer f the place and time, they desire. The success of a business depends on the strength policies; in short, marketing guides the decision and action of every business.

Great companies start with great ideas and Amway is no exception. Amway, an abbreviation for “American Way”, was coined in 1959 by founders, Jay Van Andel and Richard De Vos. The business was built on the simple integrity is “Inspiring people and lead better lives”. With the mission to provide best business opportunity, the direct sales business delivers exceptional quality products in the following area.

All the 115 products in four categories sold in India, match Amway’s global quality standards, with a tamper-proof seal and a 100% money back Guarantee. All products are environmentally friendly and not tested on animals. Through its presence in India, the multilevel marketing franchise enhances human resources development through entrepreneurial opportunity and self-employment.

INTRODUCTION

The Amway Indian enterprises franchise’s values have enabled it to guide its actions and help achieve everything without compromise or harm. Amway is one of the most successful American corporation today. The company is presently the world’s largest door-to-door sales corporation, and one of the most extensive service organization. Amway can be seen as one of the most successful merchandise and manufacturing firms today.

(1) CUSTOMER SATISFACTION

The definition of customer satisfaction has been

debated as organizations increasingly attempt to measure it. Customer satisfaction can be experienced in a variety of situations and connected to both goods and services. It is a highly personal assessment that is greatly affected by customer expectation. Satisfaction also is based on the customers experience of the both contacts with the organization and personal outcomes. Some researchers define a satisfied customer within the private sector as “one who receives significant added value” to his/her bottom line.

Customer satisfaction differs depending on the situation and the product or services.



A customer may be satisfied with the product or services, an experience, a purchase decision, a sales person, store, service provider, or an attribute or any of these. To avoid difficulties stemming from kaleidoscope of customer expectation and differences, some experts urge companies to “concentrate on a goal that’s more closely linked to customer equity.

STATEMENT OF THE PROBLEM

Nowadays the customers can purchase any products, but the customer wants to like the quality product. So quality is an important for any product. Now for withstanding a brand, expectation and the level of satisfaction of is customers an essential one. Branded products are most welcome by the customers, because the poor quality products may easily affect the health. So the necessity that has arisen for the study has been to identify the level of customers satisfaction towards Amway products and to know about the causes for shifting their preference from Amway to other brands. Hence, the current study on customer satisfaction towards Amway has been conducted.

SOURCE OF DATA

• PRIMARY DATA

The primary data is the source of collection of information. To analyze the customer satisfaction towards Amway, 120 respondents were selected from within the Coimbatore city. The respondent include students, business people, employees and home maker.

In order to collect the relevant data from the respondents a questionnaires consisting of 23 question was distributed to know the personal opinion of the respondents towards Amway product.

1. SECONDARY DATA

The secondary data is the data is the data that has been already collected by and readily available from other sources. In this project, the data have been collected from the following sources.

1. Journals
2. Articles
3. Websites

LIMITATIONS OF THE STUDY

1. The results of the analysis made in the study are fully depends on the information given by
2. The respondents only.
3. Brand preference of the product may vary from group and also personal bias of the respondents.

REVIEW OF LITERATURE

1. DR.M. Nandhini and B. Devipriya (2014), have written a paper on, “consumer satisfaction towards Amway products in Coimbatore city”

SCOPE OF THE STUDY

1. Factors influencing the customer preference regarding the Amway products.
2. The data has been collected based on the questionnaire schedule.
3. This survey focus on the opinion of the respondents regarding Amway products.

OBJECTIVES OF THE STUDY

1. To find out the factor influencing the customer to but Amway products.
2. To find out the level of satisfaction of the customer.

RESEARCH METHODOLOG

Research methodology is a systematic way to solve research problem. It is science of studying how research is to be carried out. its aim is to give work plan of research. The following includes in it:

4. Books

AREA OF THE STUDY

The study was undertaken in Coimbatore city.

STATISTICAL TOOLS USED

1. Simple percentage analysis
2. Linkert scale analysis
3. Rank analysis.

STATISTICAL TECHQUES

The selection criteria were based upon the data availability, convenience and the level of participation. Hence, the convenience sampling method is adopted.

SAMPLE SIZE

The study was conducted with a sample size of ...respondents in Coimbatore city.

4. The effectiveness of the study may be affected due to the personal bias of the respondents.
5. Due to time constraints, the sample size is limited respondents, with limited respondents the findings may not be applicable to the total population.

the buyer may take decision whether to save or spend the money. When he decide to spend then are many problem as to purchase, because needs are numerous, which leads to ranking the needs in terms of priority. The problem are



consumption problem-where to buy, how to buy, from whom to buy etc. the process whereby individuals decide whether, what, when, how, and from to purchase goods and service can be termed as the customer's or the buyer behavior. All the behavior of human being of human being during the purchase may be termed as "buyer behavior".

2. S. karmugil (2015), conducted a study on "customer satisfaction towards Amway products in Tiruchirappalli town" marketing is the process of finding consumer needs and serving those

PERCENTAGE ANALYSIS

The percentage analysis is mainly used to specify the number of respondents in the sample falling in each category. Further, it is also used as a standard for comparison purpose. A number of respondents

FORMULA PERCENTAGE =

$$\frac{\text{Number of respondents}}{\text{Total number of respondents}} * 100$$

needs profitably. Thus customer is the heart of marketing activities. Marketing people is involved in marketing 10 types of entities. Goods, services, experience, events, persons, places, properties, organization, information, and ideas. Amway products are now fast becoming all class population and the rise in consumerism over the decade is the major force in driving demand. The research is an attempt to find out the customer need and level of satisfaction in the Amway product marketing in Tiruchirappalli town.

distribution shows the number of frequencies in various classes, which helps to get preliminary idea with respect to objectives under study. To interpret the results comprehensively percentage value are computed.

TABLE SHOWING EDUCATIONAL QUALIFICATION

S. NO.	Educational Qualification	No. of Respondents	Percentage
1.	Higher secondary	13	10.83
2.	Under graduate	64	53.33
3.	Post graduate	19	15.83
4.	Professional	19	15.83
	Total	120	95.82

(source: Primary data)

INTERPRETATION

The above table has revealed that 10.83% of the respondent are Higher secondary and 53.33% of the respondents are Under graduate and 15.83% of the

respondents are Post graduate and 15.83% of the respondents are Professional.

Majority (53.33%) of the respondents are under graduate.

LIKERT SCALE ANALYSIS

FORMULA:

$$\text{Likert scale} = \frac{\sum (FX)}{\text{Total number of respondents}}$$

F = Number of Respondents

X = Likert Scale Value

(FX) = Total Scale

**TABLE SHOWING DISTRIBUTION REGARDING THE LEVEL OF SATISFACTION TOWARDS AMWAY PRODUCT ON AVAILABILITY**

S. No	Factors	No. of respondents (f)	Likert scale value (x)	Total (fx)
1.	Excellent	32	5	160
2.	Good	58	4	232
3.	Average	23	3	69
4.	Poor	2	2	4
5.	Very Poor	0	1	0
	Total	120		465

(Source: Primary data)

$$\begin{aligned} \text{Likert Scale} &= (\text{fx}) / \text{Total number of respondents} \\ &= 465/120 \\ &= 3.875 \end{aligned}$$

Likert Scale value (3.875) is higher than a mid-value. So the respondents are satisfied with the Availability of the Amway product

FINDINGS, SUGGESTIONS AND CONCLUSION

FINDING OF SIMPLE PERCENTAGE ANALYSIS

- Majority (50.83%) of the respondents are Male.
- Majority (50.83%) of the respondents are nuclear family.
- Majority (75.83%) of the respondents are Unmarried.
- Majority (53.33%) of the respondents are under graduate.
- Majority (43.33%) of the respondents are 21yrs – 30yrs age group.
- Majority (50%) of the respondents are others.
- Majority (31.66%) of the respondents are one dependents.
- Majority (31.66%) of the respondents are one dependents.
- Majority (27.5%) of the respondents are used beauty care.
- Majority (30.83%) of the respondents says that they buy the Amway product through the Marketing agent.
- Majority (40.83%) of the respondents says that their source of awareness is advertisement.
- Majority (57.5%) of the respondents are using Amway products for less than 6 months.
- Majority (42.5%) of the respondents says that they using high price value of the Amway product .
- Majority (50.83%) of the respondents are using quality of amway product was good.

- Majority (50.83%) of the respondents are using quality of amway product was good.
- Majority (60%) of the respondents are using quality of amway product.

FINDINGS OF LIKERT SCALE ANALYSIS

- Likert Scale value (3.567) is higher than a mid-value. So the respondents are satisfied with the quantity and quality of the Amway product.
- Likert Scale value (3.875) is higher than a mid-value. So the respondents are satisfied with the Availability of the Amway product.

SUGGESTION

- The company should get feedback and follow periodically for the betterment of the customer.
- The company should introduce more avenues to capture the customer.
- The prices should be reduced in order to capture new customer and to retain the old customer.
- Focus should be provided more on young women especially on teenagers. Also steps should be taken to grab the attention of children's preferences towards Amway products.
- To promote the Amway products the company should attract the customers in the way of



providing advertisements and offers for all the products of Amway.

- The company to be successful should have a careful watch over the dynamic customer behavior and come out with a new products and update its existing.

CONCLUSION

Amway products are costly as compared to other branded products available in market. But, if we compare the quality of Amway cannot be beatable. The number of brands available is also increasing, in its place of old products, so, the customers will switch over to other product if they found less satisfaction in using the products. Customer prefers to use new branded products like Amway.

“The study on customer satisfaction towards Amway products” has that the quality is the factor which influenced many respondents to buy the Amway products. At the same time most of the respondents switch over their preference to other brands due to higher price, lack of awareness and offers about Amway products. The Amway company must go for heavy promotional activities (i.e.), must give attractive and frequent advertisement to capture the mind of the customer. The customers are satisfied with the quality of the products. Hence to maintain the brand image of Amway Company, the prices of the products should be reasonable and moreover it must be affordable to all customers.

Thus, the project helped us in knowing the customer satisfaction towards the Amway products.

REFERENCE

1. DR.M. Nandhini and B. Devipriya - consumer satisfaction towards Amway products in Coimbatore.
2. S. karmugil- customer satisfaction towards Amway products in Tiruchirappalli town and marketing activities.
3. Dr. P. Parimaladevi- focuses on what are the benefits received and problems faces by the respondents and their attitude towards the Amway products.
4. M. Rajalakshmi and U. Umadevi- gives help the manufactures to adopt new strategies.



INTEGRATION OF USER INTERFACE WITH FACIAL RECOGNITION SYSTEM

D.Manasa¹

¹ *Department of Computer Science and Engineering, Koneru Lakshmaiah Education Foundation, Vaddeswaram-522502, Guntur, AP, India*

N.Ramya Sri²

² *Department of Computer Science and Engineering, Koneru Lakshmaiah Education Foundation, Vaddeswaram-522502, Guntur, AP, India*

Sk.Naveed³

³ *Department of Computer Science and Engineering, Koneru Lakshmaiah Education Foundation, Vaddeswaram-522502, Guntur, AP, India*

N.Ramya⁴

⁴ *Department of Computer Science and Engineering, Koneru Lakshmaiah Education Foundation, Vaddeswaram-522502, Guntur, AP, India*

Article DOI: <https://doi.org/10.36713/epra5588>

ABSTRACT

Attendance of students in a large classroom is hard to be handled by the traditional system, as it is time-consuming and has a high probability of error during the process of inputting data into the computer. This paper proposed automated attendance marking system using face recognition technique. The system will help to find the positive and negative of the face and Eigen face algorithm for face recognition by using python programming and OpenCV library. The proposed method using PCA to resolve the problems such as lightning of the images, and the direction of the student faces. The attendance of the student was updated to the Excel sheet after student's face has been recognized.

KEYWORDS: *PCA, Facial Recognition, ERP, Classroom, Attendance*

1. INTRODUCTION

The enhancement of science and technology leads to make the life more comfortable than older days. The emerging technologies like neutrosophic shortest path [1,2,3,4,5], transportation problem [6,7,8], uncertainty problem [9,10,11,12,13,14], fuzzy shortest path [15,16,17,18,19], PowerShell [20], wireless sensor network [21,22,23,24,25,26,27,28], computer language

[29,30], neural network [31], routing [32] making the products more intelligent and self-healing based. The smart city applications like smart water, smart grid, smart parking, smart resource management, etc. are based on IoT and IoE [33,34, 35, 36] technologies. We have the development available to us to enable the organization of our consistently lives and the sharing of significant information with our associates, families and others. Why development is huge in our



consistently life. It is a basic contraption that we can't avoid, it has a huge impact in the vast majority of our lives. Technology fundamentally handles the instruments, advancements and strategies used to help us with dealing with issues and simply improve our everyday schedules and easier to encounter to a great extent [37,38]. Advancement is inevitable in our normal everyday presences [39]. This is in light of the fact that presence without advancement is senseless in the present incredible world. Development, which joins instruments to propel unforeseen development, use and information exchange, has as its basic objective of making tasks easier and the handling of various issues of mankind. Right when development advances and makes our continues with extensively more worthwhile, we should pressure that it is so useful to our lives.

Face recognition technology is very helpful to take attendance in an easy manner more over it doesn't require more effort from the user end while compared with other biometric options. Biometric face recognition is basically used in three main domains: time attendance systems and employee management; visitor management systems; and last but not the least authorization systems and access control systems. So in this project we are going to design a attendance management system by face recognition technique. In this we are going to take attendance of the students. By using different methods or languages we can implement this attendance system for example for designing login page we will use HTML,CSS and for storing the data we will use Java Script, Database. And for capturing the photo of the student we will use openCV Python. So finally by combining all the software's we can implement this project.



Fig.1 User interface for login



Fig 2: Capturing the image.

2. LITERATURE SURVEY

S.no	Author Used for Implementation	Methods used for implementation	Specifications of the method	Limitations/Research
1.	Mathana Gopala Krishnan, Balaji, Shyam Babu In 2006	Implementation of Automated Attendance System using Face Recognition.	In this the author designed the project in such a way that once the image is captured we cannot change once again	Final output is that it will capture the images and allot the attendance
2.	Nirmalya Kar, Dr. Mrinal Kanti Deb Barma, Ashim Saha In 2012	Study of Implementing Automated Attendance System Using Face Recognition Technique by OpenCV python	The system will record the attendance of the students in class room environment automatically and it will provide the facilities to the faculty to access the information of the students easily by maintaining a log for clock-in and clock-out time.	It will store the data in the data base after capturing the images it will also display the name of the person

Table 1. Literature Survey

3. PROPOSED WORK

In this project m work is to design the html pages for the login page by using CSS, Html.In this particular module we must prepare the register page also, so the new user can register first and then the person can login to give the attendance. By using

different type of commands .And in this we also use JavaScript and database to store the information of the person. While designing the login page it must be user friendly and also it must be easily understood to a person. In this we must design the two different pages for the student and faculty.

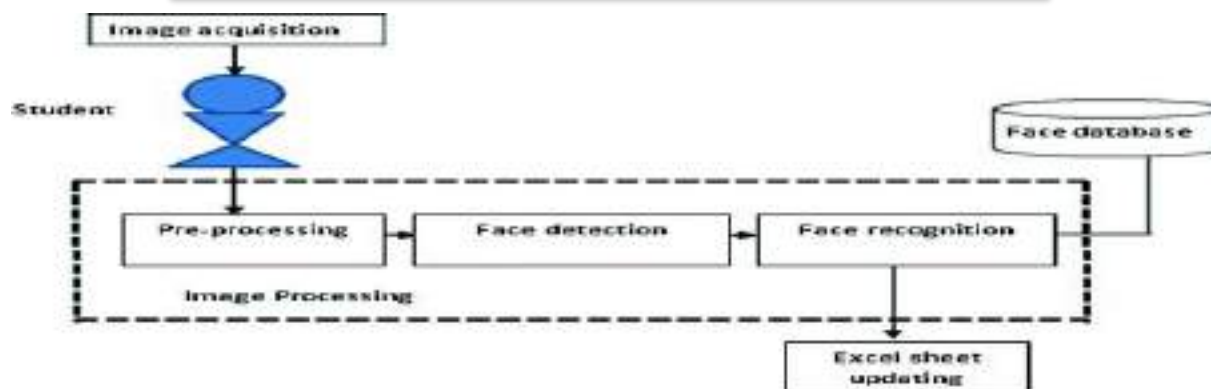

Fig. 3 working diagram of proposed model

4. RESULT

The total result of this project is that to mark the attendance of the student in such a way that there will be no chances for proxy attendance. And by this project there will be no stress for the faculty about the manual attendance.

Using PCA algorithm the following steps would be followed in for face recognition:

Step 1: The person must login through the portal.

Step 2: He must select the subject and hour for marking the attendance.

Step 3: Begin:

- Find the face information of matched face image in from the database.
- Update the log table with corresponding face image and system time that makes completion of attendance for an individual students.

Step 4: End

REFERENCES

1. Broumi, S., Dey, A., Talea, M. et al. Shortest path problem using Bellman algorithm under neutrosophic environment. *Complex & Intelligent Systems*, 5 (2019), 409-416.
2. Kumar, R., Dey, A., Broumi, S., and Smarandache, F. A study of neutrosophic shortest path problem. In *Neutrosophic Graph Theory and Algorithms*. IGI Global, 2020.
3. Kumar, R., Edalatpanah, S. A., Jha, S., Broumi, S., Singh, R., and Dey, A. A multi objective programming approach to solve integer valued neutrosophic shortest path problems. *Neutrosophic Sets and Systems*, 24 (2019), 139-151.
4. Kumar, R., Edalatpanah, S. A., Jha, S., and Singh, R. A novel approach to solve gaussian valued neutrosophic shortest path problems. *International Journal of Engineering and Advanced Technology*, 8 (2019), 347-353.
5. Kumar, R., Edalatpanah, S. A., Jha, S., Broumi, S., and Dey, A. Neutrosophic shortest path problem. *Neutrosophic Sets and Systems*, 23 (2018), 5-15.
6. Pratihari, J., Kumar, R., Dey, A., and Broumi, S. Transportation problem in neutrosophic environment. In *Neutrosophic Graph Theory and Algorithms*. IGI Global, 2020.
7. Kumar, R., Edalatpanah, S. A., Jha, S., and Singh, R. A Pythagorean fuzzy approach to the transportation problem. *Complex & Intelligent Systems*, 5 (2019), 255-263.
8. Pratihari, J., Kumar, R., Edalatpanah, S. A., and Dey, A. Modified Vogel's approximation method for transportation problem under uncertain environment. *Complex & Intelligent Systems* (2020), 1-12.
9. Gayen, S., Jha, S., Singh, M., and Kumar, R. On a generalized notion of anti-fuzzy subgroup and some characterizations. *International Journal of Engineering and Advanced Technology*, 8 (2019), 385-390.
10. Gayen, S., Smarandache, F., Jha, S., and Kumar, R. Interval-valued neutrosophic subgroup based on interval-valued triple t-norm. In *Neutrosophic Sets in Decision Analysis and Operations Research*. IGI Global, 2020.
11. Gayen, S., Smarandache, F., Jha, S., Singh, M. K., Broumi, S., and Kumar, R. Introduction to plithogenic subgroup. In *Neutrosophic graph Theory and Algorithms*. IGI Global, 2020.
12. Gayen, S., Smarandache, F., Jha, S., Singh, M. K., Broumi, S., and Kumar, R. Soft Subring Theory Under Interval-valued Neutrosophic Environment. *Neutrosophic Sets and Systems*, 36 (2020), 16.
13. Gayen, S., Smarandache, F., Jha, S., and Kumar, R. Introduction to interval-valued neutrosophic subring. *Neutrosophic Sets and Systems*, 36 (2020), 17.
14. Gayen, S., Smarandache, F., Jha, S., Singh, M. K., Broumi, S., and Kumar, R. Introduction to plithogenic hypersoft subgroup. *Neutrosophic Sets and Systems*, 33 (2020), 208-233.
15. Kumar, R., Edalatpanah, S. A., and Mohapatra, H. Note on ``Optimal path selection approach for



- fuzzy reliable shortest path problem`. *Journal of Intelligent & Fuzzy Systems* (2020), 1-4.
16. Kumar, R., Jha, S., and Singh, R. A different approach for solving the shortest path problem under mixed fuzzy environment. *International Journal of Fuzzy System Applications*, 9 (2020), 132-161.
 17. Kumar, R., Jha, S., and Singh, R. Shortest path problem in network with type-2 triangular fuzzy arc length. *Journal of Applied Research on Industrial Engineering*, 4 (2017), 1-7.
 18. Kumar, Ranjan, Edalatpanah, S. A., Jha, Sripathi, Gayen, Sudipta, and Singh, Ramayan. Shortest path problems using fuzzy weighted arc length. *International Journal of Innovative Technology and Exploring Engineering*, 8 (2019), 724-731.
 19. Kumar, R., Edalatpanah, S. A., Jha, S., Gayen, S., and Singh, R. Shortest path problems using fuzzy weighted arc length. *International Journal of Innovative Technology and Exploring Engineering*, 8 (2019), 724-731.
 20. Mohapatra, H., Panda, S., Rath, A. K., Edalatpanah, S. A., and Kumar, R. A tutorial on powershell pipeline and its loopholes. *International Journal of Emerging Trends in Engineering Research*, 8 (2020), 975-982.
 21. Mohapatra, H., Rath, S., Panda, S., and Kumar, R. Handling of man-in-the-middle attack in wsn through intrusion detection system. *International Journal of Emerging Trends in Engineering Research*, 8 (2020), 1503-1510.
 22. Mohapatra, H., Debnath, S., and Rath, A. K. Energy management in wireless sensor network through eb-leach. *International Journal of Research and Analytical Reviews*, 56 (2018), 56-61.
 23. Mohapatra, H., Rath, A. K., Landge, P. B., Bhise, D., Panda, S., and Gayen, S. A comparative analysis of clustering protocols of wireless sensor network. *International Journal of Mechanical and Production Engineering Research and Development*, 10 (2020), 8371-8386.
 24. Mohapatra, H. and Rath, A. K. A survey on fault tolerance based clustering evolution in wsn. *IET Networks* (2020).
 25. Mohapatra, H., Debnath, S., Rath, A. K., Landge, P. B., Gayen, S., and Kumar, R. An efficient energy saving scheme through sorting technique for wireless sensor network. *International Journal of Emerging Trends in Engineering Research*, 8 (2020), 4278-4286.
 26. Mohapatra, H. and Rath, A. K. Fault tolerance in wsn through uniform load distribution function. *International Journal of Sensors, Wireless Communications and Control*, 10 (2020).
 27. Mohapatra, H. and Rath, A. K. Fault tolerance through energy balanced cluster formation (ebcf) in wsn. In *Smart Innovations in Communication and Computational Sciences* (2018), springer, 313-321.
 28. Mohapatra, Hitesh and Rath, Amiya Kumar. Fault tolerance in WSN through PE-LEACH protocol. *IET Wireless Sensor Systems*, 9, 6 (Dec. 2019), 358-365(7).
 29. Mohapatra, H. C *Programming: Practice*. Amazon, 2018.
 30. Mohapatra, H. and Rath, A. K. *Fundamentals of Software Engineering*. BPB, 2020.
 31. Mohapatra, H. *HCR by Using Neural Network*. 2009.
 32. Panda, M., Pradhan, P., Mohapatra, H., and Barpanda, N. K. Fault tolerant routing in heterogeneous environment. *International Journal of Scientific & Technology Research*, 8 (2019), 1009-1013.
 33. Mohapatra, H. Offline drone instrumentalized ambulance for emergency situations. *International Journal of Robotics and Automation*, 9 (2020), 251-255.
 34. Mohapatra, H. and Rath, A. K. Detection and avoidance of water loss through municipality taps in india by using smart tap and ict. *IET Wireless Sensor Systems* (2019), <https://doi.org/10.1049/iet-wss.2019.00000>.
 35. Panda, H., Mohapatra, H., and Rath, A. K. Wsn-based water channelization: an approach of smart water. In *Smart Cities: Opportunities and Challenges*. Springer, Singapore, 2020.
 36. Rout, S. S., Mohapatra, H., Nayak, R. K., Tripathy, R., Bhise, D., Patil, S. P., and Rath, A. K. Smart water solution for monitoring of water usage based on weather condition. *International Journal of Engineering and Technical Research*, 8 (2020), 5335-5343.



FACE RECOGNITION FOR THE AUTOMATIC ATTENDANCE MANAGEMENT SYSTEM

N.Ramya Sri¹

¹ *Department of Computer Science and Engineering
Koneru Lakshmaiah Education Foundation, Vaddeswaram-522502, Guntur, AP, India*

D.Manasa²

² *Department of Computer Science and Engineering
Koneru Lakshmaiah Education Foundation, Vaddeswaram-522502, Guntur, AP, India*

N.Ramya³

³ *Department of Computer Science and Engineering
Koneru Lakshmaiah Education Foundation, Vaddeswaram-522502, Guntur, AP, India*

Sk.Naveed⁴

⁴ *Department of Computer Science and Engineering
Koneru Lakshmaiah Education Foundation, Vaddeswaram-522502, Guntur, AP, India*

Article DOI: <https://doi.org/10.36713/epra5583>

ABSTRACT

Face Recognition is a currently developing technology with multiple real- life applications. The goal of this Thesis is to develop a complete Face Recognition system. The system uses Convolutional Neural Networks in order to extract relevant facial features. These features allow to compare faces between them in an efficient way. The system can be trained to recognize a set of people, and to learn in an on-line way, by integrating the new people. Face recognition system is one of the biometric information process its applicability is easier and working range is larger than others .The face recognition is live acquired images without any application field in mind .process utilized in the system are White Balance correction ,skin like region segmentation .facial feature extraction and face image extraction on a face Candidate .The face one of the easiest ways to distinguish the individual identify each other .Face recognition is a personal identification system that uses personal characteristics of a person to identify the person's identify.

KEYWORDS:-Face Recognition, Facial Attendance, Automatic Attendance, Face Detection.

1.INTRODUCTION

Face recognition is as old as computer vision, both because of the practical importance of the topic and theoretical interest from cognitive scientists [1]. Despite the fact that other methods of identification (such as fingerprints, or iris scans) can be more accurate, face recognition has always remains a major focus of research because of its noninvasive nature and because it is people's primary method of person identification [2]. Face

recognition technology is gradually evolving to a universal biometric solution since it requires virtually zero effort from the user end while compared with other biometric options [3]. Biometric face recognition is basically used in three main domains: time attendance systems and employee management; visitor management systems; and last but not the least authorization systems and access control systems [4].

The enhancement of science and technology leads to make the life more comfortable than older days. The emerging



technologies like neutrosophic shortest path [1,2,3,4,5], transportation problem [6,7,8], uncertainty problem [9,10,11,12,13,14], fuzzy shortest path [15,16,17,18,19], PowerShell [20], wireless sensor network [21,22,23,24,25,26,27,28], computer language [29,30], neural network [31], routing [32] making the products more intelligent and self-healing based. The smart city applications like smart water, smart grid, smart parking, smart resource management, etc. are based on IoT and IoE [33,34,35,36, 37] technologies. We have the development available to us to enable the organization of our consistently lives and the sharing of significant information with our associates, families and others. Why development is huge in our consistently life. It is a basic contraption that we can't avoid, it has a huge impact in the vast majority of our lives Technology fundamentally handles the instruments, advancements and strategies used to help us with dealing with issues and simply improve our everyday schedules and easier to encounter to a great extent [38,39]. Advancement is inevitable in our normal everyday presences [40]. This is in light of the fact that presence without advancement is senseless in the present incredible world. Development, which joins instruments to propel unforeseen development, use and information exchange, has as its basic objective of making tasks easier and the handling of various issues of mankind. Right when development advances and makes our continues with extensively more worthwhile, we should pressure that it is so useful to our lives.

2.1 THE FACE RECOGNITION

That being said, this problem is also a really difficult one, and it has not been until recent years that quality results are being obtained [5]. In fact, this problem is usually split into different sub-problems to make it easier to work with, mainly face detection in an image, followed by the face recognition itself [6]. There are also other tasks that can be performed in-between, such as frontolyzing faces, or extracting additional features from them [7]. Through the years, many algorithms and techniques have been used, such as eigenfaces or Active Shape models. However, the one that is currently mostly used, and providing the best results, These are currently obtaining high quality results, so, after reviewing the current state of art, we decided to focus this project on them [8].

2.2 GOAL AND IMPLEMENTATION

Our goal was to create a complete Face Recognition for Attendance management system, capable of working with any kind of images, and to constantly improve itself [9]. This improvement had to be autonomous, and to allow it to better recognize people in it, and to include new ones. On top of that, the time requirements were also an issue, as this recognition must be done as close to real-time as possible. The task of recognizing faces, especially outside of controlled conditions, is an extremely difficult problem [10]. In fact, there have been many approaches throughout the history that have not succeeded. Apart from the variance between pictures of the same face, such as expression, light conditions or facial hair, it is difficult to determine what makes a face recognizable [11]. The main reasons are the good results obtained being really close to the state of art, and the quality of the description. It consists in a

3-step process [12]. First, the face in the image is located and frontolyzed, so that it is looking at the camera. Then, the frontolyzed face is sent through , and a set of relevant features are extracted [13]. Finally, these features are used as attributes to compare pairs of images to determine whether they belong or not to the same person .And Marks the attendance automatically in the excel sheets [14].

3. LITERATURE REVIEW

3.1 A Counterpart Approach to Attendance

System using OpenCV Technique :In this paper, the idea of technology namely Student Attendance has been implemented .This system automatically detects the student performance and maintains the student's records like attendance and their feedback on the subjects .Therefore the attendance of the student can be made available by recognizing the face. On recognizing, the attendance details and details about the marks of the student is obtained as feedback [2]. Other paper proposed by introduced a real-time computer vision algorithm in automatic attendance management system. The system installed the camera with non-intrusive, which can snap images in the classroom and compared the extracted face from the image of the camera capturing with faces inside the system. Also HAAR CLASSIFIERS used to train the images from the camera capturing. The face snap by the camera capturing will convert to grayscale and do subtraction on the images; then the image is transferred to store on the server and processing later [3].

4. MOTIVATION OR MATERIAL AND METHODS

4.1 PROPOSED PROPOSAL

Every institute has its own method to keep record of attendance of students. Some are taking attendance manually using the traditional pen and paper or file based approach but marking attendance is a lengthy process and takes lot of time and effort, especially if it is a lecture with huge number of students. Also dealing with the records of a large number of students often leads to human error. So we are implementing a system to automatically record the students' attendance during lecture hours in a hall or room using facial recognition technology. This project deals with one of the possible solutions.

4.2 ARCHITECTURE

The main working principle of the project is that, the video captured data is converted into image to detect and recognize it. Further the recognized image of the student is provided with attendance; else the system marks the database as absent.

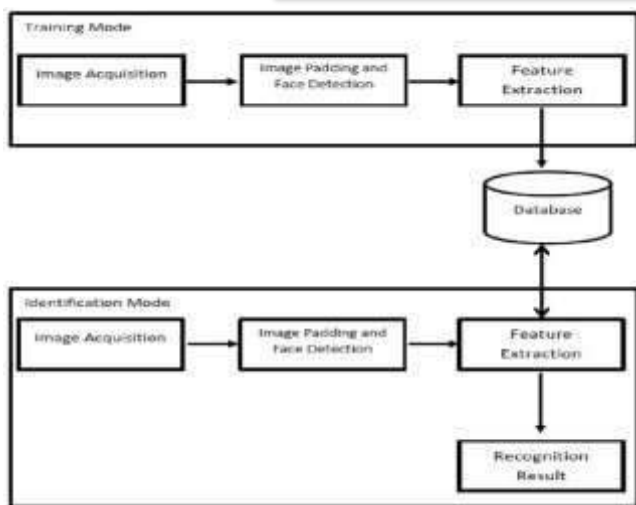

Fig 1. Architecture of proposed model

4.3 METHODOLOGY

Our purpose is to make a facial recognition system which needs as less training data as possible. The main reason behind this constraint is the fact that it is more useful for a supervisor to have train the model with one or few pictures for each student rather than having to make a large Dataset with many images for the same person. We will be comparing two main face classification models, PCA dimensionality reduction, and pretrained.

To perform face recognition, the following steps will be followed:

- Detecting all faces included in the image (face detection).
- Cropping the faces and extracting their features.
- Applying a suitable facial recognition algorithm to compare faces with the database of students and lecturers.
- Providing a file recording the identified attendants.

This chapter contains block diagram of face recognition based attendance monitoring system. The elements of block diagram of face recognition based attendance monitoring system using OpenCV are also explained. The process of person identification by using face recognition can be split into three main phases. These are registration and normalization, feature extraction and classification are explained [4]. Our purpose is to make a facial recognition system which needs as less training data as possible. The main reason behind this constraint is the fact that it is more useful for a supervisor to have train the model with one or few pictures for each student rather than having to make a large Dataset with many images for the same person. To perform face recognition the following steps will be followed:

- Detecting all faces included in the image (face detection).
- Cropping the faces and extracting their features.
- Applying a suitable facial recognition algorithm to compare faces with the database of students and lecturers.

- Providing a file recording the identified attendants.

How OpenCV's face recognition works



Fig.2 OpenCV Simulation

5. RESULTS AND DISCUSSION

5.1 FACE DETECTION

The result of the face Recognition System depends upon the characteristics, position, feature, Extraction and identification of the face image to be analyzed facial recognition process normally has four phases are steps. First Face detection and another one normalization and also feature extraction. Three-dimensional face recognition technique user's 3D sensors to capture information about the shape of a face. A facial recognition system uses biometrics to map facial features from photography or video. In digital camera terminology face detection also called face priority. And a function of a camera that detects human faces.

5.2 FACIAL RECOGNITION

Facial recognition is a Biometric software application capable of uniquely identifying or verifying a person by comparing and analyzing patterns based on the persons facial contours. And it is used for security purposes .In face detection I identify Eyes ,Nose ,Mouth .Open CV is the most popular library for Computer Vision .It used for faces Within a Picture and the Faces are complicated .Facial recognition is basically the task of recognition a person Based on its facial image .It has project of Finding Faces. Face recognition Work By identifying facial features by extracting features ,or landmarks From the image of face .For example ,to extract facial features shape and size of the Eyes ,the Size of nose ,and Relative position with Eyes.

6. SUMMARY AND CONCLUSION

The enhancement of science and technology leads to make the life more comfortable than older days. The emerging technologies like wireless sensor network [7,8], IoT [9,10], embedded system [11,12] neutrosophic algorithms [13], fuzzy and neural network based algorithms [14], data science, data mining [15, 16] making the products more intelligent and self-healing based. The smart city applications like smart water, smart grid, smart parking, smart resource management, etc. are based on IoT and IoE technologies [17, 18]. We have the development available to us to enable the organization of our consistently lives and the sharing of significant information



with our associates, families and others [19, 20]. Why development is huge in our consistently life. It is a basic contraption that we can't avoid, it has a huge impact in the vast majority of our lives Technology fundamentally handles the instruments, advancements and strategies used to help us with dealing with issues and simply improve our everyday schedules and easier to encounter to a great extent [21, 22]. Advancement is inevitable in our normal everyday presences [23]. This is in light of the fact that presence without advancement is senseless in the present incredible world [24]. Development, which joins instruments to propel unforeseen development, use and information exchange, has as its basic objective of making tasks easier and the handling of various issues of mankind. Right when development advances and makes our continues with extensively more worthwhile, we should pressure that it is so useful to our lives.

We have developed a fully working Face Recognition system, with the capacity of on-line learning without human intervention. It can work with any kind of images, and is reasonably robust to changes in face expression or orientation, light conditions and other factors. We have based our face verification step on the deep Face [Taigman et al., 2014] system, which we have used to provide facial features to our FR system. The obtained system has been extensively tested, and different parameters combinations have been tried. We have used the Large Face in the Wild Huang et al., 2007 dataset to assess the performance of our face verification step. Apart from that, we have gathered a 600,000 face images dataset to use both in training and testing. The facial recognition part has been tested using two different sized datasets, and we have obtained steady results around the 90% of accuracy, reaching a maximum of 95%. These results are better than the ones we expected, and they allow for some real-life use cases. However, there is still room for improvement, as explained in following Section.

Two real applications of the FR technology have also been presented. The first one is an online web tool that allows for easily training and testing a whole FR system by simply providing sets of images. Even though it is still an alpha version, with limited functionality, it is fully operational and has proven to be useful for demonstration purposes. The other application consists in recognizing people in videos. After processing the video, it draws the bounding box of each person in it, following them around the screen, and writes the name of identified people. It is already working for videos with one person in it, and it is currently being upgraded to allow for multiple people recognition.

6.2 FUTURE WORK

Throughout the document we have already pointed out some aspects that should be improved in the future. The main part that needs to be worked on is to enhance the feature extraction part. The currently used is still underperforming compared with the current state of art. As this part is the basis of the whole FR system, any final performance. In order to do so, we plan on gathering more data for training; more thoroughly test the parameters and various configurations, and further experiment with data augmentation. I have developed a fully working Face Recognition system, with the capacity of on-line learning without human intervention. It can work with any kind

of images, and is reasonably robust to changes in face expression or orientation, light conditions and other factors.

REFERENCES

1. Broumi, S., Dey, A., Talea, M. et al. Shortest path problem using Bellman algorithm under neutrosophic environment. *Complex & Intelligent Systems*, 5 (2019), 409-416.
2. Kumar, R., Dey, A., Broumi, S., and Smarandache, F. A study of neutrosophic shortest path problem. In *Neutrosophic Graph Theory and Algorithms*. IGI Global, 2020.
3. Kumar, R., Edalatpanah, S. A., Jha, S., Broumi, S., Singh, R., and Dey, A. A multi objective programming approach to solve integer valued neutrosophic shortest path problems. *Neutrosophic Sets and Systems*, 24 (2019), 139-151.
4. Kumar, R., Edalatpanah, S. A., Jha, S., and Singh, R. A novel approach to solve gaussian valued neutrosophic shortest path problems. *International Journal of Engineering and Advanced Technology*, 8 (2019), 347-353.
5. Kumar, R., Edalatpanah, S. A., Jha, S., Broumi, S., and Dey, A. Neutrosophic shortest path problem. *Neutrosophic Sets and Systems*, 23 (2018), 5-15.
6. Pratihari, J., Kumar, R., Dey, A., and Broumi, S. Transportation problem in neutrosophic environment. In *Neutrosophic Graph Theory and Algorithms*. IGI Global, 2020.
7. Kumar, R., Edalatpanah, S. A., Jha, S., and Singh, R. A Pythagorean fuzzy approach to the transportation problem. *Complex & Intelligent Systems*, 5 (2019), 255-263.
8. Pratihari, J., Kumar, R., Edalatpanah, S. A., and Dey, A. Modified Vogel's approximation method for transportation problem under uncertain environment. *Complex & Intelligent Systems* (2020), 1-12.
9. Gayen, S., Jha, S., Singh, M., and Kumar, R. On a generalized notion of anti-fuzzy subgroup and some characterizations. *International Journal of Engineering and Advanced Technology*, 8 (2019), 385-390.
10. Gayen, S., Smarandache, F., Jha, S., and Kumar, R. Interval-valued neutrosophic subgroup based on interval-valued triple t -norm. In *Neutrosophic Sets in Decision Analysis and Operations Research*. IGI Global, 2020.
11. Gayen, S., Smarandache, F., Jha, S., Singh, M. K., Broumi, S., and Kumar, R. Introduction to plithogenic subgroup. In *Neutrosophic graph Theory and Algorithms*. IGI Global, 2020.
12. Gayen, S., Smarandache, F., Jha, S., Singh, M. K., Broumi, S., and Kumar, R. Soft Subring Theory Under Interval-valued Neutrosophic Environment. *Neutrosophic Sets and Systems*, 36 (2020), 16.
13. Gayen, S., Smarandache, F., Jha, S., and Kumar, R. Introduction to interval-valued neutrosophic subring. *Neutrosophic Sets and Systems*, 36 (2020), 17.
14. Gayen, S., Smarandache, F., Jha, S., Singh, M. K., Broumi, S., and Kumar, R. Introduction to plithogenic hypersoft subgroup. *Neutrosophic Sets and Systems*, 33 (2020), 208-233.
15. Kumar, R., Edalatpanah, S. A., and Mohapatra, H. Note on "Optimal path selection approach for fuzzy reliable shortest path problem". *Journal of Intelligent & Fuzzy Systems* (2020), 1-4.
16. Kumar, R., Jha, S., and Singh, R. A different approach for solving the shortest path problem under mixed fuzzy environment. *International Journal of Fuzzy System*



- Applications, 9 (2020), 132-161.
17. Kumar, R., Jha, S., and Singh, R. Shortest path problem in network with type-2 triangular fuzzy arc length. *Journal of Applied Research on Industrial Engineering*, 4 (2017), 1-7.
 18. Kumar, Ranjan, Edalatpanah, S. A., Jha, Sripathi, Gayen, Sudipta, and Singh, Ramayan. Shortest path problems using fuzzy weighted arc length. *International Journal of Innovative Technology and Exploring Engineering*, 8 (2019), 724-731.
 19. Kumar, R., Edalatpanah, S. A., Jha, S., Gayen, S., and Singh, R. Shortest path problems using fuzzy weighted arc length. *International Journal of Innovative Technology and Exploring Engineering*, 8 (2019), 724-731.
 20. Mohapatra, H., Panda, S., Rath, A. K., Edalatpanah, S. A., and Kumar, R. A tutorial on powershell pipeline and its loopholes. *International Journal of Emerging Trends in Engineering Research*, 8 (2020), 975-982.
 21. Mohapatra, H., Rath, S., Panda, S., and Kumar, R. Handling of man-in-the-middle attack in wsn through intrusion detection system. *International Journal of Emerging Trends in Engineering Research*, 8 (2020), 1503-1510.
 22. Mohapatra, H., Debnath, S., and Rath, A. K. Energy management in wireless sensor network through eb-leach. *International Journal of Research and Analytical Reviews*, 56 (2018), 56-61.
 23. Mohapatra, H., Rath, A. K., Landge, P. B., Bhise, D., Panda, S., and Gayen, S. A comparative analysis of clustering protocols of wireless sensor network. *International Journal of Mechanical and Production Engineering Research and Development*, 10 (2020), 8371-8386.
 24. Mohapatra, H. and Rath, A. K. A survey on fault tolerance based clustering evolution in wsn. *IET Networks* (2020).
 25. Mohapatra, H., Debnath, S., Rath, A. K., Landge, P. B., Gayen, S., and Kumar, R. An efficient energy saving scheme through sorting technique for wireless sensor network. *International Journal of Emerging Trends in Engineering Research*, 8 (2020), 4278-4286.
 26. Mohapatra, H. and Rath, A. K. Fault tolerance in wsn through uniform load distribution function. *International Journal of Sensors, Wireless Communications and Control*, 10 (2020).
 27. Mohapatra, H. and Rath, A. K. Fault tolerance through energy balanced cluster formation (ebcf) in wsn. In *Smart Innovations in Communication and Computational Sciences* (2018), springer, 313-321.
 28. Mohapatra, Hitesh and Rath, Amiya Kumar. Fault tolerance in WSN through PE-LEACH protocol. *IET Wireless Sensor Systems*, 9, 6 (Dec. 2019), 358-365(7).
 29. Mohapatra, H. *C Programming: Practice*. Amazon, 2018.
 30. Mohapatra, H. and Rath, A. K. *Fundamentals of Software Engineering*. BPB, 2020.
 31. Mohapatra, H. *HCR by Using Neural Network*. 2009.
 32. Panda, M., Pradhan, P., Mohapatra, H., and Barpanda, N. K. Fault tolerant routing in heterogeneous environment. *International Journal of Scientific & Technology Research*, 8 (2019), 1009-1013.
 33. Mohapatra, H. Offline drone instrumentalized ambulance for emergency situations. *International Journal of Robotics and Automation*, 9 (2020), 251-255.
 34. Mohapatra, H. and Rath, A. K. Detection and avoidance of water loss through municipality taps in india by using smart tap and ict. *IET Wireless Sensor Systems* (2019), <https://doi.org/10.1049/iet-wss.2019.0000>.
 35. Panda, H., Mohapatra, H., and Rath, A. K. Wsn-based water channelization: an approach of smart water. In *Smart Cities: Opportunities and Challenges*. Springer, Singapore, 2020.
 36. Rout, S. S., Mohapatra, H., Nayak, R. K., Tripathy, R., Bhise, D., Patil, S. P., and Rath, A. K. Smart water solution for monitoring of water usage based on weather condition. *International Journal of Engineering and Technical Research*, 8 (2020), 5335-5343.
 37. Mohapatra, H. and Rath, A. K. IoT-based smart water. *IOT Technologies in Smart-Cities: From Sensors to Big Data, Security and Trust* (2020), 63.
 38. Mohapatra, H. and Rath, A. K. Nub less sensor based smart water tap for preventing water loss at public stand posts. In *Microwave Theories and Techniques in Wireless Communications (MTTW'20)*, IEEE (2020), 145-150.
 39. Nirgude, V. N., Nirgude, V. N., Mahapatra, H., and Shivarkar, S. A. Face recognition system using principal component analysis & linear discriminant analysis method simultaneously with 3d morphable model and neural network BPNN method. *Global Journal of Advanced Engineering Technologies and Sciences*, 4 (2017), 1-6.



FORMULATION DEVELOPMENT OF BUCCAL FILM OF CARVEDILOL PHOSPHATE

Adiba Mulla^{1*}

¹Navsahyadri Institute of pharmacy ,Naigaon-Nasarapur,Pune -412213.

Rasika Mulik²

²Navsahyadri Institute of pharmacy ,Naigaon-Nasarapur,Pune -412213.

* Corresponding author: Adiba Mulla

ABSTRACT

Carvedilol phosphate, β -adrenergic antagonist has hepatic first pass effect and low oral bioavailability (25-30%). Hence need arises to develop buccal film of carvedilol phosphate to provide rapid onset of action. Carvedilol phosphate was taste masked by using β -cyclodextrin. Buccal film of taste masked formulation were prepared by solvent casting method based on 3^2 factorial design using polyvinyl pyrrolidone K30 and polyvinyl alcohol. All the films were evaluated for their thickness, weight variations, folding endurance, swelling index, surface pH, disintegration time, drug content, in-vitro drug release, ex-vivo permeation studies and stability study. The FTIR and DSC studies revealed no interaction between drug and polymer. The films were thin, transparent, smooth, flexible and uniform in drug content, weight and thickness. Results showed that F2 containing 4% PVPK30 and 2% polyvinyl alcohol was optimized formulation which showed 98.98% drug release within 21 min. Ex vivo diffusion studies carried out using Franz diffusion cell with goat buccal mucosa and cellophane membrane showed 91.53% and 94.84% of drug release, respectively. From the all evaluation parameter it was concluded that buccal film of carvedilol phosphate is good choice of dosage form for faster action.

KEYWORDS: Carvedilol phosphate, taste masking, buccal film.

INTRODUCTION

Buccal drug delivery is a highly effective way to improve bioavailability. This is because the buccal mucosa has rich blood supply which facilitates direct entry of drug molecules into the systemic circulation. Buccal drug delivery is well accepted by patients the buccal cavity is easily accessible for self-medication. In addition, buccal dosage form swallow drug absorption to be rapidly terminated in case of an adverse reaction. Formulation of buccal dosage forms include adhesive tablet, gels, patch & film of which film are preferable in terms of flexibility and comforts. Buccal films were prepared by using polymer. Carvedilol phosphate is β -adrenergic antagonist use in the treatment of hypertension. Its oral bioavailability is 25-35%. Carvedilol was selected because of low molecular weight (406.48) and low oral dose is low (6.25-25mg). for buccal drug delivery system.

Objective of work to mask bitter taste of drug using known concentration of β -cyclodextrin and to prepare evaluate the carvedilol phosphate buccal film by solvent casting method.

MATERIAL AND METHODS

Materials:- Carvedilol was obtained as a gift sample from Mylan Pvt Ltd, Nashik, India. Polyvinyl pyrrolidone K 30 and polyvinyl alcohol were obtained from the Research lab fine chem, India. All other materials used were of analytical grade.

Methods

Taste masking of drug:-Taste masking was carried out by preparation of complex of carvedilol with beta cyclodextrin. A mixture of carvedilol and β -cyclodextrin in 1:2 ratio was grounded in mortar by adding hydroalcoholic solution (ethanol:water =15:85) and kneaded thoroughly with a pestle to obtain a paste which was dried under vacuum at



room temperature passed through sieve no.60 and stored in a desiccators (Mohd Azharuddin et al 2012).

Preparation of buccal film of carvedilol phosphate by using 3² full factorial designs:

Buccal film of carvedilol phosphate was prepared based on the 3² factorial design (3level and 2 factor) using design expert 9.0.2 version software. Drug release of (Y) was selected as response parameter as the dependent variable

Buccal film was prepared by solvent casting method using film forming polymers such as PVA and PVPK-30. Aqueous solution (100ml) of polyvinyl alcohol (PVA) and polyvinyl pyrrolidone prepared separately. Then the solution of PVP was added to PVA solution and mixed well to get clear homogeneous solution and labeled as solution (A). Then accurately weighed quantities of taste masked carvedilol-βCD was dissolved in small quantity of ethanol. PEG200 was added as plasticizer. This solution was labeled as solution (B). The solution B was added to the homogenous aqueous solution A and mixed thoroughly using magnetic stirrer. The obtained solution was casted into a glass petri dish of 9cm diameter (surface area 66.44 sqcm) and allowed to dry for 24h. The film was carefully removed from the petri dish and checked for any imperfection. The resultant film was cut into the dimension of 2cm×2cm in size. The formulation composition of carvedilol phosphate buccal film are given in table1(See Appendix).

Evaluation of carvedilol phosphate buccal film

Taste evaluation:-Taste acceptability of drug and its inclusion complex was measured by a taste panel (n=3). The sample hold in mouth until disintegration, then spat out and the bitterness level was then recorded. Oral cavity was rinsed with sufficiently large amount of distilled water.

Physical appearance and Surface texture:-Physical characterization of film can be carried out by visual inspection for characteristics of transparency and stickiness.

Film weight and film thickness:-All films were weighed on a digital weighing balance and film thickness was measured using vernier callipers from all sides at different position and the average value was noted.

Measurement of pH:-The pH of film formulations was determined by using digital pH meter. Buccal film of size 2x2cm was dissolved in 100 ml of distilled water and kept for 2 h. The measurement of pH of each formulation was done in triplicate and average values were calculated.

Drug content uniformity of the film:-Three films (2×2 cm) of each formulation was taken in separate 100 ml volumetric flask containing pH 6.8 phosphate buffer was added and continuously stirred for 24 h. The solutions were filtered, diluted suitably and

analyzed at 248 nm in a UV spectrophotometer (Shimadzu –Japan1800). The average of three films was taken as final reading.

In vitro drug release:-A standard USP dissolution test apparatus (paddle over disk) apparatus was employed to evaluate drug release. A portion of 2x2 cm² of film was used. The vessel was filled with phosphate buffer pH 6.8 and maintained at 37°C while stirring at 50 rpm. The film was submerged into dissolution medium and aliquot of 5ml samples were collected at predetermined time intervals and replaced with an equal volume. The absorbance was noted using spectrophotometer at 248 nm.

Disintegration time:-The time required to disintegrate was measured by disintegration time. The film was placed in the disintegration test apparatus (Scientific Lab, India) containing phosphate buffer having pH 6.8. Instrument was operated until film gets disintegrated. The time required for disintegration was noted.

Swelling index:-The film was weighed and placed on a pre-weighed cover slip. The cover slip was then submerged in a petridish containing 20 ml phosphate buffer (pH 6.8). Increase in weight of the film was determined at regular time intervals until a constant weight was obtained. The hydration ratio of the film was calculated using following formula.

$$\text{Swelling index (\%)} = \frac{W_t - W_0}{W_0} \times 100$$

Where, W_t was weight of film at time t and W₀ was the original film weight at zero time.

In vitro diffusion study:-Diffusion studies were carried out for the prepared film by Franz diffusion cell with pH 6.8 phosphate buffer using dialysis membrane for a period of 24h. The donor chamber was exposed to air and receiver chamber contained 6.8 pH phosphate buffer solution with dialysis membrane in between. Two ml of solution from receiver chamber was withdrawn at every 5 min till 30 min. and replaced with the aliquot of 2 ml each time. The withdrawn solution was analyzed by UV at 248 nm.

Folding endurance:-Determination of folding endurance of film was done by folding a small strip of film (2x2cm) at the same place repeatedly until it broke. The number of time the film could be folded at the specific place without breaking given the folding endurance value.

Ex vivo drug permeation study:-Ex vivo drug permeation study was carried out by Franz diffusion cell. Goat buccal mucosa obtained from slaughter house was mounted on a diffusion cell between the donor and receptor compartment. The buccal film was fixed on the buccal mucosa. Phosphate buffer of pH 6.8 was filled in receptor compartment. The fluid was maintained at 37 ± 2°C and stirred continuously at 50 ± 2 rpm. Two ml of solution from receiver



chamber was withdrawn at every 3min till 21min, and the aliquot of 2ml was replaced. The withdrawn solution was analyzed by UV at 248 nm.

Stability study:-Formulations with requisite for physical appearance, pH, drug content and drug release were selected for stability. For this, film were packed in aluminum foil labelled and stored studies at 25°C/60% relative humidity and 40°C/75% RH for a period of 30 days. Samples were withdrawn at time intervals of 15 days and evaluated for physical appearance, pH, drug content and drug release.

RESULT AND DISCUSSION

Taste evaluation:-Taste masking was evaluated by human panel volunteers. The prepared complex of carvedilol phosphate with β -cyclodextrin was evaluated. The result shows that excellent taste masking are done.

Physical Appearance and texture of film:-The observation revealed that the films are having the smooth surface, transparent and flexible.

Weight uniformity of film:-The weight variations of film in between 100-138 mg of 2cm² film area.

Surface pH of film :-Surface pH of all film prepared by using polymer was found to be in the range of 6.5 to7, which was closed to the neutral pH, which indicated avoidance irritation to the sublingual mucosa, and hence more acceptable by the patient.

Drug content uniformity:-All the film formulation of carvedilol phosphate showed uniform drug content in the range of 91.95 to 98.74%.

Thickness:-All the film formulations of different polymer concentration are shown in table 3(See Appendix). Thickness of film was found in the range of-0.14±0.0015 to 0.45±0.03mm. A result of thickness measurement showed that the increase in concentration of polymer increased the thickness of film.

Swelling Index: -Formulation F2 containing 4% PVPK30 and 2% PVA showed the more swelling 14.28%. The swellability of the film was found to increase when the hydrophilic polymer content was increased. (Table no 4 See Appendix)

Disintegration time:-Formulations F1to F9 were found to disintegrate within the range of 2 min to 3.36 min. Formulation F2 containing 4% PVP and 2% PVA showed minimal disintegration time 2min,45sec. Formulation F3 showed the more disintegration time 3.32sec.

Folding endurance:-The concentration of polymer & plasticizer increase the folding endurance. The F2 formulation did not show any crack more than 300 time folding. The folding endurance was found to be optimum and film exhibited good physical and mechanical properties. The average value of all film was given in table 3(See Appendix).

In vitro drug dissolution profile:-The formulation F3 show the drug release up to 99.19% by the end of

35 min. The F2 formulation contain hydrophilic polymer PVP K30 4% and PVA 2% .The concentration of hydrophilic polymer increases the rate of drug release. FormulationF7,F8, F9 shows the slow drug release which contains the 3% PVP K30. Formulation F4, F5, F6 give the 83, 76, 74 % respectively contain 5%PVP K30. Formulation F2 and F3 show the complete drug release contain 4% PVPK30. The result are tabulated in table 4(See Appendix) and graph are depicted in figure no 1(See Appendix).

Contour plots, surface plots were drawn using the drawn using the Design-Expert® (version 9.0.3.1) software. These types of plots are useful in study of effects of two factors on the response at one time. The regression coefficient of Y₁ (drug release) are as follow:

$$Y_1 = 93.89 + 7.67 X_1 - 2.33 X_2 + 3.25 X_1 X_2 - 22.33 X_1^2 - 22.33 X_2^2$$

Where Y₁ = Drug release, X₁= conc. of PVP K30, X₂= conc. of PVA

Positive sign before a factor in polynomial equations represents that the response increases with the factor. On the other hand, a negative sign means the response and factors have reciprocal relation.

Contour plot:-Analysis of contour plot of formulation F1 to F9 shown in figure3(See Appendix).Straight lines in contour plots predicted nearly linear relationship of factor. In our study contour plots does not show straight line and this indicates that no linear relation between the factor X₁ and X₂. Figure reveals that the contour area was acceptable with % drug release value above 99% containing 4% PVP K30 and 2% PVA show the higher percent drug release.

Response plot: -Three dimensional response figure 4(See Appendix) reveals that factor X₁ (PVP K30) and X₂ (PVA) effect are evaluated. The High level of factor X₁ shows minimal drug release. The percentage drug release was decreased as the concentration of X₁ was increased.

In vitro drug diffusion:-The *in vitro* diffusion study of formulation F1 to F9 was carried out using modified franz diffusion cell across cellophane membrane using pH 6.8 as medium. The diffusion profiles of formulation F2 contain PVP K 30 4% and PVA 2% showed controlled release as compared to other formulation. Diffusion profile for film F1 to F9 were given in table no. 4(See Appendix) and show in figure no 2(See Appendix).

Stability study:-The formulation was found to be stable for one month at accelerated conditions. There was no significant change in the physical appearance, drug content and in vitro drug release profile of film. No growth of microorganism was observed after completion of one month stability study.



CONCLUSION

Buccal film of carvedilol phosphate prepared by using PVPK 30 and PVA by solvent casting method showed good transparency of film. Bitter taste of carvedilol phosphate was masked using β -CD. Buccal film having 4% PVPK30 and 2% PVA showed faster drug release. The film was found to be stable when exposed for one month stability study. Thus it can be concluded that buccal film of carvedilol phosphate is a very good choice of dosage form for faster onset of action for hypertensive patients.

ACKNOWLEDGMENT

The authors are grateful to the principal and management of Jayawantrao sawant College of Pharmacy and Research, Hadapsar, Pune, for providing all necessary facilities and infra structure to carry out this study. The authors also acknowledge Mylan Pharmaceuticals, Nashik, India, for providing gift sample of Carvedilol phosphate. The authors also acknowledge the help of Mr.Ambawade and Mrs. Vaishali Potnis of Jayawantrao Sawant College of Pharmacy and Research ,Hadapsar,Pune,during experimentation.

REFERENCES

1. Biswas GR, Biswas SM, and Saha SM. Exploring the Effect of polyox on the release kinetics of a model antihypertensive drug from a cellulose derivative based buccal patch. *Research & Review Journal of Pharmacy & Pharmaceutical Science* 2014 April; 3(2):24-31.
2. Kumar A, Phatarpekar V, Pathak N, Padhee K, Garg M and Sharma N. Formulation development & evaluation of carvedilol bioerodable buccal mucoadhesive patches. *International Journal of Compressive Pharmacy* 2011; 3(7):21-27.
3. Gorakh JD, Durgacharan AB, John ID. Formulation and evaluation of fast dissolving buccal patch of olmesartan medoxomil. *Asian Journal of Biomedical And Pharmaceutical Sciences* 2013; 3(21):51-55.
4. Patel N, L Aparna, S Uma, Patil S. Design and characterisation of mucoadhesive buccal patch of glimepiride. *International Journal Pharmacy Pharmaceutical Science* 2012; 2(1):117-128.
5. Tarai M, Meher JG, Patnaik A, Mishra A. Bucco-compatible simvastatin buccal film an integrative study of the effect of formulation variables. *Journal of Scientific and Innovative Research* 2013; 2(5): 903-913.
6. Mohd A, Kamath K, Shabaraya AR, Pillai SS. Formulation and evaluation of fast dissolving tablets of carvedilol using sublimation technique. *International Journal of Research in BioSciences* 2012 July; 1(1): 13-23.
7. <http://www.drugbank.com>
8. Chakraborty P, Dey S, Parcha V, Bhattacharya S, and Ghosh A. Design expert supported mathematical optimization and predictability study of buccoadhesive pharmaceutical wafers of loratadine. *BioMed Research International* 2012; 1-12.
9. Vidyadhara S, Balkrishna T, Sasidhar LC, Showribabu CH, Harika LD. Formulation and evaluation of zolmitriptan fast dissolving buccal film. *Scholars Research Library* 2013; 5(4):145-152.
10. Sarath chandran, Shijith KV, Augusthy AR. Formulation and evaluation of Bisoprolol fumarate buccal patches by using selected polymer 2013; 3(3): 854-860.
11. Mamatha Y, Prasanth V, Selvi V, Mathew ST, Abin A. Formulation and evaluation of mucoadhesive buccal patches of aceclofenac. *Scholars Research Library* 2012; 4 (1):297-306.
12. Mishra S, Kumar G, Kothiyal P. A review article: recent approaches in buccal patches. *The Pharma Innovation* 2012; 1(7):78-86.
13. Swathi G, Rama Devi A, Prasad NLD and Sudheer Babu et al. Salbutamol buccal patches to treat blood pressure. *International Journal Biopharma Research* 2013; 02 (03): 99-103.
14. Pintu KD, Paul J, Dey SK, Dinda SC, Soumen R. Formulation, physico-chemical characterization and release kinetic study of antihypertensive transdermal patches; *Der Pharmacia Sinica*, 2011; 2(5): 98-109.
15. British Pharmacopoeia. London: British pharmacopoeia commission; 2010. P. 387.
16. Satwara R, Patel P. Formulation and optimization of chronomodulated press-coated tablet of carvedilol by Box- Behnken statistical design. *Dove Press journal* 2012; 35-50.
17. Murty KG, V Sai Kishor. Effect of casting solvent on permeability of anti hypertensive drugs through ethyl cellulose film. *Journal of Scientific & Industrial Rresearch* 2008; (67) 147-150.
18. Dhanaraju MD, Senthil kumar KR, Poovi G. Development of mucoadhesive patch for buccal administration of Propranolol hydrochloride. *International Journal of Pharmacy and Medical Sciences* 2011;1(2):16-23.
19. Ranganathan V, Sudhakar Y, Chetty M et al. Buccal drug delivery from carvedilol polymeric muco adhesive film. *International Journal of Pharmacy Research* 2011; 4(11):3897-3901.
20. Vijayasri K, Rohini P, Reddy KG. Montelukast sodium oral thin films formulation and invitro evaluation. *Asian Journal Pharmacy Clinical Research* 2012; 5(4): 266-270.

**APPENDIX**

Factor	Level used		
	Low (-1)	Medium (0)	High (+)
X ₁ -Concentratio of polyvinyl pyrrolidone K30 (gm)	3	4	5
X ₂ -Concentration of polyvinyl alcohol (gm)	1	2	3

Table no.1 Factorial design parameters

Ingredients	F1	F2	F3	F4	F5	F6	F7	F8	F9
Carvedilol phosphate	3	3	3	3	3	3	3	3	3
PVP K30 (%)w/v	4	4	4	5	5	5	3	3	3
PVA(%) w/v	3	2	1	3	2	1	3	2	1
Saccharine sodium(mg)	20	20	20	20	20	20	20	20	20
PEG400(ml)	0.5	0.5	0.5	0.5	0.5	0.5	0.5	0.5	0.5
Ethanol (ml)	5	5	5	5	5	5	5	5	5

Table no.2 Composition of different formulation film

Sr.no	Volunteers	Pure drug (Carvedilol)	Complex (carvedilol+βcyclodextrin)
1	V1	+	++
2	V2	+	++++
3	V3	+	++++

+ = Bitter, ++ =Taste masked, +++++ = Excellent taste masking

Table no.3 Taste masking evaluation report



Parameter	F1	F2	F3	F4	F5	F6	F7	F8	F9
Weight variation	128	100	120	138	126	127	132	130	128
Thickness (mm)	0.16	0.23	0.17	0.45	0.20	0.16	0.14	0.15	0.20
Drug content (%)	98.10	98.74	97.1	96.7	96.49	96.02	95.00	95.12	91.95
Disintegration time	2.86	2.75	2.71	3.60	3.16	2.84	3.33	3.00	2.91
Folding endurance	300	>300	300	283	285	300	216	250	242

Table no.4 Evaluation values of prepared films

Parameter	F1	F2	F3	F4	F5	F6	F7	F8	F9
Swelling index(%)	10.34	14.28	13.59	14.19	10.40	11.37	8.06	9.61	7.62
Moisture loss (%)	1.36	1.91	2.75	3.43	1.93	2.71	3.90	2.88	2.68
% drug dissolution	80.59	98.98	99.19	83.74	76.46	73.97	60.78	63.70	64.91
% drug diffusion	82.55	91.53	90.23	84.59	77.10	74.38	62.34	57.38	59.38

Table no.5 Evaluation values of prepared films

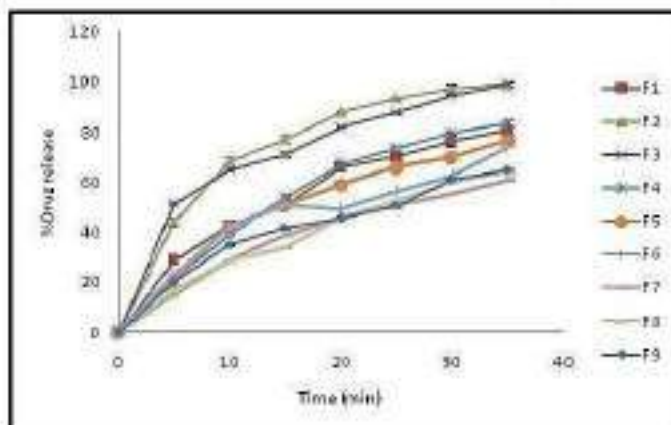

Fig.1 In vitro drug dissolution study

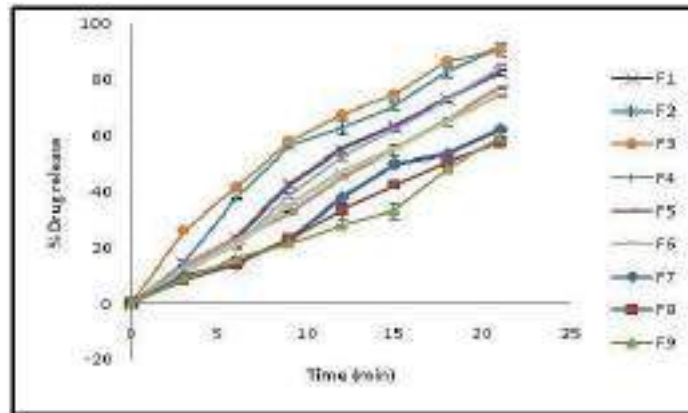

Fig.2 In vitro drug diffusion profile through cellophane membrane

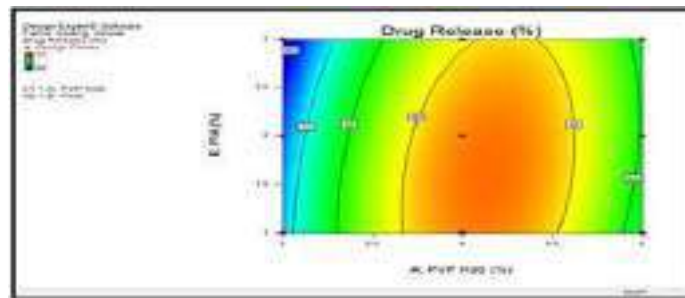

Fig.3 Two-dimensional contour plot

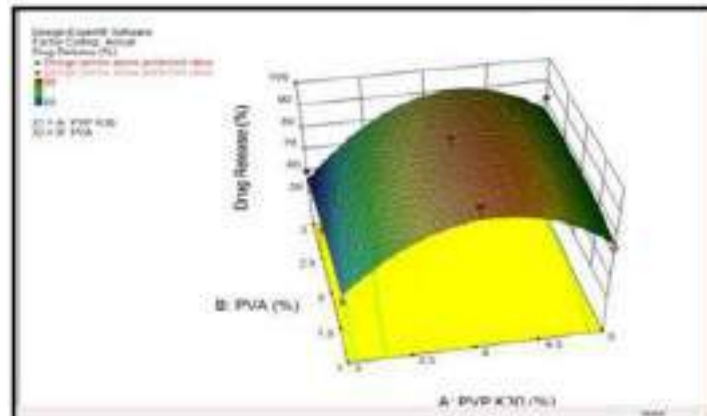

Fig. 4 Three dimensional response surface plots



DATABASE MANAGEMENT FOR FACIAL RECOGNITION SYSTEM

Sk. Naveed¹

*¹ Department of Computer Science and Engineering, Koneru Lakshmaiah Education Foundation,
Vaddeswaram-522502, Guntur, AP, India*

N.Ramya²

*² Department of Computer Science and Engineering, Koneru Lakshmaiah Education Foundation,
Vaddeswaram-522502, Guntur, AP, India*

D.Manasa³

*³ Department of Computer Science and Engineering, Koneru Lakshmaiah Education Foundation,
Vaddeswaram-522502, Guntur, AP, India*

N. Ramya Sri⁴

*⁴ Department of Computer Science and Engineering, Koneru Lakshmaiah Education Foundation,
Vaddeswaram-522502, Guntur, AP, India*

Article DOI: <https://doi.org/10.36713/epra5585>

ABSTRACT

The face is one of the easiest ways to differentiate the individual identity of each other. Face recognition is a personal identification system that uses personal characteristics or facial features of a person to identify the person's identity. The most used human face recognition process is face detection, where this procedure takes place very quickly in humans, except under certain conditions where the object is located at close distance. The purpose of this project is to develop face recognition based automated student attendance system. In order to achieve high quality performance, the test images and training images of this proposed approach are limited to frontal and upright facial images that consist of a single face only. The test images and training images have to be captured by using the same device to ensure no quality difference. In addition, the students have to register in the database to be recognized. The enrolment can be done on the spot through the user-friendly interface.



INTRODUCTION

The enhancement of science and technology leads to make the life more comfortable than older days. The emerging technologies like neutrosophic shortest path [1,2,3,4,5], transportation problem [6,7,8], uncertainty problem [9,10,11,12,13,14], fuzzy shortest path [15,16,17,18,19], PowerShell [20], wireless sensor network [21,22,23,24,25,26,27,28], computer language [29,30], neural network [31], routing [32] making the products more intelligent and self-healing based. The smart city applications like smart water, smart grid, smart parking, smart resource management, etc. are based on IoT and IoE [33,34, 35, 36] technologies. We have the development available to us to enable the organization of our consistently lives and the sharing of significant information with our associates, families and others. Why development is huge in our consistently life. It is a basic contraption that we can't avoid, it has a huge impact in the vast majority of our lives. Technology fundamentally handles the instruments, advancements and strategies used to help us with dealing with issues and simply improve our everyday schedules and easier to encounter to a great extent [37,38]. Advancement is inevitable in our normal everyday presences [39]. This is in light of the fact that presence without advancement is senseless in the present incredible world. Development, which joins instruments to propel unforeseen development, use and information exchange, has as its basic objective of making tasks easier and the handling of various issues of mankind. Right when development advances and makes our continues with extensively more worthwhile, we should pressure that it is so useful to our lives.

Face recognition is the process of identifying an already detected object as a known or unknown face. Face recognition technology is gradually evolving to a global biometric technique since it requires zero effort from the user end while compared with other biometric methods. In spite of the fact that other techniques of identification such as fingerprints, or iris scanning can be more accurate, face recognition has always remains

a major focus of research because of its non-invasive nature and because it is people's basic method of person identification. The purpose of this project is to develop the process of face recognition based automated student attendance system. Commonly, student's attendances are taken manually by using attendance register given by the faculty members in class, which is a time consuming event. Moreover, it is very difficult to check one by one student in a large classroom environment with distributed branches whether the authenticated students are actually responding or not. So, why not make it automated quickly and much efficient.

DIGITAL IMAGE IN DATABASE

Face recognition basically requires a database to store a number of pictures. Human face recognition is based on face detection because in order to identify a person's in a picture, face recognition method has to locate the people's face in the picture. Human face recognition compares the similarity between the captured pictures of the student with the pictures of the student within the database and finds the most similar students. It is processed by capturing the video of the students, convert it into frames, and relate it with the database to ensure their presence or absence, mark attendance to the particular student to maintain the records.

There are three major steps:

1. To find a good database of faces with multiple images for each individual.
2. To detect faces in the database images and use them to train the face recognizer.
3. Test the face recognizer to recognize faces it was trained for.

To perform the process of face detection, there must be a database which consists of student images in gif format. There will be 11 images for each individual. In each image, each individual student has a different facial expression like happy, sad, normal, surprised, sleepy etc.

**Fig.1 Samples of image**

We will use database by using to store different number of images of the total images of each individual student in training our face recognizer and the single image of each student individual to test our face recognition algorithm.

They are different types of image processing

1. Low level
2. Medium level
3. High level

Low level processing means performing main operations on images such as Scanning an image resize, rotate image, RGB to gray level conversion etc, The output of an image obtained after low level processing is fresh image. Medium level processing means extracting regions of interest from output of low level processed image. It deals with identification of edges. This process is also called as segmentation. High level processing deals with adding of artificial intelligence to medium level processed signal.

ELEMENTS OF DIGITAL IMAGE PROCESSING

The basic operations performed in a digital image processing are:

- Acquisition
- Storage
- Processing
- Communication
- Display

CONCLUSION

The aim of this Project is to capture the video of the students, convert it into frames, relate it with the database to ensure their presence or absence, mark attendance to the particular student to maintain the record.

REFERENCES

1. Broumi, S., Dey, A., Talea, M. et al. Shortest path problem using Bellman algorithm under

neutrosophic environment. *Complex & Intelligent Systems*, 5 (2019), 409-416.

2. Kumar, R., Dey, A., Broumi, S., and Smarandache, F. A study of neutrosophic shortest path problem. In *Neutrosophic Graph Theory and Algorithms*. IGI Global, 2020.
3. Kumar, R., Edalatpanah, S. A., Jha, S., Broumi, S., Singh, R., and Dey, A. A multi objective programming approach to solve integer valued neutrosophic shortest path problems. *Neutrosophic Sets and Systems*, 24 (2019), 139-151.
4. Kumar, R., Edalatpanah, S. A., Jha, S., and Singh, R. A novel approach to solve gaussian valued neutrosophic shortest path problems. *International Journal of Engineering and Advanced Technology*, 8 (2019), 347-353.
5. Kumar, R., Edalatpanah, S. A., Jha, S., Broumi, S., and Dey, A. Neutrosophic shortest path problem. *Neutrosophic Sets and Systems*, 23 (2018), 5-15.
6. Pratihari, J., Kumar, R., Dey, A., and Broumi, S. Transportation problem in neutrosophic environment. In *Neutrosophic Graph Theory and Algorithms*. IGI Global, 2020.
7. Kumar, R., Edalatpanah, S. A., Jha, S., and Singh, R. A Pythagorean fuzzy approach to the transportation problem. *Complex & Intelligent Systems*, 5 (2019), 255-263.
8. Pratihari, J., Kumar, R., Edalatpanah, S. A., and Dey, A. Modified Vogel's approximation method for transportation problem under uncertain environment. *Complex & Intelligent Systems* (2020), 1-12.
9. Gayen, S., Jha, S., Singh, M., and Kumar, R. On a generalized notion of anti-fuzzy subgroup and some characterizations. *International Journal of Engineering and Advanced Technology*, 8 (2019), 385-390.
10. Gayen, S., Smarandache, F., Jha, S., and Kumar, R. Interval-valued neutrosophic subgroup based on interval-valued triple t-norm. In *Neutrosophic Sets in Decision Analysis and Operations Research*. IGI Global, 2020.



11. Gayen, S., Smarandache, F., Jha, S., Singh, M. K., Broumi, S., and Kumar, R. Introduction to plithogenic subgroup. In *Neutrosophic graph Theory and Algorithms*. IGI Global, 2020.
12. Gayen, S., Smarandache, F., Jha, S., Singh, M. K., Broumi, S., and Kumar, R. Soft Subring Theory Under Interval-valued Neutrosophic Environment. *Neutrosophic Sets and Systems*, 36 (2020), 16.
13. Gayen, S., Smarandache, F., Jha, S., and Kumar, R. Introduction to interval-valued neutrosophic subring. *Neutrosophic Sets and Systems*, 36 (2020), 17.
14. Gayen, S., Smarandache, F., Jha, S., Singh, M. K., Broumi, S., and Kumar, R. Introduction to plithogenic hypersoft subgroup. *Neutrosophic Sets and Systems*, 33 (2020), 208-233.
15. Kumar, R., Edalatpanah, S. A., and Mohapatra, H. Note on ``Optimal path selection approach for fuzzy reliable shortest path problem``. *Journal of Intelligent & Fuzzy Systems* (2020), 1-4.
16. Kumar, R., Jha, S., and Singh, R. A different approach for solving the shortest path problem under mixed fuzzy environment. *International Journal of Fuzzy System Applications*, 9 (2020), 132-161.
17. Kumar, R., Jha, S., and Singh, R. Shortest path problem in network with type-2 triangular fuzzy arc length. *Journal of Applied Research on Industrial Engineering*, 4 (2017), 1-7.
18. Kumar, Ranjan, Edalatpanah, S. A., Jha, Sripati, Gayen, Sudipta, and Singh, Ramayan. Shortest path problems using fuzzy weighted arc length. *International Journal of Innovative Technology and Exploring Engineering*, 8 (2019), 724-731.
19. Kumar, R., Edalatpanah, S. A., Jha, S., Gayen, S., and Singh, R. Shortest path problems using fuzzy weighted arc length. *International Journal of Innovative Technology and Exploring Engineering*, 8 (2019), 724-731.
20. Mohapatra, H., Panda, S., Rath, A. K., Edalatpanah, S. A., and Kumar, R. A tutorial on powershell pipeline and its loopholes. *International Journal of Emerging Trends in Engineering Research*, 8 (2020), 975-982.
21. Mohapatra, H., Rath, S., Panda, S., and Kumar, R. Handling of man-in-the-middle attack in wsn through intrusion detection system. *International Journal of Emerging Trends in Engineering Research*, 8 (2020), 1503-1510.
22. Mohapatra, H., Debnath, S., and Rath, A. K. Energy management in wireless sensor network through eb-leach. *International Journal of Research and Analytical Reviews*, 56 (2018), 56-61.
23. Mohapatra, H., Rath, A. K., Landge, P. B., Bhise, D., Panda, S., and Gayen, S. A comparative analysis of clustering protocols of wireless sensor network. *International Journal of Mechanical and Production Engineering Research and Development*, 10 (2020), 8371-8386.
24. Mohapatra, H. and Rath, A. K. A survey on fault tolerance based clustering evolution in wsn. *IET Networks* (2020).
25. Mohapatra, H., Debnath, S., Rath, A. K., Landge, P. B., Gayen, S., and Kumar, R. An efficient energy saving scheme through sorting technique for wireless sensor network. *International Journal of Emerging Trends in Engineering Research*, 8 (2020), 4278-4286.
26. Mohapatra, H. and Rath, A. K. Fault tolerance in wsn through uniform load distribution function. *International Journal of Sensors, Wireless Communications and Control*, 10 (2020).
27. Mohapatra, H. and Rath, A. K. Fault tolerance through energy balanced cluster formation (ebcf) in wsn. In *Smart Innovations in Communication and Computational Sciences (2018)*, springer, 313-321.
28. Mohapatra, Hitesh and Rath, Amiya Kumar. Fault tolerance in WSN through PE-LEACH protocol. *IET Wireless Sensor Systems*, 9, 6 (Dec. 2019), 358-365(7).
29. Mohapatra, H. C Programming: Practice. Amazon, 2018.
30. Mohapatra, H. and Rath, A. K. *Fundamentals of Software Engineering*. BPB, 2020.
31. Mohapatra, H. *HCR by Using Neural Network*. 2009.
32. Panda, M., Pradhan, P., Mohapatra, H., and Barpanda, N. K. Fault tolerant routing in heterogeneous environment. *International Journal of Scientific & Technology Research*, 8 (2019), 1009-1013.
33. Mohapatra, H. Offline drone instrumentalized ambulance for emergency situations. *International Journal of Robotics and Automation*, 9 (2020), 251-255.
34. Mohapatra, H. and Rath, A. K. Detection and avoidance of water loss through municipality taps in india by using smart tap and ict. *IET Wireless Sensor Systems* (2019), <https://doi.org/10.1049/iet-wss.2019.00000>.
35. Panda, H., Mohapatra, H., and Rath, A. K. Wsn-based water channelization: an approach of smart water. In *Smart Cities: Opportunities and Challenges*. Springer, Singapore, 2020.
36. Rout, S. S., Mohapatra, H., Nayak, R. K., Tripathy, R., Bhise, D., Patil, S. P., and Rath, A. K. Smart water solution for monitoring of water usage based on weather condition. *International Journal of Engineering and Technical Research*, 8 (2020), 5335-5343.



TESTING OF MODULES FOR FACIAL RECOGNITION

N.Ramya¹

¹*Department of Computer Science and Engineering, Koneru Lakshmaiah Education Foundation, Vaddeswaram-522502, Guntur, AP, India*

D.Manasa²

²*Department of Computer Science and Engineering, Koneru Lakshmaiah Education Foundation, Vaddeswaram-522502, Guntur, AP, India*

N.Ramya Sri³

³*Department of Computer Science and Engineering, Koneru Lakshmaiah Education Foundation, Vaddeswaram-522502, Guntur, AP, India*

Sk.Naveed⁴

⁴*Department of Computer Science and Engineering, Koneru Lakshmaiah Education Foundation, Vaddeswaram-522502, Guntur, AP, India*

Article DOI: <https://doi.org/10.36713/epra5586>

ABSTRACT

Face is the crucial part of the human body that uniquely identifies a person. Using the face characteristics as biometric, the face recognition system can be implemented. The most demanding task in any organization is attendance marking. In traditional attendance system, the students are called out by the teachers and their presence or absence is marked accordingly. However, these traditional techniques are time consuming and tedious. In this project, the Open CV based face recognition approach has been proposed. This model integrates a camera that captures an input image, an algorithm for detecting face from an input image, encoding and identifying the face, marking the attendance in a spreadsheet and converting it into PDF file. The training database is created by training the system with the faces of the authorized students. The cropped images are then stored as a database with respective labels. The features are extracted using LBPH algorithm.

INTRODUCTION

Attendance maintenance is a significant function in all the institutions to monitor the performance of the students. Every institute does this in its own way. Some of these institutes use the old paper or file based

systems and some have adopted strategies of automatic attendance using some biometric techniques. A facial recognition system is a computerized biometric software which is suited for determining or validating a person by performing comparison on patterns based on



their facial appearances. Face recognition systems have upgraded appreciably in their management over the recent years and this technology is now vastly used for various objectives like security and in commercial operations. Face recognition is a powerful field of research which is a computer based digital technology. Face recognition for the intent of marking attendance is a resourceful application of attendance system. It is widely used in security systems and it can be compared with other biometrics such as fingerprint or eye iris recognition systems. As the number of students in an educational institute or employees at an organization increases, the needs for lecturers or to the organization also increase the complication of attendance control. This project may be helpful for the explanation of these types of problems. The number of students present in a lecture hall is observed, each person is identified and then the information about the number of students who are present is maintained.

The enhancement of science and technology leads to make the life more comfortable than older days. The emerging technologies like neutrosophic shortest path [1,2,3,4,5], transportation problem [6,7,8], uncertainty problem [9,10,11,12,13,14], fuzzy shortest path [15,16,17,18,19], PowerShell [20], wireless sensor network [21,22,23,24,25,26,27,28], computer language [29,30], neural network [31], routing [32] making the products more intelligent and self-healing based. The smart city applications like smart water, smart grid, smart parking, smart resource management, etc. are based on IoT and IoE [33,34, 35, 36] technologies. We have the development available to us to enable the organization of our consistently lives and the sharing of significant information with our associates, families and others. Why development is huge in our consistently life. It is a basic contraption that we can't avoid, it has a huge impact in the vast majority of our lives. Technology fundamentally handles the instruments, advancements and strategies used to help us with dealing with issues and simply improve our everyday schedules and easier to encounter to a great extent [37,38]. Advancement is inevitable in our normal everyday presences [39]. This is in light of the fact that presence without advancement is senseless in the present incredible world. Development, which joins instruments to propel unforeseen development, use and information exchange, has as its basic objective of making tasks easier and the handling of various issues of mankind. Right when development advances and makes our continues with extensively more worthwhile, we should pressure that it is so useful to our lives.

ALGORITHM

There are various algorithms used for facial recognition. Some of them are as follows: 1. Eigen faces 2. Fisher faces 3. Local binary patterns histograms

1. EIGEN FACES This method is a statistical plan. The characteristic which influences the images is derived by this algorithm. The whole recognition method will depend on the training database that will be provided. The images from two different classes are not treated individually.

2. FISHER FACES Fisher faces algorithm also follows a progressive approach just like the Eigen faces. This method is an alteration of Eigen faces so it uses the same principal Components Analysis. The major conversion is that the Fisher faces considers the classes. As mentioned previously, the Eigen faces does not differentiate between the two pictures from two different classes while training. The total average affects each picture. A Fisher face employs Linear Discriminant Analysis for distinguishing between pictures from a different class.

3. LOCAL BINARY PATTERNS HISTOGRAMS This method needs the gray scale pictures for dealing with the training part. This algorithm in comparison to other algorithms is not a holistic approach.

- I. PARAMETERS: LBPH uses the following parameters:
 - i. Radius: Generally 1 is set as a radius for the circular local binary pattern which denotes the radius around the central pixel.
 - II. Neighbors: The number of sample points surrounding the central pixel which is generally 8. The computational cost will increase with increase in number of sample points.
 - III. Grid X: The number of cells along the horizontal direction is represented as Grid X. With the increase in number of cells the grid becomes finer which results in increase of dimensional feature vector.
 - IV. Grid Y: The number of cells along the vertical direction is represented as Grid Y. With the increase in number of cells the grid becomes finer which results in increase of dimensional feature vector.

B. ALGORITHM TRAINING

For the training purpose of the dataset of the facial images of the people to be recognized along with the unique ID is required so that the presented approach will utilize the provided information for perceiving an



input image and providing the output. Same images require same ID.

C. COMPUTATION OF THE ALGORITHM

The intermediate image with improved facial characteristics which corresponds to the original image is created in the first step. Based on the parameters provided, sliding window theory is used in order to achieve so. Facial image is converted into gray scale. A 3x3 pixels window is taken which can also be expressed as a 3x3 matrix which contains the intensity of each pixel (0-255). After this we consider the central value of the matrix which we take as the threshold. This value defines the new values obtained from the 8 neighbours. A new binary value is set for each neighbour of the central value. For the values equal to or greater than the threshold value 1 will be the output otherwise 0 will be the output. Only binary values will be present in the matrix and the concatenation is performed at each position to get new values at each position. Then the conversion of this binary value into a decimal value is done which is made the central value of the matrix. It is a pixel of the actual image. As the process is completed, we get a new image which serves as the better characteristics of the original image. D. EXTRACTION OF HISTOGRAM: The image

obtained in the previous step uses the Grid X and Grid Y parameters and the image is split into multiple grids. Based on the image the histogram can be extracted as below: 1. The image is in gray scale and each histogram will consist of only 256 positions (0-255) which symbolises the existences of each pixel intensity. 2. After this each histogram is created and a new and bigger histogram is done. Let us suppose that there are 8x8 grids, then there will be 16.384 positions in total in the final histogram.

Face Recognition

The training of the algorithm is done. For finding the image which is same as the input image, the two histograms are compared and the image corresponding to the nearest histogram is returned. Different approaches are used for the calculation of distance between the two histograms. Here we use the Euclidean distance based on the formula: Hence the result of this method is the ID of the image which has the nearest histogram. It should return the distance calculated in the form of 'confidence'. Then the threshold and the 'confidence' can be used to automatically evaluate if the image is correctly recognized. If the confidence is less than the given threshold value, it implies that the image has been well recognized by the algorithm.

ACE	FACE	
Confidence factor based on output is 2,000-3,000.	It is 100-400.	
Threshold value is 4,000.	Threshol value d is 400	Threshold value is 7.
Principle of dataset generation is component based.	It is component based.	It is pixel based.
Basic principle is PCA.	Basic principle is LDA.	Basic principle is Histogram.
Background noise is maximum.	Background noise is medium.	Background noise is minimum.
Efficiency is minimum.	Efficiency is Greater than Eigen face.	Efficiency is maximum.

Table 1. Comparison of LBPH with other algorithms

**Fig.1 User Interface for proposed model**

CONCLUSION

The conclusion of the project is the most productive Open CV face recognition method accessible for Attendance Management. The system has been implemented using algorithm. It excels other algorithms by confidence factor of 2-5 and has least noise interference. The implementation of the Smart Attendance System portrays the existence of an agreement between the appropriate recognition rate and the threshold value. Therefore is the most authentic and competent face recognition algorithm found in Open CV for the identification of the students in an educational institute and marking their attendance adequately by averting proxies?

REFERENCES

1. Broumi, S., Dey, A., Talea, M. et al. Shortest path problem using Bellman algorithm under neutrosophic environment. *Complex & Intelligent Systems*, 5 (2019), 409-416.
2. Kumar, R., Dey, A., Broumi, S., and Smarandache, F. A study of neutrosophic shortest path problem. In *Neutrosophic Graph Theory and Algorithms*. IGI Global, 2020.
3. Kumar, R., Edalatpanah, S. A., Jha, S., Broumi, S., Singh, R., and Dey, A. A multi objective programming approach to solve integer valued neutrosophic shortest path problems. *Neutrosophic Sets and Systems*, 24 (2019), 139-151.
4. Kumar, R., Edalatpanah, S. A., Jha, S., and Singh, R. A novel approach to solve gaussian valued neutrosophic shortest path problems. *International Journal of Engineering and Advanced Technology*, 8 (2019), 347-353.
5. Kumar, R., Edalatpanah, S. A., Jha, S., Broumi, S., and Dey, A. Neutrosophic shortest path problem. *Neutrosophic Sets and Systems*, 23 (2018), 5-15.
6. Pratihari, J., Kumar, R., Dey, A., and Broumi, S. Transportation problem in neutrosophic environment. In *Neutrosophic Graph Theory and Algorithms*. IGI Global, 2020.
7. Kumar, R., Edalatpanah, S. A., Jha, S., and Singh, R. A Pythagorean fuzzy approach to the transportation problem. *Complex & Intelligent Systems*, 5 (2019), 255-263.
8. Pratihari, J., Kumar, R., Edalatpanah, S. A., and Dey, A. Modified Vogel's approximation method for transportation problem under uncertain environment. *Complex & Intelligent Systems* (2020), 1-12.
9. Gayen, S., Jha, S., Singh, M., and Kumar, R. On a generalized notion of anti-fuzzy subgroup and some characterizations. *International Journal of Engineering and Advanced Technology*, 8 (2019), 385-390.
10. Gayen, S., Smarandache, F., Jha, S., and Kumar, R. Interval-valued neutrosophic subgroup based on interval-valued triple t-norm. In *Neutrosophic Sets in Decision Analysis and Operations Research*. IGI Global, 2020.
11. Gayen, S., Smarandache, F., Jha, S., Singh, M. K., Broumi, S., and Kumar, R. Introduction to plithogenic subgroup. In *Neutrosophic graph Theory and Algorithms*. IGI Global, 2020.
12. Gayen, S., Smarandache, F., Jha, S., Singh, M. K., Broumi, S., and Kumar, R. Soft Subring Theory Under Interval-valued Neutrosophic Environment. *Neutrosophic Sets and Systems*, 36 (2020), 16.
13. Gayen, S., Smarandache, F., Jha, S., and Kumar, R. Introduction to interval-valued neutrosophic subring. *Neutrosophic Sets and Systems*, 36 (2020), 17.
14. Gayen, S., Smarandache, F., Jha, S., Singh, M. K., Broumi, S., and Kumar, R. Introduction to plithogenic hypersoft subgroup. *Neutrosophic Sets and Systems*, 33 (2020), 208-233.
15. Kumar, R., Edalatpanah, S. A., and Mohapatra, H. Note on "Optimal path selection approach for



- fuzzy reliable shortest path problem`. *Journal of Intelligent & Fuzzy Systems* (2020), 1-4.
16. Kumar, R., Jha, S., and Singh, R. A different approach for solving the shortest path problem under mixed fuzzy environment. *International Journal of Fuzzy System Applications*, 9 (2020), 132-161.
 17. Kumar, R., Jha, S., and Singh, R. Shortest path problem in network with type-2 triangular fuzzy arc length. *Journal of Applied Research on Industrial Engineering*, 4 (2017), 1-7.
 18. Kumar, Ranjan, Edalatpanah, S. A., Jha, Sripati, Gayen, Sudipta, and Singh, Ramayan. Shortest path problems using fuzzy weighted arc length. *International Journal of Innovative Technology and Exploring Engineering*, 8 (2019), 724-731.
 19. Kumar, R., Edalatpanah, S. A., Jha, S., Gayen, S., and Singh, R. Shortest path problems using fuzzy weighted arc length. *International Journal of Innovative Technology and Exploring Engineering*, 8 (2019), 724-731.
 20. Mohapatra, H., Panda, S., Rath, A. K., Edalatpanah, S. A., and Kumar, R. A tutorial on powershell pipeline and its loopholes. *International Journal of Emerging Trends in Engineering Research*, 8 (2020), 975-982.
 21. Mohapatra, H., Rath, S., Panda, S., and Kumar, R. Handling of man-in-the-middle attack in wsn through intrusion detection system. *International Journal of Emerging Trends in Engineering Research*, 8 (2020), 1503-1510.
 22. Mohapatra, H., Debnath, S., and Rath, A. K. Energy management in wireless sensor network through eb-leach. *International Journal of Research and Analytical Reviews*, 56 (2018), 56-61.
 23. Mohapatra, H., Rath, A. K., Landge, P. B., Bhise, D., Panda, S., and Gayen, S. A comparative analysis of clustering protocols of wireless sensor network. *International Journal of Mechanical and Production Engineering Research and Development*, 10 (2020), 8371-8386.
 24. Mohapatra, H. and Rath, A. K. A survey on fault tolerance based clustering evolution in wsn. *IET Networks* (2020).
 25. Mohapatra, H., Debnath, S., Rath, A. K., Landge, P. B., Gayen, S., and Kumar, R. An efficient energy saving scheme through sorting technique for wireless sensor network. *International Journal of Emerging Trends in Engineering Research*, 8 (2020), 4278-4286.
 26. Mohapatra, H. and Rath, A. K. Fault tolerance in wsn through uniform load distribution function. *International Journal of Sensors, Wireless Communications and Control*, 10 (2020).
 27. Mohapatra, H. and Rath, A. K. Fault tolerance through energy balanced cluster formation (ebcf) in wsn. In *Smart Innovations in Communication and Computational Sciences* (2018), springer, 313-321.
 28. Mohapatra, Hitesh and Rath, Amiya Kumar. Fault tolerance in WSN through PE-LEACH protocol. *IET Wireless Sensor Systems*, 9, 6 (Dec. 2019), 358-365(7).
 29. Mohapatra, H. C *Programming: Practice*. Amazon, 2018.
 30. Mohapatra, H. and Rath, A. K. *Fundamentals of Software Engineering*. BPB, 2020.
 31. Mohapatra, H. *HCR by Using Neural Network*. 2009.
 32. Panda, M., Pradhan, P., Mohapatra, H., and Barpanda, N. K. Fault tolerant routing in heterogeneous environment. *International Journal of Scientific & Technology Research*, 8 (2019), 1009-1013.
 33. Mohapatra, H. Offline drone instrumentalized ambulance for emergency situations. *International Journal of Robotics and Automation*, 9 (2020), 251-255.
 34. Mohapatra, H. and Rath, A. K. Detection and avoidance of water loss through municipality taps in india by using smart tap and ict. *IET Wireless Sensor Systems* (2019), <https://doi.org/10.1049/iet-wss.2019.0000>.
 35. Panda, H., Mohapatra, H., and Rath, A. K. Wsn-based water channelization: an approach of smart water. In *Smart Cities: Opportunities and Challenges*. Springer, Singapore, 2020.
 36. Rout, S. S., Mohapatra, H., Nayak, R. K., Tripathy, R., Bhise, D., Patil, S. P., and Rath, A. K. Smart water solution for monitoring of water usage based on weather condition. *International Journal of Engineering and Technical Research*, 8 (2020), 5335-5343.



A STUDY ON FACTORS AFFECTING CUSTOMER'S INVESTMENT TOWARDS LIFE INSURANCE POLICIES OF LIC IN COIMBATORE CITY

Dr. S. Suguna

*Associate Professor, Department of commerce with professional Accounting,
Dr. N.G.P. Arts and Science College, Coimbatore*

P. Ramya

*Student of III B.Com.(PA), Department of commerce with professional Accounting,
Dr. N.G.P. Arts and Science College, Coimbatore*

ABSTRACT

The Life Insurance Corporation of India plays an important role in providing insurance protection against death and old age on the one hand and accelerating the growth of our economy. This is obvious because of the fact that the life insurance touches every section of the society privileged and under privileged, agricultural and industrial labour employed and self-employed etc. and provides economic security to all and sundry. The Life Insurance Corporation of India is an important constituent of India's capital market. It collects huge funds for the public and invests them in agriculture, industry, transport and in a number of other economic activities.

INTRODUCTION

Life insurance is a must for everyone because life is very precious. With a population of over one billion, national and international life insurance companies, see India as a land of opportunities and a market for big business. Until 1999, the business of life insurance in India was the monopoly of life insurance Corporation of India (lic). Privatization witnessed dynamic changes in the insurance industry and most of the private insurance companies are joint ventures with recognized foreign players across the globe. Customers are the main pillar of life insurance business. Since customers are becoming more demanding and complex, therefore, it is important for the insurance companies to understand the factors which are significant to the customers for purchasing of insurance plans. Since customers are becoming more demanding and complex, therefore, it is important for the insurance companies to understand the factors which are significant to the customers for purchasing of insurance plans.

STATEMENT OF THE PROBLEM

The Life Insurance Industry has been a dynamic one ever since the gates were thrown open

to the private players. This study has been carried out to find out the factors influencing the selection process of an insurance product that would help the company to develop their marketing strategy. A lot has happened in product innovation, product training, customer focus etc. This study gives information about the market contacts, motivational factors that might influence the customer's decision to buy an insurance product which would serve as basic information for the company to understand the customer's requirements and to meet out their needs effectively. The company has to initiate further development to fine tune the policy formulation to gear up the business. Increase in sale of insurance products of the insurance company is based on the decision process of the customer in selecting an insurance marketing.

OBJECTIVES OF THE STUDY

- To study the factors affecting customers' preferences towards life insurance products.
- To know the satisfaction level of customers with respect to issuers.
- To analyze the purchase decision-making patterns of life insurance customers.



- To examine the attribute the customers prefer while purchasing the life insurance policy.

TOOLS USED FOR ANALYSIS

The primary data were collected, tabulated and analyzed. The statistical tools used for analysis of the study are;

- Simple Percentage Analysis
- Likert Scale Analysis

LIMITATION OF THE STUDY

The following are the limitations of the study;

- Based on the time constraints only 120 respondents were collected
- The result of the study is applicable for Coimbatore city only
- This study covers only the Life Insurance Policy holders of LIC

REVIEW OF LITERATURE

Rao (2014) Explained that liberalisation of the financial services sectors has led to insurance companies functioning increasingly under competitive pressures; so companies are directing towards increasing customer satisfaction and loyalty. This study is an endeavour to examine and evaluate the various CRM initiatives in life insurance companies and compare the strategies used by public sector LIC with private sector companies.

Mayakkannan Raman (2018) this study explores satisfaction level of customers towards Life Insurance Corporation in Chennai city. Due to increasing awareness among people about their uncertainty of life and increasing competition in Insurance Sector, it is significant for Insurance Companies to understand the requisite of their customers. The main aim of the study is based on primary data which is collected through questionnaire among 150 policyholders in Chennai and data were analyzed with multi variety statistical tools like percentage.

DATA ANALYSIS AND INTERPRETATION

In this chapter the analysis and interpretation of "A study on customers satisfaction towards investment on life insurance with special reference to Coimbatore city is presented based on the opinion of sample of 120 respondents selected from Coimbatore city through a questionnaire containing 23 question is where analysed through 2 different tools and there are as follows,

- Simple percentage analysis
- Likert scale analysis

PERCENTAGE ANALYSIS

The data gathered for the study is also presented in terms of percentage. The percentages are calculated to the total of the subject. In the chapter were analysis and interpretation.

FORMULA

$$\frac{\text{Number of respondents}}{\text{Total number of respondents}} * 100$$

Table 4.1.1
AGE OF THE RESPONDENTS

S. No	Age	No. of Respondents	Percentage
1	Below 20	14	12
2	21 - 30	52	43
3	31 - 40	31	26
4	Above 40	23	19
	Total	120	100

INTERPRETATION

From the above table it reveals that, 12% of the respondents are below the age of 20 years,

43% of the respondents are 21-30 years, and 26% of the respondents' are 31-40 years and 19% of the respondents are above 40 years.

Table 4.1.2
GENDER OF THE RESPONDENTS

S.N O	Gender	No.of Respondent	Percentage
1	Male	64	53
2	Female	56	47
	Total	120	100

INTERPRETATION

From the above table it shows that 53% of the respondents are male and 47% of the respondents are female.

Table 4.1.3
MARITAL STATUS OF THE RESPONDENTS

S. No	Married Status	No. of Respondents	Percentage
1	Married	88	73
2	Unmarried	32	27
	Total	120	100



INTERPRETATION

From the above table it reveals that 73% of the respondents are married and 27% of the respondents are unmarried.

LIKERT SCALE ANALYSIS

A Likert Scale analysis is a Method of measuring attitudes. Ordinal scale of response of a question or statement, ordered in hierarchical sequence from strongly negative to strongly positive, used mainly in behavioural science and psychiatry, In Likert's method, a person's attitude is measured by combining (additional or averaging) their responses across all items.

FORMULA

Likert scale =

$$\frac{\sum(Fx)}{\text{Total number of respondents}}$$

F = Number of Respondents
x = Likert Scale value
(FX) = Total Score

TABLE: 4

RESPONDENTS SATISFACTION WITH THE SERVICES OF LIC

S.N	Categories	No. of respondents	Likert scale	percentage
1	Highly Satisfied	14	4	56
2	Satisfied	42	3	126
3	Neutral	56	2	112
4	Dissatisfied	8	1	8
	total	120		302

$$\begin{aligned} \text{Likert Value} &= \frac{\sum fx}{\text{No. of Respondents}} \\ &= \frac{302}{120} \\ &= 2.5 \end{aligned}$$

INTERPRETATION

Likert scale value is 2.5 is greater than the mid value (2) so the respondents are satisfied with the service of the LIC.

FINDINGS, SUGGESTIONS AND CONCLUSION

- 43% of the respondents of the age of 21-30.
- 53% of the respondents are male.
- 73% of the respondents are married.
- 44% of the respondents are under the educational level upto under graduate.
- 44% of the respondents are earning the values of Rs. 25001-50000.
- 62% of the respondents are in nuclear family.

- 37.5% of the respondents are under the occupational status as private employees and agricultures.
- 38% of the respondents are having more than 3 dependents.
- 44% of the respondents are using the insurance policy for their investment purpose.
- 45% of the respondents prefer for their long term plan.
- 52% of the respondents are aware by agents.
- 48% of the respondents are preferring age group of 26-35 years.
- The respondents are satisfied with the penalty charged on the late payment of premium on LIC.
- The respondents are satisfied with the bonus and interest of the LIC.
- The respondents are satisfied with the pre and post paid services of the LIC.
- The respondents are satisfied with the services offered by the LIC.
- The respondents are satisfied with the riders' benefits of the LIC.

SUGGESTIONS

- The customer satisfaction should be the main focus of any service firm especially to the life insurance company. This will result in customer retention leading to improved profitability and growth of the life insurance companies.
- The life insurance company should ensure effective marketing information and communication facilities. The strategic planning should be adopted deliberately to identify and satisfy the customer's needs and wants.
- The Life Insurance Company should invest in advertising, conduct road shows, and spend money on hoardings, so that it can propagate better awareness better awareness about its various lesser known products.
- LIC should also tie up with several other banks apart from the existing ones to sell its products ie, through bancassurance.

CONCLUSION

The competitive climate in the life insurance market has changed over the last few years due to the regulations of IRDA (Insurance Regulatory and Development Authority) and the expectations of the policyholders are also changing. Insurance companies are targeting upon the policyholders by giving them returns with the mission to make them satisfied. The life insurance companies must take care to ensure that every



policyholder is totally satisfied as a result its customer base has grown significantly. While designing the marketing strategy, They have to frame the strategies in two aspects ie, to win over the hearts of the policyholders and to tackle the competition. This is possible only through the agents and employees in life insurance companies. A lot is to be done by the life insurance companies to maximize the satisfaction of the policyholders and improve the quality of service.

REFERENCE

1. **Rao C.R.**, “A Comparative Analysis on customer relationship management in public sector and private sector life insurance companies”, *Global research analysis (2014)*, 3(3), 85-87.
2. **Babita Y., & Anshuja T.**, “ A study on factors affecting customers investment towards life insurance policies”, *International journal of marketing. Financial services & management research (2012)*, 1(7), 106-123.
3. **Tiwari A., & Yadav B.**, “ A comparative analysis of investor’s Risk perception towards public & selected private life insurers in Jabalpur district of Madhya Pradesh”, *Gyan Jyoti E-journal (2013)*, 3(3), 11-22.



TERRITORIAL SPECIALIZATION AND LOCATION OF AGRICULTURAL PRODUCTION - ADAPTATION TO MARKET RELATIONS

Muminov Bakhodir Orifjonovich

Candidate of Economic Sciences, Head of the Department of Monitoring and Internal Control, Tashkent State Agrarian University, Tashkent, Uzbekistan

Bustonov Komiljon Kumakovich

Candidate of Economic Sciences, Associate Professor of the Department Agribusiness and Investment Activity, Tashkent State Agrarian University, Tashkent, Uzbekistan

Mardiev Nurali

Candidate of Economic Sciences, Associate Professor of the Department Agribusiness and Investment Activity, Tashkent State Agrarian University, Tashkent, Uzbekistan

Siddikov Zakhid Tulkunovich

Candidate of Economic Sciences, Associate Professor of the Department Agribusiness and Investment Activity, Tashkent State Agrarian University, Tashkent, Uzbekistan

Article DOI: <https://doi.org/10.36713/epra5620>

ABSTRACT

In accordance with market relations, scientific approaches to the regional specialization and rational placement of agricultural production have been made. The article analyzes the economic growth of the country through the assessment of the territorial specialization of the state and its constituent entities, the effective use of domestic opportunities and potential of the regions of the Republic of Uzbekistan on the basis of scientific approaches, adaptation to agricultural market mechanisms. In addition, appropriate recommendations were made based on the results of consistent work carried out on the basis of regional specialization of agricultural production and crop placement.

KEYWORDS: *agricultural production, regional specialization, rational placement of crop types and varieties, regional natural and economic conditions, cost-effective technology, economic efficiency, assessment of regional specialization, free market conditions, efficient distribution.*

INTRODUCTION

In the context of the gradual implementation of market reforms in our country, it is important to ensure sustainable economic growth and effective use of existing potential in regional and natural economic zones. Effective use of domestic opportunities and potential of the regions of the republic, adaptation of agricultural producers to market mechanisms depends in many respects on the economic growth of the state and

the entities that make up its territorial structure. It is important to ensure socio-economic development through the specialization and placement of agricultural production on the basis of full use of favorable regional factors and opportunities, taking into account the national interest, reducing the negative effects of certain natural and economic conditions.

The Government has identified the most important priorities for sustainable development of the agricultural economy and created the necessary conditions to



increase the volume and improve the quality of food products through the specialization of agricultural production and optimization of crop composition as a result of the development of strategic programs for their implementation serving.

Decree of the President of the Republic of Uzbekistan dated May 11, 2020 "On additional measures to specialize the regions of the Republic in the cultivation of agricultural products"

Presidential Decree No. 4709 provides for the diversification of agriculture, increasing the production of competitive products that meet the requirements of domestic and foreign markets by specializing the horticulture, viticulture, horticulture, potato and other food products in accordance with the soil and climatic conditions of the districts. In order to widely introduce scientific innovations and increase the material interest of producers, the regions of the republic should be gradually specialized in the cultivation of certain types of agricultural products [1].

In today's world of integration and globalization, ensuring food security requires a sustainable development of agriculture, adaptability to the changing external environment, a variety of innovations and the development of science and technology. The normative and legal acts adopted in recent years for the development of the agricultural sector in the country provide an opportunity to radically change the territorial specialization of agricultural production and the location of crops.

As a result of consistent work carried out on the basis of agricultural reform, optimization of land allotted to farms, regional specialization of agricultural production and crop placement, structural and qualitative changes are taking place in the agricultural sector of our economy. Along with strategically important agricultural crops such as cotton and grain, production in the fruit and vegetable, livestock, poultry and fisheries sectors also increased significantly.

One of the key issues of a market economy is the development of the territorial division of labor in the country, the formation of economic systems of economic regions and regions. At this point, it is not necessary for all regions to specialize in the cultivation of only one or mainly one type of product, it is important to develop several other sectors of the economy (horticulture, vegetable growing, animal husbandry and secondary production) along with the main production sector.

However, the difference between agriculture and industrial sectors is that specialization is characterized by its specificity in a broad sense. For example, such a feature of agriculture shows that the relationship of the production cycle with the life cycle of plants and animals has a significant impact on the possibility of specialization. Although there is a somewhat less impact on livestock, they are much larger in crop production and are manifested in the seasonality of agricultural

work during a single and full production period so that there is a sharp difference in the use of factors of production.

The subject of specialization is the separation of the production of the finished product or its limited range. In crop production it is the production of elite seeds, while in animal husbandry it is the production of pedigree young cattle, meat, eggs.

Elemental specialization consists of linking individual elements, types of parts, or different enterprises and aggregating them in the parent enterprise. "In agricultural production, it has only a place in the production of complete ration feed mixes and components in the production of compound feeds" [3].

Territorial specialization is the direction of production of a designated area, republic, region, administrative district, and so on.

Territorial specialization is the process of division of labor in agriculture at the national, regional, district and district levels, the development and timing of agricultural sectors, the culture of implementation in accordance with the level of development of material and technical base and increase the cost of production. allows for more efficient use of the natural and economic conditions of the regions [4].

A particular internal branch of the internal division of labor is called an internal network specialization. In this case, the absence of such a term on the activities of the enterprise is considered as a general network. Such specialization is practically described for all branches of agricultural production. This can be explained by the specialization of crop production in the production of cereals, potatoes, vegetables, fodder. In turn, this internal network leads to a division of labor in the production of certain crops or types of products.

In order to produce the same type of product in the specialization within the farms, several departments, farms and farmers of the same farm unite in work processes, between which there is a division of labor. For example, fattening farms, winemaking, canning, etc.

Intra-farm specialization reflects the specialization of enterprise production, leading to its consolidation. Such specialization shows the degree of centralization of production, ensuring the rapid development of farms. This type of specialization consists in the formation of multidisciplinary directions, taking advantage of the existing internal opportunities in the specialized farms operating in the country during the ongoing reforms.

The type of interdisciplinary specialization is characterized by greater specificity between fodder production, organic fertilizer preparation, use of means of production and labor, primary and secondary industries, crop and livestock [5]. As a result of such specialization, a number of interrelated productions occur on farms. Cotton production, for example, requires the use of unconditional crop rotation. Crop rotation, in turn, necessitates the development of



livestock sectors. As a result, material and labor resources are concentrated in one enterprise for the production of agricultural products.

The appearance of general economic specialization, the production of the main commodity product in this or that farm is determined by the production in the form of each enterprise.

General economic specialization represents the process of division of labor between individual enterprises, aimed at increasing the volume of production and reducing the cost of its production in some internal territorial subdivisions [6].

The essence of domestic specialization is agricultural production, taking into account their specific conditions for economic units in the rational placement of the industry and the production of certain types of products [7].

The specialization of production is the division of social labor in the broadest sense.

If the concept of "specialization" is clarified, it is understood the natural and economic conditions of enterprises in the regions of the country, the social division of labor in the process of placement of production of certain types of goods, taking into account the requirements of market laws.

The experience of the world economy shows that significant changes are taking place in regional specialization and placement. Most importantly, the world economic system is developing further. This is due to the globalization of the system, the improvement of the specialization and location of agricultural production between countries and regions, the intensification of economic integration processes.

It should be noted that in the past, agricultural countries specialized in the cultivation of certain products, but in the modern economy, the focus is on the production of various products, resulting in an uneven increase in the level of economic development of countries.

The specialization and placement of agricultural production is primarily explained by the availability of space, i.e. land area. However, the natural-geographical, economic-social, that is, the location of space plays an important role in the production of any type of agricultural product. In particular, if agricultural production is organized where it is desired, it will not lead to the intended economic benefits, leading to environmental problems, increased transportation and other costs. Therefore, in the scientifically correct placement of agricultural production sectors and crops, it is important to take into account not only regional but also sectoral characteristics.

It is known that natural and socio-economic factors have a direct impact on the specialization and location of agricultural sectors. In particular, in the process of the natural environment, first of all, the importance of climate, water and soil is great. Depending on them, the natural temperature, surface and groundwater, soil

characteristics determine the territorial specialization and location composition of agricultural production. For example, in the growth and maturation of a plant, the sum of the useful temperatures throughout the year forms the required vegetation period.

As a result of the integration of network specialization, markets of different scales will emerge. They will be local, regional, interregional, national and international. Markets within countries define the boundaries of existing economic regions, because the market at each stage has its own sphere of influence, space. Today, the sectors that specialize in the world economy are also called market-specific sectors.

The harmonization and stability of the national economy of each country is based on the gradual saturation of markets at different levels with their products, the creation of opportunities to replace imported products.

Under the conditions of market relations, the situation in agricultural production has also changed completely. In this context, the market itself determines the demand for the product as a key factor. The influence of other factors, directly or indirectly, is relatively weak. This is because the deepening of the process of specialization, the increase and decrease of production is determined by the market, not the state, and the state regulates this process by one means or another.

MATERIALS AND METHODS

In the context of liberalization of the economy, as in industry, market relations are emerging as a key factor in the placement of agricultural sectors. This is because the volume of agricultural production today is determined by the market, the price. This is due to the fact that in the current situation, due to the fluctuations in the market of agricultural products, the prices of some types of products (potatoes, carrots, onions, tomatoes, etc.) that are necessary for the daily needs of the population are much cheaper or more expensive. This, in turn, has an impact on the specialization and location of this type of product in exchange for changing market conditions.

The fact that the bulk of the products grown on farms today are not commodities, and in some cases used for domestic needs (personal consumption, seeds, processing, the amount given to workers, etc.) exceeds the volume of products sold, the instability of production, its natural Given that it depends in many respects on climatic conditions, as well as the priority given to the development of farms on a multi-sectoral basis, the approach put forward by most scientists, ie the share of branded products in GDP does not allow a clear and comprehensive assessment.

With this in mind, the following formula is proposed to assess the level of specialization in a particular farm example:

**For products grown for state needs:**

$$S_d = \frac{IP + (D_p - D_c)}{AP} * 100$$

Here:

S_d - level of specialization of the farm,%;

IP - the value of the product grown in the assessed industry, mln. Soums;

D_p - the value of the product at the disposal of the farm (at average market prices), million soums;

D_c - the value of the part of the product that remains at the disposal of the farm into a secondary commodity (a product that is valued in money for wages and other debts or prepayments and given to workers, suppliers and employees), million soums;

AP - the value of agricultural products grown in all sectors, mln. soums.

For products grown for the free market

$$S_l = \frac{IP}{AP} * 100$$

Here:

S_l - level of specialization of the farm,%;

IP - the value of the product grown in the industry under assessment, million soums;

AP - the value of agricultural products grown in all sectors, mln. soums.

When determining the level of economic specialization using this formula, if the estimated share of the industry is more than 50 percent, the enterprise is considered to specialize in the production of a single industry product.

If the sum of the shares of the two industries is more than 60 percent, and the share of each of them is not less than 25 percent, the enterprise is considered to specialize in the production of two types of products.

In enterprises specializing in the cultivation of three types of products, these figures should not exceed 75% and not less than 25%, respectively.

It is advisable to consider farms that do not meet any of the above criteria as diversified farms.

In the same way, it is proposed to assess the level of specialization of agriculture in the region (district), including:

For products grown for state needs

$$S_l = \frac{\sum IP + (\sum D_p - \sum D_c)}{\sum AP} * 100$$

Here:

S_l - level of specialization of the region,%;

IP - the sum of the value of the product grown in the industry, valued at the region, million soums;

D_p - the sum of the value of products (at average market prices) at the disposal of farms in the region, million soums;

D_c - the sum of the value of the part of the product remaining at the disposal of farms in the area, converted into secondary goods (products valued at money for wages and other debts or prepayments, given to workers, suppliers and employees), million soums;

AP - the sum of the value of agricultural products grown in all sectors of the region, million soums.

For products grown for the free market

$$S_l = \frac{\sum IP}{\sum AP} * 100$$

Here:

S_l - level of specialization of the farm,%;

IP - the value of the product grown in the industry under assessment, million soums;

AP - the value of agricultural products grown in all sectors, mln. soums.

RESULTS AND DISCUSSION

Raising the formation and development of farms to a qualitatively new level, on the one hand, focused on the restructuring of low-profit and loss-making farms and the placement and territorial specialization of crops, on the other hand, the formation of land, property and regional division of labor. (motivation) led to a radical change. As a result, the volume and quality of products grown by farms are improving from year to year, creating an opportunity to increase resource efficiency.

As a result of a comprehensive study of the above scientific views and approaches, taking into account the natural, climatic and economic conditions of the studied areas, the rational placement of industries on a scientific basis, the identification of potential and significant sectors and their priority through accurate assessment of specialization Suggestions were made to identify areas for development and improve the methodological framework for assessing the level of specialization of agricultural production based on current practice.

Putting this proposal into practice, the level of specialization (S_l) of the main types of agricultural production in Naryn district of Namangan region was methodologically assessed based on practical research.

At the same time, on the basis of methodological assessment of products grown for the needs of the state:



In cotton growing

$$SI = \frac{19129,7}{110212} * 100 = 17,3\%$$

In grain growing

$$SI = \frac{17880,1 + (4500 - 2700)}{110212} * 100 = 17,8\%$$

Based on the methodological assessment of products grown for the free market:

In vegetable growing

$$SI = \frac{43963,5}{110212} * 100 = 39,9\%$$

In the orchard

$$SI = \frac{9239,2}{110212} * 100 = 8,4\%$$

Using the above formula, the level of specialization of Naryn district was determined based on the analytical data [8]. Accordingly, the share of the assessed sector, ie the level of specialization of agricultural production is 17.3% in cotton, 17.8% in grain, 39.9% in horticulture and 8.4% in horticulture.

According to the results of our research, if the network production is more than 50%, to grow a single network product; to cultivate two types of products if the sum of the shares of the two industries is more than 60%; when the sum of the shares of the three industries is more than 75%, it is investigated that the three types specialize in the cultivation of the product.

The results of the analysis show that in the Naryn district selected for the study, there was no level of specialization in the production of agricultural products, namely, one, two or three types of agricultural products. This, in turn, is characterized by the fact that the regional specialization of the district is focused on the development of various sectors, forming a small network.

CONCLUSION

In the specialization of agricultural production and the rational placement of crops, it is important to determine the implementation of the following objectives, including:

- meet the requirements of effective distribution of available resources in a free market on the basis of maximum use of the features of agricultural production in the process of specialization;
- Ensuring the stability of the economy by increasing the income of specialized farms producing agricultural products in the placement of crops;
- organization of the correct placement of crops and high-yielding varieties in the production of products

that meet the requirements of foreign and domestic markets in accordance with the market economy;

- Taking into account the state of effective use of agro-technological measures of their care and cultivation in the placement of crops and varieties. Because in this process, each type of crop, as well as crop varieties have their own characteristics and have their own agro-technical rules.

- the development of cooperatives, which directly shape the integration of agricultural producers in the specialization and location of the industry. This is because cooperation plays an important role in the harmonious distribution of agricultural production, the integration of producers and service enterprises. Therefore, it is necessary to establish regional specialized cooperatives.

In general, in the specialization of agricultural production, it is important to take into account regional natural and economic conditions (soil, water, precipitation, resources, availability of infrastructure, population location, proximity to the city, etc.) in the placement of crops and varieties.

REFERENCES

1. *Resolution of the President of the Republic of Uzbekistan dated May 11, 2020 No PP-4709 "On additional measures to specialize the regions of the Republic in the cultivation of agricultural products" Tashkent 2020.*
2. Kosimov M., Kholmiraev I., Khamdamov. (2016). A. *Potential and reserves of fruit industry of Uzbekistan. Collection of theses of the International scientific-practical conference "Prevalence of fruit production of Uzbekistan", Tashkent: TashGAU, July 13, pp. 8-12.*
3. Kosimov M., Kholmiraev I., Khamdamov A. (2016). *Potential and reserves of the fruit and vegetable industry of Uzbekistan. Collection of abstracts of the International scientific-practical conference "Superiority of fruit and vegetable products of Uzbekistan", Tashkent: Tashkent State Agrarian University, July 13, 2016, 8-12 p.*
4. Ilyina. Z.M. (2002). *The effectiveness of specialization and cooperation in agriculture of the Republic of Belarus.* ed. Z.M. Ilyina, Minsk: BelNII Agrarnoy Ekonomiki, pp. 14-16.
5. Yakovlev B.I., Yakovlev V.B. (2005). *Organization of production and entrepreneurship in the agro-industrial complex.* Moscow: Kolos, pp. 74-75.
6. *Economy of organizations and branches of the agro-industrial complex.* In 2 books. Book. 2. under total. ed. acad. V.G. Gusakov. Minsk: Belarusskaya nauka, 2007, T. 1, 891 p. (pp. 41-43).
7. Gadzhimuratova K.B. (2009). *Specialization and concentration of agricultural production. Regional problems of economic transformation.* No. 1, pp. 87-95.
8. *Economy of organizations and branches of the agro-industrial complex.* Institute of Modern Management Technologies. 2014, p. 41.
9. *Statistics of Naryn district of Namangan region, 2019.*



PHOTOSYNTHETIC PRODUCTIVITY OF CHERRY AND SWEET CHERRY LEAVES DUE TO ROOTSTOCK AND ARTIFICIAL FORMS OF TREE CROWNS IN THE GARDEN

Khalmirzaev Dilmurod Kamilovich

PhD, Associate Professor of the Department Fruit Growing and Viticulture, Tashkent State Agrarian University, Tashkent, Uzbekistan

Yenileyev Najdat Shavkatovich

Candidate of Agricultural Sciences, Associate Professor of the Department Fruit Growing and Viticulture, Tashkent State Agrarian University, Tashkent, Uzbekistan

Abdikayumov Zaynilabiddin Abduvokhidovich

PhD, Associate Professor of the Department Fruit Growing and Viticulture, Tashkent State Agrarian University, Tashkent, Uzbekistan

Article DOI: <https://doi.org/10.36713/epra5623>

ABSTRACT

In the scientific article presents the results of research on the study of varietal cherries and artificial ways of formation of the trees to the level of photosynthetic activity of leaves with the orientation of growing trees, their intensive technology. In the research, the varieties of cherries Shubinka, Podbelskaya and Shpanka Chernaya (black) zoned in the Republic, as well as sweet cherries Volovye serdtce, Revershon and Bahor, grown on a low-growing vegetatively propagated rootstock VVA-1 and VSL-2 (Krymsky-5) were used as the object of research. As a result of the conducted research, it was found that the optimal crown system for cherry and sweet cherry varieties is the five-skeletal wall. Crown formation in these forms helps to reduce the volume of the crown to an average of 25%, at which the net productivity of leaf photosynthesis in comparison with the usual crown formation – free-growing and sparse-tiered reaches a value of 34.73 grams/m² per day. When forming bushy forms of the crown of cherries and sweet cherries, the level of leafiness of leaves improves and the content of chlorophyll in them increases to 13.42 mg/g of raw leaf mass.

KEYWORDS: *cherry, sweet cherry, density, variety, leaf, area, crown, forming, photosynthesis, productivity, pruning, index, projection.*

INTRODUCTION

Currently, the main method of growing cherries and sweet cherries in Uzbekistan is grafting on seed rootstocks. When such plants are planted in the garden, strong-growing plants are formed. Planting material is put according to the scheme of 5×4 and 6×5 meters. With such planting schemes, the density of trees in the

garden is 500 and 334 pcs/ha, respectively, and the gross productivity does not exceed 60-90 c/ha [2, 3].

The disadvantages of this method of placement include the irrational use of the food area, the late entry of plantings into the time of commercial fruiting, low yield, inconvenience in caring for plants due to the large size of the crowns, and others [1].



Increasing the density of plantings can significantly improve the efficiency of land use, as well as material and labor resources. The trend towards increasing plant density is becoming more common, especially in countries with high land values. Often in the specialized literature, the definition of an intensive garden is understood as synonymous with a garden with a high density of trees on clonal rootstocks. But this definition largely characterizes only the potential intensity of the garden, and not the actual one [6, 7].

A significant increase in the productivity of the breed is unthinkable without the development of new ways of growing crops. In particular, growing plants on low-growing vegetative propagated rootstocks is accompanied by the development of new crown formation systems for them [4].

The practical implementation of these main aspects of the technology allows plants in the garden to be placed more thickly, bringing the planting density to 1000-2500 pcs/ha. The latter allows increasing the productivity of plants up to 100-150 or more centners per unit area of the garden.

Cherry and sweet cherry trees grown on low-growing vegetative propagated rootstocks, having less development of the aboveground part, have better illumination of the crown; form a well-developed leaf apparatus that effectively uses solar energy to accumulate plastic substances for the formation of generative formations and crops.

MATERIALS AND METHODS

The study was conducted in 2016-2019 at the information and consultation center (Extension center) at the Tashkent state agrarian University. The area of the experimental plot is 0.25 ha. The scheme of planting of trees is 4×4 meters.

As an object of research, the varieties of cherry Podbelskaya, Shubinka and Shpanka Chernaya (black), varieties of sweet cherry Volovye serdtce, Revershon and Bahor zoned in the Republic were used. As a rootstock for cherries, vegetatively propagated VVA-1 was used, and for sweet cherries-VSL-2.

The formation of the cherry crown was carried out according to the "fruit wall" type, with the formation of a crown with three and five skeletal branches and their departure along the row, for sweet cherries-a simple bowl, a KGB (Kim green Bush), an Austrian Bush and a V-shaped one. The Central conductor above these

branches was cut out. The left branches were subordinated in height, the thickening ones were cut out.

When forming a small-sized flat crown in the crown of trees, two well-developed skeletal branches were selected, directed along the row and horizontally fixed to wooden stakes during the first two years of growing plants. All other branches were deleted. In the spring of the following year, all vertical branches formed on the two main horizontal branches were limited in length by 60-70 cm. During the study period, particularly the development of aboveground parts of trees of cherries and sweet cherries was accompanied by the following physiological tests: the definition of net productivity of photosynthesis of leaves and leaf area of individual trees on a unit area of a garden [5].

RESULTS AND DISCUSSION

The development of trees in the garden, their early fruitfulness, and stable fruiting over the years of operation in ontogenesis significantly depends on the effective activity of the assimilation apparatus of plants.

The research showed that over the years of experiments, the productivity of leaf photosynthesis in the experimental variants mostly depended on the varietal characteristics of cherries.

Of the tested cherry varieties, with all methods of crown formation, the higher net productivity of leaf photosynthesis was observed in the Shpanka Chernaya (black) variety 34.63-35.33 g/m² per day. Low productivity of photosynthesis during the growing season was characterized by the cherry variety Shubinka 20.81-26.17 g/m² per day. The Podbelskaya variety had an intermediate position in this physical indicator. In our opinion, the high characteristic of the Shpanka Chernaya (black) cherry variety in terms of photosynthetic productivity in comparison with other cherry varieties is explained by the morphological structure of the aboveground part – the shortness and large size of the leaf plates.

Of the studied crown forms, the best physiological indicators of photosynthetic activity of leaves in the cherry variety Shpanka Chernaya (black) were noted in the flat and sparse-tiered crown variants, in the Podbelskaya variety the three-skeletal and five – skeletal wall variants, Shubinka-five-skeletal wall and sparse-tiered (table 1).

**Table 1****Influence of the cherry crown formation system on the net productivity of leaf photosynthesis, g/m² per day (2016-2019)**

Variety	Crown form			
	flat	Fruit wall		Sparse-tiered - cont.
		three-skeletal	five - skeletal	
Shubinka - cont.	20,81	25,73	26,01	24,17
Podbelskaya	29,87	32,49	34,73	20,15
Shpanka Chernaya (black)	34,63	33,72	32,47	32,15
LSD ₀₅	2,73	1,05	1,12	2,37

Among the studied sweet cherry varieties and artificial crown formations, the highest photosynthetic activity of leaves in the experiment was shown in the varieties Volovye serdtce and Bahor, which varied in the range of 23.49-42.65 g/m². Of the tested artificial crown forms, the best results of net leaf productivity were observed in the experiment when using a V-shaped crown shape. According to the studied cherry varieties, the value of this physiological indicator of the accumulation of plastic substances in the leaves of sweet cherry varieties was 35.33-42.65 g/m² of leaves. Also, high indicators of this factor were observed when using the KGB crown form, where the value of net leaf productivity was 34.55-41.71 g/m² of leaf area. When using the crown formation of sweet cherry trees in the form of an Austrian Bush, the net productivity of

photosynthesis in comparison with KGB forms and the V-shaped value of photosynthesis was lower than 5-10%. The high photosynthetic activity of the leaves of the studied cherry varieties with the above artificial crown forms is explained by the small volumes of the tree crown and the high throughput of sunlight into the inner aboveground part of the plants (Table 2).

Along with the varietal characteristics of cherries, the photosynthetic activity of the leaves is naturally influenced by the number of leaves per individual tree and the area of leaf plates.

In our experience, the largest average size of leaf plates was the cherry variety Shpanka Chernaya (black) – up to 25.7 m²/tree, the smaller 25.9 m²/tree variety Podbelskaya and the smallest size of the variety Shubinka-14.4 m²/tree.

Table 2**Influence of the sweet cherry crown formation system on the net productivity of leaf photosynthesis, g/m² per day (2016-2019)**

Crown forms	Varieties		
	Revershon	Volovye serdtce	Bahor
Simple bowl – cont.	20,42	24,60	23,49
KGB	34,55	41,71	39,73
Austrian Bush	30,40	36,70	34,96
V-shaped	35,33	42,65	40,62
LSD ₀₅	3,4	1,0	0,7

Of the studied crown forms for growing the breed using intensive technology, the optimal one for the cherry variety Shpanka Chernaya (black) is a five-skeleton fruit wall, in which the area of leaves formed on a separate tree was 29.2 m², respectively. For the Podbelskaya variety, such conditions were created when forming a crown of the three- and five-skeletal wall type

- 27.0 and 29.2 m²/tree, and the Shubinka flat – shaped crown and five-skeletal wall varieties-13.3 and 15.7 m²/tree (Table 3).

The trend of better photosynthetic activity of leaves in trees with a sparser crown shape is also explained by the experimental data shown in table 4.

**Table 3****Influence of the cherry crown formation system on the leaf surface area of trees, m²/tree (2016-2019)**

Variety	Crown forms				
	Flat	Fruit wall			Sparse-tiered - cont.
		three-skeletal	five - skeletal	Free-growing	
Shubinka	16,5	13,3	15,7	12,9	13,6
Podbelskaya	24,3	27,0	29,2	24,5	24,7
Shpanka Chernaya (black)	26,4	26,1	27,3	20,4	23,6
LSD ₀₅	1,3	0,7	1,5	2,5	3,3

Table 4**Influence of the cherry crown formation system on the leaf surface area of trees, m²/tree (2016-2019)**

Crown forms	Varieties		
	Revershon	Volovye serdtce	Bahor
Simple bowl - cont.	18,53	23,49	21,36
KGB	21,39	23,92	22,40
Austrian Bush	20,38	24,74	23,57
V-shaped	22,45	21,69	21,09
LSD ₀₅	0,7	0,4	0,2

The data from this table show that in those variants of the experiment, where the trees had a high accumulation of plastic substances, the size of the leaf plates was higher than in the control version of the crown formation of the "simple bowl" type. So, if in this version of the experiment for the studied sweet cherry varieties, the size of the leaf area varied within 18.53-21.36 m²/tree, then with other experimental artificial ones it was 20.38-24.74 m²/tree, it means, it increased by 15.8%.

The best conditions for the formation of more developed leaf plates were noted when using such cherry varieties as Volovye serdtce and Bahor with the formation of the KGB and V-shaped crown. In these variants of the experiment, the area of leaves per individual tree to the control variant increased by 21.1%.

Along with the formation of leaves on cherry trees, a significant role is played by chlorophyll cells contained in chloroplasts, which determine the efficiency of using solar energy by leaves for the formation of spare plastic substances.

In our studies, the content of chlorophyll in the leaves of the cherry varieties used was approximately the same and ranged from 12.13-12.85 mg/g of raw material. Due to the use of various artificial forms of tree crowns, a certain increase in their content in chloroplasts was observed in the cherry variety Shpanka Chernaya (black) in variants with three- and five-skeletal branches of the crown of 13.42 and 13.25 mg/g of raw matter. We believe that this method of crown formation is most acceptable for intensive cherry gardening (Table 5).

A study on determining the content of chlorophyll in sweet cherry leaves in connection with varietal characteristics and artificial forms of the crown of trees in the garden, showed that the shape of the crown in a certain way affect the content of chlorophyll cells in chloroplasts. The quantitative presence of these organelles has a stimulating effect on the processes of photosynthesis in leaves, plant growth and development.

Table 5**Influence of cherry crown formation types on chlorophyll content in leaves "a" and "c", mg/g of raw mass (2016-2019)**

Variety	Crown forms				
	Flat	Fruit wall			Sparse-tiered - cont.
		three-skeletal	five - skeletal	Free-growing	
Shubinka	12,13	11,39	12,03	11,63	12,71
Podbelskaya	12,44	11,99	11,17	11,01	9,82
Shpanka Chernaya (black)	12,85	13,42	13,25	12,32	13,13
LSD ₀₅	0,24	0,41	0,63	0,32	0,70

**Table 6****Influence of types of sweet cherry crown formation on the content of chlorophyll in leaves "a" and "c", mg/g of raw mass (2016-2019)**

Crown forms	Varieties		
	Revershon	Volovye serdtce	Bahor
Simple bowl – cont.	12,86	14,17	13,50
KGB	14,12	15,56	14,82
Austrian Bush	13,72	15,12	14,40
V-shaped	15,73	17,33	16,51
LSD ₀₅	0,8	0,2	0,3

Our study revealed certain differences in the content of chlorophyll in the context of experimental variants. Experiments have shown that in all varieties of sweet cherries, the formation of artificial crown shapes caused an increase in the content of chlorophyll cells "a" and "c" in chloroplasts from 12.86 to 17.33 mg/g of the raw substance of the leaf mass. In particular, in the Revershon sweet cherry variety, when forming the crown according to the KGB and Austrian Bush types, the content of both types of chlorophyll in the leaves was 13.72-14.12 mg/g, Bahor 14.40-14.82 and Volovye serdtce 15.12-15.56 mg/g per raw mass of leaves, respectively. The maximum level of chlorophyll content in the leaves of the studied sweet cherry varieties was detected at the V-shaped formation of the crown of sweet cherry trees of 1.73-17.33 mg/g of raw leaf mass (Table 6).

growing. *Bulletin of the Russian Academy of agricultural Sciences. No. 1, pp. 50-53.*

5. *Dospekhov B.A. (1979). Methods of experimental work. - Moscow: Kolos, 415 p.*
6. *Kostyuk L.A. (2006). Theoretical and methodological foundations of economic and energy assessment of intensive technologies in horticulture. Fruit growing: scientific Tr.; Part 2, Volume 18. Samokhvalovich, 263 p.*
7. *Kudryavets R.P. (1990). Industrial technologies of cultivation of stone crops in the non - Chernozem zone. Moscow: Agropromizdat, 80 p.*

CONCLUSION

From the studied artificial forms of the crown, the best conditions for the photosynthesis process are provided in the cherry variety flat wall, sweet cherries - in the forms of the crown of KGB trees and the Austrian Bush.

When growing cherry varieties using intensive technology in three- and five- planar skeletal forms, sweet cherries in the form of KGB and Austrian Bush, the leaf surface area of an individual tree reaches 27.3-29.2 m², 24.74 and 29.2 m²/tree, respectively, which is 27.2% more than in the Republic of sparse-tiered crown formation.

When cherry trees form crowns in the form of a fruit wall, and sweet cherries of the KGB type and the Austrian Bush in leaf chloroplasts, the content of chlorophyll "a" and "c" reaches 13.42-17.33 mg/g of raw leaf mass.

REFERENCES

1. *Abrorov Sh. (2018). Modern intensive sweet cherry gardens. Tashkent: Baktaria press.*
2. *Agafanov N.V. (1983). Scientific bases of placement and formation of fruit trees. -Moscow: Kolos, 173 p.*
3. *Vekhov Yu.K., Kolesnikov A.F. (1998). New promising forms of clonal rootstocks for cherry trees. - Orel, VNIISPK, pp. 23-25.*
4. *Vekhov Yu.K., Kolesnikov A.F. (2005). Selection of clonal cherry rootstocks for the middle zone of fruit*



ASEAN'S CENTRALITY IN THE INDO-PACIFIC AND THE SOUTH CHINA SEA DISPUTE

Sushri Sangita Barik¹

¹PG Scholar – Political Science, Department of Politics and International Studies, Pondicherry University

Ayadoure S Stalin²

²PG Scholar – International Studies, Department of Politics and International Studies, Pondicherry University

Article DOI: <https://doi.org/10.36713/epra5633>

ABSTRACT

The South China Sea is the contested region between several ASEAN member nations and China. The rise of China along with its offensive Realpolitik policy has offended the sovereignty of many territorial nations in the South China Sea. In this article, the researchers would schematically analyze through the documentary analysis on the ASEAN's Centrality. Based on the epistemological and ontological inference, the researchers would argue that the ASEAN's centrality is based on the neo-liberal dilemma of reciprocity and thus neglecting the Statism in the South China Sea.

KEYWORDS: ASEAN, China, Indo-Pacific, Reciprocity, and the South China Sea Dispute.

INTRODUCTION

The emergence of China as the largest economy posits it to be the USA's systemic rival in the Indo-Pacific. China's assertive and unilateral policy of claiming legitimacy by declaring the South China Sea as its undisputable sovereign area by propounding the *Nine-Dash Line* that led to unrest among many littoral island countries. The result of this course was the challenge to 'Freedom of Navigation' in this region which in turn affected the major maritime powers interest like the US, Japan, etc. India as an emerging superpower viewed by the USA as a balancing state to China, the latter is continuously asserting its claim by citing the historical reason, flexing its muscles by initiating many unilateral measures like constructing artificial islands and military drills, for instance, the Spratly Island Case. However, the ASEAN Nations who are the vital actors in this dispute, in their 2019 July communique titled *ASEAN Outlook on the Indo-Pacific*, believes that the multilateral engagement with China and the USA is the inclusive option to diffuse the tension in the Indo-Pacific in general and the South China Sea Dispute in particular also

underscored that such engagements are the means to enhance trust in the region which will eventually create Win-Win situation (ASEAN, 2019). In this context, this article intends to analyze the ASEAN's centrality in the Indo-Pacific Region and their dilemmas on the South China Sea dispute. This paper hypothesizes that ASEAN's centrality is based on ASEAN's expectation that China would reciprocate thus reduces conflict region.

The South China Sea is highly strategic relevant due to the convergence of the resources that favours the blue economy, energy security, food security, etc. China with vast huge land and populations needs more resources to feeds its people and they view the South China Sea being a less exploited region as a potential destination. Also, China views the South China Sea's geographical proximity to Malacca Strait, Sunda Strait, Lombok Strait, and Luzon Strait as ideal statecraft for its Two Ocean Strategy. In that note to explicate the maritime superhighway relevance of these straits in the South China Sea, Zenel Garcia in her book titled *China's Military Modernization, Japan's Normalization, and the South China Sea*



Territorial Disputes commented that the South China Sea is one of the main arteries for global shipping, 50% of the world's merchant fleet tonnage crosses through the Malacca, Sunda, and Lombok Straits, with the majority continuing into the South China Sea (Garcia, 2019). A critical study moots the following question to critically examine why do the ASEAN expecting reciprocity from the South China Sea?

ASEAN'S CENTRALITY: CRITICAL EXAMINATION

The USA views China as a Systemic rival and on the rationality of its Indo-Pacific Policy that the systematic development of China's military capability will endanger the USA's military capabilities in the East Asian Region and eventually lead to denial of the USA's access in the Western Pacific (Cáceres, 2014). The USA also considers that China is a parochial power that is now intimidating several nations in the Indo-Pacific Nation to encroach territory. Despite considering China as a parochial power, the USA, in *Free and Open Indo-Pacific Charter*, underscored the narrative that it excludes no nation or intends the Indo-Pacific Nations to choose either one country as well, rather what it professes are the following four tenets, that are: Firstly, respect for Sovereignty and independence of all nations; Secondly, peaceful resolution of the disputes; Thirdly, free fair, and reciprocal trade based on open investment, transparent agreements, and connectivity; and Fourthly, adherence to international law, including freedom of navigation and overflight (U.S. Department of the State, 2019). It is very clearly absolved that the USA keeping its Indo-Pacific Strategy vision and it is not particularly targeted against any nation per se China but the contradiction is how China became a systemic contender to the USA?

The USA's basic tenets in the Indo-Pacific are viewed by China as they are directed against it like: the 'respect for Sovereignty' as envisaged in the charter has been presumed by China that it implicates China's aggression in the South China Sea. This presumption followed by China's aggressive patrolling in the South China Sea and counterclaiming the rights of passage viewed by the USA that China is not adhering to the international laws like the UNCLOS. What is the key point of difference between the USA and China's view on Indo-Pacific is: USA views the ASEAN as one regional entity but China does not view the ASEAN as one entity rather prefers each country's perspective than one common code. This, China's differing view had prolonged the efforts to attain the South China Sea's Common Code of Conduct. A sizeable number of scholars advocates that ASEAN's centrality is primarily due to the principle of reciprocity, ASEAN is advocating the Institutional

idea of Keohane by why proffering centrality. ASEAN's Centrality had negated explicitly the case of the zero-sum game to rule out the case of prisoner's dilemma to China.

Expecting reciprocity from China for co-operation, the ASEAN nations have explicitly asserted their rational egoism by making other Indo-Pacific stakeholders acceding the ASEAN's Centrality in the Indo-Pacific thus complicating the chances of China's demand for an individual-based common code. In this pursuit, ASEAN's victory in the multilateral arbitration again posits the rational egoism that they will cause the advocacy for a rules-based Indo-Pacific which would limit the cause of the USA and the other regional Indo-Pacific nations in the South China Sea. The tangible inference is that ASEAN's reciprocal and rational egoism would cause China to assert its neo-realist policy to cause status-revision in the South China Sea and would seek bandwagoning in the pursuit of China's interest. In other words, ASEAN's centrality and zero-sum game and the USA's departure from the Trans-Pacific Co-operation have been the catalyst to the process of China's dominance in the Indo-Pacific.

CONCLUDING OBSERVATION

Nevertheless, multilateral engagement is mandatory in a multi-folded dispute like the South China Sea and it is imperative to have all track level dialogues to diffuse the fevers at the South China Sea. At the same time, the multilateral engagements shall not be '*China minus*' and the ASEAN's centrality in the Indo-Pacific explicates the imperative of the common code in the South China Sea. The recent US Presidential election and the victory of His Excellency Joe Biden will cause the ex-post-facto dated 2016. In that direction, recently ASEAN Nations had strongly condemned the Chinese aggression in the South China Sea during the pandemic crisis and emphasized that China is bound by UNCLOS too. The ASEAN's Communique had underscored the importance of their priorities that is cooperation in maritime, connectivity, sustainable development, and economic integration. This communique indicates that ASEAN has corrected its 'ASEAN Way' of expecting reciprocity for co-operation

BIBLIOGRAPHY

1. ASEAN. (2019, June 23). *ASEAN Outlook on the Indo-Pacific*. Retrieved from ASEAN: <https://asean.org/asean-outlook-indo-pacific/>
2. Cáceres, S. B. (2014). *China's Strategic Interests in the South China Sea: Power and resources*. New York, USA: Routledge.
3. Garcia, Z. (2019). *China's military modernization, Japan's normalization, and the*



- south china sea territorial dispute. New York: Palgrave Macmillan.*
4. Keohane, R. O., & Martin, L. L. (1995). *The Promise of Institutional Theory. International Security*, 39-51.
 5. ORF. (2020, March 6). *Act east to act Indo-Pacific: India's expanding neighbourhood. Retrieved from Observer Research Foundation: <https://www.orfonline.org/research/act-east-to-act-indo-pacific-indias-expanding-neighbourhood-61985/>*
 6. Suzuki, S. (2010). *The myth and reality of China's 'soft power'. In I. Parmar, & M. Cox (Eds.), Soft Power and US Foreign Policy: Theoretical, Historical and Contemporary Perspectives (Routledge Studies in US Foreign Policy) (pp. 199-214). London: Routledge.*
 7. Thakkar, M. (2020, February 20). *South China Sea of brewing troubles and its implications for India. Retrieved from Modern Diplomacy: <https://moderndiplomacy.eu/2020/02/18/south-china-sea-of-brewing-troubles-and-its-implications-for-india/>*
 8. *The Economic Times*. (2019, June 1). *Act East to act Indo-Pacific: Agenda for the new government. Retrieved from The Economic Times: <https://economictimes.indiatimes.com/news/defence/act-east-to-act-indo-pacific-agenda-for-the-new-government/articleshow/69591279.cms?from=mdr>*
 9. *U.S. Department of the State*. (2019, November 4). *A Free and Open Indo-Pacific: Advancing a Shared Vision. U.S. Department of the State. Retrieved from <https://www.state.gov/wp-content/uploads/2019/11/Free-and-Open-Indo-Pacific-4Nov2019.pdf>*
 10. Yao, Y. (2015). *Diplomacy, China's Approach to Economics. In G. J. Ikenberry, W. Jisi, & Z. Feng (Eds.), America, China, and the Struggle for World Order: Ideas, Traditions, Historical Legacies, and Global Visions (pp. 161-188). Palgrave Macmillan US: Palgrave Macmillan US.*



A STUDY ON INVESTMENT PATTERN TOWARDS SALARIED EMPLOYEES IN COIMBATORE CITY

Mr. P. Kanagaraj

*Assistant Professor, Department of Commerce with Professional Accounting
Dr. N.G.P Arts and Science College, Coimbatore*

Pavithra. S

*Student of III B.Com (PA), Department of commerce with Professional
Accounting Dr. N.G.P Arts and Science College, Coimbatore*

ABSTRACT

Investment is the sacrifice of certain present value for the uncertain future reward. Generally, risk and return go together, if the investment has high risk simultaneously there should be a risk return. The objective of the study is to analyse the awareness level of salaried class investors towards the nature of investment, identify the time origin which they make their investment. The sample size which is taken for the study is 120. The statistical tool used for the study is simple Percentage analysis and Ranking analysis. The study is based upon primary data, so any wrong information given by the respondents may mislead the findings. In finance, the benefit from investment is called a return. The return may consist of capital gain or investment income, including dividends, interest, rental income etc. the projected economic return is the appropriately discounted value of the future returns. From the results of the study, it can be concluded that employees have shown that they are following good investment policies and they are satisfied with their investment practices. The findings of the study indicate that employee's perception has led to the investment appreciation exhibited through various factors.

KEYWORDS: *investment avenues, risk and return, liquidity, salaried employees.*

INTRODUCTION

Investment means the purchase by an individual of a financial or real asset that produce returns, proportionate to the risk assumed over some future investment period. For achieving this, one has to decide on how and where to deploy the savings, so that the future requirements for money can be best met.

The portion of investments that get segregated to various financial and investment policies of the salaried middle class of Coimbatore on whom this study is made, are due to several reasons like enjoying the benefits of the best investment schemes, tax exemption, foresight of their/ their children's future, emergency medical needs of the family and security reasons for risk coverage.

STATEMENT OF THE PROBLEM

Salaried people often fallaciously believe that they do not need any financial planning as their income and expenses are regular. In the areas of investment pattern of investors and individuals in various financial and physical investment avenues like bank deposits, real estate, and assets like gold and silver, it becomes all the more important to study and analyse by adopting advanced research in the preferences and level of investment towards various investment avenues available to the salaried employees.

SCOPE OF THE STUDY

The study survey was conducted with the help of a well-structured questionnaire consisting of relevant questions. The focus was on understanding the preference of investors with regard to investment avenues, their educational qualifications and



investment awareness level. The responses help in analysing the profile and investing habits of the investor and factors influencing the investor. This study will help the salaried class employees to plan investment towards maximizing the returns.

OBJECTIVES OF THE STUDY

1. To analyses the awareness level of salaried class investors towards the nature of investment.
2. To identify the time origin which they make their investment.
3. To analyses the factors influencing the investor in choosing the type of investments.

RESEARCH METHODOLOGY

➤ SAMPLE SIZE

The sample size which was taken for the study was 120.

➤ TOOLS USED FOR ANALYSIS

- Simple Percentage analysis
- Ranking analysis

REVIEW OF LITERATURE

Geethu Gopi, D. Priyanka And R. Preetha (2018)¹ in their study “Investment is an activity confined to specific financial aims of investors”. This study attempts to understand the investment preference of salaried employees in Ernakulam district. convenient random sampling method is used for selecting the sample. The author collected information was analysed by using different

statistical tools like T test, chi square analysis, correlation analysis and percentage analysis. The result of the study suggested most of the employee’s investment are directed to their personal expenses.

Dr. V. Krishna Kumari (2018)², “Impact of savings and investment behaviour of working in Chennai city”. It was said that the financial services sector has become highly diversified offering the women investors with a wide range of investment avenues. The author collected the primary data by administering a detailed questionnaire and also conducted depth personal interviews. The percentage analysis revealed that the maximum 63% of employees are investing for future benefits.

Bindu. T (2017)³, in his research paper titled savings and investment pattern of salaried employees in Palakkad district. The study was designed by descriptive and analytical one. A sample of 40 employees were collected through convenient sampling. There is no significant difference in the investment habit of employees based on gender.

ANALYSIS AND INTERPRETATION

The data collected from the samples have systematically applied and presented in tables under various headings in the following pages. They were also arranged in such a way that; a detailed analysis can be made so as to present suitable interpretations for the same. The data have been analyses by using the following statistical tools.

- Simple Percentage analysis
- Ranking analysis

SIMPLE PERCENTAGE ANALYSIS

TABLE SHOWING THE PURPOSE OF INVESTMENT OF THE RESPONDENTS

S.NO	PURPOSE OF INVESTMENT	NO. OF. RESPONDENTS	PERCENTAGE
1	Wealth creation	10	8
2	Tax savings	28	23
3	Earnings	32	27
4	Future expense	50	42
	TOTAL	120	100

(Source: Primary data)

INTERPRETATION

The above table shows that 8% of the respondents are wealth creation and 23% of the respondents are tax savings and 27% of the

respondents are earnings and 42% of the respondents are future expense.

Majority 42% of the respondents are investing for their future expenses

**TABLE SHOWING THE INVESTED THEIR SAVINGS OF THE RESPONDENTS**

S.NO	INVESTED THEIR SAVINGS	NO. OF. RESPONDENTS	PERCENTAGE
1	Fixed deposit	68	57
2	Gold/silver	28	23
3	Stocks	12	10
4	Real estate	12	10
	TOTAL	120	100

(Source: Primary data)

INTERPRETATION

The above table shows that 57% of the respondents are fixed deposit and 23% of the respondents are gold/silver and 10% of the

respondents are stocks and 10% of the respondents are real estate.

Majority 57% of the respondents are investing their savings in fixed deposit.

TABLE SHOWING THE INVESTMENT DECISION MAKER OF THE RESPONDENTS

S.NO	DECISION MAKER	NO.OF. RESPONDENTS	PERCENTAGE
1	Own	61	51
2	Spouse	20	16
3	Friends & relatives	32	27
4	Financial advisor	7	6
	TOTAL	120	100

(Source: Primary data)

INTERPRETATION

The above table shows that 51% of the respondents are Own and 16% of the respondents are spouse and 27% of the respondents are friends&

relatives and 6% of the respondents are financial advisor.

Majority 51% of the respondents are Own decision maker

**RANK ANALYSIS****RANK ANALYSIS OF BEST INVESTMENT INSTRUMENT**

S.NO	TYPES	RANK I	RANK II	RANK III	RANK IV	RANK V	RANK VI	TOTAL SCORE	RANK
1	SAVING BANK	21(6)	22(5)	14(4)	20(3)	22(2)	21(1)	417	5
2	FIXED DEPOSIT	14(6)	29(5)	22(4)	23(3)	20(2)	12(1)	438	4
3	GOLD/SILVER	22(6)	15(5)	20(4)	40(3)	12(2)	11(1)	442	3
4	POSTAL SAVINGS	24(6)	10(5)	19(4)	20(3)	30(2)	17(1)	407	6
5	REAL ESTATE	33(6)	20(5)	22(4)	19(3)	15(2)	11(1)	484	1
6	INSURANCE	27(6)	22(5)	30(4)	14(3)	12(2)	15(1)	473	2

*(Source: Primary data)***INTERPRETATION**

The above table shows that out of 120 respondents, saving bank is in the rank 5, fixed deposit is in the rank 4, gold/silver is in the rank 3, postal savings is in the rank 6, real estate is in the 1, insurance is in the rank 2.

INFERENCE

If resulted that real estate is in the 1 and it is influencing the respondents prefer real estate.

FINDINGS**SIMPLE PERCENTAGE ANALYSIS**

- Majority 76% of the respondents are coming under the category of private employee.
- Majority 42% of the respondents are investing for their future expenses.
- Majority 57% of the respondents are investing their savings in fixed deposit.
- Majority 51% of the respondents are own decision maker. Majority 60% of the respondents monitor their investment monthly.
- Majority 39% of the respondents had invested their income from sources of house property.
- Majority 51% of the respondents had awareness of investment schemes through digital media.
- Majority 48% of the respondents are given priority of investment under growth.

RANK ANALYSIS

- If resulted that real estate is in rank 1 and it is influencing the respondents to prefer real estate.

SUGGESTIONS

- Investment risk can be minimized which will in turn increase the investment by aged employees.
- Employees can invest in both short term and long-term securities which will enhance the return of their portfolio.
- The company can provide more advice to employees which will help to take better investment decision.
- Employees can consider other factors such as profitability, growth rate etc before structuring their portfolio.
- Employees can spread their investments across different sectors so as to maximize their returns.

CONCLUSION

From the results of the study, it can be concluded that employees have shown that they are following good investment policies and they are satisfied with their investment practices. The findings of the study indicate that employee's perception has led to the investment appreciation exhibited through various factors. A similar kind of investor group perception will enhance investment effectiveness. Employees not only contribute to their respective organization by their labour contributions, they do contribute to the development of national economy by investing in various investment avenues. This will further improve on economy in general and give more



revenues by way yield to the employee investors in particular.

REFERENCE

1. *GEETHA GOPI, D. PRIYANKA AND R. PREETHA- An insight into the savings and investment pattern of salaried employees working in private sector of shipping industries at Ernakulam, international journal of pure and applied mathematics,2018.*
2. *DR. V. KRISHNA KUMARI- Impact of Savings and Investment Behaviour of Working Women in Chennai City, open access 2018.*
3. *BINDU. T- savings and investment pattern of salaried employees in Palakkad district, www.icmrr.org , 2017.*

WEBSITES

1. www.indianjournals.com
2. shodhganga.inflibnet.ac.in
3. info.dogpile.com
4. www.iosrjournals.org



Mineral Composition and Antioxidant Profile of Jackfruit (*Artocarpus heterophyllus* Lam.) Seed Flour

Sylvia Borgis¹

¹PhD Scholar, Department of Food Science and Nutrition, College of Community Science, University of Agricultural Sciences, Dharwad- 580 005, Karnataka, India

Pushpa Bharati²

²Professor, Department of Food Science and Nutrition, College of Community Science, University of Agricultural Sciences, Dharwad- 580 005, Karnataka, India.

ABSTRACT

Jackfruit is a tropical and highly seasonal fruit. It is largest tree borne fruit in the world. Jackfruit consists about 29 per cent pulp, 54 per cent rind and 12 per cent seeds by weight. Seeds of jackfruit are edible and known to possess nutritional property. Jackfruit seed flour is utilized for value addition of food products and also as a source of starch. The present study was undertaken to investigate mineral composition and antioxidant profile of jackfruit seed flour. Hard variety of jackfruits were procured from a single tree situated at University of Agricultural Sciences, Dharwad campus. Ripe fruits were cut, seeds separated, dried and milled to flour. Jackfruit seed flour was analyzed for macro-minerals such as calcium, phosphorous, magnesium; micro-minerals such as iron, copper, zinc, manganese and antioxidants like phenols and tannins. Results indicated that calcium content of jackfruit seed flour was 234.24 ± 0.02 mg/100 g. Phosphorous and magnesium content was 105.93 ± 0.03 mg/100 g and 162.51 ± 0.02 mg/100 g respectively. Iron content in jackfruit seed flour was 12.55 ± 0.03 mg/100 g. Copper, zinc and manganese content was 4.25 ± 0.03 mg/100 g, 2.03 ± 0.02 mg/100 g and 2.02 ± 0.03 mg/100 g respectively. Phenolic content in jackfruit seed flour was 4.52 ± 0.01 mg gallic acid equivalent/g and tannin content was 2.12 ± 0.01 mg tannic acid equivalent/g. The study revealed that jackfruit seed flour is a good source of minerals and antioxidants. Hence consumption of jackfruit seeds and utilization of its flour needs to be enhanced.

KEY WORDS: Jackfruit seed, flour, micromineral, micromineral, antioxidants.

INTRODUCTION

Jackfruit (*Artocarpus heterophyllus* Lam.) is a largest tree-borne and highly seasonal fruit consisting about 29 per cent pulp and 54 per cent rind. Seeds make up to 12 per cent (Berry and Kalra, 1988) of total fruit weight. Jackfruit seeds are edible and are boiled or roasted for direct consumption or used in culinary preparation namely; *curry*, *bhaji*, *cutlet* etc. Though seeds are consumed and utilized but most of the time they are discarded/wasted or spoiled rapidly due to high moisture content. However, seeds are nutritious and can be converted to flour for better utilization and storage stability. Jackfruit seed flour contain moisture (11 - 14 %),

carbohydrates (60 - 70 %), crude protein (9 - 12 %), fat (1 %), crude fiber (2 - 3 %), total mineral matter (2 - 3 %) and calorific value of 320 - 360 kcal/100 g (Airani, 2007; Gupta *et al.*, 2011; Islam *et al.*, 2015). Seed flour is also used for value addition in traditional and novel products.

Nutrition plays an important role in maintaining good health. Micro nutrients like vitamins and minerals are protective nutrients essential in growth, development and maintaining good health. Antioxidants are non-nutritive substances that prevent oxidative damage by free radicals and reactive oxygen species. Dietary phenolic compounds, tannins and flavonoids exhibit



antioxidant activity (Araceli *et al.*, 2003). Hence, the present study was undertaken with the objective to analyze mineral composition and antioxidant profile of jackfruit seed flour.

MATERIALS AND METHODS

Hard variety of jackfruits were procured from a single tree situated at University of Agricultural Sciences, Dharwad campus. Ripe fruits were cut and seeds were separated. Jackfruit seeds were chopped uniformly, dried in a hot air oven at 45 °C until consecutive weights were constant. Dried seeds were milled to flour (Airani, 2007). Jackfruit seed flour analyzed for minerals and antioxidants.

Calcium estimation was carried out by titrimetric method (Oser, 1965), phosphorous was estimated colorimetrically (Ranganna, 1986), magnesium was estimated by ethylenediaminetetraacetic acid (EDTA) titrimetric method (Derderian, 1961). Microminerals (iron, zinc, copper and manganese) were estimated by wet digestion using triacid mixture (Anon., 2000). Total phenol estimation was carried out with the Folin - Ciocalteu reagent (FCR). Gallic acid was used as the standard and results were expressed as gallic acid equivalent (Anon., 2000). Tannins were estimated calorimetrically using Folin - Denis reagent (FDR). Tannic acid was used as the standard and results were expressed as tannic acid equivalent (Schander, 1970). All the analyses were carried out in triplicates and results were expressed as Mean \pm Standard Deviation (S.D.).

RESULTS AND DISCUSSION

Mineral composition of jackfruit seed flour

Minerals are inorganic substances, present in all body tissues and fluids. Although they yield no energy, they play important roles in many activities in the body (Soetan *et al.*, 2010). Calcium, phosphorous and magnesium are essential for carbohydrate metabolism, bone and teeth formation, enzyme activity and regulating the acid-alkaline balance in the body (Scarlbet, 1991 and Brody, 1994). Iron is essential nutrient for blood formation (Kittiphoom, 2012). Copper is involved in iron

metabolism. Manganese is a cofactor in several enzymes whereas zinc is essential part in more than 100 enzymes involved in energy metabolism (Huskisson *et al.*, 2007).

Mineral composition of jackfruit seed flour is presented in Table 1. Calcium content of jackfruit seed flour was 234.24 ± 0.02 mg/100 g. Phosphorous and magnesium content was 105.93 ± 0.03 mg/100 g and 162.51 ± 0.02 mg/100 g respectively. Iron content in jackfruit seed flour was 12.55 ± 0.03 mg/100 g. Copper, zinc and manganese content was 4.25 ± 0.03 mg/100 g, 2.03 ± 0.02 mg/100 g and 2.02 ± 0.03 mg/100 g respectively. Similar values for phosphorous (139.00 mg/100 g), magnesium (150.70 mg/100 g), copper (3.16 mg/100 g) and zinc (1.50 mg/100 g) in jackfruit seed was reported by Abedin *et al.* (2012). Ocloo *et al.* (2010) reported that jackfruit seed flour was rich in calcium (308.7 mg/100 g), magnesium (338.0 mg/100 g) and copper (1.04 mg/100 g). Banerjee and Datta (2015) recorded 13.07 mg iron and 1.45 mg copper per 100 g of jackfruit seed flour. Calcium, magnesium, iron, copper and manganese content in jackfruit seed flour was 166.10, 295.10, 1.30, 2.50 and 4.20 mg/100 g respectively (Okafor *et al.*, 2015). The difference observed may be attributed to the analytical methods used for estimation, the variety of jackfruit and the geographical location of the plant. Jackfruit seed flour is good source of minerals and hence has better nutritional value.

**Table 1 Mineral composition of jackfruit seed flour**

Minerals		(mg/100 g)
Macro minerals	Calcium	234.24 ± 0.02
	Phosphorous	105.93 ± 0.03
	Magnesium	162.51 ± 0.02
Micro minerals	Iron	12.55 ± 0.03
	Copper	4.25 ± 0.03
	Zinc	2.03 ± 0.02
	Manganese	2.02 ± 0.03

Mean ± S.D.

Phenols and tannins content of jackfruit seed flour

Phenols and tannins are the phytochemicals present in plant. They provide protection against cancer, cardiovascular disease, dementia, cataract, muscular degeneration, ageing and various other disorders associated with increased oxidative stress (Sirisha *et al.*, 2014). These phytochemicals act antioxidants which intercept free radicals and protect the cells from the oxidative stress (Nuttall *et al.*, 1999).

Phenols and tannins content of jackfruit seed flour are presented in table 2. Phenolic content in jackfruit seed flour was 4.52 ± 0.01 mg GAE/g and

tannin content was 2.12 ± 0.01 mg TAE/g. Similar result for phenolic content of 4.42 mg GAE/g in jackfruit seed flour was reported by Gat and Ananthanarayan (2015). Nair *et al.* (2012) reported that total phenolic and tannin content of jackfruit seed extract was 4.06 mg GAE/g and 1.98 mg GAE/g respectively. A strong relationship between phenolic content and antioxidant activity in fruits and vegetables has been reported (Odukoya *et al.*, 2005). Thus, the presence of phenols and tannins in jackfruit seeds add to its nutritional value and health benefits.

Table 2 Phenols and tannins in jackfruit seed flour

Phenols (mg GAE/g)	Tannins (mg TAE/g)
4.52 ± 0.01	2.12 ± 0.01

Mean ± S.D.

GAE – Gallic acid equivalent, TAE – Tannic acid equivalent

CONCLUSION

Jackfruit seed flour is a good source of nutrients like minerals and non-nutritive substances like antioxidants. Minerals and antioxidants play a vital role for growth, development and in maintaining good health. Even though jackfruit seeds are nutritious, most of the times they are wasted/discarded or spoiled rapidly. Therefore, consumption of jackfruit seeds and utilization of its flour at household and commercial level needs to be enhanced to improve nutritional security and gain better health benefits.

REFERENCES

1. Abedin, M. S., Nurrudin, M. M., Ahmed, K. U. and Hossain, A., 2012, *Nutritive compositions of locally available jackfruit seeds (Artocarpus heterophyllus) in Bangladesh. Intr. J. Biosci.*, 2(8): 1-7.
2. Airani, S., 2007, *Nutritional quality and value addition to jackfruit seed flour. M. H. Sc. Thesis, Univ. Agric. Sci., Dharwad (India).*
3. Anonymous, 2000, *Official Methods of Analysis of Association of Official Analytical Chemists, 20th Edition AOAC, Washington. D. C.*
4. Araceli, S., Camen, R. M., Guillermo, R. S., Salvador, M. and Rosa, M. G., 2003,



- Pharmacological compounds in selected herbs. *J. Agric. Food Chem.*, 46(1): 53-61.
5. Banerjee, S. and Datta, S., 2015, Effect of dry heat-treated jackfruit seed powder on growth of experimental animals. *J. Pharm. Bio. Sci.*, 10: 42-46.
 6. Berry, S. K. and Kalra, C. L., 1988, Chemistry and technology of jackfruit (*Artocarpus heterophyllus*) - A review. *Indian Food Packer*, 42: 62-76.
 7. Brody, T., 1994, *Nutritional Biochemistry*, Academic Press, New York, pp. 450-459.
 8. Derderian, M. D., 1961, Determination of calcium and magnesium in plant material with EDTA. *Anal. Chem.*, 33(12): 1796-1798.
 9. Gat, Y. and Ananthanarayan, L., 2015, Physicochemical, phytochemical and nutrimental impact of fortified cereal based extrudate snacks: Effect of jackfruit seed flour addition and extrusion cooking. *Adv. J. Food Sci. Tech.*, 8(1): 59-67.
 10. Gupta, D., Mann, S., Sood, A. and Gupta, R., 2011, Phytochemical, nutritional and antioxidant evaluation of seeds of jackfruit (*Artocarpus heterophyllus* Lam.). *Intr. J. Pharma Bio Sci.*, 2(4): 336-345.
 11. Huskisson, E., Maggini, S. and Ruf, M., 2007, The role of vitamins and minerals in energy metabolism and well-being. *J. Intr. Medical Res.*, 35: 277 - 289.
 12. Islam, M. S., Begum, R., Khatun, M. and Dey, K. C., 2015, A study on nutritional and functional properties analysis of jackfruit seed flour and value addition to biscuits. *Intr. J. Engg. Res. Tech.*, 4(12): 139-147.
 13. Kittiphoom, S., 2012, Utilization of mango seed. *Intr. Food Res. J.*, 19(4): 1325-1335.
 14. Nair, S. S., Nithyakala, C. M., Noronha, I. V., Sultana, N and Somashekharaiyah, B. V., 2012, Isolation and determination of nutritional and antinutritional compounds from the seeds of selected plant species. *J. Chem. Pharm. Res.*, 4(7): 3529-3534.
 15. Nuttall, S. L., Kendall, M. J. and Martin, U., 1999, Antioxidant therapy for the prevention of cardiovascular disease. *Quarterly J. Med.*, 92: 239-244.
 16. Ocloo, F. C. K., Bansa, D., Boatun, R., Adom, T. and Agbemavor, W. S., 2010, Physicochemical, functional and pasting characteristics of flour produced from jackfruits (*Artocarpus heterophyllus*) seeds. *Agric. Bio. J. North America.*, 1: 903- 908.
 17. Odukoya, O. A., Jenkins, M. O. and Ilori, O. O., 2005, The use of selected Nigerian natural products in management of environmentally induced skin damage. *Pakistan J. Biol. Sci.*, 8: 1074- 1077.
 18. Okafor, O. E., Ezeanyika, L. U. S. and Ujowundu, C. U. O., 2015, Effect of traditional processing techniques on the proximate and mineral composition of jackfruit (*Artocarpus heterophyllus*) seeds. *Intr. Conf. Food Sci. Chem. Envir. Engg. Kuala Lumpur*, August 25-26. pp. 1-4.
 19. Oser, B. L., 1965, *Hawk's Physiological Chem.*, McGraw-Hill, New York, pp.10-40.
 20. Ranganna, S., 1986, *Handbook of Analysis and Quality Control for Fruit and Vegetable Products*, 2nd Edition, Tata McGraw-Hill Publishing Company Limited, New Delhi, pp. 9-10, 105-106.
 21. Scalbert, A., 1991, Antimicrobial properties of tannins. *Phytochem.*, 30: 3875-3883.
 22. Schander, S. H., 1970, *Tannins In: Methods in Food Analysis*, 10th Edition, Academic press, New York, 709.
 23. Sirisha, N., Rao, K. V. R., Rao, D. B. and Rao, T. R., 2014, Evaluation of antioxidant activities, phytochemical constituents and protein profiling of five varieties of jackfruit (*Artocarpus species*) seeds. *Intr. J. Pharma Sci.*, 4(4): 626-631.
 24. Soetan, K. O., Olaiya, C. O. and Oyewole, O. E., 2010, The importance of mineral elements for humans, domestic animals and plants: A review. *African J. Food Sci.*, 4(5): 200-222.



A STUDY ON CONSUMER SATISFACTION TOWARDS GOOD DAY BISCUITS WITH SPECIAL REFERENCE TO COIMBATORE CITY

Mr. S. Muruganatham

*Assistant Professor, Department of Commerce with Professional Accounting,
Dr. N.G.P. Arts and Science College, Coimbatore*

Mrs. S. Menaka

*Student, Assistant Professor, Department of Commerce with Professional Accounting,
Dr. N.G.P. Arts and Science College, Coimbatore*

INTRODUCTION

Biscuits are a very significant part of the food industry in most countries of the world. A biscuit is a small baked products; the exact meaning varies markedly in different parts of the world. The origin of the word “biscuits” is from Latin via Middle French and means “cooked twice. During the time of Louis XIV, soldiers’ biscuits were known as “stone bread.”

Biscuits are a variety of quick breads popular in different forms throughout the United States. They are made from a combination of flour, shortening, leavening and milk or water. This simple dough is generally rolled out, cut into small rounds, baked and served hot.

STATEMENT OF THE PROBLEM

The growth of every business largely depends upon the satisfaction level of the consumer. Good Day being a popular brand of Britannia limited has a wide range of consumers. Exit in the market for more than 120 years. This study has been undertaken to know the satisfaction level of the consumer of Good Day and its impact towards the success. This study is an attempted to examine the factors which influence the consumer to buy Good Day biscuits. It is also finding out the consumer satisfaction towards good day biscuits and also expectations consumer with good day biscuits.

OBJECTIVES OF THE STUDY

- To study about customer satisfaction towards quality, availability, price of good day biscuits.
- To know awareness about the good day biscuits among the public.
- To study the relationship between the demographic variables and factors affecting of consumer

RESEARCH METHODOLOGY

Descriptive research design had been used in this study.

Sample size: 120 respondents

Sampling Unit: Consumers who are consuming good day biscuits.

Data used: Primary data as well as secondary data

Primary data: Questionnaire

Secondary data: Past Research Papers

Area of study: The study is conducted only in Coimbatore City.

Sampling method: Convenient sampling is used in the research.

Statistical tool used:

- Percentage analysis
- Likert scale
- Ranking analysis

**REVIEW OF LITERATURE**

Dr.M. Rajarajeswari March (2017) “A Comparative study on brand loyalty of biscuits (with special preference to Britannia and Parle) in Coimbatore City”. The main purpose of the study is to be measure the brand loyalty of the sample respondents to the Britannia and Parle brand biscuits and know the main factors that influence their brand loyalty. To evaluate the taste difference in both the products. The research was carried out in Coimbatore district, convenient sampling method was used to select the sample.

Hemant. J. Katole Jan (2018) “Buying Behavior and Brand Loyalty of biscuit Consumer in India”. Consumer in India”. Consumer of product is often separate temporarily from the decision to buy those products. The research reported here examines the strategies consumer use when making multiple purchase in a product category for future consumption. To know the brand loyalty based on buying behavior of

consumer. Hence research concludes that consumer is branding conscious where age plays an important role while buying biscuits.

HISTORY AND PROFILE OF THE STUDY

Britannia Industries Limited is an Indian food-products corporation based in Bangalore, India. . The company was established in 1892 by a group of British businessmen with an investment of Rs.295. It is the first bakery company in India to remove trans fats from its biscuits. Britannia innovates for strong presence in health and nutrition space.

Initially, biscuits were manufactured in a small house in central Kolkata. Later, the enterprise was acquired by the Gupta brothers mainly Nalin Chandra Gupta, a renowned attorney, and operated under the name V.S Brothers.

ANALYSIS

S.NO	PARTICULARS	NO. OF. RESPONDENTS	PERCENTAGE
1	Quality	54	45
2	Price	16	13.3
3	Ingredients	35	29.2
4	Brand Image	15	12.5
	TOTAL	120	100

(Source: Primary Data)

INTERPRETATION

The table 4.1.12 shows that 45% of the respondents are purchase by Quality and the 13.3% of the respondents are purchase by Price and 29.2% of the respondents are purchase by Ingredients and the 12.5% of the respondents are purchase by Brand Image.

INFERENCE

Most 37.5% of the respondents are choosing the Good Day Biscuits on the basis of Quality

TABLE SHOWING THE DISTRIBUTION OF RANKING FOR FLAVOUR FACTORS OF GOOD DAY BISCUITS

SNO	FLAVOUR	RANK I	RANK II	RANK III	RANK IV	RANK V	TOTAL SCORE	RANK
1	Cashew	27(5)	22(4)	30(3)	14(2)	27(1)	368	3
2	Nuts Cookies	14(5)	40(4)	23(3)	29(2)	14(1)	371	2
3	Chocolate	33(5)	20(4)	33(3)	19(2)	15(1)	397	1
4	Butter	22(5)	23(4)	29(3)	29(2)	17(1)	364	4
5	Choco-Nut	23(5)	21(4)	20(3)	25(2)	31(1)	340	5

(Source: Primary Data)

INTERPRATATION

The table 4.3.1 shows that the out of 120 respondents, Cashew is in the rank 3, Nuts Cookies is in the rank 2, Chocolate is in the rank 1, Butter is in the rank 4 and Choco-Nut is in the rank 5

INFERENCE

If resulted that Chocolate is in rank 1 and it influences the respondents to prefer CHOCOLATE FLAVOUR.



FINDINGS

SIMPLE PERCENTAGE ANALYSIS

- Majority 55.8% of the respondents are Female
- Most 47.5% of the respondents are 21 years-30 years
- Majority 56.7% of the respondents are the Under Graduate
- Majority 56.7% of the respondents Educational qualification are Students
- Majority 56.7% of the respondents are earning Rs. 40,001- Rs. 50,000
- Majority 74.2% of the respondents are Unmarried.
- Majority 56.7% of the respondents come to know about Good Day biscuits by Advertisement.
- Most 33.3% of the respondents are buy the good day biscuits from the Super Market
- Most 37.5% of the respondents prefer good day biscuits when they are break time.
- Most 45% of the respondents come to know about Good Day biscuits by Television.
- Majority 50% of the respondents consuming good day biscuits Once in a week
- Most 37.5% of the respondents are choosing the Good Day Biscuits on the basis of Quality
- Most 30.8% of the respondents like Cashew flavor of Good Day Biscuits.
- Most 35% of the respondents prefer to eat good day biscuits with Tea.
- Majority 94.2% of the respondents are fully satisfied on Good Day Biscuits.

LIKERT SCALE ANALYSIS

- Likert scale value is 4.55 greater than the middle value(3), so the consumers are satisfied in the PRICE.
- Likert scale value is 4.7 greater than the middle value(3), so the consumers are satisfied in the QUALITY.
- Likert scale value is 4.35 greater than the middle value(3), so the consumers are satisfied in the TASTE.
- Likert scale value is 3.81 greater than the middle value(3), so the consumers are satisfied in the FLAVOUR.
- Likert scale value is 3.41 greater than the middle value(3), so the consumers are satisfied in the PACKING.
- Likert scale value is 3.99 greater than the middle value (3), so the consumers are

AGREE that the children prefer the Good Day Biscuits Mostly.

RANKING ANALYSIS

- If resulted that Chocolate is in rank 1 and it influences the respondents to prefer CHOCOLATE FLAVOUR.

SUGGESTIONS

- Britannia industries may bring a variety of new tastes and flavors in Good Day Biscuits.
- The company may provide special offer to the customer.
- They also use innovative packing methods for covering the biscuits packs.
- They may concentrate in Advertisements in order to have new consumer for their product.
- The company to retain the its market leadership should concentrate in sales promotion activities, which would enhance the sales of Good Day Biscuits.

CONCLUSION

In today's scenario, customer is the king because he has got various choices around him. If the company is not capable of providing consumers the desired result then the consumer will definitely switch over to the competitor. Therefore to survive in this cut throat competition, the company needs to be the best. That Britannia Biscuits has gained acceptance by the customer and has huge potential to expand its market share and become leaders in few of its biscuits category Britannia is most popular amongst its users mainly because of its taste, brand name and innovativeness

REFERENCE

1. Dr. M. Rajarajeswari March (2017) "A Comparative study on brand loyalty of Biscuits with special preference to Britannia and Parle) in Coimbatore city". *International Journal commerce and Management Research* ISSN: 2455- 1627, Impact: *RJIF* 5.22 www.managejournal.com volume 2;issue3; page no. 95-97
2. Hemant.J. Katole Jan (2018) "Buying Behavior and Brand Loyalty of Biscuit Consumer in India". *IMPACT: International Journal of Research in Business Management*(IMPACT:IJRBM) ISSN(P):2347-4572;ISSN(E):2321-886X Vol.6, Issue 1, Jan 2018,19-30
3. S. Gomathi and G. Kothandapani March (2017) "A study on consumer buying behavior on Britannia Marie Gold Biscuits". *IJMh- International Journal*



*of Management and Humanities. Volume: 04 Issue:
03 2017 ISSN:2349-7289 www.researchscrip.com*

4. *Mr. S.D. Nithyananth, Mr. B. Vingeshwaran (2015), "A study on consumer satisfaction towards Britannia in Madurai city IOSR Journal of Business and management (IOSR- JBM) e-ISSN; 2277-487X, p-ISSN: 2319-7668, PP 17-21 www.iosrjournal.org*



THE CHANGING PERCEPTION OF MARKETING COMMUNICATION- TOOLS & PURPOSES: A DESCRIPTIVE STUDY

Dr. Sanjay Shrivastava

Associate Professor (Business Communication), Technology Management Department, SVKM's NMIMS, MPSTME, Shirpur Campus, Shirpur, Dhule, Maharashtra, India

ABSTRACT

Marketing communication has changed to a great extent with the emergence of latest technological devices. Marketing communication has changed to a great extent with the arrival and invent of new technological devices. Belch, George E. & Belch, Michael A. (1998), are of the opinion that as a result of constant development across past several years companies across the world have put their best efforts to master the art and artifice of mass marketing. Mass marketing is a highly strategic effort for selling the products to a large pool of customers. As a result, companies could successfully develop the effective ways of making such selling campaigns through an effective mass media advertizing. As a routing practice, companies invest millions to reach to a large chunk of customers by the mass media communication through repeated advertisements.

KEYWORDS: *Marketing, Communication, Direct-Marketing, Telemarketing, Internet.*

1. INTRODUCTION

In the present times of marketing communication era, the area experts are constantly trying to evaluate, analyze and execute some other unapplied dimensions of marketing communication. Following into the trend many top notch Indian companies are constantly investing the large share of their earning to reach to a great mass by adopting to the ways of marketing communication.

2. THE CHANGING COMMUNICATION ENVIRONMENT

Past few years the communication environment has changed because of many external and internal influences. Strydom J. W., Jooste C. J. and Cant M.C. (2000), had the opinion that the globalization of business and business relations has put its inevitable influences on communication. Following into the trends of world's top brands and the new philosophies of the communication researchers has set new strategies and techniques of communication. Strydom, H. (1998) believed that to win the utmost objective of any business the replication of marketing communication has introduced many new elements. Two streams are worth noticing to decide the latest changes, first, in present scenario companies are shifting away from mass marketing exercises because of the growing

culture of fragmented markets for specific group of users and customers. In addition to that, the market communications are involved in introducing new strategies and programs to develop highly focused marketing communication programs. The modern marketing communicators are putting in best efforts to design an effective marketing communication program which caters to the needs of fast growing micro markets. Another major change in the approach and access is the intrusion of latest technologies into the business processes. Kotler & Armstrong (2010) affirmed that the computer and information technology are constantly making the process and access faster towards segmented marketing and associated communication process. The latest information technology has revolutionized the entire business information systems supporting to a great extent to the modern marketers to keep closer track of customer along with customer's needs, wants and buying habits and psyche. Such latest and fast changes from mass marketing to the segmented market approach have been the influencing factors to the remodeling of marketing communications. Kotler & Armstrong (2013) affirmed that now, we have marketing communication approaches more focused, customized, specialized, and highly targeted



communication efforts beyond the traditional practices.

3. GROWTH OF DIRECT MARKETING

In present times, out of all elements of marketing communication the direct marketing has emerged as the most visible face and the most acknowledged event to make access to customers. Yeshin, T. (1998) observed that apart from the traditional approach of mass marketing programs, now the emphasis is on one to one marketing including marketing communications strategized for individual customer approach. The process and approach of direct marketing encompasses direct communications with segmented and targeted customers to acquire the immediate response of the customer or consumer. It is noticeable that through direct marketing the companies can successfully study, evaluate, approach and communicate to customers their marketing offers. Strydom, H. (1998) accepted that however, the direct marketing is the most flourishing strategy of marketing communication in present times being successfully and wholehearted adopted by the modern companies involved in producing all sorts of products.

4. DIRECT-MAIL MARKETING

Direct mail marketing includes direct mail and catalogue marketing, telemarketing, television marketing and on-line shopping. It is evidential that there has been a rapid growth in business because of direct marketing or direct mail marketing for its higher ability to one-to-one communication. Direct marketing provides the opportunity to target the market on selective basis. (Kotler & Armstrong, Marketing: An Introduction, 2000) "Direct mail permits high target-market selectivity, can be personalized, is flexible, and allows easy measurement of results. Direct mail has proved very successful in promoting books, magazines subscriptions, and insurance. Increasingly, it is being used to sell novelty and gift items, clothing, gourmet foods, and industrial products. Direct mail is also used heavily by charities, which raise billions of dollars each year and account for about 25 per cent of all direct-mail revenues."

5. CATALOGUE MARKETING

The catalogue marketing is supporting business through various dimensions. The catalogue marketing has become one of the most popular and effective ways of marketing communication. The potential companies and general-merchandise retailers like BPL and Lakme exercise conduct selling of a full product line of merchandise by catalogues. Despite that, these giants companies have been challenged by thousands of special featured catalogues which are effective enough to serve highly

customized market niches. It is true that many consumers enjoy receiving catalogues and sell them further to the book stores and magazines stands. Kotler & Armstrong (2010), accepted that in present times, many a business-to-business markets depend on catalogs to initiate the business. Catalogs come into different shapes like simple brochure, videotapes or computer disk, or three – ring binder or book catalog.

6. TELEMARKETING

Telemarketing is the choice of contemporary business houses. Telemarketing has been one of the most celebrated mediums of communicating sales message through this mode of customer seller interaction. Telemarketing is a practice of using the telephone or mobile phones to inform, pursue or sell directly to consumer including satisfying queries of the customer through sales persuasion techniques. (Kotler & Armstrong, Principals of Marketing, 2013) "Marketers use outbound telephone marketing to sell directly to consumers and businesses. Outbound toll-free 800 numbers are used to receive orders from television and radio aids, direct mail, or catalogs. The average household receives 19 telephone sales calls each year and makes 16 calls to place orders. During 1990, AT&T logged more than 7 billion 800-number calls. Business-to-business marketers use telemarketing extensively. In fact, more than \$115 billion worth of industrial products were marketed by phone last year. Most consumers appreciate many of the offers they receive by telephone/mobile. Properly designed and targeted telemarketing provides many benefits, including purchasing convenience and increased product and service information."

7. TELEVISION MARKETING

This modern mode of marketing communication has a very mass access to the customers. The communication about the products by various business houses is being majorly casted by television on every day, every hour basis. (Kotler & Armstrong, Principals of Marketing, 2010) "Television Marketing takes one of two major forms. The first is direct response advertizing. Direct marketers air television spots, often 60 or 120 seconds long that persuasively describe a product and give customers a toll-free number for ordering. Television viewers often encounter 30-minute advertising programs, or information commercials-for a single product."

8. INTERNET/ ON-LINE SHOPPING

Internet is playing the most active role in bringing the company and products at one common platform to interact and make purchasing decisions. Maddox, K. (2005) observed "The Internet is no longer simply an option in a company's communication strategy. It is an essential element.



The Internet, and especially the World Wide Web, is relatively new to consumers. Millions of consumers are now regularly logging in online. They are still, however, in the process of forming what they want to do when they get there. Like someone moving to a new city, consumers will be reevaluating with whom they will do business". Now, the process in vogue is that an on-line computer-based shopping is conducted through interactive and on-line computer services where a two-ways system is established to link consumers with sellers electronically. The most significant thing is that these services create computerized catalogs of products and services offered by producers, retailers, bank, travel organizations, and others. Consumers use a home computer to look into the systems through cable or telephone lines.

9. RELATIONSHIP MARKETING

In modern age of business, the relationship marketing is in its full swing. Almost all business houses across the world have recognized the importance of relationship in marketing. Today, relationship with the customer, understanding customer's attitude and solving and supporting consumer's purchase decision has got a significant place in the overall marketing and its communication strategy. Lepla, F. J., & Parker, L. M. (1999) agreed that the fresh approach to marketing activity is that customers do not buy things as a general attitude rather they shop solutions to existing problems and that too successful business concerns aspire unique insight into customers and the problems they face. When the plan and process of business is executed in this style it helps strengthen customer relationship. Such approach supports the customer relationship positively and such relationships with the buyers become the key to attracting high sales and holding them for a very longer period of time. Nurturing such system with the customer care and maintaining relationships is an ongoing journey forever. Kotler & Armstrong (2000), believed that most of the organizations are better at developing interpersonal with their customers and listen to them carefully and take necessary measure to solve customers' problems. In olden days the marketers' practiced means of communication was the one sided i.e. from the company only but now, they are expected to develop a two way communication which means listening to the voice of their customers also.

10. DIRECT MARKETING DATABASE

In modern times, marketers focus on database to segment and to make an effective approach to a customer. A marketing database is a well-organized and tabulated database for an individual customer or prospective consumer which mainly includes geography, psychographic, demographic and the

buying behavior pattern. Thus, the approach of maintain database of consumers can be effectively used to find the right prospect and tailor products or services. Most of the companies are in practice of structuring information sheet to target marketing communication and focusing selling efforts.

11. INTEGRATED MARKETING COMMUNICATIONS

Since the advent of new concept referred as Integrated Marketing Communication (IMC) most of the companies are adopting this methodological approach to make a consolidated access and approach to a customer. Cant, M C & Machado, R. (1998) observed that in this concept, the marketers meticulously integrate as well as coordinate various communication channels like mass media, advertising, sales promotion, personal selling, direct marketing, public relations, product packaging and the like to deliver a transparent and clear, consistent and effective message about the organization and its products. The company and marketing experts' decide strategies and roles that the various promotional tools will play and the extent to which each of them will be utilized. (P. Kotler, Integrated Marketing Communication Strategy, Chapter 13, P 542) "It carefully coordinates the promotional activities and the timing of when major campaigns take place. It keeps a track of its promotional expenditures by product, promotional tool, product life-cycle stage, and observed effect in order to improve marketing strategy... Integrated marketing communications produces better communication consistency and greater sales impact...It leads to total marketing communication strategy aimed at showing how the company and its products can help customers solve their problems."

12. THE NEW ADVERTISING MEDIA

In the present scenario as the new techniques and tools of marketing communication is emerging and as the technology of communication is advancing the approach of the marketers are focusing on to segment the mass in fragmented markets for their marketing approach and persuasive access. In order to capture best to these small chunks of prospective customers, marketers are looking beyond Television, radio, print, and billboard and other traditional ways of advertising to let their message internalized. Marketers put hard efforts to get their message imprinted through the generalized ways of communication like through movies, supermarket wardrobes, e-mails, and telecommunication. The new recognized range of marketing communication tools are:

13. DIGIZINES (or e-zines)

Digizines is an online magazine which generally shares some features with a blog and also



with online newspapers, but e-zines is distinct in its approach because it always has an editorial control. Normally, magazines seldom have a flock of editors or a system of editorial boards who review, analyze and evaluate technically all the submissions and put a check as profound quality controller. Barker, R & Du Plessis, DF. (2002), observed that, they ensure such scripts have the worth of quality material that meets the expectations of the publishers as well as readers. Online magazines are also known as webzines. An e-zine is a more official term connotes to small magazines and newsletters sent through electronic modes, However, some of the social groups evoke the terms cyberzine and hyperzine intending to indicate electronically distributed scripts resources while some online magazines are referred as electronic magazines.

14. INTERACTIVE TELEVISION

Interactive television represents a continuous flow of interactivity (TV on/off, volume, changing channels) to moderate interactivity (simple movies without player controls) and high quantum of interactivity in which an audience member affects the program being watched. The self-explanatory and obvious example of this can be understood by any kind of real-time interaction on the screen where the audience vote results decides and the same is reflected in how the show continues or deviates.

15. FAX-ON DEMAND

First introduced in 1989, Fax on Demand (FaxFacts, 1989) "allows callers to retrieve information via fax on the same call (from a fax machine) or by call back (from a phone, "2 call"). In today's Internet economy fax is still the preferred form of communication for classified or legal documents. Fax on Demand provides a complement to your corporate website as 99.9% of all businesses own a fax machine, but not nearly as many have Internet access."

(FaxFacts, 1989) "Fax on Demand is the ideal electronic assistant for companies and organizations that need to have information constantly available to their customers in places other than their website. Companies that provide sales, product, or other timely information to customers by fax find themselves miles ahead of the competition with Fax Facts Fax-on-Demand. Fax-on-Demand makes an office more efficient, saving money and valuable time. Fax Facts reduces overhead by handling these calls for information, thus reducing expenses for staffing, phones, postage, and printing. Telephone bills are lower because Copia's one-call technology downloads documents on the customer's telephone

call. Customers appreciate immediate access to fresh information."

REFERENCES

1. Barker, R & Du Plessis, DF. (2002), *Towards an integrated communication profession: a pilot study*, *Communicare* 22(1):1-28.
2. Belch, George E. & Belch, Michael A. (1998), *Advertising and Promotion — An Integrated Marketing Communications perspective*, Irwin/McGraw-Hill, Boston, Mass, 8.
3. Cant, M C & Machado, R. (1998), *Marketing Success Stories, 3rd Edition*, Halfway House, International Thompson, 1.
4. Kotler & Armstrong (2000), *Marketing: An Introduction, Chapter 13*, Dorling Kingsley (India) Pvt Ltd. 7th Edition, Pearson Education, 489.
5. Kotler & Armstrong (2000), *Marketing: An Introduction, Chapter 13*, Dorling Kingsley (India) Pvt Ltd. 7th Edition, Pearson Education, 489.
6. Kotler & Armstrong (2010), *Principals of Marketing, A South Asian Perspective, 13th Perspective, Designing A Customer Driven Strategy & Mix*, Dorling Kingsley (India) Pvt. Ltd., 422.
7. Kotler & Armstrong (2010), *Principals of Marketing, A South Asian Perspective, 13th Perspective, Designing A Customer Driven Strategy & Mix*, Dorling Kingsley (India) Pvt. Ltd., 422.
8. Kotler & Armstrong (2013), *Principals of Marketing, 12th Edition, Direct & Online Marketing, Chapter 17*, 453.
9. Kotler & Armstrong (2013), *Principals of Marketing, 12th Edition, Direct & Online Marketing, Chapter 17*, 453.
10. Lepla, F. J., & Parker, L. M. (1999). *Brand driven: The route to integrated branding through leadership*. New York: Kogan Page.
11. Maddox, K., (2005), "The fall and rise of b-to-b," *B to B*, v90n7, pp. 19-21.
12. Strydom J. W., Jooste C. J. and Cant M.C. (2000), *Marketing Management, 4th Edition*, Kenwyn: Juta, P. 5.
13. Strydom, H. (1998). *Ethical aspects of research in the caring professions*, in A.S. De Vos (Ed), *Research at Grass Roots: A primer for the caring professions*. Pretoria: Van Schaik, 23–36, 17.
14. Strydom, H. (1998). *Ethical aspects of research in the caring professions*, in A.S. De Vos (Ed), *Research at Grass Roots: A primer for the caring professions*. Pretoria: Van Schaik, 23–36, 17.
15. Yeshin, T. (1998). 'Marketing Communications Strategy 1998-99', Butterworth-Heinemann, Oxford. P. 6-8.



A STUDY ON CONSUMER SATISFACTION TOWARDS OPPO MOBILES WITH SPECIAL REFERENCE TO COIMBATORE CITY

Mr. A. David.

Assistant Professor, Department of commerce with Professional Accounting, Dr. N.G.P Arts and Science College, Coimbatore

Anish Kumar.K

Student of III B.com (PA), Department of commerce with Professional Accounting, Dr. N.G.P Arts and Science College, Coimbatore

ABSTRACT

A mobile phone, cell phone, or hand phone sometimes shortened to simply mobile, cell or just phone, is a portable telephone that can make and receive calls over a radio frequency link area. This study is related to the customer satisfaction of oppo mobiles. This study would enable to develop the way in which it creates new product and develops new and real markets with a view to offering its customers fitter service. There are number of manufactures in market to manufacture the mobile phones in the desired quality for reasonable price. To identify the opinion of the customer about oppo mobiles. For the purpose of analysis, the data has been collected from 80 customers from the selected sampled respondents in Coimbatore city OPPO The data have been analyses by using the following statistical tools Simple Percentage analysis, Likert scale analysis, Ranking analysis. Majority 61% of the respondents are camera. Likert scale value is 2.05 which is greater than 2. So the respondents are important to the pricing factor. If resulted that design is in the rank 1 and it is influencing the respondents to prefer design. They may concentrate in advertisement in order to have new consumer for their product The factors considered by the customer before purchasing smartphones are low price. Latest features camera quality, reliability,

INTRODUCTION

Every human being is a consumer of different produces. If there is no consumer, there is no business. Therefore, consumer satisfaction is very important to every business persons.

Satisfaction of customer is essential for retention of customer's and for continuous sales of the products and services of the company to customers. This establishes the needs for and the importance of customer satisfaction. The satisfaction of consumers is different one to another. Became, each customer has the different behaviour in their life. So, the marketer satisfy the consumer, he must very well know the behaviour of consumer.

The study is consumer preference and satisfaction of oppo mobile phones in Coimbatore city.

A mobile phone, cell phone, or hand phone sometimes shortened to simply mobile, cell or just phone, is a portable telephone that can make and receive calls over a radio frequency link while the user is moving within a telephone service area.

STATEMENT OF PROBLEM

The numbers of mobile phone users are increasing day by day in India. Companies make a aggressive advertising, marketing and promotional efforts which compel other manufactures to focus on their marketing efforts as well. These companies resort



to price reductions, new function additions, value additions and focus advertising and promotional campaigns. There are number of manufactures in market to manufacture the mobile phones in the desired quality for reasonable price.

SCOPE OF THE STUDY

This study is related to the customer satisfaction of oppo mobiles. This study would enable to develop the way in which it creates new product and develops new and real markets with a view to offering its customers fitter service. The importance of the marketing power is to combined with its current marketing strategy, solve countermeasures for the existing problems, make steady growth.

OBJECTIVES OF THE STUDY

- To identify the opinion of the customer about oppo mobiles
- To find out the factors for the purchase of oppo mobiles
- To measure the level satisfaction of the customers on oppo mobiles

RESEARCH METHODOLOGY

Sample size

The sample of 80 respondents was chosen for the study.

Area of the study

This study is conducted within the Coimbatore city.

REVIEW OF LITERATURE

- ❖ **Tajzadeh Namin A. A.; Rahmani Vahid; Tajzadeh Namin Aidin (2012)** analysed that the process of deciding over (choosing) a brand may be influenced by situation and content. The findings suggest a significant relationship between the variables “brand attitude”, “corporate attitude”, and “product (cell phone) choice”. In addition, no significant relationship was found between

individual decision-making processes (independent or mediated) and product choice.

- ❖ **Androulidakis; G. Kandus (2011)** correlated the brand of mobile phone to users’ security practices, Users show different behavior in an array of characteristics, according to the brand of the mobile phone they are using. As such, there is a categorization of areas, different for each brand, where users are clearly lacking security mind, possibly due to lack of awareness. Such a categorization can help phone manufacturers enhance their mobile phones in regards to security, preferably transparently for the user.
- ❖ **Oyeni, Omotayo Joseph - Abioudun, Abolaji Joachim (2010)** emphasis on customer loyalty and customer switching cost. Switching cost is one of the most discussed contemporary issues in marketing in attempt to explain consumer behaviour. The present research studied switching cost and its relationships with customer retention, loyalty and satisfaction in the Nigerian telecommunication market. The study finds that customer satisfaction positively affects customer retention and that switching cost affects significantly the level of customer retention.

DATA ANALYSIS AND INTERPRETATION

The data collected from the samples have systematically applied and presented in tables under various headings in the following pages. They were also arranged in such a way that, a detailed analysis can be made so as to present suitable interpretations for the same. The data have been analyses by using the following statistical tools.

- Simple Percentage analysis
- Likert scale analysis
- Ranking analysis

**SIMPLE PERCENTAGE ANALYSIS****PURCHASE DECISION OF OPPO PRODUCT OF THE RESPONDENTS**

S.NO	PURCHASE DECISION	NO.OF. RESPONDENTS	PERCENTAGE
1	Picture quality	37	46
2	Audio quality	11	14
3	Media playback	8	10
4	User interface	24	30
	TOTAL	80	100

*(Source: primary data)***INTERPRETATION**

The table 4.1.7 shows that 46% of the respondents are picture quality and the 14% of the respondents are audio quality and the 10% of the

respondents are media playback and the 30% of the respondents are user interface

Majority 46% of the respondents are picture quality

LIKERT SCALE ANALYSIS**THE PURCHASE DECISION OF RESPONDENTS OF BRANDIMAGE FACTORS OF OPPO MOBILE**

S.NO	FACTORS	NO.OF. RESPONDENTS	LIKERT SCALE VALUE(X)	TOTAL(FX)
1	Important	23	3	69
2	Neutral	45	2	90
3	Not important	12	1	12
	TOTAL	80		171

*(Source: primary data)***INTERPRETATION**

Likert scale = $\frac{\sum(Fx)}{\text{Total number of respondents}}$
 $= \frac{171}{80}$
 $= 2.1375$

INFERENCE

Likert scale value is 2.1375 which is greater than 2. So the respondents are neutral to the brandimage factor.

**RANK ANALYSIS****THE PREFERENCE OF RANKING FOR FEATURES OF THE OPPO MOBILE OF THE RESPONDENTS**

S.NO	TYPES	RANK I	RANK II	RANK III	RANK IV	RANK V	RANK VI	TOTAL SCORE	RANK
1	Camera	20(6)	13(5)	17(4)	9(3)	10(2)	11(1)	311	2
2	Battery	14(6)	22(5)	10(4)	14(3)	12(2)	8(1)	308	4
3	Inbuild Application	10(6)	12(5)	17(4)	22(3)	13(2)	6(1)	286	6
4	Gaming	22(6)	11(5)	14(4)	12(3)	10(2)	11(1)	310	3
5	Ram	17(6)	12(5)	10(4)	20(3)	14(2)	7(1)	297	5
6	Design	23(6)	10(5)	15(4)	12(3)	9(2)	11(1)	313	1

*(Source: primary data)***INTERPRETATION**

The tale 4.3.1 shows that the out of 80 respondents, camera is in the rank 2, battery is in the rank 4, inbuild application is in the rank 6, gaming is in the rank 3, ram is in the rank 5, design is in the rank 1

INFERENCE

If resulted that design is in the rank 1 and it influences the respondents to prefer design

FINDINGS**SIMPLE PERCENTAGE ANALYSIS**

- Majority 55% of the respondents are female
- Majority 71% of the respondents are 18years-25years
- Majority 70% of the respondents are unmarried
- Majority 62% of the respondents are graduate
- Majority 64% of the respondents are students
- Majority 59% of the respondents are earning up to 10000

LIKERT SCALE ANALYSIS

- Likert scale value is 2.025 which is greater than 2. So the respondents are important to the quality factor

- Likert scale value is 2.1375 which is greater than 2. So the respondents are neutral to the brandimage factor
- Likert scale value is 2.05 which is greater than 2. So the respondents are important to the pricing factor

RANK ANALYSIS

- If resulted that design is in the rank 1 and it influences the respondents to prefer design
- If resulted that camera is in the rank 1 and it influences the respondents to prefer camera

SUGGESTIONS

- ✓ It is nice brand for a long period of time.
- ✓ The company may provide special offer to the customer
- ✓ They may concentrate in advertisement in order to have new consumer for their product
- ✓ The company to retain the its market leadership should concentrate in sales promotion activities, which would enhance the sales of oppo moiles
- ✓ Oppo brand performance is made up by the quality of its smart phones & its innovative features & functions



CONCLUSION

- ❖ Majority of the customers are satisfied with the OPPO mobiles because of its good quality, reputation, easy availabilities.
- ❖ From the survey conducted it is observed that OPPO mobiles has a good market share.
- ❖ From the study conducted the following conclusions can be drawn. In order the dreams come into reality and for turning liabilities into assets one must have to meet the needs of the customers
- ❖ The factors considered by the customer before purchasing smartphones are low price. Latest features camera quality, reliability.

REFERENCE

1. *Tajzadeh namin A.A.: Rahmani vahid ; Tajzadeh namin aidin (2012) "A study on consumer statisfaction towards oppo mobile with special reference to Coimbatore city". IJMh- International Journal of Management and Humanities. Volume: 04 Issue: 03 2017 ISSN:2349-7289 www.researchscript.com*
2. *Androulidakis ; g.kandus (2011) "correlated the brand of mobile phone to users' security practices,. Users show different behavior in an array of characteristics ". IMPACT: International Journal of Research in Business Management(IMPACT:IJRBm) ISSN(P):2347-4572;ISSN(E):2321-886X Vol.6, Issue 1, Jan 2018,19-30*
3. *Oyeniya, Omotayo joseph – abioudun, abolaji Joachim (2010) " emphasis on customer loyalty and customer switching cost. Switching cost is one of the most discussed contemporary issues in marketing in attempt to explain consumer behaviour ". Pacific Busines Review International Volume, www.pbr.co.in*

WEBSITES

1. Shodhganga.inflibnet.ac.in
2. www.indianjournals.com
3. www.iosrjournals.org
4. Info.dogpile.com



A STUDY ON CUSTOMER SATISFACTION TOWARDS MOBILE PHONE IN COIMBATORE CITY

Mr. P. Kanagaraj

*Assistant Professor, Department of Commerce with Professional Accounting,
Dr. N.G.P Arts and Science College, Coimbatore*

Shrinidhi. S

*III B.Com (PA), Department of commerce with Professional Accounting,
Dr. N.G.P Arts and Science College, Coimbatore*

ABSTRACT

Mobile phones are getting smarter each day. In view of the rapid development, multi-functionality, ubiquity and connectivity of mobile devices, it offers a new and potentially powerful market for the mobile phone users. The objective of the study is to identify the mobile phone preferred by the respondents, to analyse the satisfaction of the consumers towards mobile phone usage and to compare the satisfaction score among selected demographic variables. The sample size was 120 respondents. The statistical tools used in this study are Simple percentage, likert scale analysis, Rank analysis. The concept of customer satisfaction has attracted much attention in recent years. Organizations that try to analyze this concept should begin with an understanding of various customer satisfaction models. They are living in world which is totally networked with the communication. With the advent of fast technology, the world has become a global village. With the click of small buttons on a computer one can easily get any information according to user needs and choice. Recent developments in mobile technologies have produced a new kind of device, a programmable mobile phone. Generally, smart phone users can program any application which is customized for needs. Further more, they can share these applications in online market. Therefore, mobile phone and its application are now most popular keywords in mobile technology. Hence, it is vital to analyse the customer satisfaction among mobile phone users and make necessary changes in the technology in order to with stand in the competitive market. The findings state that the consumers are more satisfied with the social media facility but not satisfied with the gaming technologies of current brand of Smartphone has an influence over satisfaction. Samsung brand is mostly preferred by the respondents.

INTRODUCTION

Customer usage and buying behaviour of any product largely depend upon their perception about their product. Perception develops through how effectively product has been marketed. These day's firms are putting their best effort in marketing in order to get customer attention and positive impression on customer's mind, customer perception is also identified by the colour, shape, taste and preference of the product.

Perception is how human recognize and interpret stimuli customer satisfaction of quality is measured an essential determinant of the product choice. In other words, satisfaction is the first impression that individual draw and on the basis of its select, and interpret information to form a meaningful picture of the world. That's why it is believed that customer satisfaction influence customer level of satisfaction and so their buying and usage and decision.

The topic customer perception basically come from consumer behaviour. The purpose of this



study is to provide an overall perception of mobile phone users about their behaviour or attitude, preference and satisfaction towards mobile phones.

Customer behaviour is the study of individuals, groups, or organisation and the processes they use to select, secure, and dispose of products, services, experiences, or ideas to satisfy needs and impact that these processes have on the consumer and society. It blends elements from psychology, sociology, social anthropology and economics. It attempt to understand the decision making processes of buyers, both individuals and in groups. It studies characteristics of individual's consumers such as demographics and behaviour variables in an attempt to understand people's wants.

STATEMENT OF THE PROBLEM

Mobile phone's has now become the basic need of every person in their life. As number of manufactures has entered the Smartphone market, the competition in the Smartphone market becomes more and more fierce. Nokia a Smartphone manufacture used to dominate the phone market, but recently it appears to be losing ground in the Smartphone market. People now are living in the highly developed and technologically advanced society. For Smartphone manufactures, uncovering customer preferences and predicting customer behaviour is the key to conquer the mobile phone market. This study is conducted to know the level of satisfaction of the customers with selected respondents.

SCOPE OF THE STUDY

- The main scope of this study is to analyse the customer satisfaction towards mobile phones.
- This study helps to know the factors which influencing the consumer to purchase of mobile phone.
- This study helps to analyse the customer satisfaction level of mobile phone usage.

OBJECTIVES OF THE STUDY

- To analyse the preference level of consumers towards mobile phones among various brands of mobile phones.
- To find the satisfaction level of mobile phone users of different brands.
- To analyse the factors influencing buying behaviour of customers towards mobile phones.

RESEARCH METHODOLOGY

RESEARCH DESIGN

- **Research design**
Survey research was conducted in this study.
- **Sampling technique**
Convenient sampling technique was used.
- **Sample size**
Sample size taken study was 220 respondents.
- **Tools for analysis.**
 - Simple percentage analysis
 - Likert scale analysis
 - Rank analysis

REVIEW OF LITERATURE

Dr. L. Venkatesan, "Buyer preference towards Mobile phones in selected areas in Chennai – A study" RRDM Vol-3 Issue II November 2018. ISSN 2455 3085. The Scope of this studies the customers using Mobile Phones to find the level of their first choice, perception and satisfaction. It was collected with the aid of formal structured interview schedule, with personal face-to-face interaction. The schedule covers personal data, economic conditions, and satisfaction towards charges and services suggestions from the consumers.

Dr Sukhvir Singh and Mr Inderpreet Singh, "A study on consumer perception about smart phones" AIIRJ Vol-I January 2018 ISSN 2349 638x The mobile phone has made our life easily. We can perform different task of our daily life on mobile phones in few seconds. We can transfer money, pay utility bills by using mobile phones in few seconds for which we have to go to banks that takes a lot of time. The aim of the study is to cover entire research about judging the customer reactions while making purchase of smartphone

Revathy Rajasekaran, S. Cindhana and C. AnandhaPriya, "consumers perception and preference towards smartphone" ICTACT journal on Management studies Vol-04 Issue 3 August 2018 ISSN 2095 1664. Smartphone usage has proliferated in recent years. Nowadays people seem to become dependent towards Smartphone due to its convenience, great camera features, easy applications installations, and more importantly, it can do most of the computer functions on the go. In this technology and competitive era, this study aims to explore the key factors which motivate consumers to purchase and use Smart Phones. **Nushrat Nahida Afroz**, "Students Brand preference towards smartphone" IOSR-JBM. Vol-19 Issue-2 Feb 2017 ISSN 2278 487x. Brand preferences are usually



studied by attempting to profile and understand loyal consumers. It is the indicator of the strength of a brand in the hearts and minds of customers. Brand preference represents which brands are preferred under assumptions of equality in price, battery durability, camera resolution and so on. In recent times smart phone plays a significant role among the users to meet up their numerous objectives by operating their desired smart phone

DATA ANALYSIS AND INTERPRETATION

In this chapter the analysis and interpretation of the study on “customer satisfaction towards mobile phones” is based on the opinion of sample of 230 respondents selected from Coimbatore city through a questionnaire containing 20 questions were analysed through

- Percentage analysis
- Likert scale analysis
- Rank analysis

LIKERT SCALE ANALYSIS

TABLE SHOWING THAT MOBILE PHONES ARE MORE COMFORTABLE THAN OTHER DEVICES

S.NO	SATISFACTION LEVEL	NO.OF RESPONDENTS	LIKERT VALUE (X)	TOTAL (fx)
1	Strongly agree	76	5	380
2	Agree	82	4	328
3	Neutral	51	3	153
4	Disagree	8	2	16
5	Strongly Disagree	3	1	3
	TOTAL	220		880

(Source primary data)

fx

Likert scale = -----
Total number of respondents

$$= 880/220$$

$$= 4$$

INTERPRETATION

Likert scale value 4 is greater than the mid value 3, thus the satisfaction level of the customer is in the agree state.

TABLE SHOWING THE EXPERIENCE OF THE MOBILE PHONE

S.NO	SATISFACTION LEVEL	NO.OF RESPONDENTS	LIKERT SCALE (x)	TOTAL (fx)
1	Highly satisfied	87	5	435
2	Satisfied	86	4	344
3	Neutral	41	3	123
4	Dissatisfied	3	2	6
5	Highly Dissatisfied	3	1	3
	TOTAL	220		911

(Source primary data)



$$\text{Likert scale} = \frac{\sum fx}{\text{Total number of respondents}}$$

$$= \frac{911}{220}$$

$$= 4.140$$

Likert scale value is **4.140** which is greater than the mid value (3) thus the satisfaction level of the customer is in the agree state.

RANK ANALYSIS

TABLE SHOWING THE FEATURES OF MOBILE PHONES ACCORDING TO THEIR SATISFACTION LEVEL

S.NO	PARTICULARS	1	2	3	4	5	TOTAL	RANK
1	CAMERA	78(5)	36(4)	46(3)	39(2)	27(1)	777	1
2	STORAGE	27(5)	81(4)	59(3)	43(2)	16(1)	738	4
3	BATTERY	50(5)	43(4)	78(3)	39(2)	14(1)	748	2
4	BRAND	55(5)	43(4)	47(3)	66(2)	19(1)	739	3
5	DESIGN	49(5)	37(4)	33(3)	38(2)	67(1)	635	5

(Source primary data)

INTERPRETATION

In the above table it is understood that camera is ranked 1, Battery is ranked 2, Brand is ranked 3, Storage is ranked 4, Design is ranked 5.

In this study the majority of the respondents ranked 1 for camera and thus the influence of the camera is more in the customer behaviour.

FINDINGS

SIMPLE PERCENTAGE ANALYSIS

- Majority (51.4%) of the respondents are male.
- Majority 40.5% of the respondents are in the range of 21-30 years.
- Majority (52.7%) of the respondents are graduates.
- Majority (64.5%) of the respondents are unmarried.
- Majority (39.5%) of the respondents are students.
- Majority (33.6%) of the respondents are Rs. 2,00,000-Rs.3,00,000.
- Majority (32.7%) of the respondents use their mobile phone for 2-3 years.
- Majority (31.8%) of the respondents are using Samsung mobile.
- Majority (30.9%) of the respondents use the mobile phone for social media.

- Majority (50.9%) of the respondents buy their mobile phones through showrooms.

LIKERT SCALE ANALYSIS

- Likert scale value 4 is greater than the mid value 3, thus the satisfaction level of the customer is in the agree state.
- Likert scale value is 4.140 which is greater than the mid value (3) thus the satisfaction level of the customer is in the agree state.

RANK ANALYSIS

- In this study the majority of the respondents ranked 1 for camera and thus the influence of the camera is more in the customer behaviour.

SUGGESTIONS

- This study suggested about the customer satisfaction towards mobile phones.
- This study suggested that the mobile companies should concentrate more on facilities and innovation expected by members at the age group of 21-30
- Mostly students to prefer to buy their mobile often so the companies should improve more features regarding the students.
- Mostly the respondents are favourable to Samsung mobile, so the other brand mobile should improve to increase their scales.



- Most of the respondents records that brightness is the major factor which affects the health.

CONCLUSION

This study concluded that in this modern business economy, it is very important to analyse the satisfaction level of the customer. This study shows the majority of the customer is satisfied with the mobile phone but also there are some dissatisfaction because of various reasons if the necessary steps are taken to resolve the problem retention of customers will be high. The steps will satisfy the most of the customer and will increase in the value of sale of mobile phone. The mobile phone companies should focus on promotions, Branding and Pricing and they should give a clear picture of the product going to sell so that the customer can decide and select mobile phones. If the mobile phone companies understand and the preference and overall satisfaction of the customer and can give mobile in the price range preferred the customer with a good quality, it will bring the mobile phone industry to the next level.

REFERENCE

1. Dr. L. Venkatesan, "Buyer preference towards Mobile phones in selected areas in Chennai – A study" *RRDM Vol-3 Issue II November 2018. ISSN 2455 3085.*
2. Dr Sukhvir Singh and Mr Inderpreet Singh, " A study on consumer perception about smart phones" *AIIRJ Vol-I Jnuary 2018 ISSN 2349 638x.*
3. RevathyRajasekaran, S. Cindhana and C. AnandhaPriya, "consumers perception and preference towards smartphone" *ICTACT journal on Management studies Vol-04 Issue 3 August 2018 ISSN 2095 1664.*
4. NushratNahidaAfroz, "Students Brand preference towards smartphone" *IOSR-JBM. Vol-19 Issue-2 Feb 2017 ISSN 2278 487x.*
5. AmanjotKaur Gill, , "Youth Buying Behaviour towards Smartphones: A study in Ludhiana" *International journal of economics and management systems Vol-I 2016 ISSN 2367 8925*



A STUDY ON MARKETING PROBLEMS FACED BY COCONUT PRODUCERS WITH SPECIAL REFERENCE TO SULUR TALUK

Dr. M. Kalimuthu

*Assistant Professor, Department of Commerce with Professional Accounting,
Dr. N. G. P Arts and Science College, Coimbatore*

Dharani. S

*Student of III B.Com (PA), Department of Commerce with Professional Accounting,
Dr. N. G. P Arts and Science College, Coimbatore*

ABSTRACT

India is an agricultural country and one third depends on the agricultural sectors directly or indirectly. Coconut is one of the most useful tree in the world, and it is often referred to as the "Tree of Life". It is also called as 'Kalpavriksha'. Marketing is the best way to create a value to the product. The basic function of marketing is to attract and retain customers. Similarly coconut marketing is essential for its enormous sales. Even though the producers concentrate in marketing of coconut, they face certain problems over it. In this study an endeavor is made to find out the marketing problems faced by the coconut producers. The study would reveal the facts over the marketing problems of coconut and it may be useful to make appropriate decision over the problems in marketing of coconut.

KEYWORDS: *Coconut, Marketing problem, Channels of distribution, Price fluctuation, Farmers Association.*

INTRODUCTION

The Coconut palm is one of the most valuable plants. Coconut, the adaptable palm prevalently known as the 'Tree of Life', 'Tree of Paradise', 'Tree of Bounty', 'Lord of Palms', 'Kalpavriksha' just as 'God's Blessing to Humankind'. It is developed in excess of 80 nations of the world. Indonesia and the Philippines are the first and the second biggest coconut delivering nation on the planet. India is the third biggest coconut delivering nation having a zone of about 1.78 million hectares under the harvest. India is an agrarian nation and 33% of populace relies upon the rural part straightforwardly or in a roundabout way. Agribusiness stays as the fundamental wanderer of the Indian economy since times prehistoric. There is no palm right now, excellent than the coconut.

The Coimbatore district is one of the areas which develop measure of coconut in Tamilnadu. Further the farmers face number of issues in developing and advertising of coconut in the

examination territory. It is accounted for that the farmers couldn't ready to get satisfactory cost for the coconut in numerous events.

STATEMENT OF PROBLEM

Coconut is one of the leading commodities in agricultural exports; the production programme of the crop is of critical importance in improving the efficient use of resources. The cost of production and net return obtained per unit, would determine the profitability of the crop. Though production is the initiation of the developmental process, it could bring less gain to the producers unless there exists an efficient marketing system. Marketing is as important as production to any producer. Because it creates value to the product; it pays revenue to the producer; and more than these, it directs the producer as to whether continue or stop production. The producers depend upon the market conditions to fulfill their hopes and expectations. But lack of price stability, less government intervention and price fluctuation



due to retailers are the problems faced by the cultivators. Though coconut has a pride, not only for its diverse uses but also for its special preference to consumers, both rich and poor, it is subjected to the above stated marketing problems. Hence the present study was taken up for research purpose.

SCOPE OF THE STUDY

The present studies aims at assessing and analyzing the existing marketing practices and problems of coconut growers and examine the channels of distribution of coconuts in the study area.

It covers only the marketing of coconuts and does not go with the industrial activities involving coconuts. The study has been undertaken from the point of view of the coconut growers, and market functionaries.

OBJECTIVES OF THE STUDY

- To examine the awareness of coconut producers about the coconut market.
- To understand the marketing practices used by the coconut producers.
- To study the marketing problems faced by the coconut producers.

LIMITATIONS

- The present study is based only on the sample selected.
- The result of the analysis is fully depend on the information given by the respondents.

TOOLS FOR ANALYSIS

The primary data were coded, classified, tabulated and analysed. The statistical tools used for the analysis are:

- Simple percentage analysis
- Rank analysis

REVIEW OF LITERATURE

Dr.N.Palanivelu, G.Muthukrishnan (2019)Coconut cultivation is chiefly confined to India because of the congenial agro-climate condition of the coconut-growing region. In India coconut is mostly grown in the West and East Coast regions of the country, ie. Kerala, Tamil Nadu, Karnataka, Andhra Pradesh and Maharashtra. Tamil Nadu is considered as an important coconut producing state after Kerala, which holds the first position in terms of production and area of coconut cultivation. In Tamil Nadu, coconut is cultivated in around 410149 hectares with 58942 lakhs Nuts production. Even though the coconut production is technically and economically viable in Tamil Nadu, the cultivating area of coconut in Coimbatore which stands first among the coconut producing districts is decreasing

year by year. So it is evident that the growers of coconut in Coimbatore are giving up coconut cultivation and they are concentrating on other agricultural products. In order to highlight this problem, a study on the marketing practice with regard to coconut is to be carried out. The study would reveal the facts related to marketing cost, marketing margin, producers share, and the marketing.

Dr.S.M.Yamuna, Ms.R.Ramya(2016) India is an agricultural country and one third of population depends on the agricultural sector directly or indirectly. Agriculture remains as the main stay of the Indian economy since times immemorial. The coconut crop has a significant impact on social and cultural impact on the coconut cultivators. Marketability and price established for coconut and it by products determines the economic condition of farmers. Tamilnadu holds foremost share in coconut area and production after the state of Kerala. Coconut cultivation is considered to be one of the major livelihoods which support 60 % farmers in the state. The coconut is not only significant in socio cultural needs of our society, but also has gained considerable importance in the national economy as a potential source of rural employment and income generation among the plantation crops. . The increasing trend of coconut production has brought new challenges in terms of finding market for the surplus. There is also a need to respond to the challenges and opportunities, that the global markets offer in the liberalized trade regime. The present study has brought out the profitability involved in the cultivation and economic aspects of coconut. This study may be useful to make appropriate decision for mitigating the problems faced by coconut growers.

Vijayalakshmi N (2016) Agriculture continues to be the core sector in the rural economy of Karnataka, providing livelihood security for vast majority of the population. In the crop production sub sector. It is principal crops namely coconut that too on account of the large scale area expansion through the shift in cropping pattern. The manufacturing units procure raw materials from coconut farmers. Some local traders supplies raw materials to these manufacturing units and in returns they procure the finish products. Considering the huge production of coconut husk in the region, individual artisans and ITI graduates can be encouraged to set up their one de-timbering and yarn making units with advanced machineries. In recent years, improvements in cultivation practices and breeding have produced coconut trees that can yield more. An attempt is made in this paper to analyse the production and marketing of coconut in Tumkur area.

**DATA ANALYSIS AND INTERPRETATION**

The data collected from the samples have systematically applied and presented in tables under various headings in the following pages. They were also arranged in such a way that a detailed analysis can be made so as to present suitable interpretations for the same. The statistical tools namely simple percentage analysis and rank correlation analysis are used for interpretation of data.

FORMULA:

$$\text{Percentage} = \frac{\text{Number of respondents}}{\text{Total no. of. respondents}} \times 100$$

SIMPLE PERCENTAGE ANALYSIS

Percentage analysis is the method to represent raw streams of data as a percentage for better understanding of collected data. Percentage analysis is applied to create a contingency table from the frequency distribution and represent the collected data for better understanding. It particularly useful method of expressing the relative frequency of survey responses and other data.

Table 1**TABLE SHOWS THE RESPONDENTS WITH RESPECT TO THEIR GENDER**

S.NO	FACTORS	NO. OF RESPONDENTS	PERCENTAGE
1	Male	67	55.8%
2	Female	53	44.2%
	Total	120	100%

*(Source: Primary Data)***INTERPETATION**

It is revealed that 55.8% of the respondents are male and the 44.2% of the respondents are female

INFERENCE

Majority (55.8%) of the respondents are male.

TABLE 2**TABLE SHOWS THE RESPONDENTS WITH RESPECT TO THEIR SALES PRACTICES FOLLOWED**

S.NO	SALES PRACTICES FOLLOWED	NO. OF RESPONDENTS	PERCENTAGE
1	Wholesale	33	27
2	Retail	21	18
3	Direct to consumer	43	36
4	Mixed	23	19
	Total	120	100

*(Source: Primary Data)***INTERPRETATION**

It is revealed that 27% of the respondents are selling to the Wholesaler, 18% of the respondents are selling to the Retailer, 36% of the respondents are selling Direct to consumers and 19% of the respondents are selling as Mixed practices.

INFERENCE

Majority (36%) of the respondents are selling Direct to the consumers.



TABLE 3
TABLE SHOWS THE RESPONDENTS WITH RESPECT TO THEIR REASON FOR THE COCONUT CULTIVATION

S.NO	FACTORS	NO. OF. RESPONDENTS	PERCENTAGE
1	Source of water	26	21.7%
2	Profitability	19	15.8%
3	Less labour force	20	16.7%
4	Less maintenance	20	16.7%
5	Permanent Income	35	29.2%
	Total	120	100

(Source: Primary Data)

INTERPRETATION

It is revealed that 21.7% of the respondents reason for coconut cultivation is Source of water, 15.8% of the respondents reason for coconut cultivation is Profitability, 16.7% of the respondents reason for coconut cultivation is Less labour force, 16.7% of the respondents reason for coconut cultivation is Less maintenance and 29.2% of the respondents reason for coconut cultivation is Permanent income.

INFERENCE

Majority (29.2%) Of the respondents reason for coconut cultivation is Permanent inco

RANK CORRELATION

The Karl Pearson's method is based on the assumption that population being studied is normal or when the shape of the destruction is not known, there is need for a measure of correlation i.e. need for correlation that involves no assumption above the parameter of population. It does not matter which way the items are ranked ,item number one may be the largest or it be smallest using ranks rather than actual observation gives the coefficient rank correlation.

TABLE 4
TABLE SHOWS THE RESPONDENTS WITH RESPECT TO THEIR PROBLEMS IN COCONUT INPUT MARKETING

S.NO	FACTORS	RANK 1	RANK 2	RANK 3	RANK 4	TOTAL	RANK
1	High cost	45(4)	35(3)	29(2)	11(1)	354	1
2	Non-availability	20(4)	59(3)	34(2)	7(1)	332	2
3	Low quality	11(4)	37(3)	49(2)	23(1)	276	3
4	Durability	17(4)	24(3)	38(2)	41(1)	257	4

(Source: Primary Data)

INTERPRETATION

The above table shows that out of total 120 respondents, High cost has ranked 1st, Non-

availability has ranked 2nd, Low quality has ranked 3rd, Durability has ranked 4th.

**INFERENCE**

Majority respondents problems in coconut input marketing is High cost.

TABLE 5
TABLE SHOWS THE RESPONDENTS WITH RESPECT TO THEIR PROBLEMS IN MARKETING OF COCONUT

S.NO	FACTORS	RANK 1	RANK 2	RANK 3	RANK 4	RANK 5	RANK 6	TOTAL	RANK
1	Absence of stabilized price	46(6)	26(5)	24(4)	13(3)	7(2)	4(1)	559	1
2	Increased cost of marketing	14(6)	53(5)	28(4)	16(3)	7(2)	2(1)	525	2
3	Absence of standardization and grading	12(6)	23(5)	55(4)	13(3)	15(2)	2(1)	478	3
4	Less facilities for coconut processing	11(6)	35(5)	31(4)	22(3)	15(2)	6(1)	467	5
5	Ineffective Institutional organization	13(6)	32(5)	29(4)	16(3)	23(2)	7(1)	455	6
6	Forced sales	23(6)	33(5)	26(4)	10(3)	9(2)	19(1)	474	4

(Source: Primary Data)

INTERFERENCE

The above table shows that out of total 120 respondents, Absence of stabilized price has ranked 1st, Increased cost of marketing has ranked 2nd, Absence of standardization and grading has ranked 3rd, Forced sales has ranked 4th, Less facilities for coconut processing has ranked 5th, Ineffective Institutional organization has ranked 6th.

INFERENCE

Majority respondents problems in marketing of coconut is Absence of stabilized price.

FINDINGS, SUGGESTIONS AND CONCLUSION**FINDINGS****PERCENTAGE ANALYSIS**

- Majority (56%) of the respondents are male.
- Majority (53 %) of the respondents are at the age group of 36-50 Years.
- Majority (42%) of the respondents educational qualification is upto HSC.
- Majority (54%) of the respondents are 4-5 Members.
- Majority (42%) of the respondents Annual income are Rs 2,00,001-Rs 3,00,000.
- Majority (55%) of the respondents are Married .

- Majority (38%) of the respondents acres of cultivation is below 2-3 acres.
- Majority (29%) Of the respondents reason for coconut cultivation is Permanent income.
- Majority (92%) of the respondents are using Organic fertilizer.
- Majority (41%) of the respondents are using the technical know-how by Experience.
- Majority (36%) of the respondents are selling Direct to the consumers.
- Majority (83%) of the respondents are saying that coconut cultivation is better than other crops.
- Majority (86%) of the respondents are saying that they will extend coconut cultivation.
- Majority (53%) of the respondents suggestions to overcome the marketing problems is Farmers association.
- Majority (52%) of the respondents feels that the price offered by buyers is Average.
- In this study majority respondents ranked 1 for high cost as the problem in coconut input marketing.
- In this study majority respondents ranked 1 for absence of stabilized price as the problem in marketing coconut.



SUGGESTIONS

- The study insists heavy price fluctuation causes unexpected loss in the expected income due to retailers and middleman. Therefore middleman and retailers should be avoided.
- The study suggest to stabilize the price of the coconut and its product, the government should come forward for the implementation of price guarantee scheme.
- This study suggest that coconut cultivation is better than cultivation of other crops.
- The study suggests that the development of Farmers association of coconut for further improvement in marketing of coconut.
- The study suggests that the government could provide warehouse facilities in their nearest area for storing coconut and they could also provide subsidies for unexpected losses.

CONCLUSION

The study is based on the marketing problems of coconut faced by coconut producers. The study results about majority of producers are willing to extent their coconut cultivation but there is also a drawback such as unexpected losses, lack of price fluctuations. The study was conduct through surveys, collected many informations regarding my study and analysis where made for the responses given by the respondents. It also conclude that improvement over farmers association and government intervention is also important for solving the marketing problems faced by coconut producers.

REFERENCE

1. Dr.N.Palanivelu, G.Muthukrishnan (2019) *Problems Of Coconut Marketing In Tamilnadu, Journal of the GUJARAT Research Society,ISSN: 0374-8588 Volume 21 Issue 10, November2019.*
2. Dr.S.M.Yamuna, Ms.R.Ramya(2016) *A Study Of Coconut Cultivation And Marketing In PollachiTaluk, International Journal of Innovative Research in Management Studies (IJIRMS) ISSN (Online): 2455-7188 Volume 1 | Issue 2 | March 2016.*
3. Vijayalakshmi N (2016) *Coconut farming and marketing with special reference Totumkur District-Karnataka State. International Journal of Multidisciplinary Research and Development Online ISSN: 2349-4182, ISSN: 2349-5979, Volume 3; Issue 9; September 2016; Page No. 156-159.*



A STUDY ON CUSTOMER'S SATISFACTION TOWARDS ONEPLUS MOBILES WITH SPECIAL REFERENCE TO COIMBATORE CITY

S. Muruganatham

*Assistant Professor, Department of Commerce with Professional Accounting,
Dr. N.G.P Arts and Science College, Coimbatore*

Sangeetha. R

*Student of III B. Com (PA), Department of Commerce with Professional Accounting,
Dr. N.G.P Arts and Science College, Coimbatore*

ABSTRACT

In the course of recent years, portable showcasing has produced an expanding enthusiasm among scholastics and experts. Prior PDA industry is basically occupied with the assembling of cell phones, including cell phone handsets. Be that as it may, presently industry is completely focused on pushing ahead mechanically. One or more versatile is among scarcely any PDA makers which is situating its image exceptionally high in the brain of clients. One or more was propelled its first versatile in 2014 and in a little term of time it got one of the market chiefs in 2017, One or more leads the exceptional telephone showcase in India with 48 percent share in the Q4,2017 according to IDC. A customers sets a casing of inclinations in his/her brain to pick or buy an item or administration of same or various brands or makers. The exploration paper plots subjective examination on clients fulfillment of One or more portable dependent on the information of the clients.

KEYWORDS: *Innovation, Smartphones, Customers preference, Technical features.*

INTRODUCTION

In the course of recent years, portable showcasing has produced an expanding enthusiasm among scholastics and experts. Prior PDA industry is basically occupied with the assembling of cell phones, including cell phone handsets. Be that as it may, presently industry is completely focused on pushing ahead mechanically. One or more versatile is among scarcely any PDA makers which is situating its image exceptionally high in the brain of clients. One or more was propelled its first versatile in 2014 and in a little term of time it got one of the market chiefs in 2017, One or more leads the exceptional telephone showcase in India with 48 percent share in the Q4,2017 according to IDC. A customers sets a casing of inclinations in his/her brain to pick or buy an item or administration of same or various brands or makers. The exploration paper plots subjective examination on clients fulfillment of One or more portable dependent on the information of the clients.

STATEMENT OF PROBLEM

One plus mobile plays a brand positioning in the sector is tough task. One plus mobile may increase the online selling. The Indian mobile handset market posted revenue of 3694crores in the financial year 2013. One plus mobile cannot reaches all people, only the rich people can afford it. The major problem in one plus mobile is less innovative per year only two variants are available. This survey is help to bring more innovative and technique and also to measure the customers satisfaction.

SCOPE OF STUDY

The main aim is to examine the different factor influencing the customers towards One plus mobile. This help to understand the literacy level of customers who purchase One plus mobile. It helps to know the customers satisfaction level of One plus mobile.

**OBJECTIVES OF THE STUDY**

- To identify the factor influencing customer to buy one plus mobile phone.
- To know the level of satisfaction in one plus mobile phone.
- To identify the problems faced by the customer of one plus mobile.

TOOLS FOR ANALYSIS

- Simple Percentage Analysis
- Likert Scale Analysis
- Ranking Scale Analysis

LIMITATIONS OF THE STUDY

- The present study is based only on the sample selected.
- The result of the analysis in the study are fully depend on the information given by the respondents only.
- The data was collected from the mobile users of Coimbatore City. So, the findings of the study may not be considered for other districts.

REVIEW OF LITERATURE

RevathyRajasekaran, S. Cindhana and C. Anandha Priya Department (2018) Smartphone usage has proliferated in recent years. Nowadays people seem to become dependent towards Smartphone due to its convenience, great camera features, easy applications installations, and more importantly, it can do most of the computer functions on the go.

FORMULA

Number of respondents

Percentage = _____ x 100

Total no. of respondents

Gaurav Verma, Dr. Binod Sinha (2018) The telecommunication industry is fastest growing sector in today's economy. Earlier cell phone industry is primarily engaged in the manufacturing of mobile phones, including mobile phone handsets.

PARVEEN KUMRAIL, SATINDER KUMAR(2004) A consumer sets a frame of preferences in his/her mind to choose or purchase a product or service of same or different brands or producers.

DATA ANALYSIS AND INTERPRETATION

In this chapter the analysis and interpretation of "A study on customer's satisfaction Towards one plus mobile phones with special reference to Coimbatore city", is presented based on the opinion of samples of 120 respondents selected from Coimbatore city through a questionnaire containing 22 questions. These were analysed through three different tools and they are as follows,

- Simple Percentage analysis
- Rank Correlation
- Likert scale Analysis

SIMPLE PERCENTAGE ANALYSIS

Simple percentage analysis is the method to represent raw streams of data as a percentage for better understanding of collected data. Percentage analysis is applied to create a contingency table from the frequency distribution and represent the collected data for better understanding.

TABLE NO 4.1

TABLE SHOWING GENDER OF THE RESPONDENTS

S.NO	PARTICULARS	NO. OF RESPONDENTS	PERCENTAGE
1	Male	68	56.7%
2	Female	52	43.3%
	Total	120	100

(Source : Primary Data)

INTERPRETATION

It is revealed that 43.3% of the respondents are Female and the 56.7% of the respondents are Male.

INFERENCE

Majority 56.7% of the respondents are Male.

**RANK CORRELATION**

A rank analysis is any of several statistics that measure an ordinal association, the relationship between ranking of different ordinal variables or different ranking of the same variables, where a "ranking" is the assignment of the labels "first", "second", "third", etc., To different observation of a

particular variable. A rank analysis measures of similarity between two rankings, and can be used to assess the significance of the relation between them. It is not necessarily a total order of object because two different objects can have the same ranking. The ranking themselves are totally ordered.

TABLE NO 4.2**TABLE SHOWING THE RESPONDANCE AGREENESS LEVEL OVER THE UNIQUE OF ONEPLUS MOBILE PHON**

S.NO	PARTICULARS	RANK 1	RANK 2	RANK 3	RANK4	RANK5	RANK6	TOTAL	RANK
1	Price	30(6)	17(5)	18(4)	22(3)	13(2)	20(1)	449	3
2	Speed	6(6)	38(5)	32(4)	16(3)	15(2)	3(1)	435	4
3	Storage	25(6)	19(5)	25(4)	26(3)	11(2)	14(1)	459	2
4	Processor	12(6)	14(5)	28(4)	34(3)	21(2)	11(1)	409	5
5	Thickness	11(6)	26(5)	22(4)	17(3)	20(2)	24(1)	399	6
6	Camera	41(6)	17(5)	16(4)	16(3)	8(2)	22(1)	481	1

(Source: Primary Data)

INTERPRETATION

The above table shows that out of 120 respondents, Camera has ranked 1st, Storage has ranked 2nd, Price has ranked 3rd, Speed has ranked 4th, Processor has ranked 5th, Thickness has ranked 6th.

INFERENCE

Majority respondents are satisfied with the Camera of Oneplus Mobile phones.

FORMULA

$$\text{Likert scale} = \frac{\sum fx}{\text{Total number of respondents}}$$

Where,

F = Number of respondents

X = Likert scale value

$\sum fx$ = Total score

Mid value,

Mid-value indicates the middle most value of the Likert scale.

LIKERT SCALE ANALYSIS

Likert scales are the most broadly used method for scaling responses in research studies. Research questions that ask you to indicate your level of agreement, from strongly agree or highly satisfied to strongly disagree or highly dissatisfied, use the likert scale. In Likert scale method, a person's attitude is measured by combining (additional or averaging) their responses across all items.



TABLE NO 4.3
TABLE SHOWING THE RESPONDANCE WITH RESPECT TO THE WAY OF PURCHASE OF ONEPLUS
MOBILE PHONES THROUGH ONLINE

S.NO	FACTORS	NO.OF. RSPONDENTS (F)	LIKERT SCALE (X)	TOTAL (FX)
1	SATISFIED	75	3	225
2	NEUTRAL	35	2	70
3	DISSATISFIED	10	1	10
	TOTAL	120		305

(Source: Primary Data)

$$\begin{aligned} \text{LIKERT VALUE} &= \sum fx / \text{No.of.Respondents} \\ &= 305/120 \\ &= 2.54 \end{aligned}$$

INTERPRETATION

Likert scale value is 2.54 which is greater than the mid value (2), so the respondents are satisfied with the Online shopping of the mobile phone.

FINDINGS, SUGGESTIONS AND CONCLUSION

FINDINGS

- Majority 56.7% of the respondents are Male.
- Majority 37.5% of the respondents are 21 – 30 years.
- Majority 47.5% of the respondents are under graduates.
- Majority 58.3% of the respondent are unmarried.
- Majority 39.2% of the respondents are students.
- Majority 30.8% of the respondents are earning Rs 2,00,001 – Rs 4,00,000.
- Majority 56.7% of the respondents are from nuclear family.
- Majority 39.2% of the respondents are from urban areas.
- Majority of 35.0% of the respondents are known through friends.
- Majority of 55.0% of the respondents purchase through online shopping.
- Majority of 29.3% of the respondents are using from Rs 27000- Rs 36000.
- Majority of 36.7% of the respondents are using for 1-2 years.
- Majority 47.5% of the respondents' preference over oneplus mobile phone is Quality.
- Majority 33.3% of the respondents' major use in their mobile phone is Phone calls.

- Majority 57.5% of the respondents are not satisfied with the rate of Oneplus mobile phones.
- Majority 53.3% of the respondents agree that Oneplus mobile is unique compared to other mobiles.
- Respondents are ranked 1 for Camera as a unique feature of oneplus mobile phones.
- Likert scale value is 2.32 which is higher than the mid value (2), so the respondents are satisfied with the fingerprint of the one plus mobile phones.
- Likert scale value is 2.14 which is slightly higher than the mid value (2), so the respondents are neutral over the after sales of the one plus mobile phone.

SUGGESTIONS

- This study suggested about the customers satisfaction level of one plus mobile.
- Most of the respondents came to know about the one plus mobile through friends, so the advertising can be improved.
- The study suggested that the oneplus mobile phones can be sold in retail shops.
- Only rich people can afford a oneplus mobile, if the price reduces, the sales of the one plus mobile can be increased.
- The study suggested that the models of the mobile phone can be further improved.

CONCLUSION

The study concluded that in this modern business economy. It is very important to analyse about the oneplus mobiles. The study result about the majority of the customers are satisfied with the oneplus mobile but also there is a drawback such as hike in price and other factors like models of the product. Necessary steps have to be taken to resolve



problems of retaining customers of one plus mobiles will be high, if the company can understand the preference and overall perception of the consumer. Hence it will develop the marketing strategy and market share of oneplus mobile phone company.

REFERENCE

1. Revathy Rajasekaran, S. Cindhana and C. Anandha Priya (2018) *Consumer perception and preference towards smartphone*.ISSN: 2395-1664 (ONLINE) *ICTACT JOURNAL ON MANAGEMENT STUDIES*, AUGUST 2018, VOLUME: 04, ISSUE: 03
2. Gaurav Verma, Dr. Binod Sinha *A study on brand positioning of one plus mobiles*.Volume 5, Issue 4, July August 2018, pp. 166–170, Article ID: JOM_05_04_018ISSN Print: 2347-3940 and ISSN Online: 2347-3959
3. Parveen Kumari, Satinder Kumar *Consumer Brand Preference towards Mobile Phone: Effect of Mobile Phone Attributes on Purchase Decision*.



A STUDY ON FACTORS INFLUENCING USABILITY OF REFRIGERATOR WITH SPECIAL REFERENCE TO COIMBATORE DISTRICT

Dr. M. Kalimuthu

*Assistant Professor, Department of Commerce with Professional Accounting,
Dr.N.G.P Arts and Science College, Coimbatore*

Monisha.A

*Student of III B.Com.(PA), Department of Commerce with Professional Accounting,
Dr.N.G.P Arts and Science College, Coimbatore*

ABSTRACT

Shopper purchasing conduct has become a fundamental piece of vital market arranging. What we purchase, how we purchase, where and when we purchase, in how much amount we purchase relies upon our discernment, self-idea, social and social foundation and our age and family cycle, our mentalities, convictions esteems, inspiration, character, social class and numerous different variables that are both interior and outside and outer to us. Shopper demeanor likewise considered dependent on need, data search, development of options, buy choice and buy conduct. The acquisition of fridges is presently a typical marvel among working class and the shopper is overwhelmed with different models with fine highlights and new brands. Individuals are in the buyer advertise where the advertisers don't simply fulfill a need however attempt to accomplish purchaser amuse. In this examination, we have done the review of the purchasing conduct and inclinations of the customers in the Home apparatuses market of Haier, which are utilized by individuals all things considered.

KEYWORDS: *Innovation, Refrigerators, Consumer Preference, Motivation.*

INTRODUCTION

All advertising begins with the client. Client conduct is the examination of system that individuals or social events involvement with choosing their purchasing choice to satisfy their necessities. Ordinarily the buying decision takes, various structures in choosing their getting choices that can change dependent upon the extensive course of action of components, for instance, picking up, socio financial matters, social and social components. The purchaser contraptions adventures has building up every day and saw a remarkable advancement over the span of ongoing years. A cooler (conversationally fridge or refrigerator freeze in the UK) is a standard nuclear family machine that involves a thermally secured compartment and a glow siphon (mechanical, electronic or intensify) that moves heat from inside the refrigerator to its outside condition so that inside the refrigerator is cooled to the temperature

underneath the encompassing temperature of the room. The ice chest allows the front line nuclear family to keep sustenance fresh for longer than before Freezers license people to buy sustenance in mass and eat it at entertainment, and mass purchase put aside money.

STATEMENT OF THE PROBLEM

This study proposes to investigate several problems faced by the consumer who are using Electronic product (refrigerator). In a fast moving world refrigerator plays a vital role in every household. The new innovations made in refrigerator are becoming difficult to the consumers. They are finding some difficulties to use the product. This study is to identify the usability and adoptability of electronic product (refrigerator).



SCOPE OF THE STUDY

- The present study aims at influencing the consumers adoptability over refrigerators. It also includes the consumers way of usability over the refrigerators.
- It covers only the adoptability and usability of refrigerator and does not go with any other technical process. The study has been only taken from the point of view of the refrigerator users.

OBJECTIVES OF THE STUDY

- To find the factors influencing usability of refrigerator.
- To study the problem faced by consumer over the usage of refrigerator.
- To convey some suggestions for the problems faced by the consumer over the usability of refrigerator.

TOOLS FOR ANALYSIS

- Simple Percentage Analysis
- Likert Scale Analysis
- Ranking Scale Analysis

LIMITATIONS OF THE STUDY

- The respondents were limited and cannot be treated as a whole population
- The respondents may be biased.
- The accuracy of indications given by the respondents may not be considered adequate.

REVIEW OF LITERATURE

K. Alex and A. Maria Selvi (2016) studied an attempt at understanding the roles played by family members and the social influences in purchase of consumer durables viz., Refrigerator, Washing machine and Air conditioner. It studies if there are

FORMULA

$$\text{Percentage} = \frac{\text{Number of respondents}}{\text{Total no. of respondents}} \times 100$$

variations in product in the family buying roles and also identifies dealers understanding of these roles and social influences.

Ashish Kumar and Poonam Gupta (2015) Focused the Consumer Durables Industry consists of durable goods and appliances for domestic use such as televisions, refrigerators, air conditioners and washing machines.

S. VijayalaxmiDr.T.Srinivasa Rao (2015) Investigated a study of consumer buying behaviour for electronic product a study of select items day by day with growing needs and importance, the buying behaviour of consumer is changing rapidly, In the overall population, in this study, we divided the consumer groups in to three categories based on significant growth in recent years.

DATA ANALYSIS AND INTERPRETATION

In this chapter the analysis and interpretation of “A study on customer’s satisfaction Towards one plus mobile phones with special reference to Coimbatore city”, is presented based on the opinion of samples of 120 respondents selected from Coimbatore city through a questionnaire containing 22 questions. These were analysed through three different tools and they are as follows,

- Simple Percentage analysis
- Rank Correlation
- Likert scale Analysis

SIMPLE PERCENTAGE ANALYSIS

Simple percentage analysis is the method to represent raw streams of data as a percentage for better understanding of collected data. Percentage analysis is applied to create a contingency table from the frequency distribution and represent the collected data for better understanding.



Table 1
TABLE SHOWING GENDER OF THE RESPONDENTS

S.NO	PARTICULARS	NO OF RESPONDENTS	PERCENTAGE
1	Male	45	37.5%
2	Female	75	62.5%
	Total	120	100%

(Source: Primary Data)

INTERPETATION

It is revealed that 37.5% of the respondents are male and the 62.5% of the respondents are female

INFERENCE

Majority (62.5%) of the respondents are female.

RANK CORRELATION

A rank analysis is any of several statistics that measure an ordinal association, the relationship

between ranking of different ordinal variables or different ranking of the same variables, where a “ranking” is the assignment of the labels “first”, “second”, “third”, etc., To different observation of a particular variable. A rank analysis measures of similarity between two rankings, and can be used to assess the significance of the relation between them. It is not necessarily a total order of object because two different objects can have the same ranking. The ranking themselves are totally ordered.

TABLE 2
TABLE SHOWS THE RESPONDENTS WITH RESPECT TO THEIR SATISFACTION LEVEL OVER THE FACTORS OF THE REFRIGERATOR

S.NO	FACTORS	RANK 1	RANK 2	RANK 3	RANK 4	TOTAL	RANK
1	Price	19(4)	15(3)	44(2)	43(1)	252	4
2	Quality	23(4)	41(3)	41(2)	15(1)	312	1
3	Brand	22(4)	33(3)	43(2)	22(1)	295	2
4	Service	19(4)	33(3)	35(2)	34(1)	279	3

(Source: Primary Data)

INTERPRETATION

The above table shows that out of 120 respondents, Quality has ranked 1st, Brand has ranked 2nd, Service has ranked 3rd, Price has ranked 4th.

INFERENCE

Majority respondents are satisfied with quality of the refrigerator.

LIKERT SCALE ANALYSIS

Likert scales are the most broadly used method for scaling responses in research studies. Research questions that ask you to indicate your level of agreement, from strongly agree or highly satisfied to strongly disagree or highly dissatisfied, use the likert scale. In Likert scale method, a person’s attitude is measured by combining (additional or averaging) their responses across all items.

FORMULA

$$\text{Likert scale} = \frac{\sum fx}{\text{Total number of respondents}}$$

Where,

F = Number of respondents

X = Likert scale value

$\sum fx$ = Total score

Mid value,

Mid-value indicates the middle most value of the Likert scale.



TABLE 3
TABLE SHOWS THE RESPONDENTS WITH RESPECT TO THEIR SATISFACTION LEVEL OF QUALITY OF THE REFRIGERATOR

S.NO	FACTORS	NO. OF RESPONDENTS (F)	LIKERT SCALE (X)	TOTAL (FX)
1	SATISFIED	71	3	213
2	NEUTRAL	34	2	68
3	DISSATISFIED	15	1	15
	TOTAL	120		296

(Source: Primary Data)

$$\begin{aligned} \text{Likert Value} &= \sum fx / \text{No. of respondents} \\ &= 296/120 \\ &= 2.46 \end{aligned}$$

INTERPRETATION

Likert scale value is 2.46 which is greater than the mid value (2),so the respondent are satisfied with the Quality of the refrigerator.

FINDINGS, SUGGESTIONS AND CONCLUSION

FINDINGS

- Majority (62%) of the respondents are female
- Majority (43%) of the respondents are at the age group of 21-35
- Majority (51%) of the respondents are Undergraduate.
- Majority (27%) of the respondents are Private employee.
- Majority (67%) of the respondents are Married .
- Majority (49%) of the respondents are 4-7 Members
- Majority (40%) of the respondents family annual income is Rs. 2,00,001-Rs. 3,00,000.
- Majority (57%) of the respondents are from Rural Area.
- Majority (47%) of the respondents are using their refrigerator for 3-5 years.
- Majority (43%) of the respondents refrigerator capacity is 100-200 litres.
- Majority (75%) of the respondents are saying that they are using stabilizer.
- Majority (43%) of the respondents are buying their refrigerator from Multi brand showroom.
- Majority (46%) of the respondents are saying that New models are the motivating factors to buy.
- Majority (23%) of the respondents says that service quality is Excellent.
- In this study majority respondents ranked 1 for the quality of the refrigerator

- Likert scale value is 2.46 which is greater than the mid value (2),so the respondent are satisfied with the Quality of the refrigerator.
- Likert scale value is 2.10 which is slightly greater than the mid value (2),so the respondent are neutral over the Price of the refrigerator.
- Likert scale value is 2.09 which is slightly greater than the mid value (2),so the respondent are neutral over the Discount given to the refrigerator.
- Likert scale value is 2.28 which is greater than the mid value (2),so the respondent are satisfied with the Features of the refrigerator.
- Likert scale value is 2.06 which is slightly greater than the mid value (2),so the respondent are neutral over the updations of the refrigerator.

SUGGESTION

- Most of the respondents have bought the refrigerator for the Brand image but it is not correct to buy a refrigerator only seeing the Brand image other that brand image there are many things like capacity of the refrigerator, quality, new innovations etc are also be considered for buying a refrigerator,
- Majority of the respondents have the capacity of 100 - 200 litres in their house but the world has innovated a lot, there are many new innovations and capacity of the refrigerator are more.
- The refrigerator companies have to improve their after sales service which helps to satisfy the customers in a better way.

CONCLUSION

The study is based on usability of refrigerator. Respondents are feeling easy to adopt to



the procedures and they are feeling satisfied with the quality, price, discount, features, innovation and brand of the refrigerator. Most of the respondents are motivated by new models to buy the refrigerator and most of the respondents are buying the refrigerator for the Brand Image. The study was conducted through surveys, collected many information's regarding my study and analysis were made for the Responses given by the respondents. It is also concluded that the refrigerator is an important electronic goods which are to be bought by the consumer now-a-days and the public are feeling easy to adopt to the procedures of the refrigerator and it is easy to use the product even for an illiterate.

REFERENCE

1. K. Alex and A. Maria Selvi (2016) *A study buying decision of consumers towards white goods in Trichy city.*
2. Ashish Kumar and Poonam Gupta (2015) *To analysis consumer buying behaviour and preferences in the home appliances market of haier.*
3. S. Vijayalaxmi Dr.T.Srinivasa Rao (2015) *Consumer buying behaviour for electronic products a study of select items.*



A STUDY ON CUSTOMER SATISFACTION TOWARDS MRF TYRES (WITH SPECIAL REFERENCE TO COIMBATORE CITY)

Dr.S.Suguna

*Associate Professor, Department of Commerce with Professional Accounting,
Dr. N.G.P Arts & Science College, Coimbatore.*

Saranya.B

*Student of III B.Com.(PA), Department of Commerce with Professional Accounting,
Dr. N.G.P Arts & Science College, Coimbatore.*

ABSTRACT

This project report is the result of customer behavior of MRF tyres in Coimbatore. The objective of the study to find out the behavior of customer towards MRF tyres in Coimbatore, and offer some valuable suggestion on the basis of the study. This study has covered the consumer of MRF tyres. The research design adopted for this study was descriptive research design. The sample size is 120. the sampling technique used for this purpose was simple random sampling. For conducting survey a questionnaire was prepared. for this study purpose two types of data were collected, the data collected through questionnaire forms the primary data, the data collected journals, website and records of the forms this secondary data. The data so collected is then classified and tabulated for the purpose of analysis and then percentage analysis was used as statistical tools for analysis purpose.

KEYWORDS: Brand, Customer, Market, Preference, Satisfaction.

INTRODUCTION

Customer satisfaction means “The utility which customer expect from the product” and when a customer get expected utilities it’s called as customer satisfaction.

The main object of every organization is to earn more profit, to achieve this object the organization should increase its sales by getting more customer and the only way to get more customer is that the organization should provide expected satisfaction to the customers.

The customer market is the some total of all the goods and service purchased in a given period by all the inhabitance of a given country or a section for the satisfaction of their consumption needs. The customer market actually consists of four components like People, Purchasing Power, needs for a specific

product and willing to fill the needs with a given product.

STATEMENT OF THE PROBLEM

Profit earning has become one of the important objectives of each and every company. It is very easy to attract new customers but retaining old customer is too difficult only the satisfied customer will remain loyal to the firm brands.

A person enters a showroom when he wants to purchase tyres, but before purchasing tyres he consults so many persons about tyre.Like about price, quality, service etc., and then he make decision to purchase.

SCOPE OF THE STUDY

The study focuses of how and why customers make decision to goods and services, customer



behaviour research goes for beyond these facets of customer behaviour and considers the uses customer their sub sequent evaluations.

This record is used to find out the satisfaction level of customer towards the service and attitude given in MRF Tyres. This study is to identify the facilities provided to the customer.

OBJECTIVES OF THE STUDY

A Customer is not depend on us we are dependent on Customer, this statement is basis thing for every firm or service sector.

- To know the attributes which creates customer satisfaction among MRF tyre user.
- To know the customer behaviour towards MRF Tyres.
- To know the brand preference and the satisfaction level.
- To identify the factors influencing the purchase of MRF Tyres.
- To know the satisfaction level towards dealer service.
- To offer suggestion for further improvement.

RESEARCH METHODOLOGY

A research design is purely and simply the framework or plan for study that guides the collection and analysis of the date. In customer surveys, we have adopted this descriptive research design in collection and analysis. The data was collected from 120 respondents from Coimbatore city through questionnaire. Chi-Square analysis, Weighted average analysis, Ranking analysis were used to analyses the data.

LIMITATIONS OF THE STUDY

- The research was conducted within a limited duration. So, detailed and comprehensive study could not be made.
- Level or response is low because of fear and illiteracy of Respondents.
- Due to time and cost constraint the sample size selected is 120.
- The selected sample size is small as compared to the total number of customers. Hence the obtained result may not be accurate as it may not represent the whole population.
- Due to respondents busy schedules, the interests shown by respondents to answer the questionnaire may be less. This may have resulted in collecting inaccurate information.

REVIEW OF LITERATURE

- **Parasuraman, zenithal and Berry (Leonard L)** between 1985 and 1988 Provides the basis for the measurement of customer satisfaction with a service by using the gap between the customers expectation of performance and their perceived experience of performance. This provides the measurer with a satisfaction 'gap' which is objective and quantitative in nature.
- **A.Natarajan1, T.Sivasakthi2 and P.Muniyasamy3 (2016)** A study on customer behaviour towards MRF tyres at chengam. This project report is the result of customer behavior of MRF tyres in Chengam. The objective of the study to find out the behavior of customer towards MRF tyres in Chengam, and offer some valuable suggestion on the basis of the study.

RESEARCH METHODOLOGY

A research design is purely and simply the framework or plan for study that guides the collection and analysis of the date. In customer surveys, we have adopted this descriptive research design in collection and analysis.

RESEARCH DESIGN

A research design is purely and simply the firm work or plan for study that guides the collection and analysis of the data.

DESCRIPTIVE RESEARCH DESIGN

Descriptive research design is none that simply describes something such demographic characteristics of customer. Who use products that descriptive study is typically concerned with determining the frequency with which something occur. This study is typically guided by an initial hypothesis.

For example, and investigation of trends in consumption of factors with respect to socio-economic characteristics such as age, sex, occupation, income.

SAMPLE SIZE

The study based only on the Behaviour of customer. Total number of sample taken for the study is 120 respondents.

LOCATION OF THE STUDY

The location of the study is in Coimbatore town.



SAMPLE DESIGN

Convenience sampling techniques were used for the study.

TYPES OF DATA

- Primary data
- Secondary data

The nature of data collected for study are primary and secondary data. Primary data are those which are collected as first-hand information. Secondary are those which are collected from magazines, books, newspaper. etc.,

PRIMARY DATA

Data observed or collected directly from first-hand experience. It is collected through questionnaires.

SECONDARY DATA

Secondary data include those data, which are collection from some earlier research work and are applicable to the study the researcher has presently undertaken.

TOOLS USED FOR DATA COLLECTION

Total undesigned research, analysis data and drawing conclusion most research studies result in large volume of raw data, which must be suitably questionnaire is used as data collected too. A questionnaire consists of a set of question presented to respondents for the answer to be filled by them. A structural non-disguised questionnaire is adopted of this study.

TECHNIQUES USED FOR DATA ANALYSIS

The role of statistics in research is to function as so that the same can be read easily and can be used for further analysis. Percentage (%). The data are reduced standard from with the base equal to 100.

CHI-SQUARE

The quantity χ^2 describes the magnitude of discrepancy between theory and observation (ie) it can be known whether a given discrepancy between theory and observation can be attributed, to change or whether it results from the inadequacy of the theory to fix the observed facts.

The greater value of χ^2 the greater would be the discrepancy between observed and expected

frequencies. The formula for computing chi-square test is,

$$\chi^2 = \sum (O-E)^2/E$$

Where

O - Observed frequency

E - Expected frequency

The calculated value of χ^2 is compared with the table value of χ^2 for given degree of freedom at specific level of significance it is accepted when the calculated value is lesser than tabulated value and rejected when the calculated value is greater than the table value.

WEIGHTED AVERAGE

Weighted average is a mean calculated by giving values in a data set more influence according to some attribute of the data. It is an average in which each quantity to be averaged is assigned a weight, and these weightings determine the relative importance of each quantity on the average. Weightings are the equivalent of having that many like items with the same value involved in the average.

RANKING METHOD

Ranking method is one of the simplest performance evaluation methods. In this method, employees are ranked from best to worst in a group. The simplicity of this method is overshadowed by the negative impact of assigning a 'worst' and a 'best' rating to an employee. Such discriminations lead to negativity within a group and have a negative impact on performance.

DATA ANALYSIS AND INTERPRETATION

This chapter deals with data analysis and interpretation of the information collected by the issue of questionnaire – cum – schedule on customer satisfaction towards the vehicle of **MRF TYRES** Special reference to Coimbatore Town. The collected information is further analysed and interpreted on different categories viz., age group, income level.

**TABLE 1: WEIGHTED AVERAGE METHOD FOR LEVEL OF SATISFACTION TOWARDS MRF TYRES**

Particulars	Highly Satisfied	Satisfied	Neutral	Dissatisfied	Highly Dissatisfied	Total Score	Mean Score
Guarantee & warrantee	40	72	15	0	0	127	410
Credit facilities	10	52	33	6	2	103	332
Time duration	0	36	39	2	0	77	248
Price of the product	20	64	27	2	1	114	368
Performance of the product	30	32	33	12	0	107	345

From the above weighted average method, it is noticed that the respondent has been given high score as (410) to guarantee and warranty.

TABLE 2: RESPONDENT'S AGE WISE REASON FOR PREFERRING

Age / Reason		Product Availability	Brand	Quality	Price	Total
Below 20 Years	Count	1	1	0	0	2
	% of Total	3.2	3.2	0	0	6.5
21-30 Years	Count	1	10	6	0	17
	% of Total	3.2	32.3	19.4	0	54.8
31-40 Years	Count	0	4	5	0	9.0
	% of Total	0	12.9	16.1	0	29.0
41-50 Years	Count	0	1	0	1	2
	% of Total	0	3.2	0	3.2	6.5
51 above years	Count	0	1	0	0	1
	% of Total	0	3.2	0	0	3.2
Total	Count	2	17	11	1	31
	% of Total	6.5	54.8	35.5	3.2	100

TABLE 3: CHI-SQUARE TEST

	Value	Df	Asymp. Sig. (2-sided)
Pearson Chi-Square	24.5	12	0.01

Significant value 0.05 is greater than P value (0.01). Here we accepting null hypothesis and rejecting alternative hypothesis. So, it is clearly

indicated that there is no significant relationship between the age and brand preference.

**TABLE 4: RESPONDENT'S INCOME WISE REASON FOR PREFERRING**

Income / Reason		Product Availability	Brand	Quality	Price	Total
Below 5000	Count	0	2	0	0	2
	% of Total	0	6.5	0	0	6.5
5001 to 10000	Count	1	3	2	0	6
	% of Total	3.2	9.7	6.5	0	19.4
10001 to 20000	Count	0	5	5	0	10
	% of Total	0	16.1	16.1	0	32.3
20001 to 30000	Count	1	1	3	0	5
	% of Total	3.2	3.2	9.7	0	16.1
Above 30000	Count	0	6	1	1	8
	% of Total	0	19.4	3.2	3.2	25.8
Total	Count	2	17	11	1	31
	% of Total	6.5	54.8	35.48387	3.2	100

TABLE 5: CHI-SQUARE TEST

	Value	Df	Asymp. Sig. (2-sided)
Pearson Chi-Square	12.42	12	0.41

Significant value 0.05 is less than P value (0.41). Here we rejecting null hypothesis and accepting

alternative hypothesis. So it is clearly indicates that there is significant relationship between the income and brand preference.

TABLE 6: RANKING METHOD

Particulars	I	II	III	IV	Total Score	Mean Score	Rank
Price	28	18	18	9	73	235	3
Brand image	20	442	14	5	81	261	2
Quality	48	27	8	6	89	287	1
Availability	28	6	22	11	67	216	4

From the above ranking method, it is noticed that the respondent has been given first rank as to quality, second rank to brand image, third price of the product and the fourth rank is to product availability.

FINDINGS

- In majority of respondents for frequency male.
- The majority of respondents age group 21 – 30 years
- The most of respondent's education Under Graduate.
- Most of respondents are married.

- The most respondent's occupation level of employee.
- In Coimbatore the Majority of respondent's monthly income having Rs.10001– 20000.
- Most respondents are come to know through the advertisements.
- Most respondents using MRF tyres from 1 to 5 years.
- Most respondents are preferring the reason is brand.
- Most respondents are satisfied about guarantee & warranty.



- Most respondents are satisfied about the credit facilities.
- Most respondents are neutral about the time duration.
- Most respondents are satisfied about the price of the tyre.
- Most respondents are neutral about the performance level.
- Customers familiar with jumbo & tvs tyres.
- Chi-square test states that there is no significant relationship between age and customer preferring
- From the Chi-square test clearly identified there is significant relationship between income and customer preferring.

SUGGESTIONS

- Some of the respondents feel that the price high. Hence it should be revised.
- Some of the respondents feel the size of the packages moderate.
- Some of respondents are feel that changes may be needed in the style of the tyres which can prolong the durability and performance
- Some of the of the respondents feel to improve the availability.
- Some of the respondents suggested reduced price.
- In future JUMBO & TVS will be competitor for MRF tyres

CONCLUSION

The study gives a detailed report on customer behaviour towards preference of MRF tyres. It is from this research is calculated that the customers are satisfied with the MRF tyres performance and special feature of the tyres. but some important have to be made in reducing the price of MRF.

As the other brands like TVS and JUMBO are familiar among the customers and these brands are available by improve promotional strategies. so MRF tyres has to come up long way to attain good position in the market.

In the market the MRF tyre's showroom should show be very vigilant in retaining existing customer and they have to adopt needed strategies to get their potential customer.

REFERENCE

1. *International Journal of Research in Engineering, Science and Management Volume-1, Issue-12, December-2018* www.ijresm.com | ISSN (Online): 2581-5792 *Company Analysis of Madras Rubber Factory (MRF) Limited.*
2. ISSN: 2455-7188 (Online) "A study on consumer behaviour towards Mrf tyres at chengam" (IJIRMS) Volume 1, Issue 11, December 2016. pp.56-60.
3. *International Journal of Marketing Studies; Vol. 9, No. 2; 2017* ISSN 1918-719X E-ISSN 1918-7203 *Published by Canadian Center of Science and Education* "The influence of culture on consumer impulsive buying behaviour", *Journal of consumer psychology.*
4. *International Journal of Science and Research (IJSR) ISSN (Online): 2319-7064 Index opernicus Value (2013): 6.14 | Impact Factor (2013): 4.438 Comparative Beta Analysis of MRF Ltd and APOLLO Tyres.*
5. *International Journal of Research in Engineering, Science and Management Volume-1, Issue-12, December-2018* www.ijresm.com | ISSN (Online): 2581-5792 *Company Analysis of Madras Rubber Factory Limited.*
6. ISBN: 978-0-76231-216-0, eISBN: 978-1-84950-347-1 ISSN: 1094-5334 *Publication date: 1 January 2005 Profitability and Risk Management in Banking.*



A COMPARATIVE STUDY ON CONSUMER SATISFACTION TOWARDS FRESH FOODS AND PACKED FOODS WITH SPECIAL REFERENCE TO TIRUPUR CITY

Mr.P.Kanagaraj

*Assistant Professor, Department of Commerce with Professional Accounting,
Dr. N.G.P Arts and Science College, Coimbatore*

P.Devika

*III - B.Com (PA), Department of Commerce with Professional Accounting,
Dr. N.G.P Arts and Science College, Coimbatore*

ABSTRACT

We chose our daily intake of food based upon a number of factors. The purpose of this essay is to compare and contrast eating fresh foods and packaged foods. The two main points of discussion are flavor and health benefits. A notable similarity between fresh foods and packaged foods is flavor. When fresh foods and packaged foods are cooked, the flavor is almost identical. For example, fresh corn and packaged corn taste the same when cooked. This is also true for fresh and packaged green beans. Almost any vegetable, whether fresh or packaged, will taste the same when cooked.

INTRODUCTION

We live in a world where the variety of food is immense. In contrast, there is a significant difference between fresh and packaged foods when it comes to health benefits. Fresh foods contain a higher amount of nutrients our bodies need to be healthy. Packaged foods lose some of the original fresh food nutrients when stored. In addition, preservatives are added to packaged foods to keep them from going bad. Fresh foods, on the other hand, have no preservatives.

While the flavor of fresh and packaged foods is not significantly different when cooked, the health benefits of fresh foods is greater than packaged foods. Undoubtedly, there are more benefits to eating fresh foods. However, it is not always possible to eat fresh foods and so packaged foods are a great alternative.

Just like a car needs good fuel & additives to run smoothly, our body needs nutritious food to keep going. It is our food that builds and nourishes our bodies and provides the essential energy to carry out our daily activities. As they say, we are what we eat. Hence, in order to maintain optimum health, it is necessary to pay special attention to our everyday diet. But given our crazy lifestyle, we are busier than ever now, and it is a struggle to make nutritious meals and snacks a part of our regular diet. And that is how we fall prey to easily available processed food.

Fresh food is food which has not been preserved and has not spoiled yet. For vegetables and fruits, this means that they have been recently harvested and treated properly postharvest; for meat, it has recently been slaughtered and butchered; for fish, it has been



recently caught or harvested and kept cold. Dairy products are fresh and will spoil quickly. Thus, fresh cheese is cheese which has not been dried or salted for aging. Soured cream may be considered "fresh". Fresh food has not been dried, smoked, salted, frozen, canned, pickled, or otherwise preserve.

STATEMENT OF THE PROBLEM

There are many reported health problems prevailing in our society. It can be said that one of the major disease causing agents is food or the deficiency of it. The two divisions: Fresh foods and Packed foods has its own merits and demerits which makes difference in the level of satisfaction of the consumers. Here it is attempted to study the satisfaction level of the consumers with which the awareness can be created.

SCOPE OF THE STUDY

- ✦ The present study aims to know the comparability of fresh foods and packed foods.
- ✦ This research focus on consumers to make them prefer the food which is healthy.
- ✦ Creating awareness on choosing fresh and packed foods.

OBJECTIVES OF THE STUDY

- ✦ To know the level of satisfaction on consuming fresh food and packed food with selected respondents in Tirupur city.
- ✦ To study the problems faced by the consumers of fresh foods and packed foods.
- ✦ To find that, according to which factors did the consumers choose their food types.

RESEARCH METHODOLOGY

SOURCES OF DATA

The study includes both primary and secondary data.

- ✦ Primary data have been collected from the targeted respondents through structured questionnaire.
- ✦ Secondary source of data have been collected from the structured sources such as Journals, Internet and websites.

AREA OF THE STUDY

Study is conducted in the Tirupur city only.

SAMPLE SIZE

The sample size taken for the study was 220.

TOOLS FOR ANALYSIS

- ✦ Simple percentage method.
- ✦ Likert scale analysis
- ✦ Rank analysis.

LIMITATIONS

- ✦ The sample size is restricted only to 220 respondents, which didn't cover the whole population.
- ✦ The sample respondents are from Tirupur city and so it doesn't applicable for other cities.

REVIEW OF LITERATURE

L.C. De, Tulipa De (2019), HEALTHY FOOD FOR HEALTHY LIFE- Nutrition depends upon food is also of utmost importance in the cure of disease. Nutrients are required for buildup and maintenance of healthy cells, tissues, glands and organs which aid in metabolic, hormonal, mental, physical or chemical activities of human body. The right kind of food is the most important single factor in the promotion of health

Tanja Schneider (2018), FOOD AND HEALTH- In many parts of the world the relationship between food and health is predominately defined by a nutritional and medical discourse today. This discourse focuses on food intake as a core determinant of individual bodily and mental health, prevention of under or overweight, and of future diseases. Sociologists and other social scientists, however, have a broader understanding of the relationship between food and health and emphasize how cultural meanings and beliefs as well as social structures and institutions such as education, media, law, politics, and economy shape food practices.

Zuzana Sedlacekova (2017), FOOD PACKAGING MATERIALS: COMPARISON OF MATERIALS USED FOR PACKAGING PURPOSES- This thesis analyses package materials used for three products: tea, chocolate and milk, which are familiar to audience and they represent typical household products purchased rather often. Modern companies do not use package only as a means of cover for the product, they developed it as a tool which enables brands to communicate with customers, it contains information not only about the content of the package itself, but about the brand.

DATA ANALYSIS AND INTERPRETATION

This chapter deals with the analysis and interpretation of the study "A comparative study on



consumer satisfaction towards fresh foods and packed foods with special reference to Tirupur city” based on the collected data. The data have been classified, tabulated and analyzed using the following statistical tools.

1. Simple percentage analysis.
2. Likert scale analysis.
3. Rank analysis.

LIKERT SCALE ANALYSIS

TABLE SHOWING SATISFACTION LEVEL IN FRESH FOODS BY RESPONDENTS

S.NO	FACTORS	NO. OF RESPONDENTS (f)	LIKERT SCALE VALUE (x)	TOTAL SCORE (f x)
1	Highly satisfied	94	5	470
2	Satisfied	102	4	408
3	Neutral	19	3	57
4	Dissatisfied	1	2	2
5	Highly dissatisfied	4	1	4
Total		220		941

(Source: Primary data)

$$\text{Likert Scale} = \frac{\sum (f x)}{\text{Total number of respondents}}$$

$$= \frac{941}{220}$$

$$= 4.27$$

INTERPRETATION: Likert scale value is 4.27 which is greater than the mid value (3). So the respondents are felt satisfied in consuming fresh foods.

TABLE SHOWING SATISFACTION LEVEL IN PACKED FOOD BY RESPONDENTS

S.NO	FACTORS	NO. OF RESPONDENTS (f)	LIKERT SCALE VALUE (x)	TOTAL SCORE (f x)
1	Highly satisfied	23	5	115
2	Satisfied	81	4	324
3	Neutral	91	3	273
4	Dissatisfied	18	2	36
5	Highly dissatisfied	7	1	7
Total		220		755

(Source: Primary data)



$$\text{Likert Scale} = \frac{\sum (f x)}{\text{Total number of respondents}}$$

$$= 755/220$$

$$= 3.43$$

INTERPRETATION: Likert scale value is 3.43 which is greater than the mid value (3). So the respondents are satisfied in consuming packed food.

RANK ANALYSIS

TABLE SHOWING THE RANKING OF SOME FACTORS IN FRESH FOODS

S.NO	FACTORS	RANK 1	RANK 2	RANK 3	RANK 4	RANK 5	TOTAL	RANK
1	Freshness	61(5)	47(4)	36(3)	48(2)	28(1)	725	4
2	Taste	52(5)	49(4)	60(3)	36(2)	23(1)	731	3
3	Time consumption	32(5)	33(4)	58(3)	41(2)	56(1)	604	5
4	Hygiene	109(5)	36(4)	29(3)	28(2)	18(1)	850	1
5	Healthy	69(5)	76(4)	30(3)	25(2)	20(1)	809	2

(Source: Primary data)

INTERPRETATION

The above table shows that out of 220 respondents, hygiene has ranked 1st, healthy has ranked

2nd, tasty has ranked 3rd, freshness has ranked 4th, and time consumption has ranked 5th.

Majority of the respondent ranked hygiene as 1st.

TABLE SHOWING THE RANKING OF SOME FACTORS OF PACKED FOODS

S.NO	FACTORS	RANK 1	RANK 2	RANK 3	RANK 4	RANK 5	TOTAL	RANK
1	Hygiene	80(5)	22(4)	38(3)	43(2)	37(1)	725	2
2	Healthy	44(5)	55(4)	54(3)	49(2)	18(1)	718	3
3	Taste	54(5)	32(4)	76(3)	43(2)	15(1)	727	1
4	Flavor	46(5)	55(4)	42(3)	63(2)	14(1)	716	4
5	Freshness	57(5)	31(4)	43(3)	39(2)	50(1)	666	5

(Source: Primary data)

INTERPRETATION

The above table shows that out of 220 respondents, taste has ranked 1st, hygiene has ranked 2nd, healthy has ranked 3rd, flavor has ranked 4th, and freshness has ranked 5th.

Majority of the respondents ranked taste as 1st.

FINDINGS

1. Simple percentage analysis

- ❖ It is found that (50%) of the respondents choose fresh food for its freshness & healthiness.
- ❖ It is found that (39.5%) of respondents buy fresh foods from super markets.



- ❖ It is found that majority (45.9%) of the respondents prefer packed foods for instant cooking facility.
- ❖ It is found that majority of the respondents prefer packed food for its taste.
- ❖ It is found that (40.5%) of the respondents see health issues as a drawback.
- ❖ It is found that majority (42.3%) of the respondents intake packed foods once in a week.
- ❖ It is found that majority (54.1%) of the respondents buy packed foods from super markets.
- ❖ It is found that (85%) of respondents prefer fresh foods over packed foods.

2. Likert scale analysis

- ❖ It is found that the respondents feel convenient to consume fresh foods.
- ❖ It is found that the respondents are satisfied in consuming fresh foods.
- ❖ It is found that the respondents feel convenient to consume packed food.
- ❖ It is found that the respondents are satisfied in consuming packed food.

3. Rank analysis

- ❖ According to the preference of fresh food, hygiene is ranked 1st.
- ❖ According to the preference of packed food, taste is ranked 1st.

SUGGESTIONS

- ❖ The first and foremost preference must be given to the health of the consumer than taste of the foods.
- ❖ Consumers should try to select harmless packed foods which are equally available like organic foods.
- ❖ The awareness of health complications that might occur when consuming packed foods must be clearly known to the consumers.

CONCLUSION

The study included various aspects through which the awareness of the general public over fresh foods and packed foods are measured. This study evaluated the satisfaction level and reasons for the preference of consumers towards fresh and packed foods. It was found that the satisfaction levels of both fresh and packed foods are more or less similar with different factors. Respondents of this study indicated that they prefer fresh food for their health and packed food for its taste. Packed foods are non-avoidable in this present generation. So, this study suggests valid recommendations to bring a healthy food habit in the

near future. Suggested measures must be implemented to develop a healthy society.

REFERENCES

1. DE, L.C. 1 AND TULIPA DE 2 -IICAR-NRC for Orchids, Pakyong, Sikkim, 2Department of Plant Pathology, UBKV, Pundibari, Cooch Behar, West Bengal, India.
2. TANJA SCHNEIDER (2018), *Food and Health*.
3. ZUZANA SEDLACEKOVÁ (2017), *Food packaging materials: Comparison of materials used for packaging purposes*.
4. GEETA ARYA (2013), *Effects of junk food & beverages on adolescent's health – A review article*.
5. BULENT EKER, AYSEL ICOZ (2016), *Packaging materials and effects on quality of life*.



A STUDY ON CUSTOMERS SATISFACTION TOWARDS HIMALAYA PRODUCTS WITH SPECIAL REFERENCE TO COIMBATORE CITY

Mr.P.Kanagaraj

*Assistant Professor, Department of Commerce with Professional Accounting
Dr.N.G.P Arts and Science College, Coimbatore*

M.Pavithra

*Student of III B.Com (PA), Department of Commerce with Professional Accounting
Dr.N.G.P Arts and Science College, Coimbatore*

ABSTRACT

Marketing requires co-ordinating, planning, implementation of campaigns and employs with the appropriate skills to ensure marketing success. Marketing objectives, goals and targets have to be monitored and met, competitor strategies analysed, anticipated and exceeded. Consumer consumes things for daily use; they also consume and buy these products according to their needs, preferences and buying power. Customer is influenced by their attitude towards the product and therefore marketers need to implement strategies and tactics frequently in order to achieve more consumers. This study highlights the satisfaction of consumers towards Himalaya products in Coimbatore city.

KEYWORDS: *Herbal product, Customer satisfaction, Ayurvedic product.*

INTRODUCTION

Customer satisfaction is a key factor in formulation of customer's desires for future purchase. Although satisfaction has been defined as the differences between expectation and performance, but there are differences between quality and satisfaction. Ayurveda or the science of life was an ancient, holistic system for diagnosis and treatment, perhaps like the oldest system of medicine known to the humanity.

At Himalaya, they have pioneered the use of modern science to rediscover and validate Ayurveda's secrets. They employ cutting edge research to create pharmaceutical-grade Ayurvedic products. Natural, effective and safe, these products have helped thousands of people live healthier, richer lives. Their focus was on wellness on helping people get healthy and stay healthy.

STATEMENT OF THE PROBLEM

Presently different varieties of products are available in the market. Each product differs from one another in terms of price, quality quantity, offers, advertisements etc. The competition is severe and the manufacturer has to consider the opinion of the consumers. Customer satisfaction in Himalaya products may depend upon numerous factors. Individual decision differs from one person to another person. A study on customer satisfaction level for various brands of Himalaya products will certainly help for further growth and development in right direction.

OBJECTIVES OF THE STUDY

- To study the socio-economic factors affecting the consumer satisfaction of Himalaya products.
- To identify the problems faced by the respondents while using Himalaya products.



- To study the reasons for selecting the particular brand.

RESEARCH METHODOLOGY

SOURCE OF DATA

- Primary data
- Secondary data

AREA OF THE STUDY

The area taken for the study was Coimbatore city.

SAMPLE SIZE

The sample size used for the study was 120.

SAMPLING TECHNIQUE

The sampling technique used for the study was purposive sampling.

TOOLS FOR ANALYSIS

- Simple percentage analysis
- Likert scale analysis
- Rank analysis

LIMITATIONS

- The study was confined only to Coimbatore city so it cannot be suitable for other places.
- Getting accurate response due to their inherent problem is difficult.

REVIEW OF LITERATURE

M.Vijay and Dr. Suresh kumar (2019) Determinants of customer satisfaction towards herbal products in selected area of Tamil Nadu states that Ayurveda or the 'Science of Life' is an ancient, holistic for diagnosis and treatment, perhaps the oldest system of medicine known to humanity. At Himalaya the research will begins with the raw herbs chosen from traditional texts, both from observations and experiences of indigenous plants. The objective is to find the current herbal products scenario in India. The result of the study will help the company to identify the satisfaction level of the customers and demand of various benefits provided and promotional activities adopted by the company.

Dr. T. Malathi and R. Sangeetha (2019) Consumption pattern of cosmetic products among

college female students, a study focus on environmental impact factors states that beauty care substances or cosmetic products can be made either natural substances or chemical compounds to enhance both odor and appearance of human body. Today people are more concerned about their self-personality and self-consciousness; hence the demand for cosmetic products is increasing rapidly. The objective is to identify the environmental impact factors the purchase of cosmetics among college female students. Consumers are generally ecstatic when they think they are getting a good deal and to motivate them to purchase to by providing offers like buy one get one free deals, buy one get one half deals, and a free gift with purchase option.

Dr. A. RadhaKrishnan and Radhika.k A study on customer satisfaction towards Himalaya Products with reference to Cuddalore Town states that customer satisfaction is defined as the number of customer, or percentage of total customers, whose exported experience with a firm, its products, or its services exceeds specified satisfaction is seen as a key differentiator and increasingly has become a key element of business strategy. The objective is to identify the problems face by the respondents while using Himalaya products. 45% of the respondents preferred to purchase the Ayurvedic products. It gives a good results to the users, because each of the Himalayas are researched and trailed by the research and development center of Himalaya company.

DATA ANALYSIS AND INTERPRETATION

In this chapter, the analysis and interpretation of "a Study on customers satisfaction towards Himalaya products with special reference to Coimbatore city" based on a sample size of 150 respondents selected from Coimbatore city through a questionnaire comprising of 20 questions. The collected data are classified and tabulated and further the following statistical measures are also employed in fulfilling the objectives of the study.

- Simple percentage analysis
- Likert scale analysis
- Rank correlation

**LIKERT SCALE ANALYSIS****TABLE SHOWING THE SATISFACTION LEVEL OF RESPONDENTS TOWARDS QUALITY OF THE PRODUCT**

Particulars	No of respondents	Likert scale value	Total score
Highly satisfied	45	5	225
Satisfied	75	4	300
Neutral	26	3	78
Dissatisfied	3	2	6
Highly dissatisfied	1	1	1
Total	150		610

*(Source: Primary data)*Likert scale = $\sum (fx) / \text{number of respondents}$

$$= 610/150$$

$$= 4.06$$

INTERPRETATION :The likert scale value is higher than the mid value (4) so the respondents are highly satisfied with the quality of the product

TABLE SHOWING THE SATISFACTION LEVEL OF THE RESPONDENTS TOWARDS PRICE OF THE PRODUCT

Particulars	No of respondents	Likert scale value	Total score (fx)
Highly satisfied	17	5	85
Satisfied	68	4	272
Neutral	58	3	174
Dissatisfied	7	2	14
Highly dissatisfied	0	1	0
Total	150		545

*(Source: Primary data)*Likert scale value = $\sum (fx) / \text{No of respondents}$

$$= 545/150$$

$$= 3.63$$

INTERPRETATION :The likert scale value is 3.63 is higher than the mid value (3) so the respondents are satisfied with the price of the product.

**RANK ANALYSIS****RANKINGS OF THE PRODUCT BY RESPONDENTS**

Particulars	Rank	1	2	3	4	5	Total score	Rank
	Score	5	4	3	2	1		
Face wash	Rank	24	58	37	23	8	493	4
	Score	96	232	111	46	8		
Shampoo	Rank	16	50	62	16	6	504	2
	Score	80	200	186	32	6		
Cosmetics	Rank	16	50	58	20	6	500	3
	Score	80	200	174	40	6		
Toothpaste	Rank	23	50	50	20	7	512	1
	Score	115	200	150	40	7		
Skincare	Rank	20	43	49	23	15	480	5
	Score	100	172	147	46	15		

(Source: primary data)

INTERPRETATION

The above table 1 shows that out of 150 respondents, toothpaste has the highest ranking i.e., ranking no 1, shampoo ranks 2, cosmetics ranks 3, face wash ranks 4, and skincare ranks 5.

Majority of the ranking was done for toothpaste.

FINDINGS**1. SIMPLE PERCENTAGE ANALYSIS**

- It is founded that majority (45.3%) of the respondents are influenced by natural ingredients.
- It is founded that majority (53.3%) of the respondents use Himalaya products monthly once.
- It is founded that majority (47.3%) of the respondents prefer general stores to buy Himalaya products.
- It is founded that majority (38%) of the respondents use face wash.
- It is founded that majority (34%) of the respondents buy this product for the purpose of moisturizing.
- It is founded that majority (46%) of the respondents does not face problem in any of the Himalaya products.
- It is founded that majority (86.7%) of the respondents will recommend this product to others.

2. LIKERT SCALE ANALYSIS

- It is found that the likert scale value 4.06 is higher than the mid value (4) so the

respondents are highly satisfied with the quality of the product.

- It is found that the likert scale value 3.63 is higher than the mid value (3) so the respondents are satisfied with the price of the product.
- It is found that the likert scale value 3.68 is higher than the mid value (3) so the respondents are satisfied with the offers of the product.
- It is found that 3.84 is higher than the mid value (3) so the respondents are satisfied with the availability of the product.
- It is found that 3.62 is higher than the mid value (3) so the respondents are satisfied with the healing of the product.

3. RANK ANALYSIS

Respondents are more satisfied with toothpaste than other products.

SUGGESTIONS

- Himalaya company should increase the availability of the products in every possible areas.
- The company should distribute magazines, house journals to the consumers to aware them about new schemes and offers.
- Himalaya company should produce products accordingly which suits all types of skin of the consumers.
- Himalaya company should focus on the price reduction of the product. Many consumers regretting this product because of high pricing.



CONCLUSION

- The Himalaya company aims to create a brand image in the mind of consumers.
- Most of the consumers generally prefer Himalaya toothpaste and shampoo.
- The company adopts mass advertising media and brand ambassador to promote their product.
- Company has introduced new facilities and services into the market.

REFERENCE

1. *M.Vijay and Dr. Suresh kumar (2019) Determinants of customer satisfaction towards herbal products in selected area of Tamil Nadu*
2. *Dr. T. Malathi and R. Sangeetha (2019) Consumption pattern of cosmetic products among college female students*
3. *Dr. A. RadhaKrishnan and Radhika.k A study on customer satisfaction towards Himalaya Products with reference to Cuddalore Town.*
4. *Ms. K. Sujatha and Ms. S. Amala (2018) A study on consumer satisfaction towards Himalaya Skincare products in Tiruchirappalli Town*
5. *Dr. Lakshmi Priya (2017) satisfaction level of customers towards Himalaya face wash products*



FORMATION OF QUALITY INDICATORS OF COTTON LINES OBTAINED BY INTERGENOMIC INTROGRESSIVE METHODS

Sh.A.Samanov¹

¹Junior Researcher, Department Systematics and Introduction of Cotton-plant, Institute of Genetics and Plant Experimental Biology under Academy of Sciences, Tashkent Region, Uzbekistan

B.Kh.Amanov²

²Department of Biology, Chirchik State Pedagogical Institute, Tashkent Region, Chirchik city, Amir Temur 111700, Uzbekistan

D.U.Zakirov³

³Department of Biology, Chirchik State Pedagogical Institute, Tashkent Region, Chirchik city, Amir Temur 111700, Uzbekistan

ABSTRACT

The article reveals the data on the positive indicators of all different genomic cotton lines in terms of fiber quality and their full correspondence to the current quality requirements for cotton fiber. One of the main reasons for this was the positive effect of cultivated and wild species involved in the origin of lines on fiber quality, the emergence of transgressive forms of introgressive plants obtained on the basis of experimental polyploidy with high fiber quality and the correct selection process, as well as, the creation of new high-fiber lines.

KEYWORDS: cotton plant, plant, genome, hybrid, line, transgressive, introgressive, fiber, micronaire, specific tensile strength, upper half mean length, sample.

INTRODUCTION

Presently, natural cotton fiber is considered as a source of raw material for light industry. Considering this, it can be said that the technological quality indicators of fiber of many new and promising varieties of cotton created in the world cotton industry play a key role. A lot of research work has been done on fiber quality indicators. In particular, in the research of B.Kh.Amanov, S.M.Rizaeva, A.A.Abdullaev [1-9], a new fine-fiber "Angor" variety was created as a result of cross-hybridization of subspecies *vitifolium* of *G.barbadense* L. species and Karshi-8 variety of cotton. In this variety, the fiber micronaire was 4.1, the specific tensile strength was 43.6 gk / tex, and

upper half mean length was 1.41 inches. In addition, a number of studies on morphological, physiological, biochemical methods in the cotton plant have been conducted [4, 5].

O.Kuchkarov [4] analyzed the characteristics and fiber quality indicators, such as micronaire, fiber length and relative tensile length of the fiber of the parent lines, F₃ hybrids and standard C-6524 variety studied in saline soils.

The CF-1, 045, 06, ИК-2, ИК-3, CF-6 and CF-7 lines have shown superiority over the standard C-6524 variety in terms of their fiber quality. It has proven that they meet the requirements of type IV in terms of fiber quality, even when grown in saline conditions. While all of the studied F₃ hybrids



showed superiority over the standard variety, the IK-3 x 045 hybrid had a fiber yield of 40.1% and a fiber length of 1.27 inches, while the CF-7 x CF-1 hybrid had a micronaire index of 3.8 and were distinguished from other lines and hybrids. The hybrids have been recommended as a primary material to improve fiber quality and to use them in selection-breeding processes.

T.D. Allambergenov [1] determined for the first time to use the variety with fiber of type IV as a paternal form in cross-breeding of medium-fiber cotton varieties, and the dominance of this variety resulted in F₁ combinations with good fiber micronaire and specific tensile strength parameters. Fiber micronaire, upper half mean length, similarity in length and inheritance of indicators of short fiber index in F₁ hybrids as a strong dominance type were proven to be the result of strong effect of allele genes in the heterozygous state, while the specific tensile strength of fiber and the inheritance of

elongation at break at different types were the result of different levels of expression of alleles.

OBJECT AND THE METHODS OF RESEARCH

Based on intergenomic introgressive forms the T-24, T-PCM, T-138, T-141 lines were obtained.

Scientific studies were performed based on the following methods: mathematical analysis and HVI in "Sifat" center.

RESEARCH RESULTS

The quality indicators of cotton fiber are analyzed using modern HVI equipment. Therefore, in our research, the quality of new lines obtained based on different genomic species was determined using HVI equipment at the Republican Center "Sifat", and the data on some fiber quality were compared with the fiber of regionalized C-6524 variety (Table 1).

Table-1
Formation of the trait on quality indicators of the lines obtained based on multi-genome species (reference of "Sifat" center, in 2017-2019).

№	Lines	Number of plants	mic (micronaire)				Relative t standard ± difference
			$\bar{x} \pm S$ \bar{x}	Limit	S	V %	
In 2017							
1	T-24	50	4,3±0,05	4,1-4,5	0,14	2,7	± -0,1
2	T-PCM	50	4,6±0,06	4,2-4,6	0,16	2,3	± +0,2
3	T-138	50	4,4±0,07	4,0-4,6	0,34	5,8	± 0,0
4	T-141	50	4,6±0,06	4,2-4,7	0,21	2,9	±+0,2
5	st. C-6524	50	4,4±0,04	4,3-4,5	0,11	2,1	
In 2018							
1	T-24	50	4,5±0,08	4,1-4,8	0,24	4,8	± 0,0
2	T-PCM	50	4,2±0,10	3,6-4,5	0,32	6,5	±-0,3
3	T-138	50	4,5±0,06	4,2-4,7	0,18	2,7	± 0,0
4	T-141	50	4,4±0,11	3,6-4,7	0,34	7,7	±-0,1
5	st. C-6524	50	4,5±0,03	4,3-4,6	0,10	2,4	
In 2019							
1	T-24	50	4,7±0,10	4,4-4,8	0,15	2,8	±+0,2
2	T-PCM	50	4,1±0,09	3,6-4,5	0,29	6,4	±-0,4
3	T-138	50	4,4±0,07	4,0-4,8	0,23	5,3	±-0,1
4	T-141	50	4,8±0,10	4,2-5,2	0,30	6,3	±+0,3
5	st. C-6524	50	4,5±0,06	4,3-4,6	0,13	2,2	

It is known that one of the most important quality indicators of fiber is micronaire (mic) that indicates the thinness and maturity of the fiber depending on the air permeability of cotton fiber sample. It should be noted that the micronaire index

may change depending on agrotechnical measures when studied comparatively during the years. In international classifications, the micronaire index is analyzed according to the following criteria and presented in most literature as the follows, i.e. the



interval between 3.7-4.2 is "premium interval", 3.5-3.6 mic and 4.3-4.9 mic interval is "main interval", if less than 3.4 mic and more than 5.0 mic, then is "deductible from the price".

In the new studied lines, the micronaire index ranged from 4.1 to 4.8 mic when analyzed at the "Sifat" center in 2017-2019. In 2017, the most positive result on this trait was found in the line T-24 (4.3 mic), which was found to meet the "main interval" criteria. The micronaire index of cotton fiber is in the range of 4.6 mic in 2 of the 4 lines, which makes 50.0% of the total lines studied. Only one T-138 line analyzed had an indicator of 4.4 mic, which was found to be equivalent to the standard C-6524 variety. The micronaire index, which is one of the qualitative characteristics of the fiber, of less than 3.4 mic and higher than 5.0 mic that meet the "deductible from the price" criteria were not recorded in different genomic lines (see Table 3.5).

According to the second and third year data, analog indicators on the micronaire index were recorded. For example, in the T-PCM line analyzed under this trait, a slight positive change was observed over the years, that is, according to the results of the

study in 2018-2019, we can see that the this line showed 4.1 mic interval of "premium interval" indicator that is superior to all lines on this trait.

The obtained data showed that the micronaire index of the analyzed lines was significantly positive than that of C-6524 in terms of micronaire index, which fully complied with the requirements for type III-IV type cotton fiber belonging to medium-fiber cotton varieties (Table 1).

In our study, the specific tensile strength (Str) - strength of cotton fiber from the fiber quality indicators was also analyzed. The strength of the fiber is expressed in the HVI Calibration Cotton in g/tex (cH /tex). In accordance with the data of 2017, the specific tensile strength trait in all analyzed lines with multi-genomes ranged from 32.1 gs /tex (T-141) to 35.4 gs/ tex (T-35.4), and the difference from the standard variety was 7.8. -11.1 gs /tex. In 2018-2019 also a positive rate was recorded in all multi-genomic lines in terms of specific breaking strength (Str). The specific tensile strength of the standard variety C-6524 was equal to 24.3-27.0 gs /tex (Table 2).

Table-2
Formation of the trait on qualitative indicators fiber of the lines obtained based on multi-genome species (Reference of "Sifat" centre, in 2017-2019).

№	Lines	Number of plants	Str (specific tensile strength) g/ tex				Relative to standard ± difference
			$\bar{x} \pm S \bar{x}$	Limit	S	V %	
In 2017							
1	T-24	50	34,6±0,33	32,8-36,1	1,04	3,02	± 10,3
2	T-PCM	50	34,0±0,43	31,2-35,6	1,37	4,02	± 9,7
3	T-138	50	35,4±0,32	33,6-37,0	1,02	2,87	± 11,1
4	T-141	50	32,1±0,16	31,3-33,1	0,51	1,59	± 7,8
5	st. C-6524	50	24,3±0,38	22,0-27,0	1,09	3,9	
In 2018							
1	T-24	50	27,6±0,38	25,2-30,0	1,09	4,9	± 0,6
2	T-PCM	50	34,6±0,45	30,0-36,0	1,23	4,3	± 7,6
3	T-138	50	32,9±0,50	29,0-36,0	1,34	4,1	± 5,9
4	T-141	50	33,3±0,30	29,0-35,0	1,31	4,8	± 6,3
5	st. C-6524	50	27,0±0,41	25,0-29,0	1,06	4,3	
In 2019							
1	T-24	50	32,1±0,43	29,8-35,4	1,35	4,20	± 5,9
2	T-PCM	50	32,9±0,33	31,5-34,5	1,05	3,20	± 6,7
3	T-138	50	30,2±0,57	27,0-32,4	1,81	6,01	± 4,0
4	T-141	50	30,6±0,62	26,5-33,1	1,95	6,36	± 4,4
5	st. C-6524	50	26,2±0,41	21,0-29,0	1,27	4,1	

It is known that another characteristics of fiber quality is **upper half mean fiber length**

(UHM). Based on the three-year data, we analyzed the upper half mean length index (2017-2019). The upper half mean length strength is a sign of the mean



length of the longest fibers, which is half the mass of the sample being determined. This indicator is calculated in inches or mm. The fiber length trait of multi-genomic lines was analyzed in laboratory conditions, and the analysis of mm parameters of this trait were presented above. The fiber length index

was determined on the HVI equipment, the degree to which the lines confirmed their indicators under laboratory conditions according to the defined trait was noted, and the data obtained were analyzed (Table 3).

Table-3
Formation of the trait on qualitative indicators fiber of the lines obtained based on multi-genome species
(Reference of "Sifat" centre, in 2017-2019).

№	Lines	Number of plants	UHML (upper half mean length) inch				Relative to standard ± difference
			$\bar{x} \pm S \bar{x}$	Limit	S	V %	
In 2017							
1	T-24	50	1,11±0,01	1,05-1,16	0,03	2,9	±-0,02
2	T-PCM	50	1,14±0,01	1,09-1,19	0,03	2,7	± 0,01
3	T-138	50	1,09±0,01	1,05-1,12	0,02	1,9	±-0,04
4	T-141	50	1,08±0,01	1,04-1,12	0,03	2,3	±-0,05
5	st. C-6524	50	1,13 ±0,01	1,09-1,16	0,02	2,1	
In 2018							
1	T-24	50	1,18±0,01	1,12-1,23	0,03	2,5	± 0,06
2	T-PCM	50	1,18±0,01	1,15-1,23	0,02	2,0	± 0,06
3	T-138	50	1,14±0,01	1,11-1,17	0,02	1,7	± 0,02
4	T-141	50	1,15±0,01	1,12-1,21	0,03	2,1	± 0,03
5	st. C-6524	50	1,12±0,02	1,08-1,17	0,03	2,3	
In 2019							
1	T-24	50	1,20±0,01	1,12-1,28	0,05	3,9	± 0,06
2	T-PCM	50	1,18±0,02	1,12-1,27	0,05	4,2	± 0,04
3	T-138	50	1,13±0,01	1,10-1,18	0,02	1,9	±-0,01
4	T-141	50	1,19±0,01	1,15-1,25	0,03	2,4	± 0,05
5	st. C-6524	50	1,14 ±0,01	1,08-1,16	0,04	2,5	

In accordance with the analysis of the results, it was noted that the indicators of multi-genome lines were significantly positive in the second and third years compared to the standard C-6524 variety, but in the data of 2017, only one T-RCM line was found to be superior to the standard variety (1.14 inches) (Table 3).

If we look at the results of 2018-2019, the best results in almost all of the studied multi-genomic lines on the upper half mean length (UHM) trait were observed in T-24 (1.18 inches), T-RCM (1.18 inches), T-138 (1.14 inches), T-141 (1.15 inches) in 2018. While in the results of 2019, T-24 (1.20 inches), T-RCM (1.18 inches), T-141 (1.19 inches) were also noted to be positive. Such results were also proved by the index of the lines analyzed. In general, the upper half mean length index was found to be significantly higher than C-6524 variety belonging to the type IV used as a standard. One of the most important indicators of cotton, the fiber length trait,

was noted to be analog to the indicator and data detected in the HVI equipment at the "Sifat" center.

CONCLUSION

Analysis of the results obtained on the quality indicators of cotton fiber shows that all indicators of different genomic lines are positive in terms of fiber quality and fully meet the current requirements for the quality of cotton fiber. One of the main reasons for this was the positive effect of cultivated and wild species involved in the origin of lines on fiber quality, the emergence of transgressive forms of introgressive plants obtained on the basis of experimental polyploidy with high fiber quality and the correct selection process, as well as, the creation of new high-fiber lines.

Research work and studies are being conducted to bring these lines analyzed comparatively to the varietal level and introduce them into production.

**REFERENCES USED**

1. Allambergenov T.D. *Inheritance and variability of "fiber quality" trait of cotton varieties belonging to G.hirsutum L. species in F₁ and F₂ hybrids // Abst.diss.doct.on biol.sci (PhD). Tashkent. 2020.- pp. 19-20.*
2. Amanov B.Kh., S.M. Rizaeva, A.A. Abdullaev. *Some farm valuable traits of fin-fiber cotton variety "Angor"// Proceedings from Science Academy of the Republic of Uzbekistan. – Tashkent, 2018. – №1.– pp. 98-100. (03.00.00; № 6).*
3. Amanov B. Kh., Muminov Kh. A. (2014). *Inheritance and variability of farm valuable traits of hybrids obtained on the basis of cross-breeding of tetraploid cotton species G. barbadense L. and G. darwinii Watt. // The Way of Science, 17.*
4. O.Kuchkarov. *Fiber quality indicators of cotton lines and F₂ hybrids studied under saline soil condition.// "Agro Ilm" journal.- Tashkent. 2019. Special issue. - pp. 5-6.*
5. Shavkiev, J., Nabiev, S., Azimov, A., KHamdullaev, S., Amanov, B., Matniyazova, H., & Nurmetov, K. (2020). *CORRELATION COEFFICIENTS BETWEEN PHYSIOLOGY, BIOCHEMISTRY, COMMON ECONOMIC TRAITS AND YIELD OF COTTON CULTIVARS UNDER FULL AND DEFICIT IRRIGATED CONDITIONS. Journal of Critical Reviews, 7(4), 131-136.*
6. Amanov, B. K., Rizaeva, S. M., Khidirov, M. T., & Umirova, L. F. (2020). *Inheritance of morphobiological signs in plants F₁-F₂ obtained based on the intrasped hybridization of the peruvian cotton household. ISJ Theoretical & Applied Science, 02 (82), 78-82.*
7. Kh, A. B. (2018). *Correlation between some morphological and economical traits at the hybrids F₄ obtained on the base of intraspecific diversity of species G. barbadense L. European science review, (7-8).*
8. Amanov, B. Kh., & Samanov, Sh. A. (2020). *INHERITANCE AND VARIABILITY OF FIBER LENGTH SIGN IN F₁-F₂ PLANTS OBTAINED BY HYBRIDIZATION OF LINE AND VARIETIES OF THE SPECIES G. BARBADENSE L. THEORY, SCHOOL AND CONCEPTS OF SUSTAINABLE DEVELOPMENT OF SCIENCE, 12.*
9. Ризаева, С. М., Аманов, Б. Х., Рафиева, Ф. У., Арсланов, Д. М., Муминов, Х. А., & Саманов, Ш. А. (2014). *ПОКАЗАТЕЛИ ХОЗЯЙСТВЕННЫХ ПРИЗНАКОВ ЛИНИЙ ХЛОПЧАТНИКА, ПОЛУЧЕННЫХ НА ОСНОВЕ МЕЖВИДОВОЙ (G. HIRSUTUM L. x (G. THURBERI TOD. x G. RAIMONDII ULB.)) ГИБРИДИЗАЦИИ. The Way of Science, 26.*



A STUDY ON IMPACT OF SOCIAL MEDIA MARKETING WITH SPECIAL REFERENCE TO FACEBOOK

Dr. S. Suguna

*Associate Professor, Department of Commerce with Professional Accounting,
Dr. N.G.P. Arts and Science College, Coimbatore*

J. Nithin Arun Raj

*171pa139, B.Com. (PA), Department of Commerce with Professional Accounting,
Dr.N.G.P Arts and Science College, Coimbatore*

ABSTRACT

Online media promoting has become the most impressive mode for organizations looking to reach out to their possibilities and clients. Given the wide reach of SMM, firms are progressively depending on it, In request to accomplish their advertising and marking goals .By supplanting the customary methods of promoting, online media has given new occasions to firms to lock in shoppers in social cooperation on the web. The goal of the current examination is to explore the capability of web-based media promoting as a successful showcasing apparatus that makes a difference them to influence impression of clients and eventually impact their buy choices. The study expects to feature the preferences that organizations gain by successful utilization of SMM.

INTRODUCTION

Social media are interactive Web 2.0 Internet-based applications. User-generated content, such as text posts or comments, digital photos or videos, and data generated through all online interactions, are the lifeblood of social media. Users create service-specific profiles for the website or app that are designed and maintained by the social media organization.

They introduce substantial and pervasive changes to communication between businesses, organizations, communities and individuals. Social media changes the way individuals and large organizations communicate. These changes are the focus of the emerging field of techno self-studies. In America, a survey reported that 84 percent of adolescents in America have a Facebook account. Over 60% of 13 to 17-year-olds have at least one profile on social media, with many spending more than two hours a day on social networking sites.

STATEMENT OF THE PROBLEM

Businesses are extensively making use of Social media in framing their marketing strategies. The main goal of this study has been to study the impact of social media and how it influences consumer's perception in turn to affect their buying behaviour. This study would be able to bring out whether advertising on social media does influence the consumer's buying behaviour so that companies can decide whether to continue with traditional marketing practices or whether to incorporate social media in their marketing strategies. Social networks refer to the connection, relationship and interactions that happen within the social media platforms.

Scope of study

The scope of this study is very wide because there are so many companies which are being involved in it now and will be involved in the future. This was citation briefing earlier, as the current companies that may be dealing with moving into social media are by far not the only ones that are



affected or will be affected in the future. Another reason that scope of the study is so broad is that it can be developed to include those that are not yet connecting to social media advertising but will be in the future.

Objective of study

- To analyse the socio demographic data with their personal factors.
- To study about the marketing strategies of social media marketing in current generation.
- To study and demonstrate the links between social media marketing efforts and their consequences.
- To study about the positive impact on the respondents of perception on online advertisements.
- To know about the acceptance of social media advertisement and marketing strategies among youths.

STATISTICAL TOOL USED

1. Simple Percentage Analysis
2. Rank Analysis
3. T- test Analysis

Limitation of study

- The sample units are confined to only Coimbatore city.
- The study is done without any mediating variable that can alter the relationship.
- Time of the study was limited only 6 months.
- The number of the respondents was limited to 120 only.

REVIEW OF LITERATURE

Bashar, Ahmad & Wasiq (2012)¹ has done an empirical research to understand the effectiveness of social media as a marketing tool and an effort has been made to analyse the extent social media helps consumers in buying decision making. Results of paper suggested that the medium is growing very fast and holds huge potential but is still in its nascent stage in India. Therefore, it is time for the companies to make effective strategies and execute them to win larger share of business through this revolutionary medium and become the innovative firm of coming future.

Yadav (2012)² has made an attempt to set up the significance of social networks as an advertising medium and evaluated the existing advertising methods that are in trend via certain case studies and concluded that social websites are not just a tool to interact with the different people but also medium to reach the prospective customers. **Akrimi and Khemakhem (2012)³** argued that social websites play a very important role to influence the buyers. Facebook has more than a billion users since its beginning in 2004. Social networks have strongly changed the spread of information by making it really easy to share (Akrimi and Khemakhem, 2012). As high-profile people are connected to Facebook, it is measured that if businesses are not available on Facebook, then it has no existence in the online world. Facebook has become an essential part to communicate strategies and facilitate marketing activities. It acts as an essential channel to position firms and its brands in the market (Khan & Khan, 2012).

DATA ANALYSIS AND INTERPRETATION

The data collected from the samples have systematically applied and presented in the tables under various headings in the following pages. They were also arranged in such a way that, a detailed analysis can be made so as to present suitable interpretation for the same. The data have been analyzed using the following statistical tools.

- Simple percentage analysis
- Rank analysis
- T- test Analysis

SIMPLE PERCENTAGE ANALYSIS

The percentage analysis is mainly employed to find the distribution of different categories of respondents. As the value are expressed in percentage it facilitates comparison and standardization. The analysis describes the classification of the respondents falling under each category.

**FORMULA
PERCENTAGE=**

$$\frac{\text{Number of respondents}}{\text{Total number of respondents}} * 100$$

TABLE NO: 1**Earning members in a family**

S. No.	Earning members in a family	No. of respondents	Percentage
1.	One member	39	30%
2.	2-4 members	43	33.07%
3.	5-7 members	38	29.23%
4.	Above 7 members	10	7.69%
	Total	200	100 %

*Source: Primary Data***Earning income in a family**

■ One member ■ 2-4 members
■ 5-7 members ■ Above 7 members

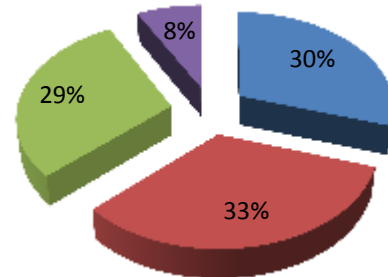
**INTERPRETATION**

The above table shows that 30 % of the respondents family has one earning member, 33.07 % of the respondents family has 2-4 earning members, 29.23% of the respondent family has 5-7 earning members and 7.69 % of the respondents family has above 7 members.

INFERENCE

It is inferred that majority (33.7 %) of the respondents family members has 2-4 earning members.



TABLE NO:2
Account type and Privacy

S.No	Account type and privacy	No. of respondents	Percentage
1.	Private/only friends	82	63.07%
2.	Public/everyone	48	36.93%
	Total	130	100 %

Source: Primary Data

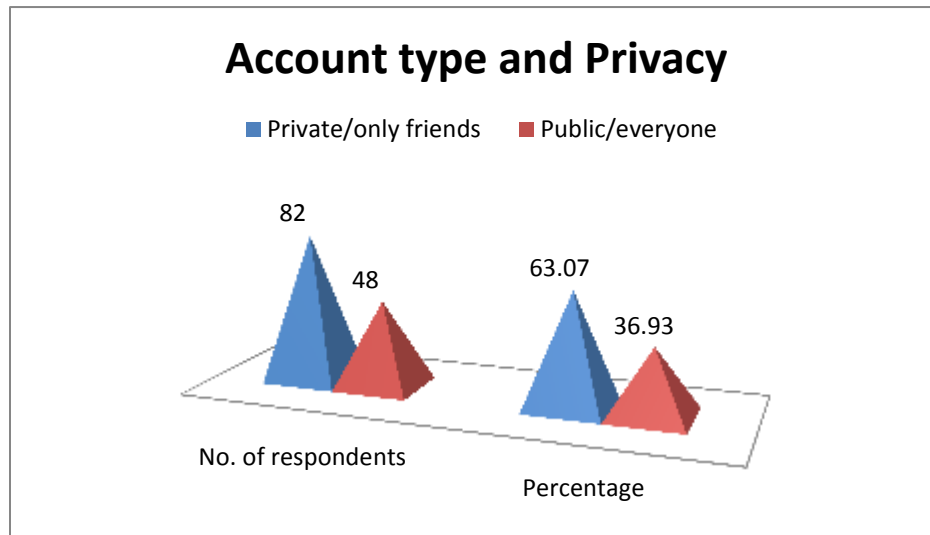

INTERPRETATION

The above table shows that 63.07 % of the respondents are having private/friends only account type and 36.93% of the respondents are having a public/everyone account type.

INFERENCE

It is inferred that most (63.07 %) of the respondents are having private/friends only account type.

RANK ANALYSIS

A Rank analysis is any of several statistics that measure an ordinal association. The relationship between ranking of different ordinal variables or different ranking of the same variable. Where a "ranking" is the assignment of the label "first", "second", "third", etc. to different observations of a particular variable. A rank analysis measures the degree of similarity between two rankings, and can be used to assess the significance of the relation between them.

**TABLE NO: 3**

S.NO.	FACTOR	1	2	3	4	5	TOTAL	RANK
1	High quality	8(5) 40	12(4) 60	18(3) 90	9(2) 45	17(1) 17	320	3
2	slogan	6(5) 30	12(4) 60	13(3) 65	24(2) 120	10(1) 10	325	2
3	Precise information	6(5) 30	16(4) 80	18(3) 90	13(2) 65	13(1) 13	335	1
4	Brand image	20(5) 100	12(4) 60	7(3) 35	9(2) 45	15(1) 15	240	5
5	High quality audio/video	27(5) 135	11(4) 55	7(3) 35	10(2) 50	8(1) 8	315	4

Source: primary data

INTERPRETATION

Among the various factors listed above the respondents have their own preferences towards different factors, which they feel as important. The respondents felt that precise information is the important facility, so this factor is most important thus it ranks number 1.

Apart from precise information the respondents prefer slogan factor is important thus it ranks number 2.

Nowadays peoples prefer high quality, thus it ranks number 3, apart from these the respondents also prefer high quality audio/ video and it ranks number 4. Apart from these the respondents prefer brand image and it ranks number 5.

INFERENCE

It is lucid that precise information was given the first rank; slogan factor were given the second rank and high quality having third rank, fourth rank was given to the high quality audio/video and finally, the fifth rank was given to brand image

FINDINGS, SUGGESTIONS AND CONCLUSION

FINDINGS

PERCENTAE ANALYSIS

- Majority (54%) of the respondent under the age – group of 19-25 years.
- Majority (57%) of the respondents are Female.
- Majority (76.15%) of the respondents are unmarried.
- Majority (52.30%) of the respondents income are Rs.2,50,001 – Rs.5,0,000.
- Majority (49.23%) of the respondents are graduate.

- Majority (60.76%) of the respondents are Students.
- Majority (42.30%) of the respondents are using social media for 1-3 years.
- Majority (60%) of the respondents are using social media for 1 hour – 2 hours in a day.
- Majority (69.23%) of the respondents are using other services provided in online by using social media account.
- Majority (91.53%) of the respondents are following other pages in social media.
- Majority (90%) of the respondents account type are private.
- Majority (50%) of the respondents are addicted to social media.
- Majority (55.38%) of the respondents are using social media to connect with people.
- Majority (93.07%) of the respondents see the advertisement in social media by mistake.
- Majority (95.38%) of the respondents exit when they watch videos after the advertisement.
- Majority (86.15%) of the respondents says that advertisement is not useful for them.
- Majority (70%) of the respondents says social media advertisements are sometimes eye catchy.
- Majority (93.84%) of the respondents are influenced by social media platform.
- Majority (63.84%) of the respondents are neutral to increase the brand awareness by ampute influencer.
- Majority (86.92%) of the respondents are satisfied by social media marketing.
- Majority (100%) of the respondents recommend social media to others.



SUGGESTIONS

- This study suggests that the social media influencer should concentrate under the age group of above 35 years.
- Most of the respondents are witnessing social media advertisement for the Brand Image.
- Most of the respondents says social media advertisements are sometimes eye catchy, if it were more attractive, they would use more promptly.
- Most of the respondents feels that they exit from videos as they mistakenly clicked on it, so videos should be informative.
- The social media should concentrate more in privacy factor concept. A non-aggressive in privacy factor lead to misruption in respondents view.

CONCLUSION

The study concludes that the users are preferring social media especially Whatsapp and Instagram. From the survey younger generation and middle age are more interested in social media, the buying behavior is governed predominantly by the need of power and respect for the iconic brand and users are mostly employed females, 19-25 years of age, including some students. Most of the customers are attracted to the new release of updations, users are addicted to the social media platforms. Most of them prefer to use social media to connect with people. Most of the users recommend social media marketing to others.

REFERENCE

1. *Bashar, A., Ahmad, I., & Wasiq, M. (2012). Effectiveness Of Social Media As A Marketing Tool: An Empirical Study, International Journal Of Marketing, Financial Services & Management Research, 1(11), 88-99.*
2. ¹ *Yadav, N. (2012). Social Networking Sites-A New Vechicle for Advertising. MIMT Journal of IT & Management Research , 2 (1), 38-48.*
3. ¹ *Akrimi, Y., & Khemakhem, R. (2012). What Drive Consumers to Spread the Word in Social Media? Journal of Marketing Research & Case Studies, 2012, 1-14. <http://dx.doi.org/10.5171/2012.969979>*



FATS - FATS IN FOOD PRODUCTS AND THEIR PROPERTIES

Sulaymonova Gulchexra Xakimovna

Bukhara Engineering - Technology Institute, Ph.D. in Technical Sciences

Ashurova Muxabbat Zoirovna

Bukhara Engineering - Technology Institute, Candidate of Technical Sciences, Docent

Ganieva Nasiba Xikmatovna

Bukhara State University, Teacher

Naubeev Temirbek Xasetullaevich

Karakalpak State University, Docent

ANNOTATION

The article focuses on food production technologies. The industry mainly uses the method of neutralizing free fatty acids with alkali. Alkaline cleaning is common. Thus, a fat-insoluble salt of fatty acids - soap is formed. Its aqueous solution separates from the oil due to its high density. The separated soap mass is called soap stock. The production technology of Soapstock is also reflected.

KEYWORDS: *Phospholipids, pigments (carotene, xanthophyll, gossypol, chlorophyll, hydration, alkaline cleaning, bleaching, deodorization).*

Annotatsiya

Maqolada asosan oziq-ovqat mahsulotlarining ishlab chiqarish texnologiyalar haqida fikr yuritiladi. Sanoatda asosan erkin yog' kislotalarini ishqor bilan neytrallash usuli ishlatiladi. Ishqorli rafinatsiya keng tarkalgandir. Bu usulda yog' kislotalarini yog'da erimaydigan tuzi ya'ni sovun hosil bo'ladi. Uning suvli eritmasi katta zichlik hisobiga yog'dan cho'kmaga tushib ajraladi. Ajralgan sovunli massa soapstock deyiladi. Soapstockning ishlab chiqarish texnologiyalari ham o'z aksini topgan.

Kalit so'zlar: Fosfolipidlar, pigmentlar (karotin, ksantofill, gossipol, xlorfill, gidratatsiya, ishqoriy rafinatsiya, oqlash, dezodoratsiya).

INTRODUCTION

On January 16, 2018, President of the Republic of Uzbekistan Shavkat Mirziyoyev signed a decree "On measures to further ensure food security of the country."

Further ensuring food security of the country, filling the market with quality, safe and affordable food products, strengthening the purchasing power of the population, liberalization of foreign economic activity and the development of a healthy competitive environment, as well as



eliminating existing systemic problems in this area Individual customs, tax and other benefits, as well as other preferences provided to certain business entities for the import of food products into the Republic of Uzbekistan from February 1, 2018 have been abolished.

It is also necessary to take comprehensive measures to find and attract food carriers for 2018, to create equal conditions for them to enter the market, to conclude contracts, to assist in the transportation and storage of imported products, as well as quality, affordable population. other measures will be developed to fully meet the demand for food products.

Saturation of the market with quality, safe and cheap food products, development of the agrarian complex, introduction of effective mechanisms of social and public-private partnership, timely elimination of threats to the stability of the food market, import of food products The draft law "On Food Security", which defines measures for favorable customs and tariff regulation, has been developed and submitted to the Cabinet of Ministers for a number of tasks [1]. There will be a number of changes in the educational process to ensure the implementation of the above law.

In the age of globalization, in the context of rapid development of science, technology and engineering, the following requirements are set for the education system:

- i. development of skills of individual and independent work, as well as creative work with scientific and technical information;
- ii. development of original and non-standard thinking and business skills;
- iii. individualization of education due to the fact that students have different learning abilities;
- iv. the mobility of knowledge, the formation of critical thinking, creativity and dexterity at work, the ability to adapt to changing production conditions.

Of course, it is safe to say that the quality of food professionals is the basis for tomorrow's development. This is due to the role of human resources in the primary processing of all domestic goods produced in our country and their quality delivery to the people.

In this regard, the import of a number of innovative technologies in the field of food.

PROCESSING OF VEGETABLE OILS

Industrially produced vegetable oils contain a mixture of triglycerides and fatty substances. Fatty substances accumulate in the adipose tissue of the plant and the fat is separated and they are called accompanying substances. These substances, even in small amounts in fats and oils, have a significant effect on its properties. These include phosphorus-

containing substances (phospholipids), pigments (carotene, xanthophyll, gossypol, chlorophyll), waxes (waxy substances), tocopherols and fat-soluble vitamins, sterols (steroids), free fatty acids, flavors and other odoriferous organic substances, sulfolipids, glycolipids, glycoproteins, phosphoprotein compounds. While some of the accompanying substances spoil the color, smell and taste of the oil, adversely affecting its nutritional and commodity quality, some complicate further processing. Refining is the process of removing fats from their constituents.

Refining is a complex complex of various physical and chemical processes, the application of which allows to separate the accompanying substances from the oil. The nature of these processes is determined by the nature of the oil and the intended use of the refined oil.

In the oil industry, oil refining processes are carried out in the following sequence: hydration - alkaline refining - bleaching - deodorization.

The refining method should be chosen in such a way that the triglyceride content of the oil remains unchanged, the maximum amount of valuable by-products (phosphatides) is removed from the oil and the complete elimination of toxins is ensured.

There are several requirements for refined oils, depending on their purpose. Fats used in food must be refined in a complete cycle: the separation of phosphatides and waxy substances, the loss of free fatty acids, pigments. Oils used for technical purposes are refined in a short cycle. For example, hydrogenated oil is not deodorized.

It is impossible to get rid of all the accompanying substances in one way. Therefore, in practice, several methods are used that combine into one technological scheme.

Hydration of oils. Hydration is performed to isolate phosphatides. The amount of phosphatides depends on the type of oil and the method of obtaining it. For example, forpress soybean oil is 1.0-1.5%, extraction soybean oil is 1.5-3.0%; 0.3-0.7% in forpress sunflower oil, 0.9-1.2% in extraction oil; The phosphatide molecule has a diffuse character: the hydrophobic part is a fatty acid radical; hydrophilic part - the active group (ether, nitrogenous base, hydroxyl, etc.) Although the amount of phosphatides in oils is low and non-toxic, it has a significant impact on the quality of the oil due to its activity. During storage, it forms a precipitate and crushes the oil. They stabilize the emulsion and as a result the phases are difficult to separate, during bleaching phosphatides are adsorbed on the sorbent surface, which increases its consumption.

During hydrogenation, phosphatides reduce catalyst activity. This suggests the need to separate phosphatides from unrefined fats. The basis of the

hydration process is that the phosphatides interact with water, coagulate, and precipitate.

PHOSPHATIDES ARE USED IN CONFECTIONERY

The amount of hydrating water depends on the amount of phosphatide, its composition, structure, and it varies from 0.5% to 6%. Lack of water leads to incomplete hydrotastia, while excess water forms an emulsion.

During hydration, the number of fatty acids decreases by 0.4-0.5 mg KOH (due to the separation of acid phosphatides), along with phosphatides, proteins and mucous substances are released.

After the hydration process, 0.1-0.2% phosphatides remain in the oil. To remove unhydrated phosphatides, the hydrated oil is treated

with concentrated phosphoric acid. Hydration method: In various schemes, a reactor-turbolizer is used to mix water and oil, and separators or plate precipitators are used to phase the oil-phosphatide emulsions.

Hydration technology consists of the following operations

- i. mixing of oil with hydrating agent;
- ii. an oil-water mixture to form the coagulation process of phosphatides
- iii. search;
- iv. separation of oil and phosphatide emulsion phases;
- v. oil drying;
- vi. drying of phosphatide emulsion and obtaining phosphatide concentrate.

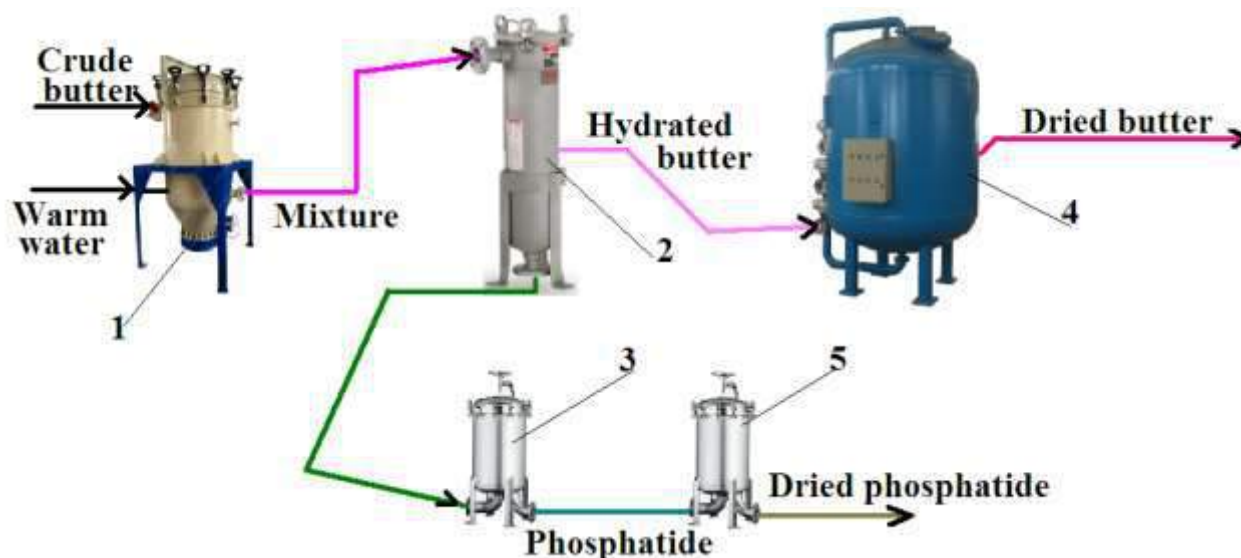

Figure-1: Schematic diagram of the hydration process.

Alkaline refining of oils. Vegetable oils contain a certain amount of free fatty acids, which depends on the quality of the oil. The presence of free fatty acids worsens the quality of fat and reduces its nutritional value. The acid content of the fat used in food should not exceed 0.2-0.3 mg of KOH.

The industry mainly uses the method of neutralization of free fatty acids with alkali. Alkaline refining is common. In this way, a fat-insoluble salt of fatty acids, soap, is formed. Its aqueous solution separates from the oil due to its high density. The separated soapy mass is called soapstock. Due to its high adsorption properties, soap separates the following compounds from oil: phosphatides, proteins, mucous substances, dyes, and due to this, the refined oil is partially bleached. Partial bleaching

of the oil is also due to the reaction of the alkali with some coloring satellites (gossypol).

Therefore, an excess of alkali is obtained. Excess alkali depends on the nature and quality of the refined oil. Excess alkali is 5-50% for light oils and 200-300% for dark and difficult to refine oils. The concentration of alkali is from 10 to 300 g / l, depending on the type and quality of the oil. Water is added to the concentrated alkaline solution to prepare a working solution of the desired concentration. Thus, soapstock, which is a waste of the refining process, contains: soap, neutral oil, impurities, a certain amount of alkali, water, additives. Because soapstock contains fatty substances, it is used as a raw material in the production of fatty acids.

The course of the refining process and the structure of the soapstock structure depend on the



temperature, alkali solution, concentration and process conditions of the oil. The temperature of the process depends on the concentration of the alkali solution. The higher the alkali concentration, the lower the process temperature. Typically the temperature is between 20-25°C (for cottonseed oil) and 80-85°C (for sunflower oil).

The technological method of oil refining is selected mainly depending on the color of the oil. Dark colored (cotton, linseed) crude oils are mainly refined periodically, while light colored (soybean, sunflower) crude oils are refined continuously. The periodic refining is carried out in neutralizers with a volume of 5, 10 and 20 t. Refining is carried out as follows:

The crude oil and alkali solution are mixed (1) and the temperature in the neutralizer is raised (60-65°C) until soapstock particles are formed and then cooled (2). The refined oil was drawn through a hinged tube into a washing and drying vacuum apparatus (3). After the soapstock is separated, 0.05-

0.3% of soap remains in the oil, which spoils the taste of the oil, oxidizes it and reduces the activity of the catalyst during hydrogenation.

The oil is washed off to remove any remaining soap. Soap content should not exceed 0.05%. Drying is carried out at a temperature of 90-95°C and vacuum (residual pressure 20-40mm.sm.us.). Washed and dried oil is a ready-made refined oil. Soapstock is downloaded to a special bank.

The disadvantage of the periodic method is the long soaping time, the high amount of neutral oil in the soapstock, and the long soaping process of the neutral oil. Soapstock fat content is 30-50%.

In the continuous refining method, neutralization is carried out in mixers, and phase separation is carried out in separators. There are continuous production lines A1-JRN (capacity 80-120 t / h), Alfa-Laval (capacity 80-180 t / h), Westfal (capacity 300 t / h).

Refined oil must have the following characteristics:

Table-1

Color, in red unit.	7	10
Acid number, mg KOH	0.2	0.3
Moisture and volatile substances, %	0.1	0.2
Flash temperature, °C	232	232

Whitening oils. Of the satellite substances, carotenoids are resistant to alkali, so they do not decompose in alkaline refining. At high concentrations of alkaline solution, carotenoids are sorbed into the soapstock during neutralization and the oil is partially bleached. Carotenoids are actively sorbed on the surface of a solid sorbent.

Unlike carotenoids, chlorophylls react with alkali to form a compound. However, in alkaline refining, it does not completely separate.

Sunflower oil contains carotenoids and chlorophylls, while cottonseed oil also contains gossypol. Adsorption purification method - bleaching is used to remove oil dyes.

Good adsorption depends on the nature and structure of the adsorbed substances.

For example, non-polar (poorly polar) compounds are well sorbed in non-polar adsorbents (in coal) and polarized compounds are well sorbed in polar sorbents.

The nature and structure of all dyes in oils and fats are different. But they each have their own polarity. Therefore, polar adsorbents with selectivity and activity in adsorption refining of oils: natural bentonite soils are obtained from aluminosilicates. More active, with an oil content of 75%, soil-ascanite

is used. Adsorbents must be highly adsorbent, dispersed, have a low oil capacity and do not chemically react with oil, and must be oil-free.

The efficiency of the bleaching process is determined by the color of the bleached oil, the amount of sorbent used, the rate of loss and waste, and the amount of bleached oil released.

When activated soil is used during the bleaching process, some isomerization and some glycerides are formed. This leads to a decrease in the quality and shelf life of refined oils and fats. Whitening time is 20-30 minutes.

Prolonged retention of the oil with the adsorbent leads to its oxidation and the oil tastes dirty. It is therefore necessary to minimize the amount of activated soil used for bleaching and the time of soil contact with the oil.

Hydrated, neutralized, washed and dried oils are recommended for bleaching, and the process is carried out under vacuum to reduce oxidation during bleaching.

In recent years, the world has installed hermetic filters for mechanical sedimentation of various designs, and continuous bleaching methods have been introduced. The justification process for all methods is based on the following principle:

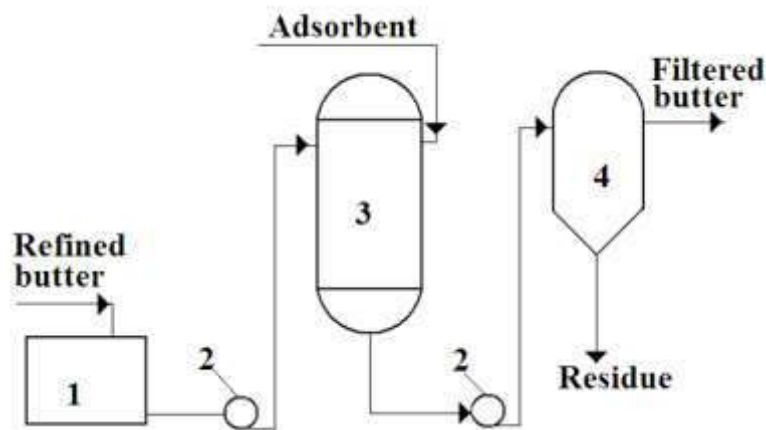

Figure-2. Preparation of oil suspension of adsorbent.

2. deaeration, the process of whitening; The bleaching process is carried out for 20-30 minutes at a temperature of 75-80°C and a residual pressure of 4 kPa (around 40 mm Hg).

3. Separation of the adsorbent using a filter. The pressure in the filtration should be 2.5-3 atmospheres and the temperature should not exceed 85-90°C.

Deodorizing oils. The final stage of the refining process is deodorization (deodorization), the purpose of which is to eliminate the unpleasant taste and odor in the oil. This taste and smell are created by a mixture of complex substances in the oil. These substances include low molecular weight fatty acids (caprine, caprylic), aliphatic hydrocarbons, natural essential oils, aldehydes, ketones, oxy acids. Other toxic organic compounds are also lost during deodorization. The essence of the deodorization process is the evaporation of aromatic substances in the liquid layer.

The effectiveness of deodorization depends on the composition of the aromatic substances, their volatility and the process temperature. As the temperature rises, the volatility of aromatic substances increases. However, too high a temperature can lead to the polymerization and oxidation of oils. When the temperature exceeds 250°C, the oils decompose thermally. Therefore, in order to reduce the temperature when driving aromatic substances, the deodorization process is carried out under the influence of sharp steam under vacuum.

The quality of edible oils also depends on the completeness and completeness of the deodorization process. Therefore, deodorization is one of the main processes in oil refining.

In addition to the general requirements for obtaining high quality deodorized oil, the following requirements must be observed:

- i. The oil should not be kept at high temperature for as long as possible during deodorization.
- ii. Deodorization of oils must be carried out before deodorization.
- iii. 3. Avoid contact with moist air during deodorization and cooling of oils need to save.
- iv.
- v. If the equipment is stopped after deodorization, it should be degreased and all parts should be washed and cleaned.

Various deodorants are used to deodorize oils:

Periodic (intermittent) deodorizers, Continuous deodorizers (De-Smet, Pinch-Bamag, Ole). The temperature during the periodic deodorization process is 170-210°C, and during the continuous process it is up to 230°C. The residual pressure in the apparatus is 5 mm. equal to a column of mercury. Multi-stage steam projectors (steam pumps) are used to create the vacuum.

Oils and greases should be thoroughly refined before deodorization.

Deodorating oils and greases should be free of soap and bleach residues. If the deodorizing oil contains soap or bleach residue, it is sent for re-filtration.

To maintain the quality of the deodorized oil, 0.6 l of citric acid solution (20%) is added to 1 ton of oil during deodorization.

The steam supplied for deodorization must be free of salt, oxygen and other gases, and the steam must be dry and neutral.

The description of the principle scheme of periodic deodorization is as follows:

The refined oil is vacuumed from the tank into the deodorizer and the deodorizer is half-filled with oil. The oil is heated to a temperature of 100 °C and the deodorizer is supplied with open steam from



the bottom barboter. When the temperature reaches 180°C, the amount of steam increases. The vacuum in the deodorizer is created by a block of steam injectors. The residual pressure in the apparatus is 5mm. sim. should not exceed the column. The vapor-air mixture coming out of the deodorizer is sucked into the vacuum system through the drip trap and trapped in the dropper trap.

The deodorization temperature is around 180 °C for coconut oil and 210-230 °C for salomas and other vegetable oils.

Deodorization time is about 1.5-3 hours. The deodorized oil is cooled and delivered to the packaging department.

CONCLUSION

Based on the above technologies, we can conclude that the raw materials and materials of the food industry are heterogeneous systems, which are solids and carbonated liquids with different structures. The thermophysical properties of such materials depend primarily on their chemical composition and humidity, which can change significantly during processing. It should be noted that the method and speed of heating or cooling may change the structure and properties of the product. By studying the thermophysical quantities of materials, evaluating the thermophysical properties of food products and correctly linking them to the technological processes of processing, ensures product quality. Therefore, the principle of operation of the hydration process is shown in the first picture above, which highlights the positive effects of improving the amount of COPs in food on human health. In our article, we can not say that all the oils produced today are good, and in this regard, the analysis of the performance of innovative technologies in the field is made.

LIST OF USED LITERATURE

1. *O'zbekiston Respublikasi Prezidenti Shavkat Mirziyoyev 2018-yil 16-yanvar kuni «Mamlakatning oziq-ovqat xavfsizligini yanada ta'minlash chora-tadbirlari to'g'risida»gi farmoni.* <https://www.xabar.uz/uz/jamiyat/oziq-ovqat-boyicha-vangi-qonun-loyihasi-ishlab>
2. P. J. Fellows, *Food Processing Technology: Principles and Practice 3rd Edition*: Woodhead Publishing, USA, 2009
3. Y.Qodirov, D. Ravshanov, A. Ruziboev "O'simlik moylari ishlab chiqarish texnologiyasi". Darslik. "Cho'lpon", Toshkent, 2014, - 320 b.
4. Vasiev M, Dodaev Q, Isabaev I, Sapaeva Z, Gulyamova Z "Oziq-ovqat texnologiyasi asoslari". Darslik. Voris nashriyoti. Toshkent – 2012 y - 400 b
5. Adizov R.T. "Don va don mahsulotlarini saqlash texnologiyasi". Darslik. "Fan". Toshkent – 2012 y. 432 b.
6. Yusupbekov N.R., Nurmuhamedov X.S., Ismatullaev P.R., Zokirov S.G., Mannonov U.V. *Kimyo va oziq-ovqat sanoatlarining asosiy jarayon va qurilmalarini hisoblash va loyihalash. - Uslubiy qo'llanma. T.: Jaxon, 2000. -231 b.*
7. Abidov B. *Neft-gaz sintezi asoslari: o'quv qo'llanma/ B. Abidov, O.G'. Azimov, U.A. Ziyamuhamedova; O'zbekiston Respublikasi Oliy va o'rta maxsus ta'lim vazirligi: O'rta maxsus kasb-hunar ta'limi markazi. – Toshkent: «Faylasuflar» nashriyoti, 2013. – 176 b.*
8. Мирзаев, С. С., Кодирова, Н. Д., Нуруллаев, М. М., & Хужжиев, М. Я. (2013). Изучение энергозатрат при плазмохимической диссоциации сероводорода. Молодой ученый, (2), 49-52.
9. Давронов, Ф. Ф. У., & Хужжиев, М. Я. (2018). Изучение процесса очистки газов физической абсорбцией. Вопросы науки и образования, (3 (15)).
10. Хужжиев, М. Я. (2018). Изучение методов конверсии метана в синтез-газ. Научный аспект, 7(4), 852-854.
11. Усанбоев, Ш. Х. У., & Хужжиев, М. Я. (2017). Основные свойства катализаторов гидроочистки. Вопросы науки и образования, (5 (6)).
12. Кобилов, А. Б. У., & Хужжиев, М. Я. (2017). Механизм поглощения H₂S, CO₂ и других сернистых компонентов водными растворами аминов. Вопросы науки и образования, (11 (12)).
13. Бурхонов, И. У., & Хужжиев, М. Я. (2017). Сравнительный анализ эффективности работы аппаратов воздушного и водяного охлаждения нефтеперерабатывающих заводов. Вопросы науки и образования, (2 (3)).
14. Ризаев, Д. Б., & Хужжиев, М. Я. (2017). Очистка газовых выбросов. Вопросы науки и образования, (5 (6)).
15. Хужжиев, М. Я. (2016). Очистка и осушка газов растворами гликолей. Наука и образование сегодня, (3), 33-34.
16. Хужжиев, М. Я. (2016). Изучение процесса риформинга и подготовки нефтепродукта. Наука и образование сегодня, (3 (4)).
17. Хужжиев, М. Я., & Хайдаров, Г. А. У. (2016). Изучение характеристики физических поглотителей для очистки газов. Наука и образование сегодня, (3 (4)).
18. Хужжиев, М. Я., & Нуралиев, С. С. У. (2016). Очистка газов водными растворами метилдиэтанолamina. Наука и образование сегодня, (3 (4)).
19. Хужжиев, М. Я. (2016). Материалы и реагенты для приготовления промывочных растворов в нефтехимической отрасли. Наука и образование сегодня, (3 (4)).
20. Сафаров, Б. Ж., Хожиев, А. Х., Хужжиев, М. Я., Таипулатов, С. К., & Равшанов, М. М. (2016). Выбор режима разделения газожидкостных систем. Наука и образование сегодня, (3 (4)).



21. Хужжиев, М. Я., & Нуруллаева, З. В. (2015). *Полимеризация газообразных углеводородов в жидкое топливо. Молодой ученый, (8), 332-334.*
22. Nikolayevich, Tsukanov Maksim, and Khodzhiev Mamurzhon Yangiboevich. "ANALYSIS OF DEVELOPMENT OF TECHNOLOGY OF PRODUCTION OF SECONDARY PRODUCTS FROM PYROLYSIS DISTILLATE." *EPRA International Journal of Multidisciplinary Research (IJMR)*: 246.



LOAN VOCABULARY OF THE TAJIK LANGUAGE IN SAMARKAND DIALECT

Abduvakhob Vakhidov

Samarkand State University, Uzbekistan

ABSTRACT

The article is devoted to the study of loan vocabulary of the Tajik language in Samarkand dialect. The analysis showed that the largest number of loans was made from Arabic, Uzbek and Russian-European languages, and most of them are associated with socio-political and cultural transformations of society.

KEY WORDS: *loan, vocabulary, Arabic, Uzbek, Russian-European, Samarkand dialect, literary language, Tajik language.*

1. INTRODUCTION

The local dialects are considered an integral part of the history and culture of any people and nation. The Tajik dialects, is one of the main sources of development and improvement of the lexical composition of the Tajik normative language, which reflect the socio-political and cultural transformations of modern society. The dialects of the Tajik language have not yet been examined from the standpoint of the requirements of modern linguistics, despite the ample opportunities available and the corresponding scientific potential. The researchers, mainly addressing the phonetic and morphological issues of dialects, provided general information about their vocabulary and syntax. There are few works that are directly devoted to the vocabulary of Tajik dialects. At the same time, it is quite problematic to carry out their comparative, contrastive and generalizing analysis, which is required by the current state of development of the Tajik language, without a comprehensive study of the vocabulary of all the Tajik speech and dialects. The Tajik language has a fairly rich material of the vocabulary of dialects. The literary language, at any time can strengthen its lexical resources at the expense of commonly used dialectological elements, if necessary. The Tajik language received the status of the state language, at the same time literary style needs to diversify its own lexical corpus, when especially at this stage of development. The solution to this problem implies that the vocabulary of each dialect of the Tajik language separately should be subject to comprehensive analysis. It has created favorable conditions for the development of all branches of

science in the period of independence of the Republic of Uzbekistan. Now, there are some important tasks for linguists: a) the study of the vocabulary of each dialect, b) comparison with other dialects of the vocabulary, c) the literary language and, thus, the formation and selection of the necessary units of speech due to their common elements. This approach is due to the fact that the improvement of the lexical and terminological system of the Tajik language, the compilation of bilingual, explanatory, industry and other dictionaries without a comprehensive study of local dialects cannot give positive results.

2. THEORETICAL BACKGROUNDS

There is a fact that study of Tajik dialects began at the beginning of the XX century (see: 50; 219; 106). However, these linguistics works were short and descriptive character do not reflect all the features of Tajik dialects. The study of dialects of the Tajik language essentially began later. Especially a lot of research literature and scientific articles were published in 50s of the XX century. The comparative and generalizing works of a number of researchers of Tajik dialectology appeared in this area in 60-80s (second half) of the XX century. As is known, the study of dialects of the Tajik language, starting with the collection of materials from individual dialects, has reached the level of comparative study and scientific generalization of dialects. But the consideration of individual sections of the dialectal system of speech in Tajik dialectology developed unevenly. Separate works and articles have been published on dialect vocabulary since 60s of the XX century. Most of the collection "The issues of the



Tajik dialectology (1970)" is devoted to the study of the vocabulary of individual dialects. The publication of the bilingual Tajik-Russian dictionary by V.S.Rastorgueva in 1963, compiled on the basis of materials from the northern dialects, was a great achievement in Tajik dialectology. This work actually served as the beginning in the compilation of dialect dictionaries and a large-scale study of dialects of the Tajik language. In 1971s the dictionary by G. Dzhuraev and M. Makhmudov was published in fragments. The great samples were included of almost all dialects of the Tajik language and were published the dissertation on the topic of the vocabulary and phraseology of dialects of Isfara and the second volume of M. Eshniyozov's textbook "Tajik dialectology". In the same period were published four articles by G. Dzhuraev and A. Z. Rosenfeld on individual dialects, a number of articles by Sh. Ismoilov on the vocabulary of the dialects of the Rasht valley, an article by B. Berdiev related to the vocabulary of the Romit dialect. In 1980, the was published the first volume of the multivolume work "The southern dialects of the Tajik language", which the second section is devoted to the study of the vocabulary of the southern dialects. From the beginning of 80s of the XX century (to the present day), quite a lot of research has been carried out in the field of vocabulary of dialects of the Tajik language e.g. PhD and doctoral dissertations have been defended. It has been published the bilingual dialect dictionary and the dialect explanatory dictionaries. The Tajik scientific community received a guide on collecting a dictionary of dialects of the Tajik language, a methodological manual on teaching the norms of the Tajik literary language in a dialect fields. It becomes clear that most of the structure of scientific works devoted to these issues, concern the study of the phonetic and grammatical structure of dialects. The study of dialectal vocabulary in Tajik linguistics was not carried out in a concrete way until the second half of 70s of the XX century. The first examples in which the lexical features of one or several identical groups of dialects are directly examined by dissertations of T. Maksudov, R.L. Nemenova, G. Dzhuraev, Sh. Ismoilov, and by scientists M. Kabirov, M. Kakhkhorov, B Osimova, M. Khalimova, A. Kasanov, S. Uzbekov, N. Gadoev, Z. Zamonova, R. Sanginova, G. Abdulloeva research confirm the active dynamism of the development of this direction of Tajik linguistics.

3. THE FORMATION OF SAMARKAND DIALECT

It becomes clear from a brief analysis of the literature that in the field of studying the peculiarities of the vocabulary of dialects there are still many unexplored materials in Tajik dialectology. Today,

the vocabulary of the group of dialects of northern dialects, central and southeastern dialects, and also transitional ones has not been sufficiently studied. This situation makes it possible to study the vocabulary of dialects of the Tajik language outside of Tajikistan, in particular Uzbekistan as a whole system. In this direction, a comprehensive study of the vocabulary of Samarkand dialect of the Tajik language deserves special attention. This aspect lack of study that led to the study of the vocabulary of the current dialect. The vocabulary of Samarkand dialect of the Tajik language covers a large amount of materials and needs a separate research and study.

Therefore, the study of the vocabulary of this dialect is important because:

- The vocabulary of this dialect with all its specifics has not yet been studied;
- Thematic and semantic features of the lexical elements of this dialect have not yet been analyzed;
- The linguistic affiliation of dialectisms, the types and boundaries of their distribution have not been determined;
- The dialect has peculiar models of word formation, which have not yet been considered;
- This dialect has retained the originality of its vocabulary;
- Samarkand was the center of culture and civilization of the East in the past.

In the way of studying and researching the vocabulary of this dialect can help determine the development of the Tajik language in a particular historical area which the lexis also has stylistic features, the study of which is a requirement of the time of current dialect. DSn, Professor R. Gafforov emphasizing the need to collect and study the vocabulary of dialects, and notes that "part of the dialect vocabulary associated with objects and old terminology, depending on the extinction of traditions and customs, lifestyle and past life thinking, disappears. Therefore, it is necessary quickly and efficiently collect them, before disappearance" (7). Loan vocabulary is more independent in the use of borrowed vocabulary in relation to other dialects. of Samarkand dialect of the Tajik language. The influence of foreign languages is still felt in the speech of the speakers of this dialect. The appearance leaves mark on the language of any phenomenon which associated with political, economic, social and cultural events. This process takes place gradually i.e. the first, loan vocabulary appears in the dialect, then slowly acquires a common feature and finally it becomes necessary to use them in the literary language. The process of entering Arabic, Uzbek and Russian-European vocabulary depends precisely on some external and internal factors in the development and transformation of dialectal speech. For example, the



process of load Arabic vocabulary into the Tajik language gains wide scope mainly in political, economic, scientific and cultural centers with the establishment of the Islamic religion and the proclamation of the Arabic language as the official language in the VII-IX centuries in Central Asia. Later, this phenomenon affected the speech of the population of Samarkand. Words, religious semantics were loaned into Samarkand dialect of the Tajik language such as: *namoz*, (*namaz*), *shahodat* (*death*), *qiroat* (*reading*), *id* (*holiday*), *iftor* (*iftar meal*), *halol* (*permitted*), *harom* (*unlawful*), *taloq* (*divorce*) etc.

The number were increased gradually due to Arabism denoting administrative, philosophical, socio-cultural concepts. Arabic words in the speech of the local population were learned in the way of their pronunciation occurred according to the pronunciation norms of the Tajik language. This group includes lexemes such as: *mullo* (*mulla*), *rais* (*chairman*), *ḡayot* (*life*), *insof* (*justice, conscience*) etc. After the Arabic loan, Uzbek lexical units were and still use in terms of position and degree of in the Tajik language. The researchers are of the opinion that the process of incorporation of elements of Uzbek lexical loan began as early as the XI century and continued in the XVI-XVIII centuries in process of the influence of the Uzbek language to the Tajik language. However, during this long historical period, the transfer of Uzbek loan words to the Tajik literary language was not one of the notable phenomena. It must be admitted: "The widespread use of Uzbek vocabulary begins with Ahmad Donish and Savdo, and S. Aini completes the aspirations of these enlighteners with his original style" (29). The Uzbek lexical elements are primarily used to faithfully depict historical, political and social events in the language of fiction. In this sense it would have turned out to be unofficial, less influential, fake and artificial without literary figures. The inhabitants of Samarkand were more free in the use of Uzbek words. They do not use all loan vocabulary that is used in literary speech, but mainly those words that do not have synonyms in the Tajik language, e.g. *qoshuq* (*spoon*), *qaburg'a* (*rib*), *qavoq* (*eyelid*). Also the Uzbek vocabulary is used mainly to express related concepts, names of geographical areas, body parts, the names of some animals, birds, food, plants, etc. It can be noted that it in northern dialects began with the capture of Central Asia by Russia (late XIX century) if pay attention to the process of the entry of Russian-European loan words into the vocabulary of Tajik dialects. R.L. Nemenova and G. Dzhuraev point out two ways of loaning Russian words as:

- i) Official;
- ii) Unofficial.

They believe that the use of Russian and Russian-European words became inevitable i.e. such lexical units entered and/or loaned the official way,

the use of which was prompted by the political system, and gradually acquire a dialectal essence, by satisfying the needs of individuals, such lexical units are unofficially included in the vocabulary of dialects. As a result, one Russian-European word has the following forms: *nalo'k* (*tax*), *noni bo'lka* (*bread*) etc. The Russian-European words were considered appropriate by native speakers of the dialect use in the following cases:

1) The absence of their synonyms in the Tajik language: *traktir* (*tractor*), *kambine* (*combine*), *boshpurt* (*passport*) *radiyo* (*radio*);

2) Part of the Russian is active to consider a product of the dialect vocabulary in the Tajik language: *katishka* (*potato*), *pamidor* (*tomato*), *agarot* (*garden*);

3) Russian-European vocabulary is used to demonstrate "their advantage and cultural level: *istarchy* (*senior*), *mihainik* (*mechanic*), *vihadnoy* (*weekend*), *pirkaz* (*order*);

4) Also used to express metaphorical concepts of the Russian-European vocabulary in the Tajik dialects: *krisha* (*roof, patron*), *pulimiyot* (*machine gun*);

5) Russian-European vocabulary can be used in the form and composition of phrases, as well as participate in the formation of phraseological units: *kraska kardan* (*to paint*).

It should be mentioned again that acquires various phonetic, grammatical and lexical features loan vocabulary, depending on the assimilation in the dialects of the Tajik language. In view of this, we will consider them separately.

3.1. THE ARABIC LOAN

The researchers, considering the Arabic vocabulary among the most ancient loaned elements of the Tajik language, with the invasion of Arab tribes into Central Asia, the establishment of the Islamic religion, the adoption of the Arabic language in the region for two hundred years as the language of science and culture as the main factors of their entry into the vocabulary of our language. It was mainly involved in the study of Arabic loan in the Tajik language considering borrowings of this type in Tajik dialectology, notes that "The study of loaning of the Arabic language on the basis of dialects of the Tajik language is of the greatest importance, since in this matter dialects differ in comparison with the literary language" (20) by T. Berdieva, G. Dzhuraev. The assimilation of general Tajik properties and the acquisition of certain phonetic, derivational and semantic features of Arabic words in Tajik dialects were studied in the works of scientists T. Maksudov, Sh. Ismoilov, N. Gadoev, G. Abdulloeva, etc. The process of penetration of Arabic vocabulary into Samarkand dialect of the Tajik language took place along with their entry into the vocabulary of the



literary language. The use of loan Arabic words for a long time in this dialect turned them into an active lexical and grammatical element of the dialect. Such elements of speech in the lexical composition of this dialect are found in the following forms: a) the words that have been preserved without changing their form and meaning; b) the words that have undergone phonetic change, but have retained their basic meaning; c) the words that have lost partially or completely their previous meaning are used to express other concepts; d) the words that were desemantized in the dialect based on metaphor; e) the words that serve as word-formation bases for the formation of new lexemes. The first group includes the following words such as: *varam* (tumour), *dallol* (mediator), *ziq* (sad), *zot* (breed), *ibo* (shyness), *imo* (gesture), *isrof* (waste), *ishtiya* (appetite), *mazor* (cemetery), *mashq* (exercise), *maqul* (expedient), *mojaro* (scandal), *mumsik* (greedy), *mo'khlat* (term/period), *mo'htoq* (needy), *nikoh* (marriage), *niyat* (intention), *raʁm* (pity), *sadaqa* (alms), *sair* (walk), *sala* (turban), *ojiz* (powerless), *tamiz* (neat), *halos* (deliverance), *hotir* (memory), *shal* (paralysis), *for* (cave), *qadam* (step), *qadim* (ancient), *qaror* (decision), *qasam* (oath), *qasd* (intention/purpose), *qassob* (butcher) etc. The most of these words in the literary language and Tajik dialects are learned to such an extent that it is difficult to distinguish them from Tajik elements. They are also considered an active element during word formation. Most of them, being used even along with their Tajik synonyms, increasingly restrict the position of their Tajik equivalents such as: *azop* (pain), *g'am* (torment), *livos* (clothes), *miskin* (poor), *salla* (turban), *sal* (easy), *sof* (clean), *qalam* (pencil), *qafõ* (back), *surat* (view), *hayo* (shame), *haif* (sorry), *halol* (permissible), *quvvat* (strength), *shamol* (wind), *xammom* (bathhouse) etc. The usefulness of these words contributed to their formation with Tajik words of synonymous pairs: *damu nafas* (time), *sharmu hayo* (shame), *kuchu quvat* (strength).

Along with the words mentioned above, it is possible to find lexical elements that do not have synonyms, and if they do, then their Tajik synonyms are not used in the dialect. For example, *araq* (sweat), *doyira* (tambourine), *ishtiya* (appetite), *mashq* (exercise), *meros* (heritage), *mukofot* (prize, gift), *musulmon* (Muslim), *mo'khlat* (term/time), *namoz* (prayer), *nasiya* (non-cash), *nikoh* (marriage), *nuqra* (silver), *savun* (soap), *sil* (illness) etc. The part of the Arabic vocabulary, in the vocabulary of this dialect, also uses in the formation of words: *azo* (mourning), *azodor* (a person in mourning), *azodory* (mourning), *azo doshtan* (to wear mourning); *azob* (torment), *baazob* (tormenting), *beazob* (untorment) *beayb* (perfect), *aybdor* (guilty), *beaib* (innocent); *doira* (tambourine), *doyrachy* (play on tambourine), *dimog* (nose), *dimog'ash* (defunct); *zot* (breed), *zoty*

(breeding) etc. The number of words of the second group is also quite impressive, because the Arabic vocabulary has its own orthoepic-articulatory specificity. The speaker needs to practice a lot for their correct pronunciation. But dialects in this respect are more free. Hence, some Arabic loans undergo sound changes. The following phonetic phenomena are striking in this case: a) metathesis (replacement of sounds in places): *duyno-dunyo* (peace); *qulf-qufl* (amok)z, b) alternation of consonants: *aksa-atsa* (sneezing), *livos-libos* (cloth), *g'urvat-g'urbat* (quarrel), *maylis-majlis* (meeting), *nakht-naqd* (cash), *mashrafã-mashraba* (bottle), *isrif-isrof* (extravagance); c) loss of sounds: *nal-na'l* (horseshoe), *dafa-daf'a* (sequence), *makru-makro'h* (unclean), *lal-la'l* (ruby); d) adding sounds: *kift-kif* (shoulder), *etiyot-ehiyot* (carefully), *atir-atr* (perfume). The words which are included in the third group, having completely or partially lost their primary meaning, are used to express other meanings: *izolat* (troubles, torment, deprivation) *izolat* (remove, destroy); *kasophat* (ill-fated, unfortunate, unhappy, bringing misfortune), *kasophat* (pollution, dishonesty, ill-fated, ill-fortune); *mador* (strength, healing), *mador* (earth rotation line, base); *mazoq* (mockery, insult), *mazoq* (joke, prank, wit); *sal* (a little, a little), *sahl* (easy, a little) etc. Due to the fact that alien elements are constantly in a state of transformation after penetrating into the Tajik dialects which were noted above as a phenomenon testifies. The words of the fourth group, adjacent with the Tajik words, such a phenomenon as metaphor and assimilation, acquire a new meaning such as: *davra* (determination of the age of the deceased), *davron* (happy and carefree life), *manzil* (grave), *isrof* (extravagance), *lahm* (boneless meat). Acquiring stylistic features, these lexemes, are mainly used for the purpose of demonstrating to the speakers the mastery of their speech and the ability to amaze the interlocutor with expressive words. The fifth group consists of word-formation bases. The Arabic loans in the dialect are likened to word-formation norms and grammars of the Tajik language: create complex and composite elements adding prefixes and suffixes, form derivative words, joining to the Tajik roots: a) with the prefix *be-*: *bekafã* (fig. poor); b) with the suffixes *-chy*, *-y* and *-mand*: *g'ayvatchy* (gossip), *lozimy* (fig. pants), *dalloly* (mediation), *ayolmand* (large family). The Arabic loans as a word-formation basis, together with Tajik words, formed complex dialectisms: *maktabkhon* (pupil school), *araqchin* (light male headdress), *nashakash* (drug addict). The Arabic lexemes, connecting with Tajik auxiliary verbs, act as the main part of the compound nominal predicates: *aloqa kardan* (intimate relationship), *hayf shudan* (to lose something), *tamom shudan* (to die; fig. to get tired very much), *qalam kardan* (to break



into small pieces), *zarb kho'rdan* (hurt yourself) and the like. This kind of stems can also be observed in complex words of a mixed type: *maslihatoshy* (an event held before the wedding) etc. Arabic vocabulary mainly serves to express various concepts of the life of the population.

3.2. THE UZBEK LOAN

The problem of the mutual influence of the Tajik and Uzbek languages to some extent found its solution in the works by V.S.Rastorgueva, O. Dzhulolov, Q. Saidova, B. Niyozmukhammadov, Kh. Khamrogulov, M. Eshniyozov, T. Maksudov, M. Makhmudov, J. Muruvvatov, N. Sharopov. The most significant researches of V. S. Rastorgueva and J. Muruvvatov in this aspect. In particular, V.S.Rastorgueva, comparing the areas inhabited by Tajiks in Uzbekistan, gives a high assessment of the stability of the vocabulary and grammatical structure of the northern dialects of the Tajik language. About this feature, using the example of dialects of the Tajik language of the Andijan region, where the influence of the Uzbek language is especially strong, J. Muruvvatov writes the following: "According to the opinion of some researchers, various morphological elements of the Turkic-Uzbek language and its vocabulary could weaken the position of Tajik synonyms in dialects of the Uzbek language, but this did not happen. Conversely, during this time, dialects of the Tajik language, enriched by the Turkic-Uzbek words and phrases, developed according to their own internal regularities" (18). It is no secret that the morphological structure of a language, being very stable, always resists alien elements. The relationship of proximity between the Tajik and Uzbek (peoples) became the reason that Uzbek words penetrated into the Tajik language despite the long cohabitation. This phenomenon is felt in the northern dialect to some extent more, in the southern dialect relatively less, and even less in the central and southeastern dialects. The Uzbek vocabulary depending on the semantics and topics, is classified as follows in Samarkand dialect of the Tajik language:

1. Proper names, terms of relationship and properties: *O'g'uloy*, *To'khta*, *yangamulo* (wife of a brother or uncle), *oyti* (sister) etc.

2. Toponyms and ethnotonyms: *Oqmachit*, *Oqbuyro*, *Oghalik*, *Kelinchak*, *qishloq* etc.

3. The names of organs and parts of the human body: *suyak* (bone), *miya* (brain) etc. The words *qavurg'a* (rib) and *qosh* (eyebrow) refer to this group and have a general Tajik character. The lexeme *qavurg'a* has taken root in the vocabulary of the dialect so much that it does not even have its own Tajik synonym, the word *qosh* in the meaning of *abro*(eyebrow) has an advantage over its Tajik synonym.

4. The names of clothing, parts of it, household utensils and other items: *to'qquz* (bride's dowry), *qumg'on* (copper dishes), *qalmoq* (fishing equipment), *qapqoq* (lid), *kanor* (large bag for wool and wheat) etc.

5. The names of animals and birds: *buqqa* (bull), *qo'shqor* (sheep), *qaldirg'och* (swallow), *o'rdak* (duck) etc.

6. Food names: *qavurdoq* (fried meat), *qazy* (sausage horse meat), *qurut* (cheese, dried in the form of balls), *suyo'q* (liquid dishes) etc.

7. The names of fruits, vegetables and various plants: *ko'kcha* (variety of green sweet melon), *qairag'och* (barren tree), *qarolu* (black plum), *qo'ziqorin* (a type of edible mushroom) etc.

8. The geographical concepts: *cho'l* (steppe), *qir* (hill), *quduq* (well), *soy* (river) etc.

9. Abstract concepts: *qiliq* (trick), *sevanchy* (reward for communicating the good news), *jo'rta* (on purpose) etc.

10. The names of diseases: *yara* (wound), *yag'ir* (purulent wound) etc.

11. Together with Tajik verbs, they designate the concepts of action and attribute: *o'yla kardan* (to think), *davush dodan* (to notify), *tekis kardan* (to align) etc.

It should be noted that the Uzbek vocabulary in terms of distribution and degree is not the same of use in Samarkand dialect of the Tajik language. Part of the Uzbek vocabulary has a common feature, the other part from the point of view of expressing dialect concepts is found only within the framework of the studied dialect. Depending on this, this vocabulary can be classified as follows:

11.1. The common words that do not have synonyms in this dialect: *qaychy* (scissors), *qavoq* (eyelid), *bo'khcha* (knot with things), *qurut* (cheese dried in the form of balls), *qimiz* (kumis), *qazy* (horse meat sausage), *quloch* (girth), *yo'rg'a* (the other way), *yol* (mane) etc. These lexical elements, occupying a stable position in the vocabulary of the dialect, can acquire metaphorical and stylistic features: *qaymoq* (cream; fig content of speech, essence of conversation), *qayroq* (whetstone; fig. greedy) etc.;

11.2. The lexemes that have synonyms in the dialect and are used in parallel: *ayron* (*ayran*, liquid milk from sheep's milk), *ezma* (shameless), *jo'rta* (intend), *o'yla* (thought) etc.;

11.3. The words used as loan dialects, acquiring a figurative meaning in Samarkand dialect of the Tajik language, begins to possess polysemic and stylistic features: *urug'* (plant seed; breed and species; fig. descendants) etc.;

11.4. The words corresponding to the derivational models of the dialect serve as a basis for creating new meanings: *hamteng* (peer), *kattagy* (arrogance;), *erkatulfor* (spoiled) etc.



The facts which are mentioned above indicate that “the Turkic-Uzbek vocabulary has predominantly retained its original sound form” (66). However, there are many cases of their phonetic change: *sovluq* (sheep), *yirtish* (pieces of cloth handed out at funerals) etc. The Uzbek affixes do not participate at all in the formation of new lexical units in Samarkand dialect. Sometimes the words are used in the local form such as: *oylik* (salary), *kurgan ko'rishgan* (general greeting) etc. The Uzbek vocabulary is mainly used at the same time to concretize concepts and events that took place in Samarkand dialect. The most of the words in this dialect have been mastered in the process of acquiring polysemantic and stylistic features by them indicates. Hence it follows that the Uzbek loan into the lexical composition of the dialect is considered a natural and obligatory phenomenon and contributes to the enrichment of the vocabulary.

3.3. THE RUSSIAN-EUROPEAN LOAN

The Russian-European vocabulary and the ways of using into the modern Tajik language are examined in the monographs of N. Sharofov. The Russian-European lexemes are used in the following forms, as in other dialects of the Tajik language in Samarkand dialect:

- 1) without phonetic change;
- 2) with sound change;
- 3) as a derivational basis in the composition of derivatives, complex and compound words;
- 4) in a figurative sense.

The important factors of the Russian-European loans into the vocabulary of the language is that they do not have their own dialect synonym or the use of similar vocabulary in comparison, contributes to the reflection of the concept of a specific object or phenomenon with their Tajik equivalent, having an advantage in any respect. From the point of view of meaning and subject matter, such lexemes belong to different branches of human life:

- 1) The name of the types of equipment: *poyiz* (train), *tilishka* (light cart), *tiliphone* (telephone) etc.;
- 2) Job titles and professions: *nachaylik* (chief), *pirakuror* (prosecutor), *so't* (judge), *zafkhos* (manager), *birgad* (foreman), *bug'altir* (accountant) etc.;
- 3) The names of public institutions: *turma* (prison), *zavut* (factory), *intirnat* (boarding school) etc.;
- 4) The names of clothes and shoes: *buruk* (trousers), *kastum* (suit), *patinka* (boots), *kalosh* (galoshes) etc.;
- 5) The names of culinary products: *bo'lushka* (bun), *picini* (cookies), *praynik* (gingerbread) etc.;

6) The names of household items: *misarupka* (meat grinder), *skavarotka* (frying pan), *dukhovka* (oven), *haladilnik* (refrigerator) etc.;

7) The names of dwellings and its parts: *cherdak* (attic), *viranda* (veranda), *kalidor* (corridor) etc.;

8) The various concepts: *padarka* (gift), *odikh* (rest), *prava* (driver's license), *znak* (sign), *nomir* (number), *poviska* (notification), *ispravka* (reference/information) etc.;

9) The Russian lexemes with Tajik auxiliary verbs form combinations and are used in a figurative sense: *krishta raftan* (mentally ill), *knishka doshtan* (mentally unbalanced), *peshka shudan* (to be a fool), *pavestka omadan* (approaching death) etc.;

10) They are used as derivational bases for the formation of derivatives, complex and compound words, free and phraseological phrases: a) to create derivative words: *tabilchy* (bookkeeper), *shofiri* (driver), b) to form compound words: *milsahona* (police office), *kastumfuro'sh* (suit seller); c) for the formation of complex, mixed words: *papiroskashy* (smoking), *araqkho'ry* (drinking); d) in the formation of compound nominal verbs: *raport dodan* (to report), *odikh kadan* (to rest); e) to create phraseological combinations: *gazit khondan* (nothing to do), the current is set (sober up/become) etc.

The Russian-European loans are used in various spheres of social life of the population and reflect the political, economic, technical and cultural changes that have occurred in Samarkand dialect in this respect. Along with the acquisition of a useful property, are assimilated in dialectal speech, serve to express the subjective and stylistic properties of speech.

4. CONCLUSION

In conclusion the facts which were noted/mentioned above, the lexical layer of Samarkand dialect, in addition to the original Tajik words, has a lot of loaned vocabulary, which during the historical period entered the lexical fund of the Tajik language and enriched it with Arabic, Uzbek and Russian-European words. Thus, the Uzbek vocabulary dialect is mainly used in order to concretize the concepts and the events that took place in Samarkand, and it follows that the inclusion of loans in the lexical composition of the dialect is considered a natural and obligatory phenomenon and contributes to the enrichment of its vocabulary. The most of the words in this dialect have long been learned and are used as their own words in the process of acquiring polysemantic and stylistic features. Thus, loans and/or borrowings are used in various spheres of the social life of the population and reflect the political, economic, technical and cultural changes that have taken place, and thus are



mainly used in order to concretize concepts and events in Samarkand dialect.

REFERENCES

1. Abdulloeva G.Z. *Lexicon of the Karatag dialect: PhD dissertation. Candidate of philological Sciences: 10.02.22 / Gulrukhsor Ziyodulloevna Abdulloeva. - Dushanbe, 2013. - p. 22*
2. Atobulloyev S. *Southern dialect of the Tajik language (in Tajik) / S. Atobulloyev. T. 4. - Dushanbe: Donish, 1984. - p. 252*
3. Behbudi N. *Speech of Samarkand Tajiks. Moscow, 1956.*
4. Davronova M. *Vocabulary of theft in the Tajik dialect of Samarkand. "Problems of Tajik Linguistics" Samarkand, 2002*
5. Dzhuraev G., Gaffarov R. *The area of dialects of the Tajik language (in Tajik) / G. Dzhuraev, R. Gaffarov // Soviet School, 1969, №6. pp. 24-29.*
6. Gadoev N. *Vocabulary of the Tagnov dialect / N. Gadoev. -Dushanbe: Irfon, 2012. - p. 209*
7. Gaffarov R. *Southern dialects of the Tajik language (in Tajik). T. 3 / R. Gaffarov. - Dushanbe: Donish, 1979. - p. 215*
8. Grigoriev V. V. *About some events in Bukhara, Kokand and Kashgar / V. V. Grigoriev. - Kazan, 1861 (reprinted in 2011). - p. 163*
9. Ismoilov Sh. *The vocabulary of the Karategin dialect: PhD dissertation. Candidate of philological Sciences: 10.02.22 / Shamsullo Ismoilov. -Dushanbe, 1982. - p. 24*
10. Juraev Sh. *The relationship of Tajik and Uzbek languages. Author of the dissertation for the degree of Doctor of Philosophy (PhD) in Philology Samarkand, 2018*
11. Kosimov V. *On the professional vocabulary of the dialects of the Tajiks of Samarkand (vocabulary of carpenters and stonemasons) Abstracts Samarkand, 1971*
12. Kuznetsov P.E. *Comparative grammatical sketch of Tajik and Sart dialects / P.E. Kuznetsov. "News of the Turkestan department. Russian Geographical Society". T. Kh., №2, part 1. - Tashkent, 1915.*
13. Khonkhujaeva A. *Ethnographic lexicon of the Tajik language on weddings and mourning ceremonies (based on Samarkand dialect), Samarkand, 2019*
14. Masudov T. *Vocabulary and phraseology of dialects of Tajiks in Isfara (in Tajik) / T. Masudov. -Dushanbe: Irfon, 1977. - p. 160*
15. Muruvvatov J. *About the relationship of the Tajik and Uzbek languages (in Tajik) / J. Muruvvatov // Questions of Tajik dialectology (scientific collection). Tashkent. - Dushanbe: Donish, 1970. pp. 258-274.*
16. Nazarova L. *Some word-formation suffixes of the Samarkand Tajik dialect group "Problems of word-formation in the Tajik language" Samarkand, 1991*
17. Nemenova R.L., Dzhuraev G. *Southern dialects of the Tajik language (Phonetics, vocabulary) / R.L. Nemenova, G. Dzhuraev. T. 1. - Dushanbe: Donish, 1980. - p. 331*
18. Osimova B.A. *Khojent dialect (Vocabulary and phraseology) / B. A. Osimova. - Khuchand: MMPI, 2000.- p. 56*
19. Rastorgueva V.S. *Feature article on Tajik dialectology / V.S. Rastorgueva. Issue 5. Tajik-Russian dialect dictionary. - Moscow: Ed. AN SSSR, 1963. p. 250*
20. Rastorgueva V.S. *Experience of comparative study of Tajik dialects / V.S. Rastorgueva. - Moscow: Nauka, 1964. - p. 188*
21. Sanginova R. *Lexicon of the Kanibadam dialect of the Tajik language: PhD dissertation. Candidate of philological Sciences: 10.02.22 / R. Sanginova. - Dushanbe, 2012. - p. 23*
22. Semyonov A.A. *Material for studying the dialect of mountain Tajiks of Central Asia / A.A. Semyonov. Part 1. -Moscow, 1900.- p. 56*
23. Sharofov N. *Russian-international words in the Tajik literary language (in Tajik) / N. Sharofov. -Dushanbe, 1972. p. 162.*
24. Uzbekov S. *Lexicon and phraseology of the Andarak dialect of the Tajik language: PhD dissertation. Candidate of philological Sciences: 10.02.22 / S. Uzbekov. - Khujand, 2009. - p. 24*
25. Vohidov A. *Some thoughts on a method of formation of some toponyms of Samarkand "Problems of Tajik linguistics" Samarkand, 2002*
26. Vohidov A, Khochimatoeva Z, Davronova M. *"Treasure of Samarkand" Samarkand, 1997*
27. Yusufov H. *The use of folk colloquial Uzbek words in the works of S. Ayni / H. Yusufov // Scientific collection of the Kulyab State Pedagogical Institute named after Rudaki. - Kulyab: KSPI named after Rudaki, 1969. pp. 146-169.*
28. Zamonov Z. *Lexicon of the Dashtidzhum dialect: PhD dissertation. Candidate of philological Sciences: 10.02.22 / Z. Zamonov. - Dushanbe, 2009. - p. 19*
29. Zokhidov A. *Ethnography of marriage in the Tajik style of Samarkand and Bukhara. "Problems of Tajik linguistics" Samarkand, 2002*



TRANSLATOR'S ACTIVITY AND KNOWLEDGE BASE IN LITERARY TRANSLATION

Khalilova Olima

*Senior teacher of the Foreign Languages Department, Karshi Engineering-Economics Institute,
Karshi City, Uzbekistan*

Abdirakhimova Mokhigul

*Senior Teacher of the Foreign Languages Department, Karshi Engineering-Economics Institute,
Karshi City, Uzbekistan*

Article DOI: <https://doi.org/10.36713/epra5687>

ABSTRACT

Translation skills are the most important part of translation and can complement the other two. If the translator does not have enough knowledge and experience, it will be difficult for the translation to be complete. If these two qualities are sufficient, he can use creative methods to translate even a low-level work in a level view and fully meet the needs of the customer.

KEYWORDS: *translation, process, knowledge base, grammar translation linguistic activity, inter linguistics, inter lingual, speaker, content.*

DISCUSSION

The analysis of the cognitive features of the translation process requires the identification of the conceptual foundations of the translation activity, without which the ability to interpret the facts of the field collected over a long period of time is lost. One of such conceptual bases is, of course, that the activity of translation depends on the knowledge base, because every rational action is carried out within the existing knowledge. The accumulation of knowledge is a gradual process, it is difficult to acquire it urgently or involuntarily, it is mainly accumulated on the basis of knowledge, step by step. Even knowledge acquired through indirect means of information must pass certain tests to become a reality. . The work of an interpreter is one of the types of intellectual, step-by-step, intelligent activity.

On the first page of his 1965 book, J. Kathford, an English translator, suggested that translation be seen as an "Operation Performed on Languages" because in the process "a text in one language is confused with another." It is clear, he concludes, that the theory of translation must be based on a particular

linguistic theory or a general linguistic theory. It is worth joining the second part of Ketford's commentary, as it draws on translation studies, more precisely on language theory. It uses some analytical ideas based on its advanced methods.

But the inter linguistic alternatives of the texts do not seem to suggest that "the grammar and vocabulary of the original language are exchanged with the grammar and dictionary of the target language, and consequently the phonology of the two languages, the place of writing." Although we believe that the translation process consists of transformations, stages of inter lingual migration, it is difficult to say what happens to such a migration and how the migration takes place. It has become customary to interpret translation as the expression of the meaning of a text in one language in another. We all believe in this belief. At the same time, we have always witnessed how difficult it is to preserve meaning [1, p. 4].

The well-known Edward Sepir hoped to emphasize that in the 1930s there was no possibility of translating literary texts, and that the possibility of



scientific translation was explained by the existence of "some common language without outer garments" in the statement of scientific facts. According to him, "a word is a form that is sometimes more or less mastered from the conceptual material of thought, depending on the spirit of a particular language." Describing the word only as a phenomenon with a form, E. Sepir considers the part of its emotional meaning to be devoid of linguistic value. Even the emotional meanings of the English words storm-thunder, tempest- storm, hurricane- hurricane can not dissuade the scientist from his own opinion, and in his opinion, "the emotional tone of the word is useless for science." It is also surprising that in the end, artists are advised to "find ways to get rid of the emotional tones that cling to words and return them to a purely conceptual meaning".

Who doesn't know that art is directly related to psyche, emotional expression !? As the French literary critic J. Sartre put it, "the language of art knows no boundaries, it evokes the senses of taste and smell" [2, p. 6].

In fact, the creators choose the words according to their feelings and thoughts, at a level that evokes the necessary imagination in the students. As Alisher Navoi wrote in *Muhokamatul-lug'atayn*, and the first two of them mean "secretly weeping with pain," and the last one is an exaggeration of weeping.

Is it possible to ignore the subtleties of meaning? When the meaning consists only of a reference piece, it is inconceivable that the word could, in the words of Alisher Navoi, "enchant and decorate the imagination." The emotional-spiritual part of the meaning plays an important role in the formation of the aesthetic content of the text. Moreover, this part is expressed in each language in its own way, because the different worldviews and attitudes of people of different cultures and nationalities can rarely match. Even when writing a text about a single event, attention is paid to the indicators of specific situations in different languages. These indicators have a cultural significance, but sometimes they also depend on the characteristics of the language system. A simple example: the English and Uzbek "I've arrived" and "I came" structures are almost equally valuable and can be easily considered as equivalents. However, translating these structures into Russian poses some difficulties.

In translation studies, there are a number of theories aimed at determining the adequacy of translation, sorting translations, and providing a scientific and theoretical assessment of the translator's skills. Theory, on the other hand, is naturally updated and enriched by modern theories over time. One of the theories in this new direction is the theory of cognitive dissonance. The essence of this theory is to identify adequate translations, to study the causes of the factors that hinder the

achievement of adequate translation, and to find ways to reduce and eliminate them as much as possible in the translation process. Before defining the problem of cognitive dissonance that underlies this theory and its place in literary translation, it is necessary to study the essence of this phenomenon.

Cognitive linguists prefer to approach the interpretation of the phenomenon of meaning in terms of the activation of linguistic units of semiotics in the context. At the heart of this interpretation is the idea that meaning is a content that can be understood in an environment of direct activation, rather than a "innate" heritage of language unity. Of course, the role of linguistic elements in speech structure is significant. This share alone is not enough to understand. The conceptualization of reality comes to the fore here. In the same context, the speaker forms the semantic content of the thought, emphasizes the important aspects of the participants of the speech structure, adapts it to the accepted worldview. In this sense, it seems more plausible to interpret meaning in the interpretation of a text or other linguistic unit as an event that is created as a result of cognitive actions performed by the user of the language, rather than a ready-made whole. In that case, it is more appropriate to suggest that the activity of translation also arises from the practice of re-creation in a new environment or context, rather than from the practice of transferring meaning from one language to another.

LIST OF USED LITERATURE

1. Ziyadullayeva. U. *The problem of cognitive dissonance in literary translation. Samarkand.2020. P-34-41.*
2. Catford J.C. *A Linguistic Theory of Translation; An Essay in Applied Linguistics. Oxford: OUP, 1965.P-4;*
3. Sartre J.P. *What is literature? – Harvard: Harvard Univ. Press, 1988. P-6;*
4. Rivers, Wilga. *Teaching Foreign Language Skills. Chicago: University of Chicago Press. 1968, 62-72 p.*
5. Richards, J. C., and Rogers, T. S. *Approaches and methods in language teaching: A description and analysis. Cambridge: CambridgeUniversity Press. 2001, 87-97 p.*
6. Brown, H. Douglas. *Teaching by Principles: An Interactive Approach to Language Pedagogy, Second edition. New York: Addison Wesley Longman, Inc. 2001, P-97.*
7. Halliday, M. A. K. *Spoken and written language. Oxford: Oxford University Press. 1989, -31 p.*
8. M. Erkinova. *Audition as a method of boosting of a level in the English language. Samarkand. 2020. P-8-16.*



METHOD DEVELOPMENT AND VALIDATION BY RP- HPLC METHOD FOR CILOSTAZOL IN BULK AND TABLET DOSAGE FORM

Miss.Chavan A. S*

*Department of Quality Assurance, School of Pharmaceutical Sciences, Sandip University,
Nashik – 422002, Maharashtra, India*

Dr. Derle D. V

*Department of Quality Assurance, School of Pharmaceutical Sciences, Sandip University,
Nashik – 422002, Maharashtra, India*

Dr. Gulecha V.S

*Department of Quality Assurance, School of Pharmaceutical Sciences, Sandip University,
Nashik – 422002, Maharashtra, India*

Miss. Deore S. V.

*Department of Quality Assurance, School of Pharmaceutical Sciences, Sandip University,
Nashik – 422002, Maharashtra, India*

*Corresponding author

ABSTRACT

The aim of the present work is to develop an accurate, precise, and cost effective RP-HPLC method for the determination of Cilostazol in bulk and pharmaceutical dosage form. Separation was done with a column Chemsil ODS C₁₈, (250mm × 4.6 I.D; particle size 5µm) at R.T. at a flow rate 1.2ml/min using the mobile phase methanol: water pH 3 (85:15 v/v) at an wavelength 257nm with an chromatographic run time 10 min. The method was linear over the range of 2-10 µg/ml with correlation coefficient of 0.9993 for Cilostazol.

KEYWORDS : *Cilostazol, RP-HPLC and validation*

INTRODUCTION

Cilostazol is a quinolinone derivative and antiplatelet agent with vasidilating properties that has been used in the symptomatic treatment of intermittent claudication in patient with peripheral ischaemia. Is used to improve the symptoms of certain blood flow problem in the legs. Cilostazol is chemically known as 6 - [4 - (1- cyclohexyl -1H -

tetrazol - 5 - yl) -butoxyl] - 3,4 dihydro - 2(1H) - quinolinone.

The present RP-HPLC work was more effective than other methods for estimation of Cilostazol drug in tablet dosage form because require less time ,less sample volume, done at an ambient temperature etc.

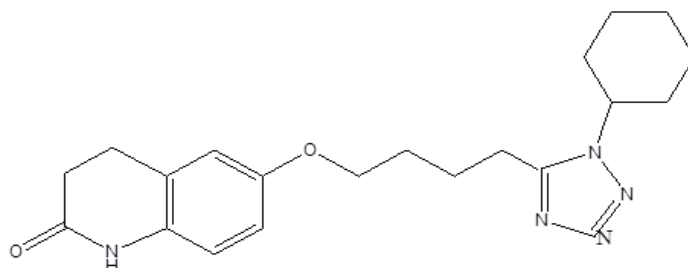
**Structure****Table no 1 : Properties of Cilostazol drug**

Sr. no.	Physical properties	Reported result
1	Colour	White or off white
2	Odour	Odourless
3	Appearance	Crystalline
4	Melting point	159.4- 160.3°C
5	Category	antithrombotic

MATERIALS AND METHODS**Materials**

Cilostazol was a gift sample from pure chem India. Cilostazol tablet used were Slitoz 50mg, Glenmark pharmaceuticals. HPLC grade methanol, water, orthophosphoric acid, from Modern lab, Nashik.

Instruments

Waters corp HPLC, column chemsil ODS C₁₈, UV – visible detector, manual inject port, breeze software, precision balance, digital pH meter, Digital ultra sonicator.

Preparation of Mobile Phase

The 10mM orthophosphoric acid was prepared and pH adjusted to 3 and filtered through nylon filter paper and mixed with methanol : water in the volume ratio of 85:15 v/v and sonicated for 15 mins to degas the mobile phase.

Preparation of Standard Stock Solution

25mg Cilostazol was accurately weighed and transferred into 25 ml volumetric flask make up the volume up to the mark with the diluent to obtained concentration 1000µg/ml. through this solution prepare further dilution.

Test solution preparation:

Take twenty tablets, each containing 50 mg of Cilostazol . The tablets were extinguished to small powder and quantity of powder parallel to 50 mg of Cilostazol were measured and added in 25 ml volumetric flask make up with methanol and shaken to make transparent solution. The solution was flow by using membrane filter and degassed. From this solution pipette out 2ml transfer in 10ml volumetric flask and fill up to the signal by utilizing methanol as solvent to get 200µg/ml solution.

VALIDATION PARAMETERS**A) Linearity:**

Unknown conc. reports that are parallel to the concentration of analyte in samples within a given limit known as linearity.

Determination

Take 6 different concentration and each take 3 replicate. Prepare graph conc. Vs. Area and calculate correlation coefficient and %RSD

B) Accuracy (%Recovery):

The belonging of unknown conc. solutions reports obtained by that method to the observed value is known as accuracy. The % recovery checked by add known conc. of STD solution against test solution .

C) Precision:

The number of test solutions of a same sample giving same results known as precision. Through this calculated SD and RSD

Method for precision:**Determination:**

Take either 3 different conc. and each take 3 replicate or take 6 replication of same concentration and calculate precision

D) Robustness:

It is the quantitate of capacity of the method to unchanged by little but intentional difference in method framework and provides an signal of its constant under normal usage.

Determination:

Quantitated by changing different variable which effect on method performance in within limit.

The unknown conc. solution and known conc. solution was injected under variable chromatographic state as shown below.

E)Limit of Detection:

The lower conc. of the analyte in the sample that the method can found but not necessarily measured



under the given experimental state simply shows that the sample is below or above certain range. Limit test prescribed as percentage or as parts per million. The limit of detection will not only depend on the procedure of analysis but also on type of instrument.

Limit of Quantitation:

The lowest conc. of test sample can be measured under the given experimental conditions. The S/N ratio should not less than 10 and RSD \leq 2%.

RESULT AND DISCUSSION

**Fig no. 1: Calibration curve for Cilostazol in methanol:water
(λ_{max} = 257nm)**

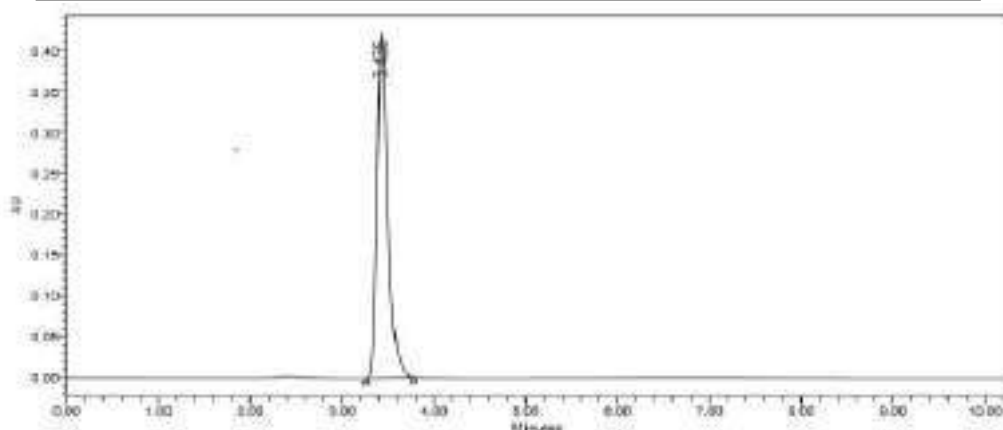
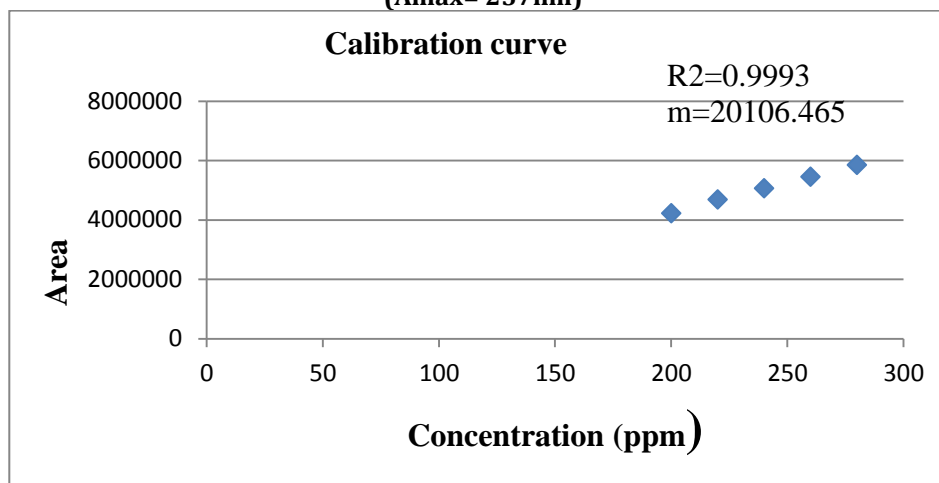

Fig no. 2 chromatogram of Cilostazol

Developed Method

Mobile Phase Composition: Methanol : Water (85:15)	Flow Rate: 1.2 ml/min
Temperature: ambient	pH : 3 (adjusted by 10mM orthophosphoric acid)
Column name: Chemsil ODSC18 (250 x 4.6 mm, 5.0 μ m)	Tailing factor : 1.40
Injection Volume : 10 μ l	Wavelength: 257nm
Program : Isocratic	Plate count : 4393
Detector: Ultraviolet	Retention time : 3.4 min.

System suitability test for Cilostazol:

The plate count, tailing and %RSD was found to be within limit.

Plate count – more than 2000, tailing less than 2 and %RSD less than 2.

**Table no 2: Results of Method Precision of Cilostazol**

Sample Name	Retention Time (min)	Area	Plate count	Tailing
Stand.1	3.442	4395598	4432	1.40
Stand.2	3.396	4359222	4426	1.41
Stand.3	3.432	4418208	4439	1.40
Stand.4	3.372	4415373	4345	1.40
Stand.5	3.379	4403955	4349	1.40
Stand.6	3.579	4398574	4367	1.40
Mean	3.428	4398488	4393	1.40
S.D	0.05723	9495.36	25.807	0.002
%RSD	1.66	0.21%	0.587	0.14

Validation

Linearity : correlation coefficient was found to be 0.9993 (NLT 0.999) and %RSD less than 2.

Table no 3: Results of Method Precision of Cilostazol

Sr. no.	Conc. (µg/ml)	Area (avg.mean)	%RSD
1	200	4412512	0.12
2	220	4685763.6	0.053
3	240	49027856	0.71
4	260	5449454.6	0.64
5	280	5845392.3	0.012
Correlation coefficient (R ²) = 0.9993			

ACCURACY:

The recovery of drug was found to be 98 to 102% within std. limit.

Table no 4: Results of Method Precision of Cilostazol

Cilostazol							
Sr. No.	Conc. Level	Conc. (µg/mL) STD solution	Conc. (µg/mL) tablet solution	Area	SD	%RSD	% Recovery
1	80%	1	1.4	4685892	1879.10807	0.04	100
		1	1.4	4683527			
		1	1.4	4688832			
				Mean - 4686083.6			
2	100%	1.4	1.4	4868273	1412.9874	0.02	99.25
		1.4	1.4	4865832			
		1.4	1.4	4864312			
				Mean- 4866139			
3	120%	1.6	1.4	5450304	8774.9913	0.16	99.7
		1.6	1.4	5433024			
		1.6	1.4	5426235			
				Mean- 5436521			



Precision : The %RSD was found to be less than 2%.

Table no 5: Results of Method Precision of Cilostazol

Sr. No.	Concentration (µg/ml)	Area	RT (min)	Inj.Vol. (µl)	TPN	TF
1	240	4868289	3.435	10	4482	1.40
2	240	4865834	3.345	10	4320	1.40
2	240	4863818	3.391	10	4321	1.40
4	240	4866254	3.345	10	4432	1.41
5	240	4868863	3.435	10	4420	1.40
6	240	4863988	3.444	10	4373	1.40
Mean		4866173.6				
SD		938.355				
%RSD		0.01928				

Robustness

The given method was show same efficiency when changing a small parameter like a change in flow rate, change in mobile phase etc.

Effect of variation in flow rate
Change in flow rate – ± 0.1 ml/min

Table no 6: Results of Method robustness of Cilostazol

Sr. No.	System Suitability parameter	Observations			Limits
		1.1ml/min	1.2ml/min	1.3ml/min	
1	peak area response	4868289	4863814	4767482	
2	Theoretical plates	4392	4367	4390	NLT 2000
3	Tailing factor	1.40	1.40	1.39	NMT 2.0
4	Retention Time (Min)	3.391	3.436	3.436	

LOD and LOQ :

Table no 7: Results of Method LOD and LOQ of Cilostazol

Drug name	Correlation Coefficient (R ²)	Slope (s)	LOD (µg/ml)	LOQ (µg/ml)
Cilostazol	0.9993	20106.465	0.15400µg/ml	0.46669µg/ml

Assay

The given method and validated method was applied to the determination of cilostazol in marketed

tablet containing 50mg of drug per tablet. The std limit of assay 98 to 102 %. The given method was show result within assay limit.

Table no 8: Results of Method Precision of Cilostazol

Name	Std sample Peak Area	Tablet sample peak Area	Assay(%)
Cilostazol	4854224	4865834	100.2%



CONCLUSION

The developed method was validated according to ICH Q2R1 guidelines. The developed method was simple, robust and its an cheap method than others method. The given method efficiency was good i.e plate count no. more with short retention time, less tailing i.e. with sharp peak. And also the method give results(%RSD Less than 2, taliling less than 2 and Regression NLT 0.999) within in limit, Hence this method are useful for separation of Cilostazol drug in pure and tablet dosage form.

REFERENCES

1. *The Merck Index-an Encyclopedia of chemicals, drugs, and biologicals. published by MERCK and CO; INC white house station, 2001;13: 2300.*
2. *Indian Pharmacopoeia, Government of India Ministry of Health and family welfare. published by Indian pharmacopoeial commission Ghaziabad 2014; 2:1393-4.*
3. *J.J.Jyoti, Haque A.M.D, Islam S.M.A, Islam M.S. Validation and Optimization of a simple RP-HPLC method for determination of cilostazol in Human serum. Indian journal of novel drug delivery 2011;3(2):143-48.*
4. *Suresh and Rambabu. Isocratic Reversed phase Liquid Chromatographic method validation for the determination of Cilostazol in pure and formulation. International journal of pharmacy and pharmaceutical research 2015; 4(3):180-92.*
5. *International Conference on Harmonization Harmonised Tripartite guideline, Q2(R1) Validation of analytical procedures:Text and methodology 2005.*
6. *M. Swapna, M. Vijay, M. Sunil. RP-HPLC method development and validation for Cilostazol in tablet dosage form. International journal of pharmacy and analytical research 2016; 5(4):579-84.*
7. *Kurien J and Jayashekhar P. Stability indicating HPLC determination of Cilostazol in Pharmaceutical dosage form. Internatinal journal of pharmaceuticals and biosciences 2014; 5(1):176-182.*
8. *Kilaru N.B, Javvaji M.K, Vallaru R.K,Chinnala K.M. Development validation of RP-HPLC method for estimation of cilostazol in Pharmaceutical dosage form.International Journal of pharmaceutical biosciences 2015; 5(1):153-160.*
9. *Basniwal P.K, Kumar V, Shrivastav P.K, and Jain D Spectrophotometric determination of Cilostazol in tablet dosage form. Tropical journal of pharmaceutical research 2010;9(5): 499-503.*
10. *B. Lavanya, A. Elphine and N. Ramrao. Analytical method development and validation of Cilostazol in pharmaceutical formulation using RP-HPLC. International journal of pharmaceutical research and novel sciences 2014; 1(2):99-104.*
11. *Patil A. S and Pethe A.M. Quality by design: A new concept for development of quality pharmaceuticals. International journal of pharmaceutical quality assurance 2013;4(2):13-19.*



TELOMERE BIOLOGY: TELOMERE STRUCTURE, FUNCTION AND RELATED DISEASES

Ranjan Kumar¹

¹PhD Research scholar, School of Life sciences, Jawaharlal Nehru University, New Delhi-67

Deepika Bhardwaj²

² PhD Research scholar, South Asian University, New Delhi-21

Shikha Bharati³

³PhD Research scholar, School of Life sciences, Jawaharlal Nehru University, New Delhi-67

Manoj Kumar⁴

⁴ PhD Research scholar, School of Life sciences, Jawaharlal Nehru University, New Delhi-67

Article DOI: <https://doi.org/10.36713/epra5707>

ABSTRACT

Telomere is the special heterochromatin structure which caps the end of eukaryotic chromosome and ensures the faithful replication of genetic materials. It also provides the protection against DNA damage signals and ensures the genome integrity and stability. Telomerase complete its task by its unique nucleoprotein structure. Here in this paper detail about nucleoprotein structure and their function is included. Robustness of function of telomere across cell cycle is guaranteed by the interaction between telomere and its interacting proteins. Recent findings regarding telomere biology and cancer are also included in this paper.

KEY WORDS: *Telomere, DNA damage, cell cycle, cancer*

INTRODUCTION

Concept of telomere came in the existence before the elucidation of DNA double helix after Herman Muller and Barbara Mc Clintock findings. Muller used X-rays to fragment the chromosome and gave functional description of telomere. Both Herman Muller and Barbara McClintock working with fruit flies, and maize respectively made the same conclusion concurrently regarding natural end of chromosome. They concluded that natural end of chromosome is different from chromosomal break end. In 1938 term 'telomere' came in existence when Muller named the natural end of chromosome 'telomeres' (Muller, 1938). The word telomere came

from combination of two Greek words telos and meros, meaning *end* and *part* respectively.

Nobel prize in physiology and medicine in 1946 and 1983 were awarded to Muller and Barbara McClintock respectively. At that time due to lack of appropriate tools the molecular nature of telomere was unknown. Watson and Crick double helical structure of DNA reported in 1953 (Watson and Crick, 1953), suggests mechanism for its replication. In 1960s Arthur Kornberg discovered DNA polymerase which is responsible for DNA replication. After the discovery of DNA polymerase end replication problem in case of linear DNA came in light due to the inherent property of DNA polymerase's inability to replicate linear DNA to



completion (Kornberg, 1974). In 1975 Elizabeth Blackburn joined the laboratory of Joseph Gall at Yale after completing her Ph.D from Frederick sangers laboratory. She wanted to apply her knowledge of DNA sequencing to understand the molecular nature of chromosome termini. On sequencing the native ends of macromolecular ribosomal DNA of Tetrahymena, Blackburn found that they consist of non-coding 5'-TTGGGG-3' variable repeats which varies from molecule to molecule. Elizabeth Blackburn and Jack Szostak together performed experiment by adding DNA end of linear DNA from ribosomal DNA of Tetrahymena to artificial chromosome in yeast which protect it from degradation (Blackburn and Szostak, 1984). Blackburn with her graduate student Carol Greider discovered telomerase. In 2009 Elizabeth H. Blackburn along with Carol W Greider and Jack W Szostak were awarded Nobel prize in Physiology or Medicine for their work on protection of chromosomes by telomeres and the enzyme telomerase.

In this paper telomere, structure, function and its related diseases are discussed in detail. Telomere is a heterochromatin structure made up of telomeric DNA and proteins associated with telomere present at the end of chromosome. Its main function is maintaining the integrity of chromosome from preventing them from being recognized from ds DNA break repair system. The length of telomere is maintained by recruiting telomerase at the telomeric DNA. IT has TERT subunit which act as reverse transcriptase and has TERC subunit which acts as template for addition of telomere. Telomerase has many non-telomeric function also like RNA dependent RNA polymerase activity, regulation of gene expression, regulation of apoptosis and role in DNA repair. The protein complexes mainly shelterin interacting telomeric DNA provides stability to the chromosome, helps in recruitment of telomerase and regulates length of telomere. Telomere length is regulated by telomerase, components of shelterin complexes and epigenetic regulation. Any defects in telomere regulators causes telomere related diseases.

1. TELOMERE

Special heterochromatin structure capping the ends of eukaryotic chromosome helps in maintaining the structural integrity and ensures complete replication of the ends of eukaryotic chromosome. These caps prevent the loss of genetic material and prevent the recognition of DNA double strand break of chromosome by signalling mechanism associated with DNA damage (Karlseder et al., 2001; Artandi, 2006). It hinders the fusion of the chromosome end with neighbouring chromosomes (end to end fusion) and degradation which lead to cellular senescence or

even apoptosis. Telomeres arrange to form loop structure (T-loop and D-loop) which act as protective chromosomal cap.

2. MOLECULAR STRUCTURE OF TELOMERE

Telomeres are generally composed of DNA and multiple DNA binding proteins (Greider et. al., 1996; Wellinger and McElligott, 1997).

Telomeric DNA in mammals consists of TTAGGG in 5' - 3' and its complementary 3' AATCC 5' sequences followed by 3'G-rich single-stranded overhangs of 30-500 nucleotides long. This single-stranded 3'G-rich overhang is the telomeric end key feature in all organisms (Makarov et. al., 1997; Wellinger and McElligott, 1997). 5'C-rich single-stranded overhang is reported to be found in worms (Raices et. al., 2008) and also occurs in certain cancer cells transiently (Karlseder and Oganessian, 2011).

Telomeres shorten at each cell division and ultimately lead to critically short non-functional telomeres which further leads to replicative senescence (telomere dependent cell cycle arrest). This shortening happens due to the inability of the replication machinery (DNA polymerase) to replicate linear DNA to completion. Telomere length can be maintained by two mode- (1) Telomere dependent, (2) recombination based system (Alternative Lengthening of Telomeres, ALT). But in dipterans telomere lengths are maintained by retrotransposons insertion to the chromosome ends (Mason and Biessmann, 1995; Mason et al., 2008).

3. TELOMEREASE

The telomerase is a unique ribonucleoprotein complex which resolves the problem of end replication by extending the ends of newly replicated chromosomes with telomeric repeats through its reverse transcriptase activity. Human telomerase consists of at least six subunits: - 1) human telomerase RNA component or hTERC; 2) human telomerase reverse transcriptase or hTERT; 3) heat shock protein 90 or hsp90; 4) telomerase associated protein or TEP1; 5) p23; 6) dyskerin. Among these six subunits, the core subunits are hTERC and hTERT. Rate limiting component of telomerase is hTERT as its expression level changes proportionately during up and down regulation of telomerase and rest of the components remains unchanged (Chang, J.T. et al., 2002).

3.1. TELOMEREASE RNA COMPONENT (TERC)

TERC is the RNA constituent of the telomerase holo-enzyme which is the template for telomeric DNA extension (Blackburn, E.H. and Greider, C.W., 1989). It is one among all those factors which influences the processivity of



telomerase. Human TERC gene is located on chromosome 3 and its locus is 3q26.3 (Feng, J. et al.,1995). Size of TERC varies among species. Size hTERC is 451 nucleotides (Blasco, M.A. et al.,1995). Telomerase RNA shows less conservation during evolution. It shows that between species, the primary sequence is diverse but secondary structure is remarkably conserved which indicates the importance of RNA structure in telomerase activity (Chen, J.L. et al., 2000).

3' end of the hTERC contains sequence motif of H/ACA and form a non-coding RNA specific class which facilitates the modification of other cellular RNA (Mitchell et al.,1999, Chen et al., 2000). These H/ACA RNA are divided into two groups on the basis of localization (nucleolus and Cajal bodies)- i) H/ACA small nucleolar RNA (snoRNA) accumulated in nucleolus, it participates in modification of ribosomal RNA (Mitchell et al., 2000). ii) Cajal body specific RNA (scaRNA) accumulated in Cajal bodies, it participates in the modification of splicing RNA (Matera et al., 2007). CAB or Cajal body box is another sequence motif responsible for different localization of snoRNA and scaRNA in the cell.

The accumulation, maturation and stability of hTERC depends on interactions of hTERC conserved domain with hTERC-binding proteins (La, hnRNP, dyskerin, hTERT etc.). These interactions of RNA-protein are found to be involved in telomerase assembly in a functional form (Dragon et al., 2000; Pogacic et al.,2000).

3.2. TELOMERASE REVERSE TRANSCRIPTASE (TERT)

TERT is the telomerase's core subunit and have RNA dependent DNA polymerase activity which synthesizes DNA by using its own RNA template. The location of gene encoding human TERT is found to be on chromosome 5 (5p15.33). hTERT gene stretches more than 37 kb, containing 16 exons and 15 introns coding 1132 amino acid residues (Wick et al.,1999). In humans (hTERT), protozoans, *Saccharomyces cerevisiae* (Est2), and *Schizosaccharomyces pombe* (Trt1), this subunit is found to be conserved (Lingner et al.,1997, Nakamura et al.,1997). TERT protein has 4 domains – RNA binding domain (TRBD), palm, finger and thumb (Gillis et al.,2008).

On the basis of structure and function, TERT protein can be classified into three main domains – the thumb, palm and finger subdomains containing reverse transcriptase domain, telomerase essential N-terminal domain and TERT RNA binding domain. These TERT subunits show conservation with reverse transcriptase or retroviruses. Tert expression level varies in normal and immortal cells. Low or undetectable expressions is often found in somatic cells (normal cells) while immortal cells show high

expression (M.A. Blasco, 2005). The over-expression of TERT has been found to increase lifespan of mice by over-expressing tumor suppressor genes such as p16, p19 and p53 (Zhang et al.,2010). Oncogenes, tumor suppressor genes (TSG) and surrounding chromatin regulates TERT transcription. According to Liu and colleagues, interactions of C-terminus of p53 and human telomerase associated protein 1 (hTEP1) causes inhibition of activity of telomerase (Li et al.,1999).

3.3 TELOMERASE RECRUITMENT

Telomerase recruitment in a timely manner to the chromosome end is the important step with for telomerase action. In *Saccharomyces cerevisiae* it has been found that telomerase recruitment is mediated by an interaction between ever short chromosome 1 (EST1) and Cdc13. EST1 is a constituent of telomerase complex while Cdc13 is a protein which binds to single-stranded overhang (Lundblad and Evans, 1999; Qian and Zakian, 2000). The Ku complex also mediates another pathway, by binding to the telomeric DNA and RNA of telomerase (Peterson et al., 2001; Stellwagen et al., 2003). Ku70-Ku80 complex in humans has been found in association with telomerase via interactions with both hTERT and hTERC (Chai et al., 2002; Ting et al., 2005). The role of Ku in recruitment mechanism of telomerase to telomere in mammals is still not clear. Ku70 – deficient mouse is found to show no defect in telomere maintenance (Celli et al., 2006). TERT and TPP1 interaction enhances the processivity of telomerase (Wang et al., 2007; Xin et al.,2007) and this interaction is required for the repression of the DNA damage response. Several studies have found the role of TPP1 in telomerase recruitment (Abreu et al., 2010) and the bridging of telomerase to telomere through heterogenous nuclear RNP protein A1 (LaBranche et al., 1998).

4. TELOMERE BINDING PROTEINS – TELOMERE MAINTENANCE AND CHROMOSOME STABILITY

Telomeric DNA interacts with a set of specialized proteins which comprises of different constituents, layouts and roles beyond species (de Lange, 2009). Telomere maintenance in mammalian cells depend on the interaction of six protein complexes at the telomere. These six protein complexes are termed as telosome or shelterin complexes (D.Liu et al.,2004,T.deLange et al.,2005). Components of shelterin complexes are: TRF1, TRF2, TIN2, RAP1, POT1, TPP1 (T.deLange et al.,2005). Shelterin complex plays a major role in chromosome stability by distinguishing chromosome ends to protect it from DNA damage and repair pathways (namely NHEJ, ATR, ATM, NHEJ, HDR and resection).



4.1. TRF1

TRF1 binds as homodimers to the duplex region of telomeric DNA and acts as negative regulator of telomere length (B. van Steensel et al.,1997). Dimerization occurs through TRF1 homology (TRFH) domain which also mediates the interactions with other telomeric proteins. TRF1 has a distinct protective function. It overcomes the major challenges of DNA replication machinery regarding the G-rich and highly repetitive nature of telomeric DNA. It protects the telomeric end from breakage when copying of telomeric DNA takes place by promoting the DNA replication machinery (Martínez et al., 2009; Sfeir et al.,2009). In mice, homozygous inactivation of TRF1 is embryonic lethal and cannot be rescued even in absence of telomerase, showing important role of TRF1 which doesn't act according to the length of telomere (J.Karlseder et al.,2003).

4.2. TRF2

TRF2 binds to double stranded telomeric DNA, playing a pivotal role in maintenance of telomere by negative regulation and protecting its end. TRF2 recruits various factors for telomere regulation. Homozygous deletion of TRF2 in mice, like TRF1, is embryonic lethal. Activation of kinase ATM takes place by TRF2 deletion (Celli and de Lange,2005), which leads to the assembly of DNA damage factors like 53BP1,H2AX at the telomere (Dimitrova and de Lange, 2006; Denchi and de Lange, 2007; Dimitrova and de Lan ge, 2009). Activation of p53 is done by ATM by phosphorylating it. After activation p53 acts as transcription factor for p21 gene and leads to synthesis of p21 protein which acts as cyclin inhibitor and induces cell cycle arrest. TRF2 absence also activates ligase 4 and Ku mediated NHEJ repair at telomeres, resulting in end to end fusions of chromosome (Celli and Lange,2005). The mechanism of the repression of NHEJ and ATM is not known and is currently under investigation. The repression may be due to covering of telomere terminus in the t-loop structure formed by TRF2. This is derived by the observation that in-vitro purified TRF2 binds at the junction of t-loop (Stansel et al.,2009), promoting the formation of structure resembling t-loop (Poulet et al.,2009). A t-loop structure prevents the detection of telomere end by DNA damage sensor of the ATM pathway. This structure also blocks NHEJ repair by preventing binding of Ku70-Ku80 complex to telomere terminus.

4.3. POT1

POT1 is a single stranded, G-rich DNA binding protein. It coats the telomeric overhang with its oligonucleotide / oligosaccharide binding (OB) folds. N-terminal OB fold binds to the six nucleotides

and second OB fold binds and protects 3' end of single stranded DNA (M. Lei et al.,2004). Mice have two paralogs of POT1 (POT1a and POT1b) with similar structure and distinct function (Hockemeyer et al.,2006). POT1 and POT1a in humans and mice respectively, repress the ATR mediated DNA damage response. The length of the single stranded overhang is regulated by POT1b (Hockemeyer et al.,2005; Hockemeyer et al., 2006; Wu et al.,2006). POT1 and POT1a blocks the ATR pathway by preventing the binding / excluding the replication protein A (RPA) to single stranded telomeric DNA. RPA is a single stranded binding protein and sensor in the ATR pathway. From recent studies it has been demonstrated that hnRNPA1, TERRA and POT1 act together to displace RPA from telomeric single stranded DNA after DNA replication, promoting telomere end protection (R.L. Flynn et al.,2011).

TERRA (telomeric repeat containing RNA) is a non-coding RNA and is found to be important in telomere maintenance and function (Redon et al., 2010; Flynn et al., 2011). Transcription of this non-coding RNA is done by RNA polymerase II and the initiation is from the sub-telomeric regions (Porro et al., 2010). TERRA is one of the components of the telomere nucleoprotein complex (Azzalin et al., 2007).

4.4 RAP1

Mammalian RAP1 interacts with TRF2 for telomere localization as they lack telomere binding capacity (Li et al.,2000). RAP1 inhibits homology directed repair (HDR) at telomeres. RAP1, POT1 and Ku are found to cooperate to block recombination, however the mechanism has not yet been elucidated.

4.5. TPP1

Large scale affinity purification is used for the purification of this protein. TPP1 is found to interact both with TIN2 and POT1 (Liu et al.,2004). TPP1 helps in the recruitment of POT1 and telomerase at telomere (Wang et al.,2007; Xin et al.,2007). TPP1 also shows interaction with ss-telomeric DNA binding protein OBFC1/Stn1, which controls the telomere length by negative regulation (Wu et al.,2012). Hence TPP1 protects telomere end via repression of ATR mediated DNA damage signalling and regulates telomere length by recruiting telomerase at telomere.

4.6. TIN2

TIN2 is the central component of shelterin complex as it directly interacts with TRF1, TRF2 and TPP1. It helps in telomere localization of all telomeric components (O'Connor et al., 2006). In mice TIN2 inactivation is embryonic lethal as it facilitates the TRF2-dependent inhibition of ATM mediated DNA repair, telomerase recruitment and control of telomere length (Takai et al., 2011).



4.7. Other Functions of telomere Proteins

Telomerase and telomere proteins have wide range of functions rather than telomere length regulation and telomere end stability. Some telomere proteins localize and interact in the cytoplasm, such as TIN2, TPP1, and POT1 (Chen et al., 2007). TRF2 play an important role in regulation of stem cells and neural tumor proliferation and differentiation (Zhang et al., 2008; Zhang et al., 2006). It is also involved in the homologous recombination (HR) repair of DSB at the non-telomeric regions (Mao et al., 2007; Bradshaw et al., 2005). TIN 2 possess mitochondrial localization signal. Recently it has been found that TIN2 has some role in metabolic control as RNAi mediated silencing of TIN2 enhances oxygen consumption and mitochondrial ATP synthesis (Chen et al., 2012). Telomerase has also non-telomeric function. Telomerase can regulate apoptotic responses due to oxidative stress by localizing to the mitochondria and sensitizing the mitochondrial DNA to hydrogen peroxide. Protein subunit of telomerase, TERT, has a N-terminal leader sequence containing mitochondrial localization signal that target TERT to mitochondria (Haendeler et al., 2003). Mitochondrial oxidative stress triggers the TERT nuclear export (Haendeler et al., 2004). Telomerase show RNA dependent RNA-polymerase activity in mitochondria, act as transcription factors in Wnt signalling pathway and are also involved in regulation of DNA repair and apoptosis.

5. TELOMERE RELATED HUMAN DISEASES

Somatic cells are prone to telomere shrinkage as they lack telomerase. Shortening of telomere may loosen the protective shelterin complex binding, forcing the cell to face two outcomes. Telomere eroded cells undergoes the process of cell senescence with checkpoints but telomere dysfunction in p53 lacking cells causes genomic instability and further lead to tumor progression. Any defect in telomere regulators contribute to human diseases which are of various origins and associated with ageing like heart disease, liver cirrhosis, ulcerative colitis and atherosclerosis (Wiemann et al., 2002; Samani et al., 2001). Short telomere length can directly contribute to premature ageing syndromes like Dyskeratosis congenital, Aplastic anaemia, Wrener syndrome, Bloom syndrome, ATM syndrome.

Telomere dysfunction also leads cancer formation in cells lacking cell cycle check points. Telomerase activity is absent in normal human cells and thus they face the problem of telomere shortening with each cell cycle and when they reach up to the critical length they undergo the process of replicative senescence. But cells lacking cell cycle check points continue to divide by evading

replicative senescence. They further face the growths arrest state i.e. crisis. In absence of telomerase and telomeric proteins many small chromosome ends fuses and ultimately lead to apoptosis. Cells escaping crisis show two important hallmarks i.e. telomere stability and re-activation of expression of telomerase. Thus, these cells grow continuously, resulting in carcinogenesis. Short telomeres are recognized as double strand breaks and induces the non-homologous end joining pathway based DNA damage repair which results in end-to-end chromosomal fusions. When these fused chromosomes undergo the mitotic cycles results in breakage of fused chromosomes and finally chromosomal aberrations. This accumulation of chromosomal aberrations leads to malignant transformation (Blasco et al., 1997). Approximately in 90% of the all malignant tumors have high expression of telomerase (Kim et al., 1994; Blasco and Hahn, 2003). In many types of cancer there is amplification of 5p15.33 loci which codes for telomerase subunit TERT (Hahn and Meyerson, 2001).

6. THERAPEUTIC APPROACHES

Diseases caused by human ageing and syndromes of premature ageing due to short telomere can be corrected by temporary telomerase reactivation. The germ-line introduction of telomerase leads to extension of telomere length in mouse models of inherited short telomere. This prevented the end-to-end fusion of chromosomes which solves the problems related to disease linked with chromosome fusion like bone marrow aplasia, infertility, hypogonadism and intestinal epithelium atrophy (Samper et al., 2001). Reintroduction of telomerase TERT subunit with NBS1 in cultured cells can correct the Nijmegen breakage syndrome (Ranganathan et al., 2001). Werner syndrome cells having short telomeres can be corrected by reintroduction of telomerase which extends the lifespan of the cells (Wyllie et al., 2000). But there is problem with reintroduction of telomerase in telomerase deficient cells that it may grow continuously and lead to tumor formation.

6.1. Therapeutical Approach Regarding Cancer

In 80-90% of cancers, there is elevation in expression level of telomerase. Telomerase inhibition thus can be an effective strategy to control tumor growth (Shay et al., 2002). Therapeutic strategies that focus on telomerase targeting in cancer cells have been designed in the past recent years. Targeted inhibition of telomerase in tumor triggers the shortening of chromosome which lead to loss of cell viability in tumor.

Use of small synthetic molecules to inhibit the telomerase enzymatic activity is becoming popular.



2-[[E]-3-naphthalene-2-yl-but-2-enoylamino]-benzoic acid or BIBR1532 is a non-competitive inhibitor of both TERT and TERC (Pascolo et al., 2002). Treatment of cells with this drug, in-vitro, gave positive result regarding telomere length reduction and inhibition of cell proliferation. But it is cytotoxic at higher dose (Damm et al., 2001). G-quadruplex stabilization inhibits telomerase activity by preventing TERC telomerase subunit from recognizing 3' overhang hydroxyl group on single stranded telomeric DNA. Small synthetic molecules such as G-quadruplex ligands, have been used for the stabilization of quadruplex structure of telomere (Neidle, 2010). Telomestatin macrocyclic compound from *Streptomyces anulatus* used as G-quadruplex ligands and potentially inhibits telomerase (Kim et al., 2001). To overcome the problems regarding small molecule inhibition immunotherapy in which tumor associated antigen (TAAs), TERT-based vaccination etc. and gene therapy involving TERT or TERC expression inhibition by siRNA, utilization of promoters of TERT or TERC for exogenous vectors expression etc. are used.

6.2. Challenges

Telomerase expression is observed in blood cells in bone marrow, skin basal layer cells, and epithelial cells of the mucosa. Thus different therapeutic approach targeting telomerase can affect the normal cells. Generally, tumor cells have shorter telomeres than the surrounding normal tissues as tumor cells proliferation rates are high which causes decrease in their telomere length. Some more challenges regarding therapeutic potentials are issue of short telomere, ideal target, pharmaco-kinetic, and safety issues.

The combination of already established therapies of cancer and treatments based on telomerase may be effective strategy to overcome these challenges.

7. CONCLUSION AND FUTURE

PERSPECTIVES

From the above gathered information it is clear that telomere shortening with increasing age or mutations are the main cause of human diseases.

Telomere a special heterochromatin caps the end of chromosome and provides stability. Telomere length is maintained by telomerase, different telomere interacting proteins and epigenetic regulation. They key step in telomere length maintenance is recruitment of telomerase on telomere which is controlled by many factors. Any defect in the telomere maintenance machinery leads to human age related diseases, premature ageing syndromes and cancers. Telomerase extra telomeric functions have also been confirmed which promotes tumorigenesis. There are still more to explore in this

field. By having depth study at molecular level of epigenetic regulation, telomerase and telomere binding protein and their interaction with other proteins or molecules can explore many things about them and their regulations in cell which may help in correcting telomeric defects. In case of cancer due to lack of depth therapeutic strategies fails in in vivo experiments. Deep knowledge about telomere biology and specific targeting may solve the challenges regarding therapeutic approaches in telomere related diseases.

REFERENCES

1. Abreu E, Aritonovska E, Reichenbach P, Cristofar G, Culp B, Terns RM, Lingner J and Terns MP (2010): *TIN2-tethered TPP1 recruits human telomerase to telomeres in vivo*. *Mol Cell Biol.* 30, 2971- 2982.
2. Azzalin CM, Reichenbach P, Khoriant L, Giulotto E and Lingner J (2007): *Telomeric repeat containing RNA and RNA surveillance factors at mammalian chromosome ends*. *Science.* 318, 798-801.
3. B Li, S Oestreich, T de Lange (2000): *Identification of human Rap1: implications for telomere evolution*. *Cell.* 101, 471-483.
4. B.vanSteensel, T de Lange (1997): *Control of telomere length by the human telomeric protein TRF1*. *Nature.* 385,740-743.
5. Blackburn EH & Szostak JW (1984): *The molecular structure of centromeres and telomeres*. *Annu Rev Biochem.* 53, 163-194.
6. Blasco MA and Hahn WC (2003): *Evolving views of telomerase and cancer*. *Trends Cell Biol.* 13, 289-294.
7. Blasco MA, Funk W, Villeponteau B and Greider CW (1995): *Functional characterization and developmental regulation of mouse telomerase RNA*. *Science.* 269, 1267-1270.
8. Blasco MA, Lee HW, Hande MP, Samper E, Lansdorp PM, DePinho RA & Greider CW (1997): *Telomere shortening and tumor formation by mouse cells lacking telomerase RNA*. *Cell.* 91, 25-34.
9. Celli G B, Denchi E L and de Lange T (2006): *Ku70 stimulates fusion of dysfunctional telomeres yet protects chromosome ends from homologous recombination*. *Nat Cell Biol.* 8, 855-890.
10. Celli GB and de Lange T (2005): *DNA processing is not required for ATM-mediated telomere damage response after TRF2 deletion*. *Nat Cell Biol.* 7, 712-718.
11. Chai W, Ford LP, Lenertz L, Wright W E and Shay JW (2002): *Human Ku70/80 associates physically with telomerase through interaction with hTERT*. *J Biol Chem.* 277, 47242-47247.
12. Chang JT, Chen YL, Yang HT, Chen CY and Cheng AJ (2002): *Differential regulation of telomerase activity by six telomerase subunits*. *Eur. J. Biochem.* 269, 3442-3450.



13. Chen JL, Blasco MA and Greider CW (2000): Secondary structure of vertebrate telomerase RNA. *Cell*. 100, 503-514.
14. D Hockemeyer, JP Daniels, H Takai, T de Lange (2006): Recent expansion of the telomeric complex in rodents: two distinct POT1 proteins protect mouse telomeres. *Cell*. 126, 63-77.
15. D Liu, A Safari, MS O'Connor, DW Chan, A Laegeler, J Qin, Z Songyang (2004): POT1 interacts with POT1 and regulates its localization to telomeres. *Nat Cell Biol*. 6, 673-680.
16. D Liu, MS O'Connor J. Qin Z Songyang (2004): Telosome, a mammalian telomere-associated complex formed by multiple telomeric proteins. *JBiolChem*. 279, 51338-51342.
17. Damm K et al. (2001): A highly selective telomerase inhibitor limiting human cancer cell proliferation. *EMBO J*. 20, 6958-6968.
18. de Lange T (2009): How telomeres solve the endprotection problem. *Science*. 326, 948-952.
19. Denchi E L and de Lange T (2007): Protection of telomeres through independent control of ATM and ATR by TRF2 and POT1. *Nature*. 448, 1068-1071.
20. Dimitrova N and de Lange T (2006): MDC1 accelerates nonhomologous end-joining of dysfunctional telomeres. *Genes Dev*. 20, 3238-3243.
21. Dimitrova N and de Lange T (2009): Cell cycle-dependent role of MRN at dysfunctional telomeres: ATM signaling-dependent induction of nonhomologous end joining (NHEJ) in G1 and resection-mediated inhibition of NHEJ in G2. *Mol Cell Biol*. 29, 5552-5563.
22. Dragon F, Pogacic V and Filipowicz W (2000): In vitro assembly of human H/ACA small nucleolar ribonucleoproteins reveals unique features of U17 and telomerase RNA. *Mol Cell Biol*. 20, 3037-3048.
23. Evans SK and Lundblad V (1999) : Est1 and Cdc13 as comediators of telomerase access. *Science*. 286, 117- 120.
24. F Wang, Y Yin, X Ye, K Liu, H Zhu, L Wang, M Chiourea, M Okuka, G Ji, J Dan, B Zuo, M Li, Q Zhang, N Liu, L Chen, X Pan, S Gagos, DL Keefe, L Liu (2012): Molecular insights into the heterogeneity of telomere reprogramming in induced pluripotent stem cells. *Cell Res*. 22, 757-768.
25. Feng J, Funk WD, Wang SS, Weinrich SL, Avilion AA, Chiu CP, Adams RR, Chang E, Allsopp RC, Yu J, Le S, West MD, Harley CB, Andrews WH, Greider CW and Villeponteau B (1995): The RNA component of human telomerase. *Science*. 269, 1236-1241.
26. Gillis AJ, Schuller AP and Skordalakes E (2008): Structure of the *Tribolium castaneum* telomerase catalytic subunit TERT. *Nature*. 455, 633-637.
27. Greider, CW and Blackburn EH (1989): A telomeric sequence in the RNA of *Tetrahymena* telomerase required for telomere repeat synthesis. *Nature*. 337, 331-337.
28. H Li, Y Cao, MC Berndt, JW Funder, JP Liu (1999): Molecular interactions between telomerase and the tumor suppressor protein p53 in vitro. *Oncogene*. 18, 6785-6794.
29. H Xin, DLiu, M Wan, A Safari, H Kim, W Sun, MS O'Connor, Z Songyang (2007): TPP1 is a homologue of ciliate TEBP-beta and interacts with POT1 to recruit telomerase. *Nature*. 445, 559-562.
30. Haendeler J, Hoffmann J, Rahman S, Zeiher AM and Dimmeler S (2003): Regulation of telomerase activity and anti-apoptotic function by protein-protein interaction and phosphorylation. *FEBS Lett*. 536, 180-186.
31. Haendeler J, Hoffmann J, Diehl JF, Vasa M, Spyridopoulos I, Zeiher AM and Dimmeler S (2004): Antioxidants inhibit nuclear export of telomerase reverse transcriptase and delay replicative senescence of endothelial cells. *Circ Res*. 94, 768-775.
32. Hahn, WC and Meyerson M (2001): Telomerase activation, cellular immortalization and cancer. *Ann Med*. 33, 123-129.
33. Hockemeyer D, Sfeir A J, Shay JW, Wright WE and de Lange, T (2005): POT1 protects telomeres from a transient DNA damage response and determines how human chromosomes end. *EMBO J*. 24, 2667-2678.
34. J Karlseder, L Kachatrian, H Takai, K Mercer, S Hingorani, T Jacks, T de Lange (2003): Targeted deletion reveals an essential function for the telomere length regulator Trf1. *Mol Cell Biol*. 23, 6533-6541.
35. Kim MY et al. (2002): Telomestatin, a potent telomerase inhibitor that interacts quite specifically with the human telomeric intramolecular G-quadruplex. *J Am Chem Soc*. 124, 2098-2099.
36. Kim NW et al. (1994): Specific association of human telomerase activity with immortal cells and cancer. *Science*. 266, 2011-2015.
37. KK Takai, T Kibe, JR Donigian, D Frescas, T de Lange (2011): Telomere protection by TPP1/POT1 requires tethering to TIN2. *Mol Cell*. 44, 647-659.
38. Kornberg A (1974): DNA Synthesis. W.H. Freeman, San Francisco.
39. L Wu, AS Multani, H He W Cosme-Blanco, Y Deng, JM Deng, O Bachilo, S Pathak, H Tahara, SM Bailey, RR Behringer, S Chang (2006): Pot1 deficiency initiates DNA damage checkpoint activation and aberrant homologous recombination at telomeres. *Cell*. 126, 49-62.
40. LaBranche H, Dupuis S, Ben-David, Y, Bani MR, Wellinger RJ and Chabot B (1998): Telomere elongation by hnRNP A1 and a derivative that interacts with telomeric repeats and telomerase. *Nat Genet*. 19, 199-202.
41. Lingner J, Hughes TR, Shevchenko A, Mann M, Lundblad V and Cech TR (1997): Reverse transcriptase motifs in the catalytic subunit of telomerase. *Science*. 276, 561-567.



42. LY Chen, D Liu, Z Songyang, *Telomere maintenance through spatial control of telomeric proteins. Mol Cell Biol.* 27, 5898–5909.
43. LY Chen, Y Zhang, Q Zhang, H Li, Z Luo, H Fang, SH Kim, L Qin, P Yotnda, J Xu, BP Tu, Y Bai, Z Songyang (2012): *Mitochondrial localization of telomeric protein TIN2 links telomere regulation to metabolic control. Mol Cell (Epub ahead of print).*
44. M Lei, ER Podell, TR Cech (2004): *Structure of human POT1 bound to telomeric single-stranded DNA provides a model for chromosome end protection. Nat Struct Mol Biol.* 11, 1223–1229.
45. MA Blasco (2005): *Telomeres and human disease: ageing, cancer and beyond. Nat Rev Genet.* 6, 611–622.
46. Makarov, V L, Hirose, Y and Langmore, J P (1997): *Long G tails at both ends of human chromosomes suggest a C strand degradation mechanism for telomere shortening. Cell.* 88, 657-666.
47. Martinez P, Thanasoula M, Munoz P, Liao C, Tejera A, McNees C, Flores J M, Fernandez-Capetillo, O Tarsounas M and Blasco M A (2009): *Increased telomere fragility and fusions resulting from TRF1 deficiency lead to degenerative pathologies and increased cancer in mice. Genes Dev.* 23, 2060-2075.
48. Mason JM, Frydrychova RC, and Biessmann H (2008): *Drosophila telomeres: an exception providing new insights. Bioessays.* 30, 25–37.
49. Matera AG, Terns RM and Terns MP (2007): *Non-coding RNA: lessons from the small nuclear and small nucleolar RNA. Nat Rev Mol Cell Biol.* 8, 209-220.
50. McElligott, R and Wellinger, R J (1997): *The terminal DNA structure of mammalian chromosomes. EMBO J.* 16, 3705-3714.
51. Mitchell JR and Collins K (2000): *Human telomerase activation requires two independent interactions between telomerase RNA and telomerase reverse transcriptase. Mol Cell.* 6, 361-371.
52. ML Zhang, XJ Tong, XH Fu, BO Zhou, J Wang, XH Liao, QJ Li, N Shen, J Ding, JQ Zhou (2010): *Yeast telomerase subunit Est1p has guanine quadruplex-promoting activity that is required for telomere elongation. Nat Struct Mol Biol.* 17, 202–209.
53. MS O'Connor, A Safari, H Xin, D Liu, Z Songyang (2006): *A critical role for TPP1 and TIN2 interaction in high-order telomeric complex assembly. Proc Natl Acad Sci USA.* 103, 11874–11879.
54. Muller HJ (1938): *The remaking of chromosomes. Collecting Net.* 13, 181–198.
55. Nakamura TM, Morin GB, Chapman KB, Weinrich SL, Andrews WH, Lingner J, Harley CB and Cech TR (1997): *Telomerase catalytic subunit homologs from fission yeast and human. Science.* 277, 955-959.
56. Oganessian L and Karlseder J (2011): *Mammalian 59 C-rich telomeric overhangs are a mark of recombination-dependent telomere maintenance. Mol Cell.* 42, 224-236.
57. P Wu, H Takai, T de Lange (2012) : *Telomeric30 overhangs derive from resection by Exo1 and Apollo and fill-in by POT1b-associated CST. Cell.* 150, 39–52.
58. P Zhang, K Furukawa, PL Opreško, X Xu, VA Bohr, MP Mattson (2006): *TRF2 dysfunction elicits DNA damage responses associated with senescence in proliferating neural cells and differentiation of neurons. J Neurochem.* 97, 567–581.
59. P Zhang, MJ Pazin, CM Schwartz, KG Becker, RP Wersto, CM Dilley, MP Mattson (2008): *Nontelomeric TRF2–REST interaction modulates neuronal gene silencing and fate of tumor and stem cells. Curr Biol.* 18, 1489–1494.
60. Pascolo E et al. (2002): *Mechanism of human telomerase inhibition by BIBR1532, a synthetic, non-nucleosidic drug candidate. J Biol Chem.* 277, 15566–15572.
61. Peterson SE, Stellwagen AE, Diede SJ, Singer M S, Haimberger ZW, Johnson CO, Tzoneva M and Gottschling D E (2001): *The function of a stemloop in telomerase RNA is linked to the DNA repair protein Ku. Nat Genet.* 27, 64-67.
62. Pogacic V, Dragon F and Filipowicz W (2000): *Human H/ACA small nucleolar ribonucleoproteins and telomerase share evolutionarily conserved proteins NHP2 and NOP10. Mol Cell Biol.* 20, 9028-9040.
63. Porro A, Feuerhahn S, Reichenbach P and Lingner J (2010): *Molecular dissection of telomeric repeat-containing RNA biogenesis unveils the presence of distinct and multiple regulatory pathways. Mol Cell Biol.* 30, 4808-4817.
64. Poulet A, Buisson R, Faivre-Moskalenko C, Koelblen M, Amiard S, Montel F, Cuesta-Lopez S, Bornet O, Guerlesquin F, Godet T et al. (2009): *TRF2 promotes, remodels and protects telomeric Holliday junctions. EMBO J.* 28, 641-651.
65. PS Bradshaw, DJ Stavropoulos, MS Meyn (2005): *Human telomeric protein TRF2 associates with genomic double-strand breaks as an early response to DNA damage. Nat Genet.* 37, 193–197.
66. Qi H, and Zakian V A (2000): *The Saccharomyces telomere-binding protein Cdc13p interacts with both the catalytic subunit of DNA polymerase alpha and the telomerase-associated est1 protein. Genes Dev.* 14, 1777- 1788.
67. Raices M, Verdun R E, Compton S A, Haggblom C I, Griffith J D, Dillin A and Karlseder J (2008): *C. elegans telomeres contain G-strand and C-strand overhangs that are bound by distinct proteins. Cell.* 132, 745-757.
68. Ranganathan V et al. (2001): *Rescue of a telomere length defect of Nijmegen breakage*



- syndrome cells requires NBS and telomerase catalytic subunit. Curr Biol. 11, 962–966.*
69. Redon S, Reichenbach P and Lingner J (2010): *The non-coding RNA TERRA is a natural ligand and direct inhibitor of human telomerase. Nucleic Acids Res. 38, 5797-5806.*
70. RL Flynn, RC Centore, RJ O'Sullivan, R Rai, A Tse, Z Songyang, S Chang, J Karlseder, L Zou, TERRA and hnRNPA1 orchestrate an RPA-to-POT1 switch on telomeric single-stranded DNA. *Nature. 471, 532–536.*
71. Samani N J, Boulby R, Butler R, Thompson JR & Goodall AH (2001): *Telomere shortening in atherosclerosis. Lancet. 358, 472–473.*
72. Samper E, Flores JM & Blasco MA (2001): *Restoration of telomerase activity rescues chromosomal instability and premature aging in Terc^{-/-} mice with short telomeres. EMBO Rep. 2, 1–8.*
73. Sfeir A, Kosiyatrakul ST, Hockemeyer D, MacRae S L, Karlseder J, Schildkraut C L and de Lange T (2009): *Mammalian telomeres resemble fragile sites and require TRF1 for efficient replication. Cell. 138, 90-103.*
74. Shay JW & Wright WE (2002): *Telomerase: a target for cancer therapeutics. Cancer Cell. 2, 257–265.*
75. Stansel RM, de Lange T and Griffith JD (2001): *T-loop assembly in vitro involves binding of TRF2 near the 39 telomeric overhang. EMBO J. 20, 5532-5540.*
76. Stellwagen AE, Haimberger ZW, Veatch JR and Gottschling DE (2003): *Ku interacts with telomerase RNA to promote telomere addition at native and broken chromosome ends. Genes Dev. 17, 2384-2395.*
77. TdeLange (2005): *Shelterin: the protein complex that shapes and safe guards human telomeres. GenesDev. 19, 2100–2110.*
78. Ting NS, Yu Y, Pohorelic B, Lees-Miller, SP and Beattie T L (2005): *Human Ku70/80 interacts directly with hTR, the RNA component of human telomerase. Nucleic Acids Res. 33, 2090-2098.*
79. Wang F, Podell E R, Zaug A J, Yang Y, Baciú P, Cech T R and Lei M (2007): *The POT1-TPP1 telomere complex is a telomerase processivity factor. Nature. 445, 506-510.*
80. Watson JD & Crick FH (1953): *Molecular structure of nucleic acids; a structure for deoxyribose nucleic acid. Nature. 171, 737–738.*
81. Wick M, Zubov D and Hagen G (1999): *Genomic organization and promoter characterization of the gene encoding the human telomerase reverse transcriptase (hTERT). Gene. 232, 97-106.*
82. Wiemann S U et al. (2002): *Hepatocyte telomere shortening and senescence are general markers of human liver cirrhosis. FASEB J. 16, 935–942.*
83. Wyllie FS et al. (2000): *Telomerase prevents the accelerated cell ageing of Werner syndrome fibroblasts. Nature Genet. 24, 16–17.*
84. Xin H, Liu D, Wan M, Safari A, Kim H, Sun W, O'Connor M S and Songyang Z (2007): *TPP1 is a homologue of ciliate TEBP-beta and interacts with POT1 to recruit telomerase. Nature. 445, 559-562.*
85. Z Mao, A Seluanov, Y Jiang, V Gorbunova (2007): *TRF2 is required for repair of nontelomeric DNA double-strand breaks by homo logous recombination. Proc Natl Acad Sci USA. 104, 13068–13073.*



AWARENESS AND PERCEPTIONS TOWARDS CROP INSURANCE SCHEME IN SPECIAL REFERENCE TO COIMBATORE DISTRICT

Dr. M. Kalimuthu

*Assistant Professor, Department of Commerce with Professional Accounting,
Dr. N.G.P. Arts and Science College, Coimbatore*

Mr. R. Sounder

*Student, Department of Commerce with Professional Accounting, Dr. N.G.P. Arts and Science College,
Coimbatore*

ABSTRACT

Agriculture is the back bone of the Indian economy. Government has launched several insurance schemes like National Agricultural Scheme and Weather Index Based crop insurance schemes for shielding the farmers against risks in agriculture. Due to the danger of loss in agriculture the farmers are making suicide attempts, selling their properties or the properties are seized by the Bank and financial institutions for the loan availed by the farmers. This is due to lack of awareness about the risk management among the farmers. The research was conducted among the 120 farmers of Coimbatore District to assess the farmer's perception about the various facts of crop insurance schemes.

KEYWORDS : *Agriculture, Crop insurance, National Agricultural Scheme, Farmers Awareness, Risk management.*

INTRODUCTION

Agriculture may be a risky prospect, wherever it is subject to vagaries of nature like flood, drought and cyclone. Agriculture contributes 24 per cent to the GDP and its disturbance has a multiplier effect on the economy of a country like India. Since, economic process and agricultural growth are inextricably linked to each other, managing risks in agriculture may be a big challenge to the policy makers and therefore the researchers. The risk aversion induces under Crop insurance are recognized to be a basic instrument for maintaining stability in farmers income, through promoting technology, encouraging investment, and increasing credit flow with the agricultural sector. The basic principle underlying crop insurance is that the loss incurred by a couple of people is shared among others in an area, engaged in a similar activity. Also, losses incurred in bad years was compensated from the resources accumulated in good years.

STATEMENT OF THE PROBLEM

Crop insurance, thus, promotes flow of institutional credit to the agriculture sector which successively induces farmers to adopt new technology. The agricultural sector is still in development and is also growing significantly owing to promotional policies initiated by the government in these countries. The rural sector will offer a wide scope for the insurance companies particularly to the local companies which have better knowledge of realities in rural marketing. In this context, this study is an attempt to find out answers to the following questions.

1. What is the awareness level of the farmers about crop insurance schemes?
2. What are the problems faced by Crop Insurance Scheme?



SCOPE OF THE STUDY

In the present study, may helpful to small and marginal farmers to save their interest in crop against natural calamities and getting benefits under this scheme. It will also assist the insurers, bankers and policy makers for policy prescription and policy intervention. Crop insurance is taken into account be an efficient risk management tool for maintaining stability in farm income, through promoting technology, encouraging investment, and increasing credit flow in the agricultural sector. It contributes to self-reliance and self-respect among farmers, since in cases of crop loss they can claim their compensation.

OBJECTIVES OF THE STUDY

- To know the awareness of Crop Insurance Scheme in Coimbatore.
- To identify the problems that are faced by cultivator while getting Crop Insurance scheme.
- To provide suggestions to improve awareness among farmers for crop insurance scheme.
- To analyze the perception of the beneficiaries and non-beneficiaries regarding to the existing crop insurance schemes.

RESEARCH METHODOLOGY

Research methodology is the systematic way to solve research problem. It is a science of studying how the research is to be carried out. Its aim is to give work plan of the research. The study is based on a survey collected in Coimbatore district with the help of primary and secondary data.

DATA USED: Primary data and Secondary data are used.

AREA OF THE STUDY: The study was undertaken in Coimbatore district.

SAMPLE SIZE: The study was conducted with a sample size of 120 respondents.

ANALYTICAL TOOLS USED: Simple percentage, Likert scale analysis, Ranking Analysis

REVIEW OF LITERATURE

Bindiya Kunal Soni & Jigna Trivedi (2013) “Crop Insurance: An Empirical Study on

Awareness and Perceptions” Universally agriculture is perceived to be synonymous with risk and uncertainty. Crop insurance is one of the alternative to manage risk in yield loss by the farmers. It helps in stabilization of the farmer’s production and income of the farming community. As such it is a risk management alternative where production risk is transferred to another party at a cost premium.

Saraswathi kumbalep, m. Devaraju (2018) “awareness and perceptions of farmers about crop insurance” protecting the interest of farmers is very important in any country basically to have sustainable economy and food security. India is a developing country around 60–70 percent of Indian population is depending upon Agriculture sector and currently it contributes 16–17% of the GDP.

HISTORY & PROFILE OF THE STUDY

The Central Government has formulated the Farm Income Insurance Scheme during 2003-04. The two critical components of a farmer's income are the yield and price. FIIS targeted these two components through a single insurance policy so that the insured farmer can get a guaranteed income. The scheme provided income protection to the farmers by insuring the production and market risks. The insured farmers were ensured minimum guaranteed income that is, average yield multiplied by the minimum support price in a year. If the actual income was less than the guaranteed income, the insured would be compensated to the extent of the shortfall by the insurance. Initially, the scheme would cover only the wheat and rice and would be compulsory for farmers availing crop insurance. Would be withdrawn for the crops covered by FIIS, but would continue to be applicable for the other crops. The FIIS was withdrawn in 2004. The recent attempt by the government to re-introduce the Farm Income Insurance Scheme can reform agricultural insurance and prevent the farm-level distress.

**ANALYSIS****TABLE SHOWING DISTRIBUTION OF RANKING PERFORMANCE TOWARDS CROP INSURANCE SCHEME**

S. No	Particulars	1	2	3	4	5	TOTAL	RANK
1	Providing crop insurance scheme	25(5)	20(4)	27(3)	30(2)	18(1)	364	2
2	Providing relief fund at disaster time	50(5)	18(4)	16(3)	14(2)	22(1)	420	1
3	Service by the government	10(5)	25(4)	32(3)	29(2)	24(1)	328	4
4	Premium paid	16(5)	22(4)	25(3)	27(2)	30(1)	327	5
5	Renewal notice	19(5)	35(4)	20(3)	20(2)	26(1)	331	3

*(Source: Primary Data)***INTERPRPETATION**

From the table, it is understood that providing relief fund at disaster time is ranked 1, providing crop insurance scheme is ranked 2, Renewal notice is ranked

3, Service by the government is ranked 4, and Premium paid is ranked 5.

➤ Providing relief fund at disaster time have been ranked 1st by the respondents.

TABLE SHOWING DISTRIBUTION OF RANKING PERFORMANCE TOWARDS CLAIMING CROP INSURANCE

S. No	Particulars	1	2	3	4	5	TOTAL	RANK
1	Receiving of insurance amount	25(5)	40(4)	25(3)	15(2)	15(1)	405	1
2	Recovery of full loss	35(5)	20(4)	7(3)	25(2)	33(1)	329	4
3	Process for claiming insurance amount	12(5)	25(4)	28(3)	33(2)	12(1)	322	5
4	Coverage of risk	18(5)	15(4)	41(3)	27(2)	19(1)	346	3
5	Claiming process	30(5)	20(4)	19(3)	20(2)	31(1)	358	2

*(Source: Primary Data)***INTERPRPETATION**

From the table, it is understood that Receiving of insurance amount is ranked 1, Receiving of insurance amount is ranked 2, Coverage of risk is ranked 3, and Recovery of full loss is ranked 4, Process for claiming insurance amount is ranked 5.

➤ Receiving of insurance amount have been ranked 1st by the respondents.

FINDINGS**1. SIMPLE PERCENTAGE METHOD**

- 60.8% of the respondents are Male.
- 60.8% of the respondents are in the group of 41 to 60 years.
- 79.2% respondents are married.
- 29.2% of the respondents are in the family of 2 and 3 members.
- 48.3% of respondents are at up to school level.
- 46.7% of the respondents are live in rural areas.



- 43.3% of the respondents having yearly income of Rs.2 to 3 lakhs.
- 50.8% of the respondents owns less than 3 acres of land.
- 41.7% of the respondents have involved in farming 5 to 10 years.
- 100% of respondents are aware with crop insurance.
- 100% of the respondents are not insured their crops.
- 34.1% of respondents are aware by the government departments.
- 53.3% of respondents are avile with the medium term loan.
- 31.7% of the respondents are affected by the non aviability of workers.
- 32.5% of the respondent's avile with bank loan for the risk management.
- 33.3% of the respondents are aware with various crop insurance scheme.
- 33.3% of the respondents faced the problems like no proper valuation of loss and it is a long process.

2. LIKERT SCALE ANALYSIS

TABLE SHOWS THE LEVEL OF SATISFACTION OF THE RESPONDENTS IN CROP NSURANCE SCHEME

S. NO.	FACTORS	NO. OF RESPONDENTS	LIKERT SACLE VALUES(x)	TOTAL
1	Highly satisfied	8	5	40
2	satisfied	34	4	136
3	Neutral	48	3	144
4	Dissatisfied	22	2	44
5	Highly Dissatisfied	8	1	8
	TOTAL	120		372

(Source: Primary data)

INTERPRETATION

- Likert scale value 3.1 which is equal to the mid value 3, so the respondents are neutral in the crop insurance scheme.
- The respondents agreeing with the crop insurance scheme it helps them while unexpected loss has made.
- The respondents are natural with the factors.

3. RANKING ANALYSIS

- Providing relief fund at disaster time have been ranked 1st by the respondents.
- There is no significant difference between age and earning capacity of farmers.
- There is no significant difference between education level and economic condition of farmers
- Limited numbers of farmers are aware with the various crop insurance scheme.
- the major risk in farming are the drought and non-availability of workers
- Crop insured farmers are dissatisfied from the existing insurance schemes.

- in order to bear the risk of loss the farmers are borrowing loans banks

SUGGESTIONS

- Proper awareness of crop Insurance schemes and procedure to buy policy should be created.
- All crops need to be covered to make it a strong risk mitigating tool.
- Indemnity payment should meet the loss incurred and it should not be negligible amount.
- Procedure to purchase Crop Insurance should be made easy and at farmers door step or nearest place
- Awareness for the crop insurance can be created by service providers through SMS, hoardings, television and radios

CONCLUSION

Agriculture is affected by the natural calamities like drought, flood, etc., which forms the major risk for the farmers. Theoretically the crop insurance stabilizes the farmer's income during the loss period. But in real practice it doesn't act as an



instrument during the period of loss. In the mindset of the farmers the crop insurance is best suited for large scale farmers because the premium is not afford to the small & medium farmers further the extent of coverage is very low. The major role in creating the awareness among farmers is played the Bank officials but they didn't take active participation in explaining the benefits of crop insurance. Hence the benefits of the crop insurance should reach all types of farmers and change the perception of the farmers about the cultivation and its risk aversion.

REFERENCE

1. Bindiya Kunal Soni & Jigna Trivedi (2013) "**Crop Insurance: An Empirical Study on Awareness and Perceptions**" *GIAN JYOTI E-JOURNAL*, Volume 3, Issue 2 (Apr-Jun 2013) E-ISSN 2250-348X PP.NO:81 TO 93.
2. SARASWATHI KUMBALEP, M. DEVARAJU (2018) "**awareness and perceptions of farmers about crop insurance**" *International Journal of Advances in Science Engineering and Technology*, ISSN(p): 2321 –8991, ISSN(e): 2321 –9009 Vol-6, Iss-1, Spl. Issue-1 Feb.-2018 PP.NO:90 TO 94.
3. Dr.S.M.UVANESWARAN , T.MOHANAPRIYA (March, 2014)¹ "**farmers perception and awareness about crop insurance in tamilnadu – a descriptive analysis**" *INTERCONTINENTAL JOURNAL OF MARKETING RESEARCH REVIEW* Volume 2, Issue 3 (March, 2014) ISSN: 2321-0346- Online ISSN:2347-1670-Print PP. NO:15 TO 22
4. ANJU DUHAN(2017) "**farmer's perceptions towards crop insurance**" *IMPACT: International Journal of Research in Applied, Natural and Social Sciences (IMPACT: IJRANSS)* ISSN (P): 2347-4580; ISSN (E): 2321-8851 Vol. 5, Issue 8, Aug 2017, 1-6 PP. NO:1 TO 6.
5. D. Suresh Kumara, B.C. Barahb, C.R. Ranganathana, R. Venkatrama, S. Gurunathana and S. Thirumoorthya (2011)¹ "**An Analysis of Farmers' Perception and Awareness towards Crop Insurance as a Tool for Risk Management in Tamil Nadu**" *National Centre for Agricultural Economics and Policy Research, New Delhi-110 012* Vol. 24 January-June 2011 pp 37-46.



A STUDY ON FINANCIAL PERFORMANCE ANALYSIS OF HINDUSTAN PETROLEUM CORPORATION LIMITED

Mr. Dr. M. Kalimuthu.

*Assistant Professor, Department of Commerce with Professional Accounting,
Dr. N.G.P. Arts and Science College, Coimbatore*

Miss. Preeti Jaiswal. A

*Student, Department of Commerce with Professional Accounting, Dr. N.G.P. Arts and Science College,
Coimbatore*

ABSTRACT

Finance is need for day to day operation and it is considered as a life blood for business. Profitability is the profit earning capacity which is a crucial factor contributing for the survival of the firms. Profitability analysis is the process of identifying the financial strengths and weakness of the Hindustan Petroleum Corporation Limited (HPCL) from the available accounting data and financial statements. This study aims at analysing the overall financial profitability of the HPCL by using various financial tools. Further, to measure the effectiveness of the above mentioned company, ratio analysis techniques have been used as tool to provide suitable suggestions and recommendations for this study.

KEY WORDS : *Financial Performance, Ratio Analysis, Liquidity Ratio, Profitability Ratio.*

INTRODUCTION

Financial performance in broader sense refers to the degree to which financial objectives being or has been accomplished and is an important aspect of financial risk management. It is the process of measuring the results of a firm's policies and operations in monetary terms. It is used to measure firm's overall financial health over a given period of time and can also be used to compare similar firms across the same industry or to compare industries or sectors in aggregation.

Financial performance includes analysis and interpretation of financial statements in such a way that it undertakes full diagnosis of the profitability and financial soundness of the business.

The financial analyst program provides vital methodologies of financial analysis.

STATEMENT OF THE PROBLEM

Finance is the scarcest resource in India and hence it needs to be utilized optionally. The sound performance of a firm depends on the well-planning of capital structure, investment and distribution. Any firm that fails to apply the sound principles of capital structure like cost, control and the firm that fails to adopt the scientific tool of investment and distribution in managing funds will not survive in the long run. Further, the firm should apply the wealth maximization as criteria in taking financial decisions like financing, investment and distribution. Since finance in the life blood and nervous system of an enterprise, the importance of the timely appraisal of the performance of the firm cannot be ignored.



OBJECTIVES OF THE STUDY

- To analyze the Liquidity position of the Hindustan Petroleum Corporation Limited.
- To evaluate the profitability of the company.
- To analyse the schedule of changes in Working capital for the period of five years. • To analyse the overall financial performance of HPCL

SCOPE OF THE STUDY

The study is based on the financial position of the firm by using ratio analysis and comparative statements. Financial statements help the management to analyze the profit, solvency, liquidity and efficiency etc. This analysis will give exact picture of the company. This study will also help the management to take managerial decisions. This study helps the management to understand the new possibilities.

RESEARCH METHODOLOGY

SOURCES OF DATA

Secondary data are used in this study, which were collected from the various data base, journal and magazines. Variables pertaining to behavior of liquidity, leverage and profitability were collected from the balance sheet and profit and loss account of the selected Hindustan Petroleum Corporation Limited for a period of 5 years.

PERIOD OF THE STUDY

The study covers the period of five years ranges from 2014-15 to 2018-19.

TOOLS AND TECHNIQUES

The tool used for calculation of financial performance analysis is following statistical tools were applied to analyze the statistical data collected.

1. Ratio analysis
 - Profitability Ratios
 - Liquidity Ratios
2. Working Capital Analysis

LIMITATIONS OF THE STUDY

- The study was conducted for a period of 5 years.
- The study is done with help of secondary data obtained from the annual reports of the organizations

- The availability of the information and data are limited by time factor.
- There are chances for errors while making calculation

REVIEW OF LITERATURE

Mr. V. Elayabharathi, Mrs. D. Praveena, Mrs. S. Rathika (2019), The study was to analyze the financial stability and overall performance of the TNSC APEX Co-operative Bank. They also interpret the profitability turnover and liquidity or short term solvency position of TNSC Bank. They studied the working capital position of the bank. The study was based on secondary data. They found that the current assets of the concern have been decreased, so they suggested the bank to take steps to meet the short term obligation. They also suggested the bank to maintain proper receivables. They concluded by saying that the performance of the concern was good.

Dr. Seema Thakur (2019), It described on financial performance of DABUR INDIA LIMITED. Secondary data was used to analyze the financial performance and to investigate the financial changes past five years. She ensured optimum operational efficiency by effective utilization of resources the study divulge that the financial performance was very well covered. She concluded that the financial performance was good.

Sabrin, Muhmmad Nur Afiat, sarqiah (2019), The study was to evaluate the financial performance of the company and to analyze the financial position. Based on the study they found that the company pretty good. They suggested to fulfill its obligation of the financial management.

DATA ANALYSIS AND

INTERPRETATION LIQUIDITY RATIO

Liquidity ratios are an important class of financial metrics used to determine a debtor's ability to pay off current debt obligation without raising external capital. These ratios portray the capacity of the business unit to meet its short term obligation from its short-term resources. Liquidity ratio classified into three types

- Current ratio
- Liquid ratio
- Absolute ratio.

CURRENT RATIO

Current ratio may be defined as the relationship between current assets and current liabilities it is the most common ratio for measuring liquidity. It is calculated by dividing current assets and current



liabilities. Current assets are those, which can be realized with in a period of one year.

Current liabilities are those amounts, which are payable with in a period of one year.

$$\text{Current Ratio} = \text{current Assets/ Current liabilities}$$

Table No. 1
Table showing Current ratio
(Rs. in Crores) (Source: Secondary Data)

Year	Current Assets	Current Liabilities	Current Ratio
2014-2015	22,348.85	35,428.75	0.63
2015-2016	17,285.26	35,727.92	0.48
2016-2017	22,857.22	38,761.53	0.59
2017-2018	25,504.43	41,154.37	0.62
2018-2019	26,329.55	48,743.84	0.54

INTERPRETATION

The standard norm of Current Ratio is considered to be 2:1. The current ratio during the year 2014-2015 is 0.63. During 2015-2016 it decreases to 0.48. Later it increases to 0.59 and 0.62 during 2016-2017 and 2017-2018 respectively. During 2018-2019 it decreased to 0.54.

LIQUID RATIO

The term liquidity " refers to the ability of a firm to pay its short-term obligation and when they become due. The term quick assets or liquid assets refers current assets which can be converted into cash immediately and it comprises all current assets except stock and prepaid expenses it is determined by dividing quick assets by quick liabilities.

$$\text{Liquid ratio} = \text{Liquid assets / Liquid liabilities}$$

Table No. 2
Table showing Liquid Ratio

(Rs. in Crores)

Year	Liquid Asset	Current Liabilities	Liquid Ratio
2014-2015	6,304.10	35,428.75	0.18
2015-2016	3,930.43	35,727.92	0.11
2016-2017	4,228.06	38,761.53	0.11
2017-2018	6,892.20	41,154.37	0.17
2018-2019	5,885.93	48,743.84	0.12

(Source: Secondary Data)

INTERPRETATION

The standard norm for Liquid ratio is 1:1. The Liquid ratio during the year 2014-2015 is 0.81. It decreased to 0.11 during 2015-2016 and 2016-2017. The Liquid ratio increased to 0.17 during the year 2017-2018. It decreases to 0.12 during the year 2018-2019.

ABSOLUTE LIQUID RATIO

Absolute liquidity ratio includes cash, bank, and marketable securities. This ratio obtained by dividing cash, bank and marketable securities by current liabilities.

$$\text{Absolute liquidity ratio} = \text{Cash + Bank + marketable securities/ Current liabilities}$$



Table No. 3
Table showing Absolute Liquid Ratio
(Rs. in Crores)

Year	Absolute Liquid Asset	Current Liabilities	Absolute Liquid Ratio
2014-2015	2,235.83	35,428.75	0.063
2015-2016	154.15	35,727.92	0.004
2016-2017	136.4	38,761.53	0.004
2017-2018	1,305.18	41,154.37	0.032
2018-2019	218.5	48,743.84	0.004

(Source: Secondary Data)

INTERPRETATION

The Absolute liquid ratio should be 1:2. The Absolute liquid ratio of HPCL during the year 2014-2015 is 0.063. It becomes gradually decreasing in succeeding years. It decreased to 0.004 during the year 2015-2016 and 2016-2017. Later in next year 2017-2018 it increased to 0.032. During 2018-2019 it decreased to 0.004.

PROFITABILITY RATIO

The profitability ratios of a business concern can be measured by the profitability ratios. These ratios highlight the end result of business activities by which

alone the overall efficiency of a business unit can be judged. (E.g.) gross Profit ratios, Net profit ratios, Operating profit ratio and Operating ratio.

GROSS PROFIT RATIO

This ratio expresses the relationship between Gross profit and sales. It indicated the efficiency of production or trading operation. A high gross profit ratio is a good management as it implies that the cost of production is relatively low.

$$\text{Gross profit ratio} = \left(\frac{\text{Gross profit}}{\text{Net sales}} \right) \times 100$$

Table No. 4
Table Showing Gross Profit Ratio

Year	Gross Profit	Sales	Gross Profit Ratio
2014-2015	13,034.19	216,594.13	6.02
2015-2016	38,231.30	197,964.32	19.31
2016-2017	20,434.82	187,492.89	10.90
2017-2018	218843.64	219,509.64	99.70
2018-2019	23,655.96	275,473.39	8.59

(Source: Secondary Data)

INTERPRETATION

The Goss profit ratio of HPCL during the year 2014-2015 is 6.02. It increases to 19.31 during next year 2015-2016. The Gross profit ratio decreased to 10.90 during the year 2016-2017. The HPCL has the highest Gross profit ratio of 99.70 during the year 2017-2018. It becomes 8.59 during the year 2018-2019.

NET PROFIT RATIO

Net profit ratio establishes a relationship between net profit (after taxes) and sales. It is determined by dividing the net income after tax to the net sales for the period and measures the profit per rupee of sales

$$\text{Net profit Ratio} = \left(\frac{\text{Net profit}}{\text{Net sales}} \right) \times 100$$

**Table No. 5**
Table showing Net Profit Ratio**(Rs. in Crores)**

Year	Net Profit	Sales	Net Profit Ratio
2014-2015	1,488.87	216,594.13	0.69
2015-2016	3,732.42	197,964.32	1.89
2016-2017	5,916.84	187,492.89	3.16
2017-2018	5,896.69	219,509.64	2.69
2018-2019	5,760.90	275,473.39	2.09

*(Source: Secondary Data)***INTERPRETATION**

The Net profit ratio of Hindustan Petroleum Corporation during the year 2014-2015 is 0.69. It gradually increased during next two years. It increased to 1.89 and 3.16 during 2015-2016 and 2016-2017 respectively. Then it gradually decreased to 2.69 and 2.09 during the year 2017-2018 and 2018-2019 respectively.

OPERATING PROFIT RATIO

The operating profit ratio defines the relationship between operating profit and sales.

$$\text{Operating Profit Ratio} = \frac{\text{Operating Profit}}{\text{Sales}} \times 100$$

Table No. 6
Table showing Operating Ratio
(Rs. in Crores)

Year	Operating Profit	Sales	Operating Profit Ratio
2014-2015	4,697.42	216,594.13	2.17
2015-2016	28,333.58	197,964.32	14.31
2016-2017	10,879.66	187,492.89	5.80
2017-2018	10,712.95	219,509.64	4.88
2018-2019	11,567.11	275,473.39	4.20

*(Source: Secondary Data)***INTERPRETATION**

The operating profit ratio of HCPL during the year 2014-2015 is 2.17. It is gradually increases 14.31 during the year 2015-2016. The Operating profit ratio gradually decreases 5.80, 4.88 and 4.20 during the year 2016-2017, 2017-2018 and 2018-2019 respectively.

OPERATING RATIO

The operating ratio defines the association between cost of goods sold and other operating expenses divided by net sales. The ratio evaluated the cost of operations per rupee of sale. **Operating Ratio** = $\frac{\text{Operating Cost}}{\text{Net Sales}} \times 100$



Table No. 7
Table showing Operating ratio
(Rs. in Crores)

Year	Operating Profit Ratio	Operating Ratio
2015-2016	2.17	97.83
2016-2017	14.31	85.69
2017-2018	5.80	94.20
2018-2019	4.88	95.12
2019-2020	4.20	95.80

(Source: Secondary Data)

INTERPRETATION

The Operating ratio of Hindustan Petroleum corporation Limited company is 97.83 during the year 2015-2016 and it decreases to 85.69 during the year 2016-2017. It gradually increases to 94.20, 95.12 and 95.80 during the year 2017-2018, 2018-2019 and 2019-2020 respectively.

FINDINGS, SUGGESTIONS AND CONCLUSION FINDINGS

- The Current ratio is increased the ratio of 0.63 in the year 2014-2015 and decreased 0.48 in the year 2015-2016.
- The Liquid ratio is increased in the ratio of 0.18 in the year 2014-2015 and decreased 0.11 in the year 2015-2016 and 2016-2017.
- The Absolute Liquid ratio increased the ratio of 0.063 in the year 2014-2015 and decreased 0.004 in the year 2015-2016, 2016-2017 and 2018-2019.
- The Gross Profit increased in the ratio of 99.70 in the year 2017-2018 and decreased 6.02 in the year 2014-2015.
- The Net Profit ratio increased the ratio of 3.16 in the year 2016-2017 and decreased 0.69 in the year 2014-2015.
- The Operating Profit ratio increased the ratio of 14.31 in the year 2015-2016 and decreased 2.17 in the year 2014-2015.
- The Operating ratio increased the ratio of 97.83 in the year 2014-2015 and decreased 85.69 in the year 2015-2016.
- Net decrease in working capital is Rs.4,866.51 during the year 2015-2016.

- Net increase in working capital is Rs.1,757.91 during the year 2016-2017.
- Net increase in working capital is Rs.1,893.70 during the year 2017-2018.
- Net increase in working capital is Rs.499.33 during the year 2018-2019.
- The overall performance of HPCL is good.

SUGGESTIONS

- The company can maintain adequate current assets and liquid assets to meet its short term obligation. It can hold up the more funds in the current assets.
- The company can minimize their expenses, so that they can maintain their liquidity position in a safe zone.
- The investment of cash can be increased as it will improve the profitability of the company.
- The company can try to manage its assets efficiency to increase the efficiency of its assets through fixed assets management and working capital management and techniques.
- The company has to focus on the current liabilities which may be settled in right time.

CONCLUSION

Finance is the lifeblood which plays a vital role in the organization and a vital factor for the development of business. Financial performance analysis is used to know the performance of the concern. It is used to know the position of the company. This study is conducted to evaluate the financial performance analysis of HPCL for the period of 5 years ranging from 2014-2015 to 2018-2019.



Examination and explanation of financial statements show that, the present financial position of HPCL has improved quite a lot from the previous years.

The central focus of the study is to conduct an evaluative study of the financial state of the firm by using ratio investigation and financial statement by taking into accounts the past five years of the company's financial statements. To improve a company's liquidity ratio in the long term, it helps to take a look at accounts receivable and payable. Ensure that you're invoicing customers as quickly as possible, and they're paying on time. When it comes to accounts payable, you will want to ensure the opposite-longer pay cycles are more beneficial to a company that's trying to improve its liquidity ratio. Profitability of a company can be increased by reducing costs, increasing turnover, increasing productivity and increasing efficiency. The study concluded that the company financial performance is good.

REFERENCE

1. **Mr. V. Elayabharathi, Mrs. D. Praveena, Mrs. S. Rathika (2019)**, "A Study On Financial Performance with Reference to TNSC Bank, Chennai", *IJARIE-ISSN(O)*, Volume 5, Issue 2, pp.no.2949-2955.
2. **Dr. Seema Thakur (2019)**, "A Study On Financial Performance Analysis of Dabur India Ltd", *International Journal of scientific and Engineering Research*, Volume 10, Issue 9, pp.no. 217-223.
3. **Sabrin, Muhammad Nur Afiat, sarqiah (2019)**, "Analysis of Financial Performance in Lakamali Business Multipurpose cooperative Wangi-Wangi Selatan District, Wakatobi Regency", *IOSR Journal of Business and Management (IOSR-JBM)*, Volume 21, Issue 5, pp.no. 32-41.



A STUDY ON CUSTOMER SATISFACTION TOWARDS SAMSUNG SMART PHONES WITH SPECIAL REFERENCE TO COIMBATORE

Dr. D.Sivasakathi

*Assistant Professor, Department of Commerce with Professional Accounting,
Dr. N.G. P Arts and Science College, Coimbatore*

Banupriya .S

*Student of III B.Com (PA), Department of Commerce with Professional Accounting,
Dr. N.G. P Arts and Science College, Coimbatore*

ABSTRACT

Samsung is the main brand for mobile phones with high-end specification. The main competitor is Apple; however Samsung gives the competitive attention through mobile features. Many customers are loyal to Samsung mobile phones and will continue to develop a relationship with the brand. They are the market leaders. However even with the higher sales in smart phones as compared to its competitor and market leader Samsung is now competing mainly on sales rather than innovation. Finally the customer decision to buy a Samsung mobile phone is based on the quality, new innovation it is easy to browse the internet and better battery life and better service.

INTRODUCTION

Business always starts and closes with customer and hence the customers must be treated as the KING OF THE MARKET. All the business enhancements, profit, status, image etc of the organisation depends on customers. Hence it is important for all the organisation to meet all the customers' expectations and identify that they are satisfied customer. Customer satisfaction is the measure of how the needs and responses are collaborated and delivered to excel customer expectation. It can only be attained if the customer has an overall good relationship with the supplier. In today's competitive business marketplace, customer satisfaction is an important performance exponent and basic differentiator of business strategies. Hence, the more is customer satisfaction; more is the business and the bonding with customer.

Customer satisfaction is a part of customer's experience that exposes a supplier's behaviour on customer's expectation. It also depends on how efficiently it is managed and how promptly services are provided. This satisfaction could be related to

various business aspects like marketing, product manufacturing, engineering, quality of products and services responses customers problem and queries, completion of project, post delivery services, complaint management etc.

STATEMENT OF THE PROBLEM

In the modern business, it is very important to know the preference and satisfaction level of consumers, which help to know how to produce the product. The representation of the brand depends on the consumer's satisfaction towards the product and services. So the customer satisfaction is depends on the features, price, quality level of the mobile and service rendered by company. The problem is to know the satisfaction level and the factors influence the customer to choose Samsung mobile phones.

SCOPE OF THE STUDY

This present study is to analysis the consumer satisfaction toward Samsung mobile



which help to know the level of consumer satisfaction level and to increase the level to attract the consumer toward their brand in future.

OBJECTIVES OF THE STUDY

- To identify customer's opinion about Samsung phones.
- To know about the level of satisfaction of customers towards Samsung mobiles.
- To understand the customer satisfaction level of Samsung smartphone.

RESEARCH METHODOLOGY

Primary data

Primary data is that data which is collected for the first time. It is original data for the purpose of collecting of primary data, questionnaires were filled by the respondents.

Secondary data

It is collected from different articles, journals, and websites.

AREA OF THE STUDY

The study is conducted only in Coimbatore city.

SAMPLE SIZE

In this study, the size of sample is 120 respondents.

SAMPLE METHOD

Sampling is the selection of some part of an aggregate or totality on the basis of which it is made. Convenient sampling is used in this research.

TOOLS FOR ANALYSIS

1. Simple percentage analysis
2. Likert scale
3. Rank analysis

LIMITATIONS

- The research has been restricted to 120 respondents.
- It is limited to collect data through questionnaire.
- Some of the customers are not interested to give information about the product.

REVIEW OF LITERATURE

R. Venkatesh Kumar and K. Tamil Selvi (2017), "A Survey on Customer Behaviour Towards Samsung Mobiles" The study helps the researcher to know the consumer behaviour expectations and their satisfaction level towards Samsung mobile. This study also helps the company to know the major problem faced by the customer in Samsung mobiles. To enhance more consumer

behaviour the company has to consider the suggestion given by the respondents.

Dr. T.N.R. Kavitha and Mr.R. Mohana Sundaram (2014), "A Study on consumer satisfaction towards Samsung mobiles" This study is carried with the objective to determine the customer preference and satisfaction. And this research is conducted on one particular mobile phone brand called Samsung with its quality, price, design and satisfaction. And the customers are being more satisfied by the use of the Samsung mobile phone.

HISTORY AND PROFILE OF THE COMPANY

The Samsung Group is a multinational conglomerate headquartered in Samsung Town, Seoul, and South Korea. It is the world's largest conglomerate by revenue with annual revenue of US \$ 173.4 billion in 2008 and is South Korea's largest chaebol. The meaning of the Korean word Samsung is "Tri-Star" or "Three stars". Lee Byung-chul started "Samsung group" as a trading company at a grocery store in March 1st 1938.

The Samsung group is composed of international affiliated businesses, most of them United under the Samsung Electronics, the world largest electronics company, Samsung Heavy Industries, the world's second largest shipbuilder and Samsung C&T, a major global construction company.

Samsung has been the world's most popular consumer electronics brand since 2005 and is the best known South Korean brand in the world. Samsung group accounts for more than 20% of South Korea's total exports and is the leader in many domestic industries, such as the financial, chemical, retail and entertainment industries.

Samsung group products around a fifth of South Korea's total export and its revenues are larger than many countries GDP. It would have been the world's largest economy. In many South Korean industries Samsung group enjoys a monopoly position. The company has a powerful influence on South Korea's economic development, politics, media and culture and has been a major driving force behind the "Miracle on the Han River. Many businesses today use Samsung's International as a role model.

DATA ANALYSIS AND INTERPRETATION

In this chapter the analysis and interpretation of the "A STUDY ON CUSTOMERS SATISFACTION TOWARDS SAMSUNG SMART PHONES WITH SPECIAL REFERENCE TO COIMBATORE CITY", is presented based on the opinion of sample of 120 respondents selected from Coimbatore city through a questionnaire containing 20 questions were analyzed through



- 1 Simple percentage analysis
- 2 Likert scale
- 3 Rank analysis

describes the classification of the respondents failing each category.

The percentage analysis is used mainly for the standardization and comparisons are support with the analysis.

SIMPLE PERCENTAGE ANALYSIS

Simple percentage analysis is carried out for most of all questions gives in questionnaire. This analysis

FORMULA

$$\text{Percentage} = \frac{\text{Number of respondents}}{\text{Total respondents}} \times 100$$

TABLE NO: 1
TABLE SHOWING AGE OF THE RESPONDENTS

S.NO	AGE	NO. OF RESPONDENTS	PERCENTAGE
1	18years - 27years	45	37.5
2	28years - 38years	43	35.8
3	39years - 50years	22	18.33
4	Above 51years	11	9.1
	TOTAL	120	100

(Source: Primary data)

INTERPRETATION

The above table shows that 37.5% of the respondents are 18 years – 27 years, 35.8% of the respondents are 28 years – 38 years, 18.33% of the respondents are 39 years – 50 years and 9.1% of the respondents are above 50 years.

Majority 37.5% of the respondents are 18 – 27 years.

RANK ANALYSIS

A Rank analysis is any of several statistics that measure an ordinal association, the relationship between ranking of different ordinal variables or different ranking of the same variables, where “ranking” is the assignment of the labels “first”, “second”, “third” etc. to different observation of particular variable. A rank analysis measures of similarity between two rankings, and can be used to assess the significance of the relation between them. It is not necessary a total order of object because two different object can have the same ranking. The ranking themselves are totally ordered.

TABLE NO 2
TABLE SHOWS THAT BASED ON THE RESPONDENTS EXPERIENCE

S.NO	PARTICULARS	1	2	3	4	5	TOTAL SCORE	RANK
1	Good quality	37(5) 185	23(4) 92	28(3) 84	7(2) 14	25(1) 25	400	1
2	Affordable price	9(5) 45	45(4) 180	31(3) 93	26(2) 52	9(1) 9	379	2
3	Timely availability	22(5) 110	25(4) 100	35(3) 105	20(2) 40	18(1) 18	373	3
4	Easy applicability	16(5) 80	16(4) 64	20(3) 60	44(2) 88	24(1) 24	316	4
5	Reliability	38(5) 190	18(4) 72	13(3) 39	16(2) 32	35(1) 35	368	5

(Source: Primary data)

**INTERPRETATION**

The above table shows that Good quality is in the rank 1, Affordable price is in the rank 2, Timely availability is in the rank 3, Easy applicability is in the rank 4, Reliability is in the rank 5

Good quality is in the rank 1 based on the respondents experience of Samsung smart phones.

LICKERT SCALE ANALYSIS

A LIKERT SCALE ANALYSIS is a psychometric scale commonly involved in research employing questionnaires.

Self – reporting is the most widely used approach to scaling responses in survey research. The term is

often used interchangeably with rating scale, or more accurately the LIKERT – TYPE SCALE, even though the two are not anonymous. The scale is named after its inventor, psychologist Rensislikert. Likert distinguished between a scale proper, which emerges from collective responses to set pf items, and the format in which responses are scored along a range. Technically speaking a Likert scale refers only to the former. When responding to a Likert questionnaire items, respondents specify their level of generation or disagreement on a symmetric agrees – disagrees scale for a series of statements. Thus, the range captures the intensity of their feeling for a given item.

FORMULA

$$\begin{aligned} \text{Likert Scale} &= \sum (fx) / \text{Total no of respondents} \\ f &= \text{Number of respondents} \\ (fx) &= \text{Total score} \end{aligned}$$

MID – VALUE

Mid – value indicates the middle most value of Likert scale.

TABLE NO: 3**TABLE SHOWS SATISFICATION LEVEL OF FACTORS IN SAMSUNG SMART PHONES (SOUND EFFECT)**

S.NO	FACTORS	NO. OF RESPONDENTS (f)	LIKERT SCALE VALUE (x)	TOTAL (fx)
1	Highly satisfied	43	5	215
2	Satisfied	40	4	160
3	Neutral	14	3	42
4	Dissatisfied	16	2	32
5	Highly Dissatisfied	7	1	7
	TOTAL	120		456

(Source: Primary data)

$$\begin{aligned} \text{Likert scale} &= \sum (fx) / \text{Total no of respondents} \\ &= 456/120 \\ &= 3.8 \end{aligned}$$

INTERPRETATION

Likert scale value is 3.8 which is greater than the mid value 3, so the customer are satisfied with sound effect of Samsung mobiles.

FINDINDS, SUGGESTIONS AND CONCLUSION**SIMPLE PERCENTAGE**

- 37.5 % of the respondents are 18 – 27 years.
- 55 % of the respondents are Male.
- 56.67% of the respondents are Married.

- 46.67% of the respondents are Graduate.
- 39.17% of the respondents are Private Employee.
- 35% of the respondents are Rs.2,50,000 – Rs.5,00,000.
- 45% of the respondents are choosing Samsung mobiles because of quality.
- 35% of the respondents are influenced by Television.
- 37.50% of the respondents are using Samsung mobile phone from the time period of 6months – 1 year.



- 60.83% of the respondents concerned the affordable of the Samsung mobile phones.
- 34.1% of the respondents are satisfied with the Battery.
- 58.33% of the respondents are saying yes there is difficulties in Samsung mobile services.
- 35% of the respondents are strongly agree with the stylish appearance os Samsung smart phones.
- 45.83% of the respondents are willing to pay between Rs.10001 – Rs.20000
- 70% of the respondents are suggesting to their friend and relatives.
- 27.14% of the respondents are average with the experience of Samsung smart phones.

LIKERT SCALE

- Likert scale value is 3.8 which is greater than the mid value 3, so the customer are satisfied with sound effect of Samsung mobile phones.
- Likert scale value is 3 which is equal to mid value 3, so the customers are neutral with brightness of Samsung mobile phones.
- Likert scale value is 3.3 which is equal to mid value 3, so the customers are satisfied with quality of Samsung mobile phones.
- Likert scale value is 2.7 is equal to mid value 3, so the customers are neutral with clarity of Samsung mobile phones.
- Likert scale value is 2.9 which is equal to mid value 3, so the customers ate neutral with clarity of Samsung mobile phones.

RANK ANALYSIS

- Good quality is in the rank 1 based on the respondents experience of Samsung mobile phones.

SUGGESTIONS

- Because of social influence, people preferring Smartphones but the Samsung phone price is not equal to the phone features is the drawback can be removed by the manufacturers. So that Smartphones customers will be satisfied and good competition will be stayed in the market.
- As there is more emission of radiation from Samsung Smartphones it can be reduced by the manufacturer.
- People who buy Smartphones expecting many features, in Samsung much innovation is already satisfied by customers, improving in innovation of additional features will give a good competition.

CONCLUSION

During the evaluation of smart phones, it acts as a luxury product in due course of time it became the basic necessity of every human. A mobile hand held computer. New generation may be called as mobile phone generation. Mobile phones have become an inseparable part of human. Among the people SAMSUNG is the leading in the mobile industry. Among many of branded mobile phone were perfect SAMSUNG because of its quality and new innovation. And it is easy to browse the internet, best cost control, good battery life and better services. They are the market leaders.

REFERENCE

1. **MS. Neha Kaushal and Dr.O.P. Pathak** "A study on customer buying towards Samsung mobiles". *International Journal of Marketing & Financial management volume 6, Issue 1, Jan – 2018, pp58-62.*
2. **R. Venkatesh Kumar and K.Tamil selvi** "A study on customer behavior towards Samsung mobiles." *International Journal of Marketing Research, volume 5, Issue 3, March 2017.*
3. **Sujatha, J. Surya Narayana Reddy and Y. Surendra Reddy** "A study on factors influencing on customer satisfaction towards Samsung smartphones" *International Journal of Science Technology and Management, volume 6, Issue 1, January 2017.*
4. **Nushart Nahida Afroz** "Students brand preference towards smartphones" *IOSR Journal of Business and Management, volume 19, Issue 2, Feb 2017.*



A STUDY ON CUSTOMER SATISFACTION TOWARDS GODREJ REFRIGERATOR WITH REFERENCE TO COIMBATORE CITY

Mr. S. Muruganantham

*Assistant Professor, Department of Commerce with Professional Accounting,
Dr. N.G.P. Arts and Science College, Coimbatore*

Ms. D. Janani Sri

*Student, Department of Commerce with Professional Accounting,
Dr. N.G.P. Arts and Science College, Coimbatore*

ABSTRACT

In recent days in India, marketing of products and services has become a challenge for the marketers. The study is performed to have an insight on the customer perception towards the initiative provided by Google Appliances. The brand loyal consumer does not attempt any kind of attribute evaluation that simply chooses the familiar brand on the basis of some overall positive feelings towards it. This overall positive evaluation stems from past experience with the particular brand under consideration. Thus, brand loyalty is a function of both behavior and attitudes. The purchase of refrigerators is now a common phenomenon among middle class and customer wants with various admirable features and new brands. Though the financial decision is taken by the main source of income of the family usually men is main source of income in Indian middle-class families the decision regarding colour, brands and the like are taken by women i.e., wife. Corporates are constantly in search of finding a solution for marketing problems. Many researchers have found that it is prudent to retain the existing customers than to create new customers. The current study was conducted in Coimbatore.

KEY POINTS: *Customer satisfaction, buying behavior, brand loyalty, house hold, refrigerators, market competition, quality and service.*

INTRODUCTION

Godrej Groups is established in 1897, it is a leading manufacturer of goods and provider of services in a multitude of categories, is one of the most accomplished and diversified business houses in India today. Godrej properties limited bring Godrej Group philosophy of innovation and excellence to the real estate industry. The Godrej group stands in a strong position today. With annual sales in excess of \$1 billion, a workforce of approximately 18,000, and a strong diversified portfolio, Godrej has proven its ability to deliver strong financial performance.

STATEMENT OF THE PROBLEM

Brand loyalty is the strength of preference for a brand compare to other similar available option. This is often measure in terms of repeat purchase behavior or price sensitivity. The brand loyalty exists

when customer have a high relative attitude toward the brand exhibited through repurchase behavior. This type of loyalty can be a great asset to the firm; customer is willing to pay higher prices, may cost less to serve and can bring in new customers to the company.

OBJECTIVES OF THE STUDY

- To analyze the media preference of customer.
- To identify the various factor influencing the customer satisfaction of Godrej Refrigerator.
- To know the satisfaction level of Godrej user.
- To find out the effectiveness of the salesman services.

**SCOPE OF THE STUDY**

The present study has been made to analyses to the customer satisfaction towards Godrej refrigerator in Coimbatore city. The study contains customer satisfaction towards the various products of Godrej refrigerator in Coimbatore city through the main objective of customer by using the Godrej products, but the scope of study extends to the following related aspects viz. customer awareness of the product and find the factor which is influencing the product of choice.

RESEARCH METHODOLOGY

Research methodology is the systematic way to solve research problem. It is a science of studying how research is to be carried out. Its aim is to give work plan of research. The study is based on a survey collected in Coimbatore with the help of primary and secondary data.

DATA USED: Primary data and Secondary data are used.

AREA OF THE STUDY: The study was undertaken in Coimbatore city.

SAMPLE SIZE: The study was conducted with a sample size of 120 respondents.

ANALYTICAL TOOLS USED: Simple percentage, Likert scale analysis, Ranking Analysis

REVIEW OF LITERATURE

P. Sathya, S. Rethinapriya & S. Balasundhari (2019) Studied to analyse the satisfaction level of customer with reference to whirlpool home appliances. Customer is the individual or organization unit that consumes a product. Customers and the Centre point and also king of the market. The manufacture must keep a constant touch with the customer. He must plan his production and distribution to suit the customer's convenience rather than his own. The suggestion given in the study if implemented shall definitely help strengthen its stake in the market.

Dr. M. Ganesan & Dr. S. Chandramohan (2019) Studied that the aim of the present study is to gain knowledge about the different factors which contributes to the satisfaction of the customers. Household electronic products like television, mobile phone and refrigerator etc., are being used by each and every household in our society. These products have become art and parcel of our daily life. As these products were taken up for this study, the result of the study brings out so many facts

ANALYSIS**TABLE SHOWING RESPONDENTS TIME OF PURCHASE**

S.No	Factors	No. of Respondents	Percentage (%)
1	Discount Offers	30	25
2	Arrival of New Models	42	35
3	Free Gift	25	20.83
4	Anytime	23	19.17
	Total	120	100

INTERPRETATION

The table shows that 25% of the Respondents Purchased at Discount Offer, 35% of the

Respondents Purchased at Arrival of New Models, 20.83% of the Respondents Purchased at Free Gift, 23% of the Respondents Purchased at Anytime.

TABLE SHOWING DISTRIBUTION OF RANKING PERFORMANCE TOWARDS GODREJ REFRIGERATOR

S.No	Factors	1	2	3	4	5	Total	Rank
1	Durability	30(5)	23(4)	39(3)	17(2)	11(1)	404	1
2	Style & Design	22(5)	18(4)	36(3)	29(2)	15(1)	363	3
3	After Sale Service	28(5)	26(4)	18(3)	28(2)	20(1)	374	2
4	Electricity consumption	20(5)	20(4)	12(3)	30(2)	38(1)	314	5
5	Brand reputation	20(5)	33(4)	15(3)	16(2)	36(1)	345	4

INTERPRETATION

From the table, it is understood that Durability is Ranked 1, After Sale Service is Ranked 2, Style &

Design is Ranked 3, Electricity Consumption is Ranked 4, Brand Reputation is Ranked 5.



FINDINGS

1. SIMPLE PERCENTAGE METHOD

- Majority (54.17%) of the Respondents are Female.
- Most (47.50%) of the Respondents are in the Group of 21 to 30 Years.
- Majority (56.67%) of the Respondents are UG.
- Majority (61.67%) of the Respondents are Married.
- Most (35%) of the Respondents are at Private Employee.
- Majority (76.67%) of the Respondents are in the Family of 3 to 6 Members.
- Most (49.17%) of the Respondents having Annual Income of Rs.2,00,001 to Rs.3,00,000.
- Most (28.33%) of the Respondents consider Brand Reputation of Godrej Refrigerator.
- Most (47.50%) of the Respondents are came to know about Godrej Refrigerator from Advertisement.
- Most (47.50%) of the Respondents have been Using the Godrej Refrigerator for 5 to 15 Years.
- Most (40%) of the Respondents Using 201 to 300 ltr Capacity of Refrigerator.
- Most (33.33%) of the Respondents Motivated by Friends to Buy Godrej Refrigerator.
- Most (35%) of the Respondents Purchased at Arrival of New Models.
- Majority (70%) of the Respondents Pay their Payment as Credit.
- Majority (65.83%) of Respondent Feels that the Price of Godrej Refrigerator is Moderate.
- Majority (51.67%) of the Respondents Strongly Satisfied by Quality of Refrigerator.
- Majority (75.83%) of the Respondents does not Faced Problems After the Usage of Godrej Refrigerator.
- Majority (84.17%) of the Respondents will not Switch to Another Brand in Future.
- Majority (84.17%) of the Respondents Recommend Godrej Brand to Another Person.

2. RANKING ANALYSIS

- The Durability has been Ranked 1st by the Customers towards Performance of Godrej Refrigerator.

3. LIKERT SCALE ANALYSIS

- Likert Scale value 4.13 is Greater than the Mid Value (4), thus the Respondents are Satisfied with the Durability of the Godrej Refrigerator.

SUGGESTIONS

- Source of information reveals; family members and friends have given many tips to select the brands. Hence it is suggested that an attractive advertisement should be displayed in Television and placing Hoardings in the main junctions will help the prospective buyers to select a Godrej Refrigerator.
- The refrigerator company should also facilitate with suitable spare parts for their products in case of damages
- It is suggested that the reasons for the switch over should be identified and try to retain the customers with Godrej brand through augmented services

CONCLUSION

In this study numbers of participants were 120 and on analyzing the customer satisfaction of Godrej refrigerator has benefits and limitations. Consumers are now able to compare many features in the commodities like quality, price, and value for money, service, durability and brand image etc., If the company produces high quality refrigerators, loyalty on particular company brand of refrigerators become much easier to the customer. Godrej refrigerator make effort to supply goods at reasonable price, improve the after sale service facilities and provide suitable spare parts to the customer. However these firms should give care to attend the problems and after sale service be improve to retain their respective market share.

REFERENCES

1. P. Sathya, S. Rethinapriya & S. Balasundhari (2019), "A Study on Customer Satisfaction towards selected Whirlpool Home Appliances with Special Reference to Pattukkotta", ISSN NO:2236-6124.
2. Dr. M. Ganesan & Dr. S. Chandramohan (2019), "A Study on Customer Satisfaction of House Hold Electronic Products in Sivagangai District", ISSN:2348-1269.
3. C. Kalamani & K.V. Shanmugavadivu (2015), "A Study on Customer Satisfaction towards Butterfly Home Appliances with Special Reference to Erode", ISSN NO:2279-0837.
4. M.J. Senthil Kumar, Dr. K. Sadeesh Kumar & Dr. N.R. Nagarajan (2013), "A study on consumer's attitudes towards Washing Machine", ISSN NO:2249-2585.



A STUDY ON PASSENGERS PERCEPTION TOWARDS THE AIRLINE INDUSTRIES WITH SPECIAL REFERENCE TO COIMBATORE CITY

Mr.P.Kanagaraj

*Assistant Professor, Department of Commerce with Professional Accounting
Dr. N.G.P Arts and Science College, Coimbatore.*

M. Sowmiya

*Student of III B.Com (PA), Department of Commerce with Professional Accounting
Dr. N.G.P Arts and Science College, Coimbatore*

ABSTRACT

Air transport being the most and the quickest mode of transport have been gaining popularity. However, the exorbitant rates have made it the mode of travel of the rich or of the business community for whom time is more expensive than air travel. The main objective of the study was to find out the customer satisfaction in airways in various objects like price, quality, services & source of booking.

KEYWORDS: *Customer satisfaction, Airline, Booking, Quality, Service provided.*

INTRODUCTION

The Coimbatore airline industry not only improvised its passengers traffic but also on the safety issues, consumer satisfaction of the passengers. The quality of services given by the airline industry is at the high level, and so it was given an international status in 2012. It provides services not only within the country but also all around the neighbour countries like Nepal, Bangladesh, Pakistan, Afghanistan, Sri Lanka, Myanmar and Maldives. The various flights operating in Coimbatore are Air India, Spice jet, Air Arabica, Indigo, etc. There is a long range of reputation and priority for the airline industry in the Coimbatore city and also for the persistent passengers satisfaction.

OBJECTIVES OF THE STUDY

- To study the passengers perception towards airlines in the Coimbatore city.
- To find out the satisfaction towards airlines in the Coimbatore city.

STATEMENT OF THE STUDY

Excellent passenger satisfaction is one of the greatest assets for an air business in today's environment. Passengers gratification is essential goal for each airline proving passenger service.

Hence it is expected to know the passenger preference and satisfaction towards the various services provided by the airline industry. A study has been carried out on the topic "A study on passenger perception towards airline industry". As the passenger has a wide choice to select suitable airline according to their requirements.

SCOPE OF THE STUDY

A high quality service is the corner stone of any successful service industry, Which is why marketing strategies implemented by airlines to expand internationally must take into account the different expectations and perceptions of passengers. The purpose of the study is to identify the preference and satisfaction of passengers in airline industry with special reference to Coimbatore city. This study evolves the significance of highly preferable airlines in Coimbatore. Hence this study shows the satisfaction in airlines as Indigo, Spice jet, Air India and Alliance air.

RESEARCH METHODOLOGY

The Study includes both primary and secondary data.

- Primary data have been collected from the target respondent through structured



questionnaire.

- Secondary data have been collected from different source as Journals, Internet and website

AREA OF THE STUDY

The study is undertaken in Coimbatore city.

SAMPLE AND SAMPLE TECHNIQUES

A sample of 150 respondents has been chosen by using purposive sampling technique.

TOOLS USED

- Simple percentage method
- Chi-Square method

LIMITATION OF THE STUDY

- The sample respondents may not represent the entire population.
- The study is pertained for short period, so the time may change the attitude of the Passengers.

REVIEW OF LITERATURE

Harunyilmaz and Cevbor yuksei (2017)⁴ have made a study on, “Researching the satisfaction level of passengers for security services at Airports”. The objectives of the study is to understand the importance of safety in Aviation and to make it sustainable by analysing effect on

passengers satisfaction. 536 questionnaire were applied both face to face and online to the passengers using Turkish Airports. The statistical tool t-test ANOVA and Regression analysis is used to analyse the Data. This study found out that there is the meaningful association between the evaluation of the passengers towards securities services at the airports and their satisfaction level. It also evaluates of the passengers towards security services at the Airports and their satisfaction level differ according to the flight frequency.

Amuthanayaki (2016)¹¹ has conducted a study on, “Air passengers level of expectation and satisfaction towards airline services with special reference to Coimbatore city” The objective of the study is to identify the prevailing gap between air passengers, level of expectation and satisfaction towards airline services. Eight service providers are taken as sample and a small sample consist of 30 respondents. The statistical tool weighted arithmetic mean is used to analyze the data. The result of the study shows that , as middle class people are mostly avoiding air transport because it is still expensive. The study emphasis to enhance the service quality and try to reduce the prevailing gap between air passengers expectation and final level of satisfaction.

SIMPLE PERCENTAGE ANALYSIS

Simple percentage analysis is the method to represent raw streams data as a percentage for better understanding of collected data.

$$\text{Percentage} = \frac{\text{Number of respondents}}{\text{Total no. of respondents}} \times 100$$

Table showing the Gender of respondents

Gender	No of respondents	Percentage
Male	80	53.3
Female	70	46.7
Total	150	100

(source: primary data)

INTERPRETATION

The above table reveals the gender of respondents is noted that 53.3 per cent of the respondents are male and female contribute 46.7 percent.

53.3per cent of the Respondents are Male.

**AMOUNT SPENT FOR TICKET PER TRAVEL****Table showing Amount spent for Ticket per Travel**

Amount spent	No of respondents	Percentage
Below Rs.2,000	26	17.3
Rs.2,000 – Rs.3,000	55	36.7
Rs.3,001 – Rs.4,000	27	18.0
Above Rs.4,000	42	28.0
Total	150	100

*(source: primary data)***INTERPRETATION**

Table shows that 36.7 per cent of the respondents have spent an amount between Rs.2,000 - Rs.3,000 for ticket per travel, 28 per cent of the respondents have spent above Rs.4,000 for ticket per travel, 18 per cent of the respondents have spent an amount between Rs.3,001 - Rs.4,000 for ticket per

travel and 17.3 per cent of the respondents have spent below Rs.2,000 for ticket per travel.

36.7per cent of the respondents have spent an amount between Rs.2,000 – Rs.3,000 for ticket per travel.

CHI-SQUARE TEST**Formula :**

$$\chi^2 = \sum \frac{(O_i - E_i)^2}{E_i}$$

Table showing Age of the respondents VS Preference towards travel class

Age of the respondent	Preference towards travel class				Total
	Economy class	Premier class	Business class	First class	
Below 20 years	17	3	5	8	33
20-30 years	35	10	3	6	54
36-50 years	36	21	3	2	62
Above 50 years	1	0	0	0	1
Total	89	34	11	16	150

*(source: primary data)***INTERPRETATION**

The Chi square test reveals that out of 54 respondents of age group between 20-35 years, 35 have preferred Economy class, followed by 10

respondents have preferred Premier class,6 respondents have preferred First class, and 3 respondents have preferred Business class.

	Value	Df	Asymp. Sig. (2-sided)
Pearson Chi-square	20.282 ^a	9	0.016

From the above table it is shown that, the calculated value is 20.282 is greater than the table value 16.92. since the calculated value is greater than the table value at 5 per cent level of significance there is an association between age of the respondents and

preference towards travel class. Hence the null hypothesis is rejected.

**Table showing Occupation of the respondents VS Preference towards travel class**

Occupation of the respondents	Preference towards travel class				Total
	Economy class	Premier class	Business class	First class	
Student	15	7	1	6	29
Self-employed	8	6	1	4	19
Salaried	13	4	0	1	18
Professional	42	11	8	5	66
Home maker	9	6	1	0	16
Others	2	0	0	0	2
Total	89	34	11	16	150

*(source : primary data)***INTERPRETATION**

The Chi square test reveals that out of 66 professionals, 42 respondents have preferred Economy class, followed by 11 respondents have

preferred Premier class, 8 respondents have preferred Business class, and 5 respondents have preferred First class.

	Value	Df	Asymp. Sig. (2-sided)
Pearson Chi-square	18.144 ^a	15	0.255

From the above table it is shown that, the calculated value is 18.144 is lesser than the table value 25. Since the calculated value is lesser than the table value at 5 per cent level of significance there is no association between occupation of the respondents and preference towards travel class. Hence the null hypothesis is accepted.

FINDINGS**SIMPLE PERCENTAGE ANALYSIS**

- 53 per cent of the respondents are male.
- 41.3 per cent of the respondents age group is between 36-50 years.
- 66 per cent of the respondents have completed professional qualification.
- 44 per cent of the respondents are professionals.
- 36 per cent of the respondents family income is above 50,000 per month.
- 45.3 per cent of the respondents are travelling in airlines rarely.
- 46 per cent of the respondents have chosen to travel with their family.
- 59.3 per cent of the respondents usually travel in economy class.
- 38.7 per cent of the respondents are booking tickets through online apps.
- 45.3 per cent of the respondents said that the time taken at boarding gate is less than 10 minutes.
- 58.7 per cent of the respondents said that

the time taken at security check points is also less than 10 minutes.

- 94 per cent of the respondents are satisfied with the services of air hostess.
- 94.7 per cent of the respondents are getting proper guidance from the airlines.
- 50.7 per cent of the respondents said there is delay in the arrival/departure of flights.
- 72.7 per cent of the respondents have no problems while their travelling.
- 43.9 per cent of the respondents choose to prefer Spice jet airline.
- 35.2 per cent of the respondents prefer Spice jet for safety.
- 29.1 per cent of the respondents least prefer Alliance air airline.
- 33.5 per cent of the respondents doesn't prefer Alliance air airline because of its higher price.

CHI-SQUARE

- The Chi-square test reveals that there is a relationship between age of the respondents and preference towards travel class.
- The Chi-square test reveals that there is no relationship between occupation of the respondents and preference towards travel class.
- The Chi-square test reveals that there is no relationship between educational qualification of the respondents and



preference towards travel class.

- The Chi- square test reveals that there is no relationship between family income of the respondents and preference towards travel

SUGGESTIONS

- Passengers have faced problems in departure and arrival of flight. So airlines should ensure that there is no delay in departure and arrival of flight.
- The airlines should reduce the ticket price by giving offers or discounts.
- Passengers should be provided with more in-flight services like quality of food and drink, seat comforts, baggage handling, cabin cleanliness etc., which will attract the Passengers to prefer the same airlines in the near future.

CONCLUSION

A study on passengers perception towards airline industries with special reference to Coimbatore city has been carried out and it reveals that passengers are satisfied with the quality, service and safety provided by the airlines. By providing more discounts and concessions on tickets and exhibiting new ideas to satisfy passengers, can improve the air passengers. Passengers have faced problems in departure and arrival of flight. Hence, airlines should ensure that there is no delay in departure and arrival of flight. Passengers service quality is the key success for airline industries. By improving passengers' service, it automatically leads to the growth of airline industries. It is concluded that, Passengers are getting high value for their money and satisfied with overall courteous and helpfulness of airline industry.

REFERENCES

1. **Harun Yilmaz and Cevhor Yuksei** "Researching the satisfaction level or passenger for security services at airports, *International Journal or marketing studies volume-9 no.5/ ISSN 1918-7203 (2017).*
2. **Amuthanayaki**, "Air passengers level of expectation and satisfaction towards airlines services (with special reference to Coimbatore city), *International Journal of Management and commerce innovations, ISSN 2348-7585/volume 4/ issue 1/p.p:142- 150/ (April- September 2016).*



THE PLACE OF LETTERS IN ABDULLA QODIRIY'S COMICS

Tursunova Faridahon Ganievna¹

¹*a Senior Teacher of "The Uzbek Language and Literature" Department, "Management in Production" Faculty, Ferghana Polytechnic Institute, Uzbekistan, Ferghana*

ABSTRACT

The article under discussion depicts the place of comics in Abdulla Qodiriy's letters. The author of the article considers that in the comics of Abdulla Qodiriy we see the effective use of the epistolary monologue in order to increase the effectiveness of the work, to express in more detailed way unspoken thoughts of the protagonist. When we talk about the epistolary form of speech, we first consider it appropriate to dwell on the meaning of the word "epistolary."

KEY WORDS: *comics, epistolary, speech, personal, storytelling, protagonist, method, absentee, meaning, word.*

DISCUSSION

Abdullah Qodiriy refers to letters a lot throughout his career. Letters are a form of epistolary speech. In the comics of the writer we see the effective use of the epistolary monologue in order to increase the effectiveness of the work, to express in more detailed way unspoken thoughts of the protagonist. When we talk about the epistolary form of speech, we first consider it appropriate to dwell on the meaning of the word "epistolary."

"Epistole" is a Greek word meaning "to write essays, to write". The epistolary method is a letter sent by the protagonist to someone, which is written in the form of an absentee address to the interlocutor. M. As Bakhtin points out, "first-person language is one of the manifestations of storytelling".

Epistolary speech is a type of speech used in personal correspondence, letter writing. This type of speech will be intended for the general public rather than for a specific person. Through epistolary speech, a person's inner world, his emotions, the problem of self-awareness, but at the same time, the fate of the main characters, the secrets of daily life are revealed and allows the author to defend himself.

The letters show how fast the writer puts the reader face to face with his thoughts, feelings, and

moods. Letters allow the teacher to create character traits, a wide range of interests, a personal attitude to events. They reflect changes in the writer's destiny, attitude, emotional mood.

Typically, letters are designed to report something and are expressed in the form of a written request. The letters are the inner monologue of the protagonist and play an important role in depicting the spiritual world of the characters. The following is an analysis of a series of letters from Julkunboy from Moscow:

In his letter "Moscow Letters I", Abdulla Qodiriy describes in a peculiar way that his compatriots, who went to Moscow on trade issues, were engaged in unscrupulous activities. He wrote: "...ундан бунга совдо-сотик учун келиб, қаёқдаги тутуруқсиз шилинпоча гўзаллардан шатта еб, Масков кўчаларида саланғлашиб юрган каммерсант акаларимизнинг ҳаётидан ёзайми". [2]

"Moscow Letters II" is logically a continuation of the first letter, continuing the issues raised in the first letter. In particular, he said to his "compatriots" being guests there, who considered themselves strangers, and who took a "woman in their arms" and went on an evening pilgrimage, "Oh, you



who have prayed five times, let your prayers beat your liver," I said: "Эй, ўқуған беш вақт намозинг жигарингдан урсун-дедим ва давом этдим. Эй, туткан рўзанг, ўғирган тасбеҳинг муччангдан урсун-дедим" ("Let your rosary strike from the dust".) Such a bitter irony, the cuts show that the writer hates what his compatriots do. In addition, the statements of Turkestan, which filled the city streets, and their behavior are described in the letter in a very beautiful, clear, truthful way. [2]

It is clear that the first and second letters are the result of adaptation to new conditions, learning and observing new people. Exactly the first "strange" and torturous events were recorded. Qodiriy will continue this situation in his later letters.

"Moscow Letters III" covers the periodicals published mainly in Turkestan and throughout Tsarist Russia. The writer overthrew the Turkiston newspaper and in the 327th issue of the newspaper he saw Elbek's poem "To the Tekinhorlar":

Талаб олмоқ сизларга кўбдан қолма одатдир,

Аммо талаб егувчи, бизча, ёлғиз бир итдир.

Кимки талаб теп-текин еса, билгил, ҳаромдир,

Ҳаромнида егувчи яна ёлғиз бир итдир.

It is not uncommon for you to demand,

But the demand-taker, in our opinion, is a lonely dog.

Whoever is free from demand is knowledgeable, unclean,

The harem eater is again a lonely dog.

Abdullah Qodiriy writes a parody of "Elbek's fiery speech against this call":

Сўксанг сўккил, урсанг урғил, ёлғиз санинг итингман,

Кирлик таниннга кирган бўрдоқидек битингман.

Ҳаром танга ҳаром бит, аватиға чавати,

Қичинманғиз, сапчиманг, тинчроқ туринг, бир сўрай! [2]

If you swear, swear, if you hit, hit me, I'm your only dog,

I'm done like a fat man with a dirty body.

Haram bit the haram body, avatiga chavati,

Don't itch, don't jump, stay calm, ask! [4.

Page 245]

Through such a poisonous pitching letter, the writer ruthlessly criticizes the plight of the helpless people and the leaders who are starving for free food.

In the series of letters "Moscow Letters IV", the author raises a number of issues, using a unique method of description. Focuses on issues related to the Bukhara University in Moscow. The letter consists of three parts, the first of which is entitled "Madhal: The Flu and the Philosophy of the Three" and focuses on issues related to the Bukhara School in Moscow: "... the fact that his beard is two years old, despite his age; hire four prikazchik with one box; trembling of the abdomen with a glistening surface; The fact that it has a number but no weight is one of the factors for the flu and all three."

It is obvious that although the educational institution looks like an authoritative educational institution from the outside, it is empty, its staff is worthless, and the problems of the time that bring up countless uneducated young people to the society are covered.

The second part describes the dormitory life, the problem of flaps and fleas, the effects of humidity, the condition of the students of the school. This part is called "Introduction: Old girl, cry on your forehead": "For some reason, a desert frog squawked on the floor, and as I rubbed my hand on my face, a couple of squirrels fell from the salty wall ..." We, the Turkestans, have eleven wooden houses, nine hungry awnings and a real estate, a yellow cow, a flat cauldron, a barn, and so on. [2]

The third part is called "End: The value of a donkey's fall." This third section also continues these problems and seeks to shed as much detail as possible:

- Where are these children born, in Bukhara or Moscow?

- In Bukhara.

- How did they come?

- In their blankets.

- What are they going to do?

- They want to study.

"Are their mothers with me?" I asked, and walked forward, deceiving the children who were crawling under my feet. As soon as I lay down in front of the door, seven or eight girls, who were sitting in the middle, suddenly stopped singing and sang "Don't Cry Half" [2]

In the fourth letter, Julqunboy takes his compatriots, who came to study, as the main topic and describes that they have not left their "breast milk", in which case it is very difficult to get an education. These afflictions that tormented him continue in the fifth letter.

The letter in the "Moscow Letters V" series describes the situation of hungry children who moved to Moscow and waited for money in the post office day



and night: "Yes, by the way, tonight your children were in a critical condition due to food shortages. Through these images, Abdullah Qodiriy worries about the futility of the lives of children who come to school and offers a unique way to send money: "Say yes, even if you buy three or four cans of cotton, calm them down, Dad! The cotton is ripe!" [2]

Through his letters, Abdullah Qodiriy sheds light on important issues of his time. The main reason for studying his letters is his creative personality. It is only in the letters that the creative personality is revealed.

When it comes to the personality of the creator, his talent, eloquence, encyclopedic knowledge, sharp observation, deep intellect, high artistic level, inner feelings, observant conscience, faith, knowledge of his native language are seen by the world. The creative personality literally shows itself in his letters.

In short, Abdullah Qodiriy covers important issues of his time through his letters. Through the above series of letters, the creative personality is revealed. The personality of the writer literally shows itself in these letters. In these letters, the writer not only records the events of life in a simple way, but also makes extensive use of imagery as the main tool of literature as a specific means of knowing and influencing life.

Through the letters in Julqunboy's work, we understand that the writer is talented, witty, sharp-sighted, has a deep intellect, a high artistic level, is observant, conscientious, faithful, humane, knowledgeable of his native language.

The peculiarity of epistolary speech in the creation of humorous character is that this type of speech is not limited, in which the writer through ten written wishes reveals the shortcomings of education, press, culture, religion, problems of concern, cuts, pitching, poisoning. using tone to harshly criticize irresponsible government leaders.

The writer uses the epistolary form of speech in the creation of a humorous character, showing the growth and change in the human mind and psyche with changes in social environment, conditions, the ideas of the nation's destiny, unity, national grief, independence, individual freedom, struggle for social justice. revealed the aims and ideas of Jadid literature, which sought to change the way of life and the spiritual world of the people. The humorous critique in this work is to expose social evils such as backwardness, ignorance, and colonial oppression, which are understandable to the public, and whose negative state is seen when measured by universal criteria.

Epistolary speech is designed to convey something and is expressed in the form of a written appeal. This form of speech is the inner monologue of the protagonists and is used to describe the spiritual world of the characters.

Abdullah Qodiriy illuminates important issues of his time through epistolary speech. His sharp gaze was able to see many shortcomings in society, and his ability to reflect these problems in his works in a unique way.

REFERENCES

1. Solijonov Y. *Poetics of artistic speech in Uzbek prose of the 80-90s of the XX century.* Tashkent. 2002
2. Qodiriy A. *Diyori bakr.* Tashkent. Info Capital Group Publishing. 2018 P.p.248-264



IMPROVING THE MECHANISM OF PERSONNEL MANAGEMENT IN THE CONDITIONS OF THE DIGITAL ECONOMY

Yakubov Valijohn Ganievich¹

¹A Senior Teacher of "Accounting and Audit" Department, "Management in Production" Faculty,
Ferghana Polytechnic Institute, Uzbekistan, Ferghana

Shohev Davronbek Ahmadjonovich²

²A Teacher of "Accounting and Audit" Department, "Management in Production" Faculty,
Ferghana Polytechnic Institute, Uzbekistan, Ferghana

ABSTRACT

The issues of digital economy have become urgent due to qualitative changes in economy and society. New technologies and platforms allow managing enterprises and individuals to reduce transaction costs of interaction on a large scale and to make closer contact with economic objects and state structures. The result is an economy based on network services, i.e. digital or electronic. The concept of "digitalization" testifies to a new stage of improvement of management of production of goods and services and the production itself on the basis of application of modern information technologies, starting from the Internet of things and finishing with technologies of electronic government. The main reason for the expansion of the digital economy is the growth of the sector in terms of information collection costs.

KEYWORDS: *digital employment, digital economy, information and communication technologies, transformation of the labor market, "digitalization".*

DISCUSSION

Most developed countries have national strategies and programs to digitalize the economy and society. The goals and objectives are generally similar, but the approaches to implementation differ. Some of the initiatives are built into the broader scientific, technological and innovation agenda, which is currently being noted by domestic experts.

Based on foreign experience, we can safely assert that this process initiated by the President of Uzbekistan is capable of bringing all directions, including science, to a new level.

Today, the study of global trends and global opportunities in the development of digital economy (DE), as well as informative communicative technology (ICT), is becoming particularly important in the country. Further prosperity, the prospects of

the state and success of large-scale reforms largely depend on the introduction of innovations.

Existing digital initiatives usually have a clear continuity and are based on the results of previous ICT strategic and policy documents. In most countries, the development of first strategies in this area dates back to the late 1990s and early 2000s. Leader countries are now moving to the next stage, which is the launch of pilot programs to introduce digital technologies into industry.

The main objectives are the digital transformation of public administration, development of information and communication infrastructure based on technology, strengthening information security, development of digital skills and competencies. Accordingly, special attention is paid to regulatory aspects related to the construction and use of broadband network infrastructure.



Transition to digital technologies also contributes to strengthening competitiveness of national economies. Taking into account the spread of digital platforms at the international level, special attention is paid to the norms and rules that guarantee the diversity of technological solutions and equal conditions of competitive environment.

The main prerequisite for the success of the policy of digitalization specialists call the coordination of actions and continuous communication of authorities, business, scientific, educational and expert communities. Special attention is paid to monitoring and evaluation of the effectiveness and efficiency of measures taken.

It is also interesting that the dynamics of development in the digital age is provided not only by new technological companies and enterprises: in the world already more than 75 percent of the added value falls on traditional industries due to increased productivity through the use of the Internet.

Experience shows that DE is the power to accelerate global growth, create new markets and infrastructures. It also offers great opportunities for inclusive and sustainable growth. However, this development is being accelerated by those countries and alliances that are systematically building leadership frameworks and mechanisms.

The development of digital economy is widely researched and in Uzbekistan today the three-year strategy of development of electronic government is adopted, a number of projects on introduction of "smart" and "safe" cities and regions on the basis of processing of big data and introduction of the Internet of things, and also intellectual systems of supervision and monitoring in public places are realized [1].

In Uzbekistan, it is planned to increase the export volume of software products by 10 times within five years, bringing the share of the sector in GDP to 4% [4]. Development of the state program on development of information technologies and communications for the long-term perspective has started. At present, issues related to the impact of digital economy on the transformation of the labor market, especially in the sector of medium qualification, are being considered in Uzbekistan. To date, measures are being developed to improve the system of human capital development, including education and training of personnel, stimulating the interest of young people in natural sciences, creating an ecosystem favorable for the development of digital skills of the population [3].

The legal framework is also being strengthened. The President of Uzbekistan noted the important tasks. Among them the development of the program "Digital Uzbekistan-2030", which envisages renewal of all sectors of economy on the basis of digital technologies, increase of share of digital

economy in GDP by at least 30 percent, due to which corruption will be reduced. It also envisages implementation of "One Million Programmers" project with foreign partners for further acceleration of works on development of science and DE and training of highly qualified specialists in this field.

The development of digital technologies, robotization and automation should become the basis for forecasting the development of the division of labor and the transformation of professions and labor content. This, in turn, is the basis for predicting the development of the labor market and employment, hence the requirements for education and competence formation. From the practical point of view, it is necessary to assess the effectiveness of the applied methods of vocational guidance and professional self-determination in terms of their compliance with the requirements of the industrial revolution, the prospects for the development of the labor market, forms of employment [1].

Career planning systems are more focused on personnel retention in the organization, rather than on the free movement of a person on the labor market, which generates contradictions of personal and professional character, hinders the development of human resources of the country. Therefore, it is necessary to develop a concept that allows to overcome these contradictions and to form a single theoretical basis for the construction of a modern promising system of career guidance and professional self-determination, integrating the efforts of different actors to achieve common goals. The scientific idea of this concept is to consider career guidance and professional self-determination as a mechanism to ensure the unity and continuity of the process of reproduction of human resources from the point of view of human choice of his trajectory of professional development, which is due to the transversal nature of changes in the technological, professional and functional division of labor under the influence of the principles of the fourth industrial revolution, digital economy and innovative character of social and labor relations.

One of the key elements of public policy should be the training and retraining of personnel. In this context, the educational system and infrastructure will need to be adapted to the new requirements of the digital age. In particular, it will be necessary to introduce fundamentally new approaches to education and ensure a high level of basic digital literacy among the population.

The personnel management system includes strategic, tactical and operational methods to ensure maximum compliance between their capabilities, on the one hand, and on the other hand the goals and conditions of the organization's development. Through the use of labor, experience and intuition of the staff, the goals of the organization are achieved.



This is possible if the interests of the firm and the employee are coordinated, if an individual is satisfied with the work [3].

Competitiveness of the personnel is an aggregate competitiveness of individual employees or their groups. Employee competitiveness is the ability to achieve individual achievements in work that contribute to achieving organizational goals. This contribution depends on the correspondence of organizational goals to individual goals. In addition, an individual employee's competitiveness depends on the functions he or she performs. It should be emphasized that an employee's contribution to the competitiveness of an organization may be either positive or negative if the psychological climate and corporate culture of the organization are incompatible with the values of the individual. Thus, an employee may be characterized by high competitiveness within one process, one organization and low competitiveness within another.

To manage the competitiveness of employees in the digital economy requires a system of diagnostics of competencies, psychological characteristics, personal values and their compliance with corporate culture, based on formal and informal information sources. In addition, it must be dynamic and adaptive - monitor deviations in staff competitiveness from the specified parameters and offer activities in the field of professional development, career growth and development, correction of the emotional background of the personality and improvement of the psychological climate of the staff. These factors necessitate the use of machine learning in creating HR management systems and the competitiveness of employees in the digital economy.

To manage the competitiveness of employees in the digital economy requires a system of diagnostics of competencies, psychological features, personal values and their compliance with corporate culture, based on formal and informal information sources. In addition, it must be dynamic and adaptive - monitor deviations in staff competitiveness from the specified parameters and offer activities in the field of professional development, career growth and development, correction of the emotional background of the personality and improvement of the psychological climate of the team.

According to expert agencies, most modern companies on the Fortune 500 list use machine learning in various business processes - creating innovative products in Google, Microsoft, Apple, Amazon; managing user-generated content in Google, Pinterest, Yelp, NextDoor, Disqus; e-commerce in Lyst and Trunk Archive, helping users to find relevant information in Google, Rich Relevance and Edgecase. Machine learning is used

by large companies for predicting consumer behavior and customer service.

Machine learning algorithms allow to optimize personnel management processes and minimize associated costs as well as the damage associated with hiring inappropriate candidates caused by human error in the recruitment process.

HR management includes the following activities [4]:

- finding the right employees;
- adaptation of new personnel in the workplace;
- personnel training and development;
- rapid personnel assessment;
- business communication management;
- personnel motivation and payment;
- labor organization;
- corporate culture management.

The main type of machine training that will be needed for recruiting tasks is precedent-based training, or inductive training, which is based on identifying common empirical patterns according to private data. Using CVs as input data, machine learning can be used both to find candidates: to narrow down the search or recognize common features of candidates, and to determine the most trustworthy candidates in the future, to determine whether the characteristics of the candidate and the team, the organization, to develop individual adaptation, correction and development programs.

Instead of forming an application and placing advertisements on job portals, interviewing potential candidates to determine whether the requirements of the vacancy correspond to their real skills, psychological, emotional and intellectual testing of candidates, the system loads a vacancy of any format. Then special algorithms process it (within a few minutes) and present several candidates, most suitable for the specified parameters of the vacancy. In addition, professional, psychological and social portraits of the candidate are formed. When using machine learning algorithms in search of potential employees, candidates are evaluated for their general intellectual abilities, leadership qualities, ability to take responsibility, as well as other personal qualities that an employee should have and professional skills. It should be noted that the number of analyzed personal qualities and psychological features of a candidate is not limited. Special algorithms allow identifying a large number of characteristics, including latent ones. A candidate is more than just the sum of knowledge, skills and abilities, and a multifaceted personality. In addition to standard parameters, machine learning algorithms allow to take into account data on personal contacts, social life, well-being, habits, hobbies, views, character and mood of the candidate. After the algorithm is developed, it is necessary to



work on errors to prevent false alarms. In this case, a false alarm is the program rejection of the application of potential good employees and acceptance of applications of potential bad employees.

CONCLUSION

An ideal employee in the digital economy is an "information worker" who shares a system of corporate values, is able to select the necessary information and create a new one out of many existing options. The main type of machine training that will be needed to solve the tasks of recruiting personnel, is training by precedents, or inductive training. Special algorithms of complex diagnostics of competences, psychological peculiarities, personality's values and their correspondence to the corporate culture, based on formal and informal information sources, reduce time and resources costs associated with the formation, development and use of human resources. Personnel management systems based on machine learning, being dynamic and adaptive, allow to track deviations of personnel competitiveness from the set parameters and offer activities in the field of professional development, career growth and development, correction of the emotional background of the personality and improvement of the psychological climate of the staff. The competitiveness, efficiency and sustainability of the organization as a whole are improved.

Thus, deepening and the expansion of digitalization will increase the competitiveness of the national economy in the world arena, provide conditions for a gradual transition to the level of innovation and knowledge economy, as well as improve the quality and standard of living.

REFERENCES

1. Abdullaeva M. *Future economies - for modern technologies. Published in the newspaper "Truth of the East". № 24 by 1.02.2020.*
2. Lyaskovskaya E.A. *Problems of preparation of qualitative labor resources at realization of the concept of sustainable and innovative development // Vestnik of Bashkir State Agrarian University. 2017. № 4 (44). P.p. 137-145.*
3. Polyanin A.V., Dokukina I.A. *Transformation of social and economic relations based on digitalization of business space // Labor and social relations. 2018. № 6. P. 16-27.*
4. Odegov Yu.G. *Personnel management: textbook and workshop for academic Bachelor's degree / 2nd edition. Moscow. Yurayt, 2018 .P.467.*
5. *Report on Digital Economy 2019. UN Conference on Trade and Development.*
6. Shoev D.A. *Important factors for improving education quality. // The problems of science. 2019. №12-2 (145). URL:*

<https://cyberleninka.ru/article/n/vazhnnye-factory-povysheniya-kachestva-obrazovaniya>

7. Yakubov V.G. *Development of ecotourism in Uzbekistan // Problems of Science. 2019. №11-2 (144). URL:*

<https://cyberleninka.ru/article/n/razvitie-ekoturizma-v-uzbekistane>



LINGUOCULTUROLOGY AS A LINGUISTIC DISCIPLINE

Dadakhonova Zulaykho Ma'murjohn qizi¹

*¹A Teacher of the Department of "Foreign Languages in Natural Sciences",
Faculty of Foreign Languages, Fergana State University, Fergana city, Republic of Uzbekistan*

Ergasheva Malika Khakimjonovna²

*²A Teacher of the Department of "Foreign Languages in Natural Sciences",
Faculty of Foreign Languages, Fergana State University, Fergana city, Republic of Uzbekistan*

Usmonova Shakhnoza Yoqubjon qizi³

*³A Teacher of the Department of "Foreign Languages in Natural Sciences",
Faculty of Foreign Languages, Fergana State University, Fergana city, Republic of Uzbekistan*

ABSTRACT

The article under discussion describes linguoculturology as a linguistic discipline. Linguistics becomes not only a science about language, but also a science about a person, his consciousness, language and culture. It is time to change the linguistic method of consciousness, i. e. a system of established stereotypes and views on the language and text, the ways in which they are taught in connection with a number of achievements in linguoculturology and cognitive linguistics, when a significant number of linguistic facts have been accumulated and explained. Along with cognitive linguistics, another trend emerged in the twentieth century, i. e. linguoculturology, the main issues of its study were the concept sphere of the culture and the language picture of the world.

KEYWORDS: *linguistics, linguoculturology, cognitive, culture, scientific environment, comparative, conceptual, essence, comparative analysis, discourse,*

DISCUSSION

The emergence of the interdisciplinary science of linguoculturology at the intersection of linguistics and culturology at the end of the XX century aroused a great interest in it among linguists. Already at the beginning of the next century, linguistic-cultural schools were being formed (for example, under the guidance of N.D. Arutyunova, V.V. Vorobiev, V.I. Karasik, V.V. Krasnykh, Yu. S. Stepanov, V.N. Teliya, etc.), and a certain conceptual and terminological apparatus of this linguistic direction was being formed taking into account various scientific concepts and methods of linguistic-cultural analysis.

As a rule, the emergence of new concepts and corresponding terms leads to some fundamental

disagreements and misunderstandings in the scientific environment. According to a remark by A. V. Lemov, "...scientists quite often cannot agree on the meaning of scientific words" [5]. However, linguoculturology as a humanitarian discipline is a rare exception in terms of defining its conceptual essence by the scientific community. A comparative analysis of the numerous definitions of linguoculturology that function in the scientific discourse has shown that almost all researchers are unanimous in their definition of this concept, which is based primarily on the dyad "language - culture". Only some of them can be compared.

Thus, for example, V.V. Vorobyov in his definition: "Linguoculturology is a complex scientific discipline of a synthesizing type that studies the



interrelation and interaction of culture and language in its functioning and reflects this process as an integral structure of units in the unity of linguistic and extra-linguistic content using systematic methods and oriented to modern priorities and cultural settings" [8], in addition to the mutual influence of culture and language, singles out other, rather significant indicators of linguoculturology: "complex scientific discipline of the synthesizing type". Thus, the place of linguoculturology in the system complex of humanitarian knowledge is clearly defined as a scientific discipline, which, accordingly, entails the presence of its own subject and object of study. No less important is the indication of the synthesis of scientific knowledge, which, in turn, is remarkable for the modern scientific paradigm, on the one hand, and on the other hand, requires the establishment of both common and differentiating features of the concept under study. In our opinion, the definition of linguoculturology proposed by V. Vorobyov is also capacious and substantial because it immediately orients researchers to a certain method of linguistic analysis - "system methods".

The definition of linguoculturology given by V.V. Krasnykh is also based on the general integrative family "culture - language"; but, in addition, the definition specifies other relevant features of the studied discipline: the national picture of the world, linguistic consciousness, national-mental features as fundamentally new objects of research: "linguoculturology is a discipline that studies the manifestation, reflection and fixation of culture in language and discourse. It is directly related to the study of the national picture of the world, language consciousness, and peculiarities of the mental-linguistic complex" [4].

In linguoculturology, there are relatively simple and complex oppositions that require a synergistic approach. This is the meaning-to-sense opposition. Meaning in synergetics is considered to be "the emergence of a new quality of the system, or, in other words, the self-negation of meaning" [2]. Therefore, the same linguistic unit, placed in different contexts (systems), can obtain very different meanings, which are generated, on the one hand, by contexts and, on the other hand, by the cultural semantics of these units themselves. Thus, phraseology is "души не чаять" in the meaning "to love very much, infinitely", it is like a standard of love, its limit. But from experience we know that infinite love makes a person vulnerable, dependent on what kind of soul the object of love has. It would seem that context can give both negative and positive assessment to the phraseology. But, as M.L. Kovshova rightly notes, this assessment does not depend on context, because the context itself "is conditioned by the cultural semantics of phraseology" [3]. An example of this also serve proverbs and

sayings with ambivalent meanings. In these cases, a space of new diffuse meanings is created that complicates the understanding of a language unit and creates a deeper vision of it, which creates a cultural space.

Each language, through the prism of which its native speaker absorbs culture and world understanding, has its own way of conceptualizing the world. Hence, we conclude that each language has to some extent a special picture of the world, and the linguistic personality is obliged to organize the content of the statement in accordance with this picture. This is the specific human perception of the world fixed in the language. V. Humboldt also wrote that each language outlines a circle around its people, beyond which it is possible to go only by mastering one more language.

The linguistic picture of the world of each nation reflects not only the modern mentality of the nation, but also includes folkloric, mythological, archetypical elements. It is here that those prescriptions, attitudes and values are stored, and guided by them, a person becomes a national-oriented personality. Let's consider it by example. Since 80% of information about the world comes through the eye, it is considered the most important of the organs, so the eyes were attributed a mysterious magical force. In Slavs, "bad" was considered to be a slanting eye. The belief in the evil eye was born when the world, according to the ancient ideas, was inhabited by spirits. But until now, when we feel bad, we say: "это сглазу", "кто-то сглазил", "недобрый глаз поглядел" ("it's an evil eye").

The phraseologies with the "eye" component have fixed and preserved to this day the ancient stereotypes of behavior. For example: "глаз не отвести" (so you had to communicate with your interlocutor); "для отвода глаз" (prevent you from perceiving the truth), etc. To deceive someone is to prevent him from adequately perceiving the world, i.e., first of all, to prevent him from looking, hence the phraseology "замазать глаза", "пускать пыль в глаза" ("to smear his eyes", "to let dust into his eyes").

Since ancient times, from the evil eye turned amulets, which were made of precious metals and stones and people made them in the shape of the eye, hence the phraseology of the type of "глаз-алмаз" ("eye - diamond") is the ability to see the important, the main); "беречь как глаз" ("take care as an eye") (very careful), "возьми глаза в руки" ("take the eyes in your hands") (be careful), "вооружённый глазом" ("armed with the eye" (the modern form of this phraseology "with the naked eye"). All of them are related to the protective function of the eye decoration [4].



CONCLUSION

Each particular language encapsulates a national, original system that defines the worldview of its speakers and forms their picture of the world. It is fair to say that not all linguists agree with this position. Thus, G.V. Kolshansky wrote that there is no reason to raise the question of special world membership through language [6]; the language only "changes thoughts" (L. Wittgenstein). We believe that our worldview is to a large extent in captivity of the linguistic picture of the world.

What will cognitive research give linguistics? It is difficult to assume concrete results, but new data on the content structure of human mentality, language consciousness, unconscious are already being viewed, because cognitive structures of the personality are in the depths of its psyche, in a sphere that unites myth, religion, art and other phenomena.

REFERENCES

1. *Dadakhonova, Z.M. Applying interactive methods in developing students' reading skills. EPRA International Journal of Multidisciplinary Research (IJMR) - Peer Reviewed Journal Volume: 6 | Issue: 5 | May 2020 || Journal DOI: 10.36713/epra2013 || ISI Value: 1.188. URL: https://eprajournals.com/jpanel/upload/733pm_4_5.EPRA%20JOURNALS%20-4428.pdf*
2. *Ergasheva M.K. Linguocultural study of national mental relations (on the example of respect category). EPRA International Journal of Research and Development (IJRD) Volume: 5 | Issue: 6 | June 2020. Journal DOI: 10.36713/epra2016 ISSN: 2455-7838(Online) URL: https://eprajournals.com/jpanel/upload/1122pm_73.EPRA%20JOURNALS-4712.pdf*
3. *Kovshova, M. L. Linguistic and cultural method in phraseology. Codes of culture. Moscow. 2012. P.p.34-37*
4. *Krasnykh, V.V. Some basic concepts of cultural linguistics // Russian language: Historical destinies and modernity. - Moscow: Publishing house of Moscow University. 2010. P.p.659-660.*
5. *Lemov A.V. Russian language and culture of speech. Moscow. 2004. P.p.67-78*
6. *Maslova, V. A, Pimenova, M. V. Codes of culture in the space of language. Series "Conceptual and lingual worlds." Issue 9. St. Petersburg. 2015. P.78*
7. *Prigogine, I. From the existing to the emerging. Moscow: The World. 1984. P.p.78-83*
8. *Vorobyev, V.V. Linguoculturology. Moscow. 2008 . P. 340.*



METHODOLOGY OF TEACHING INTERACTIVE LEARNING MODELS AT THE FACULTY OF MILITARY EDUCATION

Mamadjanov Alisher Muradovich¹

¹*A Senior Teacher of the Special Training Cycle, Military Education Faculty, Ferghana State University, Uzbekistan, Ferghana*

ABSTRACT

The article under discussion depicts methodology of teaching interactive learning models at the faculty of military education. The author of the article considers that teaching method of any academic discipline is a teaching science, which is a private theory of learning or didactics. There are many interactive forms and methods of learning - all of them encourage creative cognitive activities among young people. The use of the latest technologies increases visibility and facilitates the perception of material in teaching military studies, military law, military history, etc., which has a positive impact on the motivation of students, stimulates their cognitive activity and increases the efficiency of the educational process.

KEYWORDS: *methodology, interactive, motivation, students, increase, learning, material, qualified, teaching, educational, latest technologies, military.*

DISCUSSION

Teaching method of any academic discipline is a teaching science, which is a private theory of learning or didactics. The method of interactive learning is one of the sciences.

The issue of training highly qualified staff using the latest educational technologies and innovations, the lack of which has been particularly acute recently, is an important one for higher educational institutions, besides it is of interest to scientists, researchers and practitioners alike.

Higher education at the present stage is characterized by the ongoing improvement, rethinking and revision of the conceptual foundations of the educational process, increased requirements for the innovative potential of teachers, in particular, and the quality of the educational process as a whole. Undoubtedly, at present, the reserves for growth of efficiency and quality of training of students based on the use of "archaic" methods of influence on young students based on traditional means of education have been virtually exhausted [6].

Today, one of the main methodological innovations is interactive teaching methods. The term "interactive" has been included in our vocabulary

from the English language "interact". "Inter", which means "mutual", as well as "act" - to act. The thesis: "Interactive teaching methods are the basis of innovative pedagogical technologies" is becoming more and more relevant for the university. It is important to note that "an educational institution - according to I.P. Podlasiy - is innovative, if the educational process is based on the principle of environmental protection, the pedagogical system evolves in a humanistic direction, the organization of the educational process does not lead to a reset of students and teachers, the improved results of the educational process are achieved through the use of not previously disclosed and not used opportunities of the system, the productivity of the educational process n [3].

As you know, there are many definitions of interactive technology in the scientific literature, including the following:

- Interactive learning is a special form of organization of the educational process, the essence of which lies in the joint activity of students to master educational material, in the exchange of knowledge, ideas and ways of activity [4].



- Interactive learning is a dialogue learning process in which teacher and learner interact [5].
- Interactive learning is learning with well-organised feedback from subjects and objects of learning, with two-way exchange of information between them [7].
- Interactive learning technology is the kind of organization of the learning process in which it is impossible for the learner to not participate in a collective, complementary, participatory learning process [6].
- Interactive activities in lessons involve the organization and development of dialogue, where each participant becomes an interlocutor [1].
- Interactive technologies are a precondition for the functioning of a highly effective learning model, the main purpose of which is the active involvement of each of the learners in the educational and research processes [8].

However, it should be noted that all of the above definitions, in general, have coincidences in values. In our opinion, this is above all the case:

1. It is a new technology in the teaching of academic disciplines, in teaching young people certain skills and abilities, in gaining new knowledge, and it is a "fresh trickle" in the teaching process.

Although, we must admit that the term itself, different researchers have different nominations: "interactive technologies", "interactive methods", "interactive learning", "interactive actions", etc.

2. This technology (method, activity) is carried out mainly in a dialogue mode, i.e. participants in the interactive process are within the boundaries of "verbal interaction".

3. This technology is based on cooperation in different formats: "learner (student, pupil) - teacher", "learner - pupil", i.e. such a special "role distribution", when each of the participants has a certain status.

4. It is a specially (naturally or artificially) created learning process, a special organization of the learning activity, which differs from the traditional activity in that the learning activity is based on the acquisition of knowledge through joint contact in the process of performing learning tasks, as well as uniting the participants of the process to meet their own (personal) 'knowledge needs'.

5. Each interactive technology is an alternative to the "classic" technology. For it is an unconventional variant of obtaining and acquiring knowledge, which in its results is superior in quality to the traditional presentation of educational material. At the same time, it is a higher level of cognitive activity, an action from the unknown to the known, i.e. with each

acquisition of knowledge and experience, the participant (student) becomes "higher", getting (step by step, step by step) more and more new knowledge, increasing their achievements.

In this way, it is possible to derive a definition from all the combined definitions as follows: "Interactive technology is an innovation in teaching (or learning) that involves close contact between participants in the learning process, where the ideas, opinions of each of them are important for full cooperation in solving learning problems (problems, issues).

Indeed, the essence of interactive learning is a constant, active interaction of all participants in the learning process - students.

Kurt Levin made an interesting assumption in the mid-twentieth century that "it is easier to change individuals gathered in a group than to change any of them individually. This is the most important specificity of interactive learning: the learning process takes place in group collaboration" [1]. In my opinion, this statement by the researcher is also significant for students of the Department of Military Education, where the saying "one in the field is not a warrior" acquires real expression. For, in the opinion of specialists, the group form of training makes it possible to solve three main tasks simultaneously:

1) A specific cognitive task (educational, behavioural, etc.), which is related to the immediate learning situation;

2) Communication and development, which develops basic communication skills within and outside the group;

3) Social orientation, raising civic qualities necessary for adequate socialization of the future specialist in the community [1].

Interactive technologies are based on cooperation and mutual learning, which is why we think it is necessary to list them. The most commonly used forms of interactive technology are:

- Frontal form work on the following technologies: "Brainstorming (attack)", "Unfinished offer";

- Cooperative form of work (in pairs or in small groups): "Face-to-face", "Aquarium", etc.;

- Interactive game: "Role-playing game" (commander - soldier, soldier - soldier), "Business communication";

- Learning technologies in discussion: "Choose a position".

The attention of teachers of the Faculty of Military Education to interactive forms of training can be explained by the fact that specific techniques and methods are included in the fabric of the classes, which make the class more intense and interesting. I believe that it is particularly effective in the initial stages of training (first and second years of university studies). The advantage of these classes is that



students have the opportunity to express themselves and freely exchange ideas and thoughts.

What are the main ideas of interactive technologies? The following answers to this question are expected:

1) The technology is not intended for those academic disciplines in which truth has the property of multiplicity, i.e. there is no unambiguous answer to the cognitive question, there are several answers of varying degrees of truth.

2) With the use of interactive technologies, the emphasis is shifted not to the acquisition of ready-made knowledge, but to the search for that knowledge, to the creation of subjects of the educational process.

3) The use of interactive technologies of education results in both acquired knowledge and skills, as well as the ability to master the basics of professional activity.

4) Within the framework of technology, a model of a specific situation (real, life) is developed, which reflects the complex of knowledge and practical skills to be acquired by students. This model is a text called a "case" (case), which is studied by using lecture course materials and other various sources of information from different fields of knowledge (psychology, pedagogy, law, history, etc.) [10].

In this respect, it is important to note that the faculty reads the relevant disciplines: "Fundamentals of Military Law, Fundamentals of Military Psychology and Pedagogy, Civil Defence, Military History, etc., which may be included in the contents of the case study.

I also find it interesting to present educational material from a short excursion into the history of the topic (subject). For example: "According to a Russian researcher, the case method by A. M. Dolgorukov, this method was first applied at Harvard Law School in 1870; although its introduction into the process of studying at Harvard University began in 1920. The first sets of cases were published in 1925 in Harvard University reports, which spoke of the need to replace the verbal transmission of information with visual images and thus involve several channels of perception of information. [2]. This kind of presentation of programme material will be of particular interest to students, as the above passage refers to a case study method in a law school.

Another interesting interactive method of conducting military training sessions is case-study, i.e. problem-situation analysis in which decisions are made in the context of your future professional activity (in our case, military). The case-study requires a teacher to "teach" student youth [2].

Higher educational institutions are already actively introducing interactive technologies into teaching practice, and the Department of Military Education is no exception. However, this process is

not systematic and, as a result, the possibilities of interactive technologies are not fully and effectively used.

Thus, the use of the latest technologies increases visibility and facilitates the perception of material in teaching military studies, military law, military history, etc., which has a positive impact on the motivation of students, stimulates their cognitive activity and increases the efficiency of the educational process. [8].

Thus, there are many interactive forms and methods of learning - all of them encourage creative cognitive activities among young people. Interactive learning involves non-standard classes: games, seminars, contests, project classes, discussions, press conferences, etc. that have been changed, supplemented or modernised.

In my opinion, making the learning process cognitive, creative, interesting for students, as well as dynamic and modern is a task for every teacher. Here, interactive technologies come to their aid.

REFERENCES

1. Efimov P. P., Efimova I. O. *Interactive learning methods - the basis of innovative pedagogical technologies // Innovative pedagogical technologies: materials of the International scientific conference - Kazan: Book, 2014. P.p. 286 - 290.*
2. Dolgorukov A.M. *Case-study as a way to understand // Practical guide for tutor of Open Education system based on distance technologies. - Moscow: Center for Intensive Technologies in Education, 2002. P. 28 .*
3. Kobzar-Frolova M.N. *On the application of interactive technologies in teaching law disciplines to Masters // Financial Law. 2013. № 7. P.p. 21–23.*
4. Kashlev, S.S. *Technology of interactive teaching. - Moscow, 2005. P.7*
5. Bugrimov, I.V. *The Use of Interactive Technologies in Lessons. 2005. № 4.*
6. Yedeleva, E.I. *Interactive group work techniques// School psychologist. - 2004. № 15. P.8*
7. Korotaeva, E.V. *Teaching technologies in the cognitive activity of schoolchildren. - Moscow: September, 2003. P.56*
8. Shchurkova, N.E., Pityukov V.Yu. and others. *New Technologies of the Educational Process. - M., 1993. P.89*
9. *Development of Pedagogical Interaction and Creation of Conditions for Improving the Quality of Students' Education through the Technology of Interactive Learning: Seminar-Training Materials). - Ministry of Education, APO, 2006. P.p.78-86*
10. <http://www.polymedia.ru/podderzhka/spravochnik/interaktivnye-tehnologii-v-obrazovanii/> - *Interactive technologies in education.*



STUDY AND DESCRIPTION OF RUSSIAN AND UZBEK LINGUOCULTURES (CONTRASTIVE APPROACH)

Mamadjanova Gulmira Musinova¹

*¹a Teacher of the Department of Russian Philology, Faculty of Philology,
Fergana State University, Ferghana*

ABSTRACT

The article under discussion depicts study and description of Russian and Uzbek linguocultures (contrastive approach). The author of the article considers that within the boundaries of the newest linguistic anthropocentrism, the study of nationally separate linguistic and cultural units provides an opportunity to learn about the specificity and regularity of development and formation of human linguistic competence within the boundaries of a specific national and cultural community, a group of people. The study under discussion analyzes language implementations in two contact languages, Russian and Uzbek in particular, and searches for means of textual representation of important conceptual elements of national conceptual fields in the latest pedagogical direction.

KEY WORDS: *study, description, formation, development, cultural, linguistic, textual, competence, language, conceptual elements.*

DISCUSSION

At present, linguistics is deeply and comprehensively researching the conceptual, mental content of anthropocentrism in language. Such research, in our opinion, characterizes the culture and mentality of ethnic groups, their worldview, reflects the ethnic and linguistic picture of the world, which reflects their spiritual, moral and value attitudes. As it is known, within the boundaries of the newest linguistic anthropocentrism, the study of nationally separate linguistic and cultural units provides an opportunity to learn about the specificity and regularity of development and formation of human linguistic competence within the boundaries of a specific national and cultural community, a group of people.

Now it is impossible to study language without the modus of its existence - a human being. From the standpoint of anthropocentrism, a person cognizes the world through the awareness of himself, his theoretical and subject activities in it. Anthropocentric paradigm gives researchers an opportunity to link those moments of language's existence that were not previously sufficiently studied or remained outside the field of scientific research, which led to the expansion of scientific research in linguistics, expanding its horizons.

Man, language, culture is undoubtedly the central triad of linguoculturology.

We believe that the following V.V. Vorobyov's explanation can be an essential formulation of the general definition of the term "linguoculturology": "it is a complex scientific discipline of a synthesizing type that studies the interrelation and interaction of culture and language in its functioning and reflects this process as an integral structure of units in the unity of their linguistic and extra-linguistic content with the help of systematic methods and orientation towards modern priorities and cultural institutions" [5]. This definition is acceptable for our study. From the point of view of scientists, "eventually, the fusion of problems of linguistic knowledge in one interdisciplinary field can lead to the fact that linguocultural science can be talked about not only as a synthesizing, but also as a systematizing science" [6].

Undoubtedly, linguoculturology is represented by linguistic-cultural units, in particular, linguoculturology as one of the types of mental vocabulary.

A great contribution to the understanding of the concept of "linguoculturology" was made by V. Vorobyov, who published a weighty work "Linguoculturology. Theory and Methods". The term was introduced by V.Vorobyov. In



V.Vorobyov's understanding "linguoculturology is the totality of the form of the linguistic sign, its content and cultural meaning accompanying this sign". It dings linguistic culture to the deep meaning potentially present in the meaning as an element of its content [8].

As it is known, scientists of linguistic culture are distinguished as a special conceptual class. At the same time, it is important to note that linguoculture is a unit of linguocultural analysis. Words, word combinations, texts of national and cultural value may act in this capacity. Sources of linguoculture may be materials of national-cultural orientation (fiction, media texts, mass media, etc.). These sources, as the review and study of literature shows, are saturated with vocabulary of both cognitive and linguocultural character. In our study we used the list of linguistic and cultural units proposed by V.A.Maslova, general principles and criteria of material selection to which the scientist adhered. For "linguocultural units should represent an integral and sufficiently complete representation of the culture of the nation, a synchronous interaction of language and culture of the nation". At the same time, we believe that the system of linguoculture should be created and used in the conditions of contacts between two specific linguocultural communities (in our case: Russian and Uzbek).

In our study we relied on the list of linguistic and cultural units proposed by V.A.Maslova [4], on general principles and material selection criteria to which she adhered. Linguocultural units should represent a holistic and sufficiently complete representation of the culture of the people, the synchronous interaction of language and culture of the nation. In our opinion, the system of linguocultures is created and should be used in the conditions of contacts between two specific (Russian and Uzbek) linguistic and cultural communities. The Russian and Uzbek linguistic and cultural worlds are contrasting ethnic communities, but it should be noted that the linguistic and cultural communities have historically been in close contact for a long time.

Linguoculture "is a nationally labeled concept that represents a key mental and semantic education. The study is based on the Uzbek-language concept of 'dala-dasht' in a contrasting format (field), addressed in linguistic-cultural and psycholinguistic aspects, which involves studying the semantic characteristics of the 'dala-dasht' linguoculture that explains the national and cultural perceptions of the linguistic community. The psycholinguistic aspect, in turn, is related to the study of associative reactions of Russian-Uzbek and Uzbek-Russian bilingualism to the concept of 'dala-dasht', which is an element of ethnic and national language pictures of the world.

The concept of 'dala' in the Uzbek language is recognized as a linguoculture because it refers to the concept of 'field', the Uzbek word 'dasht' means 'steppe' as an embodiment of the national specific meaning of traditional and modern linguoculture of Uzbekistan.

We have studied the linguoculture 'dala-dasht' as an element of the national language picture of the world and as a means of access to the linguistic consciousness of bilingual speakers of Russian-Uzbek languages. The description of this linguoculture was borrowed from the Uzbek-Russian Dictionary. In the course of our work we have studied and described in a contrasting way the linguistic-cultural and psycholinguistic features of the 'dala-dasht' language culture as an element of the national culture of the Uzbek people. In this regard, we set the following objectives:

- 1) Systematization of various areas of linguaconceptology and approaches to defining the essence, typology and structural features of the national-labeled concept of linguoculture – 'dala-dasht' (field);
- 2) Analysis of the specific features of the national-labeled 'dala-dasht' (field) linguoculture in the national language picture of the world;
- 3) identification of linguistic and cultural peculiarities of functioning and ways of representing the 'dala-dasht' (field) linguoculture in the Uzbek ethnos and bilingual community on the basis of the Uzbek people's paremium fund and Uzbek and Russian works, as well as its frequency of use in the texts of ethnic and cultural topics;
- 4) Determination of the specifics of verbalization of the meaning of the national-labeled concept 'dala-dasht' (field) in the bilingual consciousness based on the method of observation and description;
- 5) Determining the specifics of understanding the dala-dasht (field) language culture on the basis of a sociological survey depending on the level of Russian language skills.

In the course of a direct associative experiment, the word 'dala-dasht' (field) was used as an incentive. The study is based on data from a psycholinguistic experiment conducted with 20 bilingual informants with Russian as their native language and 30 bilingual informants with Russian as their non-native language, taking into account the degree of Russian language proficiency of the members of each of these groups.

The analysis showed that the meaning of the linguoculture 'dala-dasht', taken separately by 'dala' - field coincides, and the concept as a whole 'dala-dasht', translated into Russian means 'field and steppe' do not coincide in their basic meaning, as each word is represented as a separate independent word: 'dala' - 1) field; 2) country estate, dacha; as well as a separate linguoculture 'dasht' is understood



as steppe, plain, field. If these two words are written with a hyphen, the following can be observed: 'dala-dasht' - boundless fields and steppes. They express different semantic shades of linguistic culture (identified in the survey material).

It is also important to note that when reviewing the materials of the periodic press, the 'dala' linguoculture is mainly used to describe field work, in particular, when it refers to cotton fields - 'пахта далалари', respectively, in Russian - wheat field, corn field (cultivation of agricultural crop), etc.

Often a saying is used in periodicals, as review has shown: 'Onaning ko'ngli bolada, bolaning ko'ngli dalada' - literally means: "The mother thinks about her child, and the child thinks about the field" (i.e. games, etc.). - in a figurative sense. Of course, here the linguoculture "field" is given in the figurative meaning, which you will not find in other languages.

It is important to note that the 'dala-dasht' language culture is synonymous with the 'dala-tosh', 'dala-tuz' language culture. 'Dasht' linguocultures (dasht-suhro - a desert plain), expresses the concept of "steppe, plain, field" in combination with "dasht-biyobon", i.e. "fields and deserts". The saying: "Men bogdan kelsam, sen - dashtdan" literally means: "If I come from the garden and you come from the steppe". In Russian, this saying corresponds to the Russian proverb: "One speaks about Phoma, the other speaks about Yeryoma" or "I speak about Ivan and you speak about Balvan". As it can be seen from the examples, each language uses background, mental vocabulary specific to its people, in this case the linguoculture 'dala-dasht' - a concept which meaning is characteristic of the Uzbek people.

Of course, both words and linguistic cultures include language segments, such as sign and meanings. But, as is known, unlike words of linguistic culture, both include segments of not only language, but also extra-linguistic cultural meaning, therefore, for example, linguistic culture 'person' - translated into Uzbek as 'inson' and, as 'odam', which in Russian and Uzbek language include segments of not only language, but also cultural meaning, both Russian and Uzbek. At the same time 'odam' and 'inson' are translated into Russian as 'person' and 'personality' in the Uzbek language linguistic culture. The word 'odam' ('person') is plural in both Uzbek and Russian and is used in the following meanings:

Odamlarga kushilmok (or aralashmok) - to communicate with people; Odamlardan o'zini olib yurmok - to be alien to people; Odamning qadr-qiyamati - human dignity; Odam ovozi - human voice; Biror odam - someone; someone; Khar bir odam - everyone; Duch kelgan odam - first person encountered; Odam bo'lmoq or odamga aylanmoq - 1) to become a full-fledged person; 2) in the

figurative sense - to recover, to get younger; 3) in the figurative sense - to correct, to become a good, real person (about a person, animal, thing); Odam bo'lmaydi - not to correct, he will remain that way; Odam qilmok - 1) to make a person, to bring him into people; 2) in the figurative sense - to raise, educate; 3) in the figurative sense - to correct, to make good, real (about a person, animal, thing); Odam bolasi or Odam farzandi - 1) human child, human (in general), for example: Tavba, khursandchilik odam bolasi nimalar qilmaydi-ya! (from the work of M. Ismoilii "Farg'ona") - Oh my God, what joy will not do to a man! Khaqiqiy inson, yahshi fazilatli chin inson. - A true man, a true man with good qualities. Proverb: Otang bolashi bulma, ode bolashi bulma. - literally: Do not be the son of your father, but be the son of a man - be a real man; 2) a man, a face, a soul (as a unit of account) - ode to the god - for every man, for every soul; 3) a man - a servant or supporter, an adherent, dependent on the higher position of a person. - Qozi odamlari bilan chiqib ketgandan so'ng, Vali aka minnatdorchilik bilan o'glining elkasiga qoqdi - After the kazi and his men left, Vali aka gratefully patted his son on the shoulder; "...madomiki men bilan birgasiz, mening odamimsiz, har bir ishni men bilan bahamjihat qiling (Oybek 'Sacred Blood') - ...as long as you are with me, you are my man, do every job by coordinating with me. Odamgarchilik - 1) humanity - Uning odamgarchiligi yoq - he has no humanity; 2) human face - odamdan chiqqan, odamgarchiligi yy'qotgan - lost human face. Odamjon is a caring guardian. Odamzod - 1) human - Odamning oyogi etmagan joylar - places where a human leg has not gone; 2) human race, humanity. Odamiy - 1) human; 2) human being. Odamiyat - love of humanity. Odamlarcha - in human terms, as a human being, as human beings. Odamparvar - human love. Odamsevmas - hates people, misanthrope. Odamsimon - humanoid, human-like (about monkeys) [1].

There are different word combinations and phraseologies with this linguoculture. These linguocultures have similar meanings in two contact languages. The following expressions can also be taken as an example for comparison: 1) A human being is a living being who has thought, speech and the ability to work. - "Inson - bu tirik mavjudod bo'lib, u ong, nutq va mekhnat qilish layaqqotlidir". 2) Human being as a living being (human being, human qualities). - Inson tirik mavjudod kabi ... (inson, insoniy phasilatlar). Bud qanday odam? - What kind of person is he/she? - The primitive man is ibtidoi odam. 2) It is a person as the embodiment of high moral and intellectual qualities. In the second sentence of the linguoculture, "a person" can be used



in the meaning of pronouns: it is him, someone 3) A person is a subordinate, boss, assistant, minister, etc. - Odam - bu yordamchi, ishchi.

All the above meanings of the linguocultures "man - odam, inson" in comparable languages (Russian and Uzbek) indicate only the coincidence of the lexical concept as a whole. However, there are also a few examples of mismatched meanings. So, the cultural components inherent in the linguistic cultures of the Russian and Uzbek languages, "man" and "odam (inson)", have both similar meanings and different meanings, due to the difference and mismatch between the Russian and Uzbek national cultures. Some meanings of these two linguocultures are caused in the minds of Russians and Uzbeks in different ways, because these peoples have different mentality, different views, world outlook, and thinking.

It is known that throughout the history of the development of linguistics, vocabulary (everyday life) has been under the scrutiny of linguist scholars. It is 'in the semantics of specific subject nouns that the closest connection between the lexical meaning of a word and the specific properties of reality is observed. Take, for example, for comparison, the linguistic culture of 'clothing' – 'kiyim, narsa'. As a rule, the names of clothing items in both Russian, Uzbek and English are based on two fundamental characteristics: 1) function and 2) appearance features. As regards the appearance of the items, material, form, colour, etc. can be used as motivational features. Generalization of motivational features makes it possible to formulate the nomination principle, which subsequently serves as a basis for newly formed names. Often, transportable meanings initially emerge as trails, figurative expressions and are used to enhance speech expression. However, as the language develops, they may well become facts. From the perspective of this study, the concepts of "metaphor" and "metonymy" are considered, since it is these trails that are used in the formation of the linguistic culture of the thematic group 'clothing' (kiyim, narsa) [2].

The study of the linguistic culture of 'dress' revealed both similarities and differences in the nominal systems of the Russian, Uzbek and English languages. The data obtained allow us to state that the specifics of the cultural labelled names of 'clothes' are such that the overwhelming majority of the linguistic cultures studied are based on either metaphorical or metonymic transference of meaning. In addition to traditional methods, the Uzbek language has a number of nominative models that are not typical for word production in the Russian language.

CONCLUSION

In our work we present the results of structural-semantic and linguistic-cultural description by linguocultures included in the thematic group 'people', 'field', 'clothes' in Uzbek and Russian.

Thus, this study analyzes language implementations in two contact languages, Russian and Uzbek in particular, and searches for means of textual representation of important conceptual elements of national conceptual fields in the latest pedagogical direction.

REFERENCES

1. *I.Uzbek-Russian Dictionary// Edited by S.F.Akobirov and G.N.Mikhailov. - Tashkent, 1998. P. 727.*
2. *Azizov A.A. Russian-Uzbek Brief Dictionary. - Tashkent: O'qituvchi, 1988. – P. 515.*
3. *Ozhegov S.I. Dictionary of Russian Language. - Moscow: Russian Language, 1987. P.796.*
4. *Maslova V.M. Introduction to linguoculturology. - Moscow: Legacy, 1997. –P.207*
5. *Vorobiev V.V. Linguoculturology. Theory and methods. - Moscow: Science, 1997. P.45*
6. *Thorik V.I., Fanyan N.Y. Linguoculturology and intercultural communication. - M., 2005. P.78*
7. *Vezhbtskaya A. Understanding Cultures through Keywords. M., 2001. P.88*
8. *Vorobiev V.V. A Cultural Paradigm of the Russian Language. Theory of Language and Culture Description in Interaction. - Moscow: Institute of Russian Language, 1994. P.65*



A STUDY ON CUSTOMER'S SATISFACTION ON SOLAR ENERGY PRODUCTS WITH SPECIAL REFERENCE TO COIMBATORE CITY

Indrajith.P

*Student of III B.Com.(PA), Department of Commerce with Professional Accounting,
Dr. N. G. P Arts and Science College, Coimbatore.*

Dr. K. Vanaja

*Head of the Department, Department of Commerce with Professional Accounting,
Dr. N. G. P Arts and Science College, Coimbatore.*

ABSTRACT

Humanity faces an exclusive and extensive challenge in energy/heat. It has played a pioneering role, but there is a narrowing gap between demand and supply of energy. At present we depended the non-renewable source of energy. These are all having the so many carbon by-products and pollute the environment. So the man has evolving to and out the alternatives source of clean energy. In such way one of the alternative renewable energy is solar energy. The study is descriptive in nature both primary and secondary data to be considered for this analysis. 100 samples are randomly selected in the area of north zone of Coimbatore and analysed for the study. Three objectives are framed and required tools to be applied for this study. Through this study customers awareness and attitude towards solar water heater have been analysed and provide the suitable suggestions to improve the solar energy utilization in households..

KEYWORDS- *Alternative source, Non-renewable, Solar energy, Utilisation.*

INTRODUCTION

Customer satisfaction is closely linked to quality. In recent years many companies have adopted total quality management (TQM)programmers, designed to constantly improve the quality of their products, services and marketing process. Quality has a direct impact on product performance and hence on customer satisfaction.Satisfaction is a person feeling of pleasure or disappointment resulting from comparing a product perceived performance in motion to his or her expectation.The extent to which a product perceived performance tells short of expectation, the buyer is dissatisfied. If performance matchers or exceeds expectations, the buyer is satisfied or delighted.Outstanding marketing companies go out of their way to keep their customer satisfied. Satisfied customer make repeat purchase, and they tell others

about their good experiences. Smart companies aim to delight customer by promising only what they can deliver, then delivering more than they promise.Customer is central point and all the marketing activities revolve around him. manufactures products what the customer want. Customer purchase an articles as a consequence of certain mental and economic forces creating designers or wants which they understand can be satisfied by the articles offered for purchase thus producers should identify the motives which prompt them to purchase so that he can offer a couple of articles satisfying their needs. Thus it is buying motive that prompts the purchaser such buying motives maybe fear.



STATEMENT OF THE PROBLEM

This study focuses on the customer satisfaction towards solar energy products. In the market a customer will buy the products when that product fulfil their wants. In today world usage of electricity is high and its price also high, so customers are go for the solar products as the substitute for the electronic products. Solar energy products will fulfil the place of the electronic products. But customers are expecting more from the solar energy product companies. Present survey is conducted to find out the level of customer satisfaction on solar energy products.

SCOPE OF THE STUDY

- The main scope of the study is to analysis the customer satisfaction towards solar energy products.
- This study helps to identify the factors that influence the consumer to buy the solar energy products.
- This study helps to understand the customer needs and wants.

OBJECTIVES OF THE STUDY

- To measure the overall satisfaction towards solar energy products in Coimbatore city.
- To study the factor influencing the customer to purchase solar energy products Coimbatore city.
- To provide the valuable suggestion to the company based on customer feedback.

TOOLS FOR ANALYSIS

The primary data were coded, classified, tabulated and analysed. The statistical tools used for analysis of the study are:

- Simple percentage Analysis
- Likert scale analysis

LIMITATION OF THE STUDY

- The research study on solar energy products is limited to Coimbatore city only.
- This study is limited to 120 respondents.
- The customers may uncertain to provide necessary information.

REVIEW OF LITERATURE

Adam Faiers(2006), This study says that the early adopters are currently adopting, the system, whereas, unless the attributes of solar power change, or external factors increase the relative advantage, the early majority are unlikely to adopt. Early majority may influences how marketing messages should be directed and delivered at a time when solar power becomes attractive to the early majority

Sai Manoj Rompicherla(2013), In the capital city of India, Delhi, citizens can face hours without electricity, but they are lucky. The basic weakness of the electricity supply industry is non availability of tariff. The industries are more depend on self generation of electricity. the use of solar energy for the production of electricity reduces the price/unit. The only problem is high installation charges. In future solar energy is the solution for the electricity insufficiency.

Dr.M. Venkarraman and Ms.U. Sheeba(2014), "Customer is the king of the market. It is also suitable for solar devices. Customers attitude towards solar devices is definitely changing due to many valid reasons and also there been a significant increase in the awareness and benefits of using solar energy devices over electrical devices. In the fastmoving world consumption of energy is abundant thus the customers will move on to othersources like solar energy for their consumption.

DATA ANALYSIS AND INTERPRETATION

In this chapter the analysis and interpretation of "A study on customer's satisfaction on solar energy products with special reference to coimbatore city" is presented based on the opinion of samples of 120 respondents selected from Coimbatore city through a questionnaire containing 20 questions. These were analysed through two different tools and they are as follows,

Simple Percentage analysis

Likert scale Analysis

SIMPLE PERCENTAGE ANALYSIS:

Simple percentage analysis is the method to represent raw streams of data as a percentage for better understanding of collected data. Percentage analysis is applied to create a contingency table from the frequency distribution and represent the collected data for better understanding.

**FORMULA:**

$$\text{Percentage} = \frac{\text{Number of respondents}}{\text{Total no. of respondents}} \times 100$$

TABLE 1
TABLE SHOWING THE GENDER OF THE RESPONDENTS

Gender	No .of Respondents	Percentage
Male	80	60.6%
Female	52	39.6%
Total	132	100

*(Source: Primary data)***INTERPRETATION**

It shows that there are 60.6% of male and 39.6% female respondents in the study

INFERENCE

Majority (60.6) of the respondents belong to the gender of male

TABLE 2
TABLE SHOWING THE EDUCATIONAL QUALIFICATION OF THE RESPONDENTS

Qualification	No of Respondents	Percentage
SSLC	15	11.4%
HSC	40	32.6%
Under Graduate	50	37.9%
Post Graduate	15	15.2%
Others	12	11.4%
Total	132	100

*(Source: Primary data)***INTERPRETATION**

It shows that the above mentioned table 4.1.3 states the qualification of the respondents among which qualification of the respondents SSC or Below is 10.8%, HSC is 32.5%, Under Graduate is 27.5%, Post Graduate is 17.5%, Diploma is 11.7%

INFERENCE

Majority (32.5%) of the respondent belong to the category of qualification with HSC

TABLE 3
TABLE SHOWING THE OCCUPATIONAL STATUS OF THE RESPONDENTS

OCCUPATION	NO OF THE RESPONDENTS	PERCENTAGE (%)
SELF EMPLOYED	22	17.6
SALARIED	49	39.2
OTHERS	54	43.2
TOTAL	125	100

INTERPRETATION

From the above table it is clear that out of 125 respondents 17.6% of the respondents are self

employed, 39.2% of the respondents are salaried, 43.2% are others.

Majority, 43.2% of the respondents are others.

**LIKERT SCALE ANALYSIS**

Likert scales are the most broadly used method for scaling responses in research studies. Research questions that ask you to indicate your level

of agreement, from strongly agree or highly satisfied to strongly disagree or highly dissatisfied, use the likert scale. In Likert scale method, a person's attitude is measured by combining (additional or averaging) their responses across all items.

FORMULA

$$\text{Likert scale} = \frac{\sum fx}{\text{Total number of respondents}}$$

Where,

F = Number of respondents

X = Likert scale value

$\sum fx$ = Total score

Mid value,

Mid-value indicates the middle most value of the Likert scale.

TABLE 4
TABLE SHOWING PRICE SATIAFACTION LEVEL OF SOLAR ENERGY PRODUCT USERS

Satisfied Level	No of Respondents	Likert scale value	Total value
Highly satisfaction	42	5	210
Satisfied	51	4	204
Neutral	21	3	63
Dissatisfied	10	2	20
Highly dissatisfied	8	1	8
Total	132		505

(Sources data : primary data)

INTERPRETATION

$$\begin{aligned} \text{LIKERT} &= \frac{\sum (fx)}{\text{Total number of respondents}} \\ &= 505 / 132 \\ &= 3.82 \end{aligned}$$

INFERENCE

Likert scale value is 3.82 which is greater than 3. So the respondents are satisfied.

FINDINGS, SUGGESTIONS AND CONCLUSION**FINDINGS****SIMPLE PERCENTAGE ANALYSIS**

- Majority (60.6) of the respondents belong to the gender of male

- Majority (62.1%) of respondents belong to the age group of Less than 20 years
- Majority (32.5%) of the respondent belong to the category of qualification with HSC
- Majority (77.3%) of the respondents are un married
- Majority (61.1%) of the respondents are students
- Majority (68.18%) of the respondents belong to the category of monthly income with Less than 200000.
- Majority (38.63%) of the respondents need for the Solar energy products in satisfaction.
- Majority (40.2%) of the respondent purchasing factor is price



- Majority (31.81%) of the respondents previously used models of 10kw, 25kw
- Majority (51.51%) of the respondent expected quality of solar energy products.
- Majority (35.60%) of the respondents knows about TV advertisements.
- Majority (31.06%) of the respondents buying the solar energy products.
- Majority (39.39%) of the respondents to affordable to the opinion concerning to the solar energy products.
- Majority (37.87%) of the respondent of currently using solar lights.

LIKERT SCALE ANALYSIS

- Likert scale value is 3.82 which is greater than 3. So the respondents are satisfied.

SUGGESTIONS

- Solar energy products at low cost.
- Need to improve quality and durability of products .
- Need more innovative products.

CONCLUSION

Solar power is an immense source of directly usable energy and ultimately creates others energy resources biomass, wind, hydropower and wave energy. the energy of lights shifts electrons in some semiconducting materials. This photovoltaic effect is capable of large scale electricity generation.

REFERENCE

1. Adam faiers, "A Study on consumer attitudes towards domestic solar power systems" Vol-34 Issue 14 sep 2006, pages 177-1806.
2. Sai Manoj Rompicherla. " A study on solar energy:the future" Ijett,Vol-4,Issue-6.June-2013,ISSN-2231-5381.
3. Dr.M.Venkatraman and U. Sheeba. "A study on customer attitude towards solar energy devices" Irjbm,Vol-5 May 2014 ISSN:2322-083.



A STUDY ON CUSTOMER SATISFACTION AND PREFERENCE TOWARDS ZOOM CAR

Dr. D. Sivasakthi

*Assistant Professor, Department of Commerce with Professional Accounting,
Dr. N.G.P Arts and Science College, Coimbatore*

Sridhar. P

*Student of III B.Com(PA), Department of Commerce with Professional Accounting,
Dr. N.G.P Arts and Science College, Coimbatore*

ABSTRACT

Customer satisfaction is a business term, is a measure of how products and services supplied by a company meet or surpass customer expectation. It is seen as a key performance indicator within business and part of the four perspective of balanced scorecard. In a competitive market place were businesses compete for customers, customer satisfaction is seen as a key differentiator and increasingly has become a key element of business strategy customer satisfaction drives successful private sector business. High performing businesses have developed principles and strategies for achieving customer satisfaction.

KEYWORDS: Car, Booking, Satisfaction, Preference, Transportation.

INTRODUCTION

Customers on a regular basis to increase customer satisfaction. In these interactions and communications it is required to learn and determine all individual customer needs and respond accordingly. Even if the products are identical in competing markets, satisfaction provides high retention rates. For example, shoppers and retailers are engaged with frequent shopping and credit cards to gain customer satisfaction, many high end retailers also provide membership cards and discount benefits on those cards so that the customer remain loyal to them.

SCOPE OF THE STUDY

The scope is related to the study about the customer satisfaction and preference to Zoom cars. This study would enable to create a new idea about the Zoom cars with a view to offering its customers a better service. This study is made among the people who are residing in the coimbatore city.

STATEMENT OF THE PROBLEM

In the recent times the number of rental car services are increasing day by day in India. The companies producing it make aggressive advertising and promotional efforts through various ways. These companies resort to

offers and discounts, function addiction and focus advertising and promotional campaigns . There are numerous number of manufacturers in market who produce similar method of rental cars with desired quality for reasonable price. All the manufacturers of rental car companies try to satisfy the need of customers.

OBJECTIVES OF THE STUDY

- To identify the performance of the respondents about Zoomcar
- To Examine the Zoomcar's influence on respondents upon using it
- To study about the respondent's view of what they like more about Zoom cars
- To identify the problems faced while using zoom cars.

AREA OF STUDY

This study is conducted within the Coimbatore city.

TOOLS FOR ANALYSIS

- Simple percentage analysis
- Likert Scale Analysis

**REVIEW OF LITERATURE**

D.Shanthi 2018, in the study titled, " A study on factors influencing the consumers in selection of cab services", had stated that there was witnessed a sudden growth in travel with the advent of the radio cabs services providers. To assess the impact of each of the five parameters on the overall customer satisfaction derived from the online cab services. Data collection was carried out using an adaptation of the structured questionnaire in primary data. This study takes into consideration just the surface of the iceberg for the huge potential for online cab services in India. The Author concluded that responsiveness or the willingness to help customers and provide prompt service place a vital role in overall customer satisfaction.

Ashima Gupta(2018), In the titled, 'Consumer perception towards app based taxi sector'. The author describes that, the transportation industry has undergone drastic changes in recent years with the introduction of application-based taxi and car service hailing systems. The objective of the research is to assess the marketing potential of app based passenger transportation system and identify the key factors which influence the customer satisfaction in app based taxi segment. The research is done by collecting primary data from the respondents through random sampling methodology. Through this study it is found that apart from price, people have prioritized safety as an important

factor. In conclusion, the business is booming in a huge way in India with versatile private operators both national and international investing tremendous money in setting up the call centers, acquiring fleets of new cars, and incorporating latest technologies in their vehicles.

D.Shanthi(2018), The Author describes, Among various modes of transportation the cabs have become important mode of transportation in metropolitan and urban cities in India. The objectives of the research is to ascertain the role of innovativeness of the consumers in the selection of cab services. The research is done by collecting primary data. Through this study

46 percent of the respondents were getting 10000-20000 income level .In conclusion, There is stringent competition in the organized cab services industry therefore organization need to motivate consumer through coupons.

DATA ANALYSIS AND INTERPRETATION**Simple Percentage Analysis**

The percentage analysis is usually employed in any study relating to social science to assess the distribution of respondents under each classification. The distributions of the respondents are expressed in percentage, to facilitate comparison.

Formula

$$\text{Percentage} = \frac{\text{Number of respondents}}{\text{Total number of respondents}} \times 100$$

TABLE SHOWING GENDER OF THE RESPONDENTS

S. No	Gender	No.of Respondents	Percentage
1	Male	48	41.7
2	Female	76	58.3
	Total	120	100.0

(Source primary data)

INTERPRETATION

The above table shows that the customer surveyed for vivo mobiles 41.7% are male and 58.3% are female.

Majority (58.3%) of the respondents are female.

**TABLE SHOWING AGE OF THE RESPONDENTS**

S. No	Age (Years)	No. of respondents	Percentage
1	Below 15	2	1.67
2	16 to 25	108	90.00
3	26 to 35	9	7.50
4	36 and above	1	0.83
	Total	120	100.0

*(Source: Primary data)***INTERPRETATION**

The above table shows that 1.67% of the respondents are below 15 years, 90% of the respondents are between 16 to 25 years, 7.50% of the respondents are between 26 to 35 years, and 0.83% of the respondents are 36 years and above.

Majority (90.00%) of the respondents are 16-25 years.

LIKERT SCALE ANALYSIS

A Likert scale is a psychometric scale commonly involved in research that employs

questionnaires. It is the most widely used approach to scaling responses in survey research, such that the term is often used interchangeably with the rating scale.

FORMULA

LIKERT SCALE=SUM OF (FX)/NUMBER OF RESPONDENTS
 $f = \text{NO. OF RESPONDENTS}$
 $x = \text{LIKERT SCALE VALUE (fx) = TOTAL SCORE}$

MID VALUE

Mid-Value indicates the middle most value of the Likert scale

HIGHLY SATISFACTION REGARDING VIEWS OF THE ZOOM CAR

S.NO.	FACTORS	NO. OF RESPONDENTS	LIKERT SCALE VALUE	TOTAL SCALE
1	Highly satisfied	1	5	4
2	Satisfied	2	4	57
3	Neutral	19	3	160
4	Highly satisfied	80	2	17
5	Dissatisfied	17	1	103
	Total	120		341

(Source: Primary data)

$$\begin{aligned} \text{Likert Scale} &= \sum(fx) / \text{Total number of respondents} \\ &= 341/120 \\ &= 2.841 \end{aligned}$$

INTERPRETATION

As a result of Likert Scale analysis, it was determined that the consumers are satisfied with the views of Zoom car.

Likert Scale value 2.841 is greater than mid value (2.5). So, the consumers are Satisfied with views of Zoom car.

**SATISFACTION REGARDING VIEWS OF THE ZOOM CAR**

S.NO.	FACTORS	NO. OF. RESPONDENTS	LIKERT SCALE VALUE	TOTAL SCALE
1	Highly satisfied	3	5	15
2	Satisfied	2	4	8
3	Neutral	11	3	33
4	Highly satisfied	83	2	166
5	Dissatisfied	21	1	21
	Total	120		243

$$\begin{aligned} \text{Likert Scale} &= \sum(fx) / \text{Total number of respondents} \\ &= 243/120 \\ &= 2.025 \end{aligned}$$

INTERPRETATION

As a result of Likert Scale analysis, it was determined that the consumers are satisfied with the views of Zoom car.

Likert Scale value 2.025 is greater than mid value (2.5). So, the consumers are Satisfied with views of Zoom car.

FINDINGS

- Majority (58.3%) of the respondents are female.
- Majority (90.00%) of the respondents are 16-25 years.
- Majority (75.00%) of the respondents belong to Under Graduates.
- Most (48.33%) of the respondents are Students.
- Majority (54.17%) of the respondents have a Monthly Income below Rs 20,000.
- Majority (90.00%) of the respondents are unmarried.
- Most (40.00%) of the respondents are influenced by Advertisement.
- Majority (42.50%) of the respondents are motivated by Social media.
- Majority (50.83%) of the respondents are preferring Zoom cars because of Better Service.
- Majority (76.7%) of the respondents are accepted vivo mobiles price is affordable.
- Most (40.83%) of the respondents are to know the vivo phones through social media.
- Majority (88.37%) of the respondents are accepted vivo mobiles quality match its price.
- Majority (75%) of the respondents are satisfied to Vivo Company making continues mobile phones.
- Majority (52.5%) of the respondents

recommended the vivo mobiles to their friends.

- Most (43.33%) of the respondents are rating comfort of Vivo mobile is good.
- Majority (53.3%) of the respondents are influenced in the Vivo mobiles are well set up compare to others.
- Majority (74.7%) of the respondents are satisfied the customer service of Vivo mobiles.
- Majority (79.7%) of the respondents are satisfied the of Vivo mobiles.

FINDINGS OF LIKERT SCALE

- Likert Scale value 2.841 is greater than mid value (2.5). So, the consumers are Satisfied with views of Zoom car.
- Likert Scale value 2.025 is greater than mid value (2.5). So, the consumers are Satisfied with views of Zoom car.
- Likert Scale value 2.841 is greater than mid value (2.5). So, the consumers are Satisfied with views of Zoom car.
- Likert Scale value 2.241 is greater than mid value (2.5). So, the consumers are Satisfied with views of Zoom car.
- Likert Scale value 2.141 is greater than mid value (2.5). So, the consumers are Satisfied with views of Zoom car.

SUGGESTIONS

- This study suggested that Zoom cars could improve to produce variety of cars.
- Most of the respondents have faced problems in delay of refunding the amount so it can be reduced.



- Most of the respondents came to know about the Zoom car only through social media. So the advertising can be improved.
- This study suggest that the convenience for people can be mad

CONCLUSION

This study concluded that in this modern business economy it is very important to analyse the customer satisfaction about Zoom cars the result shows that the majority of customers are been satisfied with the service provided by zoom cars but also there is drawback on the ways of inconvenience and delay of refunding charges. If these problems are been resolved the customers for Zoom cars will get increased. Hence it also develop the customer satisfaction based on Zoom.

REFERENCE

1. **D.Shanthi 2018**, in the study titled, "**A study on factors influencing the consumers in selection of cab services**", had stated that there was witnessed a sudden growth in travel with the advent of the radio cabs services providers.
2. **Ashima Gupta(2018)**, In the titled, "**Consumer perception towards app based taxi sector**". T he author describes that, the transportation industry has undergone drastic changes in recent years with the introduction of application-based taxi and car service hailing systems.
3. **D.Shanthi(2018)**,The Author describes, Among various modes of transportation the cabs have become important mode of transportation in metropolitan and urban cities in India. The objectives of the research is to ascertain the role of innovativeness of the consumers in the selection of cab service.



A STUDY ON CUSTOMER SATISFACTION ON ICICI BANK WITH SPECIAL REFERENCE TO COIMBATORE CITY

Mr.P.Kanagaraj

*Assistant Professor, Department of Commerce with Professional Accounting
Dr. N. G. P Arts and Science College, Coimbatore*

Hariharan .S

*Student of III B.Com (PA), Department of Commerce with Professional Accounting
Dr. N. G. P Arts and Science College, Coimbatore*

ABSTRACT

Customer Satisfaction in a banking sector is the most imperative criteria and resources for assessing and fulfilling clients and in this way builds the customer loyalty and normal standard for dependability of clients . Among the service quality determinants Tangibility, Responsiveness, Reliability, Assurance, Empathy have constantly assumed a crucial part, in this paper an endeavor is made to discover the effects of Service Quality measurements on Customer Satisfaction for the investigation it is discover that substantial quality dependability, responsiveness and affirmation significantly affect Customer Satisfaction. At last, it is discovered that there is no noteworthiness distinction out in public and private sector banks with identified with SERVQAUL measurements.

KEYWORDS: *Assurance, Customers satisfaction, Tangibility, Reliability and Responsiveness.*

INTRODUCTION

Section 5 (b) of the banking regulation act 1949 defines "Banking" as "Accepting for the purpose of lending and investment, deposits of money from the public repayable on demand or otherwise and withdraw able by cheque, draft, order or otherwise". A Bank is an organisation which lends money to the borrowers for a purposeful task, and provides a facility to deposit and withdraw money when needed and charge for it. Customer Satisfaction refers to how satisfied customers are with the product or services they receive from a particular agency. ICICI Bank commenced operations as a scheduled commercial bank in January, 1995. ICICI Bank began operations in 1995 with a simple mission to be a "World class Indian Bank". In 1994 ICICI Bank was incorporated, with its registered office in Mumbai, India. Its first corporate office and a full service branch at Sandoz House, Worli were inaugurated by the union finance minister, Manmohan Singh. It realised that only a

single minded focus on product quality and service excellence would help us get there. Today the Bank is proud to say that it is well on its way towards that goal.

STATEMENT OF THE PROBLEM

To overcome the problems in ICICI netbanking transactions and to improve customer relationship management. Mainly to avoid server problems in ICICI mobile application. To guide ICICI Representatives, to clearly mention the interest rates to the customers before providing home loans.

To overcome weakness, positive correlation between customer satisfaction and customer retention towards ICICI Bank. There is need for an extensive study on the rural customer's perceptions on the service quality in banking service offered in rural areas.

SCOPE OF THE STUDY

Consumers all over the world have become more



quality conscious; hence there has been an increased customer demand for higher quality service. Service operations worldwide are affected by this new wave of quality awareness and emphasis. Therefore service-based companies like the banks are compelled to provide excellent services to their customers in order to have sustainable competitive advantage, especially in the current trend. Customer satisfaction and retention has become a matter of concern in the banking industry and service quality has been identified empirically as the driver of them. But, there are discrepancies between what the banks think is quality service and what the customers expect from the banks.

OBJECTIVES OF THE STUDY

- To determine the factors influencing the level of customer satisfaction in ICICI Bank.
- To assess the level of customer satisfaction on the quality of service provided by the ICICI Bank.
- To study customer preference about the ICICI Bank.

TOOLS FOR ANALYSIS

The primary data were coded, classified, tabulated and analysed. The statistical tools used for analysis of the study are:

- Simple percentage Analysis
- Ranking Correlation
- Likert scale Analysis

LIMITATION OF THE STUDY

- The study is restricted to ICICI Bank branches situated in Coimbatore City only.
- The study takes into analysis only the customer satisfaction of the account holders of ICICI Bank in Coimbatore.
- The result is obtained only by means of responses from the respondents, So there is a chance for misstatement.

FORMULA

Number of respondents

$$\text{Percentage} = \frac{\text{Number of respondents}}{\text{Total no. of respondents}} \times 100$$

Total no. of respondents

- The research has been restricted upto 120 respondents only.

REVIEW OF LITERATURE

Abhijith. M and RemyaVivek Menon (2018), Stated that there are many other factors like credibility, customer services, easiness of operations etc. which act as a driving factor for improving customer satisfaction. The study also shows that the banks with very high profit and closing stock price does not guarantee good customer satisfaction. From the study it is found that the net profit and closing stock of a bank does not have an impact in improving the customer satisfaction.

Shah Malav Vineshkumar and Bhavin Bhatt (2018), Examined that the majority of respondents are fulfilling their cash requirements through ATM service and they are also happy with the number of ATM’s available in their locality, but most of respondents are not happy with the transaction cost charged by banks for ATM service and their mechanism to address the grievances of the ATM customers.

DATA ANALYSIS AND INTERPRETATION

In this chapter the analysis and interpretation of “A study on customer’s satisfaction towards ICICI banking services with special reference to Coimbatore city”, is presented based on the opinion of samples of 120 respondents selected from Coimbatore city through a questionnaire containing 20 questions. These were analysed through three different tools and they are as follows,

Simple Percentage analysis Rank Correlation
Likert scale Analysis

SIMPLE PERCENTAGE ANALYSIS

Simple percentage analysis is the method to represent raw streams of data as a percentage for better understanding of collected data. Percentage analysis is applied to create a contingency table from the frequency distribution and represent the collected data for better understanding.

**TABLE 1**
TABLE SHOWING THE GENDER OF THE RESPONDENTS

S. NO.	GENDER	NO. OF RESPONDENTS	PERCENTAGE
1	Male	74	62
2	Female	46	38
	TOTAL	120	100

*(Source: Primary data)***INTERPRETATION**

Majority, 62% of the respondents are male.

The above table shows that out of total 120 respondents, 62% of the respondents are male and 38% of the respondents are female.

TABLE 2
TABLE SHOWING THE EDUCATIONAL QUALIFICATION OF THE RESPONDENTS

S. NO.	EDUCATIONAL QUALIFICATION	NO. OF RESPONDENTS	PERCENTAGE
1	Illiterate	17	14
2	Upto school level	20	16
3	Graduate	47	39
4	Post graduate	16	13
5	Professional	20	16
	TOTAL	120	100

*(Source: Primary data)***INTERPRETATION**

professional, 14% of the respondents are illiterate, 13% of the respondents are post graduate.

Majority, 39% of the respondents are graduate.

The above table shows that out of total 120 respondents, 39% of the respondents are graduate, 16% of the respondents are upto school level and

TABLE 3
TABLE SHOWING THE OCCUPATIONAL STATUS OF THE RESPONDENTS

S. NO.	OCCUPATION	NO. OF RESPONDENTS	PERCENTAGE
1	Employee	11	9
2	Employer	39	33
3	Professional's	60	50
4	Other's	10	8
	TOTAL	120	100

*(Source: Primary data)***INTERPRETATION**

The above table shows that out of total 120 respondents, 50% of the respondents are professional's, 33% of the respondents are employer, 9% of the respondents are employee, 8% of the respondents are other's.

Majority, 50% of the respondents are professional's.

RANK CORRELATION

A rank analysis is any of several statistics that measure an ordinal association, the relationship

between ranking of different ordinal variables or different ranking of the same variables, where a "ranking" is the assignment of the labels "first", "second", "third", etc., To different observation of a particular variable. A rank analysis measures of similarity between two rankings, and can be used to assess the significance of the relation between them. It is not necessarily a total order of object because two different objects can have the same ranking. The ranking themselves are totally ordered.



TABLE 4

TABLE SHOWING THE PREFERENCE LEVEL OF RESPONDENTS TOWARDS ICICI BANKING SERVICES

S. No.	Factors	Rank 1	Rank 2	Rank 3	Rank 4	Rank 5	Total	Rank
1	Quality of service	23(5)	14(4)	42(3)	29(2)	5(1)	360	1
2	Timely response	12(5)	25(4)	21(3)	39(2)	20(1)	321	2
3	Loan facilities	5(5)	14(4)	29(3)	47(2)	19(1)	281	5
4	Internet banking	19(5)	2(4)	24(3)	44(2)	27(1)	290	4
5	Mobile banking	19(5)	15(4)	14(3)	38(2)	32(1)	305	3

(Source: Primary data)

INTERPRETATION

The above table shows that out of total 115 respondents, Quality of service has ranked 1st, Timely response has ranked 2nd, Mobile banking has ranked 3rd, Internet banking has ranked 4th, Loan facilities has ranked 5th.

Majority, Respondents are satisfied with the Online services in ICICI Bank.

LIKERT SCALE ANALYSIS

Likert scales are the most broadly used method for scaling responses in research studies. Research questions that ask you to indicate your level of agreement, from strongly agree or highly satisfied to strongly disagree or highly dissatisfied, use the likert scale. In Likert scale method, a person’s attitude is measured by combining (additional or averaging) their responses across all items.

FORMULA

$$\sum fx$$

Likert scale = _____

Total number of respondents

Where,

F = Number of respondents X

= Likert scale value

$\sum fx$ = Total score

Mid value,

Mid-value indicates the middle most value of the Likert scale.

TABLE 5

TABLE SHOWING THE SATISFACTION LEVEL OF RESPONDENTS WITH THE ICICI BANK’S CORE BANKING FACILITY

S. NO.	SATISFACTION LEVEL	NO. OF RESPONDENTS (F)	LIKERT VALUE (X)	TOTAL (FX)
1	Highly Satisfied	27	5	135
2	Satisfied	47	4	188
3	Neutral	32	3	96
4	Dissatisfied	12	2	24
5	Highly dissatisfied	2	1	2
	TOTAL	120		445

(Source: Primary data)

Likert value = $\sum fx / \text{No. of Respondents}$
 = 445 / 120
 = 3.71

**INTERPRETATION**

Likert scale value is 3.71 which is greater than the mid value (3), so the respondents are feeling good

with the core banking facility provided by the ICICI Bank.

TABLE 6**TABLE SHOWING THE SATISFACTION LEVEL OF RESPONDENTS TOWARDS CUSTOMERS RELIABILITY IN ICICI BANK**

S. NO.	SATISFACTION LEVEL	NO. OF RESPONDENTS	LIKERT VALUE	TOTAL (FX)
		(F)	(X)	
1	Highly satisfied	29	5	145
2	Satisfied	24	4	96
3	Neutral	26	3	78
4	Dissatisfied	14	2	28
5	Highly dissatisfied	27	1	27
	TOTAL	120		374

(Source: Primary data)

Likert value = $\frac{\sum fx}{\text{No. of Respondents}}$
 = $\frac{374}{120}$
 = 3

INTERPRETATION

Likert scale value is 3 which is greater than the mid value (3), so the respondents are satisfied with the Customers reliability by the ICICI Bank.

FINDINGS, SUGGESTIONS AND CONCLUSION FINDINGS

- 74% of the respondents are of between the age 18 years – 27 years.
- 52.2% of the respondents are male.
- 69.6% of the respondents are single.
- 59% of the respondents are under graduate.
- 46% of the respondents are engaged in other activities.
- 51.8% of the respondent's family are earning upto Rs.2,50,000
- 69.3% of the respondents are maintaining savings account.
- 40% of the respondents are maintaining account for upto 2 years.
- 41.7% of the respondents find importance towards personal loan.
- 36.5% of the respondents find cost effectiveness.
- 32.5% of the respondents complain over the phone.
- 38.6% of the respondents find no response.

RANK ANALYSIS

- Majority, Respondents are satisfied with the Online services in ICICI Bank.

LIKERT SCALE

- Likert scale value is 4.02 which is greater than the mid value (3) and therefore the respondents are highly satisfied.
- Likert scale value is 3.97 which is greater than mid value (3), thus the respondents are having good level of core banking facility.
- Likert scale value is 3.62 is greater than mid value point (3), that results in a good level of customer relationship management
- Likert scale value is 4.03 which is greater than mid point value (3), that results in a highly satisfied level of fund transfer.
- Likert scale value is 3.97 is greater than mid point value (3) , which results in a satisfied level of cardless cash withdrawal.
- Likert scale value is 3.82 which is greater than mid value (3), that results in satisfied level of recurring deposits.
- Likert scale value is 3.78 which is greater than mid value (3) , resulting in a satisfied level of credit card payments.
- Likert scale value is 3.51 which is greater than the mid point value (3), thus resulting in a satisfied level of fixed deposits.
- Likert scale value is 3.08 which is greater



than mid point value (3) thus resulting is

agreed level of catering the banking needs.

SUGGESTIONS

1. Bank should focus on loan services provided to their customers and should revise its interest on loan in a manner that people may go for loan.
2. Banks should share all the relevant information about the products and services with the customers
3. ICICI Bank should improve its Internet Banking and Mobile Banking Facilities as customers are not satisfied with it.

CONCLUSION

ICICI Bank is one of the largest private sector bank in India. Popularity of the bank is clear from the Survey done above. From analysis it is concluded that people mostly prefer ICICI Bank for Savings account needs because of its attractive interest rates and comfortable repayment system. Considerably less amount of people prefer this bank for maintain current accounts due to cumbersome documentation. ICICI is a diversified bank and has extended its operations into different areas like mutual funds, insurance etc. ICICI bank is known for its quality services and excellent customer care which is very evident from this survey customers are increasingly going tech savvy and hence ICICI bank has also worked hard in this domain. Overall, ICICI bank is the preferred bank by maximum people in private sector.

REFERENCE

1. Richa Dabas and Ritu Bajaj(2019), "A study on the impact of E-service Quality on user satisfaction in the online banking sector". *International Conference on Advancements in computing and Management Volume, pp.no.1-8.*
2. Abdul Khalique Talukder (2018), "Service quality and its impact on customer satisfaction in banking sector". *International journal of Management Technology and Engineering, Volume 8 Issue 11, ISSN 2249-7455 ,pp.no.341-349.*
3. Hussain Ajmal and Raza Ali Khan and Maham Fatima (2018), "Impact of service quality on customer satisfaction in banking industry in Pakistan", *Journal of Social and Administrative sciences, Volume 5 Issue 3, pp.no.219-238.*



A STUDY ON WORK-LIFE BALANCE OF WOMEN IN HANDLOOM INDUSTRY (WITH REFERENCE TO PALLADAM TOWN)

Madhubala. T

*Student of III B.com (PA), Department of Commerce with Professional Accounting,
Dr. N. G. P Arts and Science College, Coimbatore*

Dr. K. Vanaja

*Head Department of Commerce, Department of Commerce with Professional Accounting
Dr. N. G. P Arts and Science College, Coimbatore*

ABSTRACT

India has sufficient number of workers who are struggling their lives to have a promising future. A lot of handloom industry has been working throughout India providing employment to women. Likewise, women are facing a lot of difficulties to maintain their harmony between work and family commitments. This project mainly focuses on how women facing problems while working and balancing the family. The main objectives are to identify the barriers and the factors affecting the work-life balance of Women working in Handloom Industry, to understand the problems faced by the women by working in Handloom Industry, to provide suggestions to overcome work-life balance related to problems of weavers working in Handloom Industry. For better understanding of an analysis, the findings are interpreted in tables. This analysis consists of interpretation, findings and suggestion to obtain the overall worklife balance of women specially in handloom industry.

KEY WORDS: *Work life balance of women, family commitments, working women.*

INTRODUCTION

Recent days, women's empowerment has become a growing concern both at the national and international levels on the subjugated, the disadvantaged and status of women in the society. In India, this concern i.e. women's empowerment has to be focused mainly in non formal sectors, where the women's work force is predominant. One among them is handloom sector. It is one of the largest economic activities, after agriculture, providing direct and indirect employment as well as being predominately a non-farm activity.

STATEMENT OF THE PROBLEM

Nowadays the women workers in Handloom Industry faces lots of obstacles in their field of work. Workers are working for long hours and it results in

regular back pain, Neck pain, pain in fingers and hands & stress. They also face the problem of lack of respect from the Employees. In this study, work life balance of women is covered and overcoming measures are being analyzed.

SCOPE OF STUDY

This study is related to the work-life balance of the women in handloom industry in Palladam City. The study would enable to develop the work-life balance of women in Handloom sector. It talks about the consequences faced by women in handloom sector. It talks about how women balances her work-life, family and friends. It specifies about the health issues caused by working in handloom industry for women. The study covers about upto 20 industries in Palladam City.



OBJECTIVES OF THE STUDY

- To identify the barriers and the factors affecting the work-life balance of Women working in Handloom Industry.
- To understand the problems faced by the women by working in Handloom Industry.
- To provide suggestions to overcome work-life balance related to problems of weavers working in Handloom Industry.

RESEARCH METHODOLOGY

Research methodology is the specific procedures or techniques used to identify, select, process, and analyze information about a topic. In a research paper, the methodology section allows the reader to critically evaluate a study's overall validity and reliability.

SAMPLING TECHNIQUES

For the purpose of analysis, the data has been collected from 120 respondents from Palladam Town. The samples have been selected on the basis of Convenient Random Sampling Techniques.

SAMPLE SIZE

The sample of 120 respondents was chosen for the study.

AREA OF STUDY

The study is conducted within the Palladam Town.

SPECIAL TOOLS APPLIED

- Simple percentage analysis
- Likert scale analysis

LIMITATIONS OF THE STUDY

- The study was taken only from the weavers from various locations of Palladam city.
- As it was not possible to collect it from a particular industry, various Handloom sectors where chosen as samples.
- The sample size is restricted to 120.

LITERATURE REVIEW

Vasumathi(2018), the review of literature on work life balance of women employees has been outlined up in view of its increased popularity with the major objective to have prosperity of society. WLB is a major concern for women employees in today's scenario, as

extended work hours in the organisation pulls women employees' productivity and time which they actually meant to devote to their family sphere. The researcher has reviewed the literature on work life balance (WLB) of women employees with regard to significance of WLB, theories of WLB, determinants of WLB, facilitators of WLB, coping strategies of WLB, WLB and performance and finally, consequences of WLB. In this article, the researcher has dealt the various aspects of work life balance through the review of existing literature. The sources referred include various journals, books, doctoral thesis, working papers, reports, magazines, internet sites, etc., and has been reflected as references at the end.

Katta Rama Mohana Rao and Kakumanu Kiran Kumar (2018), handloom industry is the largest cottage industry providing widest avenues for employment opportunities, next to agriculture, prime thrust has been given to implementation of schemes for promotion and development of handloom sectors. From the beginning, co-operative has been considered to be the ideal infrastructural institution for implementation of various schemes for development of decentralized cottage industry like handlooms. Almost all schemes are therefore formulated co- operative oriented. Emphasis has also been laid upon formation of co-operatives with handloom weavers. The unorganized structure, weak financial base of the weavers etc. But the major and fundamental challenges are lack of innovative designs and inadequate fashion marketing.

Rachappa and M.P. Naik (2017), handlooms continue to occupy a prominent place in the country total economic output. It play vital role in country's economy. It is essentially a household industry and all the family members work as one unit as the head household performs the manufacturing work. Whereas other member of the family do the supporting or ancillary role. In general the socio-economic conditions force the weavers to depend upon the external agencies for infrastructural facilities. Some of them work independently; some of them organisations and others seek outside support. State government and central government are many handloom welfare schemes are introduced, due to lack of awareness and improper way of distribution still handloom weavers are suffering from financial support.

**DATA ANALYSIS AND INTERPRETATION****SIMPLE PERCENTAGE METHOD**

TABLE SHOWS THAT DOES IT EFFECTS PERSONAL LIFE BY WORKING MORE THAN AGREED NO. OF HOURS OF THE RESPONDENTS

EFFECTS PERSONAL LIFE	NO. OF RESPONDENTS	PERCENTAGE
Doesn't Affects	16	13.3%
Rarely Affects	29	24.2%
Sometimes Affects	50	41.7%
Never Affects	14	11.7%
Occasionally Affects	11	9.2%
Total	120	100

(Source: Primary Data)

INTERPRETATION

Table 4.1.8 reveals that 13.3% of the respondents said that working more than the agreed no. of hours Doesn't affects their personal life, 24.2% of the respondents said that working more than the agreed no. of hours rarely affects their personal life, 41.7% of the respondents said that working more than the agreed no. of hours sometimes affects the personal life, 11.7% of the respondents said that working more than the

agreed no. of hours never affects the personal life, 9.2% of the respondents said that working more than the agreed no. of hours occasionally affects the personal life.

- **Majority (41.7%) of the respondents said that working more than the agreed no. of hours sometimes affects their personal life.**

TABLE SHOWING THAT WHETHER THE RESPONDENTS WORKING MORE THAN AGREED NO. OF HOURS IN HANDLOOM INDUSTRY

WORKS MORE THAN AGREED HOURS	NO. OF RESPONDENTS	PERCENTAGE
Never	14	11.7%
Generally	26	21.7%
Often	23	19.2%
Sometimes	55	45.8%
Occasionally	2	1.6%
Total	120	100

(Source: Primary Data)

Interpretation

Table 4.1.7 reveals that 11.7% of the respondents never works more than the agreed number of hours, 21.7% of the respondents generally works more than the agreed no. of hours, 19.2% of the respondents often works more than the agreed no. of hours, 45.8% of the respondents sometimes works more

than the agreed no. of hours, 1.6 % of the respondents Occasionally works more than the agreed no. of hours.

- **Majority (45.8%) of the respondents sometimes works more than the agreed no. of hours.**

**TABLE SHOWING HOW THE RESPONDENT MANAGES THE WORK AND FAMILY**

FACTORS	NO. OF RESPONDENTS	PERCENTAGE
Technology like cell phones	33	27.5%
Spending time with family	40	33.3%
Support from Colleagues at work	24	20%
Being able to bring children work on occasion	20	18.3%
Others	3	0.9%
Total	120	100%

*(Source: Primary Data)***INTERPRETATION**

Table 4.1.9 reveals that 27.5% of the respondents were managing the work-life & family with the technology like Cell Phones, 33.3% of the respondents were managing the work-life & family by spending time with family, 20% of the respondents were managing the work-life & family with Support from Colleagues at work, 18.3% of the respondents

were managing the work-life & family by bringing children work on occasion, 0.9% of the respondents were managing the work-life & family with other things.

- **Majority (33.3%) of the respondents were managing the work-life & family by spending time with family.**

LIKERT SCALE ANALYSIS**TABLE SHOWING THE LEAVE PROVIDED TO THE RESPONDENTS WHILE HAVING HEALTH ISSUES**

FACTORS	NO. OF RESPONDENTS	LIKERT SCALE VALUE(x)	TOTAL SCORE (fx)
Strongly Agree	43	5	215
Agree	45	4	180
Neutral	26	3	78
Disagree	4	2	8
Strongly Disagree	2	1	2
Total	120		483

(Source : Primary Data)

$$\begin{aligned} \text{Likert Scale} &= \frac{\sum (fx)}{\text{Number of respondents}} \\ &= \frac{483}{120} \\ &= 4.03 \end{aligned}$$

The Likert Scale Value is 4.03 is higher than the Mid- value(3) so the respondents agrees that management provides leave while having health issues

FINDINGS, SUGGESTIONS AND CONCLUSION**FINDINGS OF THE STUDY****Findings of Simple Percentage Analysis**

- It is found that Majority (37.4%) of the respondents belong to the age group 26-35 Years.
- It is found that Majority (79.2%) of the respondents are Married.

- It is found that Majority (55.8%) of the respondents belongs to the joint family.
- It is found that Majority (38.3%) of the respondents were completed Under Graduate.
- It is found that Majority (32.5%) of the respondents income were Below Rs. 20000.
- It is found that Majority (34.2%) of the respondents were working in the handloom industry Below 5 Years.



- It is found that Majority (45.8%) of the respondents sometimes works more than the agreed no. of hours.
- It is found that Majority (41.7%) of the respondents said that working more than the agreed no. of hours sometimes affects their personal life.
- It is found that Majority (33.3%) of the respondents were managing the work-life & family by spending time with family.
- It is found that Majority (36.7%) of the respondents bring the children on occasions only to their work place on holidays.
- It is found that Majority (41.7%) of the respondents were managing stress by Spending time with family.
- It is found that Majority (70.8%) of the respondents work place provides transportation facility.
- It is found that Majority (36.7%) of the respondents were travelled by Own Vehicles.
- It is found that Majority (30.8%) of the respondents provided holidays for two days in a month.
- It is found that Majority (35%) of the respondents receiving Rs. 1501- Rs. 2000 per month as Overtime.
- It is found that The Likert Scale Value is 4.18 higher than the Mid- value (3) so the respondents agrees that all the employees are equal in the Handloom Industry.
- It is found that The Likert Scale Value is 3.96 is higher than the Mid- value(3) so the respondents agrees that management immediately taking action when they meet personal issues.
- It is found that The Likert Scale Value is 4.03 is higher than the Mid- value(3) so the respondents agrees that management provides leave while having health issues.
- It is found that The Likert Scale Value is 3.16 is higher than the Mid- value(3) so the respondents agrees that the employer provides insurance when get injured while weaving.
- It is found that The Likert Scale Value is 3.06 is higher than the Mid- value(2.5) so the respondents sometimes affects by working hours.
- It is found that The Likert Scale Value is 2.79 is higher than the Mid- value (2.5) so the respondents get sometimes affected by working on holidays.
- It is found that The Likert Scale Value is 2.72 is higher than the Mid- value(2.5) so the respondents sometimes affected while having excessive household works.

Findings of Likert Scale Analysis

- It is found that The Likert scale value is 2.46 is higher than the mid value (2) so the respondents always have problem in back while weaving.
- It is found that The Likert Scale value is 2.22 is higher than the Mid value (2) so the respondents are Always having problem in shoulder while leaving.
- It is found that The likert scale value is 2.13 is higher than the Mid value (2) so the respondents are Always having problem in Neck while weaving.
- It is found that The Likert Scale Value is 2.3 is higher than the Mid- value(2) so the respondents are Sometimes having problems in Hands while weaving.
- It is found that The Likert Scale Value is 2.03 is higher than the Mid- value(2) so the respondents are Always having problems in Hands while weaving.
- It is found that The Likert Scale Value is 1.87 is lesser than the Mid- value(2) so the respondents are Rarely having problems in knee while weaving.

SUGGESTION

- Only important function are to be attended by them...They are sacrificing their happiness but the management provides lot of work loads that they are not supposed to go to important events also
- It is not possible to be at two places at once and while multitasking is needed, it is not possible to do everything. They are asking to adjust their mistakes and take necessary actions promptly.
- If there is any issue, talking with your co-employees is effective to manage Ur problem. Don't shy for anything, if you want to know anything you can clear Ur doubt from Ur colleagues.

CONCLUSION

- The handloom sector plays a very important role in the country's economy. Work-life balance is the connection between the work-life and our lifestyles .



- It has been treated as important when both men and women equally share their responsibilities for the betterment of the family and also the society .
- Being a worker in handloom industry, a women faces a lot of obstacles and she needs some respect in her field.

REFERENCE

1. Vasumathi(2018), “*Work life Balance of Women Employees: A literature review,*” *International Journal of Services and Operations Management*”,29(1), 2018. 100-146
2. Katta Rama Mohana Rao and Kakumanu Kiran Kumar(2018), “*A Study of Quality of Work life of Weavers under Integrated Handloom Cluster Development Scheme(IHCDS)*” *International Journal of Research and Innovation in Social Science*,2(2): Febraury 2018,20-25.
3. Rachappa and Dr. N.P. Naik(2017),“*Welfare Schemes of Handloom Units in Karnataka with special reference to Kalaburagi District,International*” *Journal for Applied Research*:3(4), 2017, 494-498.



SAVING HABIT AND INVESTMENT AWARENESS AMONG THE RURAL HOUSEHOLD WITH SPECIAL REFERENCE TO NANJUNDAPURAM PANCHAYAT

Dr.M. Kalimuthu

*Assistant Professor, Department of commerce with professional accounting,
Dr.N.G.P. Arts and Science College, Coimbatore*

Manorabin.J

*Student of III B.Com (PA), Department of commerce with professional accounting,
Dr.N.G.P. Arts and Science College, Coimbatore*

ABSTRACT

The savings habits and investments awareness by the people vary from person to person and even with same person during two periods due to differ in motives. There are many motives for savings and their investments. However, capital appreciation, regular income, tax planning, diversification and minimization of risks, health and education of family members, performance of ceremonial activities like marriage, birth and death, purchase of fixed and current assets, construction of houses, etc, are the some important motives behind savings and investments in people. This study was analyzed with 120 respondents. Simple percentage method and ranking analyses were used for this study

INTRODUCTION

One can meet one's short term needs through one's savings but to meet long term goal one need to make investments. The ability to save depends on the level of income. To invest is to allocate money in the expectation of some benefit in the future. Savings in a general public relies upon two components, in particular the capacity to spare and the longing or impact for investment funds.

STATEMENT OF THE PROBLEM

- ✓ Whether the socio-economic background of rural households helps them to save and to invest.
- ✓ Whether the rural households are aware of various saving and investment schemes.
- ✓ What are their sources of income and expenditure.
- ✓ What are the factors determine their investment decision and What kinds of problems are faced by rural households while making investment.

OBJECTIVES

- ✓ To study the socio-economic status of the rural household.

- ✓ To analyse the problems which prevent the rural household from savings and investments.
- ✓ To examine the awareness of rural household towards various savings and investment avenues.

RESEARCH METHODOLOGY

The present study is an empirical one because it is mainly based on primary data. Besides, the secondary data were also collected from related to journals and online sources.

PRIMARY DATA AND SECONDARY DATA

- ✓ In primary data has been collected by using methods of questionnaire.
- ✓ The secondary data was collected from various possible records like books websites.

SAMPLING SIZE

The sample of 120 respondents were chosen for the study.

**AREA OF THE STUDY**

The study have been conducted in nanjundapuram panchayat.

REVIEW OF LITERATURE

Abhaykumar Gasti (2017) ¹“Saving and Investment Behaviour of Rural Household: an analytical Study of Households of Dharwad District of Karnataka State” saving and investment are the an integral part of our everyday life and it is hard for one to meet the normal and sudden uses without the best possible measure of saving and their reasonable investments. Almost certainly, there are numerous roads of investments accessible for financial specialists to put their investment funds in the present situation of market yet these roads have focused more on urban territories. In perspective on this, the provincial financial specialists are not approaching to contribute their saving because of absence of information to deal with their investment portfolio to amplify their arrival and to limit hazard.

Jyoti Mahadeo Patil (2017)² “A Study of Saving and Investment Pattern of Rural inhabitants relating to Postal and Banking Schemes” The saving from the household sector of India contributes a lion’s share to the total saving of the nation and has a major influence on the Indian economy. Saving rate of the household sector of both the rural and urban sectors should be stepped up to boost the saving and thus the Indian economy.

DATA ANALYSIS AND**INTERPRETATION****SIMPLE PERCENTAGE METHOD****WHERE DO YOU INVEST YOUR****SAVINGS OF THE RESPONDENTS**

S.NO	FACTORS	NO OF RESPONDENTS	PERCENTAGE
1	Fixed deposits	47	40
2	Stocks	28	23
3	Gold/silver	27	22
4	Real estate	18	15
	Total	120	100

INTERPRETATION

The table shows 40% of the respondents are 47 is invest your savings in fixed deposits and 23% of the respondents are 28 is invest your savings in stocks and 22% of the respondents are 27 is invest

¹ Abhaykumar Gasti “Saving and Investment Behavior of Rural Household: an analytical Study of Households of Dharwad District of Karnataka State”(2017) ISSN: 2454-1362

² Jyoti Mahadeo Patil “A Study of Saving and Investment Pattern of Rural inhabitants relating to Postal and Banking Schemes”(2017).

your savings in gold/silver and 15% of the respondents are 18 is invest your savings in real estate.

Majority 40% of the respondents are 47 is invest your savings in fixed deposits.

RANK ANALYSIS
RANKING OF THE INVESTMENT OF
RESPONDENTS KNOWLEDGE

S. NO	INVESTMENTS	RANK I	RANK II	RANK III	RANK IV	RANK V	RANK VI	TOTAL SCORE	RANK
1	Companies Shares & Bonds	74(6)	23(5)	12(4)	5(3)	2(2)	5(1)	631	1
2	Mutual Funds	12(6)	52(5)	35(4)	7(3)	7(2)	8(1)	515	2
3	Real Estate	13(6)	26(5)	37(4)	17(3)	15(2)	13(1)	460	4
4	Government Bonds & Securities	17(6)	19(5)	29(4)	21(3)	23(2)	12(1)	484	3
5	Long Term deposits in Banks/Post Office/Financial Institutions	8(6)	30(5)	23(4)	26(3)	25(2)	9(1)	427	6
6	Gold/Silver/Precious Stones and Metals	12(6)	27(5)	26(4)	22(3)	19(2)	15(1)	430	5

INTERPRETATION

The table shows that the out of 120 respondents, Companies Shares & Bonds in the rank 1, Mutual Funds in the rank 2, Real Estate in the rank 4, Government Bonds & Securities in the rank is 3, Long Term deposits in Banks/Post Office/Financial Institutions in the rank is 6, Gold/Silver/Precious Stones and Metals in the rank is 5

Majority of the respondents have knowledge about Companies Shares & Bonds. So rank 1 is company shares & bonds.

FINDING, SUGGESTIONS AND**CONCLUSION****FINDINGS****SIMPLE PERCENTAGE ANALYSIS**

- ✓ Majority 28% of the respondents are 20-25 years and 25-30 years.
- ✓ Majority of 63% of the respondents are 75 male.
- ✓ Majority 46% of the respondents are 55 is have owned house.
- ✓ Majority 38% of the respondents are 46 is own decision makers.



- ✓ Majority 40% of the respondents are 47 is invest your savings in fixed deposits.
- ✓ Majority 50% of the respondents are 60 is aware of bank deposits.
- ✓ Majority 38% of the respondents are 46 is low risk investor.
- ✓ Majority 32% of the respondents are 39 purpose of investment is emergency need.
- ✓ Majority 28% of the respondents are 33 is Lack of awareness of savings and investment.

RANKING ANALYSIS

- ✓ Majority of the respondents have knowledge about Companies Shares & Bonds. So rank 1 is company shares & bonds.

SUGGESTIONS

- ✓ As the majority of the respondents are focusing on conventional roads of investment, mindfulness ought to be made towards present day venture roads which help them to show signs of improvement return.
- ✓ As the capacity to save and invest depends mainly on life style, government should take necessary steps to change their life style to suit the changed economic scenario.
- To enhance the saving habits of rural mass, they ought to be spurred by potential methods.
- Mindfulness must be made among provincial mass towards deluding promotion and speculation misrepresentation of the private associations engaged with doing reserve funds and venture business.

- ✓ Steps must be taken to open mail station branch and bank office in every single rustic territory. So the rustic family unit can have simple access to such establishments to set aside and put away their cash.

CONCLUSION OF THE STUDY

Most of the respondents are aware of various savings and investment avenues. But their awareness level towards modern savings and investment avenues is low. In most cases, most of them suffer from lack of information to make savings and investment decision. The study concludes that there is a need to improve the financial literacy of the rural masses.

REFERENCE

1. *Abhaykumar Gasti "Saving and Investment Behavior of Rural Household: an analytical Study of Households of Dharwad District of Karnataka State"(2017) ISSN: 2454-1362*
2. *Jyoti Mahadeo Patil "A Study of Saving and Investment Pattern of Rural inhabitants relating to Postal and Banking Schemes" (2017).*
3. *Madhumala Pathy "Saving and investment habit of rural households in Cuttack district of Odisha"(2017) ISSN: 2455-1627.*
4. *P Girija, R Kalaivani "The study on saving habits of rural women's with special reference to Pollachi" ISSN: 2455-4197 (2018).*
5. *Dr.M.S.Ramaratnam, Dr.R.Jayaraman "A Study on Saving Pattern of Rural Households in the Select Clusters of Kanchipuram Districts" (2016) ISSN (ONLINE): 2250-0758, ISSN (PRINT): 2394-61202.*
6. *Mr. Sam Jeyachandran "savings habit of rural people" (2016) ISSN (O)-2395-43120.*



A STUDY ON CONSUMER BUYING BEHAVIOUR OF RETAIL TEXTILE SHOPS (WITH REFERENCE TO TIRUPPUR REGION)

Dishath Kumar. S

*Student of III B.com (PA), Department of Commerce with Professional Accounting,
Dr. N. G. P Arts and Science College (Autonomous), Coimbatore*

Mr. R. Mayilsamy

*Assistant professor, Department of Commerce with Professional Accounting,
Dr. N. G. P Arts and Science College (Autonomous), Coimbatore*

ABSTRACT

A large number of Textile shops running successfully throughout India. It has a wide variety of clothings and a unique style of dresses which attracts every individual. The textile shops have been developing in every area which is sufficient to all people. This study analysis the consumer buying behaviour retail textile shops with special reference to Tiruppur Region. It analyses the factors which influences the consumer to buy in retail textile shops. This study analyses the average time spent by the consumers in retail shops and many other factors. Nowadays, there are many sources of selling dresses through online trading, wholesale and retail selling, etc.. But retail trading has become enormous in almost every region. This study not only analysis the buying behaviour of consumer but also studies the experience of salesman in retail textile shops.

KEY WORDS: Retail textile shop, Buying behaviour, consumer influence.

INTRODUCTION

The Indian textiles industry is extremely varied, with the hand-spun and hand-woven textiles sectors at one end of the spectrum, while the capital-intensive sophisticated mills sector at the other end of the spectrum. The decentralised power looms/ hosiery and knitting sector form the largest component of the textiles sector. The Indian textile industry has the capacity to produce a wide variety of products suitable to different market segments, both within India and across the world.

STATEMENT OF PROBLEM

Textile industry in India is growing at a very faster rate. New upcoming technologies and products

are to be absorbed by the industries. Attempts are required in analysing the functioning of powerloom industry. The study of consumer awareness of buying behaviour of textiles is studied in detail. Appropriate measures for the problems in interest of weavers, traders and consumers will be given.

SCOPE OF STUDY

The study focuses on the buying behaviour about textile products, factors influencing the buying decision of textiles and the relationship between consumer preference and product attributes. But the study is undertaken only on factors influencing buyer behaviour on male, female and children readymade dresses and it excludes all other home textiles. The study covers the consumers of



Tiruppur city only. It analyses the consumers in that particular surroundings.

➤ The sample size was restricted to 120.

OBJECTIVES OF THE STUDY

- To study buying behaviour and need for buying textile products.
- To identify different sources of information and the effect in motivating consumer preference.
- To offer suggestions and recommendations to dealers and manufactures to maximise services to textile consumers.

RESEARCH METHODOLOGY

Research methodology is the specific procedures or techniques used to identify, select, process, and analyze information about a topic. In a research paper, the methodology section allows the reader to critically evaluate a study's overall validity and reliability.

SAMPLING TECHNIQUES

For the purpose of analysis, the data has been collected from 120 respondents from Tiruppur Region. The samples have been selected on the basis of Convenient Random Sampling Techniques.

SAMPLE SIZE

The sample of 120 respondents was chosen for the study.

AREA OF STUDY

The study is conducted within the Tiruppur city.

SPECIAL TOOLS APPLIED

- Simple percentage analysis
- Likert scale analysis

LIMITATIONS OF STUDY

- The study was taken only from the female customers from various locations of Tiruppur City.
- As it was not possible to collect data from all regions, only particular places were taken for study.

LITERATURE REVIEW

Pearl fafa bansah michael dabi sheena anita edem dzorvakpor (2015), the study examined the effect of branding on consumer buying behaviour among Textile Ghana Fabric (formally known as Ghana Textile Prints) users in the Ho municipality. Three aspects of brand equity, notably brand awareness, brand loyalty and brand image were all addressed with other factors that affect the buying behaviour of consumers. Findings revealed that branding (brand equity) accompanied with other factors of price, status, self-concept and lifestyle are key components in influencing a customer's purchase decision in the fabric industry.

Leena Jenefa, Ramesh Kaliyamoorthy(2014), with high level of competition, higher customer turnover, improved technology leads to more customer expectations in today competitive world. As far as retail industry is concerned due to global developments and lifestyle changes, the retail sector business models and strategies changed now. Retaining the customer by providing an unique and holistic assessment of the benefits and challenges by experiential innovation is vital for success. The beyond level of customer satisfaction leads to customer delight. It is very difficult to fulfill the customer expectations.

Lee Jungmin Kim Jongjun(2010), nowadays people are turning to have a more intimate environment-friendly lifestyles. In the clothing industry they are focusing on making products that are more human-friendly and not harmful to the environment. In the midst of the spread of consumption research is being done to develop manufacturing textiles that do not induce pollution. For instance, advantages of the natural textile fibers, cotton, silk, and ramie, have been newly recognized in terms of environment-friendliness. Together with these fibers, the natural high molecular materials, such as chitosan and hyaluronic acid, have found new roles in the application sectors of human-friendliness and environment-friendliness.



DATA INTERPRETATION AND ANALYSIS

SIMPLE PERCENTAGE ANALYSIS

TABLE SHOWING THE AVERAGE TIME SPENT IN RETAIL TEXTILE SHOPS OF THE RESPONDENTS

TIME SPENT	NO. OF RESPONDENTS	PERCENTAGE
Less than 30 Minutes	31	24.8%
30 Mins – 1 hour	54	43.2%
1 Hour – 2 Hour	31	24.8%
More than 2 hours	9	7.2%
Total	125	100%

(Source: Primary Data)

INTERPRETATION

Table 4.1.8 reveals that 24.8% of the respondents spent less than 30 minutes, 43.2% of the respondents spent 30 minutes-1 hour, 24.8% of the

respondents spent 1 hour-2 hour, 7.2% of the respondents spent More than 2 hours.

- **Majority (43.2%) of the respondents spent 30 mins – 1 hour.**

TABLE SHOWING ON WHICH OCCASIONS THE CUSTOMERS MAKE PURCHASE

OCCASIONS	NO. OF RESPONDENTS	PERCENTAGE
Birthday	43	34.4%
Weddings	26	20.8%
Casual wear	48	38.4%
Gifts	8	6.4%
	125	100%

(Source: Primary Data)

INTERPRETATION

Table 4.1.10 reveals that 34.4% of the respondents Purchase clothes for Birthday, 20.8% of the respondents purchase clothes for Weddings, 38.4%

of the respondents purchase clothes for Casual Wears and 6.4% of the respondents purchase clothes for Gifts.

- **Majority (38.4%) of the respondents purchase dress for Casual wears.**

TABLE SHOWING THAT ON AVERAGE HOW OFTEN THE CUSTOMERS VISIT TEXTILE SHOPS

FACTORS	NO. OF RESPONDENTS	PERCENTAGE
Once in a week	24	19.2%
Once in a month	55	44%
Twice in a month	25	20%
Often	21	16.8%
	125	100%

(Source: Primary Data)

INTERPRETATION

Table 4.1.12 reveals that 19.2% of the respondents visit retail textile shops Once in a week, 44% of the respondents visit once in a month, 20% of

the respondents visit twice in a month,16.8% of the respondents visit often.

- **Majority (44%) of the respondents visit textile shops once in a month.**

**LIKERT SCALE ANALYSIS****TABLE SHOWING THE REASONABLE PRICE**

FACTORS	NO. OF RESPONDENTS	LIKERT SCALE VALUE(x)	TOTAL SCORE (fx)
Very High	32	5	160
High	36	4	144
Neutral	51	3	153
Low	5	2	10
Very Low	1	1	1
Total	125		468

(Source : Primary Data)

$$\begin{aligned} \text{Likert Scale} &= \sum (fx) / \text{Number of respondents} \\ &= 468/125 \\ &= 3.74 \end{aligned}$$

The Likert Scale Value is 3.74 higher than the Mid-value (3) so the respondents agree that reasonable price is high in buying retail textile shops.

FINDINGS, SUGGESTION AND CONCLUSION**FINDINGS OF THE STUDY****Findings of Simple Percentage analysis**

- It is found that the Majority (60%) of the respondents belong to the age group 18-25 Years.
- It is found that Majority (68.8%) of the respondents are Female.
- It is found that Majority (52.8%) of the respondents were completed Under Graduate.
- It is found that Majority (76%) of the respondents are Unmarried.
- It is found that Majority (52.8%) of the respondents were Self Employed.
- It is found that Majority (51.2%) of the respondents belongs to the Nuclear family.
- It is found that Majority (36.8%) of the respondents income were Below Rs. 20000.
- It is found that Majority (43.2%) of the respondents spent 30 mins – 1 hour.
- It is found that Majority (41.6%) of the respondents who accompanies to purchase was Friends.
- It is found that Majority (38.4%) of the respondents purchase dress for Casual wears.
- It is found that Majority (41.6%) of the respondents prefer to visiting shops to buy clothes.

- It is found that Majority (44%) of the respondents visit textile shops once in a month.
- It is found that Majority (37.6%) of the respondents spent between Rs.1000-Rs.2000.
- It is found that Majority (39.2%) of the respondents textile shop experience was Selection of items.
- It is found that Majority (31.2%) of the respondents were influenced by Friends to buy in retail textile shops.

Findings of Likert Scale Analysis

- The Likert Scale Value is 4.30 higher than the Mid- value (3) so the respondents agrees that nearer to home is very high to buy in retail textile shops.
- The Likert Scale Value is 3.74 is higher than the Mid- value (3) so the respondents agree that the availability of stores is High to buy in retail textile shops.
- The Likert Scale Value is 3.74 higher than the Mid- value (3) so the respondents agree that reasonable price is high in buying retail textile shops.
- The Likert Scale Value is 3.58 higher than the Mid- value (3) so the respondents agrees that extension of credit is High in buying retail textile shops.
- The Likert Scale Value is 3.65 higher than the Mid- value (3) so the respondents agrees that salesman's approach is high in buying retail textile shops.
- The Likert Scale Value is 3.84 higher than the Mid- value (3) so the respondents agrees that



collecting information about recent selling brands and designs is High.

- The Likert Scale Value is 3.63 higher than the Mid- value (3) so the respondents agrees that collecting information about the price at different places is High.
- The Likert Scale Value is 3.80 higher than the Mid- value (3) so the respondents agrees that looking for the variety of dress is high.
- The Likert Scale Value is 3.53 higher than the Mid- value (3) so the respondents agrees that discussion with friends to buy quality products at high cost is High.
- The Likert Scale Value is 3.54 higher than the Mid- value (3) so the respondents agrees that comparing the quality proportionate to price is High.
- The Likert Scale Value is 4.06 higher than the Mid- value (3) so the respondents strongly agrees that Casual wear with best quality are their choices.
- The Likert Scale Value is 3.77 higher than the Mid- value (3) so the respondents agrees that the respondents prefer to buy the best choice .
- The Likert Scale Value is 3.70 higher than the Mid- value (3) so the respondents agrees that all the respondents purchase the dress with much thought and care.
- The Likert Scale Value is 3.66 higher than the Mid- value (3) so the respondents agrees that all the respondents use much time and effort to buy the best clothes.

SUGGESTIONS

- ❖ Customer satisfaction is an important thing in retail business. Likewise the textile industry provides lot of satisfaction to the customers with the quality products at low price.
- ❖ There are a lot of source of textile in Tiruppur . But retail textile shops have its own way of marketing in Tiruppur.
- ❖ Comparing to online shopping, Retail textile shopping is the best way of purchasing clothes because the quality and the price of the materials may vary, but we have assurance of clothes.
- ❖ Comparing to Big shops, Retail shops have a unique way of dressing and they approach the customers effectively.

CONCLUSION

- The major impact of the study is to analyse the buying behaviour of consumers in retail textile shops and it has given a lot of informations which has to be appreciated and to be corrected.
- The major impact of this study is that there are a lot of circumstances faced by a retail shop owner because the opinion of customers vary in every situations.
- Some customers buy the product within a few minutes whereas few customers take a long time to purchase a single cloth.They have to arrange all the things before the next customer's arrival.

REFERENCE

1. Pearl Fafa Bansah Michael Dabi Sheena Anita Edem Dzorvakpor(2015) , "The Effect of Branding on Consumer Buying Behaviour among Textile Ghana Fabric Users in the Ho Municipality of Ghana" *European Journal of Business and Management* ISSN 2222-1905 (Paper) ISSN 2222-2839 (Online) Vol.7, No.26, 2015.
2. Leena Jenefa, Ramesh Kaliyamoorthy(2014), *Behavioral Impact of Customer Satisfaction and Customer Retention in Textile Industry. "International Journal on Global Business Management and Research"* ISSN 2278 8425 Volume 2, Issue 2, March 2014
3. Lee Jungmin Kim Jongjun(2010) , "A Study on Consumer Behavior and Preference towards Textile materials with Environment-Friendly treatment", *Journal of fashion business*, Volume 14 ,No 3 pp. 128-145.



A STUDY ON FINANCIAL PERFORMANCE OF MAHINDRA AND MAHINDRA COMPANY

Mr. P. Kanagaraj

*Assistant Professor, Commerce with Professional Accounting,
Dr. N.G.P. Arts and Science College (Autonomous), Coimbatore – 641048*

S. Loga Priya

*III-B.COM (Professional Accounting), Commerce with Professional Accounting,
Dr. N.G.P. Arts and Science College (Autonomous), Coimbatore – 641048*

ABSTRACT

This study main focus on to analysis the overall performance of the Mahindra and Mahindra Company to analysis the overall performance with the help of financial statement with shows all incomes and expenditure and assets and liabilities in the format of profit & loss and balance sheet this statement is analyzed it is called performance it help the firm take any decision and to get knowledge about their function of financial aspects in business .The method used to analysis their performance was ratio analysis (liquidity ,profitability and activity) and schedule changing in working capital this method help to analysis their performance of the company .

KEYWORDS: *Financial performance analysis, Ratio Analysis*

INTRODUCTION

Finance is a broad term that describes activities associated with banking, leverage or debt, credit, capital markets, money, and investments. Financial performance is an important which influences the profitability and liquidity of organization. There are many ways to measure financial performance but all measures should be taken in aggregate. Financial performance is a process of measuring and resulting a financial activity of the firm. The aim of this study to analysis the financial performance of the company by using the financial tools. The study is based on financial statements such as ratio analysis and common size balance sheet by using the tools combined it enables to determine in an effective manner.

STATEMENT OF THE PROBLEM

One of the most fundamental facts about business is that the financial performance of the firm shapes its financial structure. As fast growing society for a business financial analysis of financial performance is important, and to be stable in this society. So it's needed to measure the efficiency functioning of the company. And, measure their

performance of activity. This helps to take financial decision for concern. On the above point of view, the research conducted the study on financial performance of the company.

SCOPE OF THE STUDY

In India, there is more automobile sector and there is more competition between them. The efficiency of business is important to measure the financial performance of the company. The present study will help to analyze the overall growth of the business and help to improve the financial performance of the company. The main scope of the study is to measure and identify the liquidity, profitability, solvency position and changes in working capital of the Mahindra and Mahindra Company.

OBJECTIVES OF THE STUDY

- To identify the liquidity position of the company.
- To evaluate the profitability capacity of the company.
- To analyze the working capital of Mahindra and Mahindra company.

**RESEARCH METHODOLOGY**

A research methodology or involves specific techniques that are adopted in research process to collect, assemble and evaluate data. It defines those tools that are used to gather relevant information in a specific research study.

SOURCES OF DATA

The data was collected from secondary data for five years financial statement of the company. And, the relevant information were gathered from the official websites and journals etc...

PERIOD OF STUDY

The present study covers over a period of 5 years from 2014 – 2015 to 2018 – 2019.

TOOLS AND TECHNIQUES

Data was collected from the secondary source in the form of annual report was analyzed using the tools, ratio analysis and statement of working capital. The above tools were used to measure and to analysis financial performance of Mahindra and Mahindra Company.

LIMITATION OF THE STUDY

- Since, there are many automobile sectors, it was only able to analyze one firm for this study.
- It was only able to measure 5 years of performance of the company.

REVIEW OF LITERATURE

Raja Narayanan Sandhir Sharma (2019) conducted study on financial performance of Maruti Suzuki to assess the attention of the numerous collections linked to a business and affected by the economic presentation of the business. The various tools and techniques were used trend analysis, ratio analysis on this study. An analysis comprises measuring the accounting principles and the financial position of the company. Finally, the company has it financial trend in uphill order from preceding five years on this study.

Suman Rana (2019) The study evaluated the financial analysis of Tata motors and Maruti Suzuki to analyze the performance of both company. The data was collected secondary data and certain tools like ratio analysis had used. Tata motors had more ability in payment ratios as higher than Maruti Suzuki, the overall volume of Maruti Suzuki is more efficient.

FINANCIAL ANALYSIS AND INTERPRETATION**RATIO ANALYSIS****CURRENT RATIO**

The current ratio is the difference between a company's current assets (net of cash) and current liabilities (net of debt) on its balance sheet. It is a measure of a company's liquidity and its ability to meet short-term obligations.

Current Ratio =

$$\text{Current Assets} / \text{Current Liabilities}$$

TABLE 1 SHOWING CURRENT RATIO

S.NO	YEAR	CURRENT ASSETS (in thousands)	CURRENT LIABILITY (in thousands)	CURRENT RATIO
1	2014-2015	18,841.38	27,937.24	0.67
2	2015-2016	19,461.27	33,063.70	0.59
3	2016-2017	20,739.30	33,678.15	0.62
4	2017-2018	24,372.99	41,869.59	0.58
5	2018-2019	30,225.58	55,263.32	0.55

INTERPRETATION

The above table shows on performance of current ratio. In 2014-2015 the ratio was 0.67:1, next year in 2015-2016 it decreased to 0.59:1, in 2016-2017 it increased to 0.62:1 and then it decreased to 0.58:1 and 0.55:1 in 2017- 2018 and 2018-2019, it shows that decreasing in their performance. The current ratio shows highest level of growth in 2014-2015 at 0.07:1 and lowest level of growth in 2018-2019 at 0.55:1.

LIQUID RATIO

The other important one of the liquidity ratios is Quick Ratio, also known as a liquid ratio or acid test ratio. This ratio will measure a firm's ability to pay off its current liabilities (minus a few) with only selling off their quick assets.

Liquid Ratio =

$$\text{Current Assets} / \text{Quick Liabilities}$$

**TABLE 2 SHOWING LIQUID RATIO**

S.NO	YEAR	LIQUID ASSETS (in thousands)	LIQUID LIABILITY (in thousands)	LIQUID RATIO
1	2014-2015	10,387.99	27,937.24	0.37
2	2015-2016	10,345.15	33,063.70	0.31
3	2016-2017	11,853.29	33,678.15	0.35
4	2017-2018	15,037.42	41,869.59	0.36
5	2018-2019	18,025.42	55,263.32	0.33

INTERPRETATION

The above table shows on performance of liquid ratio. In 2014- 2015, the ratio was 0.37:1, next year in 2015- 2016 it decreased to 0.31:1 and it increased to 0.35:1 in 2016- 2017 and then in 2017-2018 it increased to 0.36:1 and decreased to 0.33:1 in 2018- 2019. So, it indicates that there was a normal growth in these five years but it has both ups and downs equally. The liquid ratio has highest growth in 2014-2015 at 0.37:1 and lowest level of growth in 2015-2016 at 0.31:1.

ABSOLUTE LIQUID RATIO

It's a modified form of liquid ratio. The relationship of absolute liquid assets to liquid liabilities is known as absolute liquid ratio. This ratio is also called as "super quick ratio" the ratio is calculated as.

Liquid ratio =

Absolute liquid assets \ Current liabilities

TABLE 3 SHOWING ABSOLUTE LIQUID RATIO

S.NO	YEAR	ABSOLUTE LIQUID ASSETS (in thousands)	CURRENT LIABILITY (in thousands)	ABSOLUTE LIQUID RATIO
1	2014-2015	4911.83	27,937.24	0.18
2	2015-2016	4527.55	33,063.70	0.14
3	2016-2017	4654.03	33,678.15	0.14
4	2017-2018	6547.6	41,869.59	0.16
5	2018-2019	8734.91	55,263.32	0.16

INTERPRETATION

The above table shows on performance of absolute cash ratio. In 2014-2015, the ratio was 0.18:1 and next year in 2015- 2016 it decreased to 0.14:1 and in 2016-2017 it has no change it has same growth at 0.14:1 and next in 2017- 2018 it increased to 0.16:1 and in 2018- 2019 it has no change at 0.16:1 it has average growth it decreases in certain stage and again it increases it has a rapid growth. The absolute liquid ratio has highest growth in 2014-2015 at 0.18:1 and the lowest level of growth in both 2015-2016 and 2016- 2017 at 0.14:1.

PROFITABILITY RATIOS

Efficiency of a business is measured by profitability. Profitability ratio measures the profit earning capacity of the business concern.

GROSS PROFIT RATIO

This ratio indicates the efficiency of trading activities. The relationship of Gross profit To sales is known as Gross profit ratio.

Gross profit ratio =Gross Profit / Sales * 100

**TABLE 4 SHOWING GROSS PROFIT RATIO**

S.NO	YEAR	Gross profit (in thousands)	SALES (in thousands)	Gross profit ratio
1	2014-2015	21,306.86	75,489.82	28.22
2	2015-2016	26,686.76	80,461.87	33.17
3	2016-2017	28,485.17	88,983.03	32.01
4	2017-2018	28,786.81	93,264.77	30.87
5	2018-2019	31,586.13	104,720.68	30.16

INTERPRETATION

The above table shows on performance of gross profit ratio. In 2014- 2015, the ratio was 28.22% and next year in 2015-2016 it increased to 33.17%, then decreased to 32.01% in 2016- 2017 and in 2017-2018 it decreased to 30.87% and in 2018-2019 it decreased to 30.16%. So it shows that the gross profit ratio has growth and has healthy performance .The gross profit ratio has high level of

performance in 2015-2016 at 33.01% and lowest growth in 2014-2015 at 28.22%.

NET PROFIT RATIO

This ratio determines the overall efficiency of the business. The relationship to sales is known as of net profit ratio.

Net profit ratio= Net Profit/ Sales * 100

TABLE 5 SHOWING NET PROFIT RATIO

S.NO	YEAR	Net profit (in thousands)	SALES (in thousands)	Net profit ratio
1	2014-2015	2,592.68	75,489.82	3.43
2	2015-2016	2,708.47	80,461.87	3.37
3	2016-2017	2,798.64	88,983.03	3.15
4	2017-2018	6,403.13	93,264.77	6.87
5	2018-2019	3,948.94	104,720.68	3.77

INTERPRETATION

The above table shows on performance of net profit ratio. In 2014- 2015, the ratio was 3.43%, next year in 2015-2016 it decreased to 3.37% and in 2016-2017 it decreased to 3.15%, then it increased in 2017- 2018 at 6.87% and 2018-2019 decreased to of 3.77% . This interpretation present that the net profit has no healthy performance as they have a normal level of performance. The net profit ratio has high

level of performance in 2017-2018 at 6.87% and lowest growth in 2016-2017 at 3.15%.

OPERATING PROFIT RATIO

This ratio is an indicator of the operational efficiency of the management. It establishes the relationship between Operating profit and sales.

Operating profit ratio=

Operating Profit Ratio / Sales * 100

TABLE 6 SHOWING OPERATING PROFIT RATIO

S.NO	YEAR	OPERATING PROFIT (in thousands)	SALES (in thousands)	OPERATING PROFIT RATIO
1	2014-2015	8,793.29	75,489.82	11.65
2	2015-2016	14,702.89	80,461.87	18.27
3	2016-2017	10,734.83	88,983.03	12.06
4	2017-2018	13,226.10	93,264.77	14.18
5	2018-2019	15,206.51	104,720.68	14.52

**INTERPRETATION**

The above table shows on performance of operating profit ratio. In 2014- 2015, the ratio was 11.65% and next year in 2015-2016 it increased to 18.27%, then in 2016-2017 it decreased to 12.06% and in 2017- 2018 it increased to 14.18% and it increased in 2018-2019 at 14.52%. This interpretation states that the operating profit has not healthy performance as they have a normal level of performance The operating profit ratio has high level of performance in 2015-2016 at 18.27% and lowest growth in 2014- 2015 at 11.65%.

OPERATING RATIO

This ratio determines the operating efficiency of the business concern operating ratio measures the amount of expenditure incurred in production, sales and distributions of output.

Operating ratio=

Cost of goods sold + Operating expense \ sales *100

TABLE 7 SHOWING OPERATING RATIO

S.NO	YEAR	OPERATING PROFIT RATIO	OPERATING RATIO
1	2014-2015	11.65	88.35
2	2015-2016	18.27	81.73
3	2016-2017	12.06	87.94
4	2017-2018	14.18	85.82
5	2018-2019	14.52	85.48

INTERPRETATION

The above table shows on performance of operating ratio. In 2014-2015, the ratio was 88.35% and next year in 2015-2016 it decreased to 81.73% then in 2016-2017 it increased to 87.94% and in 2017-2018 it decreased to 85.82% and it decreased in 2018-2019 at 85.48%. So it shows that the operating ratio has growth and has healthy performance. The operating ratio has high level of growth in 2014-2015 at 88.35% and low level of performance in 2015-2016 at 81.73%.

EXPENSES RATIO

Expenses ratio is computed to show the relationship an individual expense or group of expense and sales. It is computed by dividing a particular expenses or group of expenses by net sales. It is expressed in percentage.

Expense Ratio =

Total expenses / Net Sales *100

TABLE 8 SHOWING EXPENSES RATIO

S.NO	YEAR	TOTAL EXPENSES (in thousands)	NET SALES (in thousands)	EXPENSES RATIO
1	2014-2015	62,881.17	71,948.59	87.39
2	2015-2016	66,217.49	80,461.87	82.29
3	2016-2017	73,052.05	83,773.05	87.20
4	2017-2018	78,784.52	92,093.95	85.55
5	2018-2019	91,244.65	1,04,720.68	87.13

INTREPRETATION

The above table shows about expenses ratio , In 2015 the ratio was 87.39 %and in 2016 it decreased to 82.29% then in 2017 the ratio was increases to 87.20% and in 2018 it decreased to 85.55% and in 2019 it increased to 87.13%. It should be kept in minimum level and they need to reduce the expenses ratio.

ACTIVITY RATIOS**CAPITAL TURNOVER RATIO**

Working capital turnover ratio shows the number of times the capital has been rotated in the process of carrying on the business efficient use of capital may lead to higher profitability.

Capital turnover ratio=

Net Sales / Capital Employed

**TABLE 9 SHOWING CAPITAL TURNOVER RATIO**

S.NO	YEAR	SALES (in thousands)	CAPITAL EMPLOYED (in thousands)	CAPITAL TURN OVER RATIO
1	2014-2015	75,489.82	47147.84	1.60
2	2015-2016	80,461.87	41869.59	1.92
3	2016-2017	88,983.03	33678.15	2.64
4	2017-2018	93,264.77	30025.05	3.11
5	2018-2019	104,720.68	55585.75	1.88

INTERPRETATION

The above table shows on performance of capital turnover ratio. In 2014-2015, the ratio was 1.06 times, next year in 2015-2016 it increased to 1.92 times and in 2016-2017 it increased to 2.64 times then in 2017-2018 it increased to 3.11 times and in 2018-2019 it decreased to 1.88 times so it shows that the capital turnover ratio has growth and has healthy performance it has very good growth year by year. The capital turnover ratio has high level of performance in 2017-2018 at 3.11 times and lowest level of growth in 2014-2015 at 1.06 times.

FINDINGS RATIO

- The current ratio shows highest level of growth in 2014-2015 at 0.07:1 and lowest level of growth in 2018-2019 at 0.55:1
- The liquid ratio has highest growth in 2014-2015 at 0.37:1 and lowest level of growth in 2015-2016 at 0.31:1.
- The absolute liquid ratio has highest growth in 2014-2015 at 0.18:1 and the lowest level of growth in both 2015-2016 and 2016-2017 at 0.14:1.
- The gross profit ratio has high level of performance in 2015-2016 at 33.01% and lowest growth in 2014-2015 at 28.22%.
- The net profit ratio has high level of performance in 2017-2018 at 6.87% and lowest growth in 2016-2017 at 3.15%.
- The operating profit ratio has high level of performance in 2015-2016 at 18.27% and lowest growth in 2014-2015 at 11.65%.
- The operating ratio has high level of growth in 2014-2015 at 88.35% and low level of performance in 2015-2016 at 81.73%.
- The expenses ratio has high level of growth in 2014-2015 at 87.39% and low level of performance in 2015-2016 at 82.29%.
- The capital turnover ratio has high level of performance in 2017-2018 at 3.11 times and lowest level of growth in 2014-2015 at 1.06 times.

CHANGES IN WORKING CAPITAL

- The changes in working capital for 2014-2015 was 29,147.06 and 2015-2016 was 28,530.11 so, there was decreasing in working capital was 616.95 in 2015-2016.
- The changes in working capital for 2015-2016 was 28,530.11 and 2016-2017 was 36,410.66. So, there was increase in working capital was 7,880.55 in 2016-2017.
- The changes in working capital for 2016-2017 was 36,410.66 and 2017-2018 was 43,691.40 so, there was increase in working capital was 7,280.74 in 2017-2018.
- The changes in working capital for 2017-2018 was 43,691.40 and 2018-2019 was 50,400.48 so there was increase in working capital was 6,709.08 in 2018-2019.

SUGGESTIONS

- As liquidity ratios are not up to their standard level so they need to increase the level of current assets to meet their short-term debts.
- The profitability ratios have average level of performance, so they need to analysis the expenses and cut off expenses to raise profitability level of performance.
- The Capital Turnover Ratio has good performance but to increase their capital earning level, they need to increase their sales turnover.
- The changes in working capital has increasing from 2014-2015 to 2018-2019 but Working capital should be in moderate level, no more decrease and no more increase, for future growth they have to increase cash inflow.

CONCLUSION

The main aim of this study is to analysis overall position of Mahindra and Mahindra company with the help of 5 years (2014-2015 to 2018-2019) and collected data about Mahindra and Mahindra company, used analytical research design and analyzed the financial performance of business is



good. For Future growth, they have to increase the performance level and they should reduce the cash outflow and expenses. Then they will increase their turnover and profit which helps to increase financial performance of business.

REFERENCE

1. **Raja Narayanan and Sandhir Sharma** (2019), "Financial Performance in Maruti Suzuki" *Int.J.Manag.Bus.Res.*, 9(3), 01-07, August 2019.
2. **Suman Rana** (2019), "Financial Analysis of Tata motors and Maruti Suzuki", *Research review international journal of multi disciplinary volume – 04, issue – 03 pp 897 -900.*

WEBSITES

1. <https://www.moneycontrol.com>
2. <https://www.accountingtools.com>
3. <https://www.investopedia.com>



GOOD PARENTING SYNERGY FOR THE CHILD'S CHARACTER DEVELOPMENT: THE ROLE OF WOMEN IN WOLE SOYINKA'S CHILDE INTERNATIONALE

Ajayi, Christianah Olubunmi

Department of Theatre and Media Studies, Bamidele Olumilua University of Education, Science and Technology, Ikere-Ekiti, Ekiti State, Nigeria

ABSTRACT

The instruction from the Holy Scripture says "Train up a child in the way he should go and when he is old, he will not depart from it" (Prov 22:6). This quote makes it mandatory for parents to have a divine partnership with the creator in the training of the child because the harm that the infiltration of cultures, beliefs and traditions are having on the child is more than the good therein. Therefore in considering CHILDE INTERNATIONALE as a case study is to look at the numerous roles the parents has to play in moulding the child's attitudes and bahavious at home and in the society at large. This paper attempts to do a functional analysis of the effects of different parenting styles in the development of the child's character. Attempt is also made to x-ray the different traits that form the personality of a person which will help in understanding the stages of child development through existing literatures. If Wole Soyinka in 1964 recommended paternal discipline as the immediate solution to the problem of socio-cultural and religious pollution caused by the infiltration of foreign culture then one would recommend the joint effort of the woman as a co-pilot with the man in the future journey of the child in this present age of technological development so that the child will not be corrupted but will grow to be appreciating, just, loving and responsible to him/herself, to his/her community and the nation at large because "The child that is not trained will sell the house that is built in the future".

KEY WORDS: *Good Parenting, Synergy, Development, Character, Child.*

INTRODUCTION

Biology is the least of what makes a parent, it goes beyond conception, (Bruce 2005) it is a divine assignment of partnership with God in which training the children in character formation is very essential. Children are society's most critical foundational, back bone that shapes its future progress and that of humanity in general. By considering the utmost importance of a child in the society, this paper will expose us to the prominent role the parents play especially the mother in the character development of the child while focusing on the play text of Wole Soyinka "CHILDE INTERNATIONALE as a case study"

The child as an essential segment of human society is the most valuable natural resource, the childhood shows the man as morning shows the day.

Kundu and Tutoo (2007) thus, the child is the main constituent of any future generation. The minds of children are like wet cement in which in which what we inculcate mainly in the family atmosphere are permanent inscription in their minds throughout their lives either good or bad. Just as we cannot make a dry fish bend, so is in the child unless we bring him/her up in a family atmosphere of good values, culture, tradition and moral especially at the initial stage of life, it will be difficult to mould them at later stages of life and there is no substitution for any family to achieve this, if not done when eve young (David 2010). Thus the family is supreme in the character development of the child with the parents playing a crucial role especially the mother.

According to the Yoruba cosmic view "Iwa" denoting character is the 'Ewa' meaning beauty that



guarantees one a good standing in the society. Thus Iwalewa is a concept that is appraised among the Yoruba people, a concept linked to character, personal virtues, attributes and grit. Another attribute excepted of the child in general is “Omoluabi” cited in Adegboyega (2016) in the 21st Convocation Lecture at the College of Education Ikere Ekiti, by Erelu Bisi Fayemi who describes the notion of Omoluabi thus.

“the Omoluabi is someone who is regarded as having an abundance of respect, humility, compassion, productivity honesty, good manners and all things which makes it possible to relate to various stakeholders in public, private and across divides. In Yoruba we would describe these attributes as “Ofàya” ‘Iwapele’ ‘Irele’ ‘Iteriba’ etc.

To prevent total collapse of moral values and virtues that define a people and check the state of anomie as witnessed today in home and society at large, it is not out of place to have a notion about women and the role they play in the child character development because a Yoruba adage says:

“omo ta o ko, lo ma gbe ile taa ko ta”. Meaning “the child that is not trained will sell the house that is built in the future”

According to (Templar, 2008) the challenges facing parents in the home front in the upbringing of the children are enormous, along the way there are frustrations, anguish, bewilderments and soul searching as we look for the right things to say and do that will set the child on the road to growing up into a happy, well-balanced adult. Luckily, the rewards are huge, the fun, the hugs and closeness. Even the thanks and the pleasure of seeing the child grow into the kind of person you can be proud of. Therefore as a father or mother it is expedient for you to learn some basic facts when it comes to developing character of the child in the atmosphere of discipline, dignity, honor and love.

CONCEPTUAL FRAMEWORK

The child’s character development and its personality formation are the results of the complex interaction of several categories of factors which shall be looked into as basis for proper analysis for the play text.

Good Parenting is the process of caring for the child in an acceptable standard which should be in line with the culture and custom of a given locality cited in Burn and Mutchler (1999). It is the general belief in most part of Nigerian society that there must be discipline, mutual understanding and respect among family members and this should be maintained at all times. For example, one must not address elders or senior people by their names. Among the Yorubas, greeting and the manner of greeting are very important, as a matter of fact failure to greet or answer when greeted is seen as a sign of contention, and failure to greet in the proper way is seen as a sign of disrespect or pride. Such an attitude is immediately scolded by calling to order the person concerned. The concept of training the child is a serious issues that should not be waved aside with the left hand (Sanni 2013) and it is the response to some of these issues that Wole Soyinka decided to use drama to ridicule this kind of undesirable attitude in the lives of present day Nigerian youths.

Ontologically it is the duty of the parent to strategize measures, ways, methods and input extra energy, power to inculcate in the child what its takes to be a responsible citizen. In fact it has been acknowledged that women have a role to play in the nurturing of mother-natures, as the creator has endowed them with a physiology designed to give birth to new life. The adage that says “the hand that rocks the cradle rules the world” cut across cultural boundaries. The “woman” has been and remained a co-pilot with the man in the development indices of the child character development (Adegboyega, 2006).

There are different types and styles of parenting that we have:

- ✓ **Authoritarian:** This type of parenting has clear expectation of how their children should behave; they act like a controlling force, set goals for the entire family. These types of parents also give more importance to social image and family prestige. They do not subscribe to the idea of handling family affair in democratic ways. Above all, this type of parent control the family with some degree of force not loves.
- ✓ **Equalitarian or Authoritative:** These types of parents are democratic in handling family issue and do not take decision in child’s issue erratically.
- ✓ **Permissive:** Parents with this style display some measure of inconsistency in child discipline. They exhibit a nonchalant attitude towards child’s upbringing

**Table Showing the Three Types of Parenting Style**

Style	Parenting Attitude	Effect on Children
Authoritiation	Expect children to follow their rules without deviation	Angry rebels, no independent judgment over dependent.
Permissive	Enforce discipline irregularly (sporadically)	Children may not learn how to keep safe secure and healthy
Authoritative/Equalitarian	Provides children with some freedom but also enforces appropriate limitation and boundaries necessary for safety.	Encourage to develop their own judgment and develop their own interest.

Source: Marrionito Hinacay (2008)

According to Landry, and Smith (2001), the parent is profoundly important to the development of emotional and cognitive growth of a child. A child will learn about relationships with others, morals, self esteem, self-worth and loyalty, all by watching and participating in the family affairs. A family is also the home of the nation and the root of national survival. It is the University of Life and source of human society. The relationships within the family influence the child's character development survival. Therefore, the family is the first socializing institution known to the child. Where the child first learns about right and wrong. Thus, family led by parents has great influence and set the stage for how they grow and develop.

As soon as a baby is born, the parent becomes attached to their child through touching holding, carrying and playing. The world of movement begins and it is the parents who become the first teacher especially the mother. Parents have a much longer and sustained intimate relationship with their children, than anybody else. When they are young, they are learning to identify and label the world, familiarization develops, parents need to understand and learn how they see the world. Parents are natural teachers because they know their child better than anyone else does and they have a better idea of what he/she is ready to learn. Parents should dedicate more time to their children in order to take advantage of the many ordinary events that happen throughout the day in the normal course of family life which are vital to teaching opportunities. As parents, we must provide opportunities for our children to experience the world under our guidance. Children should be able to learn good habits and acceptable societal values that will last a life time.

Several studies on child's development show that the physical presence of parents as well as their concerted efforts is essential to the emotional and overall character development of the child. The parents, especially the mother who is not taking their responsible role or is away most of the time hampers the proper character development of the child, their

demonstration of inconsistent, indiscreet neglecting behaviour mars and spoils the proper growth and development of the child's mental attitudes and social behaviour pattern. Furthermore, young children deprived of parental affection develop emotionally disturbed behaviour and are often seen demonstrating aggression towards their siblings and peers Mead (1934).

Who is this child:- He/she is a young human who is not yet an adult, a person who is strongly influenced by the ideas and attitudes of a particular time and person. As the child develop from infant through teens to adult, they go through series of developmental stages that are important to all aspect of their personality, including physical, intellect, emotional and social. So the proper role of parents is to provide encouragement, support and access to activities that enable the child to master key characters that enables the child develops into a matured and responsible person in the society.

What is character development?

According to Hornby oxford advanced dictionary, character is all the qualities and features that make a person group of people and places different from others. It is strong personal qualities such as the ability to deal with difficult or dangerous situation. On the other hand, development is the gradual growth of something so that it becomes more advanced, stronger etc. it is also an event or stage that is likely to affect what happens in a continuing situation. These definitions stands a solid foundation for the concept of good parenting to fit in properly when it comes to training the child to stand the test of time and situation in the present and the future to come. Furthermore character is defined by McDougall in Jafar (2011) "as the most important in personality in a man that gives or rather is the ground of consistency, firmness self-control power of self direction or autonomy"--- there is also a moral factor, character training and moral training are one and the same thing. Appreciation of



values or ideals such as justice, goodness or truth which is an essential part of each kind of training, if a man knows what is right and what is working, what is valuable and what is trivial, what is good and what is bad, he will be able to form wise judgment and mould a good character. Character is rightly said to be “an accomplished will”.

Character, good or bad is considered to be observable in one's conduct. Thus character is different from value in that values are orientations or dispositions whereas character involves action or activation of knowledge and values, from this perspective values are such as one of the foundations for character (Robert and Fadiman, 2005).

In terms of defining good character, educators stated that this should include developing: (a) moral responsibility and sound ethical and moral behaviour (b) capacity for discipline (c) a moral and ethical sense of the values, goals and process of a free society (d) standards of personal character and ideas which should be seen in any responsible child that has received home training.

According to Campbell and Bond cited in Nayah and Rao (2001) said there are four major questions to be addressed when focusing on character development: (i) what is good character (ii) what causes or prevent it (iii) how can it be measured so that effort at improvement can have corrective feedback (iv) how can it best be developed?

Good character is defined in terms of one's actions. Character development traditionally focused on those traits or values appropriate for the industrial age such as obedience to authority (parents), work ethics, working in group under supervision etc. character development can be influenced by various factors like (1) heredity (2) early childhood experience (3) modeling by important adult and elder youth (4) peer influence (5) the general physical, social environment (6) the communication media (7) what is taught in the school and other institutions and specific situations and roles that elicit corresponding behaviour (Nayah & Rao, 2004).

Actually while schools play a role in the development of character families, communities and society in general also have important influence on the child that is why children that are not properly taught, elicit abnormal behaviours like students indiscipline in schools, students suicide rate will be high, in fact in Nigeria, a students who fails WAEC committed suicide. Is that the solution to his problem or to read hard for another exam? As if that is not enough, crime will be at alarming rate which is even happening in our

society now, burglar issues are numerous, homicide is at an appalling rate, the pregnancy rate of teenage girls is another social problem. Antisocial activities like smoking cocaine, indian hemp and the likes are just the order of the day because children lack good character development due to bad handling from the parents.

SYNOPSIS OF THE PLAY: CHILDE INTERNATIONALE

The play *childe internationale*, written by Nobel Laureate Wole Soyinka was first published in 1987. It appeared first as stage play in 1964 and since then *childe internationale* has been a popular choice for school acting.

The writer brings to the fore a pathetic situation in an African family where the man feels insulted and disturbed as a result of the unruly behaviour of his wife and daughter who have returned from Britain. The daughter has imbibed the western way of life and finds it difficult to come to terms with the indigenous African culture and practice though, this is due to the fact that her mother who is supposed to be the custodian of good nurturing ethnics refused to give her proper home training from the onset and the politician, instead of allowing the situation to get the better of him because of the clash of cultures and ideas that occur between him and the rest of the family demands that he compromise his stand as the head and bread winner of the family, which he is not ready to do; he finally decides to apply (probably as the first and a temporary measure) the traditional method of discipline which is applying a few lashes of the cane to his wife and daughter to bring them back to their senses. Taking into consideration the fact that western civilization has done us both good and bad. The playwright uses “the good” i.e the writing mode to expose some of the “bad” that western civilization has done especially to the young one who have totally relegated the good side. Wole Soyinka is capable of entering not only the world of the adult but also that of the youth and children in order to teach them character and to be able to show case our cultural heritage even outside the country. There is a Yoruba saying that “Tomode ba a da lode ile ni ewo” that if a child is good outside examine his background or home in which he/she comes from.

The play is fun, is a comedy and the writer's satirical humor and skillful use of the English language enable a wider variety of reader to experience the rich details and literary quality that are enjoyed by both young and old, no matter their religious or ethnic backgrounds.



DISCOURSE ANALYSIS OF THE CHARACTERS IN CHILDE INTERNATIONALE

For a reader to appreciate the discourse of the role of parents in the character development of the child, particular attention must be paid to the main characters i.e (the politician, the wife and Titi) in the situation depicted, conflict presented and their final resolutions.

Politician: - He is a typical African man a no-nonsense man, who is highly confrontational

Politician: What is all this about? It is either she was given a report or she was not. Were you given a report?

Titi: Gee Dad you sure are persistent

Politician: Did you get a report? An end of term report? Yes or no, pass or fail

Wife: Oh Kotun, you do keep on so. Don't you realize she "il show it to us when she's ready

Politician: (Flabbergasted) when she is ready

Wife: so don't keep on about it. You'll only aggravate her resistance mechanism

The politician's stance is a direct confrontation with what he feels is out of place as the daughter demonstrates insensitivity to her school reports. While the wife tries to avoid direct confrontation, the politician expressed his emotions loud and clear by shouting for and demanding the daughter's report card, which is the evidence of a term's work at school. The father will not tolerate nonchalant attitude from the daughter but the mother is not helping matters which should not be.

Wife: Oh she is already dating

Politician: Dating? What is that one

Wife: Dating boyfriend. Parties -----

The politician is also surprised that the daughter has a boyfriend which totally goes against the African culture of purity and sanctity for woman before marriage. Girls are expected to keep themselves pure until after traditional marriage. It is believed that a girl going about with boyfriend cannot keep herself pure. This is also part of what the mother suppose to train the child on, she did not and by so doing neglected her role as a mother. The father also got irritated when his daughter announces that her boyfriend is coming to their home for dinner without the permission of the parents. For the daughter to have a boyfriend at that young age of 16 years is disturbing to the father and to say he is coming to their home for dinner without the consent of the parents is disgusting to him.

The Wife: "A been to", who went abroad to study but came back to Nigeria to want to be like the whites and

at the same time want her daughter who went to study abroad to be like the white. She wants the child to throw her indigenous culture away, this makes her child to go 'a -wire' and lacks respect for her culture and for elders. The wife lost her responsibility as a mother to inculcate into her child good character forgetting the fact that "charity begins at home" and that "the child that is not trained will be the one to sell the house that is built".

Titi: But Dad -----

Politician: Oh shut your mouth!

Wife: I've warned you. Don't give this girl a complex

From the excerpt, it shows the kind of woman the wife is. Good parenting can easily be done by both parents infact, especially by the mother but reverse is the case here. The woman as the mentor, the chief instructor should be able to do better. It is the duty of the woman to mould the character of the child with the help of the father. The wife is not persuasive which shouldn't be, children can be daring in such a situation, she is supposed to apply direct confrontation like the politician.

Titi: She is a girl of about 16years of age, she is sent to school in abroad which made her go a-wire, though she has not been properly taught by her mother the rudiment of home training from the on-set. She is a spoilt brat who lacks respect for elders and the culture of the land. She is very lazy and rough, she dislikes going to the class, she hates her teacher and even careless about her report card. She talks a lot without courtesy. Her mother has pampered her so much that she even allow her to date a boy at an early age. She sees her father as an "old fashioned" man who sees nothing good in anything she does. She does not believe in God, infact western culture has done her bad than good.

Titi: (sits and put her feet on a corner of the dining table)

Wife: Don't put your feet on the table

Titi: Oh, I'm tired

(Daddy firmly pushes her feet off the table)

Titi: What did you do that for?

(Put her feet back on the table. Dad stares in disbelief, pushes his food away and turns for solace to his note).

The politician is so frustrated by his daughter's lack of respect for him as a father that he turns to his notes especially since the mother also fails to discipline the daughter at this time. He just cannot believe that only a short period at school in England could snuff out courtesy and home training in his daughter. This is a child who has just returned home from a boarding school, she is expected to greet her



parents properly and show appreciation for the money they spent to send her abroad. She must be reminded to show courtesy when greeting her father and she displays her waywardness by not greeting him properly and later, by putting her feet on the dining table on which her father's food is placed. In African, it is customary for the young person to show courtesy when greeting the elder person, especially in Yoruba land, where girls are expected to kneel down and boys to prostrate. Titi has to be reminded to do that, despite the reminder she refused to greet her father the African way. Instead, she moves near her father and gives a peck on the cheek and this make the politician sad as a father. As a result of his confused state of mind, the politician asks a lot of questions in his attempt to try to understand or bring sanity to the confused situation around him, all but to no avail until he applies the traditional method of discipline (on his wife and daughter) which is caning. Though, he has no intention of disciplining his wife but the conspiracy between the wife and the daughter in lack of discipline makes him discipline the wife, who finally cooperates and then makes the daughter submit to discipline (the application of a few lashes of the cane).

Titi represents present day children and youth in Africa whose social and self consciousness have been totally bastardized and what is regarded as real African values and religious beliefs have been labeled "primitive" and something not worthy of association. Although technological advancement and western education bring good, they also have negative influence on the younger generation in Africa as this has resulted in pride and arrogance on the part of these youths.

UNDERSTANDING THE STAGES OF CHARACTER DEVELOPMENT OF THE CHILD

Our habits, thoughts, attitudes and beliefs, sentiments, goods and ideas, in fact, all that we are and all that we hope and aspire to become constitute our personality. Our taste, our understanding, our enthusiasms and ambitions, our principle of life and conduct etc. colours our personality. They are blended and merged into a unity in such a way that they function as an integrated whole (Jafar, 2007). According to Morton Prince in Jafar, (2007) says personality is the sum of all biological innate disposition, impulses, tendencies, appetite and instincts of the individual and the dispositions and tendencies acquired by experience.

There are about five distinctions of traits in man discovered by Allports and Odbert cited in Jafar (2007).

- **Cardinal Traits:** it is a single trait that dominates most a person's acts. Characteristic or disposition that is so pervasive and outstanding in person's life. This act is traceable to its influence. They are dominant in person's life with ruling passion. They are responsible for making the person famous e.g a person may have on overwhelming need to be powerful, a need for power that can be inferred from virtually all his/her behaviour, such person would not only strive to attain a position of power within the society but would also interact with his partner, his mail carrier, his children and spouse with domination.
- **Central Traits:** Allport term this habit as way of dealing with the world that together dominates a person personality. These are express dispositions that cover a more limited range of situation than is true for cardinal traits. They are the building block of personality which control person's behaviour in a variety of situations, when we describe somebody's behaviour, we are usually referring to central traits such as intelligence, sincerity, kindness, possessive, competitive, honesty etc.
- **Secondary Traits:** it is an often changing traits that often appear as tastes or preferences. They represent dispositions that are less important, less generalized and less often called to describe personality. They refer to one specific attitude or habit. A person might love banana or prefer to spend vacations at home. The traits thus refer to food preferences, clothing habit etc.
- **Common Trait:** This is for basic way of dealing with the world that are seen to some degree in every person. Common traits are categories for classifying group of people on a particular dimension. We might say that some people are more dominant than others. They appear in greater or lesser amount in all man.
- **Personal Disposition:** It is a unique individual ways of responding to the world that cannot be assured by test but only discerned studying the person. It is a trait not shared with others but just personal to the person involved.

These traits or characters should be studied in children to know how to attend to them when it comes to parenting now when we also want to look at it from when the child is in the womb to their teen age, it has different stages also that should be considered (Jafar, 2011).

**Formative Stage (Age 0-5)**

As soon as a baby is born, the parents become attached to the child through touching, holding, carrying and playing. This stage is the entry point where parents no matter where you live or who you are, you stand the chance as a marketer to introduce, inform, influence, instruct and inspire your children to have a clear understanding of your principles, values, beliefs and philosophy about the person you are and that you want them to become. The formative period of building character for posterity starts from the womb where the mother is the queen of that realm and sways a scepter more potent than that of the king. Don't say the child is small and innocent that they don't need training at this level infact you start training them early enough because when they get to 5 years old you have already come too late.

This period is also the stage of INDOCTRINATION

- ✓ When you shout at them at this time, they jerks and if it is done often they grow up to be scare of situations and happenings around them.
- ✓ Don't delegate the child to an house girl or daycare-takers because whatever he/she experience there will be part of what he/she will live with.
- ✓ Don't let the child go out from your care before the age of 6years so that you will be able to exclusively dominate and indoctrinate the child in love. Research by Goldfarb and Spitz (cited in Jafar, 2007) indicated that children institutionalized during infancy who do not experience consistent "mothering becomes apathetic and socially unresponsive. For the adequate character development of the child the role of love is most significant, the amount of affection given to the child during the early years of life seems to be related to the kind of relationship which he can eventually live for with other individuals. It gives him his basic security. Infact being loved permit the child to identify with peers, parents and the culture. Maslow (cited in Jafar 2007) believes that psychological health comes from being loved. The self actualized individual has both the power to love and ability to be loved. A climate of love enables the child to develop more adequate concept of self society and the world.

Repetitive or Registration Stage (Age 6-10)

During this stage, there will be repetitive learning, some of the things that they were taught during age 0-5 may not stick in them so you have to go over it again so that it will now register in them.

- ✓ It is a period where you assure them of their ability, you encourage them that they can make it, if they put more effort into what they are doing.
- ✓ Look for different ways of saying the same thing until it becomes registered
- ✓ They do funny things like being stubborn, difficult to take to correction but don't get tired repeat the process of learning again and again.

Peculiarities about These Stages

- ✓ They tend to copy/imitate; the child at these stages copy parent mannerism, that is why as mother you should be a good role model. What you do matters, it is good to also get them closer to us.
- ✓ Ask the child questions on why they indulge in some attitudes
- ✓ Create time to interact with the child, he/she need our attention more than anyone else.
- ✓ Have a one-on-one discussion with them
- ✓ Listen to them so that they will speak their minds out, let them find friendship in you so that they can show you their broken parts infact the mother is the bank where children deposits their hurts and worries.
- ✓ Don't discuss their secrets with others, it may bring damage to their personality or spoil their relationship with other siblings.

Realization Stage (Age 12 and above)

The child is grown up now, to those things he/she was indoctrinated to

- ✓ He asks questions on why Daddy and Mummy ask him not to do this or do that
- ✓ It is not a stage of commanding, it is a stage of dialoging
- ✓ Reason with the child to get feedback from him
- ✓ Don't scare them away
- ✓ They don't want you to shout at them, at this stage because they believe they are now matured and should be treated as such.
- ✓ They deserve explanation from you so that they will not misbehave

Impression/Definition Stages (Age 13-15)

At this stage, they want to do things themselves, buy clothes, shoes etc themselves

- ❖ They want to impress or define themselves, they want to be the originator of the things they do.
- ❖ They pick their NICKNAMES, abbreviate their names to suit their purpose. They try to make statement with their personality.
- ❖ To them you are "old school" or "old fashion".
- ❖ No more indoctrination but, dialoging, friendship, simulation and deliberate patience
- ❖ Be a little over-looking because they will be daring



- ❖ For you to gain them, you have to be brave
- ❖ They want to try a lot of things but help them to try it safely

Choice Stage (Age 16-18)

Parents and teenager typically don't argue over big issues during this stage, what do they fight about? They squabble about things like teenagers curfew, leisure time activities, clothing and the cleanliness of their room and choice of friends. Parents bickering is the fact that teenagers and their parent define the issue of contention very differently, parent view many issues as matter of right and wrong, not necessarily in a moral sense but as matter of custom and convention teenager in contrast are likely to define these same issue as a matter of personal choice. A mother who disapproves of her daughter's outfit says "people just don't dress that way to go to school. The daughter responds "you wouldn't dress this way for school but I do". They want to control their world during this stage so you need to understand them in (Lawrence 2011).

- ❖ They start to look for heroes to look like. They make fashion after the person they like.
- ❖ They learn from role model, so try to be their best role model
- ❖ To gain them you have to enter their world e.g. football, be a fan too.
- ❖ They want something to explore them take time to study where their interest is or study their influencer.
- ❖ Let them bring their friends home so as to be able to weed the bad ones out.
- ❖ Give them liberty to grow in your presence so that they will not go and imbibe bad character from outside.

General Trips on Good Parenting

- Relax: don't rush to get your children act like adults. They may be noisy, messy. Please take it easy when you want to put things right with them.
- Don't try to do everything: let them learn to fend for themselves. Don't make them learn violin just because you learnt it as a child and loved it. Let them do their thinking for themselves but assist them rightly
- Don't ignore your relationship with your spouse: If you don't want to end up doing this whole parenting stuff on your own. Let your spouse be involved; don't let the children come in between the two of you because in the next 20 years it will be you and your spouse again the way you started.
- Treat your child with respect: simply because they are human and not only that you won't get respect

back from them if you don't show it. Don't just be issuing instructions like eat your lunch, "get into the car" "clean your teeth and so on. You need to add please to make a request. So teach them manners by demonstration or else they will not know how to say "thank you" or "please" to people.

- Enjoy their company: Stop thinking about something else and really concentrate on them, on what they are doing and saying. When your child says "guess what" try to listen to what he/she has to say. The trick to enjoying their company is to focus on it an end in itself.
- See things from their point of view: Children often view the world differently from us, many at times they want to do things their own way let allow them it if is logical. May be they feel like watching a particular programme on TV at a particular time, don't ask them to switch it off without a genuine reason.
- Good parenting involves taking calculated risk: People who don't make mistakes, don't make anything, that means you have to allow them take risk, allow them climb tree, allow them take more subjects in GCE than you think they can handle. They may come home with fractured wrist or poor exam results but they would have learnt a lesson from their mistakes and life goes on.
- Keep your worries to yourselves: What you have to remember is that you are not the only one, your kid worries too. When they want to start school or go for exam, they worry, yours is to reassure them and give them the encouragement to go ahead that all will be well, stop saying "be careful" be careful can start to make a child think something is about to go wrong. You either say have a good time or enjoy yourself.
- Don't have a favourite: under no circumstance should you have a favourite. The children will be looking for hints to discover this and it may cause rivalry between them. Love them equally.
- Find qualities to admire in them: they may be better than you in some aspect. They cannot be like you and they will increasingly want to separate themselves from being like you as they grow older. Embrace it and admire it because your admiration means more to them than almost anyone. Don't nag and don't compare them with anybody (Templar, 2008).
- What you do matters: be a good example to your children. Avoid harsh discipline always try to explain your rules and decision to them so that



they will not see you as a bad person. Diller phyllis say “be nice to your children because they are the ones to choose your rest home” cited in Soetan (2013).

Character development entails so many things especially the parent level of commitment and level of parental activities and participation. Combination of these makes an “involved parents” which is the blue print for family to be effective in their role to ensure greater success for their children.

CONCLUSION

Above all these, parents especially mothers are supposed to fulfill the physical, emotional intellectual and esteem need of the child cited in (Richard, 2010). The children must be brought up in such a way that they will live and grow with tolerance, encouragement fairness, equity, security approval acceptance and friendship. So that they will learn to be patient, confident appreciating, just and loving. On the other hand, if a child lives with hostility criticism, ridicule and shame, they will learn to condemn, be aggressive and feel guilt. As parent we should always be conscious that any dispute or indiscipline between parents, removal of affection of both father and mother from the child is inestimable and non-compensatory. It ultimately hampers the good environment needed for the welfare of our children who are suppose to grow and develop with discipline parental love and affection. Parent should always behave in the best possible way at all times because the best moral compass is the parent’s own behaviour. We are to be a good role model, mentor, monitor, marketer, mender, master, manager, mirror to our children cited in Seotan (2013). Parents are therefore advised to give their children the very best foundation at home which will in turn have a positive impact on the larger society. This is the only way our country could move forward when the family produces God fearing honest, hardworking, responsible and well behaved children, they will in turn contribute positively and effectively to the development of our country.

Recommendations

✓ Parents, educators, affiliates of religious organizations and community member should have an obligation to provide young people with training appropriate to their age level that would assist them in holding to the absolutes that are common across philosophies and beliefs of the major religious traditions, while at the same time helping then clarify and defend their own acquired value.

- ✓ There is need for improved information and awareness about raising family unity through the promotion of positive traditional values and rehabilitation of the role played by women as mothers; one way to promote this is through the introduction of community medal awards to good mothers and families with good children
- ✓ The government should set a programme that will heighten national awareness of the importance of character development in public elementary and secondary schools to the continuing success and stability of Nigerian society.
- ✓ Good counseling and guidance should be provide to help children grow in a normal way with a view to accessing their potentials for their own character development in particular and the nation in general
- ✓ Relevant government agencies especially National Orientation Agency (NOA) and Non Government Agencies should organize from time to time seminars, conferences and lectures in both local and urban areas to enlighten parents more on the best way to raise and nurture children. Even experts in child psychology could be invited or hire to give engaging lectures and expositions to parents. Also feedback from such conferences, seminars and lectures would serve as a starting point for professional and women in academia to investigate.

REFERENCES

1. Adegboyega, A.S. (2006). “Situating the place of the Yoruba woman in nurturing ethnical values” unpublished article Ikere College of Education Pg 4.
2. Bruce, G.E. (2005). “Cognitive psychology” USA published by Thomson Wardworth 122 -125.
3. Burn, J.A. and Mutcher, S.E. (1999). “Race and Ethnic variations in Norms of filial Responsibility among older persons” *Journal of marriage and family* 16, 674-687.
4. David, G.M. (2010). “Psychology” 9th edition New York Worth Publishers.
5. Hornby, A.S. *Oxford advanced learner’s Dictionary of current English* 7th edition New York Oxford university press.
6. Jafar, M. (2007). *Introduction to Psychology. System and theories. Ansan Rd Darya Ganj New Delhi.APH publishing corporation* 68-71.
7. Jafar, M. (2011). *Child psychology. Ansan Rd Darya Ganj new Delhi.APH publishing corporation* 204-210.
8. Kundu, C.L. and Tutoo, D.N. (2007). *Educational psychology. Sterling publishers private limited* 55-56.



9. Landry, S.H., Smith, K.E. et al (2001). "Does early responsive parenting have a special importance for children development" *Journal of Development Psychology* 37, 387-403
10. Lawrence, S. (2011). "Adolescence" 9th edition New York Published by McGraw-Hill 306-307.
11. Marionito, H. (2008). "Talk on parenting styles of pre-scholars" Retrieved from <http://slideshare.net> Accessed on December 4,2017.
12. Mead, G.H. (1934). "Mind, self and society from the stand point of social Behaviour" Chicago university of Chicago press
13. Nayak, A.K. and Rao, V.K. (2004). "Educational psychology New Delhi.APH Publishing Corporation 100-104.
14. Raymond, B.C. (1971). "Abilities, their structures growth and action USA Houghton Milffin Company 12-14
15. Richard, G. (2010). *Psychology the science of mind and behaviour* 6th edition London pt Bembo Mps limited 70.
16. Robert, F. and Fadiman, J. (2005). "Personality and personal Growth" 6th edition, New Jersey Pearson Education limited 16-18.
17. Sanni, S.A. (2013). "Mothers" Nigeria. Children Evangelism production Dept 24-28.
18. Soetan, T. (2013). "Motherhood" Sango Ibadan Trinity House.
19. Soyinka, W.C. (1987). *Childe International Ibadan, Fountain Publication*
20. Templar, Richard. (2008). *The rules of parenting Great Britan Clays Ltd 327 -330.*



CULTURAL GLOBALIZATION AND THE BAULS OF BENGAL

Dr. Susanta Mondal

Assistant Professor in Economics, Bolpur College, Bolpur

ABSTRACT

Globalization is a multifaceted phenomenon that encompasses not only economic but also political, ideological, cultural and other related issues. The interaction between culture and globalization is a matter of contention in the literature and various theoretical approaches have been developed to examine their correlation. Over time cultures get influenced and undergo changes through contact with other cultures. But the process does not always lead to cultural standardization or convergence towards some specific culture. This article provides a short description of the concept of cultural globalization and reviews the primary theoretical approaches related to globalization. It also examines how globalization affects local cultures in the form of external factors. The increasing popularity of the Bauls throughout the world has proved the fact that in the process of cultural globalization the superficial elements of a culture are mixed, but the deeply rooted inherent aspects remain unaffected throughout the process.

KEYWORDS: Baul, Globalization, Culture, Hybridization.

I. INTRODUCTION

Globalization is the prominent determining factor of most of the economic, political and cultural developments of the present world. It is quite commonly used in business and economics implying the opening of local and nationalistic perspectives to a broader interdependent world with free movement of capital goods and services. It has helped the integration of nations of the world with more modern means of transport and economic relations and formation of the global market through multinational corporations. But the term would be matured enough if we apply it to ever more particular aspect of human life. (Robertson, 1991) argued that "Globalization as a concept refers both to the compression of the world and the intensification of consciousness of the world as a whole: both concrete global interdependence and consciousness of the global whole." It has facilitated the expansion of international transactions in cultural matters, such as movies, music, and publications etc. The increasing trade in cultural products is widening

the exposure of all local cultures to foreign cultures and the inevitable consequence of this exposure brings about changes in local cultures, values, and traditions. The term 'Globalization of Culture' was introduced in the late 80's to indicate the situation of convergence of nations and the spread of cultural relations of the people. According to (Giddens, 1990), "the globalization can be defined as the intensification of social relations throughout the world, linking distant localities in such a way that local happenings are formed as a result of events that occur many miles away and vice versa." It refers to the idea that there is now a global common mono-culture transmitted through internet, international tourism etc.

Cultural globalization incorporates the transmission of cultural products across national boundaries and consists of all art form. Changes in musical culture are one of the important aspects of globalization and these changes are complicated and multileveled as they concern institutions, systems of values and social groups involved in musical life. Although many critics believe that exposure of local



culture to international frontier can undermine their own cultural identity, there is no consensus on this matter. Contrary to their views, others see globalization as an essentially equalizing force. (Rothkopf, 1997) argued that globalization promotes integration and removes not only cultural barriers but also many of the negative dimensions of culture.

II. LITERATURE REVIEW

Globalization is a multifaceted phenomenon that encompasses not only economic but also political, ideological, cultural and other related issues (Prasad, 2006). According to (Jaya, 2010) globalization is a natural and inevitable process and no country of the world can ignore or avoid it and failing to embrace it will lead to marginalization. It constitutes a policy or a system that stimulate global interaction, independence and interconnection among different nations through advanced technologies. The concept of culture has two main viewpoints (Hassi and Storti, 2012). In one sense, culture is an integrated set of values, norms and behaviours acquired by human being's as member of a society. In other sense, from sociological perspective it refers to artistic and symbolic creations, heritage and cultural products. (Cowen, 2002) argued that culture refers to some creative products and activities that stimulate and entertain individuals such as music, literature, visual arts and cinema. Researchers have summarized cultural globalization into three main heads: cultural homogenization, cultural heterogenization and cultural glocalization.

However some others views cultural globalization from a more focused perspectives. Yu (2008) stated that cultural globalization is not only a process of homogenization of national culture but the inseparable interconnection among different national cultures as well as the increasing consensus about and consciousness of global issues. (Li, 2002) also hold similar view. Both of them believed that cultural globalization is a process rather than a condition. Contradicting the old left's dubious view about the potential of globalization, (Giddens A. , 2000) argued that globalization does not necessarily imply homogenization of the world controlled by free marketers; rather, it opens an increasing opportunity "for the revival of local cultural identities in different parts of the world ...[creating] new economic and cultural zones within and across nations". Similarly (Tomlinson, 1999) observes a possibility of "self-realization in lifestyles which are themselves open to an expanded mutuality". The present study is in conformity with the view that cultural globalization not

only imply uniformity of national values and beliefs but involves a rather permanent connections among different cultures and in the process of cultural globalization a mutual concern can be achieved through helpful interaction among different cultures.

III. OBJECTIVES

With such a background, the objective of the present study is to analyse cultural globalization with reference to the Bauls of Bengal and the emergence of a shared cross-cultural pattern among modern Baul artists.

IV. INTERACTION BETWEEN CULTURE AND GLOBALIZATION

Interaction between culture and globalization is not a recent phenomenon. With the introduction of urban metropolitan cities and the beginning of commercial activities, dating back to more than 5000 years ago, cultural exchanges have taken place among different societies. But these interactions were limited by the means of communication and transportation. With the industrial revolution, cultural products began to export across borders. From the 19th century cultural industries began to dependent on technical innovations, such as printing in 1860 and electricity and cinema in 1890. In the 20th century cultural transactions are dominated by communication technology and ensure seaming less flow across borders. Interrelationship of culture and globalization has been discussed from various theoretical standpoints. (Hassi & Storti, 2012) grouped them under the three H scenarios: Heterogenization, Homogenization and Hybridization. In the Heterogenization process local culture goes through continuous transformation and reinvention due to global factors. Throughout this process local cultures do not remain unaffected by the global factors, but the main crux of the culture remains unaffected and intact, with only surface change. So Heterogenization refers to the barriers that would prevent to making cultures look alike in such a way that foreign cultural practices remain along with local and national cultures resulting in a side-by-side coexistence of the two cultures (Prasad and Prasad, 2006). But in the homogenization process the forces that prevent to making cultures look alike are weak and with global flows are strong (Ritzer, 2010). According to this view, local culture can be shaped by more powerful global culture to create a new and identifiable class of individual. In this process globalization contributes in the destruction of local culture by eliminating the uniqueness of local culture to establish a homogenized world culture. But (Pieterse,



2004) argued that the idea of cultural homogenization is rather too weak as several local cultures have showed their potential to save their core culture from foreign influences. In between these two opposing view, hybridization process emphasized that globalization is a blend of homogenization and heterogenization that includes both differentiation and interconnection (Robertson R. , 2001). According to this view ‘Global culture’ is a hybrid culture which is neither local nor global at their core. In fact, globalization should not be considered as monolithic network spreading process, rather as a collection of partially overlapping socio-techno-cultural landscapes (Appadurai, 1990). In this sense hybridization is open-ended from theoretical perspective based on practical experience. This view asserts that interaction between globalization and localization is so complex and overlapping that they cannot be understood from the narrow perspective of a centre-periphery-dichotomy (Kumaravadivelu, 2008).

V. IMPACT OF GLOBALIZATION ON LOCAL CULTURE

Globalization is not only a process of increasing the availability of foreign made consumer goods, but also increasing international trade in cultural products such as movies, music and publication. The exposure of national culture to foreign culture often brings change in local culture. It has the potential to enrich the world culturally. The opportunities for cultural exchange brought about can help to promote tolerance and diversity to form a multi-culture “global village” where ideas and practices can be freely exchanged and appreciated. The effects of globalization on cultural diversity are a debatable issue. On one hand it has the potential to mobilize and empower people, provide a means for self-representation and support a collective identity through socialization. On the other has it has the ability to disempower people by misrepresentation, and propel the loss of individualism and group identity. (Jameson, 1998) summaries these two opposing views as : one of a corporate-dominated monoculture where nations and cultural groups alike are deprived of autonomy and identity; and another of a vibrant celebration of pluralism, in which various cultural groups are in direct and harmonious contact with one another, free from limiting political forces.

Globalization can also facilitate to reinforce local culture. For example, in India, satellite TV permits the broadcasting of a number of regional channels which telecast Indian context. This brings an opportunity to Indian individual to identify with his regional ties. Again global companies need to take into

account the cultures of foreign countries in order to expand their operations in different countries. This also enhances cultural awareness. Globalization can also leads to cultural conflict. (Barber, 1992) argued that sometimes violent reaction against the West may be seen by some rebellious group in order to reaffirm their traditional values. They are afraid of change of their traditional culture and want to preserve it.

Globalization can be empowering to various local cultures because it allows self-representation and information sharing on a global level. It allows cultures to have a distinct voice to promote awareness and commentaries on different aspects that are important in preserving the culture and allowing them to retain their diversity. When cultures have control over their public images there is little fear of misrepresentation. Technology and mass media has a major role in revitalizing and restoration of cultural preservation of nations. It preserves the collective identity by giving autonomy and empowerment (Ginsburg, 2002). Therefore, while globalization removes spatiotemporal restrictions on cultural goods and services, it also promotes national desires, identities, dreams and aspirations in the global marketplace.

In spite of having many positive effects, cultural globalization has had some negative impacts on cultural diversity. Multinational corporations can promote consumer culture influencing societal values. There is also the fear of loss of individualism and group identity. Globalization promotes further colonization that impacts intellectual property and cultural rights.

VI. BAULS OF BENGAL

There has been much disagreement over the meaning and origin of the term ‘Baul’ (Hindi variant ‘Baur’). It may have been derived from Sanskrit word ‘*Vatula*’ (affected by wind-disease i.e, crazy) or from ‘*vyakula*’ (impatiently eager). Other opinions states that it derives from the Arabic word ‘*awliya*’ (plural of ‘wali’ meaning ‘near’ or ‘devotee’) or from sahaajiya Buddhist word ‘*bajrakul*’ subsequently became ‘bajul’ and then ‘baul’ (Mondal, 2015). All these terms are consistent with the apparent life style of the Bauls which refers to a group of inspired mystics with an eagerness for spiritual life that is free from religious shackles (Dasgupta, 1994). The Bauls belong to the socio-economically and politico-religiously marginalized section of West Bengal, north-eastern India and in Bangladesh. The baul philosophy was influenced by three religious customs: *Sahaajiya* (Buddhism), *Bhakti* (Hindu *Vaishnavism*) and *Sufi* (Islamic). They are primarily minstrels, comprised partly of householders



and mainly of wandering mendicants. Many of them live in *akhra* (place of sharing their view, songs and philosophy with others) and are dependent on *madhukari* (subsistence earning refusing any surplus) with a small number having alternative professions. From historical perspective, exclusion politics of *Brahmins* (upper caste Hindu) and Muslims and colonial oppression created social and economic uncertainty among the lower rung of the society, which paved the way for the emergence of many 'deviant sects' like *Baul*, *Fakir*, *sain* etc. (Urban, 2001). Subsequently, these sects questioned and challenged the religious dominance of the so called social rulers through their esoteric, overturn and critical discourses, expressed through codes in their songs.

Though bauls have been originated from different religious sects but they strongly deny the external religious practices and strongly criticize the caste system, injustice and socio-economic inequality (Sengupta, 2015). Through their song they try to unshackle the intolerances and inequalities by fulfilling a dream of an alternative, less-exploitative, more egalitarian spiritual and social order (Urban, 2001). Sometimes they rely on their evocative and esoteric songs in order to express and to seek some kind of deeper spiritual solution to these economic ills. Baul songs are spiritual and philosophical in nature and are divided into different *tattwa* (theory of epistemology) such as '*prema-tattwa*' (spiritual love), '*guru-tattwa*', (spiritual teacher), '*deha-tattwa*' (body), '*param-tattwa*' (supreme or almighty), '*srishti-tattwa*' (creation), '*manasiksha*' (self-realization), '*gujhyo-tattwa*' (esoteric) (Sengupta, 2015). Sometimes socio-economic issues like poverty, inequality and injustice occupies a place as theme in their songs. The Baul songs have passed from one generation to another orally without records. But presently, many Bauls records their song in electronic media.

The partition of Bengal in 1905 by British government created a massive tension in the co-existence of Hindu and Muslims. Some sensitive Bengalis like Mohammad Mansur Uddin tried to re establish the co-existence between the two communities in the past for continued co-operation in future. He published a book entitled *Haramoni* or *Lost Gems* which was basically a collection of Baul songs. The intrinsic philosophy of Baul is so strong that great poet Rabindranath Tagore was deeply impressed by this folk music that are reflected in his many poetry and songs. Some of his songs are centered on 'Moner Manush' indicating a constant dialogue that take place between man/woman and the Almighty. Kshitimohan

Sen, a friend and coeague of Tagore, in his book *Hindu-Muslim co-operation in India* praised Bauls as paragons of communal co-operation (Capwell, 1988). Recognizing the rich cultural heritage UNESCO has designated the works of Baul as "Masterpieces of oral and intangible heritage of humanity" in 2005.

Baul music is carried out by some musical instruments like the Ektara, the Dotara, the Dhol, Manjiras etc. These instruments are made from some simple natural materials like, clay, bamboo, wood etc. which generate sweet melodious tunes. The chanting sound cannot be matched by modern musical instruments. There are audiences who still appreciate the baul song in its original form and acknowledge the deeper meaning of the song. But today many musicians introduced modern touches into the traditional form to attract audiences. Traditional Bauls believed that it would be a destruction of tradition to modify the words and the intrinsic meaning of the song, except changing the rhythm to attract the modern audiences. The resurgence of many such events has proved that the baul music tradition has preserved and spreaded globally with the help of advanced electronic media. In fact only the superficial elements of a culture are mixed, but the deeply rooted inherent aspects remain unaffected throughout the process. It is only the peripheral elements of the culture that crosses nation boundaries through cuisine, shopping habits, arts and entertainment. Nevertheless deep core elements remain adjacent to the native culture (Hassi & Storti (2012).

VII. BAULS IN THE GLOBALIZED ERA

Under cultural globalization, the exposure of local artists to new systems of socio-cultural system is inevitable. It may bring about many undesirable consequences. The apathetic attitude of the urban India towards folk cultures is likely to pervade to the rural areas as the latter is exposed to the infiltration of electronic media. Lack of interest among younger generation to acquire the skills of rural folk culture is a dismal sign. The electronic media is detaching rural audiences from the auspices of traditional forms with the 'marginalization' of rural artists by the dominance of metropolitan cultural forms under the liberal regime in post modernized India (Soja, 2000). In this sense globalization is actually restricting the area of an individual artist's own creativity. Presently, local artists are striving against a powerful technology driven modern culture while struggling for its own cultural survival. (Gramsci, 1971) noted that "the history of subaltern groups is necessarily fragmented and episodic. There undoubtedly does exist a tendency to



(at least provisional stage of) unification of historical activities of these groups, but this tendency is continually interrupted by the activity of the ruling groups; ...Subaltern groups are always subject to the activity of ruling groups, even when they rebel and rise up....”

Globalization may also be an opportunity for the rural artists to absorb new themes and formulate new cultural strategies to attract greater audience. With the advancement of communication technology, the Bauls and their songs has come into the reach of urban audience of India and abroad. By virtue of their message, rhythm and mode of representation, they have created a discernible attraction throughout the world. They have added special attractive features in their mode of presentation along with the inclusion of modern musical instruments to get attraction from all classes of audience. They are now invited to stage their performance in different western countries (Mondal, 2015). All these incidents have certainly brought about changes in the Baul community that goes both in favour and against them. Bauls, who once lived in *Ashramas* and *Akhdras*, now started settling down in the urban areas with their families. Some of them are now more interested in recording their songs in electronic media. This individualistic attempt for the upliftment of their materialistic status compels them to embrace a different lifestyle different from their *sadhana*. Their attachment with the globalized world has expanded their activities as well as greater interaction with the *non-bauls*.

In spite of all these abominable consequences, there are still some cultural traits of their own that maintain their social and cultural identity in the secular society. The Baul singers still maintain their tradition, dressed in saffron gowns and plunking one-stringed instrument *ektara*, singing in trains, at village roads and marketplaces. Following the practice of *madhukari* they make regular contact with their followers in local communities and accept any offerings as per the ability and choice of their admirers. This helps them to reduce their ego and ensures the sustainability of their spiritual journey. Their reliance and confidence on local patronage help them to retain their discourses, values and ideology out of the reach of mainstream religious and socio-political institutions (Dutta, 2019). They are very much conscious about preserving their mystical identity and maintain a balance between sexo-yogic representation and introduction of modern elements in their songs. They are keen to identify themselves as ‘Real Baul’ even in the midst of change in the competitive environment. They have shown greater

competence in handling modern musical instruments by adopting new melodies, tunes in spite of embracing the traditional format. Overall, they have adopted a hybridization attitude to meet the changing scenario of a globalized world along with maintaining their own cultural identities.

VIII. CONCLUSION

The interaction between culture and globalization is a matter of contention in the literature and various theoretical approaches have been developed to examine their correlation. Over time cultures get influenced and undergo changes through contact with other cultures. But the process does not always lead to cultural standardization or convergence towards some specific culture such as American and European one. There are ample empirical evidences which show that globalization preserves national cultural diversity in the cultural integration process. In order to get benefit from world culture, local culture should not shut them off from the rest of the world, rather should open up to improve their own capabilities. In the era of globalization, we have access to an immense source of information which influences our socialization through acquired knowledge. These earned qualities are not always destructive to the core components of the native culture. Societies should adapt these practices according to the specification of their local culture. Several academicians and Baul performers believe that on the basis on their intrinsic philosophy and paths they can provide hope for the increasingly insane and turbulent world. By talking the global issues from their local spaces, they open up new avenues for local global exchanges. Breaking the boundaries of caste, class and religion, the Bauls are trying to establish a humane society devoid of exclusion, oppression and material-scarcities. Despite bitter memories of partition and a succession of communal riots in both east and west Bengal, the reputation and popularity of the Baul singers still cuts across borders and religious differences.

BIBLIOGRAPHY

1. Appadurai, A. (1990). *Disjuncture and Difference in the Global Cultural economy*. *Public Culture* 2 (2), 1-24.
2. Barber, B. (1992). *Jihad vs. Mc World*. *The atlantic monthly* 269 (3), 53-65.
3. Capwell, C. (1988). *The Popular Expression of Religious Syncretism: The Bauls of Bengal as Apostles of brotherhood*. *Popular music* 7(2) *The West asia/West Crossover*, 123-132.



4. Cowen, T. (2002). *Creative Destruction: How Globalization is Changing the World's cultures*. Princeton, New Jersey: Princeton university Press.
5. Dasgupta, A. (1994). *The Bauls and their Heretic Tradition*. *Social scientist*, 22 (5-6) , 70-83.
6. Dutta, U. a. (2019). *Songs of the bauls: Voices from the margins as Transformative Infrastructures*. *Religions* 10(5), Article 335 .
7. Giddens, A. (2000). *Runway world: How Globalization is Reshaping Our Lives*. New York: Routledge.
8. Giddens, A. (1990). *The Cosequences of Modernity*. Stanford: Stanford University Press.
9. Ginsburg, F. (2002). *Screen Memories: Resignifying the Traditional in Indigenous Media*. In L. A.-L. F. Ginsburg, *Media worlds: Anthropology on a New Terrain* (pp. 39-57). Berkeley: University of California Press.
10. Gramsci, A. (1971). *Selections from the Prison Notebooks of Gramsci*. New York: International Publishers.
11. Hassi, A. and Storti (2012). *Globalization and Culture: The Three H Scenerio*. In H. C.-M. (ed.), *Globalization -Approaches to Diversity*. Intechopen.
12. Jameson, F. (1998). *Globalization as a Philosophical issue*. In F. J. (eds.), *The Cultures of Globalization* (pp. 54-77). London: Duke university Press.
13. Jaya, J. M. (2010). *Globalization or Americanization: Implications for Sub-Saharan Africa*. In K. D. (ed.), *Globalization- Today, Tomorrow* (pp. 113-24). Rijeka, Croatia: Sciyo.
14. Kumaravadivelu, B. (2008). *Cultural globalization and language Education*. New Haven, CT: Yale university Press.
15. Li, Z. (2002). *Cultural Globalization and the Reconstruction of Modern Chinese culture*. *Nankai university journal* 5 (4) , 23-38.
16. Mondal, B. (2015). *The Role of Media in Popularising Indian Baul Culture and their Songs to the World*. *Journal of Content, Community and Communications* 1(1) , 30-34.
17. Pieterse, J. N. (2004). *Globalization and culture*. Lanham, MD: Rowman & Littlefield Publishers.
18. Prasad, A. a. (2006). *Global Transitions: The emerging New World Order and its Implication for Business and management*. *Business renaissance Quarterly*, 1 (3) , 91-113.
19. Ritzer, G. (2010). *Globalization: A Basic text*. West Sussex, UK: Wiley-Blackwell.
20. Robertson, R. (2001). *Globalization theory 2000+: major Problematcs*. In G. r. (eds.), *Handbook of Social Theory* (pp. 458-71). London: Sage Publications.
21. Robertson, R. (1991). *THE Globalization Paradigm: Thinking Globally*. In D. B. (ed.), *Religion and social order* (pp. 207-24). Greenwich CT: JAI Press.
22. Rothkopf, D. (1997). *In Praise of Cutural Imperialism? Foreign policy*, no. 107 (Summer) , 38-53.
23. Sengupta, J. (2015). *The Baul Sursadhak: the Tradition and Individual Talent*. *Journal of Literature and Art Studies* 5 , 151-57.
24. Soja, E. (2000). *Postmetropolies: critical studies of Cities and Regions*. Oxford: Blackwell Publishers.
25. Tomlinson, J. (1999). *Globalization and culture*. Chicago: University of chicao press.
26. Urban, H. (2001). *The Marketplace and the temple: Economic Methaphors and religious Meanings in the Folk Songs of Colonial Bengal*. *The Journal of Asian Studies* 60 , 1085-1114.



DEVELOPMENT AND EVALUATION OF ANALGESIC PEDIATRIC FORMULATIONS- IBUPROFEN EFFERVESCENT GRANULES

K.Sandeep

Vikas college of Pharmacy, Vissanapeta, Krishna-521215, A.P.

ABSTRACT

Objectives: The aim of the present investigation is to prepare the effervescent granules of different formulations and evaluated for different parameters including drug release study.

Methods: The effervescent granules of five different formulations such as F1, F2, F3, F4, and F5 were prepared by the wet granulation method using different concentration of excipients including sodium bicarbonate and potassium bicarbonate. The prepared formulations were evaluated for different parameters including effervescent time as well as drug release study.

Results: After evaluating all the parameters, it has been found that the formulation F5 shows better drug release among all the formulation and least effervescent time. Where it can conclude that as the effervescent time is less, i.e., it quickly bursts and shows its effect quickly. Lesser the bursting time quicker the drug release.

KEYWORDS: Ibuprofen, Nonsteroidal anti-inflammatory drugs, Osteoarthritis, Acid neutralizer, Effervescence, Effervescent granules.

INTRODUCTION

Granules are a type of dosage form and composed of dry aggregates of powder particles that may contain one or more APIs, with or without other ingredients. Granules are frequently compacted into tablets or filled into capsules, with or without additional ingredients. Effervescence is the escape of gas from an aqueous solution and the foaming or fizzing those results in the release [1-3]. Effervescent granules are a combination of citric acid and tartaric acid, and when they come in contact in water, it causes effervescence of CO₂. This CO₂ helps as an excess acid neutralizer and taste masker. It also makes the drug more soluble. Effervescent granules are popular delivery systems due to their fast dissolving, highly soluble, and stable nature. Nowadays, many pharmaceutical products such as antacids, analgesics, and cough/cold are dispensed as effervescent granules. The dosage form is dissolved or dispersed in water to initiate the effervescence before ingestion [4-7]. The advantages of effervescent granules are easy to administer, onset of action is faster, easily portable, gentle on the digestive tract, it is better tasting, and more stable than liquid dosage form. With advantages, there have some disadvantages also these are – cannot be given to the children due to the possibility of gas (CO₂) toxicity. If the packaging is not done properly, then there are chances of degradation by environmental moisture. It has a shorter shelf life as compared to other solid dosage forms. Ibuprofen is chemically [(+/-) 2-(p-isobutyl phenyl) propanoic acid

(CH₃)₂CHCH₂-C₆H₄CH₂CO₂H] and is well known as nonsteroidal anti-inflammatory drugs, analgesic and antipyretic agent. It is a weakly acidic drug having high permeability through the stomach. The aim of the present investigation is to formulate five different formulations of ibuprofen with varying the concentration of excipients and evaluate for different parameters and select the best formulation among the prepared formulation and also determine the effect of polymers [8-10].

MATERIALS AND METHODS

MATERIALS

Ibuprofen was procured by Alkem Pvt. Ltd.; citric acid, sodium bicarbonate, methanol, and cross-povidone were gifted by Merck Life Science Limited; and tartaric acid, potassium bicarbonate, mannitol, croscarmellose, lactose, and hydroxypropyl methylcellulose (HPMC) were gifted by Qualigens Fine Chemicals. In addition, an electronic balance (Shimadzu), a hot air oven (Labhosp), and ultraviolet (UV) chamber were used in this study.

METHODS

Preformulation studies

The preformulation study is a branch of pharmaceutical sciences that use for the determination of physicochemical properties of a drug substance and other excipients used in the formulation. The goal of preformulation studies is to choose the correct form of the substance, evaluate its physical properties, and generate a thorough understanding of the material's stability. The use of



preformulation parameters maximizes the chances in formulating an acceptable, safe, efficacious, and stable product. Preformulation studies encompass of organoleptic properties (color, odor, and taste), solubility studies (data are shown in Table 1), assay, melting point, determination of lambda max, preparation of calibration curve, and Fourier transform infrared (FTIR) studies (data are shown in Table 2 and Fig. 1).

Preparation of effervescent granules

The effervescent granules were prepared by the wet granulation method. All the ingredients were weighted properly. All the ingredients were powdered and sieved to get a proper uniform particle size. A clean china dish was taken and all the solid ingredients were transferred to it one by one. Add the solvent in proportions until a coherent mass was formed of uniform consistency. The coherent mass was dried at 30–40°C and then sieved through sieve no.16. The required quantity for different formula is given in Table 3.

Angle of repose

The prepared granules were allowed to pass through a funnel and the height of the pile (h) and radius of the pile (r) are measured [11]. From this, the angle of repose, i.e., the angle between the height of the pile and radius of the pile is calculated with the help of the following formula.

$$\text{Angle of repose } \Theta = \tan^{-1}(h/r)$$

Bulk Density [11]

A certain weight of granules was taken in a 100 ml measuring cylinder without compacting and maintain the proper level of granules and measure the volume, V_o (bulk volume) and calculated according to the formula given below.

$$\text{Bulk density} = \text{Weight of powder taken/Bulk volume} \quad (2)$$

Tapped density

A certain weight of powder was taken in a 100 ml measuring cylinder and tapped for 100 times. The volume of the granules was measured after complete tapped and got tapped volume [11]. Calculate the tapped density according to the following formula:

$$\text{Tapped density} = \text{Weight of granules/Tapped volume} \quad (3)$$

Carr's index ratio [12]

This was determined using bulk density and tapped density using the formula mention below.

$$\text{Carr's index ratio} = \left[\frac{\text{Tapped density} - \text{Bulk density}}{\text{Tapped density}} \right] \times 100 \quad (4)$$

Hausner's ratio

Hausner ratio is used to determine the flow property of powder [12]. Lower the Hausner ratio betters the flow property or vice versa. This

Table 1: Solubility data of ibuprofen

Solvent	Solubility
Water	Poorly soluble
Phosphate buffer 6.8	Slightly soluble
Phosphate buffer 7.2	Slightly soluble
Phosphate buffer 7.4	Slightly soluble
Methanol	Soluble

*Solubility of drug was performed in both polar and non-polar solvent

Table 2: Infrared study of ibuprofen (functional groups with its respective wavenumber)

Functional group	Wave no. (Cm ⁻¹)
C=O	1510.00
C-H	3184.40
(C-H) CH ₂	3044.39
C=O	1707.00
O-H	2988.29

*The unit of wavenumber is cm⁻¹, No. indicates number was calculated from bulk density and tapped density using the formula given below.

$$\text{Hausner's Ratio} = \text{Tapped density/Bulk density} \quad (5)$$

Effervescence time

In vitro, effervescent time is determined by taking a specific amount of the formulation and added to 150 ml of water and the effervescence time was determined [12,13]. Repeat the procedure for all the prepared formulations and measured the effervescent time for all the batches.

In vitro drug release study

The dissolution studies were done to determine the amount of drug released during a specific period of time using USP type I dissolution apparatus (basket type) [12,14].

At first, 900 ml of dissolution medium (0.1 N HCl) was placed in the dissolution vessel. The granules were put inside the basket and the basket was covered with a clean and dried muslin cloth. The RPM was set at 100/min. About 5 ml of the sample was collected at an interval of 2 min and 5 ml of fresh dissolution medium was replaced in the dissolution basket. Thus, the sample collected at specified time intervals of 2, 4, 6, 8, and 10 min was subjected to UV analysis at a wavelength of 221 nm.

RESULTS AND DISCUSSION

After observing the organoleptic properties of effervescent granules containing ibuprofen drug was found to be white, slightly odor, tasteless, and crystalline in their properties. Drug ibuprofen is poorly soluble in a polar solvent and soluble in a non-polar solvent. Solubility data are given in Table 1. The melting point was found to be 75°C.

In FTIR study, the functional groups and wavenumbers shown by the drug ibuprofen are given in



Table 2. This indicates that the drug ibuprofen shows a proper peak of C=O stretch at 1707.00/cm, O-H stretch at 2988.29/cm, (C-H) CH₂ stretch at 3044.39/cm, and C-H stretch at 3184.40/cm; hence, it can conclude that the drug is pure (infrared spectra shown in Fig. 1).

The effervescent granules of five different formulations (F1, F2, F3, F4, and F5) were prepared by the wet granulation method by varying the concentration of ingredients. The detail compositions are given in Table 3. In

these compositions, concentrations of polymers mainly potassium bicarbonate, croscarmellose, cross-povidone, and HPMC were changed and observed the data for different parameters. These polymers have an important role in bursting time as well as for drug release properties.

The prepared formulations were evaluated for flow property. Flow property is a very important factor for granules formulation. Proper

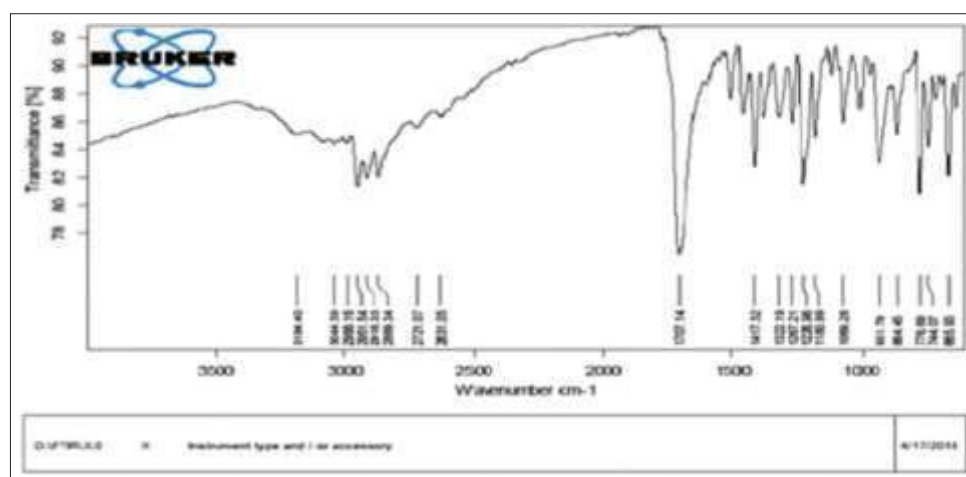

Fig. 1: Fourier transform infrared spectra of ibuprofen

Table 3: Composition of formulations

S. No.	Ingredient	Formulations				
		F1	F2	F3	F4	F5
1.	Ibuprofen	0.25 g	0.25 g	0.25 g	0.25 g	0.25 g
2.	Citric acid	1.00 g	1.00 g	1.00 g	1.00 g	1.00 g
3.	Tartaric acid	2.00 g	2.00 g	2.00 g	2.00 g	2.00 g
4.	Sodium bicarbonate	3.00 g	3.00 g	3.00 g	1.50 g	3.00 g
5.	Potassium bicarbonate	-	-	-	1.50 g	-
6.	Croscarmellose	1.00 g	2.00 g	-	1.00 g	1.00 g
7.	Cross-povidone	1.00 g	-	2.00 g	1.00 g	1.00 g
8.	Hydroxypropyl methylcellulose	0.50 g	0.50 g	0.50 g	0.50 g	1.00 g
9.	Mannitol	0.25 g	0.25 g	0.20 g	0.25 g	0.50 g
10.	Lactose	1.00 g	1.00 g	1.00 g	1.00 g	1.00 g
11.	Methanol	2-3 ml	2-3 ml	2-3 ml	2-3 ml	2-3 ml

*The weights of ingredients are in g except methanol, methanol is in ml

**Table 4: Flow properties of formulations**

Formulation	Angle of repose	Bulk density (g/cm ³)	Tapped density (g/cm ³)	Carr's index	Hausner's ratio
F1	28.30	0.55	0.66	16.60	1.20
F2	29.12	0.53	0.61	13.11	1.15
F3	27.68	0.57	0.67	14.92	1.17
F4	28.03	0.54	0.63	14.20	1.17
F5	27.60	0.56	0.65	13.80	1.16

Table 5: Effervescent time of formulations

Formulation	Effervescent time (min)
F1	1.22
F2	1.19
F3	1.11
F4	1.15
F5	1.09

*Bursting time is observed in minutes

Table 6: Percentage cumulative drug release study

Time (min)	% CDR of formulation				
	F1	F2	F3	F4	F5
0	0	0	0	0	0
2	11.46	14.08	35.90	34.50	32.44
4	12.91	17.34	30.59	36.64	36.14
6	15.02	19.53	67.79	66.33	67.87
8	15.56	23.67	68.05	68.65	69.29
10	16.72	31.81	71.65	69.63	79.50

*CDR: Cumulative drug release

Flow of granules gives a good release of drug from the formulations. Among all the prepared formulations, formulation F5 shows good flow property. All the data for the flow properties of all the formulations are shown in Table 4.

Effervescent time for effervescent granules was a very essential parameter for measuring the bursting time and also for the drug release parameter. For a good effervescent formulation, bursting time should be less, i.e., the granules should quickly evolve the bubbles of gas in a liquid. Among all the five formulations, F5 shows less effervescent time. All the data for an effervescent time are shown in Table 5 (Fig. 2).

In vitro drug release study was performed for all the prepared five formulations in 0.1 N HCl as dissolution media using USP type I dissolution apparatus (basket type). The dissolution studies were carried for 10 min for all five formulations. Among all the formulations, formulation F5 shows the highest drug release, i.e. up to 80%. All the data are summarized in Table 6. and graphical representation were shown in Fig. 3.

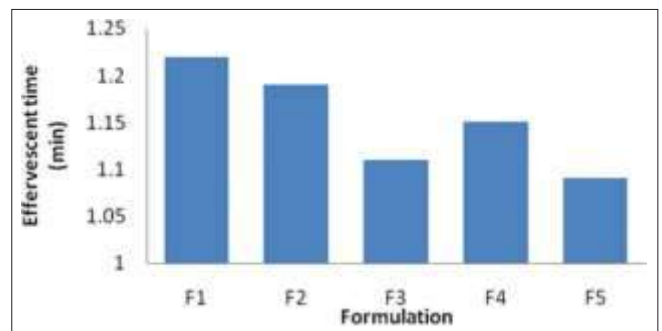
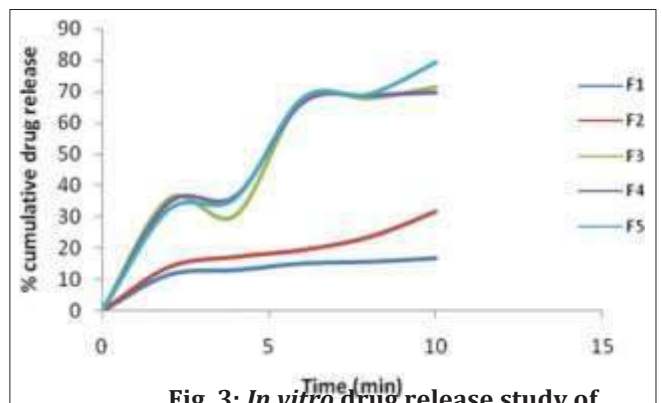
**Fig. 2: Effervescent time (min) of different formulations****Fig. 3: In vitro drug release study of formulations**

CONCLUSION

The present investigation of ibuprofen effervescence granules was prepared successfully by wet granulation method using a different concentration of polymers. After the preparation of five different formulations such as F1, F2, F3, F4, and F5 was evaluated for preformulation studies, formulation study, and *in vitro* evaluation study. Among all the five formulations, F5 formulation shows good results. After performing the entire test, it can be concluded that formulation F5 containing all the ingredients except potassium bicarbonate shows satisfactory result and it can be used for further study.



AUTHORS' CONTRIBUTIONS

We herewith submit a manuscript entitled: "Preparation and evaluation of ibuprofen effervescent granules".

We hereby declare that the manuscript is not submitted or being considered to another journal in part of full for publication. The authors listed above are involved in the carrying out research work presented in the manuscript and that the research work was carried out at the address(es) listed in the title page of manuscript.

CONFLICTS OF INTEREST

The author(s) declare(s) that there are no conflicts of interest.

REFERENCES

1. Patel SK, Kumar D, Waghmode AP, Dhabale AS. Solubility enhancement of ibuprofen using hydrotropic agents. *Int J Pharm Life Sci* 2011;2:542-5.
2. Srinath KR, Chowdary CP, Palanisamy P, Vamsy KA, Aparna S, Ali SS,
3. et al. Preparation and evaluation of effervescent tablets of paracetamol. *Int J Pharm Res Dev* 2011;3:76-104.
4. Saibaba, S.V.; Kumar, M.S.; Ramu, B. Pharmaceutical impurities and their characterization. *European J Pharm Med Res* 2016, 3(5), 190-196.
5. S Gopalakrishnan, A Chenthilnathan. Formulation and In Vitro evaluation of Aceclofenac oral floating tablets. *Research J. Pharm. and Tech.* 4(4): April 2011; Page 642-645.
6. Bandameedi R, Pandiyan PS. Formulation and evaluation of gastro retentive floating bioadhesive tablets of hydrochlorothiazide. *Asian J Pharm Clin Res* 2017;10:150-5.
7. Addanki Gopikrishna, B. Ramu, G. Srikanth, Dr. Bigala Rajkamal (2016). Formulation of isoniazide sustained release formulation by using carbopol 934 P P. *Int J App Pharm Sci Res.* 1(2):60- 69. Doi: 10.21477/ijapsr.v1i2.10177.
8. Maghrabi IA. Formulation of effervescent ibuprofen. *Int J Pharm Sci Rev Res* 2017;43:194-9.
9. Shet N, Vaidya I, Banerjee N. Formulation and evaluation of aceclofenac sodium effervescent taste masked granules. *Int J Bio Pharm* 2014;5:50-8.
10. Palanisamy P, Rabi A, Kumar DY. Formulation and evaluation of effervescent tablets of aceclofenac. *Int Res J Pharm* 2011;2:185-190.
11. Aslani A, Jahangiri H. Formulation, characterization and physicochemical evaluation of ranitidine effervescent tablets. *Adv Pharm Bull* 2013;3:315-22.
12. Thulluru A, Kumar VS, Kumar MP, Roshitha B. Effect of effervescence in combination with superdisintegrants in the formulation of propranolol HCl oral disintegrating tablets. *Asian J Pharm Clin Res* 2017;10:227-34.
13. Diyya AS, Thomas NV. Formulation and evaluation of metronidazole effervescent granules. *Int J Pharm Sci Res* 2018;9:2525-9.
14. Singh SK, Sharma V, Pathak K. Formulation and evaluation of taste masked rapid release tablets of sumatriptan succinate. *Int J Pharm Pharm Sci* 2012;4:168-74.
15. Mali AD, Bathe RS. Development and evaluation of gastro retentive floating tablets of a Quinapril HCL by direct compression technique. *Int J Pharm Pharm Sci* 2017;9:36-45.



A STUDY ON IMPACT OF CELEBRITY ADVERTISEMENTS IN SALES PROMOTION OF RELIANCE TRENDS WITH SPECIAL REFERENCE TO COIMBATORE CITY

Dr. M. Kalimuthu

*Assistant Professor, Department of Commerce with Professional Accounting,
Dr.N.G.P Arts and Science College, Coimbatore*

Miss. Vidyasri. V

*III. B.Com (PA), Department of Commerce with Professional Accounting,
Dr.N.G.P Arts and Science College, Coimbatore*

ABSTARCT

This study was undertaken to examine the impact of celebrity advertisements in the sales promotion of Reliance Trends. Based on the results of the research, it is understood that the celebrity Advertisements gives a positive impact on the sales promotion. The study encloses that the office going women are more interested to purchase in reliance trends. The second most influencing factor of Reliance trends is their high quality of the fabric and also their discounts and offers. The changing life of the consumers the impact of celebrity advertisements definitely have positive impact in the sales promotion.

KEYWORDS: *Celebrity Advertisements, Quality, sales promotion*

INTRODUCTION AND DESIGN OF THE STUDY

Advertising is a marketing communication that employs an openly sponsored, non-personal message to promote or sell a product, service or idea. Sponsors of advertising are typically businesses wishing to promote their products or services. Advertising is differentiated from public relations in that an advertiser pays for and has control over the message. It differs from personal selling in which the message is non-personal. Celebrity endorsers enjoy high popularity among the brand managers. Each year, companies spend vast amounts of money to convince celebrities to endorse their products and brands for instance; in India approximately 45 percent of televised commercials feature celebrities; in us, approximately 25 percent of all advertising employ the celebrity endorsers.

STATEMENT OF THE PROBLEM

Reliance trends is one of the fastest growing textile show room in Coimbatore city, it has

various branches in Coimbatore. They give a tough competition in the market. The celebrity influence advertisement plays a major role in buying behavior of the people. The people may be influenced by the advertisement to buy the product. If their favorite celebrity is missing they might not buy that product. So this study helps to know about the sales promotion with the help of celebrity advertisement.

OBJECTIVES

- To understand the influence of the celebrity on purchasing decision of the customer.
- To study about the availability of products that are shown in the advertisements of Reliance Trends.
- To study on satisfaction level of customer towards celebrity advertisement.
- To identify whether the celebrity advertisement results in increase in sales of Reliance Trends.

**RESEARCH METHODOLOGY**

The following methodology is used for the study.

1. SOURCE OF DATA

The study includes both primary and secondary data.

- The primary data have been collected from the target respondents through structured questionnaire.
- Secondary data have been collected from different sources such as journal, book and internet.

2. SAMPLE SIZE

The study focused on primary data from 110 respondents.

3. SAMPLE METHOD

Sampling is the selection of some part of an aggregate or totality on the basis of which it is made. Convenient sampling is used this research

4. TOOLS USED

The statistical tools used for analysis are,

1. Simple Percentage method.
2. Likert scale
3. Rank analysis

- The details given by the respondents are considered as true and the study results are based on assumption.

REVIEW OF LITERATURE

Ankita Jangde (2018) The researcher had found out that the marketers spend enormous amount of nonet annually on celebrity endorsement contracts based on the belief that the celebrities are effective spokespersons for their products or brands Celebrity endorsement is viewed as a billion dollars industry in today's era. Various companies are signing deals with celebrities in the hope that by using celebrities they can accomplish a unique and relevant position in the minds of the consumers.

RELIANCE TRENDS

Reliance Trends is a leading lifestyle retail chain with over 777 retail stores across India. Reliance Trends offers stylish, high- quality products across Womenswear, Lingerie, Menswear, Kidswear and fashion accessories through a diversified portfolio of own brands, national and international brands.

The uniqueness of the store is the core, which delivers "fashion at great value". Spread over 8,000 – 24,000 square feet of shopping area, each Reliance Trends store is designed to offer a unique shopping experience for the entire family through wide aisles, coordinated displays and highly trained fashion professionals offering best in class customer assistance.

Reliance Trends customer through www.reliancetrends.com can access a large collection of fashionable, high quality products at great value delivered at their door steps.

LIMITATION OF THE STUDY

- This study is confined only to Coimbatore City.
- This study is carried out for a certain period of time.
- The validity of response from the respondents is questionable due to their Bias.

ANALYSIS

TABLE SHOWS THE LEVEL OF SATISFACTION OF THE RESPONDENTS ABOUT CELEBRITY ADVERTISEMENT AN IMPORTANT FACTOR IN PURCHASING A PRODUCT

S. NO.	FACTORS	NO. OF RESPONDENTS	LIKERT SCALE VALUES(x)	TOTAL (fx)
1	Strongly Agree	18	5	90
2	Agree	47	4	188
3	Neutral	20	3	60
4	Disagree	15	2	30
5	Strongly Disagree	10	1	10
	TOTAL	110		378

(Source: Primary data)

$$\begin{aligned} \text{Likert scale} &= \sum(fx) / \text{Total number of respondents} \\ &= 378/110 \\ &= 3.4 \end{aligned}$$

INTERPRETATION

Likert scale value 3.4 which is equal to the mid value 3, so the respondents

are neutral about celebrity advertisement an important factor in purchasing a product.

**TABLE SHOWS THE PERFORMANCE OF THE RELIANCE TRENDS**

S. NO	PARTICULARS	1	2	3	4	5	6	7	8	TOTAL SCORE	RANK
1	Price	7(8) 56	15(7) 105	21(6) 126	11(5) 55	21(4) 84	17(3) 51	10(2) 20	8(1) 8	505	5
2	Quality	25(8) 200	32(7) 224	22(6) 132	10(5) 50	9(4) 36	8(3) 24	3(2) 6	1(1) 1	673	1
3	Collections	21(8) 168	23(7) 161	35(6) 210	15(5) 75	3(4) 12	5(3) 15	7(2) 14	1(1) 1	656	2
4	Offers	10(8) 80	20(7) 140	21(6) 126	30(5) 150	10(4) 40	8(3) 24	5(2) 10	6(1) 6	576	4
5	Advertisements	15(8) 120	21(7) 147	28(6) 168	16(5) 80	14(4) 56	11(3) 33	3(2) 6	2(1) 2	612	3
6	Convenience	5(8) 40	13(7) 91	14(6) 84	6(5) 30	15(4) 60	20(3) 60	18(2) 36	19(1) 19	420	7
7	Payment Method	5(8) 40	11(7) 77	10(6) 60	8(5) 40	4(4) 16	14(3) 42	34(2) 68	24(1) 24	367	8
8	Customer Service	10(8) 80	10(7) 70	12(6) 72	8(5) 40	17(4) 68	21(3) 63	15(2) 30	17(1) 17	440	6

*(Source: Primary data)***INTERPRETATION**

The above table shows that the Quality is rank 1, Collections are rank 2, Advertisements is rank 3, Offers are rank 4, Price is rank 5, Customer service is rank 6, Convenience is rank 7, Payment method is rank 8.

- Quality is ranked 1 based on the respondents ranking towards the performance of Reliance Trends.

FINDINGS, SUGGESTIONS AND CONCLUSION**FINDINGS****SIMPLE PERCENTAGE**

- 63% of the respondents are Male.
- 42% of the respondents are Below 25 years.
- 45% of the respondents are Graduates.
- 51% of the respondents are Unmarried.
- 36% of the respondents are Private Employees.
- 35% of the respondents are earning Rs 30,000 – Rs 60,000.
- 78% of the respondents are Nuclear family.
- 70% of the respondents like to watch advertisements.
- 51% of the respondents watch television advertisements
- 47% of the respondents came to know about Reliance Trends through Friends and relatives.
- 100% of the respondents have visited Reliance Trends.
- 48% of the respondents visit Occasionally.

- 29% of the respondents spend Rs 2,000- Rs 5,000 and 29.1% of the respondents spend above Rs 5,000.
- 31% of the respondents are influenced by Quality.
- 57% of the respondents have noticed Keerthi Suresh.
- 54% of the respondents says sales is enhanced by Cinema actors.
- 54% of the respondents would not switch from their regular products to a new product advertised by their favorite celebrity.

LIKERT SCALE

- Likert scale value 3.2 which is equal to the mid value 3, so the customers are neutral in buying a product advertised by a celebrity.
- Likert scale value 3.5 which is greater than the mid value 3, so the customers agree that they get attracted with the product advertised by celebrities.
- Likert scale value 3.5 which is greater than the mid value 3, so the customers agrees that the celebrity advertisements are effective than the other type of advertisements.
- Likert scale value 3.7 which is greater than the mid value 3, so the customers agrees that they can recognize the product or brand by with the help of celebrities in the advertisements
- Likert scale value 3.8 which is greater than the mid value 3, so the customers agrees that the celebrity advertisements grab the audience's attention more than a standard ad.



- Likert scale value 3.6 which is greater than the mid value 3, so the respondents agree that the celebrities in the advertisements help to identify the product which they are associated with.
- Likert scale value 3.1 which is equal to the mid value 3, so the customers are neutral about the trustworthiness of the product endorsed by celebrities.
- Likert scale value 3.6 which is greater than the mid value 3, so the respondents agree that the advertisements which involve celebrities give a positive image to the product.
- Likert scale value 2.7 which is equal to the mid value 3, so the respondents are neutral about stop buying the product/ brand if their favorite celebrity stops advertising it.
- Likert scale value 3.4 which is equal to the mid value 3, so the respondents are neutral about celebrity advertisement an important factor in purchasing a product.

RANK ANALYSIS

- Quality is ranked 1 based on the respondents ranking towards the performance of Reliance Trends.

SUGGESTIONS

- Celebrity advertisements will be more effective when using a celebrity who is not already strongly associated with another product or service.
- Celebrity advertisements can be telecasted regularly can increase the sales rather than telecasting it occasionally
- The company may increase the sales through reducing the product price without compromising on quality.
- Companies need to make good judgements on consumer's needs and interests for a specific product. The practical functions and benefits of a product should be presented in the advertisements
- Companies should carefully choose and evaluate a popular celebrity to promote their product and services. As most of the respondents are influenced by cinema actors it is better to choose a cinema actor to endorse their product.

CONCLUSION

During the evolution of fashion, it plays an important role in every people's lives and it has also become the deciding factor of people's societal status. New generation is liking to be

presentable and to flow with the trend. Among people, especially women prefer RELIANCE TRENDS because of new collections, quality and more offers. The collections from reliance trends has also become trend setter dresses. They have their own place in the market. For South India, the celebrity who advertise are Keerthi Suresh and Rana Daggubatti. As Coimbatore comes under south India, Sales in enhanced by Keerthi Suresh for women collections and Rana Daggubati for men collections

REFERENCES

1. Danish Hussain and Kaleem M Khan, "A study on understanding the effectiveness of celebrity endorsements", Aligarh Muslim University, Volume 09, Issue January, 2019.
2. Ankita Jangde "A study on understanding shoppers behaviour of customer experience at reliance retail" International journal of research, Issue August 2018.
3. Sowmya and prof. Jyoti Ainapur "A study on impact of store design and layout in customer at reliance trends" International journal for scientific researcher & Development, volume05, Issue 06,2017.
4. Kodhainayaki.N and Dr. Jayachandran.R "A study on impact of celebrity endorsement on purchase of beauty care products", International journal of multidisciplinary research and development, volume 3, issue September, 2016.
5. Akansha Bhargava "A study on proliferation of the role of celebrity endorsements", Advances in economics and business management, volume 2, Issue January-march, 2015.

WEBSITES

www.wikipedia.com
www.relianceretail.com



A STUDY ON CONSUMERS' SATISFACTION ON MCDONALD'S IN COIMBATORE CITY

Krithika. C

*Student of III B.Com (PA), Department of Commerce with Professional Accounting,
Dr. N.G.P Arts and Science College (Autonomous), Coimbatore*

Dr. D. Sivasakthi

*Associate Professor, Department of Commerce with Professional Accounting (Autonomous),
Dr. N.G.P Arts and Science College, Coimbatore*

ABSTRACT

The state of satisfaction depends on a number of both psychological and physical variables which correlate with satisfaction behaviors such as return and recommend rate. Customer satisfaction is a marketing tool and a definite value added benefit. It is often perceived by customers as important as the primary product offers organization your service. The purpose of this study is to understand the factors influencing consumer satisfaction towards MCDONALD'S. Primary, secondary data and sample techniques is used for the study, sample size – 120 respondents, these are the research methodologies that are been used.

- ✓ *Simple percentage analysis.*
- ✓ *Ranking analysis.*
- ✓ *Likert analysis.*

These are the statistical tools. Majority (54.2%) are Male and the quality of McDonald's ranks 1, these are the findings if the analysis. This study was conducted in Coimbatore city, McDonald's offer quality food which influence the consumer to choose it.

KEY WORDS: *Mc Donald's, Fast food, Satisfaction, Customer.*

INTRODUCTION

Customer satisfaction a term frequently used in marketing is a measure of how products and service supplied by a company meet or surpass customer expectation. Customer satisfaction is defined as “the number of customers, or percentage of total customers whose reported experience with a firm its products or its services (rating) exceeds specified satisfaction goals.

The state of satisfaction depends on a number of both psychological and physical variables which correlate with satisfaction behaviors such as return and recommend rate. The level of satisfaction can also vary

depending on other option the consumer may have and other products against which the consumer can compare the organization products.

Customer satisfaction is a marketing tool and a definite value added benefit. It is often perceived by customers as important as the primary product offers organization your service. Customer satisfaction is a measure of how products and services supplied by a company meet or surpass customer expectation.



STATEMENT OF THE PROBLEM

In order to maintain brand loyalty from the loyal customer and attract new potential customer and attract new potential customer, McDonald's need to study the level of customer satisfaction for the food and service it provide. When consumer thinks about the convenience and price of an eating place has an important role in determining the growth of fast food. Also to compete the competitors in the market and to satisfy the emerging needs of the consumer.

SCOPE OF THE STUDY

The study has been undertaken to know the customer satisfaction of Mc Donald's in Coimbatore city. This would help Mc Donald's to know the level of satisfaction and expectations of their customers, the impacts of different features of their service and the ways to improve their service which would increase both sales and reputation.

OBJECTIVES OF THE STUDY

The objective of the study can be laid down as follows

- To examine the factors influence to purchase of McDonald's..
- To understand the needs of the customer of McDonald's
- To identify the overall satisfaction among the customers in McDonald's.

RESEARCH METHODOLOGY

DATA COLLECTION

Both primary and secondary data were used.

PRIMARY DATA

Primary data is the data that is collected for the first time by the researcher. The primary data are collected with specific set of objective to assess the current status of any variable studied. The primary data were collected using structure questionnaire in Google form.

SECONDARY DATA

Source of secondary data include journals, websites, etc. All this helped in authenticating the kind of information obtained from our primary sources and thus helped to get a very objective view of the study.

RESEARCH DESIGN

AREA OF THE STUDY

The study is conducted only in Coimbatore city.

SAMPLE SIZE

For the study sample size of 120 respondents.

SAMPLE METHOD

The McDonald's in Coimbatore city from among all the McDonald's outlet 120 respondents are choosen as samples on convenience basis.

TOOLS FOR ANALYSIS

- ✓ Simple percentage analysis.
- ✓ Ranking analysis.
- ✓ Likert analysis.

LIMITATIONS OF THE STUDY

- The study is limited to the information given by only 120 respondents in Coimbatore city.
- It is possible that the information provided by the respondents may be incorrect.

REVIEW OF LITERATURE

Ali Kara, et.al (1995) The overall goal of the study is to determine whether the same fast food restaurants are received similarly differently across the two countries and whether they are positioning can be improved careful and selective promotion. It also reveals that the major trend in the USA and Canada and in most of the industrial world is that more people are eating meals outside their home.

Bahaudin G. Mujtaba(2007) This study reveals about the McDonald's system providing employment and growth opportunities to a vast number of minority groups in the United States and people around the globe. Their commitment to opportunity also includes support for their employee's education. For example, McDonald's Hong Kong offers employees free continuing education courses in business.As a result of McDonald's efforts, today Hispanics represent 29.3 percent of its workforce and 18 percent of its restaurant managers.

Jing Han(2008) The study is about how McDonald's applies the strategies and how their strategies interact with their business structure and the external environment. It also reveals about achieving their objectives, the McDonald's strategy should be attract more new customers, encourage existing customers to visit McDonald's more often, build brand loyalty and, ultimately, create enduring profitable growth for the company.



DATA ANALYSIS AND INTERPRETATION

The data collected from the samples have systematically applied and presented in tables under various headings in the following pages. They were also arranged in such a way that, a detailed analysis can be made so as to present suitable interpretations for the same. The data have been analyzed using the following statistical tools.

- 4.1 Simple percentage analysis
- 4.2 Likert scale analysis
- 4.3 Rank analysis

FORMULA

$$\text{PERCENTAGE} = \frac{\text{Number of Respondents}}{\text{Total number of respondents}} \times 100$$

SIMPLE PERCENTAGE ANALYSIS

The Percentage analysis is mainly employed to find the distribution of different categories of respondents. As the value are expressed in percentage it facilitates comparison and standardization. This analysis describes the classification of the respondents failing under each category.

Table No: 1

Table showing GENDER of the respondents

S.NO	PARTICULARS	NO.OF RESPONDENTS	PERCENTAGE
1	MALE	65	54.2
2	FEMALE	55	45.8
TOTAL		120	100

(Source: Primary Data)

INTERPRETATION

It is revealed that 54.2% of the respondents are Male and the 45.8% of the respondents are Female. **Majority 54.2% of the respondents are Male.**

LIKERT SCALE ANALYSIS

A Likert scale analysis is a method of meaning attitude. Ordinal scale of responses to a question or statement. Ordered in hierarchical sequence from strongly negative to strongly positive. Used mainly in behavioural science, in likert's methods a person's attitude is measured by combining (adding pr averaging) their responses all items.

FORMULA:

$$\text{LIKERT SCALE} = \frac{\sum(FX)}{\text{NUMBER OF RESPONDENTS}}$$

$$F = \text{NO.OF RESPONDENTS}$$

$$X = \text{LIKERT SCALE VALUE}$$

$$(FX) = \text{TOTAL SCORE}$$

MID VALUE:

Mid-Value indicates the middle most value of the likert scale.



Table No: 2
Table showing Agree and Disagree HOME DELIVERY of respondents

S.NO	FACTORS	NO. OF THE RESPONDENTS(F)	LIKERT SCALE VALUE(X)	TOTAL(FX)
1	Strongly Agree	37	5	185
2	Agree	50	4	200
3	Neutral	24	3	72
4	Disagree	5	2	10
5	Strongly Disagree	4	1	4
TOTAL		120		471

(Source: Primary Data)

$$\begin{aligned} \text{Likert scale} &= \frac{\sum(FX)}{\text{total no. of respondents}} \\ &= \frac{471}{120} \\ &= 3.925 \end{aligned}$$

INTERPRETATION: Likert scale value is 3.925 greater than the middle value(3), so the consumers are agree in the home delivery.

RANK ANALYSIS

A Rank analysis is any of several satisfies that measure an ordinal association. The relationship

between ranking of different ordinal variables or different ranking of the same variable, where a “ranking” is the assignment of the label “first”, “second”, “third”, etc. to different observations of a particular variable. A rank analysis measures the degree of similarity between two rankings, and can be used to assess the significance of the relation between them.

TABLE NO: 3
TABLE SHOWS MOST INFLUENCE DECISION TO EAT MCDONALD'S (RANKING ANALYSIS)

S.NO	FACTORS	RANK I	RANK II	RANK III	RANK IV	RANK V	TOTAL SCORE	RANK
1	Quality	36(5)	26(4)	23(3)	31(2)	4(1)	419	1
2	Taste	23(5)	35(4)	25(3)	31(2)	6(1)	398	3
3	Price	17(5)	34(4)	43(3)	23(2)	3(1)	399	2
4	Easy delivery	13(5)	36(4)	31(3)	34(2)	6(1)	376	5
5	Service	15(5)	43(4)	25(3)	24(2)	13(1)	383	4

(Source: Primary data)

INTERPRETATION

The table 4.3.1 shows that the out of 120 respondents, Quality is in the rank1, Price is in the rank 2, Taste is in the rank 3, Service is in rank 4 and Easy delivery is in the rank 5.

INFERENCE: It resulted that Quality is in rank land it influences the respondents to take decision to eat at McDonald's.

FINDINGS

SIMPLE PERCENTAGE ANALYSIS

- Majority 54.2% of the respondents are Male.
- Majority 79.2% of the respondents are 18-27years.

- Majority 81.7% of the respondents are Unmarried.
- Majority 56.7% of the respondents are Graduate in Degree.
- Majority 40.8% of the respondents Occupation is Others.
- Majority 33.3% of the respondents are earning Below Rs.10,000.
- Majority 37.5% of the respondents are Advertisement.
- Majority 54.2% of the respondents prefer Chicken Strips.
- Majority 34.2% of the respondents use Occasionally.



- Majority 36.7% of the respondents are Rs. 501-1000.
- Majority 56.7% of the respondents are Very good.

- ❖ McDonald's should consider in making more varieties of food in addition to satisfy the consumer.
- ❖ Many more combos can be introduced for the customers who don't have patience.

LIKERT SCALE ANALYSIS

- ❖ Likert scale value is 3.925 greater than the middle value(3), so the consumers are agree in the home delivery.
- ❖ Likert scale value is 3.642 greater than the middle value(3), so the consumers are agree in the delivery time .
- ❖ Likert scale value is 3.692 greater than the middle value(3), so the children are agree in the McDonald'.
- ❖ Likert scale value is 3.775 greater than the middle value(3), so the consumers are Agree in the easy to place order.
- ❖ Likert scale value is 3.65 greater than the middle value(3), so the consumers are Argee in the expectations level.
- ❖ Likert scale value is 2.99 greater than the middle value(2), so the consumers are Agreed in the price.
- ❖ Likert scale value is 2.78 greater than the middle value(2), so the consumers are Agreed in the taste.
- ❖ Likert scale value is 2.82 greater than the middle value(2), so the consumers are Agreed in the flavour.
- ❖ Likert scale value is 2.7 greater than the middle value(2), so the consumers are Agreed in the the colour.
- ❖ Likert scale value is 2.9 greater than the middle value(2), so the consumers are Agreed in the delivery.

RANK ANALYSIS

- It resulted that quality of McDonald's is in the rank 1 and it influences the respondents to take decision to eat at McDonald's.

SUGGESTIONS

- ❖ The consumers suggests that the improvement must be made on service and delivery.
- ❖ The study suggested by the consumers is that the price may be little bit reduced without compromising the quality of the product.
- ❖ Improvement can be made in serving the food faster and the customer must be cared at once he enter the restaurant without any delay.

CONCLUSION

McDonald's mainly concentrates on the taste, quality, location and price. These are the major determinants of satisfaction level of it's customers. It has been concluded from the study that the quality of McDonald's secures the top position among all other satisfaction determinants. The restaurant should be automated and whatever be the change in menu or type of foods, they must be careful in providing their customers healthy and nutritional food. Improved concentration on delivery process and satisfaction of consumer expectation would increase the sales rate. The study also reveals that the highly recommended product in McDonald's by the consumer is McChicken. In McDonald's, as taste is the foremost consideration of food products the satisfaction level of McDonald's is good. But to be satisfactory, it must rectify the defects of its service.

REFERENCE

1. Ali Kara, ErdenerKaynak & Orsay Kucukemiroglu (1995), "Marketing Strategy for Fast Food Restaurants: A Customer View", *International Journal of Contemporary Hospitality Management*;7,4; pp.no:16-22.
2. Bahaudin G. Mujtaba (2007) "McDonald's Success Strategy and Global Expansion Through Customer Brand Loyalty", *Journal of Business Case Studies*, Volume 3, Issue 3, pp.no:55-66.
3. Jing Han (2008), "The Business Strategy of McDonald's", *International Journal of Business and Management*, Volume 3, Issue 11, pp.no:72-74.



A STUDY ON CUSTOMERS' SATISFACTION TOWARDS WATER PURIFIER WITH SPECIAL REFERENCE TO COIMBATORE CITY

K. Sowmya

*Student of III B.Com.(PA), Department of Commerce With Professional Accounting,
Dr.N.G.P Arts and Science College, Coimbatore*

Dr. R. Mayilsamy

*Assistant Professor, Department Of Commerce with Professional Accounting,
Dr. N.G.P Arts and Science College, Coimbatore*

ABSTRACT

Water is the most common liquid on earth pure drinking water is necessary for human survival. Water purifier is very much connected to the history of water itself. The main objective of the study is to know the satisfaction level of consumers towards water purifier. The absolute best technology now available for treating water and removing undesirable contaminants is water purifier will remove more contaminants and provide safer, healthier drinking water.

KEY WORDS-*Water purifier, Simple percentage analysis, Likert scale analysis, Ranking analysis.*

INTRODUCTION

Water purification or filtering is very much connected to the history of water itself. As the population grew, water becomes highly contaminated which led to the emergence of the need for pure, clean drinking water. Although the evolution of best water purifiers took ages but people did realize the importance of it.

Water is the most common liquid on earth pure drinking water is necessary for human survival. The water supply for drinking water is either ground or surface water. The water from its source contains sediments and other solids. Many different processes are used to obtain the finished product of clean water. There is lack of developed infrastructure due to poor economic situations. To accomplish these objective impurities such as sediments must be remove and bacteria must be killed along other microorganisms.

STATEMENT OF THE PROBLEM

Purified drinking water is essential to every citizen. The government cannot provide this to the entire population of a country. In a democratic country, different procedures of different water purifier machines are entering the market with varied

features. The consumer may not aware of the suitable machines depending on their acceptability. It is pertinent to know how for the consumers use the RO machines and to what extent and whether they are contended with the available machines. Now days, the pollution is in every form and ever increasing with adulteration. In these alarming situation, it is imperative to study the impulse of using water purifier machines.

SCOPE OF THE STUDY

The scope of the study is to know the level of satisfaction of consumer with respect to product and services of different company's water purifier. This study is aiming to know the best marketing strategy. It also aims to know the awareness about different brands of water purifiers in the market. Consumer satisfaction is dynamic, therefore it is necessary to study analysis and monitoring effective decisions can be taken in respect of product, price, models, and design of water purifier machines.

OBJECTIVES OF THE STUDY

- To analyze the awareness about water purifier.



- To find out the factors which are affecting consumer perception regarding water purifier?
- To study the satisfaction level of consumers towards water purifier.
- To analyse the problems faced by consumers in using water purifier

water in the purification process. She concluded that large section of public are spending a lot of installation of purifier or buy purified water for their survival.

Dr.A.Gunasundari et al (2018), the study entitled “A COMPARATIVE STUDY OF FACTORS AFFECTING CONSUMER PREFERENCE BETWEEN LOCAL AND BRANDED WATER PURIFIERS WITH SPECIAL REFERENCE TO THIRUVARUR”.The study examined on the perception of consumer and consumer awareness towards water purifiers. To analyze the impact of brand preference and find out factors affects consumer purchase decision. They found branded purifier needs less service after installation compare to local ones. They suggested customer service should be given an utmost priority. They concluded with rapidly changing technology consumers perception is frequently changing.

Dr.S.Prakash, Deepak Toppo (2018), the study entitled “SOLAR ENERGY BASED WATER PURIFICATION SYSTEM”. The study examined water purifier which works on solar energy. Moreover RO is a good disinfectant process. They concluded that solar energy is used for the purification of water and micro controller is also prevents the water from overflowing.

RESEARCH METHODOLOGY RESEARCH DESIGN

The research design refers to the overall strategy that you choose to integrate the different components of the study in a coherent and logical way: Research design is a plan that specifies the source and type of information relevant to the research problem.

It is the strategy specifying which approach will be used for gathering and analyzing the data and thereby, it constitutes the blueprint for the collection, measurement and analysis of data.

DESCRIPTIVE RESEARCH

Descriptive research is a study designed to depict the participant in an accurate way. It is typically concerned with determining the frequencies with something occur or determining the degree to which variables is associated.

LIMITATIONS OF THE STUDY

- Findings are based on sample survey through questionnaire method.
- The sample size has been restricted to 120 samples due to time constraint.

REVIEW OF LITERATURE

Dr. V. Maheswari (2019), the study entitled “A STUDY ON CONSUMER PERCEPTION AND SATISFACTION OF WATER PURIFIER IN KUMBAKONAM TOWN”. The study examined purified drinking water is essential to every citizen. To know the level of satisfaction on water purifier and problem faced by the respondents in using the water purifier. She found that majority 69% of the respondent were satisfied overall performance of the brand. She suggested most of the respondents have pinpainted to reduce wastage of

STATISTICAL TOOLS USED

To analyze and interpret collected data the following statistical tools were used.

- Simple Percentage Method
- Likert Scale Method
- Ranking Analysis

SIMPLE PERCENTAGE ANALYSIS

The percentage analysis is mainly to find the distribution of different categories of respondents.As the value expressed in percentage it facilities comparison and standardization. This analysis describes the classification of the respondents filling under each category.

$$\text{PERCENTAGE} = \frac{\text{Number of respondents}}{\text{Total number of respondents}} \times 100$$



TABLE NO: 1
TABLE SHOWING GENDER OF THE RESPONDENTS

S.NO	GENDER	NO.OF RESPONDENTS	PERCENTAGE (%)
1	Male	59	49
2	Female	61	51
	TOTAL	120	100

(Source: Primary Data)

INTERPRETATION

Table 4.1 shows that (49%) respondents are male and (51%) respondents are female.

- ❖ Majority (51%) respondents are female.

LIKERT SCALE ANALYSIS

Likert scales are a common ratings format for surveys. Respondents rank quality from depth to

low or best to worst using five or seven levels. Likert items are used to respondent's attitudes to a particular question or statement. To analyse the data, it is availability coded as follows.

- 5 = Highly Satisfied
- 4 = Satisfied
- 3 = Neutral
- 2 = Dissatisfied
- 1 = Highly Dissatisfied

$$\text{Likert Scale} = \frac{\sum fx}{\text{Total No. Of. Respondents}}$$

TABLE NO: 2

TABLE SHOWING LEVEL OF SATISFACTION OF THE RESPONDENTS TOWARDS PRICE IN USING WATER PURIFIER

S.NO	PRICE	NO.OF RESPONDENTS	LIKERT SCALE VALUE (X)	TOTAL (FX)
1	Highly Satisfied	48	5	240
2	Satisfied	54	4	216
3	Neutral	12	3	36
4	Dissatisfied	6	2	12
5	Highly Dissatisfied	0	1	0
	TOTAL	120	15	504

$$\begin{aligned} \text{Likert Value} &= \sum (FX) / \text{No. of. Respondents} \\ &= 504 / 120 \\ &= 4.2 \end{aligned}$$

INTERPRETATION

Likert scale value is 4.2. So, the customers are Highly Satisfied with Price.

RANK CORRELATION

The Karl Pearson's method is based on the assumptions that population being studied is normal or when the shape of the distribution is not

known, there is need for a measure of correlation i.e. need for correlation that involves no assumption above the parameter of population. It does not matter which way the items are ranked, item number one may be the largest or it be smallest using ranks rather than actual observation gives the coefficient rank correlation.



TABLE NO: 3
TABLE SHOWING THE PROBLEMS FACED BY THE RESPONDENTS IN USING WATER PURIFIER

S.NO	PROBLEMS	RANK 1	RANK 2	RANK 3	RANK 4	RANK 5	TOTAL SCORE	FINAL RANK
1	Technical problem	28(5)	42(4)	18(3)	16(2)	16(1)	410	II
2	Cost of changing the installation	26(5)	23(4)	20(3)	31(2)	20(1)	364	III
3	Lack of spares availability	36(5)	14(4)	26(3)	21(2)	23(1)	479	I
4	High flow of waste water	14(5)	18(4)	23(3)	35(2)	30(1)	311	V
5	Taste and Odour	16(5)	24(4)	32(3)	17(2)	31(1)	337	IV

INTERPRETATION

Table 4.17, it is understood that the sample respondents are given first rank in facing the problem of Lack of spares availability, they are given second rank in facing the problem of Technical problem, they are given third rank in facing the problem of Cost of changing the installation, they are given fourth rank in facing the problem of Taste and Odour, they are given fifth rank in facing the problem of High flow of waste water.

In this study the majority of the respondents are given first rank in facing the problem of Lack of spares availability.

FINDINGS, SUGGESTIONS AND CONCLUSION

FINDINGS

SIMPLE PERCENTAGE ANALYSIS

- ❖ Majority (51%) respondents are female.
- ❖ Majority (43%) of the respondents are under the age group below 25 years.
- ❖ Majority (52%) respondents are unmarried
- ❖ Majority (48%) respondents are completed UG degree.
- ❖ Majority (52%) respondents are Private Employees.
- ❖ Majority (60%) respondents are having 4 – 5 members in their family.
- ❖ Majority (58%) respondents are Nuclear family.
- ❖ Majority (45%) respondents are earning monthly income of Rs.20001 –Rs.40000.

- ❖ Majority (33%) respondents are using water purifier with the brand of Aquaguard.
- ❖ Majority (34%) respondents are influenced by Businessmen for buying the water purifier.
- ❖ Majority (38%) respondents are using Municipal water.
- ❖ Majority (63%) respondents are feeling as good in the taste of water by using water purifier.
- ❖ Majority (38%) respondents are agreed with purifying technologies.

LIKERT SCALE ANALYSIS

- Likert scale value is 2.47. So, the customers are very good with price.
- Likert scale value is 2.29. So, the customers are good with Design.
- Likert scale value is 2.43. So, the customers are Very Good with Availability of Products.
- Likert scale value is 2.35. So, the customers are Very Good with Quality
- Likert scale value is 2.36. So, the customers are Very Good with Brand Name.
- Likert scale value is 2.33. So, the customers are good with Performance.
- Likert scale value is 4.2. So, the customers are Highly Satisfied with Price.
- Likert scale value is 4.22. So, the customers are Satisfied with Quality.
- Likert scale value is 3.62. So, the customers



- are Satisfied with After Sales Service.
- Likert scale value is 3.69. So, the customers are Neutral with Brand Image.
 - Likert scale value is 3.98. So, the customers are Satisfied with Availability.
 - Likert scale value is 3.98. So, the customers are Satisfied with Design.
 - Likert scale value is 3.76. So, the customers are Satisfied with Performance.
 - Likert scale value is 3.57. So, the customers are Highly Satisfied with Offers and Discounts.
 - Likert scale value is 3.56. So, the customers are Satisfied with Advertisements.
 - Likert scale value is 3.75. So, the customers are Satisfied with Warranty and Guarantee.

RANK ANALYSIS

- ✓ In this study the respondents are given first rank to the factor of Quality.
- ✓ In this study the majority of the respondents are given first rank in facing the problem of Lack of spares availability.

SUGGESTIONS

- Warranty and guarantee may be increased
- The latest technologies may be implemented in affordable price
- Low budget water purifier may be developed for urban people

CONCLUSION

Water treatment is often necessary if surface water supplies and sometimes ground water supplies are to be available for human use. Because the vast majority of the cities use one water distribution system for household industries and hospitals etc., large quantities of water often must be made available to satisfy the highest water purifier usage.

The threat of harmful contaminants in drinking water can no longer be reasonably ignored. The correlation between contaminated drinking water and many significant diseases and health problems is far too strong to discount. There are many home treatment alternatives that can purify drinking water to a greater extent than city treatment plants. Reverse osmosis and distillation, two of these alternatives are moderately successful at removing some contaminants but they are expensive and wasteful. The absolute best technology now available for treating water and removing undesirable contaminants is water purifiers when compared to any other water

treatment alternative will remove more contaminants and provide safer, healthier drinking water.

REFERENCE

1. Dr.V.Maheswari(2019), "A study on consumer perception and satisfaction of water purifier in Kumbakonam town". Volume-6, Issue 2, March – April 2019, pp: 240–246, ISSN Print: 2347-3940 and ISSN Online: 2347-3959
2. Dr.A.Gunasundari,Dr.R.Vanitha,S.Senthilvel, V.Rengarajan,V.Vijayanand,C.Kathirvel Babu (2018) "A comparative study of factors affecting consumer preference between local and branded water purifiers with special reference to Thiruvarur".Volume-119 No.10 2018,pp: 1591-1602,ISSN Print:1311-8080,ISSN Online:1314-3395.
3. Dr.S.Prakash, Deepak Toppo (2018) "Solar energy based water purification system". Volume-119 No.12 2018, pp:7863-7873 ISSN Online :1314-3395.



A STUDY ON IMPACT OF SOCIAL MEDIA ON CONSUMER BUYING BEHAVIOUR WITH SPECIAL REFERENCE TO COIMBATORE CITY

Mr. A. David

*Assistant Professor, Department of Commerce with Professional Accounting
Dr N.G.P. Arts and Science College (Autonomous), Coimbatore*

Padmapriya S

*III B.Com (Professional Accounting), Dr N.G.P. Arts and Science College (Autonomous)
Coimbatore*

ABSTRACT

Social Media have provides new opportunities to consumer to engage in an social interaction on internet. Now a days, Consumers use social media to online communities, to generate content and to network with other users. The social media have changed the power structure at the place where goods sold and purchased online with marketing tools and techniques. The study observed that consumers are adapting to online marketing and their buying behavior is being influenced accordingly. The aim of this paper is to study the impact of social media on consumer buying behavior.

KEYWORDS: *Social media, consumer behavior, decision making process.*

INTRODUCTION OF THE STUDY

In this paper, a study is made of the consumer behavior decision process, Consumers today are progressively utilizing technology and particularly Social Media as an effective tool in their online shopping process. Social media puts consumer back to the center of the business world and provides marketers a new set of tools and techniques to interact with consumer and to integrate them into the brands through innovative manner. Therefore, these media become a crucial media to introduce and market product and conjointly to try to surveys. The study examines the direct or indirect influence of social media on trust and intension of the consumer buying behavior.

STATEMENT OF THE PROBLEM

Consumers are beginning to resist the effect of some companies at marketing them. The promotional focus of some organizations is on the conventional mass media advert style, which includes commercial TV, radio jingles and advertisements in print formats such as newspapers and magazines along with billboard placements. It is now on record that as the

Internet is fast advancing across the global marketplace, the effectiveness of traditional mass media is fast on the decline.

SCOPE OF THE STUDY

- The scope of this research is to focus the level of consumer buying behaviour from social media in Coimbatore city.
- Understand the behavior of consumer and factors affecting consumer buying behaviour.
- It involves the analyzing the customer satisfaction towards social media.

OBJECTIVES OF THE STUDY

- To analyses the impact of social media on consumer buying behaviour.
- To study the development of trust into consumers by social media.
- To study the impact of social media on various stages of decision-making process of consumers.

**SOURCE OF DATA COLLECTION**

The present study, is based on a survey conducted in Coimbatore city with the help of both Primary data, Secondary data.

Primary data

In primary data, the data has been collected through the questionnaire.

Secondary data: The secondary data was collected by going through websites, Marketing journals and articles.

RESEARCH METHODOLOGY

- **Research design:** The descriptive research design was applied in the research methodology of the study.
- **Sample size:** The 120 samples are decided to selected from Coimbatore city
- **Tools for analysis**
 - Percentage analysis
 - Likert scale analysis
- **Area of study:** Coimbatore city was the area of the study

REVIEW OF LITERATURE

M. Nick Hajli (2013), The report is based on the Online communities and social networking sites (SNSs) are an effective web technology for social interactions and sharing information, this is an important point as customer involvement through social media is a key factor in marketing.

Duangruthai Voramontri, Leslie Klieb (2018), The goal of this paper is to research empirically the role of social media in consumers' decision-making process for complex purchases those characterized by significant brand differences, high consumer involvement and risk, and which are expensive and infrequent. The model uses the information search, alternative evaluation, and purchase decision stage. With such vast information freely available on social media, it is up to businesses to harness it positively to improve their product offerings, their customer relationship management, and their profitability.

ANALYSIS**TABLE SHOWING TYPE OF SOCIAL MEDIA INFLUENCE PURCHASE OF THE RESPONDENTS**

S.NO	TYPE OF SOCIAL MEDIA	NO. OF RESPONDENT	PERCENTAGE (%)
1	Instagram	68	56.7%
2	Facebook	14	11.7%
3	Twitter	2	1.7%
4	YouTube	20	16.6%
5	Others	16	13.3%
	TOTAL	120	100

(Source: Primary Data)

INTERPRETATION OF Data

The above table shows 56.7% of the respondent use Instagram, 11.7% of the respondent use Facebook, 1.7% of the respondent use Twitter, 16.6%

of the respondent use YouTube, 13.3% of the respondent use Other social media networks.

Majority 56.7% of the respondents purchase influence on Instagram.

TABLE SHOWING INFLUENCED PURCHASE LEVEL

Factors	No. of Respondents	Likert Scale	Total Score (fx)
Strongly agree	22	5	110
Agree	65	4	260
Neutral	27	3	81
Strongly disagree	2	2	4
Disagree	4	1	4
Total	120	15	459

(Source: Primary Data)

FORMULA

$$\begin{aligned} \text{Likert scale} &= \sum(fx) / \text{Total number respondents} \\ &= 459/120 \\ &= 3.82 \end{aligned}$$



INTERPRETATION OF TABLE

Likert scale value is 3.73 is greater than the mid value (3). Hence the majority of the respondents are Agree the influenced purchase.

FINDINGS

1. SIMPLE PERCENTAGE ANALYSIS

- ❖ The study finds 50.8% of the respondents were Female.
- ❖ The survey status that 72.5% of the respondents were 18-25 years.
- ❖ Majority 76.7% of the respondents were Graduate.
- ❖ Majority 63.3% of the respondents were Students.
- ❖ The survey states that 81.7% of the respondents were Unmarried.
- ❖ From the study 68.3% of the respondents Annual Income were Below Rs 3 lakhs.
- ❖ Majority 64.2% of the respondent were using social networking sites on the daily basis.
- ❖ Survey finds that 48.3% of the respondents were using 3-5 hours per day on Social Media.
- ❖ Majority 56.7% of the respondents purchase influence on Instagram.
- ❖ Majority 44.2% of the respondents were using social media Daily to find information about the product/service.
- ❖ Majority 75% of the respondents were brought a product/service after seeing it on Social Media.
- ❖ Majority 61.7% of the respondents search information on social media sites Sometimes.
- ❖ Majority 86.7% of the respondents were seeing social media to check information before buying a product.
- ❖ Majority 78.3% of the respondents were having higher credibility than on mass media channels.
- ❖ Majority 42.5% of the respondents were influence their purchasing decision through Knowledge or awareness of the product.
- ❖ Majority 44.2% of the respondents have positive thoughts towards a particular product only sometimes.
- ❖ Majority 70% of the respondents payment information is kept secure in social media networking sites.

2. LIKERT SCALE ANALYSIS:

- ❖ Likert scale value is 3.73 is greater than the mid value (2.5). Hence the majority of the

respondents are Agree to look advertisement for retail outlets on Social media.

- ❖ Likert scale value is 3.82 is greater than the mid value (2.5). Hence the majority of the respondents are Agree the influenced purchase.
- ❖ Likert scale value is 3.97 is greater than the mid value (2.5). Hence the majority of the respondents are Agree to find new products.
- ❖ Likert scale value is 3.78 is greater than the mid value (2.5). Hence the majority of the respondents are Agree to purchase after watching some sort of reviews.
- ❖ Likert scale value is 3.79 is greater than the mid value (2.5). Hence the majority of the respondents are Agree ON rely on it before making a purchasing decision.

SUGGESTION

- ❖ Consumers feels that the privacy policy to be secure in social media.
- ❖ Some of the consumer feels that wrong type of brand advertisements should be avoided.
- ❖ Maximum students and youngsters are highly dependent on social networking sites for indirect interaction.
- ❖ Now a days Peoples are highly motivated to use social networking sites to learn about new and useful things.

LIMITATIONS OF THE STUDY

- The geographical scope of the study is limited to Coimbatore city
- The sample is confined to 120
- The customer attitude may change in future

CONCLUSION

In conclusion, the findings obtained from this research, the consumers are mostly affected by informational and design factors which lead them to take the best decision in choosing the most suitable Social Media site (Instagram) to buy their preferred product (Fashion). The study also concluded that social media tools allows for one to voice their opinion after a purchase has been made and to review a product expectation and performance after buying.

REFERENCE

1. *M. Nick Hajli (2013), "A study of the impact of social media on consumers", International Journal of Market Research Vol. 5 6 Issue 3.*
2. *Duangruthai Voramontri & Leslie Klieb (2018), "Impact of social media on consumer behaviour",*



International Journal of Information and Decision Sciences.

3. **Author-Anjum Tanwar (2017)**, “Impact of Social Media on Consumer Behaviour”, *International Journal of Research*, Volume 04 Issue 06
4. **Esraa Alfeel, Dr. Zaid Ahmad Ansari (2019)**, “The Impact of Social Media Marketing on Consumer Purchase Intention: Consumer Survey in Saudi Arabia”, *An International Peer-reviewed Journal Vol.56*, 2019.



A STUDY ON CONSUMER'S BUYING BEHAVIOUR TOWARDS AROMA MILK WITH SPECIAL REFERENCE TO COIMBATORE CITY

Dr.D.Sivasakthi

*Associate Professor, Department of Commerce with Professional Accounting
Dr.N.G.P. Arts and Science College(Autonomous), Coimbatore*

C.Poorni

*Student of III B.Com (PA), Department of Commerce with Professional Accounting
Dr.N.G.P. Arts and Science College(Autonomous), Coimbatore*

ABSTRACT

Consumer buying behavior is the sum total of a consumer's attitudes, preferences, intentions and decision regarding the consumer's behavior in the market place when purchasing a product or service. However, as a larger population is migrating from rural area to cities. Thus, creates greater demand for dairy products. Milk and milk products are essentials part of human being, as it gives nutrition to all walks of life. It is a source of income for all the marginal dairy farmers. This article examine the consumer buying behavior towards AROMA MILK product with special reference to Coimbatore city. A convenient sampling technique tool was adopted for data collection. Sample size taken in this is 120 respondents. The data is collected through questionnaire. The buying behavior is positive which reveals that the buying behavior of the consumer is high. Thus the project concludes that the buying behavior of the consumers are positive, so the product has a good reach in Coimbatore city.

KEYWORDS: Consumer Behavior, Consumer Attitude and Tool for Analysis.

1.1 INTRODUCTION

Consumer buying behavior is the scientific learning of how people buy, what they buy, when they need to buy and why they buy i.e, the reason to buy. The consumer behavior is very useful in determining the form, style, packaging, brand, trademark etc., of the product. The whole aspect of buying behavior determines the durability, price policy and utility aspects in goods. The buying behavior is concerned with the study of factors that influence a person to buy or not to buy.

1.2 STATEMENT OF THE PROBLEM

- Consumer behavior is the independent variable which is highly complicated. It could

be the influence of the variable price brand image, quality of the product and regularity of service.

- Its necessary for the company to know the consumer behavior towards packaged milk of its availability, acceptance and affordability.
- The present study tries to identify the various factors and prices that lending to the consumers behavior towards packaged milk.

1.3 SCOPE OF THE STUDY

- The scope of the study is to calculate various opinion of the consumers who is using aroma milk.



- This shows the purchasing level of the product and need of the consumers.
- The present study tries to identify the various factors that leading to the consumer buying behavior towards aroma milk.

1.4 OBJECTIVES OF THE STUDY

- To study the consumer's buying behavior towards aroma milk.
- To identify the brand awareness level of consumers towards aroma milk.
- To analyses the factors influencing in buying of aroma milk.

1.5 RESEARCH METHODOLOGY

- **PRIMARY DATA**
In primary data, the data has been collected through the questionnaire.
- **SECONDARY DATA**
The secondary data was collected by going through websites, Marketing journals and articles
- **SAMPLE SIZE**
The 120 samples are collected from the respondents.
- **TOOLS FOR ANALYSIS**
 - Simple percentage analysis
 - Likert scale analysis.
- **AREA OF THE STUDY**
Coimbatore city was the area of the study.
- **SAMPLE METHOD**
Convenient sampling is used in this

research.

- **LIMITATIONS OF THE STUDY**
 - The sample size is limited to 120 respondents.
 - Consumer attitude may change in future.
 - Questionnaire is limited to collect the data.

1.6 REVIEW OF LITERATURE

Annammal. J (2019) studied consumer attitude and perception towards milk product in

thanjavur town. Consumer's life style square measured the influenced by range of things like culture values, demographic factors, status, reference teams, manage and additionally the interior makeup of the patron, which are emotions, permanent motives of shopping for perception and learning. Consumer's also are influenced by promoting activities.

Dhanya.K and Venkatesa Palanichamy.N (2018) focused on consumer buying behavior towards aroma milk products. It determines about the buying behavior of the people living in urban areas, still prefer to go for packaged milk products available in market places. As per findings, suggestion are given to the company to take initiation to fulfill the consumer needs. Industry can target that segment and use it as an opportunity to expand their sales by satisfying those consumers also by retaining the existing consumers. For that they hav to mak thir quality and availability their utmost importance to aany other factors.

1.7 DATA ANALYSIS AND INTERPRETATION

In this chapter the analysis and interpretation of the study on "Consumer buying behavior towards Aroma milk", is presented based on the opinion of samples of 120 respondents selected from Coimbatore City through a questionnaire containing 20 questions were analyzed through

- Simple Percentage analysis.
- Likert's scale.

SIMPLE PERCENTAGE ANALYSIS

Simple percentage analysis is carried out for most of all questions gives in questionnaire . this analysis describes the classification of the respondents failing each category.

The percentage analysis is used mainly for the standardization and comparisons are in support with the analysis.

**FORMULA**

Percentage = Number of respondents ÷ Total respondent × 100

TABLE 4.1.2
TABLE SHOWING THE AGES OF THE RESPONDENTS

S.NO	AGE	NO. OF RESPONDENTS	PERCENTAGE
1	Below 20	29	24.2
2	21 to 30	66	55
3	31 to 40	14	11.7
4	Above 40	11	9.2
	Total	120	100

(Source: Primary data)

INTERPRETATION

The above table shows that 24.2% of the respondents were below 20 years, 55% of the respondents were 21 to 30 years, 11.7% of the respondents were 31 to 40 years and 9.2% of the respondents were above 40 years.

Majority 55% of the respondents were 21 to 30 years.

LIKERT SCALE ANALYSIS

A Likert scale is a method of measuring attitudes, ordinal scale of responses to a question or statement, ordered in hierarchical sequences from strongly negative to strongly positive. Used mainly in behavioral science and psychiatry. In Likert scale

method, a persons attitude is measured by combining (adding or averaging) their responses across all items.

FORMULA

Likert scale value = $\frac{\sum (fx)}{\text{Total number of respondents}}$
 F = Number of Respondents
 X = Likert scale value
 (FX) = Total score

MIDVALUE

The mid-value indicates the middle most value of Likert scale.

TABLE NO: 2
OPINION ABOUT THE PRICE OF AROMA MILK.

FACTORS	NO.OF RESPONDENTS (f)	LIKERTS SCALE VALUE (x)	TOTAL SCORE (fx)
VERY HIGH	6	5	30
HIGH	38	4	152
MODERATE	74	3	222
LOW	2	2	4
VERY LOW	0	1	0
TOTAL	120		408

(Source: Primary data)

Likert scale value = $\frac{\sum (fx)}{\text{Total number of respondents}}$
 = 408/120
 = 3.4



INTERPRETATION

The likert scale value is 3.4 which is greater than the mid value(2.5) which shows that the consumers opinion about the aroma milk

1.8 FINDINGS

FINDINGS FROM PERCENTAGE

ANALYSIS

- The survey states that out 59.2% of the respondents are Male.
- The study finds out of 55% of the respondents were 21 to 30 years.
- The table showing 64.2% of the respondents were Graduate.
- Majority 59.2% of the respondents were Unmarried.
- Majority 36.7% of the respondents were Student.
- The research states that 65.8% of the respondents were Nuclear.
- Majority 50.8% of the respondents were their monthly income is below Rs.20,000.
- It finds that 92.5% of the respondents says easily available this product in market.
- The study gather out of 30% of the respondents are influenced by Family.
- Majority 44.2% of the respondents are known by Advertisements.
- The table shows that 62% of the respondents are influenced by Quality.
- Majority 43.3% of the respondents are using AROMA MILK for 1 to 2 years.
- From the study it is found that 49.2% of the respondents says that it has never leakages.
- Majority 61.6% of the respondents say its price is moderate.
- The study finally finds that 89.2% of the respondents are recommending AROMA MILK to others.

FINDINGS FROM LIKERT SCALE

ANALYSIS

- Likert scale value is 3.4 greater than mid value (2.5), so the consumers are agreed on the price.
- Likert scale value is 4.2 greater than mid value (2.5), so the consumers are agreed on the quality.

- Likert scale value is 3.9 greater than mid value (2.5), so the consumers are agreed on the flavor.
- Likert scale value is 3.9 greater than mid value (2.5), so the consumers are agreed on freshness.
- Likert scale value is 3.8 greater than mid value (2.5), so the consumers are agreed on the taste.
- Likert scale value is 3.85 greater than mid value (2.5), so the consumers are agreed on the brand image.
- Likert scale value is 3.575 greater than mid value (2.5), so the consumers are agreed on the reasonable price.
- Likert scale value is 3.8 greater than mid value (2.5), so the consumers are agreed on the availability.
- Likert scale value is 3.89 greater than mid value (2.5), so the consumers are agreed on the convenience.
- Likert scale value is 3.6 greater than mid value (2.5), so the consumers are agreed on the advertisement.
- Likert scale value is 3.8 greater than mid value (2.5), so the consumers are agreed on the product safety and hygienic.
- Likert scale value is 3.8 greater than mid value (2.5), so the consumers are agreed on the attractive packing.

1.9 SUGGESTIONS

- Some of the respondents feels that the price of the brand is very high. So the price of the brand needs to reduce.
- Consumers are expecting product safety and hygienic should be increased.
- The availability of the product should be expanded to all the areas.
- The company needs to increase the brand image.

1.10 CONCLUSION

This study is an attempt to focus attention of the consumers buying behavior towards AROMA MILK. In this present study, it is found that the cost of milk is high and people though like the taste of AROMA hesitating to buy only for this reason. Thus by improving product safety & hygienic and cost will induce the people to choose this brand and it will help them to defeat the competitors.



REFERENCES

1. **J. Annammal (2019)**, “A study on consumer behavior towards packaged milk with special reference to Arokiya milk in Thanjavur town”, *International Journal of Research*, ISSN NO:2236-6124.
2. **K. Dhanya and N. Venkatesa Palanichamy(2018)**, “An overview of consumer buying behavior towards aroma milk products in Coimbatore district, Tamil Nadu”, *International Journal of Advances in Agricultural Science and Technology*, vol.5 issue.7, pg. 109-123.



A STUDY ON CUSTOMER SATISFACTION TOWARDS RAYMOND CLOTHES WITH SPECIAL REFERENCE TO COIMBATORE CITY

Mrs. P. Dhanya

*Assistant Professor, Department of Commerce with Professional Accounting,
Dr. N.G.P Arts and Science College (Autonomous), Coimbatore*

Ms. Niveda.K

*III B.Com (Professional Accounting), Dr. N.G.P Arts and Science College (Autonomous)
Coimbatore*

ABSTRACT

Customer satisfaction is a term frequently used in marketing. It is helpful to measure of how products and services of the company meet customer satisfaction. This study mainly deals with the customer satisfaction towards Raymond clothes with preferred by respondents in Coimbatore city. Primary data was collected through a structured questionnaire of 120 respondents. And the type of sampling was convenient sampling. Based on this study the main factors that affects the customer satisfaction level are design,price,colour,brandname, variety and comfort of the product which plays a significant role in enhancing the satisfaction level.

KEYWORDS: *customer satisfaction, quality, tool for analysis.*

INTRODUCTION OF THE STUDY

Customer satisfaction is the overall essence of the impression about the supplier by the customers. This helps the customer to make strong opinion about the supplier which finally results in satisfaction or dissatisfaction. Customer satisfaction, a term frequently used in marketing, is a measure of how products and services supplied by a company meet or surpass customer expectation. Customer satisfaction is measured at the individual level, but it is almost always reported at an aggregate level. The level of satisfaction can also vary depending on other options the customer may have and other products against which the customer can compare the organization's products.

STATEMENT OF THE PROBLEM

Raymond clothes play a vital role in marketing. The success of the product depends not only, the marketing but also the customers satisfaction pattern towards their products. The study is conducted based on customer needs and wants regard to the Raymond clothes. Customer satisfaction

is one of the basic forms of any organization and is used to evaluate products and service. This study identified the satisfaction level of customer.

SCOPE OF THE STUDY

- The study also helps to know about the customers opinions on buying Raymond's in Coimbatore city.
- It also help us to know the changing needs of customer time to time. To evaluate and find out the factors which influence the customers.
- With the study we can give suggestions regarding customers satisfaction, and how far it is going to the customers opinion and to retain the existing customer as well as attracting the new potential customer.

OBJECTIVES OF THE STUDY

- To know the level of satisfaction of customer towards Raymond clothes



- To understand the factors which influence the purchase of Raymond clothes
- To study the customer opinions regarding the Raymond clothes

METHOD OF DATA COLLECTION

This study is based on both primary and secondary data.

- **Primary data**
In primary data, the data been collected through the questionnaire.
- **Secondary data**
The secondary data was collected by going through websites, marketing journals and articles.

RESEARCH METHODOLOGY

- **Research design**
The descriptive research design was applied in the research methodology of the study.
- **Sample size**
Sample size taken in this study is 120.
- **Tools used**
The following are the tools which are used in this study to validate the data:
 - Simple percentage analysis
 - Likert scale analysis
 - Rank analysis

REVIEW OF LITERATURE

Mr. S. Thangavel and Dr. P. Arumugaswamy (2017) in their article of “A study on consumer satisfaction and preference of branded clothing of men with special reference towards Coimbatore city”. The main objective of the study is to identify the factors affects the purchase behavior of consumer. The authors found that majority 70% of the respondents need a branded cloths is for satisfaction and trust in their brands. And also the respondent felt better quality is the important factor in purchase cloths. The authors conclude that by identifying the brand personalities that attract the customers, companies can identify what customers look for in a product, which may help to improve the image of the product.

T. Sreerexha and S. Praveen kumar (2018)¹ in their study titled “Consumer preference towards branded apparel purchase in coimbatore city”. The main objective of the study is to Indian apparel market in terms of market size and growth, focusing on men apparel market, women apparel market, boys and girls apparel market and to study the demographic, psychological and socio-economic factors which have influence the consumer purchase behaviour for apparel. The authors suggested that retailers an idea about the consumer decision process on apparels such a way they will plan their future strategies which will boost up their sales. The authors conclude that overall the consumer decision offer apparel purchase among their preference on apparel purchase at different occasion.

ANALYSIS

TABLE SHOWING THAT WHO INFLUENCED TO BUY RAYMOND CLOTHES

S.NO	INFLUENCE	NO OF RESPONDENTS	PERCENTAGE
1	Friends	31	25.8
2	Co-workers	3	2.5
3	Family	21	17.5
4	Brand itself	59	49.2
5	Others	6	5
	TOTAL	120	100

(Source: primary data)

INTERPRETATION

The above table shows that 25.8% of the respondents are influenced by friends, 2.5% of the respondents are influenced by co-wokers, 17.5% of the respondents are influenced by family, 49.2% of

the respondents are influenced by brand itself, 5% of the respondents are influenced by others.

Majority 49.2% of the respondents are influenced by brand itself.

**TABLES SHOWING THAT DESIGN FACTOR AFFECTING THE PURCHASE DECISION OF RAYMOND CLOTHES**

Factors	No. of Respondents	Likert Scale	Total Score (fx)
Strongly agree	39	5	195
Agree	47	4	188
Neutral	27	3	81
Strongly disagree	7	2	14
Disagree	0	1	0
Total	120	15	478

*(Source: Primary Data)***FORMULA**

$$\begin{aligned} \text{Likert scale} &= \sum(\text{fx}) / \text{Total number respondents} \\ &= 478/120 \\ &= 3.98 \end{aligned}$$

INTERPRETATION

Likert scale value is 3.98 is greater than the mid value (3). Hence the majority of the respondents are Agree the design.

TABLE SHOWS THE SATISFACTORY RATE OF RAYMOND CLOTHES

S.NO	FACTORS	RANK I	RANK II	RANK III	RANK IV	RANK V	TOTAL SCORE	RANK
1	Texture	28(5)	24(4)	20(3)	26(2)	22(1)	370	1
2	Comfort	16(5)	24(4)	28(3)	24(2)	28(1)	336	5
3	Material quality	24(5)	16(4)	26(3)	21(2)	33(1)	337	4
4	Usability of the product at different occasions	17(5)	29(4)	20(3)	38(2)	16(1)	353	3
5	Novelty value that the product provides	22(5)	28(4)	23(3)	31(2)	16(1)	369	2

*(Source: Primary data)***INTERPRETATION**

The table 4.3.1 shows that the out of 120 respondents, Texture is in the rank1, Novelty value that the product provides is in the rank 2, Usability of the product at different occasions is in the rank 3, Material quality is in rank 4 and comfort is in the rank 5.

INFERENCE: It resulted that Texture is in rank 1 of satisfactory rate of Raymond clothes.

FINDINGS**➤ SIMPLE PERCENTAGE ANALYSIS**

- The study found out of 55.8% of the respondents were female.
- The survey states that out 80% of the respondents were unmarried.
- The table showing 75.8% of the respondents are their annual income is below 3 lakhs.
- The research states that 38.3% of the respondents are known by advertisement.
- Majority 53.3% of the respondents are purchase special occasion.



- Majority 49.2% of the respondents are influenced by brand itself.
- The table shows that 53.3% of the respondents says product quality.
- It is found that 56.7% of the respondents are satisfied high.
- The study found out of 44.2% of the respondents says excellent.
- Majority 78.3% of the respondents are purchase cotton.
- The study infers that 62.5% of the respondents says very well.
- It is found that 56.7% of the respondents says quality.
- The study finally found that 92.5% of the respondents are recommend Raymond clothes to others.

➤ **LIKERT SCALE ANALYSIS**

- Likert scale value is 3.98 is greater than the mid value (3). Hence the majority of the respondents are Agree the design.
- Likert scale value is 4.18 is greater than the mid value (3). Hence the majority of the respondents are Agree the quality factor.
- Likert scale value is 3.97 is greater than the mid value (3). Hence the majority of the respondents are Agree the price factor.
- Likert scale value is 3.93 is greater than the mid value (3). Hence the majority of the respondents are Agree the comfort factor.
- Likert scale value is 4.13 is greater than the mid value (3). Hence the majority of the respondents are Agree the brand name.
- Likert scale value is 4.13 is greater than the mid value (3). Hence the majority of the respondents are Agree the colour factor.
- Likert scale value is 3.7 is greater than the mid value (3). Hence the majority of the respondents are Agree the variety factor.

➤ **RANK ANALYSIS**

- It resulted that Texture is in rank 1 of satisfactory rate of Raymond clothes.

SUGGESTIONS

- Some of the respondents feels that the price of the Raymond is very high. So the price of the brand needs to reduce.
- The customers expecting more variety of design and fashion collection in the Raymond
- Raymond should give more emphasis on new generation as they have much concern

towards their clothes and can be their prospective customers.

CONCLUSION

The study is an attempt to focus attention of the customer satisfaction towards Raymond clothes in Coimbatore city. Most of the people like and satisfied Raymond clothes due to its quality and material texture. In the present study, it is found that the cost of the Raymond clothes is high and people though like the quality of clothes without hesitating to buy only for this reason. The study concluded that by improving more designs and variety of collection will induce the people to choose this brand and it will help them to defeat the competitors.

REFERENCE

1. **T. Sreerekha and S. Praveen kumar (2018)** "Consumer preference towards branded apparel purchase in coimbatore city" *IJSDR1803012 International Journal of Scientific Development and Research (IJS DR) www.ijedr.org*.
2. **Mr. S. Thangavel and Dr. P. Arumugaswamy (2017)** "A study on consumer satisfaction and preference of branded clothing of men with special reference towards Coimbatore city". *Indian journal of research January 2017, vol.6*.
3. **K. Lakshmi Narayana and D. L. Sreenivas (2016)** "A Study on consumer buying behaviour towards branded apparels with reference to bangalore city" *International Journal of Advanced in Management, Technology and Engineering Science ISSN NO: 2249-7455*
4. **P. Mohanraj and S. Gopalakrishnan (2017)** "Purchase preferences towards apparel brands". *Vol.05 Issue-02, (February, 2017) ISSN: 2321-1784 International Journal in Management and Social Science*



A STUDY ON CUSTOMER SATISFACTION TOWARDS BISLERI DRINKING WATER WITH SPECIAL REFERENCE TO COIMBATORE CITY

Dr. S. Suguna

*Associate Professor, Department of Commerce with Professional Accounting
Dr. N.G.P Arts and Science College (Autonomous), Coimbatore*

Mr. Thangaraj.V.S

*III B.Com (Professional Accounting), Dr. N.G.P Arts and Science College (Autonomous)
Coimbatore*

ABSTRACT

Customer satisfaction is the most important term for any company to survive in this competitive world. The main objective of the study is to find out the customer satisfaction towards Bisleri drinking water. The samples 120 were selected among the customers of Bisleri in Coimbatore city. The major findings of the study are, the majority of the respondents buy Bisleri 1 liter petbottles. The customers preferred Bisleri water for the hygiene aspects and convenient package. It is found that customers are satisfied with the Bisleri drinking water.

KEYWORDS: *Bisleri, customer satisfaction, packaged drinking water.*

INTRODUCTION

The art of predetermining the wants and needs of the customer is so important for any company. The purpose of the study is to find out the consumer satisfaction towards Bisleri and to assess the association between demographic variables and consumer satisfaction towards Bisleri water. Data from existing research on customer satisfaction towards Bisleri was taken and an empirical research was undertaken to study the customer satisfaction.

STATEMENT OF THE PROBLEM

The customers are having several brands in choosing the packaged drinking water, and the variety of packaged drinking water is also like bottled, bubble top, can, and so on. But when the facet of brand influences the purchase there come the quality standard. Hence, a research has been carried out to study the customer's satisfaction level towards Bisleri package drinking water. Packaged drinking water is getting recognizable as the characteristic of handiness and quality has been assured.

SCOPE OF THE STUDY

- Though so many brands came as the competitor for Bisleri, Bisleri is sustaining its brand value by satisfying its customers.
- Thus it is important to study what made the customers want towards Bisleri and how they satisfied their customers
- The study helps to understand the factors, which influence the customers to purchase a particular brand and measuring the level of satisfaction towards Bisleri.

OBJECTIVES OF THE STUDY

- To know the level customer satisfaction towards the Bisleri drinking water.
- To study the factors influencing purchase of Bisleri drinking water.
- To understand the customers needs and wants regarding the Bisleri drinking water.

METHOD OF DATA COLLECTION

This study is based on both primary and secondary data.

**➤ Primary data**

In primary data, the data been collected through the questionnaire.

➤ Secondary data

The secondary data was collected by going through websites, marketing journals and articles.

RESEARCH METHODOLOGY**➤ Research design**

The descriptive research design was applied in the research methodology of the study.

➤ Sample size

Sample size taken in this study is 120.

➤ Tools used

The following are the tools which are used in this study to validate the data:

- Simple percentage analysis
- Likert scale analysis
- Rank analysis

REVIEW OF LITERATURE

K.VIJIYA VENKATESWAI(2016) in his study focused to find out the sources of awareness of consumers towards mineral water and the individual consumption of mineral water. He found that advertisement is the best source of information as all the respondents are aware of mineral water. Majority of the respondents spend up to Rs.500 per month towards mineral water, consume mineral water for the one to two years having monthly.

K.KOHILA (2019) made an attempt to study the future prospectus of mineral water besides finding out the leading brand in Chennai city. In the case of fast moving packages, it has been revealed that one-litre bottles are more in demand accounting for 60 per cent of sales as against 10 per cent of sales of two litre bottles. The fast moving and leading brand was identified as Bisleri due to its taste and creditability of the company. He remarked that safe and reliable water distribution can no longer be taken for granted not even in the most developed countries and the consumer is quite willing to pay more for quality taking into consideration his own need, and his family health.

ANALYSIS**TABLE SHOWING AWARENESS OF BISLERI DRINKING WATER BY THE RESPONDENTS**

S. No	Categories	No. of Respondents	Percentage (%)
1	Advertisement	24	20
2	Shopkeeper	27	22
3	Neighbour	30	25
4	Doctors	27	22
5	Friends & Relatives	9	8
6	Sales man	3	3
		120	100

(Source: primary data)

INTERPRETATION

The table shows that 25% of the people know about bisleri water from neighbours, 22% of the people knows from the shopkeeper and doctors, 20% of the people knows from advertisement, 8% of the

respondents knows from friends and relatives and 3% of the respondents knows from the sales man.

INFERENCE

Majority 25% of the people know about bisleri water from neighbours .

TABLE SHOWING RANKING FOR PREFERING PACKAGED DRINKING WATER BY THE RESPONDENTS

S.No	Particulars	1	2	3	4	5	Total	Rank
1	Quality	8(5)	15(4)	18(3)	23(2)	56(1)	252	1
2	Taste	1(5)	18(4)	22(3)	28(2)	51(1)	250	3
3	Price	5(5)	11(4)	27(3)	25(2)	52(1)	252	1
4	Easy to delivery	1(5)	13(4)	28(3)	29(2)	49(1)	248	4
5	Services	6(5)	11(4)	20(3)	23(2)	60(1)	240	5

(source: Primary data)

**INTERPRETATION**

From the above table it is understood that, quality and price is ranked 1, taste is ranked 3, easy to delivery is ranked 4 and services is ranked 5 by the respondents for preferring packaged drinking water.

INFERENCE

Quality and Price is ranked 1 by the respondents for preferring packaged drinking water.

TABLE SHOWING SATISFACTION OF RESPONDENTS TOWARDS PACKAGED DRINKING WATER

S.No	Factors		5	4	3	2	1	TOTAL	Likert Scale
	Likert Scale value (x)								
1	Availability of various quantities	f	68	34	16	1	1	120	4.3
		fx	340	136	48	2	1	527	
2	Relatively cheap pricing	f	56	36	23	3	2	120	4.17
		fx	280	144	69	6	2	501	
3	Attractiveness	f	62	32	22	2	2	120	4.25
		fx	310	128	66	4	2	510	
4	Quality of product	f	60	33	22	4	1	120	4.2
		fx	300	132	66	8	1	507	
5	Product design	f	60	32	22	2	4	120	4.18
		fx	300	128	66	4	4	502	

(Source: Primary data)

INTERPRETATION

The likert scale value is greater than the mid value (3), thus the respondents are satisfied with the factors.

INFERENCE

The respondents are satisfied with the factors.

FINDINGS**SIMPLE PERCENTAGE**

- Majority 66% of the respondents are male.
- Majority 40% of the respondents are in the group of below the age of 25 years.
- The majority 52% respondents are unmarried.
- Majority 38% of the respondents are in the family of 3 to 5 members.
- Majority 40% of the respondents educational qualification is postgraduate.
- Majority 33% of the respondents are self employed.
- Majority 53% of the respondents mode of income is monthly.
- Majority 30% of the respondents having monthly income of Rs.30,000 to 40,000.
- Majority 50% of respondents using bisleri drinking water occasionally
- Majority 25% of the people know about bisleri water from neighbours .
- Majority 33% of the people using bisleri water during travel
- The majority 71% of the respondents prefer bisleri water to use.
- Majority 28% of the people using Bisleri water for convenient package.

- The majority 42% of the respondents using bisleri water for more than 3 years.
- Majority 45% of the respondents buy 1 litre petbottles of bisleri water at a time.
- The majority 29% of the respondents purchase Bisleri water 16 to 20 times in a month .
- The majority 27% of the respondents spends 500 to 700 for purchasing Bisleri water for a month
- Majority 28% of the people prefer Bisleri water for nearness to residence.

RANK ANALYSIS

- Quality and Price is ranked 1 by the respondents for preferring packaged drinking water

LIKERT SCALE

- The respondents are satisfied with the factors.

SUGGESTIONS

The manufacturers of the packaged drinking water should concentrate on the perfect ingredients denote by the BIS as per the water board of India in their process of purification of the water. Proper care should be taken that supply is made regularly to the shops. The package of water bottles are more convenient to handle. Of all the advertisement, TV advertisement is highly popular than other medias. Hence producers should focus their attention on TV advertisement rather than other media.



CONCLUSION

It is found that customers are preferred quality and price in Bisleri packaged water. And most of the people prefer Bisleri water for nearness to their residence. It is concluded that customers are satisfied with Bisleri water. Hence it becomes evident that those brands that show importance to those aspects will sell more in the market and capture more number of customers. Customers will have in terms of quality and hygienic aspect because packaged water is a product on which these aspects are expected.

REFERENCE

1. **K.VIJAYA VENKATESWARI**, "Marketing of mineral water study on consumer and let outlets in Coimbatore city", M.Phil dissertation submitted to Bharathiar University, Coimbatore, 2016
2. **K.KOHILA**, "Future Prospectus of Mineral Water," MBA Project Report Submitted to Department of Management Studies, Madurai Kamarajar University, Madurai, 2019
3. **P.K SRIVASTAVA**, "A Study of Market Potential for Packaged Drinking Water in Hospital with reference to Aquafina", M.Phil Dissertation Submitted To Bharathiar University, Coimbatore, 2009
4. **M.ABIRAMI** "Mineral water or tap water- A systematic analysis of the literature concerning the question of microbial safety", 2019, Available at www.ncbi.nlm.nih.gov/pubmed/10800246



A STUDY ON CUSTOMER SATISFACTION TOWARDS FASTRACK WATCHES WITH REFERENCE OF COIMBATORE CITY

Mrs. P.Dhanya

*Assistant Professor, Department of Commerce with Professional Accounting,
Dr. N.G.P Arts and science college, Coimbatore*

N. Naveen Kumar

*Student of III B.com (PA), Department of Commerce with Professional Accounting,
Dr. N.G.P Arts and science college, Coimbatore*

ABSTRACT

Today fast track provides the young at heart a wide range of products. They put on pockets, belts, wallets and even wristbands from watches and sunglasses. Watches there are several collections among the fast track watches that can be found. Every collection refers to a certain theme that is present in that collection in each of the designs. The new collection means all the latest models that fast track is introducing, while there are the grunge, hip hop, neon, digital fashion, aluminum, color play, bikers, army and others, each with their distinct watch range.

INTRODUCTION

Customer preference is defined as a set of assumptions that focus on customer choices that result in different alternatives such as happiness, satisfaction or utility. The entire customer preference process results in an optimal choice. Customer preferences allow a customer to rank different bundles of goods according to levels of utility or that total satisfaction of consuming a good or service. It is important to understand that customer preference are not dependent upon customer income or prices. So, customer's capacity to buy goods does not reflect a customer's likes or dislikes.

The customer preference explains how a customer ranks a collection of goods or services or prefer one collection over another. This definition assumes that customer ranks goods or services by the amount of satisfaction or utility, afforded. Customer preference theory does not take the customer's income, good or service's or price or the customer's ability to

purchase the product or service. The customer preference assumes that the customer can choose consistently between or among goods and services. The customer must prefer one set of goods or services over others or treat all as equally beneficial. Consistency is an issue when the customer must consider more than two alternatives. Customer preference theory assumes that "more is better". This form of preference, monotonicity, has varying levels of strength. The underlying foundation of demand, therefore, is a model of how customers behave. The individual customer has a set of preference and values whose determination are outside the realm of economics. They are no doubt dependent upon culture, education and individual tastes. Among a plethora of other factors. The measure of these values in this model for a particular good is in terms of the real opportunity cost to the customer who purchases and customer the good. If individual purchases a particular good, then the opportunity cost of that purchase is the forgone goods the customer



could have bought instead. Customer preferences are defined as the subjective (individual) tastes, as measured by utility of various bundles of goods. They permit the customer to rank these bundles of goods according to the levels of utility they give the customer.

STATEMENT OF THE PROBLEM

Wrist watches has become an indispensable thing in common man's life. But, in current scenario the increase of technology and innovations most of the consumer's had switched over to the latest updates of innovations. The consumer's now-a-days they use mobile phones instead of watches. Though consumer's regret to use watches, the Fastrack watches has a standard sales than any other branded watches. Hence, the study is to determine and scrutinize the factors influencing the customers to prefer Fastrack watches even though there are more innovations and modern technologies.

OBJECTIVES OF THE STUDY

- To identify the consumers preference towards Fastrack watches with special reference to Coimbatore city.
- To study the level of satisfaction on Fastrack watch users in the study area.
- To ascertain the general problem faced by the consumers while using the Fastrack branded watch.
- To understand the importance of media in choosing the Fastrack branded watch.

SCOPE OF THE STUDY

The scope of the study is to identify the consumer's preference towards fastrack banded watches. It is aim to enlightening the company about different steps to be taken up to increase the share of fastrack in the market, with regard other competitors. And also to make company to provide better customer service. It also opens the various factors which can affect the purchase decision. Here our regional scope is limited up to Coimbatore city.

RESEARCH METHODOLOGY

Research design is a detailed blue print used to guide the research study towards its objective. The research design for the study is descriptive analytical in nature that is conducted among the users of Fastrack watches especially in Coimbatore city.

SOURCE OF DATA

The study includes both primary and secondary data that helped in systematic frame work of the study.

- Primary source of data which is collected for the first time. It is original data for the purpose of collection of primary data, questionnaire were filled by the respondents. The questionnaire comprises of closed ended.
- Secondary data was collected from books, journals and magazines. Periodical information from different websites was also for the study.

SAMPLING DESIGN

For the purpose of this study, the data was collected from 120 respondents by using convenience sampling technique.

SAMPLE SIZE

The sample size which is taken for the study is 136.

REVIEW OF LITERATURES

Dr.J. Malarvizhi, T. Chitra Devi (2018)The Objective is to study on the level of satisfaction among the customers and to evaluate the customer's opinion towards the Fastrack watches and suggest some improvements that can be helpful for the development of the organization. The research design adopted for this study is descriptive design. Data contains primary data and secondary data. Analysis is done on various perspective such as customer's perceptions, expectation of the customer's, opinion regarding the Fastrack watches.

K.Anitha, Dr.M. Uma Maheswari (2013) The focus of the present study is to gain knowledge about the different types of titan brand, factors influencing the consumers to prefer a particular brand and the problems faced by them on using such brands. For the purpose of obtaining the data, questionnaire method is used. Suitable tools have been exploited to obtain scientific evidence and further suggestions useful for the industry have also been presented.

Angelova.B(2011) Measuring customer satisfaction with service quality using American customer satisfaction model (ACSI Model International Journal of Academic Research in Business and Social Sciences October 2011.

Beneke.J, Hayworth.C, Hobson, R and Mia, Z(2012)Examining the effect of retail service quality dimensions on customer satisfaction and loyalty: The



case of the supermarket shopper. School of Management.

Lin, G. T. R., and Sun, C. C. (2010) Factors influencing satisfaction and loyalty in online shopping: an integrated model, Emerald publishing group ltd, Miles, G., & Cannon. (2011). Linking service to customer satisfaction: exploring the role of competitive strategy, International journal of operation and production management, Emerald group of publishing limited.

Turel and Serenko (2010) studied validation of American Customer Satisfaction Model in mobile telecommunication sector and found that there is a positive association between perceived customer expectations, perceived quality, value and satisfaction

and a negative link between satisfaction and customer complaints.

ANALYSIS AND INTERPRETATION

Analysis and interpretation are essential for usefulness and utility of resource findings analysis of data and interpretation in a general way involves a number of closely related operations, which are performed with the purpose of summarizing the collected data, organizing these in such manner that they answer the research questions.

- Simple Percentage analysis
- Likert scale analysis
- Ranking analysis

SIMPLE PERCENTAGE ANALYSIS

TABLE SHOWING THE REASON FOR SELECTING FASTRACK WATCHES OF RESPONDENTS

S.NO	REASONFOR SELECTING EASTRACK WATCHES	NO. OF RESPONDENTS	PERCENTAGE
1	Brand value	51	37
2	Style	54	40
3	Prestige symbol	24	18
4	Others	7	5
	Total	136	100

(Source: primary data)

INTERPRETATION

The above table shows that 37% of the respondents are selecting for brand value, 42% of the respondents are selecting for style, 16% of the

respondents are selecting for prestige symbol, 5% of the respondents are others.

Majority 42% of the respondents are selecting for style of watch.

LIKERT SCALE ANALYSIS

THE PURCHASE DECISION OF RESPONDENTS OF QUALITY FACTORS OF FAST TRACK WATCH

S.NO	FACTORS	NO.OF. RESPONDENTS	LIKERT SCALE VALUE(X)	TOTAL(FX)
1	Important	68	3	204
2	Neutral	46	2	92
3	Not important	22	1	22
	TOTAL	136		318

(Source: primary data)

INTERPRETATION

Likert scale = $\frac{\sum(Fx)}{\text{Total number of respondents}}$
 $= \frac{318}{136}$
 $= 2.338$

INFERENCE

Likert scale value is 2.338 which is greater than 2. So the respondents are important to the quality factor.

**RANK ANALYSIS****THE PREFERENCE OF RANKING FOR TYPES OF FAST TRACK WATCH OF THE RESPONDENTS**

S.NO	TYPES	RANK I	RANK II	RANK III	RANK IV	RANK V	TOTAL SCORE	RANK
1	Overall quality	21(5)	30(4)	14(3)	25(2)	46(1)	363	5
2	Battery	14(5)	28(4)	35(3)	26(2)	33(1)	372	4
3	Purchase experience	22(5)	40(4)	16(3)	30(2)	28(1)	403	2
4	Usage experience	15(5)	29(4)	36(3)	21(2)	35(1)	376	3
5	Warrenty	43(5)	22(4)	40(3)	19(2)	12(1)	473	1

*(Source: primary data)***INTERPRETATION**

The tale 4.3.1 shows that the out of 136 respondents, overall quality is in the rank 5, battery is in the rank 4, purchase experience is in the rank 2, usage experience is in the rank 3, warrenty is in the rank 1,

INFERENCE

If resulted that warrenty is in the rank 1 and it is influences the respondents to prefer warrenty

FINDING**PERCENTAGE ANALYSIS**

- Both men and females respondent's are not equal .
- The majority of the respondent are came from the age range of below 25.
- 72.5% of the respondent's where single.
- Most of the data was collected from students .
- Majority of the respondents use the FASTRACK brand.
- 29.2% of the respondents buy FASTRACK product for the price.
- Majority of the respondents like to buy in online.
- TITAN brand stands first in Analysis for Fastrackproduct.
- Most of the respondent like to spend premium price for the Fastrack product.
- 73.3% of the respondents are satisfied with Fastrack product.

RANK ANALYSIS

- "Advertisement" has been ranked as 1
- "Brand image" has been ranked as 2
- "Quality" has been ranked as 3
- "packaging" has been ranked as 4
- "celebrity" has been ranked as 5.

SUGGESTIONS

After analyzing utterly the data and scrutinized the finding , the research offers the following suggestions for consideration.

- Most of the respondents are satisfied with the FASTRACK productwith their wide range of products, quality, price in an effective way .
- The respondents are interested in the premium products of fastrack product.
- Strong competitor and available of subtle products in wide range is big deal .
- Making innovation and innovative ,market friendly products can bring more profits and customer satisfaction.

CONCLUSION

Thus from the study of Fastrack it can be understood that being so large and so extensive in brands it has allocated equal importance to each of its product and services. Moreover being so evident in each of its segment which is widely used by Indian as well as world wide customers; FASTRACK is not only focusing on major brands but also on those brands which are not performing well and new products are



brought into market by viewing the importance of Innovation in this changing environment. As bees are treated as social insects, committed to prioritising the colony's needs and working together. Such team work and a passionate commitment to achieve a shared goal is what helps Fastrack(TITAN) create milestones.

REFERENCE

1. **Dr.J. Malarvizhi, T. Chitra Devi (2018)***The Objective is to study on the level of satisfaction among the customers and to evaluate the customer's opinion towards the Fastrack watches and suggest some improvements that can be helpful for the development of the organization.*
2. **S. Kubendran, M.V. Deepak Rajagopal (2018)***The focus of the present study is to gain knowledge about the different types of titan brand, factors influencing the consumers to prefer a particular brand and the problems faced by them on using such brands.*
3. **Angelova.B(2011)** *Measuring customer satisfaction with service quality using American customer satisfaction model (ACSI Model International Journal of Academic Research in Business and Social Sciences October 2011.*
4. **Beneke.J, Hayworth.C, Hobson, R and Mia, Z(2012)***Examining the effect of retail service quality dimensions on customer satisfaction and loyalty: The case of the supermarket shopper. School of Management.*
5. **Lin, G. T. R., and Sun, C. C. (2010)** *Factors influencing satisfaction and loyalty in online shopping: an integrated model, Emerald publishing group ltd, Miles, G., & Cannon. (2011).*
6. **Angelova.B(2011)** *Measuring customer satisfaction with service quality using American customer satisfaction model (ACSI Model International Journal of Academic Research in Business and Social Sciences October 2011.*

WEBSITES

- ✓ Shodhganga.inflibnet.ac.in
- ✓ www.indianjournals.com
- ✓ www.iosrjournals.org
- ✓ Info.dogpile.com



AN IMPROVED DESIGN AND CONSTRUCTION WITH PERFORMANCE EVALUATION OF A MELON SEEDS SHELLER WITH A CONTINUOUS SEPARATOR

Adeleke M.B¹

¹Department of Mechanical Engineering, Moshood Abiola Polytechnic, Abeokuta, Ogun State, Nigeria

Orelaja O.A^{2*}

²Department of Mechanical Engineering, Moshood Abiola Polytechnic, Abeokuta, Ogun State, Nigeria

** Corresponding Author: (Orelaja O.A)*

Article DOI: <https://doi.org/10.36713/epra5771>

ABSTRACT

An improved designed and constructed melon seed sheller with continuous separator comprises of electric motors, hopper, shelling, and separator units for separating melon seed from its shell, was developed. This machine which was fabricated using locally sourced standard materials by eliminating the drudgery involved in the melon kernel separation. As we know that melon seed is a vital oil seed that is mostly used in food industries. Shelling of this crop is a problem due to the stress and time that is involved, prior to its usage. In order to address these challenges associated with shelling and separating the melon from its kernel, an improved design of melon shelling machine of melon seeds for both commercial and a small scale was presented and evaluated in this research work. Parameters evaluated include shelling efficiency, percentage seed shelled, and output volume with time and general machine capacity. The machine was constructed using locally available materials and consists of a hopper, frame, shelling and cleaning unit, chutes and prime mover. Shelling speeds of the machine and seed moisture content of melon affects the rate, efficiency and percentage seed damage. Adopting this design concept is recommended because it minimizes seed breakage during manual shelling, it also enhanced hygiene as human direct contact with the seed during shelling is reduced.

KEY WORDS: *Improved design, melon seed, melon kernel, performance evaluation, efficiency.*

1.0 INTRODUCTION

Melon having a botanical name (*Citrullus lanatus* ssp *colocynthisoides*), it bears its fruits in pods with thousands of seeds embedded in this pod. The harvested process of melon pods are classified to three major edible products, (i) melon kernel, (ii) melon flour and (iii) melon oil. The processing stages are the field and factory/house operations. Melon seeds are extracted from its pod after harvest in farm/field. The field process involves depodding of the fruit from the hub to expose its internal content for proper fermentation and separation of the seeds from the fermented pulp by washing/sieving and drying of the seeds. Dehusking (shelling) of external shell of the melon seed from its cotyledon/kernel, separation of its shell and kernel is a continuous factory operations system according to [1-2]. This operation can be carried out in the field or at the storage environment [3]. Melon is mostly called, „Egusi“ by Yorubas, „Agusi“ by Hausas and, „Ogil“ by Igbo people of Nigeria [4]. The main types of melon found in Nigeria



are Bara, Serewe, Sofin, variety “E” and “N” types [5]. According to [6] the melon seed can be grounded into thick paste for making soup or stew as well as serving as a raw material in the production of margarine, salad, “robo cake”, baby food, livestock feeds, local pomade, soap and its shells can be used as poultry litter. Despite the large productivity and nutritional potentials of this crop, there has been a hindrance to the use of melon for large scale production of oil and protein sources. This is as a result of inability to shell melon to meet the capacity required for industrial purposes. The seed called Shelling of melon as a unit operation is therefore an important step towards the processing of melon to its finished products. Most farmers, who cultivate this crop both in Nigeria and West Africa alike, encounter several processing challenges of shelling this crop, as it requires a relatively high expenditure and human manual shelling energy which is a major concern. The inability to effectively shell melon in order to meet the requisite volume necessary for industrial utilization, has been a hindrance to its use for large scale production of various commodities [5][7]. It is our belief that the conventional or manual method of shelling melon is not good enough and cannot meet up with the demand, due to inefficient, tedious and time consuming, thus limiting the availability of their products in the market [4][8]. However, researches have shown that melon is an excellent source of protein with higher levels of amino acids than soybean meal. It is also used as an ingredient for making soup/stew, melon bread/cake, etc when processed into flour while its oil is medicinal constituting a raw material for production of pomade, soap, margarine etc. The two by-products of the factory stage of melon processing- the shell and residual chaff are also of economic value. The chaff is a source of protein for livestock feed and also for producing a local melon snack known as “ROBO” while the shell is an excellent poultry litter is also used for reclaiming crude oil polluted soil [5][9].

There are several breakthrough recorded in the design and development of mechanized systems for factory melon processing operations such as melon shellers, burr mills, blenders and melon seed oil expeller of various sizes are acknowledged [5][9][10][11][12]. However, high melon seed/kernel breakage inefficacy constitutes the major consistent limitation of melon seed shellers. According to [11], he developed an integrated melon shelling and cleaning machine, but the efficiency is lower than what is expected. An Improved Design and Construction of a Melon seeds sheller with a continuous separator for processing melon is highly required to meet the people’s demand with tremendous volume within a short time. This is because freshly shelled melon tastes has a better than those that have been dehusked for a longer period of time. Melon kernel easily absorbs moisture and consequently ferments at a high rate than the undehusked seed as stated by [13]. According to [14], he said crushed melon kernels are easily susceptible to deterioration which affects the taste consequently. High volume of melon seed/kernel breakage associated with the existing melon shellers is due to the inability to control the speed of the shelling machine with respect to the various melon species (bara, serewe, sofin etc). Also, apart from the high set up cost of using individual stand-alone shelling, separation milling, discharging and reloading of processing materials amongst these machines are seen in the existing melon seed processing technologies which are stressful and unhygienic for human to consume. In order to reduce the set up cost, drudgery, losses due to melon kernel breakage as well as improve hygiene in melon seed processing, an improved design and construction of a melon seeds sheller with a continuous separator was developed to save time in the production sector.

In addition, with the prevalence of the erratic power supply, which is synonymous with Nigeria, it is important to look for other means of powering equipment, we therefore, employed fuel-powered sheller which is a better choice and has advantages over the electrical powered one due to non-reliance on electricity. Different scholars have worked on the design and development of shellers [15][16][17]. But not much work has been done in the literatures on the design and construction of a mechanized fuel-powered melon sheller with a continuous separator. Therefore, there is a need for a more cost effective, simple, friendly, hygienic and technologically feasible system for shelling melon. However, the main objectives of this experimental work are to produce an improved design and construct a fuel powered melon sheller with a continuous separator and to evaluate the performance of this machine.

2.0 MATERIALS AND METHODOLOGY

2.1 Materials

The materials used for the construction of this improved design and construction of a melon seeds sheller and continuous separator include: mild steel, ball bearings, angle iron, static disc, electrode, single and double groove pulley, shaft and belt. The part drawing of the melon sheller showing all the internal component of the machine is as shown in Figure 1.

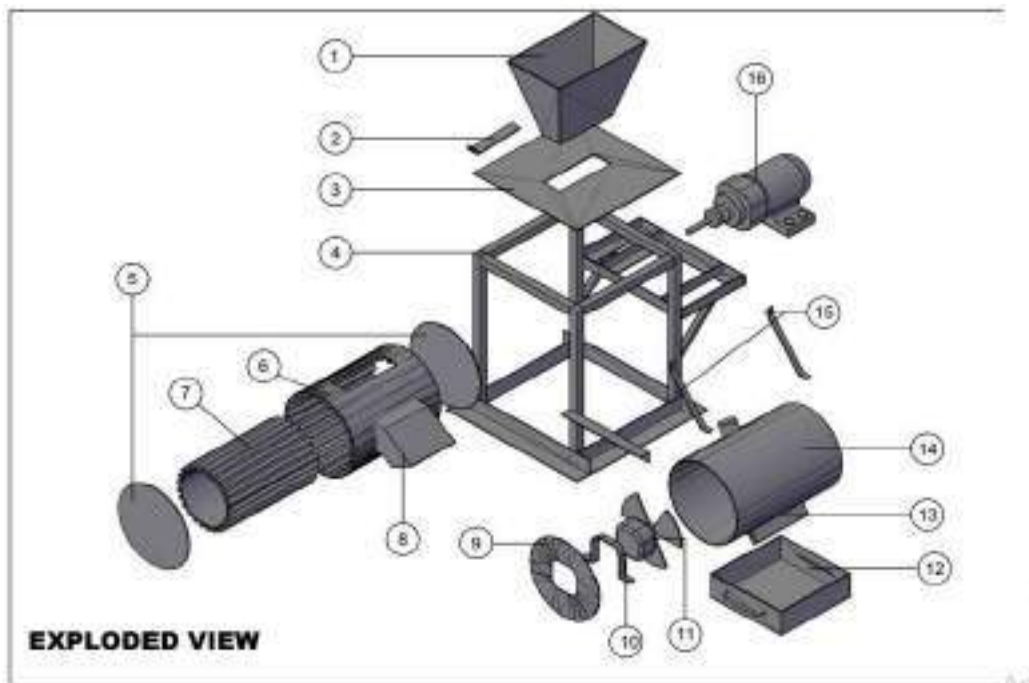

Figure 1 Sketch and line diagram of the melon sheller : 1 – Hopper; 2 – sight glass; Pulley; 3 – Frame cover; 4 –Housing frame; 5 – Disc cover; 6- Sheller ; 7- Sheller; 8- Outlet for shelled melon for melon; 9- Blower guide; 10- Guide; 11- Fan; 12- Outlet plate; 13- Blower outlet; 14-Blower; 15- Hub support; 16- Electric motor .

2.2 Construction and description of the machine

The Auto-Cad shaded view showing all the views of the constructed melon sheller was shown in Figure 2. Locally available, but quality materials (mild steel, angle iron, pulleys, shaft, belts and motor) which produce the desired objective at minimum cost were used. The machine consists of the hopper, shelling unit (which consists of rotating disc and static disc), the frame, the cleaning unit and chutes. To improve the free flow of seeds into the shelling unit, the conical shaped hopper was fabricated using mild steel into a height of 220 mm, upper radius of 250 mm and lower radius of 80 mm and inclined at an angle of 115° . The shelling unit consists of the rotating and static discs,

vanes and the shelling drum. The outer part of the rotating disc is lined with flat metal blades ($\frac{3}{4}$ inch) of 50 mm length were welded at an angle of 75° , and were arranged side by side with a distance of 9mm between the blades, along the diameter (180 mm) of the disc, forming vane slots at the edges of the rotating disc. The static disc consists of flat metal rods of 150 mm length, arranged side by side and welded at a distance of 10 mm to each other at an angle of 60° along the walls of the fixed drum which formed spikes. The frame which is the support on which the whole unit rests, was made from angle iron into a rectangular of size 1120 mm \times 300 mm \times 750mm high.

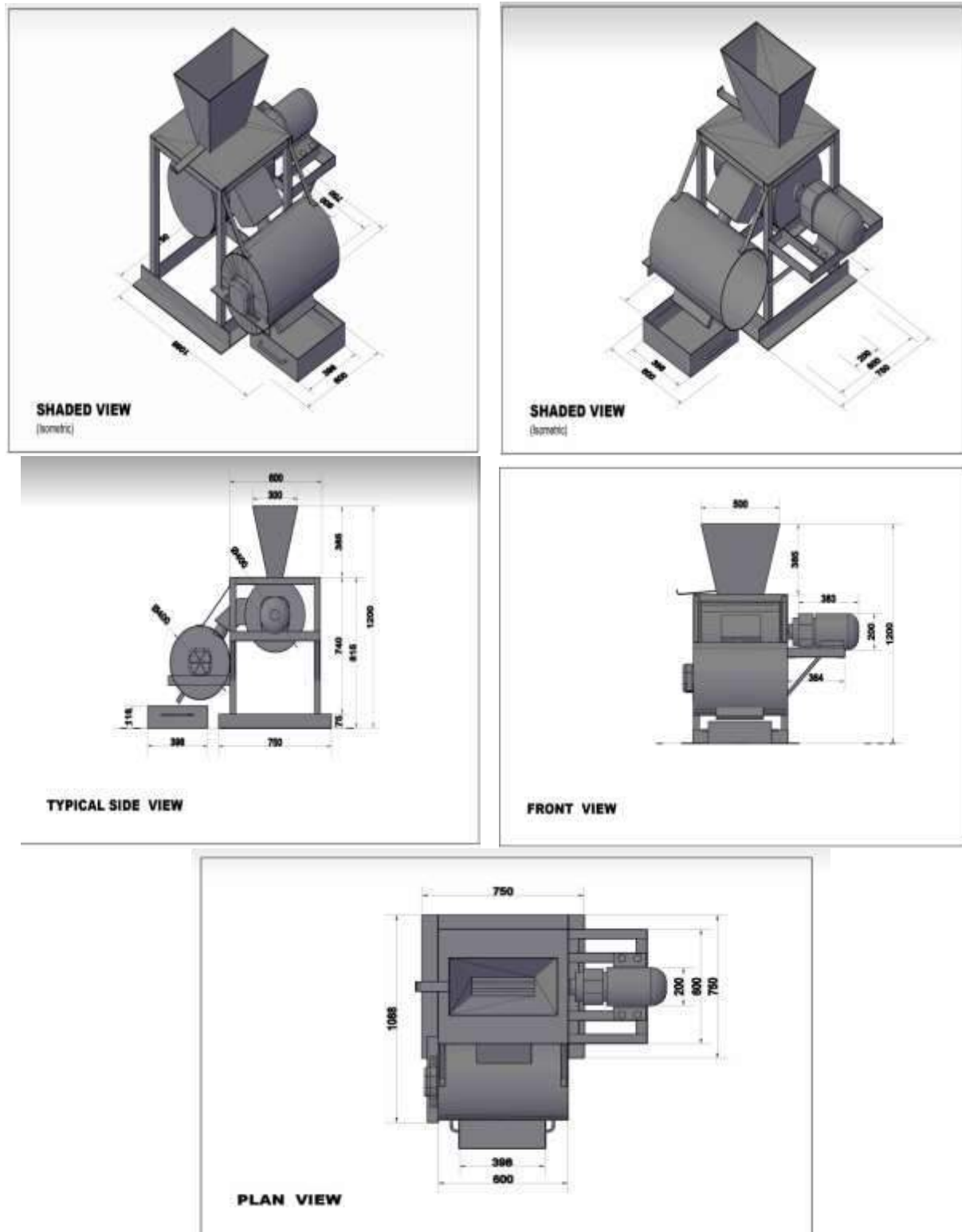

Figure 2 Showing the Auto-Cad shaded view of the constructed melon sheller



2.3. Design considerations

This machine was designed after a detailed experimental analysis of the results obtained from the previously made melon shelling machines, the lapses and their inefficiency was observed and noted so as to ensure that our design and construction was based on an improved design. A machine design should not be only technically good and have a precise operating system, but it should be capable of performing the purpose of the proposed application. It is however

expedient that a melon sheller apart from effectively performing its proposed application, it should also satisfy design and process requirement throughout its service life and must be durable and hygiene. The following factors were also considered in the design of the melon seed sheller: (i) availability of raw materials for construction; (ii) mechanical properties of the material; (iii) cost (iv) power requirement; (iv) ease of fabrication, assembling and dismantling. The pictorial view of the assembled machine is shown in figure 3.



Figure 3 Showing the pictorial view of the assembled melon shelling machine

2.4 Design computations

The significant properties of melon seed influenced the basic design of this machine. Basic considerations were given to the design for the capacity and size of the machine, power requirement, speed of the pulley, length of the belt, diameter of the shaft.

A. Power Transmission Requirement for Shelling

The total power required for shelling was calculated using the equation as stated by [20] and as cited by [21].

$P_t = P_{inner\ drum} + P_{shaft} + P_{shelling} \dots\dots\dots (1)$

$P_{shelling}$ is negligible since seeds are not resident in sheller but flow through in pieces.

Therefore, $P_T = P_{inner\ drum} + P_{shaft} \dots\dots\dots (2)$

But the shaft and inner drum are welded together,

So, $P_T = P_{inner\ drum} \dots\dots\dots (3)$

with shaft,

$P_{inner\ drum\ with\ shaft} = T_{inner\ drum\ with\ shaft} \times V_{inner\ drum} \dots\dots\dots (4)$

with shaft,

$V_{inner\ drum\ with\ shaft} = \frac{2\pi N}{60} m/s \dots\dots\dots (5)$

$T_{inner\ drum\ with\ shaft}$ is the torque (Nm) N = is the number of revolution per minute of the inner drum with shaft =400 rpm

$T_{inner\ drum\ with\ shaft} = mass \times acceleration\ due\ to\ gravity \times radial\ distance \dots\dots\dots (6)$

But Mass inner drum with shaft = 5kg,



Acceleration due to gravity = 10m/s^2

Radial distance = 0.15m

$T_{inner\ drum\ with\ shaft} = 5 \times 10 \times 0.15 = 7.5\text{Nm}$

$P_{inner\ drum\ with\ shaft} = 7.5 \times \frac{3.142 \times 400}{60 \times 1000} = 0.3142\text{KW} = 0.4214\text{Hp}$

Using a power factor of 1.5, power required is 0.6321Hp , therefore an electric motor of 1Hp is selected to power the inner drum with shaft and shell the seeds.

B. Analysis of Driven And Driving Pulley

Let:

N_1 = Revolution per minutes of driving pulley

N_2 = Revolution per minutes of driven pulley

D_1 = Diameter of driving pulley

D_2 = Diameter of driven pulley

V_1 = Speed in (m/s) of driving pulley

V_2 = Speed in (m/s) of driven pulley

The diameter of driven pulley selected,

$D_2 = 45\text{mm}$

The ratio of the driven pulley outer diameter to that of the driving pulley outer diameter is rated as 3.5:1

From the equation (7); $N_1 D_1 = N_2 D_2$ i.e $N_1 / N_2 = 3.5 / 1$ (7)

Therefore $N_1 = 3.5 N_2$ (8)

But $N_1 = 1400$ rpm as seen on 1Hp electric motor

$N_2 = N_1 / 3.5 = 1400 / 3.5 = 400\text{rpm}$ (9)

Again from the equation (9);

$N_1 D_1 = N_2 D_2$ (10)

$D_2 = N_1 D_1 / N_2 = 1400 \times 45 / 400 = 157.5\text{mm}$

To Obtain Speed of Driving and Driven Pulley

$V_1 = \pi N_1 D_1 / 60 = 3.142 \times 1400 \times 45 / 60 = 3299.1\text{mm/s} = 3.299\text{m/s}$ (11)

$V_2 = \pi N_2 D_2 / 60 = 3.142 \times 400 \times 157.5 / 60 = 3299.1\text{mm/s} = 3.299\text{m/s}$ (12)

Which implies that there is no belt slip since $V_1 = V_2 = 3.299\text{m/s}$

The angle of lap (Θ) of each of the drives was computed as 180° (3.14rad), using Equation (13) while the belts' speed for the electric motor/speed reducer and speed reducer conveyor drives were determined as 9.42m/s and 0.16m/s respectively using Equation (14)

$\Theta = 180 - [2 \sin^{-1} (D_2 - D_1) / 2C]$ (13)

$V = \pi \frac{N_2 D_2}{60}$ (14)

Tensions on the tight side, /slack side of the belts for electric motor/speed reducer and speed reducer/paddle drives were determined as $160.52\text{N}/8.85\text{N}$ and $170.10\text{N}/9.37\text{N}$ respectively from equation (15), (16) (17) and (18).

$T_j = T_{max} - T_c$ (15)

$\tau_{max} = \sigma a$ (16)

$\tau_c = m v^2$ (17)

$2.3 \log \tau_i / \tau_j = \tau \theta \csc \beta$ (18)

Where T_{max} and T_c are the respective maximum and centrifugal tension of the belts while the groove angle, β , coefficient of friction between the pulleys and the belts, μ , maximum safe stress, σ , mass per unit length, m and the cross sectional area, a , of the belts were obtained from IS: 2494-1974 standard [22] as 0.3 , 190 , 2.1N/mm^2 , 0.108kg/m and 81mm^2 respectively. The result of this analysis indicated 6.26mm , 17.4377mm , and 15.811mm as the minimum diameters required of shelling drum, auger and paddle conveyor shafts respectively thus, standard



6.5mm, 18 mm, 16mm and diameter shafts were consequently selected for the respective shaft. The Figure 4 and Figure 5 below shows the force analysis of the shelling unit and the main driving shaft.

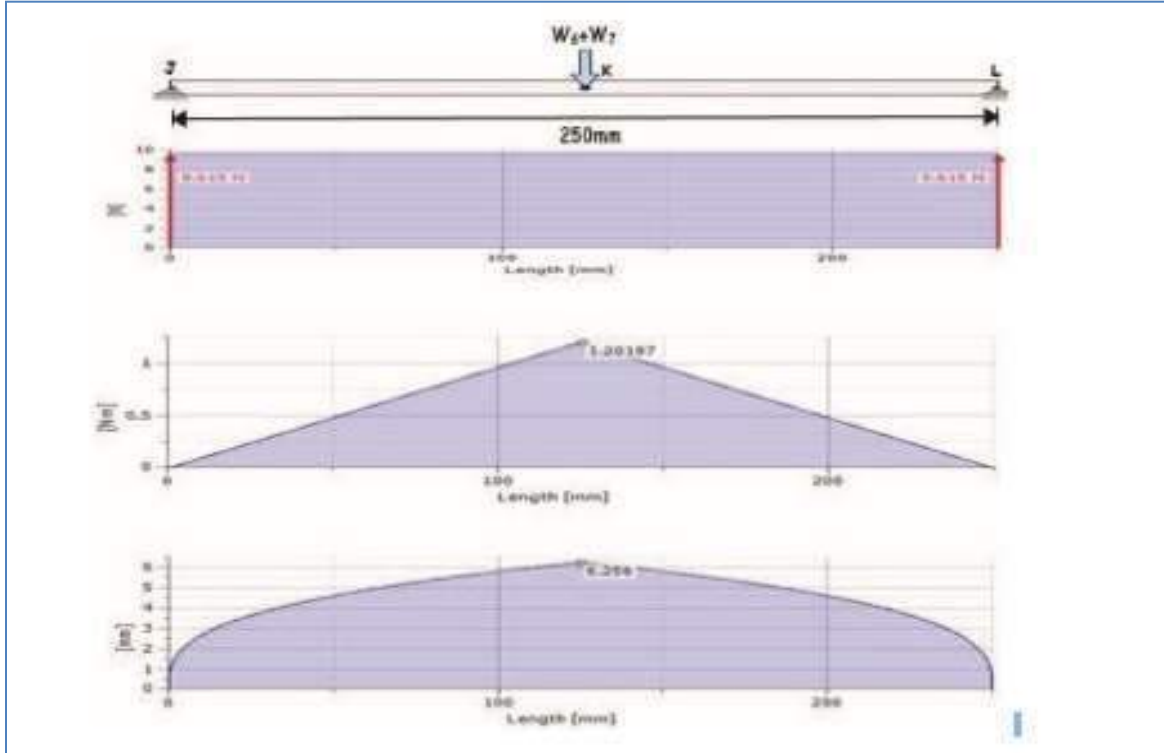

Figure 4 Force Analysis of the Shelling Unit

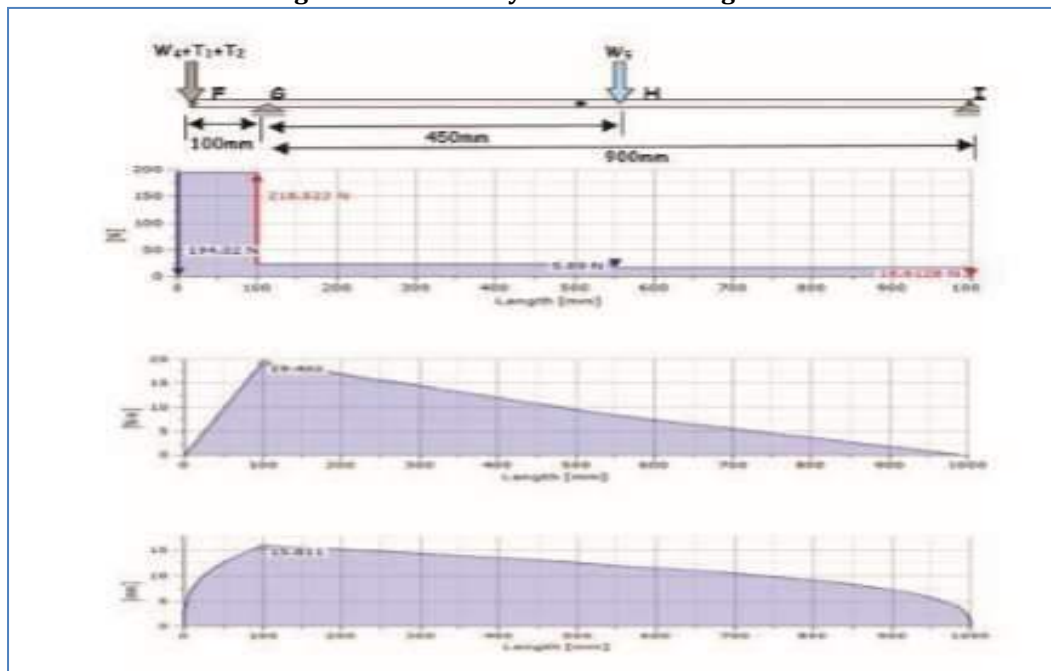

Figure 5. Force Analysis of the Main Driving Shaft



C. Analysis of the Weight Capacities of the Shelling Unit

The volume capacity of the shelling unit, depends on the volume of the hopper; that of the separation chamber depends on the volume of the U-trough as well as the volume occupied by the paddle shaft/paddles integrated assembly while that of the press depends on the volume of the press barrel, auger membrane, helix and cone. The weight capacities were thus derived from the weight-density-volume relationship.

$$W = \rho v g \quad \dots\dots\dots (19)$$

Where ρ = density, v = volume and g = acceleration due to gravity (9.8m/s^2).

Considering 94% head space for the separation chamber and 25% head space for the shelling unit, the effective weight capacities of the shelling unit and separation chamber, were determined as 5.89 N and 5.89 from Equation (2), (3), (4) and (5) respectively.

$$W_1 = 2.45 H \rho_m (L_t W_t + L_b W_b + \sqrt{L_t W_t L_b W_b}) \quad \dots\dots\dots (20)$$

$$W_3 = 7.36 \rho_m \left(\frac{1}{2} \pi r_3^2 l_3 - [\pi r_p^2 l_p + n(l_f b_f h_f + l_1 b_1 h_1)] \right) \quad \dots\dots\dots (21)$$

$$W_3 = 7.36 \rho_k \left(\pi r_c^2 l_c - \left[\pi r_a^2 l_a + 2\pi^2 r_h^2 \sqrt{R^2 + \left(\frac{Z}{N}\right)^2} + \frac{1}{3} \pi (r_b^2 h_b - r_t^2 h_t) \right] \right) \quad \dots\dots\dots (22)$$

Where and are the respective bulk densities of unshelled melon and melon cotyledon at moisture content between 9.53-24.08% (R Abu et al, 2007); L_t (0.3m), L_b (0.1m), L_a (0.8m), L_p (0.8m), l_a (0.04m), l_f (0.04m), l_h (0.4m) and l_a (0.4m) constitute the respective lengths of the top aperture of the hopper, base aperture of the hopper, separation trough, paddle shaft membrane, leather pad, flat bar, casing and auger membrane; W_t (0.3m), W_b (0.08m), b_1 (0.005m) and b_f (0.003m) are the respective widths of the hopper's top aperture, hopper's base aperture, flat bar and leather pads; r_a (0.125m), r_b (0.0085m), r_a (0.014m), r_c (0.0425m), r_h (0.005m), R (0.045m), r_b (0.0425m), and r_t (0.02m) are the radius of the separation trough, paddle shaft membrane, auger membrane, barrel, rod used in forming the helix, helix, base of the cone frustum and top of the cone frustum respectively; h_f (0.03m), H (0.15m), h_1 (0.03m), Z (0.09m), h_b (0.08m) and $h_t = 0.01\text{m}$ are the respective heights of the leather pad, hopper, flat bar, helix, complete cone and cone frustum while the number of paddles, n and revolutions of helix formed, N are 24 and 5 respectively.

2.5 Selection of Electric Motor

The power, required for the operation of the shelling unit was determined as 815.74W (1.09 HP) using equations (15),(16), (17),(18),(19),(20) and(21) by (Khurmi and Gupta,2005).

$$P_1 = T \omega \quad \dots\dots\dots (23)$$

$$T = I \alpha \quad \dots\dots\dots (24)$$

$$\alpha = \omega^2 r \quad \dots\dots\dots (25)$$

$$I = m r^2 \quad \dots\dots\dots (26)$$

The mass of the shelling drum, m ; radius of the shelling drum from the axis of rotation, r and design speed of cylindrical drum, ω are 1.35kg, 85mm and 99.48 rad/s (950rpm) respectively. This is represented by equation (27) as stated by Khurmi and Gupta, (2005),

$$P = (T_i - T_o) V \quad \dots\dots\dots (27)$$

Taking the load factor of electric motor, as 0.75, 1.5 HP and 3HP electric motors were selected for the operation of the shelling and separating chamber/press respectively.

3.0 EVALUATION OF PERFORMANCE ANALYSIS

The consequence of the effect of moisture content and shelling speed on melon dehusking as well as paddle speed, blow dryer speed and heat on shell/kernel separation were first examined. Thereafter, the extraction efficiency and the milling capacity were determined. The melon seeds used were procured from Omid market in Abeokuta, Ogun state, Nigeria. From the first test, the moisture content and shelling speed at five levels were used. Moisture content determination was carried out using ASAE standard and S.352 (ASAE, 1982).The shelling speed was varied by regulating the gasoline engine speed while different moisture levels were achieved by removing a known quantity of the seeds periodically from a lot that have been soaked in water and dried at varying room temperature. The initial moisture content of the seed was first used at five different inner drum speeds of 850, 950, 1000 and 1200 rpm.



Thereafter, the shelling efficiency, and percentage seed damage, were evaluated using Equations (28) and (29) respectively.

$$\eta_s = \left\{ \frac{(m_{sw} + m_{sb})}{m_c} \times 100 \right\} \dots\dots\dots (28)$$

$$\eta_b = \left\{ \frac{(m_{wb} + m_{sb})}{m_c} \times 100 \right\} \dots\dots\dots (29)$$

Where m_{sw} , m_{sb} , m_{wb} , m_c are the masses of seeds shelled (unbroken), unshelled seeds but broken, seeds shelled but broken and seeds put into the machine respectively. Secondly, five different trials were carried out in which the speed of paddle conveyor was operated at 20, 24, 30, 35 and 50 rpm and the blow dryer at the two speed and heat settings of 1000-1200 rpm and 1500-1700W respectively. The paddle conveyor speed was varied by changing the diameter of the driven pulley. In each trial, a known mass of unshelled melon, m_{us} at the moisture content and shelling speed obtained from the first experiment was introduced into the shelling unit and the time taken to dehull and separate the kernel/shell mix, was noted using a stop watch. Thereafter, the mass of melon kernel/seed received at the chaff outlet, m_s as well as the mass of chaff received at the kernel outlet, t_s were recorded as per each run and the separation efficiency, η_p (%) and separation capacity, S_c (kg/h) defined as the quantity of kernels cleaned per unit time were evaluated using equations (30) and (31) respectively.

$$\eta_p = \frac{m_c}{m_c + m_s} \dots\dots\dots (30)$$

$$S_c = \frac{m_c}{t_s} \text{ (Kg/h)} \dots\dots\dots (31)$$

4.0 RESULTS AND DISCUSSION

Results in (Fig. 6 and 7) show that shelling efficiency increased as the moisture level and shelling drum speed increased from 5.2% to 9.7% and 850 to 950 rpm respectively but decreased with further increase in both shelling drum speed and moisture level while the percentage seed damage decreased with increase in moisture level but show marked increase with increase in the shelling drum speed. Table 1 also shows the result of shelling test operation.

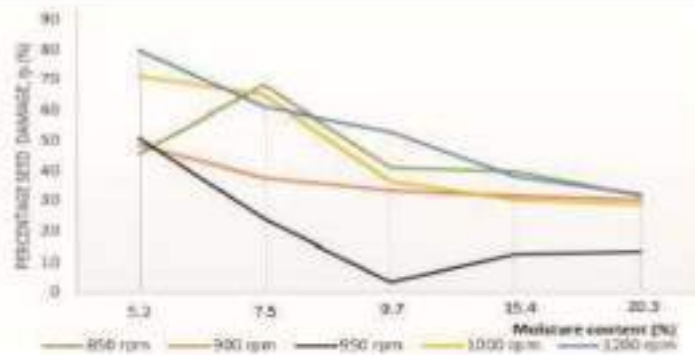

Figure 6. Effect of melon seed moisture content on seed/kernel breakage

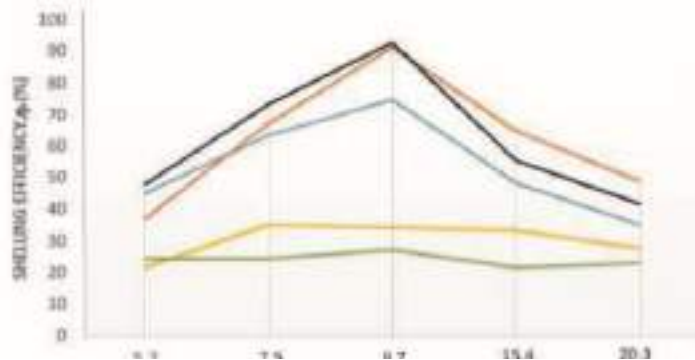

Figure 7. Effect of melon seed moisture content on shelling efficiency.

**Table 1. Result of Shelling Test Operation**

S/N	Weight of dry seed to be shelled(gm)	Weight of completely shelled seed(gm)	Weight of unshelled seeds (gm)	Weight of partially shelled and broken seed(gm)	Weight of crushed seeds (gm)	Efficiency (%)
1	70	60.9	5.6	3.0	0.5	87.0
2	140	131.6	5.0	3.0	0.4	92.0
3	210	203.0	4.0	2.7	0.3	93.7
4	280	273.7	4.0	2.0	0.3	97.5
5	350	344.4	3.5	1.8	0.3	94.4

$$\text{Average percentage performance} = (87.0 + 92.0 + 93.7 + 97.5 + 94.4) / 5 = 92.92\%$$

This totally confirmed that the efficiency of this improved continuous shelling and cleaning machine is very good.

5.0 CONCLUSION

This melon shelling and cleaning machine was made from locally available materials, the gasoline powered melon seed sheller was designed constructed and evaluated in this study. Results obtained showed that the machine can effectively shell melon seeds and that seed moisture contents and the speed of the shelling machine affected the performance indicators. The shelling efficiency increases with an increase in moisture content and decrease in shelling speed, it can be conveniently operated with little or no technical skill. Individuals can acquire it for domestic use and melon local farmers as well as medium scale industries involved in melon shelling can also make use of the machine since it does not require high skill labour. The average percentage performance of the melon shelling machine was found to be 92.92%. The average percentage of unshelled melon seeds plus crushed melon seeds was 5.22%. The production cost was minimal which is cheap compared to the cost of the imported ones available in the market.

SOURCES OF FUNDING

This research is fully funded by Tertiary Education Trust Fund grant (Tetfund 2016).

CONFLICT OF INTEREST

The author has declared that no competing interests exist.

ACKNOWLEDGMENT

None.

REFERENCES

1. Samaila R.S. and Chukwu O. (2014). Development of a Motorised Egusi Melon Seeds Oil Expeller. *Journal of Agricultural Engineering and Technology (JAET)*, Volume 22, No. 2, pp. 13-25
2. Tuhin Das. (2015). <http://www.Onlyfoods.net/egusi.html>. Assessed 25/9/2015.
3. Nwakire JN, Ugwuishiwu BO, Ohagwu CJ (2011) Design, construction and performance analysis of a maize thresher for rural dweller. *Nigerian Journal of Technology* 30: 49-51.
4. Prahan RC, Naik SN, Bhatnagar N, Vijay VK (2010) Design, development and testing of hand-operated decorticator for *Jatropha* fruit. *Applied Energy* 87: 762-768.
5. Adekunle AS, Ohijeagbon IO, Olusegun HD (2009) Development and performance evaluation of manually and motorized operated melon shelling machine using impact technique. *Journal of Engineering Science and Technology Review* 2: 12-1.
6. Odigboh EU (1979) Impact egusi shelling machine. *Transaction of the ASAE* 22: 1264-1269.
7. Sobowale SS, Adebisi JA, Adebo OA (2015) Design, Construction and Performance Evaluation of a Melon Seeds Sheller. *J Food Process Technol* 6: 463. doi:10.4172/2157-7110.1000463.



8. James KM, Umogbai V, Itodo IN (2011) Development and evaluation of a melon shelling and cleaning machine. *Journal of Emerging Trends in Engineering and Applied Sciences* 2: 383-388.
9. Nwakire JN, Ugwuishiwu BO, Ohagwu CJ (2011) Design, construction and performance analysis of a maize thresher for rural dweller. *Nigerian Journal of Technology* 30: 49-51.
10. Shittu SK, Ndrika VIO (2012) Development and performance tests of a melon (egusi) seed shelling machine. *Agricultural Engineering International* 14: 1-11.
11. Kassim M.J., Victor U. and Isaac I. (2011). Development and Evaluation of a Melon Shelling and Cleaning Machine. *Journal of Emerging Trends in Engineering and Applied Sciences, (JETEAS), Vol. 2 (3), pp.383-388.*
12. Samaila R.S. and Chukwu O. (2014). Development of a Motorised Egusi Melon Seeds Oil Expeller. *Journal of Agricultural Engineering and Technology (JAET), Volume 22, No. 2, pp. 13-25.*
13. Tuhin Das. (2015). <http://www.Onlyfoods.net/egusi.html>. Assessed 25/9/2015.
14. Oriaku E.C., Agulanna C.N., and Nwannewuihe H.U. (2013). Comparative Performance Analysis of Melon (*Colocynthis Citrullus L.*) De-Husking and Separation Machines by Principles of Impact and Attrition. *International Journal of Multidisciplinary Sciences and Engineering, Vol. 4, No. 7, Pp.53-59.*
15. Fashina AB (1971) The design and development of a melon sheller. University of Ife, Nigeria.
16. Odigboh EU (1979) Impact egusi shelling machine. *Transaction of the ASAE* 22: 1264-1269.
17. Fadamoro I (1999) Design and Construction of a manually operated melon sheller. University of Ilorin, Nigeria.
18. Fashina AB (1971) The design and development of a melon sheller. University of Ife, Nigeria.
19. Khurmi, RS, Gupta JK (2004) *Theory of Machines*, Eurasia Publishing House, New Delhi, India.
20. Oja, P : Constructuion of melon shelling machine, Unpublished B.Sc. Report. Dept. of Agricultural Engineering, University of Ilorin, Nigeria, 1991.
21. Akintunde, B.O., Oyawale, F.A., Tunde-Akintunde, T.Y: Design and fabrication of a cassava peeling machine. *Nigerian Food Journal Vol. 23 pg. 231-238. 2005.*
22. Fadamoro I (1999) Design and Construction of a manually operated melon sheller. University of Ilorin, Nigeria.



A STUDY ON CONSUMER PREFERENCE AND SATISFACTION TOWARDS DELL LAPTOPS IN COIMBATORE CITY

Dr.K. Vanaja

*Professor and Head, Department of commerce with professional accounting,
Dr. N.G.P Arts and science college, Coimbatore*

Anbarasu.U

*Student of III B.com (PA), Department of commerce with professional accounting,
Dr. N.G.P Arts and science college, Coimbatore*

ABSTRACT

Michael Dell founded Dell computer corporation, PC's limited, in 1984 while a student at the University of Texas at Austin. Operating from Michael Dell's off-campus dormitory room at Dobie Center, the startup aimed to sell IBM PC-compatible computers built from stock components. Laptop once considered a luxury has now become an important gadget in the present era of technology rich world. Laptops are not only handy, but packed with features that are designed for portability and convenience. The sample size is 120 respondent. Majority (29.2%) of the respondent deciding factor is price. Likert scale value is 3.15 which is greater than 3. So the respondents are satisfied.

INTRODUCTION

The majority of modern laptops work on similar operating system. In laptops there are many brand are usually protected from use by others by securing a trade mark or service mark from an authorized agency usually government agency. Before applying for a trademark or service mark you need to establish that some one else has not already obtained one for your name. A brand name can created and stand for loyalty, trust, faith, premium or mass market appeal, depending on how the brand is marketed, advertised and promoted. A brand differentiates a product from similar other products and enables it to charge a higher premium, in return for a clear identity and greater faith in its function. A brand is also likely to survive longer than just an undifferentiated product.

Laptop once considered a luxury has now become an important gadget in the present era of technology rich world. Laptops are not only handy, but packed with features that are designed for portability and convenience. When compared to a desktop tower

computers, laptops are smaller, weigh less, have fewer components and consume less power. despite this, laptops a great choice for college students and busy professionals who travel often. In that we can see about the dell laptops.

Consumer is the principal a prior of business. The efficiency with which a free market system of enterprise operates, in the last analysis, depends upon the extend of consumer understanding possessed by the business community. A business community that is ignorant of consumer preferences cannot possibly fulfill its obligations in a meaningful and responsive manner. This is exactly the reason why consumer behaviour is given importance in modern marketing

STATEMENT OF THE PROBLEM

Due to the increasing globalization and homogenization of consumer's preferences in the world, global branding has become more widespread. That is why the cultural obstacles in marketing of the brand. Now a days, the consumer are more dynamic



their taste, needs and preferences can the changing as per current scenario. Hence the development of laptop industry mainly depends on the consumers buying behaviour and their preferences in purchasing the laptops. This study is undertaken to find the important attributes increasing brand awareness for DELL laptop in Coimbatore city. This study is fully focused on the consumer preference towards DELL Laptops in Coimbatore city.

SCOPE OF THE STUDY

In order to achieve steady growth in this highly competitive market, the companies should be aware of this competitors. This study will provide an overall view of brand awareness and consumer buying behaviour and market study of laptops. This study can be viewed from qualitative as well as quantitative nature, since it tries to know the opinions, views and suggestions of consumer and what can be done to improve the consumer buying behaviour and the preference on buying the laptops. This study is an attempt to study about consumer buying behaviour and preferences towards DELL Laptop in Coimbatore city.

OBJECTIVES OF STUDY

- To find out the consumer preferences on DELL Laptops.
- To study the factors which influencing the consumers to buy DELL Laptops
- To know the level of satisfaction towards DELL Laptops

RESEARCH METHODOLOGY

Research methodology is a systematic way to solve problems. It is a science of studying how research is to be carried out. Its aim is to give work plan of research. The following included in it.

RESEARCH DESIGN

Research design is a detailed blue print used to guide the research study towards its objectives. The research design for the study is descriptive analytical in nature that is conducted among the users of DELL Laptops especially in Coimbatore city

DATA COLLECTION

PRIMARY DATA

The primary data are those which are collected a fresh and the first time and the happens to be original in character. Primary data for this project was collected through questionnaire.

SECONDARY DATA

The secondary data are those which have already been collected by someone else and which have already been passed through the statistical process. Secondary data for this project were collected

SAMPLE DESIGN

Sample is the fraction of the population, sampling is technique or a method of selection of samples. The researcher in carrying out this research adopted the most appropriate sampling technique for research that is convenient sampling

SAMPLE SIZE

The sample size is 120 respondent

TOOLS FOR ANALYSIS

- Simple percentage analysis
- Likert scale analysis

REVIEW OF LITERATURE

T. Porkodi (2018)¹ has taken the problem that the consumers are satisfied or dissatisfied with the sales, services and supply of the laptops and other accessories for their continuous usage. In the study the researcher is to find out the satisfaction of the consumers towards the charges, the quality, the provisions and the level of consumer satisfaction towards the laptops for their official as well as the personal use. They are suggested to go for the right agency of the specific company for availing the services continuously.

Dr. S. Namasivayam (2016)² identified that the development of laptop industry mainly depends on customer satisfaction. The researcher can identify the factors and the preference of the respondents while purchasing laptops and know the level of satisfaction towards branded laptops. The researcher suggested that the companies should use multiple marketing channels to create brand awareness through TV media, Newspaper and Magazines.

Muhammad Faisal Sultan (2016)³ can study about the buying preferences of youth in the more important on the buying of laptops and to identify the impact of quality of laptops on the buying preferences of the youth and to determine the resultant of user friendliness



of laptops on the buying preferences of youth. This researcher concluded that the marketers must focus on price, quality brand image and celebrity endorsement in order to attract prospectus from youth.

M. Saravanan (2016)⁴ identify the various reasons on consumers buying behaviour in laptop like brand name, quality, price, capacity, style features, guarantee, after sales service, cash discount, instalment systems. The researcher suggested shall pay special attention to the above factors and to all problems revealed by the customer.

Sunil Kumar Dhal (2015)⁵can study the customer attitude and perception while purchasing a laptop. The researcher can identified that some of the factors that influence a consumer in selecting a laptop fur the purpose of study exploratory research design is used in the research . the researcher concluded that the customers are interest on the service and feature are the most important dimension to purchase a laptop and also the customer specifies eight dimensions are DVD drive, fashion and trend, design, features, warranty, gaming features.

Prince vohra (2015)⁶found that the advertisement plays vital in communicating to the customer about the product. Among the factors which are affecting their purchasing decision brand image is most important factor in shaping buying behaviour. It is observed in the study that advertisement is leading in the communication. So companies should spend more money on television advertiseme

DATA ANALYSIS AND INTERPRETATION

In this chapter the analysis and interpretation of the study on “ Consumer preferences and satisfaction towards dell laptops is presented based on the opinion of sample of 100 respondents in coimbatore city through structured questionnaire were analyzed through

**4.1 Simple presentage analysis****4.2 Likert scale Method****SIMPLE PERCENTAGE ANALYSIS****DECIDING FACTOR OF THE RESPONDENTS**

Factors	No of respondents	Percentage
Design	14	11.7%
Component	28	23.3%
Price	35	29.2%
Service offered by the seller	28	23.3%
Offer / Discount	15	12.5%
Total	120	100

*Sources data : Primary data***INTERPRETATION**

It shows the above mentioned table 4.1.8 shows that the deciding factor of the respondent Design is 11.7%, Components is 23.3%, Price is 29.2%, Service offered by the seller is 23.3%, Offer / Discount is 12.5%

INFERENCE

Majority (29.2%) of the respondent deciding factor is price

LIKERT SCALE ANALYSIS**PRICE SATIAFACTION LEVEL OF DELL USERS**

Satisfied Level	No of Respondents	Likert scale value	Total value
Highly Dissatisfied	6	1	6
Dissatisfied	34	2	68
Neutral	16	3	48
Satisfied	64	4	256
Highly satisfied	0	5	0
Total	120		378

*Sources data : primary data***INTERPRETATION**

$$\begin{aligned} \text{LIKERT} &= \Sigma (fx) / \text{Total number of respondents} \\ &= 378 / 120 \\ &= 3.15 \end{aligned}$$



INFERENCE

Likert scale value is 3.15 which is greater than 3. So the respondents are satisfied.

FINDINGS

SIMPLE PERCENTAGE ANALYSIS

- Majority (55%) of the respondents belong to the gender of male
- Majority (50.8%) of respondents belong to the age group of 18 - 27 years
- Majority (32.5%) of the respondent belong to the category of qualification with HSC
- Majority (68.3%) of the respondents are un married
- Majority (35%) of the respondents are students
- Majority (41.7%) of the respondents belong to the category of monthly income with 0 to 20000.
- Majority (39.2%) of the respondents need for the laptop in the profession is Normal
- Majority (29.2%) of the respondent deciding factor is price
- Majority (30.8%) of the respondents previously used laptops is HP
- Majority (25.8%) of the respondent expect Discount and Accessories from the DELL dealer
- Majority (27.5%) of the respondents preferred Bank Loan for finance
- Majority (28.3%) of the respondents known the DELL Laptops through Magazines/Newspapers
- Majority (25.8%) of the respondents are motivated by Convenience and connectivity.
- Majority(32.5%) of the respondent dislike the feature of Touch screen
- Likert scale value is 3.15 which is greater than 3. So the respondents are satisfied.

LIKERT SCALE ANALYSIS

- Likert scale value is 3.16 which is greater than 3. So the respondent are satisfied
- Likert scale value is 2.84 which is greater than 2. So the respondents are Neutral
- Likert scale value is 2.97 which is greater than 2 . So the respondents are Neutral
- Likert scale value is 2.78 which is greater than 2. So the respondents are Neutral.
- Likert scale Value is 3.11 which is greater than 3. So the respondents agree.

SUGGESTIONS

- This study suggested that the DELL Laptops company should concentrate more on students
- Most of the respondents facing Battery problems in their present Laptops. So, the DELL laptop company should concentrate on reducing the problems on Battery and improving the battery efficiency.
- All of the respondents need and expect the quick service from the DELL dealer. So the DELL Laptop dealer are to improve their quick service facility.
- Most of the respondents prefer the different colours and styles of the laptops. So the DELL company is concentrate on developing the style and comfort of the Laptops.

CONCLUSION

This study concluded that in this modern business economy it is very important to analysis the preference and satisfaction level of the consumer. The study result shows the majority of the consumer are satisfied with their DELL Laptops but also there is dissatisfaction because of some reason, such as battery back up and services rendered by the DELL dealers. The necessary steps taken. If the DELL Laptops company gives a proper services to the consumer there is a maximum queries are to be solved and the majority of the respondents would prefer the DELL Laptops and also suggest to their friends and relatives. This study concluded that the majority of the respondents are influenced by the convenience and connectivity of the DELL Laptops.

BIBLIOGRAPHY

1. T.Porkodi, A study on consumer preferences towards laptops in Tiruchirapalli District. *International journal of pure and Applied Mathematics*, ISSN: 1311-8080 119 (10), 2018.
2. Dr. S. Namasivayam, A study on brand awareness and consumers buying behaviour towards laptops with reference to Coimbatore city. *International journal of multidisciplinary Research and Development*, ISSN :2349-4182 3(2), 2016.
3. Muhammad Faisal Sultan, Factor influencing youth brand preference associated with purchase of laptop. *International Journal of Scientific and Research Publications.*, ISSN:2250-3153 6(8), 2016
4. M. Saravanan, A consumer buying behaviour while purchasing laptops in tirupattur town, *International Journal of Research Granthaalayah*, ISSN: 2350-0530 4(10), 2016
5. Sunil Kumar Dhal, A study of consumer buying behaviour and perception towards laptops in orrisa.



-
- International Journal of Innovative Science and Modern Engineering, ISSN: 2319-6386 3(6), 2015.*
6. Prince Vohra, Role of advertisement on customer buying behaviour of laptops in northern india, *International Conference on Technologies for sustainability - Engineering, Information Technology, Management and the Environment, ISBN:978-81-931039-7-5,2015.*
 7. D. Selvalakshmi, A study of consumer buying preference towards laptops with special reference to Trichy city. *International Journal of Advances Scientific Research & Development, ISSN: 2394-8906 2(2), 2015.*
 8. Dr. A C Brahmabhatt, A study of different factors influencing consumer's pre purchase buying behaviour towards laptop. *India Journal of Research, ISSN: 2250-1991 4(8), 2015.*
 9. Dr. Manivender Tandon, Consumer perception towards purchase of laptops. *International Journal of Marketing and Management Research, ISSN: 2229-6883 7(12), 2013.*
 10. Dr. P . Saravanan, A study on consumer usage and satisfaction regarding Lenovo in chinnamanur town. *International Journal of Engineering Research, ISSN: 2347-1670 4(9), 2013.*
 11. Dr. Srinivasa Rao, A study on customer preference of LG Laptops, *International Journal of Computational Engineering Research , ISSN 2250-3005 3(3), 2013.*
 12. Pinki Sharma, A study of brand choice of laptops by management and engineering students. *Researcher World, Journal of Arts Science Commerce, ISSN: 2229-4696 4(2), 2012.*

WEBSITES

- ✓ Shodhganga.inflibnet.ac.in
- ✓ www.indianjournals.com
- ✓ www.iosrjournals.org
- ✓ Info.dogpile.com



SECURE DATA GROUP SHARING AND CONDITIONAL DISSEMINATION WITH MULTI-OWNER IN CLOUD COMPUTING

Sai Navya G

MCA Scholar, School of CS & IT, Dept. of MCA, Jain (Deemed-to-be) University, Bangalore

Article DOI: <https://doi.org/10.36713/epra5768>

ABSTRACT

Secure inquiry methods cloud information permit an approved client to question information records of interest by submitting encoded question catchphrases to the cloud worker in a protection safeguarding way. In any case, practically speaking, the returned question results might be off base or deficient in the deceptive cloud climate. For instance, the cloud worker may intentionally exclude some certified outcomes to spare computational assets and correspondence overhead. Along these lines, a well-working secure inquiry framework ought to give a question results check instrument that permits the information client to confirm results. In this paper, we plan a protected, effectively coordinated, and fine-grained inquiry results confirmation system, by which, given a scrambled question results set, the inquiry client not exclusively can confirm the accuracy of every information document in the set yet additionally can additionally check the number of or which qualified information records in the set is deficient before unscrambling. The sheme is free coupling to concrete secure inquiry strategies and can be effectively integrated into any protected question plot. We accomplish the objective by building secure confirmation object for scrambled cloud information. Execution assessment shows that the proposed plans are useful and effective.

I.INTRODUCTION

Distributed computing is the utilization of registering assets that are conveyed as an assistance over an organization. The name comes from the regular utilization of a cloud formed image as a reflection for the perplexing framework it contains in framework graphs. Distributed computing depends far off administrations with a client information, programming and calculation.

The objective of distributed computing is to apply conventional supercomputing or superior registering power, ordinarily utilized by military and exploration offices, this distributed computing utilizes organizations of enormous gatherings of workers regularly running minimal effort buyer PC innovation with specific associations with spread information preparing errands across them. This mutual IT framework contains enormous pools of frameworks that are together.

As of late, with the developing prevalence of cloud computing, how to safely and productively search over encoded cloud information turns into an exploration center. A few methodologies have been proposed dependent on customary accessible encryption plans,

which mean to ensure information security and question protective measures with better inquiry productive for distributed computing. Wang et al. applied hash claim strategy to actualize the culmination check of question results by inserting the scrambled confirmation data into their proposed secure accessible record. Sun et al. utilized scrambled list tree structure to execute secure question results check usefulness. In this plan, when the question closes, the cloud worker returns inquiry results alongside a base scrambled file tree, at that point the information client look through this base list tree utilizing a similar pursuit calculation an obvious secure inquiry conspire over encoded cloud information dependent on quality based encryption method in the public-key setting.

In this paper, we stretch out and fortify our work to make it more pertinent in the cloud climate and safer to against unscrupulous cloud worker. The fundamental commitments of this paper are we officially propose the undeniable secure framework model and danger model and plan a fine grained inquiry results confirmations conspire for secure over encoded cloud information. We proposed a short signature strategy dependent on

certificateless public-key cryptography to ensure the genuineness of the check objects themselves. We plan a novel confirmation object demand strategy dependent on paillier encryption, where the cloud worker thinks nothing about what the information client is mentioning for and which check objects are gotten back to the client.

We give the proper security definition and confirmation and lead broad execution investigations to assess the precision and productivity of our proposed plans. Our plan can check the rightness of each encoded inquiry result or further precisely discover the number of or which qualified information documents are returned by the exploitative cloud worker. A short signature strategy is intended to ensure the genuineness of confirmation object itself

II . LITERATURE SURVEY

Creators: K.Ren:

Distributed computing speaks to the present most energizing figuring change in perspective in data innovation. Nonetheless, security and protection are seen as essential obstructions to its wide reception. Here, the creators diagram a few basic security challenges and rouse further examination of security answers for reliable public cloud climate.

Creators: S.Kamara and K.Lauter:

We consider the issue of building a safe distributed storage administration on top of a public cloud foundation where the specialist organization isn't totally trusted by the client. We portray, at a significant level, a few design that consolidate later and non-standard cryptographic natives to accomplish our goal.we study the advantages such an engineering would give to the two clients and specialist organizations and give a review of ongoing advances in cryptography roused explicitly by distributed storage.

Creators: D.Song, D.Wagner:

It is attractive to store information on information stockpiling workers, for example, mail workers and fake workers in encoded structure to decrease security and protection hazards .yet this normally suggests that one needs to forfeit usefulness for security realized how to let the information stockpiling worker play out the inquiry and answer the words, it was not recently realized how to let the information stockpiling worker play out the hunt and answer the question, without loss of information secrecy. We portray our cryptographic plans for the issue of looking on scrambled information and give confirmations of security to the subsequent crypto frameworks. Our methods have various critical preferences. They are provably secure: they give provably safely to encryption, as in the untrusted worker can't master anything about the plaintext when just given the ciphertext; they give inquiry disengagement to look, implying that the untrusted worker can't pick up much else about the plaintext than the query item; they give controlled looking, so that the untrusted worker can't look for a subjective word without the client's

authorization;they additionally uphold covered up queries,so that the client may approach the untrusted worker to look for a mystery word without uncovering the word to the worker. The calculations introduced are straightforward, quick

III. SYSTEM ARCHITECTURE

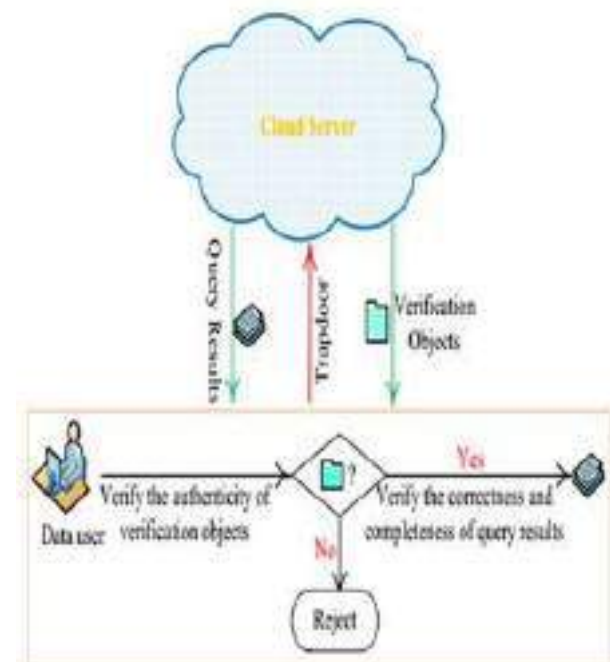

IV. DATA FLOW DIAGRAM

The DFD is additionally called bubble chart. It is a straightforward graphical formalism that can be utilized to speak to a framework as far as info information to the framework, different handling did on this information, and the yield information is created by this framework. The information stream outline is one of the main displaying instruments. It is utilized to demonstrate the framework segments. These parts are the framework cycle, the information utilized by the cycle, an outside element that associates with the framework and the data streams in the framework. DFD shows how the data travels through the framework and how it is altered by a progression of changes. It is a graphical procedure that portrays data stream and the changes that are applied as information moves from contribution to yield. DFD is otherwise called bubble diagram. A DED be utilized to speak to a framework at any degree of reflection. DFD might be parceled into level that speak to expanding data stream and utilitarian detail.

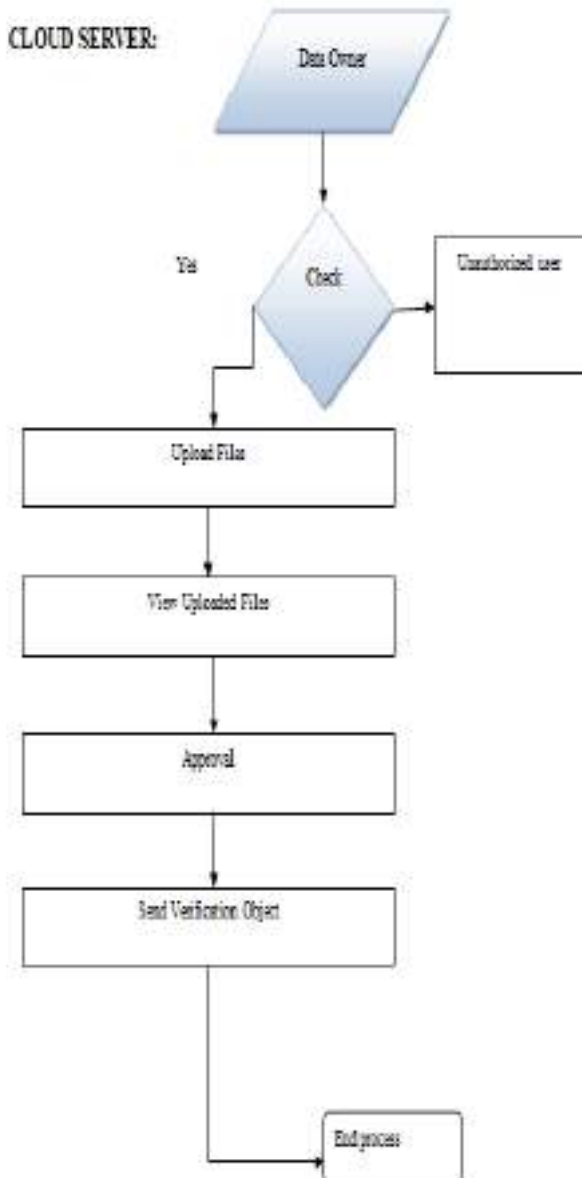

V.GOALS

The essential objectives in the UML are:

1. Give clients a prepared to utilize, expressive visual demonstrating language with the goal that they can create and trade significant models.
2. Give extendibility and specialixation components to expand the center ideas.
3. Be autonomous of specific programming language and advancement measure.
4. Give a proper premise to understanding the displaying language.
5. Energize the development of OO devices market.
6. Backing higher advancement ideas, for example, joint efforts, systems, examples and segments.
7. Incorporate prescribed procedures.

VI. CONCLUSION

In this paper, we propose a safe, effortlessly incorporated, and fine grained inquiry results confirmation plot for secure hunt over encoded cloud information not quite the same as past works, our plan can check the rightness of each scrambled question result or further a precisely discover the number of or which qualified information records are returned by the unscrupulous cloud worker. Ashort signature strategy is intended to ensure the realness of check object itself. Also, we plan a protected check object demand procedure, by which the cloud worker thinks nothing about confirmation object is mentioned by the information client and really returned by the cloud worker. Execution and precision tests exhibit the legitimacy and proficiency of our proposed plot.

VII. REFERENCES

1. P. Mell and T. Grance, "The nist definition of cloudcomputing,"<http://dx.doi.org/10.602/NIST.SP.800-145>.
2. S.Kamara and K.Lauter, "Cryptographic cloud storage," in *Springer RLCPS*, January 2010.
3. D.Song, D. Wanner, and A. Perrig, "Practical techniques for searches on encrypted data," in *IEEE Symposium on Security and Privacy*, vol.8, 2000,pp.44-55.
4. E.-J.Goh, "Secure indexes," *IACRe Print Cryptography Archive*, <http://eprint.iacr.org/2003/213>, Tech.Rep., 2003.
5. D.Boneh, G.D.Crescenzo, R.Oatrovsky, and G.Persiano, "Public-Key encryption with keyword search," in *EUROCRYPT*,2004,pp.506-522.
6. R.Curtmola, J.Garay, S.Kamara, and R.Ostrovsky, "Searchable symmetric encryption :im proved definition and efficient constructions," in *ACM CCS*, vol. 19,2006,pp. 79-88.
7. M.Bellare, A.Boldyreva, and A.O'Neill, "Deterministic and efficiently searchable encryption," in *Springer CRYPTO*, 2007.
8. S.Kamara and C.Papamanthou, "Parallel and dynamic searchable symmetric encryption,in *Financial Cryptography and Data Security* ,Springer Berlin Heidelberg,2013 ,pp.258-274.
9. M.Naveed, M.Prabhakaran , and C.a. Gunter, "Dynamic searchable encryption via blind storage," in *IEEE S&P*, May 2014,pp.639-654.
10. C.Wang, N.Cao, J.Li, K.Ren, and W.Lou, "Secure ranked keyword search over encrypted cloud data," in *IEEE ICDCS*,2010,pp. 253-262.
11. N.Cao, C.Wang, sM. Li, K. Ren, and W. Lou, "Privacy-preserving multi-keyword ranked search over encrypted cloud data," in *IEEE INFOCOM*,2011, pp.829-837.
12. M. Bellare and P. Rogaway, *Introduction to Modern Cryptography. Lecture Notes*, 2001.



VOLATILE ORGANIC COMPOUNDS

Deepika Bhardwaj¹

¹PhD Research scholar, South Asian University, New Delhi-21

Shikha Bharati²

²PhD Research scholar, School of Life sciences, Jawaharlal Nehru University, New Delhi-67

Ranjan Kumar³

³PhD Research scholar, School of Life sciences, Jawaharlal Nehru University, New Delhi-67

Manoj Kumar⁴

⁴PhD Research scholar, School of Life sciences, Jawaharlal Nehru University, New Delhi-67

Article DOI: <https://doi.org/10.36713/epra5763>

1. ABSTRACT

Diverse amount of volatile organic compounds is synthesized by plants, proven to be of utmost importance to the plants in various stages of their perpetuation cycle. Their functions are attraction of insects for pollination, dispersal of seeds, helping plants to withstand competition from neighboring plants, contributing towards maintaining plant biodiversity, helping in growth of agriculturally important plants and aiding plants in combating both abiotic stress and biotic stress. Calcium ions and ROS (reactive oxygen species) plays a crucial role as signaling molecules in plants in pathways dealing with induction of synthesis of VOCs in response to various biotic and abiotic stresses and the mechanisms elucidating the survival of plants in such conditions. Apart from this, the concern arising from the expected effects of global climatic changes on rate of synthesis and emission of VOCs in plants has also been expressed. The later part of the paper highlights the beginning of a novel field of metabolic engineering which deals with engineering of biochemical pathways of biosynthesis of VOCs in a manner so as to maximize the yield of beneficial VOCs and at the same time minimizing the yield of harmful VOCs to obtain desired results. The achievements that have been attained, the unintended effects that creep in and the challenges that need to be overcome to make advancements in the field of metabolic engineering have also been included.

2. INTRODUCTION

VOC or volatile organic compounds are lipophilic liquids or chemical compounds that exhibit low molecular weight and high vapour pressure at ordinary room temperature which allows them to evaporate or sublime from solid or liquid form of the compound into the surrounding environment (Pichersky et al., 2006).

VOCs are omnipresent and countless in number. They include both anthropogenic VOCs which are manmade and natural VOCs.

Anthropogenic VOCs have to be strictly monitored by law and kept under effective surveillance since immense hike in their levels can pose an imminent threat to the environment. Harmful VOCs are not profoundly pernicious but they have long lasting effects on health such as short term exposure (acute) and long term exposure (chronic) to high level VOCs. Short term exposure leads to increased risk of infection and irritation in eye, nose, throat, headaches, difficulty for asthma patients. Whereas long term exposure increases the risk of some deadly



diseases i.e. cancer, also damages kidney, liver and central nervous system.

Plants also congregate multitudinous no. of products that are natural and believed to help plants in communication with surrounding environment and perform a lot of functions including attracting beneficial insects for pollination (Knudsen et al., 2006) thus being of immense use in the perpetuation cycle of the plants, defending plants from the attack of herbivorous animals either by killing them and deterring them directly or in an indirect manner by attracting carnivorous animals which feed on herbivores (Shiojiri et al., 2006; Croft et al., 1993), signalling within the same plant to protect the undamaged plant parts following a herbivore attack and among different plants when one of the plants is damaged by the herbivore attack by venting out a blend of VOCs which warn the neighbouring plants of the emanating danger which leads to activation of defence mechanisms in neighbouring plants, promote plant competition (Franklin, K.A. 2008), protect the plant from prevailing abiotic stresses and contribute a great deal to promote biodiversity within various angiosperms by preventing inbreeding (Waelti et al., 2008). Above mentioned compounds are called secondary metabolites so, that it can get differentiated from primary metabolites which plays a role in the growth and development along with reproduction of an organism whereas secondary metabolites do not play direct role in the above processes but rather perform ecological functions and contribute to the sustenance of an organism in its ecological niche, thus contributing to reproductive fitness of an organism (Theis and Lerdan, 2003). More than 1700 VOCs have been discovered in angiospermic plants till date (Dicke and Loreto, 2010). Momentous significance of Volatile compounds was highlighted when the fact was revealed that almost 36% of the carbon assimilated by plants is released during photosynthesis as VOCs (Kesselmeier et al., 2002). Healthy unwounded plants dissolve accumulated VOCs, which depends on the physical and chemical properties along with the concentration of these VOCs (Niinemets et al., 2004). Opposed to it there are certain plants which do not synthesize and emit VOCs into the environment until and unless triggered by an external stimulus or stress. Such VOCs are induced VOCs which are dissipated from both stressed sites as well as systematically from undamaged plant leaves (Pare and Tumlinson, 1997). Since induced VOCs are induced only under stress conditions unlike constitutive VOCs, they do not cause a great deal of burden on the carbon content of the plant and are very economical (Dicke, 2000). A large number of induced VOCs are known to exist in the environment including alkenes, alkanes, carboxylic acids, nitrogen containing

compounds and alcohols, but the dominating ones are isoprene, terpenes, and C6 green leaf volatiles (GLVs) (Holopainen and Gershenzon, 2010).

3. BIOSYNTHESIS OF VOCs

VOCs are produced from a number of biochemical pathways in plants. The common types of VOCs present in plants and the pathways contributing to their biosynthesis are as follows:

a. Isoprenoids: C5 unit which is chemically 3-methyl 1, 2-butadiene, is termed as isoprene. All isoprenoids are produced from dimethyl allyl diphosphate (DMAPP) and its isomer Isopentenyl diphosphate (IPP) which is synthesized by deoxyxylulose-5-phosphate (DXP or MEP) pathway in chloroplast or by mevalonate (MVA) pathway in cytoplasm. (Kesselmeier and Staudt, 1999). It is believed that C10 precursors of monoterpenes are synthesized within plastids by MEP pathway whereas precursors of sesquiterpenes (C15) are synthesized in cytoplasmic MVA pathway.

Certain VOCs such as β -ionene are not generated directly from IPP, rather cleavage of tetraterpenes like carotene is the major backing force behind their production and this cleavage is brought about by carotenoid cleavage dioxygenases (CCDs). Homoterpenes such as 4, 8-dimethylnona-1, 3, 7-triene (DMNT) and 4, 8, 12-trimethyltrideca-1, 3, 7, 11-tetraene (TMTT) are the terpenoids that are formed in response to herbivore feeding (Holopainen, 2004; Arimura et al., 2005, 2009). The biosynthesis of TMTT and DMNT is brought into action by oxidative degradation by CYP450 enzymes of the diterpene geranyl linalool and the sesquiterpene (E)-nerolidol as precursors respectively (Holopainen, 2004; Arimura et al., 2005, 2009). Quite a large number of terpenoids are synthesized by terpene synthases (TPS) using geranyl diphosphate (GPP) and farnesyl diphosphate (FPP) as precursors (Owen et al., 1997, 2001; Lin et al., 2007; Arimura et al., 2008 a, b, 2009; Wu and Baldwin, 2009).

b. Oxylipins: Oxylipins are derived from polyunsaturated fatty acids which are discharged from chloroplast membranes by lipase activity. They form the precursors for biosynthesis of a large number of oxygenated compounds including jasmonates as well as green leafy volatiles (GLVs). GLVs are synthesized from C18 polyunsaturated fatty acids like linoleic acid and linolenic acids via LOX (Lipoxygenase) pathway (Dudareva, 2005). C18 acids are initially cleaved to C12 and C6 compounds by hydroperoxide lyases (Engelberth et al., 2004). The first C6 compound so formed is 3-Z-hexanal which is later converted to other GLVs such as 2-hexanal, 3 hexanol, and 3-hexenyl acetate (Shiojiri et al., 2006).



c. Volatile Aromatic Compounds: Another class of VOCs is formed by class of compounds that consists of an aromatic ring involving shikimate pathway. VOCs that contain nitrogen or sulfur are synthesized by cleavage reactions of modified amino acids or their precursors as is seen in case of indole which is formed in maize by cleavage of Indole-3-glycerol phosphate which is an intermediate in tryptophan biosynthesis (Koeduka et al., 2006). Indole is released in plants in response to herbivore attack.

Certain aromatic VOCs are derived from phenylalanine. Eugenol is one such alcohol which is derived by decarboxylation and oxidative removal of amino group of phenylalanine (Pichersky et al., 2006). Salicylic acid can be formed via two pathways – either by delivering benzoate from cinnamate or using isochorismate. Methyl salicylate is synthesized from salicylic acid in a reaction involving transfer of a methyl group from S-adenosine-methionine (SAM) to the carbonyl group of salicylic acid in the presence of enzyme methyltransferase (Vassao et al., 2006).

4. REGULATION OF VOC EMISSION

There are several factors controlling the rate of emission of VOCs in plants. Some of them are:

a) Control at transcriptional and translational level- Genes involved in biosynthesis of VOCs are upregulated subsequent to a herbivore attack on the plant via jasmonic acid, salicylic acid and ethylene signalling pathways (Hermsmeier et al., 2001; Kant et al., 2004 ; Ralph et al., 2006).

Emission of VOCs also seems to analogize with the activity of enzymes controlling their synthesis both under normal and stress conditions (Kuzma and Fall, 1993; Loreto et al., 2001a; Fischbach et al., 2002). Thus, we gather that emission of VOCs is regulated not just at transcriptional level but also at post transcriptional, translational and post translational level.

b) Substrate availability- It is a major factor controlling the biosynthesis and emission rates of VOCs. Though certain enzymes that are involved in biosynthesis of VOCs are very promiscuous and exhibit broad substrate specificity and thus synthesize different types of VOCs accordingly (Negre et al., 2003; Boatright et al., 2004; Pott et al., 2004). The significance of substrate availability for the biosynthesis of VOCs is clearly seen in transgenic tobacco in which genetic modification leading to switching of cytosolic or plastidic isoprenoid precursors led to increased biosynthesis of VOCs (Wu et al., 2006).

c) Circadian regulation - Emission of VOCs from flowers, leaves and other floral parts are seen to show diurnal or nocturnal patterns (Dudareva et al., 2005; Wilkinson et al., 2006; Loivamaki et al., 2007). The

underlying cause behind this circadian regulation of emission of VOCs might be somehow related to substrate availability and transcriptional control (Yakir et al., 2007).

d) Physiological factors - Leaf temperature, stomatal conductance, leaf morphology, soil moisture availability, carbon dioxide concentration and ozone concentration also affects the rate of emission of VOCs.

e) Light availability - Certain plants like *Pinus*, *Eucalyptus* and those in Rutaceae family are equipped with storage compartments for VOCs like resin ducts, cavities, oil glands and glandular trichomes while others like oaks completely lack them. The emission rate in the latter is coupled to the incident light intensity (Staudt and Bertin, 1998) while in the former ones, the emission rate is controlled by leaf temperature which has a marked effect on volatilization of VOCs (Tingey et al., 1980). Certain VOCs like isoprene, being highly volatile are not stored at all.

5. FUNCTIONS OF VOCs IN PLANTS

VOCs form the lifeline of plants. Plants inhabit a hostile environment where they are constantly exposed to all sorts of biotic and abiotic stresses and competition from neighbouring plants for sharing the limited pool of nutrients, water and other resources in order to sustain their existence. VOCs play a remarkable role in enabling plants tackle all these stressful situations efficiently.

5.1 ROLE OF VOCs IN PLANT REPRODUCTION

Since plants are sessile and cannot move from one place to another for pollination and can neither avoid it because it is an indispensable part of their perpetuation cycle, so plants are in constant search for external agents that can aid them in fulfilling this purpose. Insects play a pivotal role in the life cycle of plants being major pollination agents and this is where the role of plant secreted VOCs come into play. Out of the five basic senses that every organism possesses, olfaction and visualization play an important role in pollination. As is said in one of the theories of epigenetics that external features or ornaments are key players in promoting the sexual selection, the same concept applies here as well, flowers are “biological markets” for pollinating insects from which only the ones which have compatible colors and scent which is appealing to the insects are chosen for pollination (Chitka and Raine, 2006). The presence of aromatic and chromatic cues enables the insects to differentiate between different flowers and thus insects inculcate the habit of repeatedly visiting the flower which is of their interest on the basis of retrieval of memories (Kunze and Gumbert, 2001).



Different floral parts like sepals, petals, pollen and nectar emit diverse blends of VOCs (Dudareva et al., 2000; van Schie et al., 2006). Floral VOCs are species specific. For example, plant species pollinated by moths emit high amount of benzenoids and to a lesser extent terpenoids and nitrogen containing compounds (Dobson, 2006) while bat pollinated flowers predominantly release sulfur containing VOCs (von Helverson et al., 2000). Pollinators are very shrewd and capable of distinguishing between complex multicomponent VOC profiles with unique ratios and intensities of compounds (Wright et al., 2005) and preferentially reach for the plant of specific volatile profile thus ensuring flower constancy and increasing pollen transfer to specific plants thereby avoiding stigma congestion with unspecific pollen. This phenomenon has been seen in honeybees which repeatedly visit the same flower even when other flowers in the surrounding environment offer better rewards. This is beneficial for the flower since pollen deposition on conspecific stigma is ensured but the honeybee seems to be disadvantaged in the whole process since it loses on the surrounding flowers that are offering better rewards (Gruter and Ratnieks, 2011). VOCs emitted from pollen are chemically different from the VOCs secreted by other plant parts majorly containing benzyl tiglate, isopinocampone, dimethyl glutarate, dimethyl adipate and many other VOCs (Dobson et al., 1996; Flamini et al., 2002). Moreover, the diversity of compounds is often lower in pollen VOCs (Knudsen and Tollsten, 1991; Dobson et al., 1996). Odor emitted from pollen is advantageous to the plant since it attracts pollen plundering insects which leads to increased rates of pollen dissemination (Dobson and Bergstrom, 2000). But along with it come two disadvantages – need of use of specialized mechanisms to evade the effect of non-pollinating insects that uselessly capitalize on the plant without doing any good to it and a substantial amount of energy needs to be expended in improving the pollen odour to attract large number of insects for pollination (Hargreaves et al., 2009).

VOCs emitted from pollinated flowers play the unique and noble role of directing pollinator insects to yet unpollinated flowers (Schiestel and Ayasse, 2001).

A quite strange phenomenon of down regulation of the emission of VOCs has been seen in *Silene latifolia* flower wherein apart from acting as pollination signals, VOCs also act as flower antagonists by attracting the pollinator *Hadena bicurris* whose larvae feeds on the developing seeds of the plant ultimately killing it. To evade such disastrous cessation to the plant, the amount of VOCs has to be downregulated subsequent to pollination (Wolfe, 2002; Dotterl et al., 2006).

Nectar also acts as one of the components that a plant employs for attracting the insects. Apart from the primary metabolites like sugar and amino acids, nectar also contains certain secondary metabolites such as alkaloids, phenolics and nonprotein amino acids (Baker, 1977) which have deterrent effect on so called nectar thieves and sometimes also have undesired negative effects on pollinators' visits (Stephenson, 1981; Kessler and Baldwin, 2007).

Apart from being of immense importance in attracting insects for pollination, VOCs also play a crucial role in seed dispersal. VOCs secreted from fruits and seeds/spores attract various animals that aid in seed dispersal in the ecosystem. For example, blends of VOCs emitted from seeds of epiphyte *Peperomia macrostachyam* attract ant-garden ants in the Amazon rainforests and exploit their seed collecting behaviour (Youngsteadt et al., 2008). Similarly, VOCs secreted from mature fruits attract bats which help in fruit dispersal (Hodgkison et al., 2007).

5.2 ROLE OF VOCs IN NEIGHBOR DETECTION AND PROMOTING PLANT COMPETITION

Herbert Spencer rightly quoted the phrase “survival of the fittest”. If you do not compete with others, you will fall off the wheel of life and be outcompeted. This applies to plant systems as well. There is an ongoing conflict between a plant with its neighbouring plants for water, nutrients, light and other resources. Depending on which resource plants are competing for, they will accordingly portion out more amount of carbon to roots (if competition is for water and nutrients) or shoot (if competition is for light). While competing for light, carbon is used for shade avoidance responses which involve movement of leaves towards light and enhanced internode elongation so that all the leaves can occupy positions in the well-lit area for effective photosynthesis to occur (Franklin, K.A., 2008).

In areas of dense vegetation where plants grow in clustered fashion, the urge for competition is even heightened because limited space harbours a large number of plants and they have to fall back on limited nutrients, water and light for survival. Role of VOCs becomes even more important in such areas. A large number of signals can be used by plants for detection of neighbouring plants growing in their vicinity. Reduced amount of R/FR and of blue light - Plants use red and blue light for photosynthesis while far red (FR) light is reflected back. Reduced levels of R/FR and reduced blue light fluence rates are detected by phytochrome, cryptochrome and phototropin family of photoreceptors respectively, this is followed by intense competition for light and instigation of shade avoidance response (Franklin,



K.A., 2008). Ethylene – Being a volatile hormone, amount of ethylene serves as a neighbour detection signal in a canopy (Pierik, R. et al., 2004). Lowered wind exposure – Diminished wind flow rates also act as neighbour detection signal in dense vegetation (Anten, N.P.R. et al., 2005). Underground communication – Reduced availability of nutrients, groundwater and root exudates also act as neighbour detection signals (de Kroon, H. 2007). Neighbour detection is followed by cut throat competition within the neighbouring plants in order to sustain their own being and outcompete the neighbour. Resource limitation has a marked effect on the emission rates of VOCs. VOCs secreted from one plant can have the following effect on its neighbouring plants:

a) The growth and development of the neighbouring plants will be retarded. This phenomenon in which a plant secretes certain allelochemicals in its surrounding environment which arrest the growth and development of neighbouring plants is called allelopathy.

b) Certain neighbouring plants also exhibit the property of exploiting the HIPVs (Herbivore induced plant volatiles) emission from the allelopathic plant to their advantage by using VOCs as a signal for the presence of nearby competitors and accordingly inculcating responses that enhance the competitive powers of the snooping neighbour (Wouter Kegge and Ronald Pierik, 2009).

VOCs acting as allelochemicals can be secreted from any part of the plant, be it underground or above ground. Allelochemicals are tissue specific and this fact was highlighted when it was seen that root emitted monoterpenoid VOCs such as camphor, camphene, 1, 8 cineole and β -pinene from *Salvia leucophylla* root inhibited root germination and growth in *Brassica campestris* but at the same time the effect was localized only to the root region and no traces of any such effect were visible in the shoot apical region (Nishida, N. et al., 2005). Interestingly, it is seen that root germination of competitors is affected not just by the root emitted VOCs but by shoot emitted VOCs as well. This fact was highlighted when it was noticed that VOCs emitted from *Antirrhinum majus* flowers inhibit root growth in neighbouring *Arabidopsis* plants under laboratory conditions which was later investigated to have occurred due to methyl benzoate present in the blend of VOCs secreted from the plant which has adverse effect on the expression of genes regulating growth hormones such as auxin and cytokinin (Horiuchi, J. et al., 2007).

A strange observation noticed during study of *Artemisia tridentata* showed that when its leaves were cut, it inhibited the germination of neighbouring plants. But if somehow an arrangement was made to prevent the air contact and allow just the soil

transmittance, no such inhibition was seen. This observation led to the inference that on clipping the leaves, *Artemisia tridentata* emitted VOCs that inhibited the growth of neighbouring plants as a means of avoiding competition (Karban, R., 2007). But if you look the whole scenario from another perspective, one more mind boggling idea pops up into your mind that rather than being an allelopathic effect at all, inhibition of root germination could just have been an adaptive measure up-taken by neighbouring plants upon detection of herbivore mediated clipping of the leaves of *Artemisia tridentata* to evade the ensuing threat of being damaged by herbivore in the early seedling stage. This clearly proves that apart from acting as allelochemicals in some of the plant species, VOCs also act as neighbour detection signals in certain species. A very common plant illustrating this behaviour is *Cuscuta pentagona*, a parasite which spots its host by monitoring the blend of different VOCs secreted by its host plant. This host detection system is so advanced and sensitive that *Cuscuta pentagona* can efficiently discriminate between different neighbouring species based on their volatile profiles (Runyon, J.B. et al., 2006).

5.3 ROLE OF VOCs IN CONTRIBUTING TOWARDS PLANT BIODIVERSITY

The exact mechanism which led to speciation in angiosperms is not known till date but VOCs are thought to play an important role in maintaining prezygotic isolation mechanisms within plants and contributing to maintenance of reproductive isolation. This is done by controlling pollinator behaviour which in turn is determined by pollinator's attraction to specific signals in a flower like flower colour, size and the blend of VOCs secreted by a particular flower. A pollinator very shrewdly manages to differentiate between closely related plant species by monitoring their volatile profiles. Volatile profile of each and every plant, even the ones belonging to closely related species differs from each other owing to different intensity, ratios of constituents and the presence of unique compounds in the blend of VOCs secreted from them. This phenomenon is clearly highlighted in case of sexually deceptive orchids belonging to the genera *Oophrys* and *Chiloglottis* in which flowers emit VOCs whose odour resembles the scent of female pollinator's sex pheromone thus masquerading laying the male pollinator into its trap (Schiestl, 2005). It has been seen that each orchid belonging to the above mentioned genera vents out a different species specific volatile profile providing a unique cue for a single pollinator species (Ayasse et al., 2011). Volatile profiles emitted by two very closely related species and differing just by a single VOC are good enough for a pollinator to distinguish



between the two species and this behaviour has been seen in *Silene dioica* and *Silene latifolia* whose volatile profiles differing just by phenylacetaldehyde where volatile blends have the same constitution but in different relative amounts are good enough to cause reproductive isolation between the two species (Waelti et al., 2008).

When this phenomenon of reproductive isolation in sexually deceptive orchids belonging to genus *Oophrys* was traced back to find the cause underlying it, it was concluded that this occurred due to species specific alkene emission profiles that are defined by differences in enzyme activity and gene expression of a few stearoyl-acyl carrier protein desaturases (Schluter et al., 2011; Xu et al., 2012).

5.4 IMPACT OF VOCs ON AGRICULTURE

Pollinators play a very critical and unparalleled role in the life cycle of plants, especially in those plants which exhibit the trait of self-incompatibility. It has been observed that plants like *Citrus glandis* in which flowers are self-incompatible release more amount of VOCs because they are completely at the mercy of pollinators for effectuating their perpetuation cycle as compared to orange, grapefruit and lemon which have flowers with both male and female organs (Jabalpurwala et al., 2009).

A number of studies have been conducted which highlight the extreme dependence of pollinator attraction on the volatile profiles secreted by a plant. A very good example linking this phenomenon with the development of GM crops is seen in Bt gene (cry3Bb) expressing eggplant. The main aim of inserting Bt gene in egg plant was to confer an insect pest resistance to it. Apart from lending the intended property of insect pest resistance, Bt gene also fortuitously bestowed the property of causing emission of five major VOCs (methyl salicylate, Z-jasmone, α -pinene, α -methyl styrene and d-2-carene) all of which kindled positive responses in bee antenna and even drew a greater population of bumblebees as compared to the wild type varieties despite possessing significantly smaller flowers and plant size.

To date there have been only two examples that corroborate the link between floral VOC emission and crop pollination failure. One of them is seen in Alfalfa which is completely at the mercy of honeybees for bringing about pollination and frequency of honeybees visiting its flower is very low because of the special composition of its volatile profile whose major constituent is ocimene which faces a negligent behaviour from honeybees and at the same time, the component which acts as a strong chemoattractant for honeybees that is linalool, is present in very minute quantities in its volatile

profile. The delinquency exhibited by honeybees is the major determinant of low seed production in alfalfa (Henning and Teuber, 1992). Apart from this, alfalfa also emits certain deterrents that manacle honeybees from visiting its flower.

5.5 ROLE OF VOCs IN PLANT DEFENSE

A plant continuously thrives in a perilous environment under the threat of being attacked by herbivores and pathogens. It is the blends of VOCs secreted from flowers, roots and leaves of plants that come handy in such situations as they exhibit antimicrobial properties and work like magic wands in protecting the plants from the action of invading pathogens (Croft et al., 1993; Shiojiri et al., 2006).

5.5.1 BIOSYNTHESIS AND REGULATION OF TERPENOIDS IN RESPONSE TO HERBIVORY

This figure illustrates the mechanism underlying biosynthesis of terpenoids in response to herbivore attack in two different types of herbivores—chewing arthropods and sucking arthropods.

The very first event that occurs in a herbivore damaged plant is increased influx of Ca^{+2} into the cytoplasm from extracellular environment in response to the elicitors injected into the plant from insect oral secretions.

This increased influx of calcium ions leads to jasmonic acid mediated biosynthesis of terpenoids in chewing arthropods and both jasmonic acid and salicylic acid mediated biosynthesis of terpenoids in sucking arthropods. Ethylene also plays a significant role in terpenoid biosynthesis in response to attack by chewing arthropods in two ways:

- By effecting increased calcium ion influx into the cytoplasm.
- By regulating the downstream jasmonic acid mediated biosynthesis of terpenoids (Arimura et al., 2008a).

The terpenoids so produced attract predators that feed on herbivores thus killing them.

5.5.2 ROLE OF Ca^{+2} IN SIGNALING PATHWAY LEADING TO PRODUCTION OF TERPENOIDS

Calcium ions act as a second messenger in the biosynthesis of terpenoids synthesized in response to herbivory and also have a casting effect on the composition of terpenoids synthesized.

Maintenance of intracellular calcium levels is very important for the survival of the cell. The cytosolic concentration of calcium ions is kept low (0.0001 mM) as compared to the extracellular medium and subcellular compartments like mitochondria, endoplasmic reticulum and the vacuole



(0.1 mM). This concentration is maintained by Ca^{+2} homeostasis system which consists of large calcium ion stores which can release calcium ions, calcium ion channels/pumps which control both Ca^{+2} influx and efflux in cells and subcellular compartments and Ca^{+2} binding proteins like calmodulin that bind to Ca^{+2} and congregate them (Pandey et al., 2000). Ca^{+2} ATPases located in subcellular compartments play a momentous role in maintaining this gradient by relentlessly pumping Ca^{+2} out of the cytosol (Allen et al., 1995).

5.5.3 ROLE OF ROS IN SIGNALING PATHWAY LEADING TO FORMATION OF VOCs

Apart from Ca^{+2} , reactive oxygen species (ROS) also act as signaling and defense molecule in response to herbivory. Just like skin, which forms the first line of defense against invading pathogens in humans, production of ROS is the first barrier that a plant uses to combat an invading pathogen or insect. Under normal conditions, the level of ROS is kept low by the activity of antioxidant systems which include secondary metabolites and scavenging enzymes (Foyer and Noctor, 2005a, b; Pandhair and Sekhon, 2006). However, a biotic or abiotic stress leads to increased ROS production or decreased antioxidant potential (Apel and Hirt, 2004; Asada, 2006; Davies et al., 2006; Foyer and Noctor, 2003; Hancock et al., 2002).

Quite a large number of enzymes like NADPH oxidase, superoxide dismutase, peroxidase, polyamine oxidase and diamine oxidase are present in apoplast which function in production of ROS which directly kills the insect and can aid in strengthening the cell wall due to polymerization. This mechanism of herbivore killing is termed as apoplastic oxidative burst (Bhattacharjee, 2005; Bolwell et al., 2002).

Oral secretions from salivary glands of herbivores produces H_2O_2 which diffuses inside the plant cell through specific hydroperoxidoporphyrins which leads to an increase in cytosolic H_2O_2 concentration which is neutralized by scavenging enzymes like catalase, ascorbate oxidase and glutathione peroxidase which apart from it normally neutralize the ROS and H_2O_2 formed in subcellular compartments like peroxisome in which nitric oxide and H_2O_2 are formed on the cytosolic side of the membrane (Corpas et al., 2001; del Rio et al., 2006), mitochondria in which ROS is mainly formed in ETC (Navrot et al., 2007) and chloroplast in which ROS is mainly formed in reaction centres of PS1 and PSII of thylakoids (Asada, 2006).

Apart from operating at the above ground level, defense system also operates at below ground level as seen in maize roots, which on being attacked

by the insects secretes sesquiterpene, β -caryophyllene, which in turn attracts another class of predators, nematodes, which feed on the insect larvae thus killing it (Rasmann et al., 2005).

5.5.4 BIOSYNTHESIS AND REGULATION OF GREEN LEAF VOLATILES IN RESPONSE TO HERBIVORY

Another class of VOCs that are synthesized in response to herbivory include green leafy volatiles (GLVs) which are formed in plants in immediate response to a biotic or abiotic stress within a minute utilizing the LOX pathway (Matsui et al., 2006). Unlike terpenoids which are involved only in indirect defense, GLVs are involved in both direct and indirect defense responses following herbivory (Shiojiri et al. 2006a, Chehab et al. 2008). The very first product formed in the signalling cascade in response to the elicitors secreted by insects into the plants is (Z)-3-hexanal which can either kill the invading herbivore thus acting as a means of direct defense and can also diffuse from the wounded area to the nearby tissues and on oxidation with the help of alcohol dehydrogenases forms (Z)-3-hexen-1-ol which further gets oxidized using acyltransferase to form Z-3-hexen-1-yl-acetate. The GLVs so formed can be used for indirect defense involving attraction of predators for feeding on the herbivore and used as cues by the snooping neighbouring plant to inculcate defense responses within it in response to the ensuing herbivore attack.

It is seen that the first appearance of GLVs in response to herbivore damage takes only few seconds while herbivore induced production of terpenoids takes many hours since the latter involves activation of the genes controlling terpenoid synthases (TPS) which takes quite a long time. Moreover, the production of GLVs is brought about by pre-existing enzymes rather than induced enzymes which further hastens the process involving their formation. Apart from herbivore damage, GLVs have also been seen to be formed in plants even in cases of oxidative damage to plants and in exposure to high temperature and high light intensity (Beauchamp et al., 2005, Loretto et al., 2006).

Besides protecting the plant which has been attacked by a herbivore, VOCs like methyl jasmonate (Farmer & Ryan, 1990), methyl salicylate (Shulaev et al., 1997), some green leaf volatiles (Engelberth et al., 2004; Farag et al., 2005) and some terpenes (Arimura et al., 2002) also act as defence signals between neighbouring plants belonging to same or different species which on being sensed by the neighbouring plant lead to triggering of herbivore defence mechanism (Arimura et al., 2000; Engelberth



et al., 2004; Kessler et al., 2006; Frost et al., 2007; Ton et al., 2007).

Though this mechanism is very efficient in triggering herbivore defense system in neighbouring plants but authentication of this mechanism cannot be guaranteed in every case as is seen in *Manduca sexta* infested *Nicotiana attenuata* in which VOCs released on being stimulated by herbivory failed to elicit herbivore defense system in the neighbouring *Nicotiana attenuate* (Paschold et al., 2006) while VOCs emitted from sagebrush (*Artemisia tridentata tridentata*) successfully initiated a defense system in *Nicotiana attenuata* against the attack by *Manduca sexta* (Kessler et al., 2006). The cause of this variability is still to be investigated.

The behaviour of sending warning signals to the neighbour seems very peculiar since there is no way that a damaged plant would be advantaged by any means by sending warning signals to its neighbouring plants telling them to watch out for the ensuing herbivore attack when on one side it is engrossed in a constant battle with its neighbouring plants competing for the limited amount of nutrients and water that they share. Plants seem to have evolved this signalling system involving VOCs for communication within an individual plant to protect the undamaged plant parts from herbivore attack but coincidentally this acts as a boon for the neighbouring plants also as they sense the VOCs secreted by the damaged plant though the concentration of VOCs goes on fading as distance increases (Karban et al., 2006).

5.5.5 ROLE OF VOCs IN ABIOTIC STRESS

Plants have developed an efficient system of dealing with the environmental fluctuations which defends them against all the odds that tend to hamper plant growth and development. This defense system is mediated by VOCs.

The very first event that occurs within a plant following a stress perception is the oxidative burst involving production of a large amount of ROS which causes oxidative damage and triggers the signalling cascades which serve to give rise to a number of mechanisms that further pave way for stress tolerance. The plant responds to ROS accumulation in two ways:

- The interplay of reactive oxygen species and reactive nitrogen species allows the instigation of programmed cell death, disturbance in the ion fluxes including Ca^{+2} and direct killing of pathogens. Salicylic acid and abscisic acid act as mediators in these responses in feedback with ROS and RNS.
- Another signalling cascade involves the production of ethylene and jasmonic acid

which are required for resistance to necrotrophic pathogens.

6. GROWING AGITATION: EFFECT OF GLOBAL ENVIRONMENTAL CHANGE IN EMISSION OF VOCs

Anthropogenic activities are not a cause of concern just for the human beings but are also posing a menace to the plants. The emission rates of the very compounds responsible for the sustenance of plants by aiding in plant reproduction, defense and communication are fluctuating rapidly due to increased global warming, elevated carbon dioxide concentrations, precipitation patterns and tropospheric ozone. Global climatic change is not just a problem for the humans, but is also posing to be a great menace to the survival of plants. It can have even more far reaching and catastrophic side effects than ever thought of by anyone.

The above mentioned factors can modulate effective means of plant communication using VOCs by perturbing at two levels. Firstly, by modulating the rate of emission of VOCs. This may happen in case of tropospheric ozone, increased carbon dioxide, increased temperature (Llusia and Penuelas, 2000; Loreto and Schnitzler, 2010) due to global warming and drought which are perceived as stress condition by the plants and thus cause increased emission of induced VOCs in plants. Moreover, increased carbon dioxide and temperature may lead to increased rates of synthesis of VOCs and their volatility and diffusivity is also expected to increase owing to increased temperature (Monson et al., 1992). However, if these stress conditions persist for long, it might lead to decreased production of VOCs because of the reduced metabolic flux into the pathways regulating synthesis of VOCs. Drought may lead to closure of stomata as an adaptation to reduce the transpiration due to evaporation thus reducing the rate of emission of VOCs (Gerard Farré-Armengola, Iolanda Filella, Joan Llusia, Josep Penuelasa, 2012). Secondly, the above written compounds can modify the activity of VOCs once VOCs are released from plants. Ozone can affect at both the steps, in the first step ozone mediated damage to the plant causes emission of stress induced VOCs thus altering the overall volatile profile of plants while in the second step ozone reacts with the already released VOCs from the plants thereby reducing their lifetime (McFrederick et al., 2008; Blande et al., 2010) and modifying them thus altering the manner of the perception of VOCs by pollinators and giving rise to an altogether new cascade which will ultimately affect the reproductive fitness of the plant (Heiden et al., 1999; Vuorinen et al., 2004a).



7. FUTURE PROSPECTS: METABOLIC ENGINEERING OF PLANT VOLATILES

Metabolic engineering aims at achieving two targets:

a) Manipulating the volatilome of those plants in which pollination is limited owing to low amounts of specific component which might act as an attractant for pollinators and thereafter increasing its proportion in the volatile profile of the plant.

b) Manipulating the volatilome of those plants in which production rates have declined due to lack of a key component/components which play key role in the defense system of plants by attracting predators which feed on plant eating insects following herbivory.

Thus, this newly introduced technique seems like a light at the end of the tunnel in enhancing the production of those economically important crops where agriculturists had completely abandoned hopes. Many tactics have been used including the introduction of new gene(s) and manipulation of existing pathways by down/upregulation of certain steps or by occluding the rival pathways.

7.1 ADVANCES IN METABOLIC ENGINEERING

7.1.1 POLLINATION

a) The first consequence of metabolic engineering of floral VOCs on pollinator attraction was scrutinized in transgenic tobacco *Nicotiana attenuata* which showed that decreased amount of benzyl acetone attracted scarce number of hawkweeds and humming birds for pollination (Kessler et al., 2008).

b) Latent scent bouquet overexpressing Arabidopsis PAP1 transcription factor in rose flowers was easily perceived by honeybees thus demonstrating its role in pollinator attraction (Zvi et al., 2012).

7.1.2 DEFENSE

a) Introduction of gene coding for patchulol along with some other sesquiterpenes in transgenic tobacco, overexpressing *Pogostemon cablin* patchulol synthase (Wu et al., 2006) dissuaded the hornworms thus improving plant defense.

b) Overexpression of Linalool synthase gene (FaNES1) targeted to chloroplast leading to higher concentration of linalool in Arabidopsis successfully pushed back the aphid *Myzus persicae* thus contributing a great deal to its defense (Aharoni et al., 2003).

c) Overexpression of FaNES1 gene in mitochondria leading to increased production of (3S)-(E)-nerolidol and (E)-DMNT in Arabidopsis contributed to plant defense by attracting predatory mites (Kappers et al., 2005).

d) Overexpression of (E)- β -caryophyllene synthases in rice and maize plant leading to increased production of (E)- β -caryophyllene which contributed a great deal to both above and below ground plant defense by attracting parasitoid wasps and entomopathogenic nematodes that feed on root pests (Degenhardt et al., 2009a).

7.1.3 FRUIT FLAVOUR AND AROMA

Fruit flavour and aroma is a major determinant in attracting animals for dispersal of seeds thus aiding in increased production rates. Successful attempts have been made in tomato to improve its aroma by expressing geraniol synthase (GES) under the polygalacturonase promoter thus leading to production of transgenic fruits with improved flavor and stronger aroma (Davidovich-Rikanati R, Sitrit Y, Tadmor Y, Iijima Y, Bilenko N, Bar E, Carmona B, Fallik E, Dudai N, Simon JE et al., 2007).

In spite of the large number of achievements that metabolic engineering has achieved, some unintended side effects that come up along with the desired effect have been a cause of concern for the phytologists.

7.2 UNINTENDED SIDE EFFECTS OF METABOLIC ENGINEERING OF PLANT VOLATILES

a) Negative effect on plant growth and development:

- Due to decreased carbon availability for essential metabolites.
- Toxicity of newly expressed compounds (Aharoni et al., 2003, 2006; Orolava et al., 2009).
- Very low or no yields of the desired compound owing to insufficient amount of precursors for its biosynthesis (Guterman et al., 2006).
- Formation of unintended compounds as a result of diabolical metabolical activities of the host plant (Lewinsohn & Gijzen, 2009).

b) Certain ecological complications might also creep in along with the desired effect as seen in case of Cucurbita pepo var. texana, in which emission rates of 1, 4 dimethoxybenzene was experimentally increased to aid in pollination by attracting squash bee population, but apart from fulfilling its desired effect it also acted as a powerful stimulus for florivorous beetles which damaged the plant (Theis and Adler, 2012).

A deeper understanding of plant and insect metabolomics and transcriptomics can help us in understanding of the mechanisms controlling plant-insect interactions and thus help in disencumbering unintended effects of metabolic engineering of plant



volatiles by achieving desired effects like increased pollination rates while minimizing pest attraction and herbivory. Insects can prove to be a boon rather than bane for plants provided that effective regulation of emission timing of VOCs is achieved not just being concerned about the emission quantity.

REFERENCES

1. Aharoni A, Giri AP, Deuerlein S, Griepink F, de Kogel WJ, Verstappen FW, Verhoeven HA, Jongsma MA, Schwab W, Bouwmeester HJ (2003): Terpenoid metabolism in wild-type and transgenic *Arabidopsis* plants. *Plant Cell*. 15, 2866–2884.
2. Anten PR et al. (2005): Effects of mechanical stress and plant density on mechanical characteristics, growth, and lifetime reproduction of tobacco plants. *Am Nat*. 166, 650–660.
3. Apel K, Hirt H (2004): Reactive oxygen species: metabolism, oxidative stress, and signal transduction. *Annu Rev Plant Biol*. 55, 373–399.
4. Arimura G, Matsui K, Takabayashi J, (2009): Chemical and molecular ecology of herbivore-induced plant volatiles: proximate factors and their ultimate functions. *Plant Cell Physiol*. 50, 911–923.
5. Arimura GI, Garms S, Maffei M, Bossi S, Schulze B, Leitner M, Mithoefer A, Boland W, (2008a): Herbivore-induced terpenoid emission in *Medicago truncatula*: concerted action of jasmonate, ethylene and calcium signalling. *Planta*. 227, 453–464.
6. Arimura GI, Kopke S, Kunert M, Volpe V, David A, Brand P, Dabrowska P, Maffei, ME, Boland W (2008b): Effects of feeding *Spodoptera littoralis* on lima bean leaves: IV. Diurnal and nocturnal damage differentially initiate plant volatile emission. *Plant Physiol*. 146, 965–973.
7. Baker HG (1977): Non-sugar chemical constituents of nectar. *Apidologie*. 8, 349–356.
8. Bhattacharjee S (2005): Reactive oxygen species and oxidative burst: roles in stress, senescence and signal transduction in plants. *Curr Sci*. 89, 1113–1121.
9. Boatright J, Negre F, Chen XL, Kish CM, Wood B, Peel G, Orlova I, Gang D, Rhodes D, Dudareva N (2004): Understanding in vivo benzenoid metabolism in petunia petal tissue. *Plant Physiol*. 135, 1993–2011.
10. Bolwell GP, Bindschedler LV, Blee KA, Butt VS, Davies DR, Gardner SL, Gerrish C, Minibayeva F (2002): The apoplastic oxidative burst in response to biotic stress in plants: a three-component system. *J Exp Bot*. 53, 1367–1376.
11. Chittka L, Raine NE (2006): Recognition of flowers by pollinators. *Curr Opin Plant Biol*. 9, 428–435.
12. Corpas FJ, Barroso JB, del Rio LA (2001): Peroxisomes as a source of reactive oxygen species and nitric oxide signal molecules in plant cells. *Trends Plant Sci*. 6, 145–150.
13. de Kroon H (2007): Ecology. How do roots interact. *Science*. 318, 1562–1563.
14. Degenhardt J, Hiltbold I, Kollner TG, Frey M, Gierl A, Gershenson J, Hibbard BE, Ellersieck MR, Turlings TCJ. (2009) a. Restoring a maize root signal that attracts insect-killing nematodes to control a major pest. *PNAS, USA*. 106, 13213–13218.
15. del Rio LA, Sandalio LM, Corpas FJ, Palma JM, Barroso JB (2006): Reactive oxygen species and reactive nitrogen species in peroxisomes. Production, scavenging, and role in cell signaling. *Plant Physiol*. 141, 330–335.
16. Dicke M & Loreto F (2010): Induced plant volatiles: from genes to climate change. *Trends Plant Sci*. 15-3, 115–117.
17. Dicke M & van Loon JJA (2000): Multitrophic effects of herbivore-induced plant volatiles in an evolutionary context. *Entomol Exp Appl*. 97, 237–249.
18. Dobson HEM (2006): Relationship between floral fragrance composition and type of pollinator. *Biology of Floral Scent*. CRC Press, Boca Raton, pp. 147–198.
19. Dobson HEM, Bergström G (2000): The ecology and evolution of pollen odors. *Plant Syst Evol*. 222, 63–87.
20. Dobson HEM, Groth I, Bergström G (1996): Pollen advertisement: chemical contrasts between flower and pollen odors. *Am J Bot*. 83, 877–885.
21. Dotterl S, Jurgens A, Seifert K, Laube T, Weissbecker B, Schutz S (2006): Nursery pollination by a moth in *Silene latifolia*: the role of odours in eliciting antennal and behavioural responses. *New Phytologist*. 169, 707–718.
22. Dudareva N (2005): Plant volatiles: from compounds to metabolic pathways and their regulation. *Abstr Pap Am Chem Soc*. 230, U155.
23. Engelberth J, Alborn HT, Schmelz EA, Tumlinson JH (2004): Airborne signals prime plants against insect herbivore attack. *PNAS, USA*. 101, 1781–1785.
24. Fischbach RJ, Staudt M, Zimmer I, Rambal S, Schnitzler JP (2002): Seasonal pattern of monoterpene synthase activities in leaves of the evergreen tree *Quercus ilex*. *Physiologia Plantarum*. 114, 354–360.
25. Flamini G, Cioni PL, Morelli I (2002): Differences in the fragrances of pollen and different floral parts of male and female flowers of *Laurus nobilis*. *J Agric Food Chem*. 50, 4647–4652.
26. Foyer CH, Noctor G (2005a): Oxidant and antioxidant signalling in plants: a re-evaluation of the concept of oxidative stress in a physiological context. *Plant Cell Environ*. 28, 1056–1071.
27. Foyer CH, Noctor G, (2005b): Redox homeostasis and antioxidant signaling: a



- metabolic interface between stress perception and physiological responses. *Plant Cell*. 17, 1866–1875.
28. Franklin KA (2008): Shade avoidance. *New Phytol*. 179, 930–944.
29. Gruter C, Ratnieks FL (2011): Flower constancy in insect pollinators: adaptive foraging behaviour or cognitive limitation. *Commun Integr Biol*. 4, 633–636.
30. Hargreaves AL, Harder LD, Johnson SD (2009): Consumptive emasculation: the ecological and evolutionary consequences of pollen theft. *Biol Rev*. 84, 259–276.
31. Henning JA, Teuber LR (1992): Combined gas-chromatography electroantennogram characterization of alfalfa floral volatiles recognized by honey bees (Hymenoptera, Apidae). *J Econ Entomol*. 85, 226–232.
32. Hermsmeier D, Schittko U, Baldwin IT (2001): Molecular interactions between the specialist herbivore *Manduca sexta* (Lepidoptera, Sphingidae) and its natural host *Nicotiana attenuata*. I. Large-scale changes in the accumulation of growth- and defense-related plant mRNAs. *Plant Physiol*. 125, 683–700.
33. Holopainen JK & Gershenzon J (2010): Multiple stress factors and the emission of plant VOCs. *Trends Plant Sci*. 15(3), 176–184.
34. Holopainen JK (2004): Multiple functions of inducible plant volatiles. *Trends Plant Sci*. 9, 529–533.
35. Horiuchi J et al (2007): The floral volatile, methyl benzoate, from snapdragon (*Antirrhinum majus*) triggers phytotoxic effects in *Arabidopsis thaliana*. *Planta*. 226, 1–10.
36. Jabalpurwala FA, Smoot JM, Rouseff RL (2009): A comparison of citrus blossom volatiles. *Phytochem*. 70, 1428–1434.
37. Kant MR, Ament K, Sabelis MW, Haring MA, Schuurink RC (2004): Differential timing of spider mite-induced direct and indirect defenses in tomato plants. *Plant Physiol*. 135, 483–495.
38. Karban R, Shiojiri K, Huntzinger M and McCallAC (2006): Damage induced resistance in sagebrush: volatiles are key to intra- and interplant communication. *Ecology*. 87, 922 – 930.
39. Kesselmeier J, Ciccioli P, Kuhn U, Stefani P, Biesenthal T, Rottenberger S, Wolf A, Vitullo M, Valentini R, Nobre A, Kabat P & Andreae MO (2002): *Global Biogeochem Cycles*. 16, 11–26.
40. Kesselmeier J, Staudt M (1999): Biogenic volatile organic compounds (VOC): an overview on emission, physiology and ecology. *J Atmos Chem*. 33, 23–88.
41. Kessler D, Gase K, Baldwin IT (2008): Field experiments with transformed plants reveal the sense of floral scents. *Science*. 32, 1200–1202.
42. Knudsen JT, Tollsten L (1991): Floral scent and intrafloral scent differentiation in *Monoses* and *Pyrola* (Pyrolaceae). *Plant Syst Evol*. 177, 81–91.
43. Koeduka T, Fridman E, Gang DR, Vassao DG, Jackson BL, Kish CM, Orlova I, Spassova SM, Lewis NG, Noel JP, Baiga TJ, Dudareva N, Pichersky E (2006): Eugenol and isoeugenol, characteristic aromatic constituents of spices, are biosynthesized via reduction of a coniferyl alcohol ester. *PNAS, USA*. 103, 10128–10133.
44. Kunze J, Gumbert A (2001): The combined effect of colour and odor on flower choice behavior of bumble bees in flower mimicry systems. *Behav Ecol*. 12, 447–456.
45. Kuzma J, Fall R (1993): Leaf isoprene emission rate is dependent on leaf development and the level of isoprene synthase. *Plant Physiol*. 101, 435–440.
46. Lin C, Owen SM, Penuelas J (2007): Volatile organic compounds in the roots and rhizosphere of *Pinus* spp. *Soil Biol & Biochem*. 39, 951–960.
47. Loivamaki M, Louis S, Cinege G, Zimmer I, Fischbach RJ, Schnitzler JP (2007): Circadian rhythms of isoprene biosynthesis in grey poplar leaves. *Plant Physiol*. 143, 540–551.
48. Loreto F, Fischbach RJ, Schnitzler JP, Ciccioli P, Brancaleoni E, Calfapietra C, Seufert G (2001) a: Monoterpene emission and monoterpene synthase activities in the Mediterranean evergreen oak *Quercus ilex* L. grown at elevated CO₂ concentrations. *Global Change Biology*. 7, 709–717.
49. Matsui, K (2006): Green leaf volatiles: hydroperoxide lyase pathway of oxylipin metabolism. *Curr Opin Plant Biol*. 9, 274 – 280.
50. Minnesota Department of Health-<http://www.health.state.mn.us/divs/eh/indoorair/voc/>
51. Navrot N, Rouhier N, Gelhaye E, Jacquot JP (2007): Reactive oxygen species generation and antioxidant systems in plant mitochondria. *Physiol Plant*. 129, 185–195.
52. Negre F, Kish CM, Boatright J, Underwood B, Shibuya K, Wagner C, Clark DG, Dudareva N (2003): Regulation of methylbenzoate emission after pollination in snapdragon and petunia flowers. *Plant Cell*. 15, 2992–3006.
53. Niinemets U et al. (2004): Physiological and Physico-chemical controls on foliar volatile organic compound emissions. *Trends Plant Sci*. 9, 180–186.
54. Nishida N et al. (2005): Allelopathic effects of volatile monoterpenoids produced by *Salvia leucophylla*: inhibition of cell proliferation and DNA synthesis in the root apical meristem of *Brassica campestris* seedlings. *J. Chem. Ecol*. 31, 1187–1203.
55. Owen S, Boissard C, Street RA, Duckham SC, Csiky O, Hewitt CN (1997): Screening of 18 Mediterranean plant species for volatile organic compound emissions. *Atmospheric Environment*. 31, 101–117.
56. Owen, SM, Boissard C, Hewitt CN (2001): Volatile organic compounds (VOCs) emitted from 40 Mediterranean plant species: VOC



- speciation and extrapolation to habitat scale. *Atmospheric Environment*. 35, 5393–5409.
57. Pandey S, Tiwari SB, Upadhyaya KC, Sopory SK (2000) Calcium signaling: linking environmental signals to cellular functions. *Crit Rev Plant Sci*. 19, 291–318.
58. Pandhair V, Sekhon BS (2006): Reactive oxygen species and antioxidants in plants: an overview. *J Plant Biochem Biotechnol*. 15, 71–78.
59. Paré P W & Tumlinson J H (1997): De novo biosynthesis of volatiles induced by insect herbivory in cotton plants. *Plant Physiol*. 114, 1161–1167.
60. Pichersky E, Noel JP, Dudareva N (2006): Biosynthesis of plant volatiles: nature's diversity and ingenuity. *Science*. 311, 808–811.
61. Pierik R et al. (2004): Canopy studies on ethylene-insensitive tobacco identify ethylene as a novel element in blue light and plant–plant signalling. *Plant J*. 38, 310–319.
62. Pott MB, Hippauf F, Saschenbrecker S, Chen F, Ross J, Kiefer I, Slusarenko A, Noel JP, Pichersky E, Effmert U et al. (2004). Biochemical and structural characterization of benzenoid carboxyl methyltransferases involved in floral scent production in *Stephanotis floribunda* and *Nicotiana suaveolens*. *Plant Physiol*. 135, 1946–1955.
63. Runyon JB et al. (2006): Volatile chemical cues guide host location and host selection by parasitic plants. *Science*. 313, 1964–1967.
64. Schiestl FP, Ayasse M. (2001): Post-pollination emission of a repellent compound in a sexually deceptive orchid: a new mechanism for maximising reproductive success. *Oecologia*. 126, 531–534.
65. Schluter PM, Xu S, Gagliardini V, Whittle E, Shanklin J, Grossniklaus U, Schiestl FP. (2011): Stearoyl-acyl carrier protein desaturases are associated with floral isolation in sexually deceptive orchids. *PNAS, USA* 108, 5696–56701.
66. Shiojiri K, Kishimoto K, Ozawa R, Kugimiya S, Urashimo S, Arimura G, Horiuchi J, Nishioka, T, Matsui K, Takabayashi J (2006): Changing green leaf volatile biosynthesis in plants: an approach for improving plant resistance against both herbivores and pathogens. *PNAS, USA*. 103, 16672–16676.
67. Staudt M, Bertin N (1998): Light and temperature dependence of the emission of cyclic and acyclic monoterpenes from holm oak (*Quercus ilex* L.) leaves. *Plant Cell and Environment*. 21, 385–395.
68. Stephenson AG (1981): Toxic nectar deters nectar thieves of *Catalpa speciosa*. *Am Midl Nat*. 105, 381–383.
69. Theis N, Adler LS (2012): Advertising to the enemy: enhanced floral fragrance increases beetle attraction and reduces plant reproduction. *Ecology*. 93, 430–435.
70. Theis N & Lerdau M (2003): The evolution of function in plant secondary metabolites. *Int J Plant sci*. 164, 93–102.
71. Tingey DT, Manning M, Grothaus LC, Burns WF. (1980): Influence of light and temperature on monoterpene emission rates from Slash Pine. *Plant Physiol*. 65, 797–801.
72. van Schie, CCN, Haring MA, Schuurink, RC (2006): Regulation of terpenoid and benzenoid production in flowers. *Curr Opin Plant Biol*. 9 (2), 203–208.
73. Vassao DG, Gang DR, Koeduka T, Jackson B, Pichersky, E, Davin, LB, Lewis NG, (2006): Chavicol formation in sweet basil (*Ocimum basilicum*): cleavage of an esterified C9 hydroxyl group with NAD(P)H-dependent reduction. *Organic & Biomolecular Chemistry*. 4, 2733–2744.
74. von Helversen O, Winkler L, Bestmann HJ (2000): Sulphur-containing “Perfumes” attract flower-visiting bats. *J Comp Physiol A*. 186, 143–153.
75. Waelti MO, Muhlemann JK, Widmer A, Schiestl FP (2008): Floral odor and reproductive isolation in two species of *Silene*. *J Evol Biol*. 21, 111–121.
76. Wilkinson MJ, Owen SM, Possell M, Hartwell J, Gould P, Hall A, Vickers C, Hewitt CN (2006): Circadian control of isoprene emissions from oil palm (*Elaeis guineensis*). *Plant J*. 47, 960–968.
77. Wolfe LM. (2002): Why alien invaders succeed: support for the escape-from-enemy hypothesis. *Am Naturalist*. 160, 705–711.
78. Wright GA, Lutmerding A, Dudareva N, Smith BH. (2005): Intensity and the ratios of compounds in the scent of snapdragon flowers affect scent discrimination by honeybees (*Apis mellifera*). *J Comp Physiol A Neuroethol Sens Neural Behav Physiol*. 191, 105–114.
79. Wu SQ, Schalk M, Clark A, Miles RB, Coates R, Chappell J (2006): Redirection of cytosolic or plastidic isoprenoid precursors elevates terpene production in plants. *Nat Biot*. 24, 1441–1447.
80. Wu JQ, Baldwin IT (2009): Herbivory-induced signaling in plants: perception and action. *Plant Cell Environ*. 32, 1161–1174.
81. Xu S, Schluter PM, Grossniklaus U, Schiestl FP (2012): The genetic basis of pollinator adaptation in a sexually deceptive orchid. *PLoS Genetics*. 8, 1002889.
82. Yakir E, Hilman D, Harir Y, Green RM (2007): Regulation of output from the plant circadian clock. *FEBS Journal*. 274, 335–345.
83. Youngsteadt E, Nojima S, Haberlein C, Schulz S, Schal C (2008): Seed odor mediates an obligate ant-plant mutualism in amazonian rainforests. *PNAS, USA*. 105, 4571–4575.
84. Zvi MM, Shklarman E, Masci T, Kalev H, Debener T, Shafir S, Ovadis M, Vainstein A. (2012). PAPI transcription factor enhances production of phenylpropanoid and terpenoid



scent compounds in rose flowers. New Phytologist. 195, 335–345.

85. Pichersky E, Noel JP, Dudareva N (2006): *Biosynthesis of plant volatiles: nature's diversity and ingenuity. Science. 311, 808–811.*
86. *Chapter 16: Emission and Function of Volatile Organic Compounds in Response to Abiotic Stress* By Francesco Spinelli, Antonio Cellini, Livia Marchetti, Karthik Mudigere Nagesh and Chiara Piovene DOI: 10.5772/24155.



A STUDY ON CUSTOMER PREFERENCE TOWARDS GOLD JEWELLERY WITH SPECIAL REFERENCE TO COIMBATORE CITY

M. Nambu Gayathiri

*Student of III B.com (PA), Department of Commerce with Professional Accounting,
Dr. NGP College of Arts and Science (Autonomous), Coimbatore*

Dr. S. Suguna

*Associate Professor, Department of Commerce with Professional Accounting,
Dr. NGP College of Arts and Science (Autonomous), Coimbatore*

ABSTRACT

Customer preference is defined as the subjective taste of individual customers measured by their satisfaction with those items after they purchase them. This satisfaction is often referred to as utility. Customer value can be determined by how customer utility compares between different items. Note that preference are independent of Income and Prices. Ability to purchase goods does not determine a customers likes or dislikes. One can have a preference for purchases over affords but only have the financial means to drive afford. The customer has to set a preference and values whose determine are outside Economics.

KEYWORDS : *Customer preference, Gold Jewellery, Buying behavior, Simple percentage, Likert, Rank.*

INTRODUCTION

Marketing refers to activities a company undertakes to promote the buying or selling of a product or service. Marketing includes advertising, selling, and delivering product to consumer or other business. Some marketing is done by affiliate on behalf of a company. Customer preference is defined as the subjective taste of individual customer, measured by their satisfaction with those items after they we purchased them. This satisfaction is often referred to as utility. Customer value can be determined by how customer utility compares between different items.

STATEMENET OF THE PROBLEM

Gold jewellery is most popular among south Indian women. In southern part of India, gold is considered auspicious and a status symbol of women and also men.

Jewellery is not only purpose of showing the status sometimes they used for emergency purpose. Now a day young generation people are totally avoiding the heavy traditional jewellery, because they looking at trendy, contemporary jewellery. These there is a need to study the different purchasing behaviour and preference of the people. Hence the researcher has undertaken preference towards finding the customers preference towards gold jewellery in Coimbatore city.

OBJECTIVES

- To understand the buying behaviour of the customer
- To study the social- economic status of the customers
- To study about their choice on gold jewellery.



- To determine the preference level of customer towards gold jewellery.
- To determine the factors influencing the customer preference towards gold jewellery.

- The study was focused only in the Coimbatore city.
- Finding of the study purely depends upon the responses given by respondents.

SCOPE OF THE STUDY

This study covers a period of six months with the project work done on “Gold jewellery’s in Coimbatore city”. This survey focus on the opinion of the respondents regarding gold jewellery.

RESEARCH DESIGN

The research design refers to the overall strategy that you choose to integrate the different components of the study in a coherent and logical way.

DESCRIPTIVE RESEARCH

Descriptive research is a study designed to depict the participate in an accurate way. It is typically concerned with determining the frequencies with something occur or determining the degree to which variables is associated.

RESEARCH METHODOLOGY

The study is based on a survey collected in Coimbatore city with the help of primary data and secondary data.

PRIMARY DATA

In primary data collection, the data has been collected by using method of questionnaires. Questionnaires was the main tool used for collecting the information from the respondents.

SECONDARY DATA

Secondary data was collected from various possible records like, books, magazines and web site, article ...

TOOLS AND TECHNIQUES

- Rank analysis
- Likert scale analysis
- Percentage analysis

AREA OF THE STUDY

The study was undertaken in Coimbatore.

SAMPLE SIZE

The study was conducted with a sample size of 120 respondents in Coimbatore city.

LIMITATION

- The study is limited to 120 respondents.

REVIEW OF LITEATURE

S. PRAVEEN KUMER (2019),” Buying behavior of customer towards gold jewellery in purchasing behavior and accept the change as concluded that gold has resale cost and make gold benefit and asset for buyers, and it is a essential value in numerous. Culture and buying gold is consider as it is a symbol of wealth of art in India.

AJAY KIRSHANA.G& M. NANDHINI (2017), “entitled as “brand preference and purchase intention towards gold jewellery with special reference to school teacher to Kottayam district.” “The study attempts to calculate the customer purchase intention and brand preference towards gold jewellery. The study makes use of primary and secondary data. The result explain that teacher are motivated to purchase gold jewellery because of the social status, variety brand name, word of mouth publicity, advertisement, price etc....also found that.

SHAHANA PARVEEN, DEEPA SAXENA (2016), entitled as “A study on buying behaviour of woman towards gold jewellery in Rewa City”. Consumer behaviour refers to how and why people make the purchase decisions they do. The benefits of buying gold jewellery are many in number. There are vast number of good available for purchase, but consumers tend to attribute this volume to the industrial world’s massive capacity.

DATA ANALYSIS AND INTERPRETATION

The chapter deals with the analysis and interpretation of the study “A study on customer’s preference towards gold jewellery ‘s with special reference to Coimbatore city” based on that data’s are collected. The data have been analyzed using the following statistical tools.

- Simple percentage analysis
- Likert scale analysis
- Ranking analysis

SIMPILE PERCENTAGE ANALYSIS

The percentage analysis is mainly to find the distribution of different categories of respondents. As the value expressed in percentage it facilities comparison and standardization. This analysis



describes the classification of the respondents filling under each category.

FORMULA

$$\text{Percentage} = \text{Number of Respondents} / \text{Total number of respondents} \times 100$$

TABLE 1
TABLE SHOWING GENDER OF THE RESPONDENTS

S.NO	GENDER	NO. OF RESPONDENTS	PERCENTAGE
1	Male	63	52.5
2	Female	57	47.5
	TOTAL	120	100

(Source: Primary data)

INTERPRETATION

In the above table.1 shows that (52.5%) 63 respondents are male, and (47.5%) 57

- ❖ Majority (52.5%) 63 respondents are female.

LIKERT SCALE ANALYSIS

Likert scale's are a common rating format for survey. Respondents rank quality from depth or best to worst using five or seven levels. Likert items are used to respondents attitude to a particular question or

statement. To analysis the data, it is availability coded as follows.

- 0 5 = Highly Satisfied
- 0 4 = Satisfied
- 0 3 = Dissatisfied
- 0 2 = Highly dissatisfied

FORMULA

$$\text{Likert scale} = \frac{\sum fx}{\text{Total no. of respondents}}$$

While,

f = No. of respondents

x = Likert scale value

$\sum (fx)$ = Total score

TABLE 2
TABLE SHOWING LEVEL OF PREFERENCE OF THE RESPONDENTS TOWARDS PRICE FOR GOLD JEWELLERY

S.NO	PRICE	NO.OF RESPONDENTS	LIKERT SCALE VALUE(X)	TOTAL (FX)
1	HIGHLY SATISFIED	65	5	325
2	SATISFIED	14	4	56
3	NETRUAL	11	3	33
4	DISSATISFIED	17	2	34
5	HIGHLY DISSATIFIED	13	1	13
	TOTAL	120	15	461

(Source : Primary data)

LIKERT SCALE VALUE =

$$\begin{aligned} & \frac{\sum (fx)}{\text{No. of Respondents}} \\ & = \frac{461}{120} \\ & = 3.84 \end{aligned}$$

INTERPRETATION

Likert scale value is 3.84. So, the customer Highly satisfied with price.

RANK CORRELATION

The Kari Pearson's method is based on the assumption that population being student is normal or when the shape of the destruction is not known, there is need for a measure of correlation. It does not matter which wat the items are ranked, item number one may be the largest or it be smallest using ranks rather than actual observation gives the coefficient rank correlation.

**TABLE 3**

FACTORS	I	II	III	IV	V	VI	TOTAL SCORE	FINAL RANK
PRICE	24(6)	10(5)	14(4)	15(3)	26(2)	31(1)	378	VI
WASTAGE	12(6)	22(5)	8(4)	19(3)	20(2)	39(1)	350	V
ADVERTISEMENT	17(6)	17(5)	19(4)	31(3)	23(2)	13(1)	415	II
QUALITY	21(6)	18(5)	19(4)	14(3)	22(2)	26(1)	404	IV
OFFERS AND DISCOUNTS	21(6)	25(5)	14(4)	20(3)	30(2)	10(1)	407	III
DESIGN	23(6)	14(5)	33(4)	12(3)	10(2)	28(1)	424	I

INTERPREATION

Table 3, it is understood that the respondents are given the first rank to the factor of price, they are given second rank to the factor of advertisement, they are given third rank of the factor of offers and discounts, they are given the fourth rank of the factor of quality, they are given the fifth rank of the factor of design, they are given the sixth rank of the factor of wastage.

In this study the respondents are given first rank to the factor of price.

FINDINGS, SUGGESTIONS AND CONCLUSION**FINDINGS****SIMPLE PERCENTAGE ANALYSIS**

- Majority (52.5%) 63 respondents are female.
- Majority (50.0%) 60 respondents are 25-40 years age group.
- Majority (60%) 72 respondents are married people.
- Majority (44.6%) 53 respondents are higher secondary.
- Majority (58.33%) 70 respondents are private employee.
- Majority (53.33%) 64 respondents are don't have a own house.
- Majority (38.33%) 46 respondents are 20001-40001 salary.
- Majority (65.83%) 79 respondents are Rural area.
- Majority (57.5%) 69 respondents are Nuclear family.
- Majority (52.5%)63 respondents are 3-5 family members.
- Majority (66.67%) 80 respondents are interest to investment in gold jewellery.
- Majority (31.67%) 38 respondents are getting information about gold jewellery form neighbour.

- Majority (40.83%) 49 respondents are once year purchase gold jewellery.
- Majority (45.83%) 55 respondents are reason for buying gold jewellery is fashion.
- Majority (46.67%)56 respondents are expectation about gold jewellery is price.
- Majority (66.67%)80 respondents are willing to pay more for design and quality.
- Majority (52.5%)63 respondents are never make a comparison between branded store and local dealers.
- Majority (55.83%)67 respondents are prefer branded store.
- Majority (79.17%)95 respondents are making a jewellery purchase for gift propose.
- Majority (31.67%)38 respondents are influenced by dealers.
- Majority (41.67%)50 respondents are financial constraints.

LIKERT SCALE ANALYSIS

- Likert scale value is 3.84, So the customers are highly satisfied with price
- Likert scale value is 3.8, So the customers are satisfied with design.
- Likert scale value is 3.1, So the customers are neutral with wastage.
- Likert scale value is 2.88, So the customers are highly dissatisfied with quality.

RANK ANALYSIS

- In this study the respondents are given the first rank to the design of jewellery.

SUGGESTIONS

- The respondents are suggested to reduce the wastage of gold jewellery.
- The respondents are interest to purchase the different design.



CONCLUSION

The study mainly focused on customer preference towards gold jewellery. Gold jewellery buying is no longer confined to seasonal cycles of marriages. Diwali and Christmas, anytime is a fine time and gold jewellery can be bought as much to express an emotions, as to proclaim the financial status of the wearer. The customers preference shows a shift from content to design in gold jewellery i.e. fashionable gold jewellery is the range nowadays and acquires a status symbol in their minds. Marketing is a very important aspects in business and it contributes greatly to the success o the gold jewellery store. Gold jewellery consumption in India has been traditionally driven by the strong cultural affinity for gold. Gold jewellery an integral part of weddings culture in India, and is considered as a necessity with demand, especially in south India. Gold jewellery demand has also supported by the increasing appetite for gold jewellery rural and non-urban markets which constitute a major chunk of the total consumption. Gold has also served as a means of saving especially for the rural sector, owing to the lack of any major alternative investment option supported by its anti-inflationary characteristics. This study will provide more information to buyer's to make them take informal decisions optimally.

REFERENCE

1. S. PRAVEEN KUMER (2019), "*A study on buying behaviour of consumers towards gold jewellery in Tamil Nadu*", volume-7, issue 1, Jan 2019,95-102, ISSN Print: 2347-4564and ISSN online: 2321-88781.
2. G. AJAY KRISHNAN (2017), "*A study on consumers brand preference and purchase intention towards gold jewellery with special reference to school teachers in Kottayam district.*" Volume – 8, issue 12 Dec 2017, PP- 278-286, ISSN (print)-09766308 and ISSN (online)-0976-6316.
3. SHAHANA PARVEEN and Dr. DEEPA SAXENA (2016), "*A study on buying behaviour of woman towards gold jewellery in Rewa city.*" Volume-6,issue-6 June 2017,ISSN (online)-2394-1537,ISSN (print)- 2394-1529



A STUDY ON FINANCIAL PERFORMANCE OF CEMENT INDUSTRY WITH SPECIAL REFERNCE TO ACC LIMITED

V. Abinethra

*Student of III B.Com(PA), Department of Commerce with Professional Accounting,
Dr. N. G. P Arts and Science College, Coimbatore*

Mrs. P. Dhanya

*Assistant Professor, Department of Commerce with Professional Accounting,
Dr. N. G. P Arts and Science College, Coimbatore*

ABSTRACT

Indian cement is the second largest in the world after China. Whereas, ACC Limited is one of India's leading manufacturers of cement and ready mix concrete. The primary objective of this analysis is to study the financial performance and to know the Profitability position, Liquidity position and the changes in working capital of ACC limited for the period of five years (2014-18). The look has been conducted and the analysis has been made with the assist of financial statements acquired from the economic database and the financial position has been revealed as findings, provides suggestions for improving the position of the company and final statement has concluded in this study after ratio analysis and differencing the changes in the working capital of the company of the defined years.

KEYWORDS-*ACC limited, Financial performance, Ratio analysis, Liquidity ratio, Profitability ratio, Working capital.*

INTRODUCTION

Finance is a broad time period that describe activities associated with banking, leverage or debt, credit, capital markets, money and investments. Basically, finance represents cash management and the manner of acquiring wished funds. Financial overall performance is a subjective measure of how properly a company can use assets from its primary mode of commercial enterprise and generate measure of a firm's overall monetary fitness over a given period. Financial analysis involves the usage of financial statistics to assess a agency's performance and make tips approximately how it may improve going forward. Financial analysis primarily perform their work in excel, the usage of a spreadsheet to investigate

historical statistics and make projections of ways they think the organization will carry out in the future.

STATEMENT OF THE PROBLEM

The problem of the analysis is to decide the economic ratio evaluation and to earn enough profit to control the proper functioning of ACC limited. The comparative evaluation technique determines the profitability and financial overall performance of a business through comparing economic statements of or extra time periods. The performance of business is measured by using the quantity of profit earned. The more the profit, the more efficient is the business. An attempt has been made to analyze the financial performance of the business of ACC limited.



SCOPE OF THE STUDY

The scope pertains to the financial performance of the ACC limited. Financial analysis is the process of determining the operating and financial structure of a firm from accounting and financial statements. The look has been conducted with the assist of financial statements acquired from the economic database. The financial statement of the business enterprises are balance sheet and profit and loss account pertaining to 5 years. The purpose of analysis is to determine the efficiency, performance of the business enterprise and management and its profitability reflected in the financial records and reports.

OBJECTIVES OF THE STUDY

1. To study the financial performance of ACC limited.
2. To know the Profitability and Liquidity position of the concern.
3. To know the changes over working capital for the period of five years (2014-18).

RESEARCH METHODOLOGY

- **SOURCE OF DATA**
Secondary data
- **PERIOD OF STUDY**
For the period of 5 years from 2014-2018
- **TOOLS AND TECHNIQUES**
RATIO ANALYSIS
 - **Liquidity ratio**
 - Current ratio
 - Liquid ratio
 - Absolute liquid ratio
 - **Profitability ratios**
 - Gross profit ratio
 - Net profit ratio
 - Operating profit ratio
 - Operating ratio

WORKING CAPITAL LIMITATIONS

- The end result of the study are relevant best for ACC cement limited and it can not be used in another company.
- The study has been confined most effective to the period of five years.
- The data used are secondary in nature and any bias in them is reflected in the analysis and conclusion of the study.

REVIEW OF LITERATURE

K.T. Gopi (2018), "The study on financial performance of cement industry in India" in this study mistreatment Extended Dupont approach of leading cement firms like ACC, Gujarat Ambuja and Ultra tech cement for the period 2006-2015. This approach has stressed on analysis of Return on Equity (ROE). This approach has shown the decline in the profitability of leading cement firms throughout the period and it can be inferred that the monetary performance of all three companies appears to be similar as measured by ROE with minimal deviation among companies.

Er. Suhaib Firdous and Er. Anzar Hamid (2017), "Workability of concrete" on his experiment by the use of various sorts of water cement ratio, the form of aggregate influence workability angular and rough aggregate reduce workability. Small size aggregate provide outstanding surface areas than huge size aggregate and provide more quantity of water for lubrication. Whereas, the temperature on which the concrete mix is prepared affect its workability the slump of concrete blend decreases whilst temperature increases and determine that the proper quantity of water ought to be mixed according to the form and size of aggregate.

P. Devika Sabarirajan (2017), "A study on financial performance of cement industry with special reference to ACC limited" the assignment monitor that the liquidity is satisfactory and can meet its short term liabilities and they can also fulfill the long term liabilities as the company have strong solvency ratio. The overall performance of the company is green and ACC cement limited should focus on profitability through modernizing production over retaining good supply chain management strategy.

DATA ANALYSIS AND INTERPRETATION RATIO ANALYSIS

Ratio analysis is the comparison of line items in the financial statements of a business. Ratio analysis is used to evaluate a number of issues with an entity, such as its liquidity, efficiency of operations, and profitability. Ratio analysis is less useful to corporate insiders, who have better access to more detailed operational information about the organization.

**LIQUIDITY RATIO**

Liquidity ratios are an important class of financial metrics used to determine a debtor's ability to pay off current debt obligations without raising external capital. Liquidity ratios measure a company's ability to pay debt obligations and its margin of safety through the calculation of metrics including the current ratio, liquid ratio, and absolute liquid ratio.

- Current ratio
- Liquid ratio

- Absolute liquid ratio

CURRENT RATIO

The current ratio measures a company's ability to pay off its current liabilities (payable within one year) with its current assets such as cash, accounts receivable and inventories. The higher the ratio, the better the company's liquidity position.

$$\text{Current Ratio} = \text{Current Asset} / \text{Current Liabilities}$$

TABLE 1**TABLE SHOWING CURRENT RATIO****(Rupees in crores)**

YEAR	CURRENT ASSETS	CURRENT LIABILITIES	CURRENT RATIO
2014	1,976.76	3,407.81	0.58
2015	1,767.89	3,616.98	0.49
2016	1,969.38	4,003.49	0.49
2017	4,799.30	5,293.03	0.91
2018	6,416.31	5,330.56	1.20

*(Source: 5 years annual report of ACC limited)***INTERPRETATION**

The above table 1 shows that the current ratio in the year 2014 was 0.58 and then it moves downwards to 0.49 in the year 2015 and it remains constant in the year 2016 and it moves upwards to 0.91 in 2017 and finally in the year 2018 it raised to 1.20. The normal current ratio is 2:1. The above table shows current ratio

lower than 2 in all financial year. This shows that the company is not enjoying credit worthiness.

LIQUID RATIO

The quick ratio measures a company's ability to meet its short-term obligations with its most liquid assets and therefore excludes inventories from its current assets. It is also known as the "acid-test ratio"

$$\text{Liquid Ratio} = \text{Liquid Assets} / \text{Current Liabilities}$$

TABLE 2**TABLE SHOWING LIQUID RATIO****(Rupees in crores)**

YEAR	LIQUID ASSETS	CURRENT LIABILITIES	LIQUID RATIO
2014	720.38	3,407.81	0.21
2015	578.46	3,616.98	0.16
2016	744.75	4,003.49	0.19
2017	3,394.52	5,293.03	0.64
2018	5,274.38	5,330.56	0.99

*(Source: 5 years annual report of ACC limited)***INTERPRETATION**

The above table 2 shows that the liquid ratio of ACC limited in 2014 is 0.21 and it reduces to 0.16 during the year 2015 and increased year by year to 0.19 in 2016, 0.64 in 2017 and 0.99 in 2018. The normal liquid ratio is 1:1.

ABSOLUTE LIQUID RATIO

Absolute liquid ratio extends the logic further and eliminates accounts receivable (sundry debtors and bills receivables) also. Though receivables are more liquid as comparable to inventory but still there may be



doubts considering their time and amount of realization. Therefore, absolute liquidity ratio relates cash, bank and marketable securities to the current liabilities. Since absolute liquidity ratio lays down very strict and exacting standard of liquidity, therefore,

acceptable norm of this ratio is 50%. It means absolute liquid assets worth one half of the value of current liabilities are sufficient for satisfactory liquid position of a business. However, this ratio is not as popular as the previous two ratios discussed.

Absolute Liquid Ratio = Absolute Liquid Assets / Liquid Liabilities

TABLE 3

TABLE SHOWING ABSOLUTE LIQUID RATIO

(Rupees in crores)

YEAR	ABSOLUTE LIQUID RATIO	CURRENT LIABILITIES	ABSOLUTE LIQUID RATIO
2014	309.78	3,407.81	0.09
2015	94.03	3,616.98	0.03
2016	278.4	4,003.49	0.07
2017	2,728.55	5,293.03	0.52
2018	4,647.73	5,330.56	0.87

(Source: 5 years annual report of ACC limited)

INTERPRETATION

In the above table 3 the absolute liquid ratio is 0.09 in 2014 and reduced to 0.03 then increased to 0.07 and hikes during the year 2017 to 0.52 and 0.87 in 2018. The ratio is below 1 and hence the company needs more than its cash reserve to pay-off its current debt.

equity over time, using data from a specific point in time.

- Gross profit ratio
- Net profit ratio
- Operating profit ratio
- Operating ratio

PROFITABILITY RATIOS

Profitability ratios are a class of financial metrics that are used to assess a business's ability to generate earnings relative to its revenue, operating costs, balance sheet assets, and shareholders'

GROSS PROFIT RATIO

Gross profit ratio (GP ratio) is a profitability ratio that shows the relationship between gross profit and total net sales revenue. It is a popular tool to evaluate the operational performance of the business. The ratio is computed by dividing the gross profit figure by net sales.

Gross Profit Ratio = Gross Profit / Sales × 100

TABLE 4

TABLE SHOWING GROSS PROFIT

(Rupees in crores)

YEAR	GROSS PROFIT	SALES	GROSS PROFIT RATIO
2014	8,938.54	11,738.79	76.15
2015	7,014.57	11,797.16	59.46
2016	5,779.28	11,167.55	51.75
2017	5,996.93	13,285.13	45.14
2018	5,728.16	15,657.55	36.58

(Source: 5 years annual report of ACC limited)

**INTERPRETATION**

The table 4 shows the relationship between the gross profit and net sales in percentage. In 2014 the gross profit was 76.15% and the gross profit decreases year by year to 59.46% in 2015, 51.75% in 2016, 45.14% in 2017 and 36.58% in 2018. During the study period the average gross profit position was 53.8%. However the company maintains a good gross profit ratio.

NET PROFIT RATIO

Net profit ratio (NP ratio) is a popular profitability ratio that shows relationship between net profit after tax and net sales. It is computed by dividing the net profit (after tax) by net sales. For the purpose of this ratio, net profit is equal to gross profit minus operating expenses and income tax. All non-operating revenues and expenses are not taken into account because the purpose of this ratio is to evaluate the profitability of the business from its primary operations.

$$\text{Net Profit Ratio} = \text{Net Profit} / \text{Sales} \times 100$$

TABLE 5**TABLE SHOWING NET PROFIT RATIO****(Rupees in crores)**

YEAR	NET PROFIT	SALES	NET PROFIT RATIO
2014	1,150.67	11,738.79	9.80
2015	575.55	11,797.16	4.88
2016	595.72	11,167.55	5.33
2017	913.49	13,285.13	6.88
2018	1,363.52	15,657.55	8.71

*(Source: 5 years annual report of ACC limited)***INTERPRETATION**

The above table 5 shows the relationship between the net profit and net sales in percentage. In 2014 the net profit is at 9.80% and decreased to 4.88% during 2015 and increased to 5.33% in 2016, 6.88% in 2017 and 8.71% in 2018. During the study period the average net profit position was 7.1% and is in decreasing trend.

OPERATING PROFIT RATIO

Operating profit ratio establishes a relationship between operating Profit earned and net revenue generated from operations (net sales). Operating profit ratio is a type of profitability ratio which is expressed as a percentage. Net sales include both Cash and Credit Sales, on the other hand, Operating Profit is the net operating profit i.e. the Operating Profit before interest and taxes. Operating Profit ratio helps to find out Operating Profit earned in comparison to revenue earned from operations.

$$\text{Operating Profit Ratio} = \text{Operating Profit} / \text{Sales} \times 100$$

TABLE 6**TABLE SHOWING OPERATING PROFIT RATIO****(Rupees in crores)**

YEAR	OPERATING PROFIT	SALES	OPERATING PROFIT RATIO
2014	1,513.29	11,738.79	12.89
2015	1,537.43	11,797.16	13.03
2016	1,420.73	11,167.55	12.72
2017	1,912.43	13,285.13	14.40
2018	2,412.78	15,657.55	15.41

(Source: 5 years annual report of ACC limited)

**INTERPRETATION**

The above table 6 shows that the operating profit ratio is 12.89% in year 2014 and keeps fluctuating in the upcoming years to 13.03% in 2015, 12.72% in 2016, 14.40% in 2017 and the current year 2019 ratio increased to 15.41%. So the company should decrease their expense to increase their profit.

OPERATING RATIO

The operating ratio shows the efficiency of a company's management by comparing the total operating expense (OPEX) of a company to net sales. The operating ratio shows how efficient a company's management is at keeping costs low while generating revenue or sales. The smaller the ratio, the more efficient the company is at generating revenue vs. total expenses.

$$\text{Operating Ratio} = \text{Cost of Goods Sold} + \text{Operating Expenses} / \text{Sales} \times 100$$

TABLE 7**TABLE SHOWING OPERATING RATIO****(Rupees in crores)**

YEAR	OPERATING PROFIT RATIO	OPERATING RATIO
2014	12.89	87.11
2015	13.03	86.97
2016	12.72	87.28
2017	14.4	85.6
2018	15.41	84.59

(Source: 5 years annual report of ACC limited)

INTERPRETATION

From the above table 7, it is clear that operating profit is consistently good. The operating profit in 2014 is 87.11% and fluctuates year by year to 86.97% in 2015, 87.28% in 2016, 85.6% in 2017 and in the year 2018 it is 84.59% and it has to decrease their expenses to increase profit.

WORKING CAPITAL

Working capital, also known as net working capital (NWC), is the difference between a company's current assets, such as cash, accounts receivable (customers' unpaid bills) and inventories of raw materials and finished goods, and its current liabilities, such as accounts payable. Net operating working capital is a measure of a company's liquidity and refers to the difference between operating current assets and operating current liabilities.



Working Capital = Current Assets – Current Liabilities

Table 8
TABLE SHOWING THE SCHEDULE OF CHANGES IN WORKING CAPITAL FOR THE YEAR ENDED 2014 - 2015

(Rupees in Crores)

PARTICULARS	2014	2015	INCREASE	DECREASE
Current Assets				
Inventories	1,256.38	1,189.43		66.95
Sundry Debtors	410.6	484.43	73.83	
Cash and Bank	309.78	94.03		215.75
Loans and Advances	1,697.82	1,990.99	293.17	
Total (A)	3,674.58	3,758.88		
Current Liabilities				
Current liabilities	3,407.81	3,616.98		209.17
Provisions	1,053.21	759.19	294.02	
Total (B)	4,461.02	4,376.17		
Working capital (A-B)	-786.44	-617.29		
Net increase in working capital	169.15			169.15
Total	-617.29	-617.29	661.02	661.02

(Source: Secondary Data)

INTERPRETATION

Current asset during 2014, 2015 is Rs.3,674.58 and Rs.3,758.88 respectively. The current asset increases by Rs.84.3. A current liability during 2014, 2015 is Rs.4,461.02 and Rs.4,376.17 respectively. The current liability decreases by Rs.84.85.

INFERENCE

Net increase in working capital is Rs.169.15.



Table 9
TABLE SHOWING THE SCHEDULE OF CHANGES IN WORKING CAPITAL FOR THE YEAR ENDED 2015-2016

(Rupees in Crores)

PARTICULARS	2015	2016	INCREASE	DECREASE
Current Assets				
Inventories	1,189.43	1,224.63	35.20	
Sundry Debtors	484.43	466.35		18.08
Cash and Bank	94.03	278.4	184.37	
Loans and Advances	1,990.99	1,969.38		21.61
Total (A)	3,758.88	3,938.76		
Current Liabilities				
Current liabilities	3,616.98	4,003.49		386.51
Provisions	759.19	738.74	20.45	
Total (B)	4,376.17	4,742.23		
Working capital (A-B)	-617.29	-803.47		
Net decrease in working capital		186.18	186.18	
Total	-617.29	-617.29	426.20	426.20

(Source: Secondary Data)

INTERPRETATION

Current asset during 2015, 2016 is Rs.3,758.88 and Rs.3,938.76 respectively. The current asset increased by Rs.179.88. A current liability during 2015, 2016 is Rs.4,376.17 and Rs.4,742.23 respectively. The current liability increases by Rs.366.06.

INFERENCE

Net decrease in working capital is Rs.186.18



Table 10
TABLE SHOWING THE SCHEDULE OF CHANGES IN WORKING CAPITAL FOR THE YEAR ENDED 2016-2017

(Rupees in Crores)

PARTICULARS	2016	2017	INCREASE	DECREASE
Current Assets				
Inventories	1,224.63	1,404.78	180.15	
Sundry Debtors	466.35	665.97	199.62	
Cash and Bank	278.4	2,728.55	2,450.15	
Loans and Advances	1,969.38	2,402.27	432.89	
Total (A)	3,938.76	7,201.57		
Current Liabilities				
Current liabilities	4,003.49	5,293.03		1,289.54
Provisions	738.74	193.98	544.76	
Total (B)	4,742.23	5,487.01		
Working capital (A-B)	-803.47	1,714.56		
Net decrease in working capital		2,518.03		2,518.03
Total	-803.47	-803.47	3,807.57	3,807.57

(Source: Secondary Data)

INTERPRETATION

Current asset during 2016, 2017 is Rs.3,938.76 and Rs.7,201.57 respectively. The current asset increases by Rs.3262.81. A current liability during 2017, 2018 is Rs.4,742.23 and Rs.5,487.01 respectively. The current liability increases to Rs.744.78.

INFERENCE

Net decrease in working capital is Rs.2518.03.



Table 11
TABLE SHOWING THE SCHEDULE OF CHANGES IN WORKING CAPITAL FOR THE YEAR ENDED 2017-2018

(Rupees in Crores)				
PARTICULARS	2017	2018	INCREASE	DECREASE
Current Assets				
Inventories	1,404.78	1,141.93		262.85
Sundry Debtors	665.97	626.65		39.32
Cash and Bank	2,728.55	4,647.73	1,919.18	
Loans and Advances	2,402.27	3,131.09	728.82	
Total (A)	7,201.57	9,547.40		
Current Liabilities				
Current liabilities	5,293.03	5,330.56		37.53
Provisions	193.98	258.49		64.51
Total (B)	5,487.01	5,589.05		
Working capital (A-B)	1,714.56	3,958.35		
Net increase in working capital	2,243.79			2,243.79
Total	3,958.35	3,958.35	2,648.00	2,648.00

(Source: Secondary Data)

INTERPRETATION

Current asset during 2017, 2019 is Rs.7,201.57 and Rs.9,547.40 respectively. The current asset increases by Rs.2345.83. A current liability during 2017, 2019 is Rs.5,487.01 and Rs.5,589.05 respectively. The current liability increases by Rs. 102.04.

INFERENCE

Net increase in working capital is Rs.2243.79.

FINDINGS, SUGGESTION AND CONCLUSION

FINDINGS OF THE STUDY

- Current ratio of the company was highest in the year 2018 and lowest in the year 2015 and 2016.
- Liquid ratio, highest in the year 2018 and in the lowest in the year 2015.

- Absolute liquid ratio of the company was highest in the year 2018 and lowest in the year 2015.
- Gross profit of the company was highest in the year 2014 and lowest in the year 2018.
- Net profit of the company was highest in the year 2014 and lowest in the year 2015.
- Operating profit of the company was highest in the year 2018 and lowest in the year 2016.
- Operating ratio of the company was highest in the year 2016 and lowest in the year 2018.
- Working capital was increased in the year 2014 and 2015.
- Working capital was decreased in the year 2015 and 2016.
- Working capital was decreased in the year 2016 and 2017.



- o Working capital was increased in the year 2017 and 2018.

reference to ACC limited” International Journal of Creative Research Thoughts, volume 5(4).

SUGGESTIONS

- The company is able to pay short term obligations and the company has enough quick assets to pay for its current liabilities, so the company has to maintain this further
- The company's day-to-day cash management need to be improved.
- The gross profit margin may be improved by increasing sales price or decreasing cost of sales.
- The company has to improve the efficiency at converting sales into actual profit to enjoy the best profit.
- The company should try to keep the costs lower and increase its sales.
- The company has to maintain change in working capital at a moderate level as decrease in or great increase at change in working capital is not good.

CONCLUSION

The analysis of financial performance of ACC Limited is stated in this report. The liquidity position of the company is satisfactory hence the company can meet out its short term liabilities and have enough quick assets to pay off current liabilities and future it has to maintain day to day cash management to increase the absolute liquid ratio alone. However the profitability position of the company is not much better, that the company has to decrease the cost of production and keep the cost lower or increase sales price and also need to improve the efficiency in converting sales into actual profit. The change in working capital should be increased without decreasing and has to maintain the change in working capital at a moderate position.

REFERANCE

1. K.T. Gopi (2018), “The study on financial performance of cement industry in India” *Asian Journal of Managerial Science* volume 7, no.2, pp. 16-20.
2. Er. SuhaibFirdous and Er.Anzar Hamid (2017), “Experimental study of Workability of concrete by using various types of water cement ratio” *International Journal of Creative Research Thoughts*, volume 5(3).
3. P. DevikaSabarirajan (2017), “A study on financial performance of cement industry with special



A STUDY ON BRAND LOYALTY OF CUSTOMER TO SELECT THE MILK BRAND WITH SPECIAL REFERENCE TO COIMBATORE CITY

Loksanjit.P.K

*Student of III B.com (PA), Department of Commerce with Professional Accounting,
Dr. NGP College of Arts and Science (Autonomous), Coimbatore*

Dr. K. Vanaja

*Professor and Head of the Department, Department of Commerce with Professional Accounting,
Dr. NGP College of Arts and Science (Autonomous), Coimbatore*

ABSTRACT

Brand loyalty is the tendency of consumers to continuously purchase one brand's products over another. Consumer behavior patterns demonstrate that consumers will continue to buy products from a company that has fostered a trusting relationship. Nowadays, almost all food items contain chemicals and so everyone is in a position to avoid chemicals for their good health. Milk takes an important place in everyone's diet irrespective of age, income or education.

A lot of brands of milk products are available in the market. But the consumers prefer a particular brand which is much affordable to them. The study aims to understand the consumers' brand loyalty towards variable milk and milk products from the respondents in Coimbatore using simple percentage, likert scale, rank analysis. Both primary and secondary data is used and sampling is collected from 120 respondents through convenient sampling method. The researchers have taken the packaged milk products of Aavin, Aroky, Aroma and Sakthi for the research. The main objective is to study the consumer behaviour and the factors influencing the brand, brand awareness, problems and level of satisfaction of the consumer in purchasing various brands of milk and milk products.

KEYWORDS-*Milk brand, Brand loyalty, Customer Simple percentage analysis, Likert scale analysis, Rank analysis.*

INTRODUCTION

Brand loyalty is defined as positive feelings towards a brand and dedication to purchase the same product or service repeatedly now and in the future from the same brand, regardless of a competitor's actions or changes in the environment. It can also be demonstrated with other behaviours such as positive word-of-mouth advocacy. Brand loyalty is where an individual buys products from the same manufacturer repeatedly rather than from other suppliers. Businesses whose financial and ethical values, for example ESG responsibilities, rest in large part on their brand loyalty are said to use the loyalty business model.

STATEMENT OF PROBLEM

Nowadays, almost all food items contain chemicals and so everyone is in a position to avoid chemicals for their good health. Milk takes an important place in everyone's diet irrespective of age, income or education. So people prefer quality milk for their family health and also it is convenient for storage and cost effective. A company should differentiate its brand very clearly from other brands. It is very important for the company's success. When the perceived value of consumers is positive and satisfied with the product quality, they are ready to give more price for their preferred brand. This study attempts to identify the



factors that affect brand loyalty of aavin, aroky, aroma and sakhi milk consumers and also observe the behavior of loyal consumers.

SCOPE OF THE STUDY

A lot of brands of milk products are available in the market. But the consumers prefer a particular brand which is much affordable to them. In the modern business world, due to the development of science and technology, many new brands have been introduced in the market every year. Measures of brand preference attempt to quantify the impact of marketing activities in the hearts and minds of customers and potential customers. Higher brand preference usually indicates more revenues (sales) and profit, also making it an indicator of company financial performance. The study aims to understand the consumers' brand loyalty towards variable milk products from the respondents of in Coimbatore. The researchers have taken the packaged milk products of Aavin, Aroky, Aroma and Sakthi for the research.

OBJECTIVE OF THE STUDY

- To study the consumer behaviour towards selected particular brands of milk and milk products.
- To identify the factors influencing the brand of the consumer.
- To identify the brand awareness, problems and level of satisfaction of the respondents in purchasing of various brands of milk and milk products.

RESEARCH METHODOLOGY

SOURCE OF DATA

The study includes both primary and secondary data.

- Primary data respondents concerned and collected by using predefined questionnaire
- Secondary data is collected from the various articles, journals and websites.

SAMPLE DESIGN

The sample design used to collect data from the respondent is convenient sampling.

SAMPLE SIZE

The sample size which take for the study is 120.

TOOLS USED FOR DATA ANALYSIS

- Simple Percentage Analysis
- Ranking Correction
- Likert Scale Analysis

LIMITATION OF THE STUDY

- The study is carried out on a certain period and hence it is influenced by prevailing factors during the period
- The data is collected only from Coimbatore city
- Limited tools has been used to interpret the data collected

REVIEW OF LITERATURE

Dhananjay Bapat et.al (2016), This study examined the relation between brand experience and brand evaluations and studied how brand evaluations influence brand loyalty. The study from the Indian contest would benefit both academia and marketing managers. Future researchers can test the model for the specific set of products/service categories and specific set of customers. Researchers can also explore the relation among various brand experience dimensions and other brand constructs. Based on the study, it is suggested that brand managers place emphasis on affective cognitive brand experience as it influences overall brand evaluation.

N.Elangovan, et.al (2015), The study elaborated how individuals makes decision to spend their available resources (time, money, effort) on consumption related items. Consumers lifestyles are influenced by numbers of factors. Like culture, subculture, values, demographic factors, social status, reference group, household and also the internal makeup of the consumers, which are emotions, personality motives of buying, perception and learning. Consumers are also influenced by the marketing activities. The researchers suggested to arrange standard discount rate, credit facility, more festival season offers, periodical market research and more refrigerator facility.

Kameswara Rao Poranki (2015), The researcher of this paper focuses on the brand preference and its linkage to customer satisfaction by considering the various aspects of Customer Satisfaction of branded Milk in India. The research has found out the Customer satisfaction through brand preferences of the consumers of the Nandini Shubham Milk. The piece of research is concluded that the customers of the Bangalore City of India are satisfied with the Nandini Shubham Milk and they still needs good offers and discounts as well as quality product in future days. The Nandini Shubham Milk is a good product it can fulfill the requirement or expectation of the customers in their mind. Due to non-availability of this brand in many places, the customers are unable to buy even though it is good according to them. Therefore, the company has to focus on better distribution channels to cover various parts of Bangalore, India.



DATA ANALYSIS AND INTERPRETATION

Rank analysis

In this chapter the analysis and interpretation of the “A Study on impact of celebrity advertisements in the sales promotion of Reliance trends (With special reference to Coimbatore city)”, is presented based on the opinion of sample of 120 respondents selected from Coimbatore city through a questionnaire containing 20 questions were analysed through

SIMPLE PERCENTAGE METHOD

Simple percentage analysis is carried out for most of all questions given in the questionnaire. This analysis describes the classification of respondents failing each category. The percentage analysis is mainly used for standardization and comparisons are support with the analysis.

Simple percentage analysis
Likert scale

FORMULA

$$\text{Percentage} = \text{Number of respondents} / \text{Total respondents} \times 100$$

TABLE 1
TABLE SHOWING GENDER OF THE RESPONDENTS

S. NO.	GENDER	NO. OF RESPONDENTS	PERCENTAGE
1	Male	60	50
2	Female	60	50
	TOTAL	120	100

(Source: Primary data)

INTERPRETATION

The above table shows that 50% of the respondents are Male and 50% of respondents are Female

from collective responses to set pf items, and the format in which responses are scored along a range. Technically speaking a Likert scale refers only to the former.

INTERFACE

Majority, 50% of the respondents are Male and 50% of the respondents are Female.

When responding to a Likert questionnaire item, respondents specify their level of agreement or disagreement on a systematic agrees- disagrees scale for a series of statements. Thus, the range captures the intensity of their feelings for a given item.

LIKERT SCALE ANALYSIS

A LIKERT SACLE is a psychometric scale commonly used in research employing questionnaires.

Self- reporting is the most widely used approach to scaling responses in survey research. The term is often used inter changeably wit rating scale, or more accurately the LIKERT- TYPE SCALE, even though the two are not anonymous. The scale is named after its inventor, psychologist Rensislikert. Likert distinguished between a scale proper, which emerges

FORMULA

$$\text{Likert Scale} = \frac{\sum(fx)}{\text{Total number of respondents}}$$

f = Number of respondents
(fx) = Total score

MID- VALUE

Mid- value indicates the middle most value of Likert scale.



TABLE 2
TABLE SHOWS THE LEVEL OF SATISFACTION OF THE FEATURES IN MILK BRANDS (TASTE)

S. NO	FACTORS	NO. OF RESPONDENTS	LIKERT SACLE VALUES(x)	TOTAL
1	Highly satisfied	54	5	270
2	Satisfied	49	4	196
3	Neutral	14	3	42
4	Dissatisfied	0	2	0
5	Highly Dissatisfied	3	1	3
	TOTAL	120		511

(Source: Primary data)

$$\begin{aligned} \text{Likert scale} &= \frac{\sum(fx)}{\text{Total number of respondents}} \\ &= \frac{511}{120} \\ &= 4.2 \end{aligned}$$

INTERPRETATION

Likert scale value 4.2 which is greater than the mid value 3, so the customers are satisfied with the taste of the milk.

RANK ANALYSIS

A rank analysis is any of several statistics that measure an ordinal association, the relationship between ranking of different ordinal variables or different ranking of the same variables, where a "ranking" is the assignment of the labels "first", "second", "third", etc to different observation of a particular variable. A rank analysis measures of similarity between two rankings, and can be used to assess the significance of the relation between them. It is not necessarily a total order of object because two different objects can have the same ranking. The rankings themselves are totally ordered.

TABLE 3
TABLE SHOWS THE FACTORS OF THE MILK BRAND

S.NO	PARTICULARS	1	2	3	4	5	6	7	8	TOTAL SCORE	RANK
1	Quality	44(8) 352	18(7) 126	10(6) 60	20(5) 55	5(4) 20	6(3) 18	5(2) 10	12(1) 12	653	1
2	Taste	14(8) 112	30(7) 210	21(6) 126	5(5) 25	17(4) 68	6(3) 18	10(2) 20	17(1) 17	596	2
3	Packing	12(8) 96	15(7) 105	33(6) 198	13(5) 65	13(4) 52	6(3) 18	12(2) 24	16(1) 16	574	4
4	Convenience	16(8) 128	13(7) 91	20(6) 120	15(5) 75	15(4) 60	17(3) 51	10(2) 20	14(1) 14	559	5
5	Quantity	14(8) 112	20(7) 140	21(6) 126	20(5) 100	5(4) 20	15(3) 45	13(2) 26	12(1) 12	581	3
6	Freshness	15(8) 120	16(7) 112	20(6) 120	11(5) 55	8(4) 32	15(3) 45	22(2) 44	13(1) 13	541	7
7	Home delivery	12(8) 96	15(7) 105	22(6) 132	13(5) 65	14(4) 56	10(3) 30	8(2) 16	20(1) 20	520	8
8	Price	15(8) 120	14(7) 98	16(6) 96	18(5) 90	17(4) 68	8(3) 24	19(2) 38	13(1) 13	547	6

(Source: Primary data)



INTERPRETATION

The above table shows that the Quality is rank 1, taste is rank 2, Quantity is rank 3, Packing is rank 4, Convenience is rank 5, Price is rank 6, Freshness is rank 7, Homedelivery is rank 8.

INTERFACE

Quality is ranked 1 based on the respondents ranking towards the factors of the milk brand.

FINDINGS, SUGGESTIONS AND CONCLUSION

FINDINGS

SIMPLE PERCENTAGE

- Majority, 50% of the respondents are Male and 50% of the respondents are Female.
- Majority, 47% of the respondents are 21- 30 years.
- Majority, 73% of the respondents are Undergraduates.
- Majority, 80% of the respondents are Unmarried.
- Majority, 48% of the respondents are Private Employees.
- Majority, 38% of the respondents are earning Rs 10,000 – Rs 20,000.
- Majority, 38% of the respondents are Nuclear family.
- Majority, 47% of the respondents are aware of the milk brand for more than 4 years.
- Majority, 39% of the respondents came to know about the milk brand by Advertisements.
- Majority, 33% of the respondents of the use Aavin milk brand
- Majority, 39% of the respondents prefer Aavin.
- Majority, 41% of the respondents visit Occasionally.
- Majority, 42% of the respondents consume below 1 liter of milk.
- Majority, 39% of the respondents says Easy availability.
- Majority, 33% of the respondents are using the present milk brand for above 4 tears.
- Majority, 46% of the respondents like Organised retail shops
- Majority, 35% of the respondents continue the same.

LIKERT SCALE

- Likert scale value 4.2 which is greater than the mid value 3, so the customers are satisfied with the taste of the milk.

- Likert scale value 3.5 which is greater than the mid value 3, so the customers are satisfied with the quality.
- Likert scale value 3.5 which is equal to the mid value 3, so the customers are neutral about the price.
- Likert scale value 3.6 which is greater than the mid value 3, so the customers are satisfied with the package.
- Likert scale value 3.6 which is greater than the mid value 3, so the customers are satisfied with the availability of the milk brands.
- Likert scale value 3.6 which is greater than the mid value 3, so the respondents are satisfied with the product range.
- Likert scale value 3.7 which is greater than mid value 3, so the customers are satisfied with the purchase experience.

RANK ANALYSIS

Quality is ranked 1 based on the respondents ranking towards the factors of the milk brand.

SUGGESTIONS

- The respondent suggested to improve the freshness of milk.
- Home delivery service can be increased.
- Adulteration must be avoided.
- Advertisement through various medias can make the customer to recall all the milk brand.

CONCLUSION

Milk is an essential thing that every person including infants and adults prefer. Though vendor milk had acquired the qualities of healthy ,tasty, etc. people in Coimbatore mostly prefer branded milk based on availability, quality, etc. Mostly the branded milk products like Aavin, Arokya, Aroma and Sakthi had attracted the consumers buying behaviour. The Study analysed the problems faced by the consumers in the usage of different brands of milk and found the reasons for switching from one brand to other brand of milk. The future scope for this study could be increasing the brand loyalty of milk Coimbatore.

REFERANCE

1. Dhananjay Bapat et.al (2016), “Exploring Relationship among Brand Experience Dimension, Brand Evaluation and Brand Loyalty”, *Global Business Review*, Volume 17, Issue 6, pp.no.1357-1372.



2. *N.Elangovan, et.al (2015), "A Study on Consumer Behaviour Towards Various Brands of Milk and Milk Products with Special Reference to Thudiyalur Town at Coimbatore District in Tamil Nadu", International Journal of Multidisciplinary Research and Development, Volume 2, Issue 4, pp.no.595-601.*
3. *Kameswara Rao Poranki (2015), "Brand Preference and Customer Satisfaction of Brand Milk in India", The International Journal Research Publication's, Volume 05, Issue 08, pp.no. 202-211*



A STUDY OF WORK PLACE ENVIRONMENTAL PARAMETERS AND OCCASIONAL HEALTH PROBLEMS AMONG WOMEN CONSTRUCTION WORKERS IN COIMBATORE

Hariharan. B

*Student of III B.Com (PA), Department of Commerce with Professional Accounting,
Dr. N.G.P Arts and Science College (Autonomous), Coimbatore*

Dr. M. Kalimuthu

*Assistant Professor, Department of Commerce with Professional Accounting (Autonomous),
Dr. N.G.P Arts and Science College, Coimbatore*

ABSTRACT

Women's health plays an important role in determining the health of the future population because women's health has an inter-generational effect. Finally, a women's health affects the household economic well-being, and as a woman with poor health will be less productive in the labour force. Primary, secondary data and sample techniques is used for the study, sample size – 120 respondents, these are the research methodologies that are been used.

- ✓ *Simple percentage analysis.*
- ✓ *Chi-Squire analysis.*

These are the statistical tools. Majority 52 (43%) are of 18-2 years. The current study aims to address the health status of unorganised women workers in urban Coimbatore with following objectives of the study.

KEY WORDS-*Women's health, Women workers, Construction, Occupation.*

INTRODUCTION

Women's health plays an important role in determining the health of the future population because women's health has an inter-generational effect. Finally, a women's health affects the household economic well-being, and as a woman with poor health will be less productive in the labour force. Because of prevailing culture and traditional practices in India, the health and nutritional status of women are becoming worse. Health condition in one phase of a women's life affect other phases of her life as well as the health and well-being of future generations. The 45th World Health Assembly in (1992) has strongly advocated for a lifespan approach to women's health from conception to old age. It has also called for multicultural action for

women's health, particularly in the areas of raising female literacy, creating opportunities for income generation, increasing the participation of women in national development, and in short, empowering women to make decisions on matters that impact their health.

STATEMENT OF PROBLEM

Nowadays more rural and urban women were going for construction works. The reason for such shift in occupation is reduced agricultural activities due to poor rainfall & cost hike. As the living cost in high to make ends meet women choose alternative jobs. She has to overcome at home, workplace, health problem, family problems, sexual harassment and social issues.



The researcher has noticed many construction workers in Market and Woraiyur and near Tamilnadu police academy. These women seem to be in pressure to identifying the availability of works, distance to be travelled to new workplace, insecurity about work and reaching home late in evening. This influenced the researcher to do research about such women working in construction field. So, the researcher wants to study the problems faced by the construction workers in areas of occupation, social, family and personal aspects.

SCOPE OF STUDY

- To study about the level of parameters and occasional health problems among women construction workers.
- The health awareness of the women workers.

OBJECTIVES

- To examine the socio-economic and demographic background of the study.
- To find out the wage of the women construction workers.
- To see the reason for migration among the migrant women workers.
- To analyze the health problems faced by the respondents.
- To find out the association between the social-economic, occupational, personal and family aspects of women constructions workers.
- To suggest measures to women construction workers to manage their situations.

RESEARCH METHODOLOGY RESEACH DESIGN

Research methodology is as science of studying of how the research is done scientifically and the various ways that are generally adopted by a research problem

SOURCES OF DATA COLLETION

The relevant data was collected from both primary sources and secondary sources. The

starting point of my information gathering hasbeen the secondary sources such as internet, books, and journals and so on.

First, I made a study of the brand positioning and repositioning strategies of fast track watches through secondary sources such as internet, insurance magazines, and journals and so on. Then I conducted a customer awareness survey on brand repositioning strategies undertaken by fast trach watches in recent times.

PRIMARY DATA COLLECTION

Data was collected through an interview schedule, consisting of both open ended and closed ended questions. The schedule covered parameterslike reasons for customers' brand preference; recollection of earlier tagline and advertisement, brand ambassador of fast track; awareness of new tagline and campaign featuring Aamir Khan, new designs and so on. The data was collected through e- mails, telephone contacts and one-to-one personal interviews.

SAMPLING DESIGN

A sample size for the study was determined on the basis of the assumption that the reaction of the people will represent the entire target population. Convenient sampling method is used to select the respondents. The respondents who have been taken for the study, is using the fastrack watch at present.

TOOLS OF ANALYSIS SIMPLE PERCENTAGE ANALYSIS

Simple percentage analysis is one of the statistical tools which is widely used for analysis and interpretation of primary data.it is one of the simple forms of analysis which is very easy for anyone to understand the outcome of the research. It is normally used by commercial research organization.

**FORMULA**

$$\text{PERCENTAGE} = \frac{\text{Number of Respondents}}{\text{Total number of respondents}} \times 100$$

CHI-SQUIRE

The chi-square test is used to test whether the two factors are independent or in other words this is to find whether the one factor has influence over the other. For this purpose, the factors in this study are classified under two groups and chi-square test is applied between the factors of each group with suitable hypothesis. In this study, it was decided to use χ^2 (chi-square) statistical test which was carried out at 5% level of significance to test the statistically significant of the framed hypothesis.

$$\text{The statistic } \chi^2 = \frac{(O-E)^2}{E}$$

Where O-Observed frequency and E-Expected frequency

Degree of freedom = (R-1) (C-1)

WHEN,

R=Row total

C=Column total

LIMITATIONS

1. The study has been restricted to the women workers only.
2. The data and opinion collected are assumed to be objective.
3. The survey is restricted to 120 respondents.
4. Time constraint.
5. The study has been restricted to Coimbatore city only.

REVIEW OF LITERATURE

Zafar Iqbal (2018) conducted a study on the challenges faced by the prospective teachers during teaching practice. The sample of the study comprised 34 prospective teachers enrolled in the final semester of B.Ed. (Hons.) program at University of the Punjab and University of Gujrat. Data analysis revealed that there was a noticeable transformation towards the use of teaching methods other than lecture method in their classroom. The major challenges included dealing with poor physical infrastructure, scarce and underused academic resources, inflexibility in classroom arrangement, non-professional attitude of school

administration, and trying out innovation without challenging the prevailing school norms.

Banu and Kumar (2018) conducted a study on the Working Conditions and Issues of Women Workers in an Unorganized Sector- Special Reference to Construction Sector with 63 women workers in Thuraiyur Taluk, Tiruchirappalli. The data shows that the women construction workers affected by numerous health issues on which 8 of 10 have a urinary tract infection and 66.66% of them suffer from musculoskeletal problems. The lung-related ailments are faced by 57.14% respondents and 92.1% of women workers have an allergic reaction to dust. However, 9 out of 10 women are not having any skin disease.

Rasheedha Banu (2019) Education reforms invariably accord highest priority to improve teacher effectiveness. It requires consistent up gradation of teacher education programmes. It was found that 24% of students were satisfied and 76% of students were not satisfied by the availability of appropriate study materials like according to Two Year B.Ed. Programme in government institutions. Even the teachers and the administrations of respective institutions found great difficulty in their work after this decision.

DATA ANALYSIS AND INTERPRETATION INTRODUCTION

This chapter deals with the analysis and interpretation of study on customer brand preference towards fast-track wrist watch regarding selected brands in Coimbatore. This study has carried out various statistical analysis tools.

SIMPLE PERCENTAGE ANALYSIS

Simple percentage analysis is one of the statistical tools which is widely used for analysis and interpretation of primary data. It is one of the simple forms of analysis which is very easy for anyone to understand the outcome of the research. It is normally used by commercial research organization.

**FORMULA**

$$\text{PERCENTAGE} = \frac{\text{Number of Respondents}}{\text{Total number of respondents}} \times 100$$

TABLE NO: 1
AGE OF THE RESPONDENT

AGE	NO. OF RESPONDENT	PERCENTAGE
18-27	52	43
28-37	31	26
28-37	22	18
28-37	15	13
TOTAL	120	100

INTERPRETATION

This table shows that 52(43%) of the respondents are of 18-27years, 31(26%) respondents are of 28-37 years of age group, 22(12%) of the respondents are of 38-47 years, 15(13%) respondents are above 48 years of age.

It is concluded that majority 52(43%) of the respondents are of 18-27years in age.

CHI-SQUIRE ANALYSIS**CHI-SQUIRE**

The chi-square test is used to test whether the two factors are independent or in other word this is to find whether the one factors has influence over the other. For this purpose, the factors in this study are

classified under two groups and chi-square test is applied between the factors of each group with suitable hypothesis. In this study, it was decided to use χ^2 (chi-square) statistical test which was carried out at 5% level of significance to test the statistically significant of the framed hypothesis.

The statistic χ^2 defined by $\chi^2 = \frac{(O-E)^2}{E}$

Where O-Observed frequency and E-Expected frequency

Degree of freedom = (R-1) (C-1)

WHEN,

R=Row total

C=Colum total

TABLE NO: 2

RELATIONSHIP BETWEEN TYPE OF EMPLOYMENT AND PRIMARY OCCUPATION RESPONDENTS

TYPES OF EMPLOYMENT & PRIMARY OCCUPATION	Seasonal	Regular	TOTAL
FULL TIME	30	22	52
PART TIME	34	34	68
TOTAL	64	56	120

CHI-SQUIRE**RESULT TEST ANALYSIS**

CALCULATED VALUE (χ^2)	DEGREE OF FREEDOM	TABLE VALUE AT 5%	HYPOTHESIS
.915 ^a	1	3.84	INSIGNIFICANCE

INTERPRETATION

Calculated value of chi-square at level of significance is lesser than the table value. Therefore, hypothesis is accepted. Hence it can be concluded that

there is no significant relationship between type of employment and primary occupation respondents.

There is no relationship between type of employment and primary occupation respondents.



FINDINGS, SUGGESTIONS AND CONCLUSION

FINDINGS

PERCENTAGE ANALYSIS

- It is concluded that majority 52(43%) of the respondents are of 18-27years in age.
- It is concluded that majority 71(59%) of the respondents are of Married in marital status.
- It is concluded that majority73(61%) of the respondents are of Owned of house.
- It is concluded that majority 56(47%) of the respondents are One hour enjoy leisure.
- It is concluded that majority 62(52%) of the respondents are Part time of working.
- It is concluded that majority50 (42%) of the respondents are of Monthly wages.
- It is concluded that majority 64(53%) of the respondents are of Seasonal of employment.
- It is concluded that majority 43(36%) of the respondents are of Industrial work off-seasonal.
- It is concluded that majority 48(40%) of the respondents are of Gynecological health of health issues faced.
- It is concluded that majority 47(39%) of the respondents are of Written of agreement for working construction.
- It is concluded that majority 39(33%) of the respondents are of 6-7 hours of sleeping.
- It is concluded that majority 61(51%) of the respondents are of Yes says for medical insurance policy.
- It is concluded that majority 61(51%) of the respondents are of Yes says for met with accident while working.
- It is concluded that majority 44(37%) of the respondents are 10-20 days of unemployment in the last year.
- It is concluded that majority 67(56%) of the respondents are of No says in registered with construction union.
- It is concluded that majority 35(29%) of the respondents are of Society form of savings.
- It is concluded that majority 38(32%) of the respondents are of 2 months in long working the same employer.
- It is concluded that majority 40 (33%) of the respondents are of Friends in time of emergency do approach.

CHI-SQUARE

- There is no relationship between type of employment and primary occupation respondents.
- There is no relationship between enjoy leisure and types of wage respondents.
- There is no relationship between what form do you save and long period of working the same employer respondents.
- There is no relationship between age group respondents and source of income during off-seasonal respondents.

SUGGESTIONS

- The workers are unaware of the first – aid to be provided in case of accidents hence they should be provided awareness about the safety measures and the usage of first – aid box.
- The workers should be provided with life insurance by the employer.
- The wiring in the site with wires should be replaced by electric cables to safeguard from accidents.
- The workers should be provided with safety gears like shoes and goggles.
- The women workers should be provided with medical benefits and rest room facilities.
- The workers should be provided with proper sanitation facilities.
- The workers should be encouraged to save their earnings instead of spending it on alcohol and drugs for the better living conditions.

CONCLUSION

This research has provided the comprehension about the construction workers and the problems faced by them in their work and workplace. The workers are either oblivious or lack knowledge about the safety and welfare measures to be adopted in the workplace. The workers give less or no importance to their health despite of the hazards prevailing in the construction industry. The workers are working very hard for their economic wellbeing but the wages earned are not sufficient to meet their day-to-day living. Moreover, the workers face competition from migrant workers and they are reluctant to work for lower wages unlike their counterparts.

The workplace has to be equipped with proper safety and welfare facilities. The workers have to be given proper awareness about the usage of such facilities and equipment's. The workers, irrespective of



the gender, are prone to many hazards in their occupation. Proper awareness and initiative from both the contractor and the employer will prevent the occupational hazards. The research has proved that the workers' occupational hazards have a direct effect on their personal, economic and social life. Thus, the research has set the milestone for the betterment of the construction workers in their work, workplace and personal life.

REFERENCE

1. **Zafar Iqbal (2018)**, "The challenges faced by the prospective teachers during teaching practice", *Bulletin of Education and Research* Vol. 40, No. 2 pp. 113-136.
2. **Banu and Kumar (2018)** conducted a study on the *Working Conditions and Issues of Women Workers in an Unorganized Sector- Special Reference to Construction Sector with 63 women workers in Thuraiyur Taluk, Tiruchirappalli, International open access journal, volume-2, issue-3.*
3. **RasheedhaBanu (2019)**, "Problems Faced by the Student-Teachers During Two year B.ed. Programme", *Journal of Emerging Technologies and Innovative Research, Volume 6, Issue6, pp.no.688-691.*



ACID FLY ATTACK AMONG THE RESIDENTIAL STUDENTS IN RURAL AREA AT SOUTH OF TAMILNADU

Ms.E.Kalasri

Assistant Lecturer, KMC College of Nursing, Trichy

Mr.K.Jayaprakash

Lecturer, KMC College of Nursing, Trichy

Dr.A.Rajathi

Principal, KMC College of Nursing, Trichy

INTRODUCTION

Paederus dermatitis was first reported in the literature in 1901 by Vorderman, who reported an outbreak of dermatitis in personnel at the Anjet-Kidoel lighthouse in Jawa caused by insects that were known locally as *semoet-kalong*. *Paederus dermatitis* is found in all zoogeographic regions across the world. Sporadic cases are seen in any season when the insect is active, but large outbreaks occur particularly during the rainy months.

PAEDERUS

The species described by Vorderman was *Paederus peregrinus*, believed to be a variety of *Paederus fuscipes*. Various names given for this condition include “*Dermatite vesiculose saisonnière*” (1915), “*Dermatitis linearis*” (1917), “*Rove beetle dermatitis*” (1963), “*Staphylinidae dermatitis*” (1968), “*whiplash dermatitis*” (1954) and spider lick. A study found that dispersal of *P. fuscipes* occurred mainly during rice harvesting, plowing and straw burning due to destruction of habitat and non-availability of food. The *Paederus* group of insects belong to the rove beetle family which is the second largest family of beetles (*Staphylinidae*, *Coleoptera*).



The term *Coleoptera* was given by Aristotle to insects with wing cases, referring to the *koleon* (sheath) and *pteron* (wing). The insects are usually

around 7–13 mm long and are often mistaken for ants. They are brightly colored with metallic blue- or



green-colored and many with bright orange or red on the pronotum and the basal segments of the abdomen.

CASE REPORT

In 2020, January there was an increase in the number of residential students reporting with burning skin lesions. The residential building had large ventilation openings for cross ventilation in the corridors was where students spent most of their time reading with lights in the evening and night hours, which could have acted as an attractant for the flies. The affected rooms and the corridors inspected by the Management team had a high number of flies of different species, both dead and alive. Residents who reported to have been attacked by acid fly and present at the time of investigation were interviewed, and rashes were examined by the experts in the Medical team, for verification and confirmation of diagnosis. Rashes were very much suggestive of acid

fly toxin induced lesions. With the help of residents and the residential building administrators, the investigation team collected dead and live samples of acid flies from the hostel. Most of the residential premises were observed to be kept clean, however there were potential breeding areas. Students giving a history of lesions starting as erythematous swellings with burning sensation which eventually developed into a superficial blister in 24 -48 hours, in a linear pattern or a kissing pattern between flexures, Acid fly attack diagnoses were clinically made. We propose the following criteria for the diagnosis of Paederus dermatitis based on the history and clinical features. Histopathology is not diagnostic and was not included in the criteria. Acute onset eruption with burning or itching sensation, linear or streaky pattern of dermatitis with or without kissing lesions and history of contact with Paederus beetle or patient from an endemic region.



TREATMENT

- The area should be washed with soap and water.
- Tincture iodine topically neutralizes pederin.
- Oral antihistamines may be given. Silver sulfadiazine has antibacterial activity and has been recommended to ameliorate symptoms.
- Soothing agents such as calamine, camphor and topical anesthetics (lidocaine, benzocaine) have been used for temporary

relief of itching and burning sensations. After the appearance of the lesions, topical steroids with or without an antibiotic are effective.

- Qadir recommended a regimen consisting of oral antihistamines, topical steroids and oral ciprofloxacin.
- Topical steroids are given till the skin lesions crust or show signs of healing; this usually takes 7–10 days. Antihistamines are useful for relieving pruritus.



PREVENTION

- Reducing the insect population in the surroundings. Avoidance of contact of insects with human skin.
- Minimizing release of toxin from the insect after it alights on the skin.
- Prevention or reduction of lesions after contact.
- Reduction of Insects in the Surroundings - Primary prevention is by increasing public awareness of the habitat of the insects, their attraction to artificial lights and the manner of exposure to the toxin and prophylactic measures post exposure.
- This is especially important during periods of known outbreaks such as the monsoon season.
- Recommend regular preventive sprays of pyrethroids and 50% malathion in infested areas.
- Minimizing contact of insects with human skin- Windows should be closed before putting on artificial lights in the evenings; this can prevent insects from entering the building, as it has been seen that these insects are most active from 1 h after sunset till midnight.
- Netted screens may be placed on doors and windows to allow ventilation while keeping out insects.
- However, care should be exercised in selecting the appropriate size meshwork, as the insects because of their small girth, can pass through the standard mesh openings of 1.5 mm² as they measure only 1 mm × 0.5 mm in cross-section.
- People in susceptible areas should avoid standing directly under fluorescent lights, especially during the monsoon season.
- In fact, sleeping near fluorescent lights even after they are switched off should also be avoided because that is the time when most of the contacts occur.
- Rooms can be sprayed with insecticide which can also be used to spray the insects when seen; however, care must be taken not to crush the dead beetle which can also release toxin when crushed.
- Use of mosquito nets which may or may not be treated with permethrin is useful to prevent fall of insects while sleeping.
- Insect electrocution devices that use ultraviolet light to attract the insects may be used.
- However, people should avoid staying close to these contraptions to avoid contact with the beetles.
- Insect trapping devices such as sticky traps and glue boards may also be used.
- Pheromone-based baits may be used for monitoring. Insect repellent creams may be used on a short - term basis when working in areas with a heavy load.
- If one needs to work in an area with a high prevalence of beetles, long sleeved shirts and hats would go a long way in preventing contact of the skin with the beetles.
- Home remedies -apply aloe Vera and coconut oil.



CONCLUSION

Our study concluded that *Paederus fuscipes* was the causative agent and it was identified. Top storeys of buildings, illuminated at night, facing potentially wet areas were seen to be affected more. As a preventive measure, the investigating team suggested 'fly proofing' of the entire Hostel building. Residential premises and the swamp area were suggested cleaning on a war-footing, followed by appropriate pyrethroid fogging. Insecticide spraying was advised to be done regularly in the surrounding areas and in the hostel.

REFERENCES

1. Maryam S, Fadzly N, Amirul AAA, Zuharah WF. Attraction factors for *Paederus fuscipes*' dispersal, a vector of *Paederus dermatitis* towards human residential premises. *Rev Inst Med Trop Sao Paulo*. 2017 Apr 3;59:e4.
2. Padhi T, Mohanty P, Jena S, Sirka CS, Mishra S. Clinicoepidemiological profile of 590 cases of beetle dermatitis in western Orissa. *Indian J DermatolVenereolLeprol*. 2007;73(5):333-5.
3. *Insect Bites: Background, Pathophysiology, Epidemiology*. 2018 Jul 26. Available from: <https://emedicine.medscape.com/article/769067-overview>. Accessed on 16 December 2018.
4. *Insect bites and stings*. nhs.uk. 2017. Available at: <https://www.nhs.uk/conditions/insect-bites-and-stings/>. Accessed on 16 December 2018.
5. Singh S, Mann BK. Insect bite reactions. *Indian J DermatolVenereolLeprol*. 2013;79(2):151.



A STUDY ON FINANCIAL PERFORMANCE OF MARUTI SUZUKI MOTORS

V. Gokulapriya

*Student of III B.Com.(PA), Department of Commerce with Professional Accounting,
Dr. N. G. P Arts and Science College, Coimbatore*

Mrs. P. Dhanya

*Assistant Professor, Department of Commerce with Professional Accounting,
Dr. N. G. P Arts and Science College, Coimbatore*

ABSTRACT

Maruti Suzuki India Ltd. primarily manufactures cars and has been the most favorite automobile brand among Indian people since its inception. The main objective of the study is to analyze firm's profitability and liquidity position by using ratio analysis and to know the changes over working capital for the period of four years (2015-19). The company can improve its profitability position by pay off current liabilities. By managing the debtors effectively working capital of the company can be increased.

KEY WORDS-*Financial Performance, Ratio Analysis, Profitability Ratios, Liquidity Ratios, Working Capital.*

INTRODUCTION

At present we cannot imagine a world without finance. It can also describe as finance is the soul of our economic activities. Effective management of business requires control over expense to reduce the cost of operation and to make the business profitable. Assets must be properly maintained to increase their productivity. Liabilities of a business have to be repaid in due time. According to entrepreneurs "finance is concerned with cash. It is so, since, every business transaction involves cash directly or indirectly". It is the vast term. Measuring the results of a firm's policies and operations in monetary terms. These results are reflected in the firms return on investments, return on assets, value added, etc... Financial performance is to calculate key financial ratios over the last three to five years. The ratios can be compared year to year.

STATEMENT OF THE PROBLEM

Being this present status, it quiet possible for the company to improve its profitability as well as liquidity considerable without employing, further resources and just be stream lining the existing

financial system and the financial information system. The basic problem faced by the financial manager of an enterprise in to trade-off between the conflicting and equally improvement goals of profitability and liquidity.

SCOPE OF THE STUDY

The scope of study is to find the financial performance of the MARUTI SUZUKI MOTORS. For the preparation of ratio analysis and working capital statement past five years balance sheet (2015 to 2019) has taken for study. This study is made mainly to know the profitability, liquidity and financial growth of the company. These suggestions would help the company for further improvements.

OBJECTIVES OF THE STUDY

1. To analyze profitability position of the Maruti Suzuki Motors.
2. To know the liquidity position of the company.
3. To know the changes over working capital for the period of four years (2015-19).



RESEARCH METHODOLOGY

Secondary data was mainly used for the study. The data used in this study is mainly from the audited annual reports of the company. The present study covers the period of five years from 2014-2015 to 2018-2019.

Tools and Techniques

The ratios are used as a tool for analyzing the financial performance on Maruti Suzuki Motors. Ratios are calculated from previous year and current year. The tools are

1. Ratio analysis.
 - Profitability ratio
 - Liquidity ratio
2. Working capital.

LIMITATIONS OF THE STUDY

- The period of the study limited only to five years.
- The end result of the study is relevant best for Maruti Suzuki Limited and it cannot use in another company.
- The data are secondary by nature and any bias in them reflects in the analysis and the conclusion of the study.

REVIEW OF LITERATURE

Mr. V. Elayabharathi, Mrs. D. Praveena, Mrs. S. Rathika (2019), “a study on financial performance analysis with reference to TNSC Bank, Chennai”. They analyzed the financial performance of the TNSC APEX CO-OPERATIVE BANK. They suggested the bank needs to maintain proper receivables. The performance should be continued and improvement to be made in order to attain the objectives of the concern which pave the way to have the result in attaining the competitive advantage.

Lam Weng Hoe, Lam Weng Siew, Liew Kah Fai (2019), “a study on performance analysis on Telecommunication companies in Malaysia with TOPSIS model”. The objective of this paper is to propose a conceptual framework to evaluate, compare and rank the financial performance of companies in Malaysia. They concluded that the best ideal and worst ideal solutions for each financial ratio can serve as the benchmark to the telecommunication companies for further improvement.

Dr. D. Pathma Priya (2019), “a study on financial performance analysis of HDFC limited”. The study was made to analyze the financial performance of HDFC limited for the period of five years and to offer suggestions based on their findings of the study. She concluded that the financial performance of the HDFC Limited is at satisfactory level and suggested to concentrate to get back the funds from debt to equity funds and also reduce and long term financial obligations

DATA ANALYSIS AND INTERPRETATION PROFITABILITY RATIO

Efficiency of a business is measured by profitability. It measures the profit earning capacity of the business concern. The important profitability ratios are discussed below:

1. Gross profit ratio
2. Net profit ratio
3. Operating profit ratio
4. Operating ratio

1. Gross Profit Ratio

This ratio indicates the efficiency of trading activities. The relationship of gross profit to sales is known as gross profit ratio. It is also known as gross margin or trading margin ratio. The ratio is calculated as:

$$\text{Gross Profit Ratio} = \text{Gross Profit} / \text{Sales} \times 100$$

Table No. 1
Table Showing Gross Profit Ratio

Year	Gross Profit	Sales	Ratio
2014-2015	7338.50	49970.60	14.68
2015-2016	10263.90	57538.10	17.83
2016-2017	12562.40	68034.80	18.46
2017-2018	13761.30	79762.70	17.25
2018-2019	13484.50	86020.30	15.67

(Source: 5 years annual report of Maruti Suzuki)

INTERPRETATION

The above table 1 shows the relationship between the gross profit and net sales in the

percentage. During the study period 2014-2015 the gross profit ratio is 14.68. On 2015-2016 the ratio increased to 17.83 and further it moves upward to



18.46 in 2016-2017. During 2017-2018 it decreased to 17.25. In the year 2018-2019 it decreased to 15.67. The average gross profit position was 16.7%. However the company maintains a good gross profit ratio.

This ratio determines the overall efficiency of the business. The relationship of net profit to sales is known as net profit ratio. It is determined by dividing the net income after tax to the net sales for the period and measure the profit per rupee of sales. The ratio is calculated as:

2. Net Profit Ratio

$$\text{Net Profit Ratio} = \text{Net Profit} / \text{Sales} \times 100$$

Table No. 2
Table Showing Net Profit Ratio

Year	Net Profit	Sales	Ratio
2014-2015	3243.37	49970.60	6.49
2015-2016	4525.46	57538.10	7.86
2016-2017	5754.21	68034.80	8.45
2017-2018	6400.85	79762.70	8.02
2018-2019	5831.25	86020.30	6.77

(Source: 5 years annual report of Maruti Suzuki)

INTERPRETATION

The above table 2 shows the relationship between the net profit and net sales in percentage. During the study period 2014-2015 the ratio was 6.49 then it moves upward to 7.86 and 8.45 in the year 2015-2016 and 2016-2017 respectively. The ratio decreased to 8.02 in 2017-2018 and it also moves downward to 6.77 in the year 2018-2019. The

average net profit position was 7.5% and is in decreasing trend.

3. OPERATING PROFIT RATIO

This ratio is an indicator of the operational efficiency of the management. It establishes the relationship between operating profit and sales. The ratio is calculated as:

$$\text{Operating Profit Ratio} = \text{Operating Profit} / \text{Sales} \times 100$$

Table No. 3
Table Showing Operating Profit Ratio

Year	Operating Profit	Sales	Ratio
2014-2015	7544.50	49970.60	15.09
2015-2016	10345.40	57538.10	17.98
2016-2017	12651.80	68034.80	18.59
2017-2018	14107.00	79762.70	17.68
2018-2019	13560.30	86020.30	15.76

(Source: 5 years annual report of Maruti Suzuki)

INTERPRETATION

The above table 3 shows that the operating profit ratio is 15.09 in year 2014-15 and keeps fluctuating for upcoming years. But in 2017-2018 it goes

downward to 17.68 and further it decreased to 15.76 in the year 2018-2019. So the company should decrease their expense to increase their profit.

4. OPERATING RATIO

This ratio determines the operating efficiency of the business concern. Operating ratio measures the amount of expenditure incurred in

production, sales and distribution of output. The relationship between operating cost to sales is known as operating ratio the ratio calculated as:



$$\text{Operating Ratio} = \text{Cost of Goods Sold} + \text{Operating Expenses} / \text{Sales} \times 100$$

Table No. 4
Table Showing Operating Ratio

(Rupees in Cores)

Year	Operating Profit Ratio	Ratio
2014-2015	15.09	84.91
2015-2016	17.98	82.02
2016-2017	18.59	81.41
2017-2018	17.68	82.32
2018-2019	15.76	84.24

(Source: 5 years annual report of Maruti Suzuki)

INTERPRETATION

From the above table 4 shows that operating profit for the year 2014-2015 was 84.91 and it is decreased to 82.02 in 2015-2016. Again the ratio decreased to 81.41 in 2016-2017. On 2017-2018 the ratio is increased to 82.32 and it moves upward to 84.24 in 2018-2019. It is clear that operating profit of Maruti Suzuki motors consistently good in all the years.

LIQUIDITY RATIO

Liquidity ratio measure the firm's ability to pay off current dues i.e., repayable within a year.

Liquidity ratios are otherwise called as short term solvency ratios. The important liquidity ratios are

1. Current Ratio
2. Liquid Ratio
3. Absolute Liquid Ratio

1. CURRENT RATIO

This ratio is used to assess the firm's ability to meet its current liabilities. The relationship of current assets to current liabilities is known as current ratio. The ratio is calculated as:

$$\text{Current Ratio} = \text{Current Asset} / \text{Current Liabilities}$$

Table No. 5
Table Showing Current Ratio

(Rupees in Cores)

Year	Current Asset	Current Liabilities	Ratio
2014-2015	5199.80	8450.50	0.61
2015-2016	6789.20	10808.30	0.62
2016-2017	6597.40	12742.80	0.51
2017-2018	6704.10	15331.30	0.43
2018-2019	7316.10	14000.70	0.52

(Source: 5 years annual report of Maruti Suzuki)

INTERPRETATION

The above table 5 shows that the current ratio in the year 2014-15 was 0.61 and then it is moves upward to 0.62 in the year 2015-16, next year onwards it move downward to 0.51 in the year 2016-17 and it again moves downwards to 0.43 in 2017-2018 and finally in the year 2018-19 it went downwards to 0.52. The normal current ratio is 2:1. The above table shows current ratio lower than 2% in

all financial year. This shows that the company is not enjoying credit worthiness.

2. LIQUID RATIO

This ratio is used to assess the firm's short term liquidity. The relationship of liquid assets to current liabilities is known as liquid ratio. It is otherwise called as quick ratio or acid test ratio. The ratio is calculated as:



$$\text{Liquid Ratio} = \text{Liquid Assets} / \text{Current Liabilities}$$

Table No. 6
Table Showing Liquid Ratio

Year	Liquid Asset	Current Liabilities	Ratio
2014-2015	2513.9	8450.50	0.29
2015-2016	3657.1	10808.30	0.33
2016-2017	3335.2	12742.80	0.26
2017-2018	3543.3	15331.30	0.23
2018-2019	3990.4	14000.70	0.28

(Source: 5 years annual report of Maruti Suzuki)

INTERPRETATION

The above table 6 shows that the liquid ratio in 2014-2015 was 0.29 then it increased to 0.33 in 2015-2016. In the year 2016-2017 the ratio was decreased to 0.26 in 2016-2017 and it is further decreased to 0.23 in 2017-2018. In the year 2018-2019 the ratio is 0.28. The company is not having adequate cash to meet its expenses.

3. ABSOLUTE LIQUID RATIO

It is a modified form of liquid ratio. The relationship of absolute liquid assets to liquid liabilities is known as absolute liquid ratio. This ratio is also called as super quick ratio. The ratio is calculated as:

$$\text{Absolute Liquid Ratio} = \text{Absolute Liquid Assets} / \text{Liquid Liabilities}$$

Table No. 7
Table Showing Absolute Liquid Ratio

Year	Absolute Liquid Profit	Current Liabilities	Ratio
2014-2015	18.30	8450.50	2.16
2015-2016	39.10	10808.30	3.61
2016-2017	13.80	12742.80	1.08
2017-2018	71.10	15331.30	4.63
2018-2019	178.90	14000.70	0.01

(Source: 5 years annual report of Maruti Suzuki)

INTERPRETATION

In the above table 7 shows the absolute liquid ratio in 2014-2015 was 2.16 and it moves upward to 3.61 in 2015-2016. The ratio was decreased to 1.08 in 2016-2017 then it increased gradually to 4.63 in 2017-2018. The ratio in the year 2018-2019 is 0.01 which was least. The ratio is below 1 in 2018-2019 and hence the company needs more than its cash reserve to pay-off its current debt.

WORKING CAPITAL

Working capital is a financial metric which represents operating liquidity available to a business, organization, or other entity, including governmental entities. Along with fixed assets such as plant and equipment, working capital is considered a part of operating capital. Working capital is a financial measure which calculates whether a company has enough liquid assets to pay its bills that will be due in a year. Working capital can be calculated by deducting the current liabilities from the current assets.



Working Capital = Current Assets – Current Liabilities

Table No. 8

Table Showing The Schedule Of Changes In Working Capital For The Year Ended 2015-2016

(Rs. in Crores)

PARTICULARS	2015	2016	INCREASE	DECREASE
Current Assets				
Inventories	2685.90	3132.10	446.2	
Sundry Debtors	1069.80	1322.20	252.4	
Cash and Bank	18.30	39.10	20.8	
Loans and Advances	1425.80	2295.80	870	
Total (A)	5199.80	6789.20		
Current Liabilities				
Current liabilities	7090.10	9613.80		2523.7
Provisions	1360.40	1194.50	165.9	
Total (B)	8450.50	10808.30		
Working capital (A-B)	-3250.7	-4019.1		
Net decrease in working capital		768.4	768.4	
Total	-3250.7	-3250.7	2523.7	2523.7

(Source: Secondary Data)

INTERPRETATION

Current asset during 2015, 2016 is Rs. 5199.80 and Rs. 6789.20 respectively. The current asset increases to Rs. 1589.4. A current liability during 2015, 2016 is Rs. 8450.50 and Rs.10808.30

respectively. The current liability increases to Rs. 2357.8.

INFERENCE

Net decrease in working capital is Rs. 768.4

Table No. 9

Table Showing The Schedule Of Changes In Working Capital For The Year Ended 2016-2017

(Rs. in Crores)

PARTICULARS	2016	2017	INCREASE	DECREASE
Current Assets				
Inventories	3132.10	3262.20	130.1	
Sundry Debtors	1322.20	1199.20		123
Cash and Bank	39.10	13.80		25.3
Loans and Advances	2295.80	2122.20		173.6
Total (A)	6789.20	6597.40		
Current Liabilities				
Current liabilities	9613.80	11495.10		1881.3
Provisions	1194.50	1247.70		53.2
Total (B)	10808.30	12742.80		
Working capital (A-B)	-4019.1	-6145.40		
Net decrease in working capital		2126.3	2126.3	
Total	-4019.1	-4019.1	2256.4	2256.4

(Source: Secondary Data)

INTERPRETATION

Current asset during 2016, 2017 is Rs. 6789.20 and Rs. 6597.40 respectively. The current asset decreases to Rs. 191.8. A current liability during 2016, 2017 is Rs.10808.30 and 12742.80

respectively. The current liability increases to Rs. 1934.5.

INFERENCE

Net decrease in working capital is Rs. 2126.3.



Table No. 10
Table Showing The Schedule Of Changes In Working Capital For The Year Ended 2017-2018
(Rs. in Crores)

PARTICULARS	2017	2018	INCREASE	DECREASE
Current Assets				
Inventories	3262.20	3160.80		101.4
Sundry Debtors	1199.20	1461.80	262.6	
Cash and Bank	13.80	71.10	57.3	
Loans and Advances	2122.20	2010.40		111.8
Total (A)	6597.40	6704.10		
Current Liabilities				
Current liabilities	11495.10	13917.20		2422.1
Provisions	1247.70	1414.10		166.4
Total (B)	12742.80	15331.30		
Working capital (A-B)	-6145.40	-8627.20		
Net decrease in working capital		2481.80	2481.8	
Total	-6145.40	-6145.40	2801.7	2801.7

*(Source: Secondary Data)***INTERPRETATION**

Current asset during 2017, 2018 is Rs. 6597.40 and Rs. 6704.10 respectively. The current asset increases to Rs. 106.7. A current liability during 2017, 2018 is Rs. 12742.80 and Rs. 15331.30

respectively. The current liability increases to Rs. 2588.5

INFERENCE

Net decrease in working capital is Rs. 2481.80.

Table No. 11
Table Showing The Schedule Of Changes In Working Capital For The Year Ended 2018-2019
(Rs. in Crores)

PARTICULARS	2018	2019	INCREASE	DECREASE
Current Assets				
Inventories	3160.80	3325.70	164.9	
Sundry Debtors	1461.80	2310.40	848.6	
Cash and Bank	71.10	178.90	107.8	
Loans and Advances	2010.40	1501.10		509.3
Total (A)	6704.10	7316.10		
Current Liabilities				
Current liabilities	13917.20	12703.40	1213.8	
Provisions	1414.10	1297.30	116.8	
Total (B)	15331.30	14000.70		
Working capital (A-B)	-8627.2	-6684.60		
Net increase in working capital		1942.6		1942.6
Total	-8627.2	-8627.2	2451.9	2451.9

*(Source: Secondary Data)***INTERPRETATION**

Current asset during 2018, 2019 is Rs. 6704.10 and Rs. 7316.10 respectively. The current asset increases to Rs. 612. A current liability during 2018, 2019 is Rs. 15331.30 and Rs. 14000.70 respectively. The current liability decreases to Rs. 1330.6.

INFERENCE

Net increase in working capital is Rs. 1942.6.

FINDINGS, SUGGESTION AND CONCLUSION**FINDINGS**

- Gross profit of the company was highest in the year 2016-2017 and lowest in the year 2014-2015.
- Net profit of the company was highest in the year 2016-2017 and lowest in the year 2014-2015.



- Operating profit ratio of the company was highest in the year 2016-2017 and lowest in the year 2018-2019.
- Operating Ratio of Maruthi Suzuki Motors is maximum during the year 2014-2015 and lowest in the year 2018-2019.
- Current ratio of the company was highest in the year 2015-2016 and lowest in the year 2017-2018.
- Quick ratio, highest in the year 2015-2016 and in the lowest in the year 2017-2018.
- Absolute liquid ratio of the company was highest in the year 2017-2018 and lowest in the year 2018-2019.
- Working capital was decreased in the year 2015 and 2016.
- Working capital was decreased in the year 2016 and 2017.
- Working capital was decreased in the year 2017 and 2018.
- Working capital was increased in the year 2018 and 2019.

REFERENCE

1. Mr. V. Elayabharathi, Mrs. D. Praveena, Mrs. S. Rathika (2019), "A study on financial performance analysis with reference to TNSC bank, Chennai", Vol-5 Issue-2 2019, IJARIE-ISSN(0)-2395-4396, pp: 2949-2955.
2. Lam Weng Hoe, Lam Weng Siew, Liew Kah Fai (2019), "Performance analysis on telecommunication companies in Malaysia with TOPSIS model", Indonesian journal of electrical engineering and computer science, February 2019, Volume 13, No.2, ISSN: 2502-4752, pp: 744-751.
3. Dr. D. Pathma priya (2019), "A study on financial performance analysis of HDFC limited", the research journal of social sciences, April 2019, Volume 10 No.4, ISSN 0025-1348, pp: 301-311.

SUGGESTIONS

- The company can improve its profitability position by pay off current liabilities.
- In order to improve the stable financial position of the company current liability can be reduced by selling of unnecessary assets.
- Net profit of the company can be increased by reducing operational expenses.
- The company's profits are huge in the current year, it is better to declare dividend to shareholders.
- The working capital of the company in the year 2018-2019 was increased it has to maintain the position to increase more profit by managing debtors effectively.

CONCLUSION

The study undertaken with objective of profitability of Maruti Suzuki motors. Even though the profitability condition in the satisfactory level, in upcoming years the firm should focus on getting of more profits by considering internal as well as external factors. There is a fluctuation in the liquidity position of the company so they have to invest more amount in current assets in order to improve their liquidity position hence, if the given suggestion are implement then the overall efficiency and profitability of Maruti Suzuki can be improved. The working capital of the company can be increased by managing debtors effectively.



A STUDY ON CUSTOMER SATISFACTION TOWARDS FLIPKART SERVICES

Mr.A.David

*Associate Professor, Department of Commerce with Professional Accounting,
Dr. N.G.P. Arts and Science College, Coimbatore*

T.P.Prabin

*171pa146 B.Com.(PA), Department of Commerce with Professional Accounting,
Dr.N.G.P Arts and Science College, Coimbatore*

ABSTRACT

Online media promoting has become the most impressive mode for organizations looking to reach out to their possibilities and clients. Given the wide reach of SMM, firms are progressively depending on it, In request to accomplish their advertising and marking goals .By supplanting the customary methods of promoting, online media has given new occasions to firms to lock in shoppers in social cooperation on the web. The goal of the current examination is to explore the capability of web-based media promoting as a successful showcasing apparatus that makes a difference them to influence impression of clients and eventually impact their buy choices. The study expects to feature the preferences that organizations gain by successful utilization of SMM

INTRODUCTION

Internet is changing the way consumers shop and buy goods and services and has rapidly evolved into a global phenomenon. Many companies have started using the Internet with the aim of cutting marketing costs, thereby reducing the price of their products and services in order to stay ahead in highly competitive markets.

Companies also use the Internet to convey, communicate and The information, to sell the product, to take feedback and also to conduct satisfaction surveys with customers. Customers use the Internet not only to buy the product online, but also to compare prices, product features and after sale service facilities they will receive if they purchase the product from a particular store.

STATEMENT OF THE PROBLEM

To enhance and attract online customer it is very important to know about their behavior and understand what they require and need. Since online shopping is the new medium of shopping with new demands of consumers. All customers have their own desires and demands for products so that it is very crucial for all online retailers to identify and know about their online consumers.

SCOPE OF STUDY

This study will helpful in knowing the factors responsible for gaining customer satisfaction towards Flipkart in Coimbatore city.It focuses on the opinion of the respondents regarding Flipkart.This research will also helpful in understanding the customer satisfaction of the different people in Indian society especially Coimbatore city towards Flipkart.



OBJECTIVE OF STUDY

- To analyse the socio demographic datas with the personal factors.
- To study about the marketing strategies of social media marketing in current generation.
- To study and demonstrate the links between social media marketing efforts and their consequences.
- To study about the positive impact on the respondents of perception on online advertisements.
- To know about the acceptance of social media advertisement and marketing strategies among youths.

STATISTICAL TOOL USED

1. Simple Percentage Analysis
2. Rank Analysis
3. T- test Analysis

LIMITATION OF STUDY

- The sample units are confined to only Coimbatore city.
- The study is done without any mediating variable that can alter the relationship.
- Time of the study was limited only 6 months.
- The number of the respondents was limited to 120 only.

REVIEW OF LITERATURE

Rangaswamy(2005) in their research shows that the internet has become a useful tool for comparison shopping and users often click around various sites to view and compare products, proceed to leave the site altogether, and then, possibly, return days later to purchase a product, or they might buy locally.

Yadav (2012)¹ has made an attempt to set up the significance of social networks as an advertising medium and evaluated the existing advertising methods that are in trend via certain case studies and concluded that social websites are not just a tool to interact with the different people but also medium to reach the prospective customers. Akrimi and Khemakhem (2012)² argued that social websites play a very

important role to influence the buyers. Facebook has more than a billion users since its beginning in 2004. Social networks have strongly changed the spread of information by making it really easy to share (Akrimi and Khemakhem, 2012). As high-profile people are connected to Facebook, it is measured that if businesses are not available on Facebook, then it has no existence in the online world. Facebook has become an essential part to communicate strategies and facilitate marketing activities. It acts as an essential channel to position firms and its brands in the market (Khan & Khan, 2012).

DATA ANALYSIS AND INTERPRETATION

The data collected from the samples have systematically applied and presented in the tables under various headings in the following pages. They were also arranged in such a way that, a detailed analysis can; be made so as to present suitable interpretation for the same. The data have been analyzed using the following statistical tools.

- Simple percentage analysis
- Rank analysis
- T- test Analysis

SIMPLE PERCENTAGE ANALYSIS

The percentage analysis is mainly employed to find the distribution of different categories of respondents. As the value are expressed in percentage it facilitates comparison and standardization. The analysis describes the classification of the respondents failing under each category.

FORMULA PERCENTAGE=

$$\frac{\text{Number of respondents}}{\text{Total number of respondents}} * 100$$



TABLE NO: 1
Earning members in a family

S. No.	Earning members in a family	No. of respondents	Percentage
1.	One member	39	30%
2.	2-4 members	43	33.07%
3.	5-7 members	38	29.23%
4.	Above 7 members	10	7.69%
	Total	200	100 %

Source: Primary Data

Earning income in a family

■ One member ■ 2-4 members
■ 5-7 members ■ Above 7 members

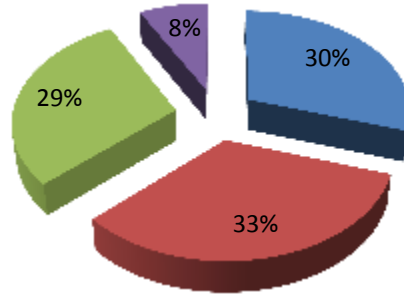

INTERPRETATION

The above table shows that 30 % of the respondents family has one earning member, 33.07 % of the respondents family has 2-4 earning members, 29.23% of the respondent family has 5-7 earning members and 7.69 % of the respondents family has above 7 members.

INFERENCE

It is inferred that majority (33.7 %) of the respondents family members has 2-4 earning members.

TABLE NO:2
ACCOUNT TYPE AND PRIVACY

S. No	Account type and privacy	No. of respondents	Percentage
1.	Private/only friends	82	63.07%
2.	Public/everyone	48	36.93%
	Total	130	100 %

Source: Primary Data

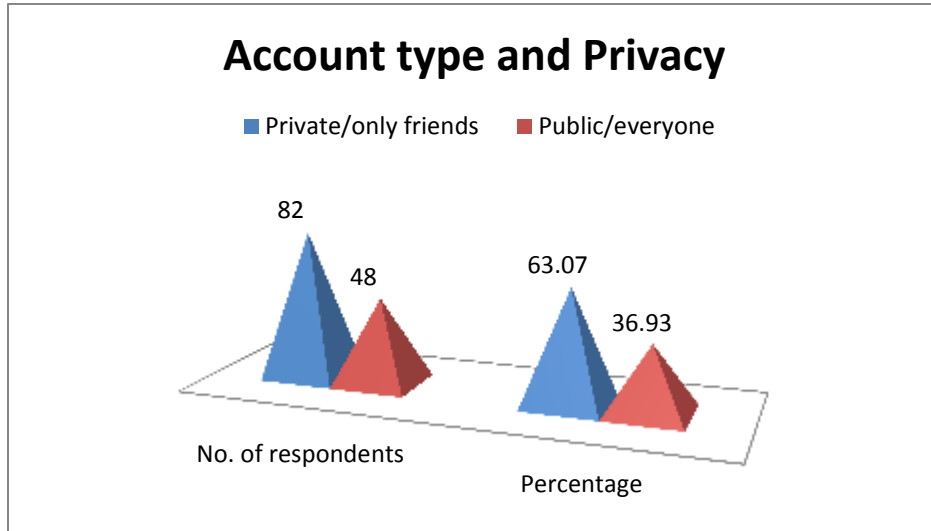

INTERPRETATION

The above table shows that 63.07 % of the respondents are having private/friends only account type and 36.93% of the respondents are having a public/everyone account type.

INFERENCE

It is inferred that most (63.07 %) of the respondents are having private/friends only account type.

RANK ANALYSIS

A Rank analysis is any of several statistics that measure an ordinal association. The relationship between ranking of different ordinal variables or different ranking of the same variable. Where a “ranking” is the assignment of the label “first”, “second”, “third”, etc. to different observations of a particular variable. A rank analysis measures the degree of similarity between two rankings, and can be used to assess the significance of the relation between them.

TABLE NO: 3

S.NO.	FACTOR	1	2	3	4	5	TOTAL	RANK
1	High quality	8(5) 40	12(4) 60	18(3) 90	9(2) 45	17(1) 17	320	3
2	slogan	6(5) 30	12(4) 60	13(3) 65	24(2) 120	10(1) 10	325	2
3	Precise information	6(5) 30	16(4) 80	18(3) 90	13(2) 65	13(1) 13	335	1
4	Brand image	20(5) 100	12(4) 60	7(3) 35	9(2) 45	15(1) 15	240	5
5	High quality audio/video	27(5) 135	11(4) 55	7(3) 35	10(2) 50	8(1) 8	315	4

Source: primary data



INTERPRETATION

Among the various factors listed above the respondents have their own preferences towards different factors, which they feel as important. The respondents felt that precise information is the important facility, so this factor is most important thus it ranks number 1.

Apart from precise information the respondents prefer slogan factor is important thus it ranks number 2.

Nowadays peoples prefer high quality, thus it ranks number 3, apart from these the respondents also prefer high quality audio/ video and it ranks number 4. Apart from these the respondents prefer brand image and it ranks number 5.

INFERENCE

It is lucid that precise information was given the first rank; slogan factor were given the second rank and high quality having third rank, fourth rank was given to the high quality audio/video and finally, the fifth rank was given to brand image

FINDINGS, SUGGESTIONS AND CONCLUSION

FINDINGS

PERCENTAGE METHOD

1. Majority (50.7%) of the respondents are male.
2. Majority (50.7%) of the respondents are in Ages of (21-30).
3. Majority (59.3%) of the respondents are from college level.
4. Majority (85%) of people are unmarried.
5. Majority (85.7%) of the respondents are in urban locality.
6. Majority (52.1%) of the respondents have 1 no of earning person in their family.
7. Mostly (47.1%) of the respondents shop online more than 1 month.
8. Mostly (47.1%) of the respondents know through advertisement.
9. Majority (93.6%) of the respondents said that the rates are reasonable.
10. Majority (73.6%) of the respondents told that the quality of the product is good.
11. Mostly (49.3%) of the respondents like the electronics.
12. Mostly (43.6%) of the respondents of the respondents like customer service.
13. Majority (83.6%) of the respondents are not satisfied with delivery charges.
14. Majority (90.7%) of the respondents use cash on delivery.

15. Majority 87.9% of the respondents did not faced any problem while doing online shopping in Flipkart.

16. Majority 87.1% of the respondents have used at least once. CENTAE ANALYSIS

SUGGESTIONS

- This study suggests that the social media influencer should concentrate under the age group of above 35 years.
- Most of the respondents are witnessing social media advertisement for the Brand Image.
- Most of the respondents says social media advertisements are sometimes eye catchy, if it were more attractive, they would use more promptly.
- Most of the respondents feels that they exit from videos as they mistakenly clicked on it, so videos should be informative.
- The social media should concentrate more in privacy factor concept. A non-aggressive in privacy factor lead to misruption in respondents view.

CONCLUSION

The study concludes that the users are preferring social media especially Whatsapp and Instagram. From the survey younger generation and middle age are more interested in social media, the buying behavior is governed predominantly by the need of power and respect for the iconic brand and users are mostly employed females, 19-25 years of age, including some students. Most of the customers are attracted to the new release of updations, users are addicted to the social media platforms. Most of them prefer to use social media to connect with people. Most of the users recommend social media marketing to others.

REFERENCE

1. *Bashar, A., Ahmad, I., & Wasiaq, M. (2012). Effectiveness Of Social Media As A Marketing Tool: An Empirical Study, International Journal Of Marketing, Financial Services & Management Research, 1(11), 88-99.*
2. *¹Yadav, N. (2012). Social Networking Sites-A New Vechicle for Advertising. MIMT Journal of IT & Management Research , 2 (1), 38-48.*
3. *¹Akrimi, Y., & Khemakhem, R. (2012). What Drive Consumers to Spread the Word in Social Media? Journal of Marketing Research & Case Studies, 2012, 1-14. <http://dx.doi.org/10.5171/2012.969979>*



THE EFFECT OF CLIMATE CONDITIONS IN UZBEKISTAN ON BIOLOGICAL INDICATORS OF CHINESE SILKWORM BREEDS AND HYBRIDS

Oripov Otabek Oripovich

*Independent researcher, Department of the Sericulture and Mulberry Growing,
Tashkent State Agrarian University, Tashkent, Uzbekistan*

Umarov Shavkat Ramazanovich

*Doctor of Agricultural Sciences, Professor of the Department Sericulture and Mulberry Growing,
Tashkent State Agrarian University, Tashkent, Uzbekistan*

Article DOI: <https://doi.org/10.36713/epra5764>

ABSTRACT

The article presents thorough analysis results and scientifically proven theoretical data on hatching and care of eggs of imported mulberry silkworm breeds and hybrids at different temperatures and humidity. The aim is to produce silkworm eggs based on the adaptation of imported mulberry silkworms to the rapidly changing natural climate condition of Uzbekistan, to improve the productivity and technological properties of cocoons. Effective scientific solutions for the care of imported eggs have been determined by substantiating effective agrotechnology for silkworm rearing and defining the effect of temperature and relative air humidity at cocoonery and feed amount on biological, cocoon productivity and technological properties of silkworms in the rearing of mulberry silkworm breeds and hybrids imported from abroad, adapted to the conditions of Uzbekistan.

KEYWORDS: *silkworm eggs, incubation, temperature, humidity, light, mulberry leaves, silkworm, breed, hybrid, cocoonery, truss, pupa, moth, pure cocoon, silk.*

INTRODUCTION

Today, the demand in the world market for cocoon, natural silk and silk fabrics is growing day by day. At present, "...mulberry silkworm eggs are produced in more than 20 countries with developed silk production, and 14.5 million box of silkworm eggs are produced in People's Republic of China, 5.0 million box in India, 300000 boxes in Uzbekistan and the remaining 3.2 million box corresponds to the share of other countries". Uzbekistan is the third largest cocoon producer in the world, achieving an average of 59.0 kg of cocoons per box of silkworm eggs. The geographical location of Uzbekistan is currently a favorable ecological zone for the cultivation of silkworm, and more than 380-400 thousand boxes of silkworms are annually reared [8, 9].

Researches are being carried out around the world to create breeds and hybrids of mulberry silkworms suitable for different regions and to develop and introduce new innovative agro-technologies in silkworm breeding. In this regard, given the global climate change, the creation of breeds and hybrids of mulberry silkworm adapted to rapidly changing and optimal climatic conditions, the development of new intensive technologies for silkworm rearing and the introduction of foreign breeds and hybrids are of great scientific and practical importance [5, 6].

Extensive scientific research on the assessment of the impact of the external environment on the important traits and characteristics of mulberry silkworm in our country, the effect of feed amount, quality, air temperature and relative humidity on the growth and



development of silkworm and the manifestation of hereditary potential of different breeds and hybrids at different conditions were conducted by U.N. Nasirillaev, N.A. Akhmedov, Sh.R. Umarov, S.S. Lezhenko and B.U. Nasirillaev [4, 5, 6].

Moreover, scientists from the advanced countries with developed cocoon production, A.Z. Zlotin, V.N. Kirichenko, O.Zh. Zhurovl, M.E. Braslavsky, N.A. Begum, M. Rekha, N. Baramidze carried out research work and achieved positive results on the study of resistance of mulberry silkworm to adverse conditions during embryonic development, creation of new breeds using voltinism, as well as, compensation for the harmful effects of adverse conditions through the use of biologically active substances.

Sufficient attention has not been paid yet to scientific research on the creation of specific care and rearing agro-technologies of silkworm focused on the adaptation of imported mulberry silkworm breeds to the conditions of the Republic, production of high-quality pure cocoons, preparation of high-quality silkworm eggs, as well as increasing cocoon productivity and technological properties. Carrying out research work to solve these problems is of great scientific and practical importance [7, 8, 9].

However, certain results are being achieved in the creation of local breeds and hybrids adapted to the specific climatic conditions of the republic. But, as mentioned above, insufficient attention has been paid to the development and scientific substantiation of optimal care agro-technologies aimed at adapting imported mulberry silkworm breeds to the conditions of Uzbekistan, increasing the yield, varietal potential and technological properties of cocoons.

In the decree "About Actions Strategy for development of the Republic of Uzbekistan in 2017-2021", Presidential decree of the Republic of Uzbekistan from March 29, 2017 "About the measures on the establishment of the activity of "Uzbekipaksanoat" association" numbered-2856 and Presidential decree "About additional measures on further development of sericulture sector" dated March 20, 2018 йил numbered-3616, the tasks on extensive testing of selection achievements, developing primary seed breeding of silkworm breeds and hybrids, creation of breeds and hybrids suitable to international requirements through developing advanced scientific elaborations and intensive agro-technologies considering natural climatic conditions of regions, increasing the potential of production of local silkworm and cocoon, as well as export potential of sericulture industry by improving the quality [1, 2, 3].

MATERIALS AND METHODS

Experiments on the substantiation of optimal technology for caring and rearing of silkworm (*Bombyx mori* L.) breeds and hybrids imported from People's Republic of China were conducted in 2013-2018.

Experimental testing on two productive silkworm breeds "Khitoy" and "Yaponiya" imported from China, was performed in the laboratory of "Sericulture and mulberry growing" department of Tashkent state agrarian university, in "Ipak Kurti Urugchiligi" LLC in Okkurgan district of Tashkent region, in "Ipak Kurti Urugchiligi" LLC in Karmana district of Navoi region and another testing experiment was conducted on "Jingsong × Haoyue" and "Haoyue × Jingsong" hybrids imported from People's Republic of China in "Nurli Tong Silk" LLC in Margilan town of Fergana region.

In all research, observations and experiments on the substantiation of the technology of optimal care and rearing of foreign breeds and hybrids of mulberry silkworms, the geographical location of the region, including the mountain and desert zones, and their natural soil-climatic conditions were taken into account.

The selection of regions with different climatic conditions of the republic has made dissertation research more effective and reliable.

Since 70-80% of silkworm eggs raised in our country are imported from abroad, mainly from the People's Republic of China, foreign industrial hybrids "Jingsong × Haoyue" and "Haoyue × Jingsong" were used in our research.

Local silkworm breeds "Asaka" and "Marhamat" as well as hybrids "Ipakchi-1 x Ipakchi-2" that are widely used in the Republic (60-70%) presently, were used as a comparator.

Mulberry leaves grown on university campus and small experimental farms, as well as in the areas with different soil-climatic conditions, were used as food for silkworms.

In the first part of our experiments, 20 egg batches were taken from each of the eggs laid by female moths of "Khitoy" and "Yaponiya" breeds imported from China and they were left for hatching. Depending on the hatching of caterpillars from the egg batches, 5 variants were prepared from each of the experimental "Khitoy" and "Yaponiya" breeds.

"Asaka" breed zoned in the Republic was chosen as a comparative control for the experimental "Khitoy" breed imported from China. "Markhamat" breed zoned in the Republic was used as a comparative control for "Yaponiya" breed.

In the second part of our experiments, 15 variants from "Jingsong × Haoyue" and "Haoyue × Jingsong" hybrids imported from People's Republic of China were made and observed.

Ipakchi-1 × Ipakchi-2 hybrids zoned in the republic and reared extensively on the farms, were taken as control and comparator for the silkworm hybrids imported from abroad.

Eggs of imported silkworm breeds and hybrids hatched and caterpillars were reared, as well as the moths come out of cocoon mated in the variants at three different temperatures and humidity:



- in the first experimental testing, temperature was 20-21°C, humidity 60-65 %;
- in the second experimental testing, temperature was 26-27°C, humidity 75-80 %;
- in the third experimental testing, temperature was 28-29°C, humidity 70-75 %.

The following breeds and hybrids were used by variants:

Variant 1 – “Yaponiya” breed eggs imported from China.

Variant 2 – “Khitoy” breed eggs imported from China.

Variant 3 - “Jigsong × Haoyue” hybrid eggs imported from China.

Variant 4 - “Haoyue × Jigsong” hybrid eggs imported from China.

Variant 5 - (comparative) Ipakchi-1 × Ipakchi-2 hybrid eggs made in Uzbekistan.

RESULTS AND DISCUSSION

The scientific significance of the research results is explained by the fact that the data were theoretically obtained and generalized on scientific substantiation of interdependence of changes in biological attributes (egg hatching, caterpillar survival, larva period, skin peeling, cocoon spinning and etc.), cocoon productivity (cocoon yield and quality, silkiness) and technological attributes (raw silk yield, unwinding cocoon and its metric number), as well as fertility of moths (laying a lot of eggs) on food, environmental and rearing conditions.

On the basis of the research results conducted to substantiate optimal care and rearing technology for imported silkworm (*Bombyx mori* L.) breeds and hybrids:

Recommendation named "Agrotechnologies for the care for imported silkworm breeds and hybrids in Uzbekistan" has been developed and approved on improving the quality of hybrid eggs produced by imported breeds in the Republic's egg-producing enterprises and cocoon quality of silkworms reared on the farms (Reference of Agriculture Ministry from June 17, 2020 numbered 02/028-1748). As a result, 4.8 grams of additional eggs were produced from one box of 25 boxes of imported pure silkworms, the economic efficiency of one box was 55404.0 soums and the net profit was 21554.0 soums, the profitability increased by 12.7%;

“Yaponiya” silkworm breed imported from China was reared in “Ipak Qurti Urugchiligi” LLC in Karmana district of Navoi region in 21 boxes, one box of imported pure silkworm produced 5,1 grams of additional silkworm eggs, from which economic efficiency made 55606.8 soums, net profit was 22952.3 soums and profitability increased by 14.1 %;

Rearing of “Jigsong × Haoyue” industrial hybrid eggs of 21 boxes of imported silkworm from People’s Republic of China was implemented “Nurli Tong Silk”

LLC in Fergana region (Reference of Agriculture Ministry from June 17, 2020 numbered 02/028-1748). In result, one box of introduced hybrid produced 0.89 grams of additional raw silk, while 21 boxes of imported hybrid yielded 18,7 kgs of raw silk after proper care, its economic efficiency made 6025656 soums, profitability increased by 27,6 %.

It is known that in recent years, 70-80% of mulberry silkworm eggs are imported from abroad for the production of 18-20 thousand tons of raw cocoons in the country. However, the average cocoon yield obtained by rearing the caterpillars hatched from these eggs, is no more than 55-57 kg. In order to find out the reason for this, imported and local silkworm breeds and hybrids were selected and accordingly variants were prepared from their eggs. It has been planned to produce abundant best quality yield and to improve technological indicators of cocoon by incubating imported silkworm eggs, caring for hatched larva at different temperatures and humidity, adapting them to the conditions of Uzbekistan and developing agro-technologies for optimal care and rearing of silkworm breeds and hybrids.

Due to the lack of special incubators on farms today, mulberry silkworm eggs are hatched in homes at different temperatures and humidity. Therefore, it was targeted to get the eggs hatched at sharply different temperatures and to determine the amount of hatched larva. When silkworm eggs were hatched at lower temperature (20-21°C) than in the norm (24-25°C), incubation period in all variants lasted 13-14 days, larva hatching lasted 4,5-5,5 days. The incubation period usually lasts 10 days at moderate temperatures and the larvae hatch within 3 days. It is obvious that when the temperature is 20-21°C during the incubation period, embryonic development is delayed for 3-4 days and larva hatching for 2 days. This leads prolongation of silkworm rearing process, causing the remaining adult worms on hot days when the leaves harden and become rough, and accordingly the yield decreases.

At the same time, the first larva hatching from eggs made 2,0-4,5 %, that is, 1,5-4,0 % more than the usual case (0,2-0,5 %), the amount of hatched eggs on the first day were less by 25-30 % compared to hatching rate of larva under moderate temperature, on the second day by 6,0-13,0 %, on the third day contrarily, they hatched more by 13-17 %, on the fourth day by 6,0-13 %. Total amount of hatched larva of “Yaponiya” breed constituted 89,5 % (Pd=0,999), in “Khitoy” breed 91 % (Pd=0,807), in Chinese hybrids and control variant 93%, showing 2,0-3,5 % lower hatching than the hatching rate of moderate condition (Table 1).

When incubation process was performed under moderate condition (temperature 24-25°C and humidity 75-80%), incubation period lasted for 10, first hatched larva was 0,5-1,5 %, larva come out of eggs during 3 days. On the 1-2nd days 87-93% larva hatched, on the 3rd day 2,5-3,0%. This rate was 6-7 % for “Khitoy” and



“Yaponiya” breeds. Total egg hatching was equal to 95,5-97,5% that was found to correspond to the requirement.

Egg hatching at higher temperature (28-29°C) than in the norm showed that, incubation period lasted for 8-9 days, decreased by 1-2 days compared to moderate temperature, larva hatching finished in 2 days, it made the higher amount on the first day (60-62%). But the amount of unhatched eggs was equal to 17,5-19,5%, total amount of hatched larva was observed to decrease by 1,05-15,5%.

The sharp difference in temperature and humidity affects not only the development of the silkworm during the incubation period, but also its survival during the larva period.

The breeds we are studying in our research are the most productive silkworm breeds of the People's Republic of China, which are considered as the main silkworm breeds in this country. We have achieved the

following results by hatching high-yielding silkworm breeds and caring for young and old instar larva. For example, when the caterpillar is reared at 20-21°C temperature and 60-65% humidity, by the end of the fifth instar, its survival indication is 88,5% in the hybrids imported from China before cocoon spinning, while in local hybrids this rate is 90%.

This means that the survival rate of caterpillar reared at low temperatures and humidity is almost the same. Their larva period duration lasted for 29-31 days, larva period of local caterpillar was found to decrease by 1-2 days. When the temperature and humidity in the cocoonery is moderate (temperature 26-27°C, humidity 75-80%), survival of larva hatched from imported eggs made average 92-94%, it was noted that this rate is less by 1-3% than in local hybrids (95,0%), while the larva period duration was the same as in control variant. Table 2 presents the related data.

Table 1
Hatching of imported silkworm eggs at different temperature and humidity (in 2015-2018)

Silkworm breeds and hybrids	Incubation period (day)	Amount of the first larva, (%)	Amount of hatched larva, %				Amount of unhatched larva (%)	Hatching of live larva (day)	Total amount of hatched larva (%)	Pd
			1-day	2-day	3-day	4-day				
At temperature 20-21°C, humidity 60-65 %										
“Yaponiya” breed	14	4,0	20,5	30,5	20,5	14,0	10,5	5,5	89,5±0,15	-
“Khitoy” breed	13	4,5	23,0	28,5	22,0	13,0	9,0	5,0	91,0±0,20	-
“Jigsong × Haoyue”	13	2,5	33,5	34,5	16,0	6,5	7,0	4,5	93,0±0,14	-
“Haoyue × Jigsong”	13	2,5	31,0	36,0	15,0	7,5	8,0	5,0	92,0±0,19	-
Ipakchi-1 × Ipakchi-2	13	2,0	34,5	36,5	16,0	6,0	7,0	4,5	93,0±0,20	-
At temperature 24-25°C, humidity 75-80 %										
“Yaponiya” breed	11	1,5	44,0	43,0	7,0	-	4,5	2,5	95,5±0,21	0,999
“Khitoy” breed	10	1,5	48,5	40,0	6,0	-	4,0	2,5	96,0±0,22	0,998
“Jigsong × Haoyue”	10	0,5	54,0	41,0	1,5	0,5	2,5	2,5	97,5±0,19	0,999
“Haoyue × Jigsong”	10	0,5	52,0	41,0	2,5	1,0	3,0	2,5	97,0±0,18	0,996
Ipakchi-1 × Ipakchi-2	10	0,5	50,0	43,0	3,0	-	3,5	2,5	96,5±0,21	-
At temperature 28-29 °C, humidity 70-75 %										
“Yaponiya” breed	9	5,5	48,5	25,5	1,0	-	19,5	2,0	80,5±0,16	-
“Khitoy” breed	8	5,0	50,5	24,0	1,5	-	19,0	2,0	81,0±0,15	-
“Jigsong × Haoyue”	8	4,5	62,0	14,0	2,0	-	17,5	2,0	82,5±0,18	-
“Haoyue × Jigsong”	8	3,0	62,0	16,0	1,0	-	18,0	2,0	82,5±0,17	-
Ipakchi-1 x Ipakchi-2	8	6,5	60,0	14,0	1,0	-	18,5	2,0	81,5±0,17	-



Figure 1. Egg hatching order of imported breeds and hybrids by variants

Table 2
Survival indicators of larva reared at different temperature and humidity (in 2015-2018)

Silkworm breeds and hybrids	Number of larva by instar, pcs						Prior to cocoon spin M±m		Larva stage duration, days M±m
	First instar	Second instar	Third instar	Fourth instar	Fifth instar	Number	%		
1	2	3	4	5	6	7	8	9	
At temperature 20-21°C, humidity 60-65%									
“Yaponiya” breed	200	187	182	178	176	175	87,5±0,33	31±0,39	
“Khitoy” breed	200	187	182	178	176	176	88,0±0,35	31±0,35	
“Jigsong × Haoyue”	200	186	181	179	178	177	88,5±0,28	30±0,41	
“Haoyue × Jigsong”	200	186	180	178	177	177	88,5±0,34	30±0,37	
Ipakchi-1 × Ipakchi-2	200	189	185	183	181	180	90,0±0,23	29±0,38	
At temperature 26-27 °C, humidity 75-80%									
“Yaponiya” breed	200	196	193	188	184	184	92,0±0,26	26±0,34	
“Khitoy” breed	200	197	193	190	187	186	93,0±0,33	25,5±0,31	
“Jigsong × Haoyue”	200	195	192	190	188	188	94,0±0,31	23±0,35	
“Haoyue × Jigsong”	200	198	194	190	187	187	93,5±0,29	23,5±0,38	
Ipakchi-1 × Ipakchi-2	200	198	196	194	191	190	95,0±0,23	24±0,36	
At temperature 29-30 °C, humidity 65-75%									
“Yaponiya” breed	200	197	195	189	179	177	88,5±0,29	24±0,38	
“Khitoy” breed	200	198	196	191	185	183	91,5±0,32	23,5±0,36	
“Jigsong × Haoyue”	200	199	198	193	186	184	92,0±0,33	22±0,37	
“Haoyue × Jigsong”	200	199	198	194	191	186	93,0±0,30	22,5±0,31	
Ipakchi-1 × Ipakchi-2	200	197	194	188	181	179	89,5±0,26	22,5±0,33	



Figure 2. Determination of survival of imported silkworm breeds and hybrids



Figure 3. Feeding and care for imported silkworm breeds and hybrids

When silkworms were reared at high temperatures (29-30°C), their survival averaged 89–93% in all variants, and the larva stage was found to be an average of 23-24 days.

The growth, development, and disease suffering of silkworms were also observed during the experiment. The larva developed well and healthy until the 3rd instar in all variants. From the 4th instar, it was found that they are mainly susceptible to bacterial and fungal diseases.

CONCLUSION

Analysing the results of research on the effect of sharply different temperatures and relative humidity of air on the hatching of silkworm eggs, the following conclusion can be drawn.

First, the fact that the temperature in the incubator is below normal during the period of egg revitalization slows down the embryonic development process in the egg and delays the larva hatching and the rearing period. During the incubation period, when the temperature exceeds the norm, the incubation period is shortened by one day, and larva hatching from eggs is reduced by 17.5-19.5%. This is because high temperatures accelerate considerably the physiological, biochemical and metabolic processes in the egg. As a result, the normal development of the embryo is disrupted, and the hatched larva become weak and susceptible to disease. Therefore, when incubating eggs, it is advisable to have a temperature of 24–25°C and a humidity of 75–80%.

Second, the percentage of revitalization and hatching of eggs of imported silkworm breeds and hybrids does not exceed that of local eggs. Therefore, we recommend using local silkworm eggs without incurring additional costs (foreign seeds are two to three times more expensive), and instead of spending money on eggs from abroad to spent on silkworm breeding enterprises in the Republic.

It was defined that when larvae from imported eggs were fed at low (20-21°C) and above normal (29-30°C) temperatures, the survival of the larvae decreased by 5-6% and the larva stage prolonged to 7-9 days. This case causes the silkworms to be left to feed on hot summer days. As a result, due to the roughing and hardening of the leaves, the caterpillars are not fed enough and spin small and poor quality cocoons. Having considered all of this, it can be concluded that it is advisable to keep the imported eggs at a temperature of at 24-25°C to hatch, and to rear young larva at a temperature of 26-27°C and 75-80% humidity, and the adult larva at a temperature of 25-26°C and 70-75% humidity.

REFERENCES

1. Decree of the President of the Republic of Uzbekistan "About Actions strategy for further development of the Republic of Uzbekistan" from February 7, 2017, numbered PD-4947. - Tashkent, 2017.
2. Decree of the President of the Republic of Uzbekistan "About the measures on establishment of activity of the association "Uzbekpaksanoat"" from March 29, 2017, numbered PD-2856. - Tashkent, 2017. pp.1-5.
3. Decree of the President of the Republic of Uzbekistan "About the additional measures on further development of sericulture sector" from March 20, 2018, numbered PD-3616. - Tashkent, 2018. pp.1-4.
4. Akhmedov N.A. (1992). Egg hatching of silkworm. Tashkent, pp. 6-7.
5. Akhmedov N.A. (1998). The effect of contrast temperature and humidity on silkworm egg hatching. Silk. Tashkent, 1998. №4. pp. 22-23.
6. Bekkamov Ch. (2008). The effect of sharply changable temperature and humidity on survival of silkworm. Republican scientific-practical conference materials. Tashkent. pp. 124-127.
7. Umarov Sh.R. (2004). The effect of rearing pure quality silkworms by new technology in summer and autumn on biological indicators of cocoon. Scientific



basis for solving current problems in the field of silkworm breeding. Tashkent. pp. 208-214.

8. Umarov Sh.R., Nasirillaev B.U., Giyasova K.S. (2016). *Influence of selection of breeding cocoons by their compactness on silkworm embryonic and postembryonic viability. Uzbekistan agriculture. – Tashkent, №8. pp. 41-42.*
9. Umarov Sh.R., Nasirillaev B.U., Giyasova K.S. (2017). *Comparative analysis of vitality and productivity traits of silkworm in elite population made by a new method. Zooveterinary, №5. pp.39-40.*



A STUDY ON CUSTOMER SATISFACTION OF WHIRLPOOL HOME APPLIANCES

Dr. M. Kalimuthu

*Assistant Professor, Department of Commerce with Professional Accounting,
Dr. N.G.P. Arts and Science College, Coimbatore*

Ms. Sandhiya. D

*Student, Department of Commerce with Professional Accounting
Dr. N.G.P. Arts and Science College, Coimbatore*

ABSTRACT

After years of rationing and shortages, the 1950 were a period of 'economic prosperity, high employment and great technological development. Many returned servicemen got married, established homes and raised families. During this period, Australians enthusiastically adorned their homes with a dazzling range of new domestic appliances. Hire-purchase schemes allowed people to take products home and pay for them in instalments. During the 1955, the role of women was generally considered to be that of the 'homemaker'. Bright television and magazine advertisements encouraged women to stay at home and create a domestic haven for their families using the new appliances on offer. These devices promised to raise standards of living and release housewives from the shackles of household chores. Electric stoves, refrigerators, toasters and kettles revolutionized the kitchen, and vacuum cleaners and washing machines shaved hours off time spent cleaning. Women could enjoy more leisure time while still creating a clean, comfortable home for their families. Many women chose to join the paid workforce, changing the shape of the Australian labour market forever.

KEY WORDS: *Satisfaction of customer, Price, Quality.*

INTRODUCTION

Home Appliances are those things which make a house into home. Everything that is needed to make a home comes under the category of home appliances. The things that come under the name of home appliances can be divided into two sub categories. They are,

- Kitchen appliances
- Home appliances

Kitchen happens to be the most important part of home. If the kitchen is equipped with all the kitchen appliances then the lady of the house feel happy as her work load is considerably reduced.

Other home appliances also play a very important part in reducing the work load and making life much easier. Some of the things are,

- Freezers
- Refrigerators
- Sewing machine
- Washing machine

NEED FOR THE STUDY

Customer satisfaction provides an indication of how successful the organization is providing products and/or services to the market place. Organizations need to retain existing customers while targeting noncustomers. So, to retain the customers for longer time the marketer



has to know the customer satisfaction levels. Thus, this study is conducted to know the satisfaction levels of customers of whirlpool products.

OBJECTIVES OF THE STUDY

- To know about profile of whirlpool.
- To find out the customer satisfaction of whirlpool home appliance.
- To find out the various factors influencing in the customer to purchase.

RESEARCH METHODOLOGY & DATA COLLECTION

This study assumes the characteristics of descriptive. The study is based on primary data collection. The secondary data was collected from the articles, journals, newspaper and websites. The study is conducted on the basis of a convenient sample method for 120 RESPONDENTS. The sample size comprises of different types of consumer who are potential users of whirlpool home appliance like employees, students, and professional etc.

REVIEW OF LITERATURE

Janaki, P (2013) in their study entitled, "Marketing Stimuli in Purchase of Home Appliances from Customer Perspectives", explains that marketing strategy is the game plan which the firms must adhere to, in order to outdo the competitor or the plans to achieve the desired objective. The people consume things of daily use, and buy these products according to their needs, preferences and buying power. The objectives of the study are to study the purchase decision behavior relating to home appliances and to analyse customer response to the marketing stimuli of home appliances.

Senthil Kumar, (2013) in their study entitled, "A Study on Consumer's Attitudes towards Washing Machine", which explains that in the modern technological world many innovations and new apparatus are invented by the man for reducing the work burden of the layman. Especially a lot of home appliances are introduced to save the valuable time of the working women. Because in the hurry bury world both husband and wife are working. So the modern

women are not having sufficient time to do domestic work like washing their dresses. In this situation washing machine becomes an integral part of their home. The washing machine is not only to reduce their physical work but also it gives quality washing.

HISTORY & PROFILE OF THE STUDY

In 1911, the Upton Brothers (Louis, Frederick and Emory) created the Upton Machine Company in St. Joseph, MI to produce electric. Motor-driven wringer washers. Joined with Sears, Roebuck and Co. in 1916, the Upton-manufactured washers sold faster than the brothers could manufacture them, thus creating the mutually beneficial relationship between Sears and Whirlpool. Since the 1975, Whirlpool has been a pioneer of energy and water efficiency measures in its research and development practices. Whirlpool continues its long history of being involved with the US. Department of Energy and US. Environmental Protection Agency ENERGY STAR program and has been named ENERGY STAR Partner of the Year seven times. "Whirlpool is delighted to once again be named an Energy Star partner. These appliances save money for our customers by lowering their utility bills and help protect the environment," says David L. Swift, Whirlpool's Executive Vice President for North America. Today the Whirlpool Corporation remains the largest North American supplier of major appliances to Sears under the Kenmore brand. Internationally, Whirlpool is also recognized for energy efficient appliances, as well as for their commitment to environmental packaging, production, and design. Whirlpool is the world's leading manufacturer and marketer of major home appliances, becoming a trusted household name all over the world. Located in Benton Harbour, MI, Whirlpool's Corporate Headquarters focuses on the social responsibilities to their community and to the environment. "At Whirlpool Corporation we take our environmental responsibilities very seriously. Just as we have taken a global approach to our home appliance business, we believe our world's environmental issues must be addressed in a similarly comprehensive way," says Jeff M. Fitting, President, Chairman and CEO of Whirlpool Corporation.

**ANALYSIS****TABLE SHOWS THE FACTORS WHICH INFLUENCE THE RESPONDENTS TO BUY WHIRLPOOL APPLIANCES**

S. NO	PARTICULARS	1	2	3	4	5	TOTAL SCORE	RANK
1	Advertisements	26(5) 130	30(4) 120	20(3) 60	20(2) 40	24(1) 24	374	5
2	Guaranty & Warranty	52(5) 260	32(4) 124	13(3) 39	12(2) 24	11(1) 11	458	2
3	Payment method	12(5) 60	48(4) 192	32(3) 96	11(2) 22	11(1) 11	381	4
4	Offers	25(5) 125	34(4) 136	22(3) 66	18(2) 36	21(1) 21	384	3
5	Response	24(5) 120	25(4) 100	19(3) 57	30(2) 60	22(1) 22	359	6
6	Customer service	65(5) 325	36(4) 144	12(3) 36	1(2) 2	1(1) 1	508	1

(Source: Primary data)

INTERPRETATION

The above table shows that the Customer service is rank 1, Guaranty & Warranty are rank 2, Offers is rank 3, Payment method are rank 4, Advertisement is rank 5, Response is rank 6, Convenience is rank 7, Payment method is rank 8.

INFERENCE

Customer service is ranked 1 based on the respondents ranking towards the factors influencing to buy the Whirlpool products.

**TABLE SHOWING THE SATISFACTION OF THE RESPONDENTS
IN PRICE**

S.NO	FACTORS	NO.OF RESPONDENTS	LIKERT SCALE VALUE(X)	TOTAL
1	Highly Satisfied	19	5	95
2	Satisfied	89	4	356
3	Neutral	11	3	33
4	Dissatisfied	0	2	0
5	Highly dissatisfied	1	1	1
	TOTAL	120		485

(Sources: Primarydata)

$$\begin{aligned} \text{Likert scale} &= \frac{\sum(fx)}{\text{total no. of respondents}} \\ &= \frac{485}{120} \\ &= 4.04 \end{aligned}$$

INTERPERTATION :Likert scale value is 4.04 greater than the middle value(3). So the consumer are satisfied in the Price.

TABLE SHOWING INTEREST OF CHOOSING WHIRLPOOL BRANDS OF THE RESPONDENTS

S. NO.	FACTORS	NO. OF RESPONDENTS	PERCENTAGE
1	Price	32	28
2	Quality	63	52
3	Convenient	25	20
	TOTAL	120	100

(Source: Primary data)

INTERPRETATION

The above table shows that 28% of the respondents chose Whirlpool for the price, 52% of the respondents chose Whirlpool for Quality, 20% of the respondents chose Whirlpool for their Convenience.

INFERENCE

Majority, 52% of the respondents chose Whirlpool for the Quality.

FINDINGS

SIMPLE PERCENTAGE

- 68% of the respondents are Male.
- 34% of the respondents are below 26-30 years.
- 49% of the respondents are Postgraduates.
- 50% of the respondents are Unmarried.
- 42% of the respondents are Public sector.
- 46% of the respondents are earning Rs.10,001 – Rs.20,000.
- 55% of the respondents are joint family.



- 52% of the respondents choose Whirlpool for the Quality.
- 53% of the respondents agree Whirlpool is latest technology.
- 51% of the respondents are comfortable with Whirlpool Home Appliances.
- 41% of the respondents came to know about the brand by their friends & Relatives.
- 44% of the respondents are convenient to purchase the Whirlpool appliance by Debit & Credit card.
- 64% of the respondents tell that the attitude of handling complaints towards them is different.
- 50% of the respondents expect from 1year – 3years for the average life span of the Whirlpool Appliances.
- 55% of the respondents think that the Whirlpool showrooms are at right location.
- 50% of the respondents have Whirlpool products and also 50% of the respondents do not have the Whirlpool products in their home.

LIKERT SCALE

- Likert scale value is 4.60 greater than the middle value (3). So the consumers are agreeing in the quality.
- Likert scale value is 4.04 greater than the middle value (3). So the consumers are agreeing in the Price.
- Likert scale value is 3.43 greater than the middle value (3). So the consumers are agreeing in the comfort.
- Likert scale value is 3.2 greater than the middle value (3). So the consumers are agreeing in the collection.
- Likert scale value is 3 greater than the middle value (3). So the consumers are agreeing in facilities.

RANK ANALYSIS

Customer service is ranked 1 based on the respondents ranking towards the factors influencing to buy the Whirlpool products.

SUGGESTIONS

- Customer care should be taken for efficient and timely response to the customer problems.
- Outlet to the back office operation should be fast to solve the customer problems.

- The executives shouldn't talk on their mobiles while interacting to the customer to the customer inside the whirlpool products.
- The executives should be given training on the aspects where they are lacking in (like a smile to the customer, solving the queries at lease time. Making feel the customer comfortable, updating the new Airtel production to all the customers.

CONCLUSION

This present study concluded that, the consumer behaviour and preference have a great impact on the home appliance products. The home appliances like Television, Air Conditioner, Refrigerator, Washing Machine and Mixer Grinder, were once considered as life purchase but now people become more open to the idea of exchanging their old appliances for new ones. The relationship between consumer behaviour and home appliance products can thus be seen as an individual's purchases and use of products and services where these choices constitute part of his life style expression and its reflection.

REFERENCE

1. Janaki, P (2013) "Marketing Stimuli in Purchase of Home Appliances from Customer Perspectives", *International Journal of Sales & Marketing Management Research and Development (IJSMMRD)*, Vol. 3, Issue 2, pp. 23-30.
2. Senthil Kumar,(2013) "A Study on Consumer's Attitudes towards Washing Machine", *IJEMR*, Vol.3, Issue.1, pp.22-28.
3. Vijayalakshmi, S (2013) "An impact of consumer buying behaviour in decision making process in purchase of electronic home appliances in Chennai (India): an empirical study", *Elixir Marketing Management*, pp.15267-15273.
4. Natarajan , M (2013) "Consumer Behaviour Towards Selected Household Appliances in District", *Premix International Journal of Commerce and Management Research*, Vol. 1, Issue No.1, pp.1.
5. Srinivasan Rao (2013) "A Study on Customer Preference of LG Lap-Top", *International Journal of Computational Engineering Research (ijceronline.com)* Vol. 3 Issue. 3, pp.23423.



A STUDY ON CONSUMER SATISFACTION TOWARDS DATSUN CARS WITH SPECIAL REFERENCE TO COIMBATORE CITY

P.Dhanya¹

*¹Assistant Professor, Department of commerce with Professional Accounting,
Dr. N.G.P. Arts and Science College, Coimbatore*

M.Saravanan²

*²Under Graduate, Department of commerce with Professional Accounting,
Dr. N.G.P. Arts and Science College, Coimbatore*

ABSTRACT

Consumers are the final beneficiary of the retailing activities. No discussion about what the cars used by the consumers, it is all about satisfy the consumer needs. By knowing this the risk has been taken to examine the factors influencing the consumers to choose Datsun cars for their use. This study is completely based on the primary and secondary data which has been collected through questionnaires and journals respectively. The information are collected in Coimbatore city.

INTRODUCTION

Satisfaction is essential factor for both consumer and organization. Satisfaction is an subjective concept and hard to determine. It relies upon numerous factors and differs from person to person and product to product. The importance of consumer satisfaction in strategy development for consumer and market oriented can't be underdetermined. Day to day it has become important factor for every single organization to update the level of consumer satisfaction. Consumer satisfaction is a term is utilized in marketing, it's a measure how product and service provided by the organization meet or surpass consumer needs.

As per ISO 9000, the consumer satisfaction is when the consumer opinion on the product is meets its requirements. Consumer satisfaction is a highly personal assessment. Consumer satisfaction is a measure of post purchase behavior of the consumer. If consumer expectations meet with the perceived value of goods and service then consumer is satisfied but if

the perceived value of goods and service is less than the consumer expectations than consumer is dissatisfied and if the perceived value exceeded the expected value of the goods and service than the customer is delighted. Likewise, consumers want the best possible product at lower price.

The perception of the best product or service at lower cost with safety impact the business and customer portion essentially. Therefore consumer satisfaction is defined as "The number of the consumer or percentage of the total consumers, whose reported an experience with a firm, it product or its service exceeds specified satisfaction goods". Consumer satisfaction is very important for any business whether it sale the product or service in such a case that the consumer is satisfied then they make the repeat purchase and passes the information to different people like their companions, neighborhoods, relatives and so on about their great experience and satisfied consumers pass information to five others concerning their great experience.



SCOPE OF THE STUDY

The scope contains the consumer satisfaction of Datsun company cars. This study has been conducted with the assist of available information from the company database. The study brings the Datsun cars brand images in the market and to know the familiarity among the car consumers. This study gives the information about the consumer satisfaction on different cars in the same Datsun Company. This study reveals information about satisfaction level of consumers on Datsun cars when compared to the other cars.

STATEMENT OF THE PROBLEM

In today world the cars are considered as their pride especially in Indian society. So the people get confusion about what cars that they have to purchase. In this case the people opinion on Datsun cars may be differing when they compared to other cars. Some individuals may not realize the services lend by the Datsun cars showrooms in urban areas like Coimbatore city. More peoples may not have the true knowledge on Datsun cars. The satisfaction on Datsun cars will be differing from person to person. "A Study on consumer satisfaction in Datsun cars" will reveals these above observed issues.

OBJECTIVE OF THE STUDY

- To analyse the consumer satisfaction towards Datsun cars.
- To study about consumers awareness to different cars and models of Datsun company.
- To identify the service offered by Nissan-Datsun showrooms in Coimbatore city.
- To study the consumers opinion on Datsun cars in Coimbatore city.

RESEARCH METHODOLOGY

Research design

The research design is the procedure used for collecting the data and analyzing it for arriving at conclusion. The design adopted for this study is descriptive nature. The study is conducted for consumer satisfaction of Datsun cars in Coimbatore city.

Area of the study

Selected location for the study is Coimbatore.

Sample size

The study is contains of 120 respondents selected from the Coimbatore city.

Source of data

The data is collected through in two ways:

- **Primary data:** The primary data was gathered freshly and thus it was unique. It has been gathered through questionnaire. The questionnaires were issued to the respondents where they visited selected show rooms located in Coimbatore.
- **Secondary data:** Secondary data are information which have been just been gathered by someone. Its main sources are Journals, Newspapers, Magazines, and Internet etc.

Sampling technique

Convenience sampling technique was adopted for the collecting the required data.

Proposed tools

Percentage analysis method and Ranking analysis method where utilized to break down the information.

LIMITATIONS

- The present study has been conducted on the Datsun cars consumers at only in Coimbatore city due to time contract.
- The study has been conducted at only in Coimbatore city. So, result may be varying from place to place.
- Due to time contract just 120 quantities of respondents were considered.
- The result is completely relies upon the collected data which was presented by the respondent.

REVIEW OF LITERATURE

Suriya, Vinotha and Ganga (2015) made study on "Service Quality and consumer Satisfaction towards Tata Indica at VST Motors in Cuddalore." Descriptive research plan was executed. 120 respondent were taken as the sample size in this study. Illustrative measurements and one way ANOVA were utilized for data study. The scientist reasoned that lion's share of the consumers were hoping to limit the consumer holding up time and decrease the organization rate and on both appearance and conveyance of organization.

Akhila and Ali Ashar (2015) made "A Study on Consumer satisfaction towards Maruti Suzuki in Coimbatore." Convenience sampling method was used for gathering required information. 150 respondents were taken as sample size. Rate study and Chi quare test were received for study the gathered required



information. The study found that there is no critical connection between type of gender and maruti cars. The results are that expanding pattern, simultaneously they security and security, better, simple taking care of, and so forth.

Vijayakanth, Santosh Kumar and Hari Roa (2014) conducted research on "A Study on consumer Satisfaction Index in Multi Brand Car Service Centre across Karnataka." Quantitative research configuration was used in this study. Graphic insights were used for information study. The example size was 100 respondent. The study found that Maruti vehicle consumers across Karnataka were happy with the facilities offered by the Multi brand organization focus. The study helps to shows that satisfaction rate was more than dissatisfaction rate.

COMPANY HISTRY

Datsun or Datsun Motor Corporation is an automobile brand owned by Nissan. Datsun's original production run began in 1931. From 1958 to 1986, only vehicles exported by Nissan were identified as Datsun. By 1986 Nissan had phased out the Datsun name, but re-launched it in June 2013 as the brand for low-cost vehicles manufactured for emerging markets.

In 1931, Dat Motorcar Co. choose to name its new small car "Datson", a name which indicated the new car's smaller size when compared to the DAT's larger vehicle already in production. When Nissan took control of DAT in 1934, the name "Datson" was changed to "Datsun", because "son" also means "loss" in Japanese and also to honor the sun depicted in the national flag – thus the name Datsun: Dattosan. Nissan phased out the Datsun brand in March 1986.

The Datsun name is internationally well known for the Fairlady (Datsun Fairlady). Datsun Fairlady was a series of roadsters produced by the Nissan in the 1960’s. The series was a predecessor to the Z-car in the Fairlady line, and offered a competitor

to the European MG, Triumph, Fiat and Alfa Romeo sports cars. The line began with the 1959 S211 and continued through 1970 with the SP311 and SR311 lines.

In Japan, it represented one of three core products offered by Nissan at Japanese Nissan dealerships called Nissan Shop, alongside the Datsun Truck and the Datsun 1000. The Datsun SRL 2000 was the two-seat roadster that made their name. Paul Newman started his racing career in one. It had a potent 1,982cc overhead cam engine with dual SU type side draft cabs and a five-speed transmission. In 1991, Nissan introduced a limited number two-door convertible styled in a retro appearance to the Datsun Sports called the Nissan Figaro.

DATA ANALYSIS AND INTERPRETATIONS

In this chapter the analysis and interpretation of the study on consumer satisfaction of Datsun cars with special reference to Coimbatore city is based on the information supplied by a sample of 120 respondents selected from Coimbatore city.

This chapter contains two different analyses namely:

- Simple percentage analysis.
- Rank analysis.

SIMPLE PERCENTAGE ANALYSIS

Simple percentage analysis is one of the basic statistical tool which is widely used in the analysis and interpretation of primary data. It deals with the number of respondents response to a particular question in percentage arrived from the total population selected for the study.

The simple percentage can be calculated by using the formulae,

Actual respondents

Simple percentage analysis = ----- * 100

Total number of respondents

PREFERENCE TOWARDS THE DATSUN CARS BY THE RESPONDENTS

DATSUN CARS	No. OF RESPONDENTS	PERCENTAGE
DATSUN GO	18	15
DATSUN GO PLUS	77	64.2
DATSUN REDI- GO	25	20.8
TOTAL	120	100

**INTERPRETATION**

It is observed from the above table that the 15% of the respondents were preferred to Datsun Go, 41.7% of the respondents were preferred to Datsun Go Plus and 20.8% of the respondents were preferred to Datsun Redi- Go.

INFERENCE

Hence, majority 64.2% of the respondents were mostly preferred to Datsun Go Plus cars.

EFFECTIVE CONDITION LONGLASTING PERIOD OF DATSUN CARS IN THE VIEW OF RESPONDENT

EFFECTIVE CONDITION LONGLASTED PERIOD	No. OF RESPONDENTS	PERCENTAGE
LESS THAN ONE YEAR	12	10
1- 3 YEARS	59	49.2
3- 5 YEARS	27	22.5
5- 10 YEARS	22	18.3
TOTAL	120	100

INTERPRETATION

It is observed from the above table says that effective condition of the new Datsun cars long lasted by 10% of the respondents says less than one year, 49.2% of the respondents says 1- 3 years, 40% of the respondents says 3- 5 years and 0.8% of the respondents says 5- 10 years.

INFERENCE

Hence, majority 49.2% of the respondents says that effective condition of the Datsun car was long lasted up to 1- 3 years.

ATTRACTING EXTERNAL FACTORS ON DATSUN CARS TO THE RESPONDENTS

EXTERNAL FACTORS	No. OF RESPONDENTS	PERCENTAGE
APPEARANCE	18	15
FRONT VIEW	51	42.5
SIDE VIEW	45	37.5
REAR VIEW	6	5
TOTAL	120	100

INTERPRETATION

It is observed from the above table says that attracting external factors is 15% of respondents says appearance, 42.5% of the respondents says front view, 37.5 of the respondents says side view and 5% of the respondents says rear view in Datsun cars.

INFERENCE

Hence, majority 42.5% of the respondents says that front view is the attracting external factor in Datsun cars.

RANK ANALYSIS

A ranking is a relationship between a set of items such that, for any two items, the first is either 'ranked higher than', 'ranked lower than' or 'ranked equal to' the second.

**COMPARATIVE RAND PROVIDED FOR VARIOUS FACILITY IN DATSUN CARS**

VARIOUS FACILITIES	1(10)	2(9)	3(8)	4(7)	5(6)	6(5)	7(4)	8(3)	9(2)	10(1)	TOTAL	RANK
PRICE	21 210	7 63	12 96	10 70	11 66	5 25	8 32	11 33	26 52	9 9	120 656	VI
SAFETY	15 150	26 234	7 56	13 91	8 48	12 60	6 24	21 63	11 22	1 1	120 749	II
DRIVING & SEETING COMFORT	9 90	4 36	21 168	13 91	13 78	12 60	22 88	15 45	6 12	5 5	120 673	V
POWER & PICK UP	17 170	14 126	12 96	22 154	12 72	14 70	15 60	8 24	3 6	3 3	120 781	I
MILEGE	4 40	14 126	14 112	9 63	35 210	17 85	8 32	7 21	7 14	5 5	120 708	III
MAXIMUM SPEED	11 110	7 63	14 112	18 126	13 78	25 125	9 36	3 9	11 22	9 9	120 690	IV
STYLING	9 90	9 81	12 96	16 112	8 48	8 40	20 80	16 48	13 26	9 9	120 630	VII
AFTER SALE SERVICE	7 70	16 144	15 120	7 49	8 48	8 40	13 52	25 75	8 16	13 13	120 627	VIII
MAINTANING COST	15 150	12 108	7 56	4 28	5 30	9 45	7 28	7 21	25 50	29 29	120 545	IX
BRAND NAME	12 120	11 99	6 48	8 56	7 42	10 50	12 48	7 21	10 20	37 37	120 541	X

INTERPRETATION

It is observed from the above table that Power and Pick up ranked first, Safety ranked second, Milege ranked third, Maximum speed ranked fourth and driving, Seeting comfort ranked fifth. Price ranked sixth, Styling ranked seventh, After sale service ranked eighth, Maintaning cost ranked ninth and Brand name ranked tenth

FINDINGS, SUGGESIONS AND CONCLUSION**FINDINGS FORM SIMPLE PERCENTAGE**

- Majority 76.7%of the respondents are male.
- Majority 50% of the respondents are between 21-30 years of age.
- Majority 72.5% of the respondents are under graduates.
- Majority 42.5% of the respondents are getting a salary of 500000-1000000.
- Majority 59.2% of the respondents are used the Datsun cars for the period of 1-5 years.
- Majority 57.5% of the respondents are belongs to semi-urban.

- Majority 50% of the respondents are using the Datsun cars for the personal uses.
- Majority 41.7% of the respondents are using the Datsun cars for regular period of weakly once.
- Majority 59.2% of the respondents were suggested to buy the Datsun cars.
- Majority 42.5% of the respondents are came to know about Datsun cars by media.
- Majority 58.3% of the respondents were recommended others to buy the Datsun cars.
- Majority 64.2% of the respondents were mostly preferred to Datsun Go Plus cars.
- Majority 52.5% of the respondents were used EMI payment while purchasing the Datsun cars.
- Majority 49.2% of the respondents says that effective condition of the Datsun car was long lasted up to 1- 3 years.
- Majority 54.2% of the respondents says that fuel consumption new Datsun cars were good to its efficient work.



- Majority 42.5% of the respondents says that front view is the attracting external factor in Datsun cars.
- Majority 51.7% of the respondents made their company services on Datsun cars by 12 month once.
- Majority 72.5% of the respondents says that spare parts for Datsun cars are easily available in the Coimbatore city.
- Majority 52.5% of the respondents says that driving comfort of Datsun cars are good by comparing other cars.

FINDINGS FROM RANK ANALYSIS

- It is observed that the comparative position of Datsun cars when compared to other cars that Hyundai ranked first, Tata Motors ranked second, Datsun ranked third, Maruti ranked fourth and Other car brands ranked fifth.
- It is observed that the comparative position of various facility provided by the Datsun cars that Power and Pick up ranked first, Safety ranked second, Mileage ranked third, Maximum speed ranked fourth and driving, Seating comfort ranked fifth. Price ranked sixth, Styling ranked seventh, After sale service ranked eighth, Maintaining cost ranked ninth and Brand name ranked tenth.

SUGGESIONS

They are few suggestions are made to improve Datsun cars:

- They has to improve the Internally adjustable wing mirrors which is absents in Datsun cars.
- There is no dual airbags available in the Datsun cars. It gets only single airbags for driver.
- After the sales, service is not up to the mark which satisfy the consumer that should make improved.
- Some of the rare Spare Parts are not available in the open market in cities like Coimbatore. So, it has to be improved.
- The service charges should be reasonable to the service made in the Datsun cars show rooms.

CONCLUSION

In this study conducted mostly Datsun cars are purchased on EMI payments. Datsun cars are mostly used for the personal uses and having the Datsun cars

for the period of 1-5 years. The Datsun cars are mostly used by the peoples from Semi-Urban. The Datsun cars were known to the market by media advertisement, and mostly this Datsun cars were suggested others to buy by the respondents. In case of level of consumer satisfaction, it was found that the effective condition of new Datsun cars were long lasted up to 1-3 years and the fuel consumption is good. Consumer says that front view is the most attracting external factor in Datsun cars. Most of the consumer satisfied with preference of Datsun Go Plus cars. The consumer says that they have made their company service yearly once and Spare Parts for Datsun cars are easily available in the Coimbatore city. Nearly half of the consumer says that driving comfort of Datsun car is good while comparing brands of cars. Finally the overall opinion on Datsun cars is good and mostly satisfied by the consumer.

REFERENCE

1. **Suriya, Vinotha and Ganga (2015)** made study on "Service Quality and consumer Satisfaction towards Tata Indica at VST Motors in Cuddalore". *International Journal of Scientific and Research Publications, Volume 5, Issue 4, April 2015, ISSN 2250-3153.*
2. **Akhila and Ali Ashar (2015)** made "A Study on Consumer satisfaction towards Maruti Suzuki in Coimbatore." *International Journal of Management and Commerce Innovations ISSN 2348-7585 (Online), Vol. 2, Issue 2, pp: (583-587), Month: October 2014 - March 2015.*
3. **Vijayakanth, Santosh and Roa (2014)** conducted research on "A Study on consumer Satisfaction Index in Multi Brand Car Service Centre across Karnataka." *Journal of Information, Knowledge and Research in Mechanical Engineering ISSN 0975 - 668X| NOV 13 TO OCT 14 | VOLUME - 03, ISSUE - 01*



A STUDY ON CONSUMER SATISFACTION TOWARDS FEMALE BEAUTY CREAMS IN HIMALAYA PRODUCTS (WITH SPECIAL REFERENCE TO COIMBATORE CITY)

Dr. M. Kalimuthu

*Assistant Professor, Department of commerce with Professional Accounting,
Dr.N.G.P Arts and Science College, Coimbatore*

M. Keerthana

*III B.Com (PA), Department of commerce with Professional Accounting,
Dr.N.G.P Arts and Science College, Coimbatore*

ABSTRACT

Today people are more beauty conscious. Face cream plays an important role in the life of people. Face cream is usually applied to the external skin. Face creams are formulated not as medicine by simply to smooth, rehydrate and soften the skin. The companies use to distinguish their product from others in the market by symbol, mark, logo, name, word, sentence or a combination of these items. It has been found out that most of the customers buy face cream products based on brand factors. For

INTRODUCTION

The Essence of marketing is an exchange or a transaction, intended to satisfy human needs or wants. That is, marketing is a human activity directed at satisfying needs and wants, through an exchange process. A demand is a want for which the consumer is prepared to pay a price. A want is anything or a service the consumer desires or seeks. Wants become demands when backed by purchasing power. A need is anything the consumer feels to keep himself alive and healthy. A transfer may receive nothing in return. The aim of marketing is to make sales in order to earn reasonable profit for the producer. Himalaya product has its wealth of knowledge and research, in natural herbal remedies, to formulate a range of personal care products that cater to our daily health needs. The global world we are living in sets of stereotypes that become models. This desire and trends are growing and seen as a gold mine for the beauty care market. Beauty care products imply psychologically that customers are taking care of their hygiene, beauty and healthiness by using some products items to support. Today people are more

beauty. Most people would like to be beautiful, healthy and good looking. The global world we are living in sets of stereotypes that become models. This desire and trends are growing and seen as a gold mine for the beauty care market. Today people are more beauty conscious. Face cream plays an important role in the life of people. Face cream is usually applied to the external skin. Face creams are formulated not as medicine by simply to smooth, rehydrate and soften the skin. The companies use to distinguish their product from others in the market by symbol, mark, logo, name, word, sentence or a combination of these items.

STATEMENT OF THE PROBLEM

Different varieties of the beauty cream products are available in the market female customers in coimbatore prefer the variety of products for high quality, low price and attractive wrappers. Most of the consumers are satisfied with quality products and some of the female customers prefer other factors each product differs from one to another in terms of price, quality, quantity, offers, advertisement etc. The



competition is severe and the manufacturer has to consider the opinion of the female customer in Himalaya has been found out that most of the customers buy face cream products based on brand factors.

OBJECTIVES OF THE STUDY

- The study on social demographic profile of the customer
- To measure the level of awareness among customer towards Himalaya beauty cream product.
- To ascertain the factors that influencing the customer on choosing of Himalaya beauty cream product.
- To analyze the customer opinion and satisfaction with specific reference to Himalaya beauty cream product.

SCOPE OF THE STUDY

- The present study will be helpful in understanding the female customer attitude of the different strata people in the Indian society especially in Coimbatore city.
- Any substitutes of fairness creams like soap or natural products will not be considered. It will also helpful in studying the effect of beautycream purchase of the study specifically among the segment under consideration

RESEARCH METHODOLOGY

For collection of primary data and secondary data. A well structured interview schedule was prepared based on the objectives of the study. The data required for the study were gathered using questionnaires. Based on the questionnaires simple percentages were worked out to study the customer satisfaction.

TYPES OF DATA

1. Primary data
2. Secondary data

Primary Data

A questionnaire is used as a tool for the systematic collection of relevant information. A well interview schedule consisting of simple questions has been prepared and directed to the respondents.

Secondary Data

Secondary data is collected from the company's websites.

SAMPLING DESIGN

The location

The survey was conducted in Coimbatore. It is considered to be one of the major city in tamil nadu.

Determination of sample

The size of sample is 120. It was decided arbitrarily. The target group of the respondents are the consumer of the Himalaya female users. The limitation of the time, energy and research facilities compared to the limit size to 120.

TOOLS USED FOR THE STUDY

- Simple percentage method
- Linkert scale analysis
- Rank analysis

LIMITATIONS OF THE STUDY

- The samples have been take only from 120 respondents.
- This result was conducted only in particular area so this result cannot suitable to other places.
- Data collected under this technique is subjective nature therefore they may not easily lead to quantitative checks

REVIEW OF LITERATURE

Abhiji bhandari,(2000) [1] “ Making loyalty pay” retention done through a loyalty programme can help building a direct marketing database. The cost of retaining a customer is just one tenth of the cost acquiring new states new states ABHIJIT Bhandari chairman of royal images direct marketing limited.

Bass Frank. M., (2001)[2] “ A non rational buyer does not plan hia buying it is equally logical to assume that this buying the product and especially a specific brand is random or probabilities this means that the buyer is not looking for a particular brand but picks up the brand available. This is probilistics switching behavior.

Deepallsingh (2001)[3] in his study enticed “entitled, consumer behaavoieur and banking retail product and analysis”, stress thst the borrower sttitudes is an importants factor for the improvement of housing loan schemes.

Dr. Raja sekar.N. (2002)[4] Conduted a fairness creams a study on market trends and product preference of the study has reveled very significant finding like skin care product showed brand equity should also be developed to sustain in the market.



INTRODUCTION

The Himalaya drug company was founded in 1930 by Mr.M.MANAL with a clear vision to bring Ayurvedha to society in a contemporary form and to unravel the mystery behind the 5000 year old system of medicine. This included referring to ancient ayurvedic texts, selection in indigenous herbs and subject the formulation to modern pharmacological, toxicological and safety tests to create new drugs and therapies. The company is focused on developing safe, natural innovation remedies that will help people lead richer, healthier live today, himalaya products have been endorsed by over 2, 50,000 doctors around the globe and customers in over 90 country"s rely on himalaya for their health and personal care needs. Himalaya herbals is the range of 100% natural and safe products with rare herbs collected from the foothills of the Himalayas. Each product combines the best of Ayurvedha with years of dedicated research. Batch to batch performance and complete purity and safety are assured through the application of advanced pharmaceutical technology at every stage of manufacture. So, go ahead and give us a try! We guarantee that you will be pleased.

HISTORY

Every year, 300 million Himalaya products enter the homes of customers around the world. With a range of over 300 healthcare and personal care products including brands like Liv.52, Cystone, and Bonnisan, we touch the lives of millions of customers worldwide, giving them products that help them lead healthier,

enriched lives. Himalaya's story began way back in 1930. A curious young man riding through the forests of Burma saw restless elephants being fed the root of a plant, Rauwolfia serpentina, which helped pacify them. Fascinated by the plant's effect on elephants, this young man, Mr. M. Manal, the founder of Himalaya, wanted to scientifically test the herb's properties. With no money and only a pocketful of dreams, he pawned his mother's jewellery to buy a hand-operated tabulating machine. The years that followed were a time of endurance and a test of the young man's patience, strength and passion. He spent his days learning about herbs from neighbourhood healers and his nights working on the machine to make a few hundred tablets. His vision was to 'bring the traditional Indian science of Ayurveda to society in a contemporary form'. In a time when herbal products were regarded with scepticism, our founder's belief in the healing power of herbs was unwavering. He felt that if people were offered safe and effective herbal medicines, they would come to accept them as part of their healthcare routine. He believed that herbal medicines could and should be evaluated on the same quality and efficacy parameters as conventional medicine. This was possible through empirical research. Once scientific research proved that herbal products worked, even doctors could be won over. This was a big dream with big challenges. But he persevered on despite the obstacles. After four years of researching the herb Rauwolfia serpentina, Serpina, the world's first natural antihypertensive drug was launched in 1934

TABLE SHOWING AGE OF THE RESPONDENTS

S.NO	AGE	NO.OF RESPONDENTS	PERCENTAGE
1	Below 20	47	39.17
2	21-40	54	45
3	41-60	14	11.67
4	Above 60	5	4.17
	Total	120	100

(source: Primary)

INTERPERTATION

From the table show that 39.17 % of the respondents are below 20,45% of the respondents are 21-40, 11.67 of the respondents are 41-60 and 4.17% of

the respondents are above 60. Majority ,39.17% of the respondents are below 20

**TABLE SHOWING THE FAMILY INCOME OF THE RESPONDENTS**

S.NO	PARTICULARS	NO.OF RESPONDENTS	PERCENTAGES
1	Below Rs 15000	39	32.50
2	Rs 15000 – Rs 25000	47	39.17
3	Rs 25000 – Rs 40000	29	24.17
4	Above Rs 40000	5	4.17
	TOTAL	120	100

*(Source: primary data)***INTERPEFTATION**

The above table show that 32.50% of the respondents are below Rs 15000 ,39.17% of the respondents are Rs 15000- Rs 25000, 24.17% of the

respondents are Rs 25000-Rs 40000, 4.17 %of the respondents are above 40000.

Majority ,39.17% of the respondents are Rs 15000- Rs 25000.

TABLE SHOWING MARITAL STATUS OF THE RESPONDENTS

S.NO	PARTICULAR	NO.OF RESPONDENTS	PERCENTAGE
1	Married	29	24.17
2	Un married	91	75.83
	TOTAL	120	100

*(Sources: Primary data)***INTERPERTATION**

The above table shows that 24.17% of the respondents are married and 75.83% of the respondents are unmarried.

Majority,75.83% of the respondents are Unmarried1

FINDINGS FROM PERCENTAGES ANALYSIS

- Majority ,39.17% of the respondents are below 20.
- Majority, 39.17% of the respondents are Rs 15000 – Rs 25000.
- Majority, 75.17% of the respondents are unmarried.
- Majority, 29.17% of the respondents are UG or PG level.
- Majority, 37.50% of the respondents are home maker.
- Majority,77.50% of the respondents are nuclear family
- Majority,64.17% of the respondents are aware in beauty cream.
- Majority,51.67% of the respondents are like to buy a beauty cream in Himalaya.

- Majority, 45% of the respondents are friends.
- Majority, 39.17% of the respondents are using super market.
- Majority, 40.83% of the respondents are monthly cream using people.
- Majority ,41.67% of the respondents are Rs 100 – Rs 150.
- Majority ,40.83% of the respondents are 3 – 4 years.
- Majority ,43.33% of the respondents are moisteration.
- Majority ,25% of the respondents are agree.
- Majority, 83.33% of the respondents are not facing any problem

FINDING FROM LINKERT SCALE ANALYSIS

- Linkert scale value is 4.37 greater than the middle value(3). So the consumer are agree in the quality
- Linkert scale value is 4.15greater than the middle value(3). So the consumer are agree in the price.



- Linkert scale value is 3.69 greater than the middle value(3). So the consumer are agree in the brand name.
- Linkert scale value is 3.7 greater than the middle value(3). So the consumer are agree in the side effects.
- Linkert scale value is 4.15 greater than the middle value(3). So the consumer are agree in the availability.
- Linkert scale value is 3.39 greater than the middle value(3). So the consumer are agree in the Gifts.
- Linkert scale value is 2.4 greater than the middle value(3). So the consumer are agree in the discount.
- Linkert scale value is 3.2 greater than the middle value(3). So the consumer are agree in the quantity.

REFERENCES

1. *Abiji Bhandari, " Making loyalty pay", American marketing journal,31,Dec, 2000, p.22.*
2. *Bass Frank.M., the theory of stochastic preference and brand switching, journal of marketing research vol.11p.20*
3. *Deepall singh 2001 " consumer behaviour and banking retil product analysis", banking finance, may 2001.*
4. *Dr.N.Raja sekar, " the Indian journal of marketing" mar 2002*
5. *Prof.Dr.p.h. kulkarni ' ayurveda soundaryam towards beauty' s. chand\$ co, 20036.MR.Khalid " the effect of country of origin on consumer perceptions of cosmetic products and serives" the international conferences calcullat 2003*

RANK ANALYSIS

- ❖ Product gives moister have been ranked 1st by the respondents.

SUGGESTION

- With the help of analysis and interpretation it is found that majaority of the people know about the Himalaya female beauty cream product.
- Some of the respondents feel door delivery is the best promotional measures.So the company can concentrate by the above factor.
- The result indicated that people are satisfied with the Himalaya female beauty cream product.
- Also there are lots of scope in Himalaya female beauty cream product.
- They customer need a discount or gifts for Himalaya female beauty cream.

CONCLUSION

In the present scenario Himalaya beauty cream product are one of the very essential products for all walks of people. This reasarche study was conducted to increase our current understanding of Himalaya female beauty cream care market in general ana analysis consymer decision making in particular.



STUDY ABOUT BIOFUEL PRODUCTION FROM FISH WASTE AND ITS POTENTIAL IN KERALA

Soorya Narayan

Research Associate, International Centre for Technological Innovations

ABSTRACT

Kerala is blessed with a coastline of 590km and have a wide range of aquatic species in it. A large number of fish processing plants are operating in the state and their wastes are generally dumped into local water bodies degrading the quality of water. Fish wastes have an enormous potential to be a source of energy (biofuel) and also to be an animal feed. Total fish production in Kerala is about 5.44 lakh tonnes in 2019 of which approximately about one-third is the fish waste that is about 18,000 tons. From this amount of fish wastes about 90,655 liters of fish oil can be produced and finally 90,000 liters of biofuel is the approximate amount we can produce annually. And also due to high lipid content in fish wastes and low microbial content they are an excellent choice to be the feedstock of various animal feeds.

1. INTRODUCTION

1.1 Fish Wastes & Bio-Fuels

A large volume of fish wastes is produced daily in the Indian subcontinent. This abundant waste source could serve as an economic feedstock for bioenergy generation. Around 30-40 % of fish is consumed fresh whereas 60-70 % is being processed for human consumption and other purposes. However, not all parts of fish are eaten and substantial parts are discarded. The discarded fish parts include caudal fin, anal fin, pelvic fin, dorsal fin, operculum, overlapping scales, and eye. Therefore, the subcontinent regions worldwide have a vast potential for the generation of value-added products from fish wastes e.g. waste fish oil. In reality, however, the waste fish parts are usually discarded and considered to be of low utility and thus are found of limited applications. Since the fish markets are scattered all over the country, the waste parts are usually disposed of as solid waste with no proper application. Alternatively, these wastes could be channelized into local biofuel plants as an economic feedstock for high-quality biofuel production. Biofuels are globally known as a sustainable alternative fuel for petroleum-based diesel. The advantages delivered by blending biofuel with diesel are numerous including renewability, carbon neutrality, reduced emission of toxic pollutants, and better lubricity of the blended fuel. On the other hand, there are some disadvantages such as

comparatively higher emission of oxides of nitrogen; generally higher production cost, and less oxidation stability than diesel. Despite all these drawbacks, the advantages mentioned earlier are still attractive enough to guarantee the continued production and supply of biofuel to be used in compression ignition (CI) engines. (Yogesh *et.al.* 2014)

1.2 Fish Processing Industry in Kerala

Being surrounded by oceans, fishing has been one of the major occupations of people in Kerala. Conventional fishing technologies have evolved over years and nowadays fish processing industries are one of the major sources of income generation. But fish processing is not limited to a single step it must undergo several steps before the product is ready to be sold in the market. Fishes are caught from the deep sea and are sorted by size and species. This sorting is followed by the removal of heads, tails, scales, and entrails. After removing the fin from the remaining parts are washed thoroughly and are further processed for packing. The removed parts are considered fish waste. Most of the advanced fish processing units have their waste treatment plants but micro-processing plants are dumping the wastes to nearby water resources which ultimately results in water pollution.



1.3 SEAFOOD PROCESSING COMPANIES IN KERALA

There are several seafood processing companies in Kerala, in which a wide species of fishes are caught, processed, and sold. These are some of the companies in Kerala

- Indian Marine Industries, Kochi
- Penver Products Limited, Alappuzha
- Choice Trading Corporation Private Limited, Ernakulam
- Mangala Marine Exim India Private Limited, Ernakulam
- Armstrong Industries, Alappuzha
- International Creative Foods Limited, Kochi
- Amalgam Enterprises, Kochi
- Integrated Rubian Exports Limited, Alappuzha
- Malayalam Edibles India Limited, Kottayam
- Revieraa Marine Private Limited, Kochi
- Cochin Condiments Private Limited, Idukki
- Geo Sea Foods Private Limited, Kochi
- West Coast Refrigeration And Food Engineering Private Limited, Kochi
- Roshan Foods Private Limited, Kochi
- Wender S Foods Private Limited, Kollam
- Marine India Exports Private Limited, Kochi
- Trittee Seafood Exports Private Limited, Kochi
- Geo Seafoods, Kochi
- Veronica Marine Exports Private Limited, Kollam
- Gks Business Associates Private Limited, Alappuzha
- Ocean Wealth Exports, Alappuzha
- Uniroyal Marine Exports Limited, Kozhikode
- Geoaquatic Products Private Limited, Kochi

1.4 INDUSTRIAL PARKS IN KERALA

1) KINFRA SEAFOOD PARK AROOR

Kerala industrial infrastructure development cooperation aims at converging resources available to develop industrial growth in Kerala. The specialty of KINFRA is that it offers a single-window clearance facility, attractive incentives, and excellent expansion opportunities. KINFRA seafood park contains quality control labs pre-processing centers and effluent treatment plants. The quality control labs in KINFRA have high-efficiency types of equipment



2) KSIDC Mega Food Park

This mega food park primarily focuses on the seafood processing sector. They have grant assistance from the central government (Ministry of Food). Their main objective is to create a modern enabling infrastructure for setting up the food processing industry. The main components of KSIDC mega park are the central processing center, primary process center, and collection center. The central processing center contains an industrial shed, cold storage, freezer facility, debony room, Q&C, and food testing lab. Locations for primary processing centers are chosen based on the availability of raw material, and infrastructure. The activities done here are peeling, cleaning, sorting, and grading.



1.5 Fish Markets in Kerala

India is the second-largest fish producing nation in the world. Also, India ranks 2nd position in aquaculture. The state of Kerala is gifted with rich resources of marine and freshwater resources. These water bodies are inhabited by a wide variety of aquatic flora and fauna. Also, there are different ethnic groups in contact with fishing. Total fish production in Kerala was 5.44 lakh tonnes in which 3.88 lakh tonnes accounted for marine fish and 1.56 lakh tonnes by inland fish production. Out of Kerala's total population, about 31% of the state population is considered to be fish workers. Alappuzha is the district with the largest fish worker population followed by Trivandrum and Ernakulam. (THE NEW INDIAN EXPRESS 30th JUNE 2020)



2.0 RESEARCH OBJECTIVES

- To identify the easiest method to extract fish oil from fish waste
- To identify the simplest method to convert fish waste to biofuel
- To identify different ways to utilize crushed fish waste after extracting fish oil.

3. LITERATURE REVIEW

3.1 Study of Methods to Extract Fish oil from Fish waste

1) By using a mechanical expeller

The oil extraction is done mechanically with an oil expeller press. The expeller powered by a 5hp electric motor was set into operation. The interrupted helical screw drum conveyed, crushed, squeezed, and pressed the fishes to extract the oil. The oil and water phases (containing water-soluble proteins as well) are separated from the solid phase (press cake). The fluid extracted and the press cake was collected and weighed separately. Clarification of oil was done to separate the oil from its entrained impurities. The fluid extracted out of the press is a mixture of fish oil, water, cell debris, and non-oily solids. The fluid is allowed to stand undisturbed to settle by gravity so that the oil, being lighter than water, will separate and rise to the top. The clear oil is obtained and separated. (Kwasi Poku 2002)

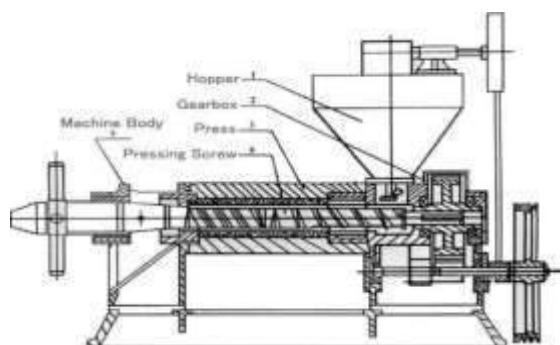

2) Microwave-assisted extraction method

Microwave-assisted extraction was carried out using distilled water and hexane/isopropanol mixture with ratio 3:2 (v/v) as extraction solvents. 2 g of fish waste was mixed with 1 g sodium sulphate and soaked in 42 ml of the extraction solvent. Then the mixture was subjected to microwave power at 800 Watt. At this power, the sample was irradiated for 2, 3, 5, 7, and 10 min when using water as a solvent and 1-4 mins when using the organic solvent. After that, the mixture was filtered using filter

paper. 5 ml hexane was added to separate the filtrate mixture. The upper layer was taken and dried. After that, lipid weight was measured. In Hara and Radin method distilled water and hexane: isopropanol with ratio 3:2 (v/v) were employed as extraction solvents. 2 g of sample was added to 36 ml solvent and homogenize for 30 seconds. After homogenization, the mixture was filtered into a round bottom flask. The residual on the filter paper was rinsed twice with an additional 10 ml hexane which was also filtered into the same round bottom flask. 24 ml aqueous sodium sulphate was added to the filtrate. The aqueous sodium sulphate was prepared by mixing 30 ml water and 1 g sodium sulphate. After the addition of the aqueous sodium sulphate solution, two layers were formed. The lipids were in the upper layer, pipetted out, and dried to obtain the lipid weight. (M A Rahimi *et al.* 2017)

3) An experimental setup using a pressure cooker.

This is a conventional method that uses the pressure built inside a pressure cooker to pressurize and expel the oil content from the fish wastes. This method is generally cheap, easier, and not very time-consuming. But the residue after extracting the oil will remain solid and the oil will be in a mixed state with the water inside the pressure cooker. The water-oil mixture can be separated by using a separating funnel.

3.2 Study of the process of converting fish oil to biofuel.

1) Transesterification

Transesterification is a chemical reaction used for the conversion of triglycerides (fats) contained in oils, (Feedstocks) into usable biodiesel. Biofuel produced by the process of transesterification has a much lower viscosity, making it capable of replacing petroleum diesel in diesel engines. However, during the transesterification reaction, a certain amount of water is produced as a byproduct which causes ester hydrolysis along with soap, as a result, it becomes hard to purify products by separating the catalyst. (Hideki *et al.* 2001)

a) Transesterification using acid catalyst

Homogeneous Lewis acid (H₂SO₄) and carboxylates (PbCH₃COOH) have been used as catalysts for biofuel production from oil even if it has a high. Several heterogeneous acids were also used (ion-exchange resin, metal oxides, heteropolyacids, etc). However, three main drawbacks reported for the use of carboxylates catalyst are its work under high



temperature and pressure ($T > 190^{\circ}\text{C}$, $P > 20$ bar); purification of the product is costly and not economical for industrial application. Supported sodium and potassium on larger surface area zeolite and alumina had given up to 85% conversion of fame which is still lower as compared to a solid base catalyst. (Sadia *et al.* 2017)

b) Base catalyzed transesterification

Presently, various alkali-based catalysts have been utilized as homogeneous and heterogeneous transesterification. Base catalyzed transesterification is substantially less time consuming than acid-catalyzed transesterification and it is regularly used for commercial purposes. Numerous solid alkali base metal oxides and their substrate have been used for homogeneous catalyzed transesterification. The benefit of alkali base catalysis requires a little amount in catalysis NaOH or KOH are generally utilized as catalysts for transesterification of triglycerides at atmospheric pressure and temperature. Evacuation of these catalysts is troublesome and it adds additional cost to the final product. It was reported in many researches that alkaline metal is less expensive than metal alkoxides, however, the action of alkaline metal alkoxides (CH_3ONa for the methanolysis) is more dynamic as a catalyst, then soluble metal hydroxides (KOH and NaOH since the previous) give a high yield in a short time than the last mentioned. (L.D. Metacalfé *et al.* 1981)

3.3 Methods by which fish waste can be used after oil expulsion

a) Fish waste as animal feed.

The use of fish waste as animal feed is an area of interest for many people because of environmental and public benefits. It also reduces the cost of synthesized animal feed. Pellets are prepared from heads, skeletons, tails, and intestines. The test results suggested that the food items made from fish waste contain low microbial content and good lipid source.

b) Biogas production

There is a high potential for anaerobic digestion of fish wastes. An experiment was conducted to find out the ability of fish waste to produce biogas. 4 plastic digestors were taken and provided the mixture of cow dung and fish waste in a series of ratios ranging from 1:0 to 1:1.5. The highest yield 2l/kg was obtained when cow dung and fish waste were mixed in the ratio 1:1.2. when the fish waste alone was used the yield was 150ml/kg and it took about

10 days to start biogas preparation. (Bodius Salam *et al.* 2009)

4. RESEARCH ANALYSIS

4.1 Easiest method for producing fish oil from fish waste

The method was nothing but conventional extraction using a pressure cooker. This method saves a lot of time and also a cost-effective method to follow. The fish waste was initially cleaned thoroughly and water was added to such a level that the fish waste sinks in it. After pressurizing it for about 15 minutes. A layer of oil and water mixture can be obtained. These mixtures can be separated using a separating funnel. Also, the main advantage of this method is that it requires less space, time, and resources. About 10ml fish oil was extracted initially as a test procedure and finally, we extracted about 1L of fish oil by this method. Considering a single fish 60% of it is consumable and the rest is considered as

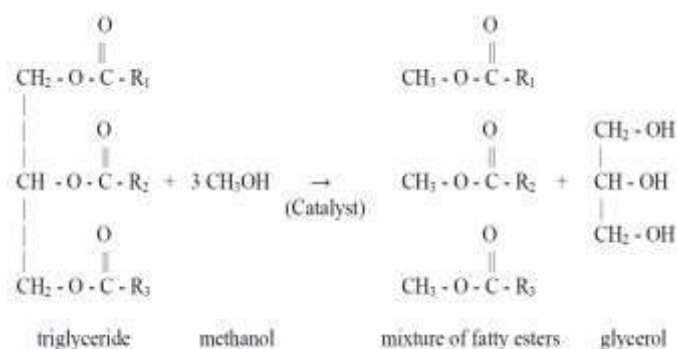

wastes. These include the head, scales, fins, etc.

4.2 Simplest method to convert fish oil to biofuel.

The simplest way to convert fish oil to biofuels transesterification, using the base as a catalyst. Presently, various alkali-based catalysts have been utilized as homogeneous and heterogeneous transesterification. Base catalyzed transesterification is substantially less time consuming than acid-catalyzed transesterification and it is regularly used for commercial purposes. Numerous solid alkali base metal oxides and their substrate have been used for homogeneous catalyzed transesterification. The benefit of alkali base catalysis requires a little amount in catalysis. Esters in the presence of a base such as an alcoholate anion form an anionic intermediate which can dissolve back to the original ester or form the new ester. The most useful basic transesterified agents are sodium or potassium methoxide in anhydrous methanol. The main



advantage of base-catalyzed transesterification over acid one is that it is fast and can be conducted at low temperatures(303-308K) and pressure(0.1Mpa). By the transesterification of 1L of fish oil, 0.9 L of biofuel can be obtained.

4.3 Usage of oil expelled fish waste.

Since the fish waste contains high lipid content and low microbial content it is very advantageous to use the same as animal feed. The fish wastes contain high lipid content due to unsaturated fatty acids. Also since fish waste contains liver glycogen contents increased hematocrit values and faster growth rates were observed in animals. So as a result quality food can be bought at a very low price as it is primarily a waste product of oil extraction units.

5. CONCLUSION

Energy is an essential factor in improvising the life quality of individuals. Fish waste which was considered a solid waste can be utilized for multiple benefits. They have a high potential to provide energy in the form of biodiesel. Thus lowering emissions from diesel engines. They

can also be used to produce animal feed which has high lipid and protein contents. Biofuel can be produced from fish oil by the process of transesterification using a base catalyst. The easiest method to derive fish oil from fish waste is treating it in a pressure cooker under ambient temperature. The mixture of oil and water thus obtained can be simply separated through a separating funnel. 0.9l of biodiesel was obtained from 1 l of fish oil and 10ml of fish oil was obtained from 1 kg of fish waste. Since Kerala produces 5.44 lakh tons of fishes annually about 18 thousand tons of waste can be obtained from this. On this scale, about 90,655 liters of fish oil can be produced and about 90,000 liters of biofuel can be produced. This also suggests the possibility of a cooperative society to collect the fish wastes and converting them to biofuel and animal food, thus creating employment opportunities and solving the problem of waste management.

6. REFERENCES

1. Kwasi Poku, 2003, *Small-Scale Palm Oil Processing in Africa, Food and Agriculture Organization of United Nation Rome*
2. Yogesh C. Sharma Bhaskar Singh & Devarapaga Madhu, 2014, 'Fast Synthesis of High-Quality Biodiesel from 'Waste Fish Oil' by Single Step Transesterification', *Biofuel Research Journal* 3 (2014) 78-80, viewed on 18 September 2020, from https://www.biofueljournal.com/article_6142_3dfa1cde451951df9e669677b90070bf.html.
3. Sadia Nasreen, Muhammad Nafees, Liaqat Ali Qureshi, Muhammad Shahbaz Asad, Ali Sadiq Syed Danial Ali., 2017, 'Review of Catalytic Transesterification Methods for Biodiesel Production', *Journal of Bio Fuel*, (abstract), viewed on 19 September 2020, from <https://www.intechopen.com/books/biofuels-state-of-development/review-of-catalytic-transesterification-methods-for-biodiesel-production>
4. 'TN grabs the first position in fish production, Kerala in the third spot with 15.4% decline', *THE NEW INDIAN EXPRESS* 30th June 2020, p. 8.
5. M A Rahimi, Saleem Ethaib, Siti Mazlina Mustapa Kamal., 2017, 'Microwave-assisted extraction of lipid from fish waste', *IOP Conference Series Materials Science and Engineering* 206(1):012096, viewed on 22nd October 2020, from https://www.researchgate.net/publication/317798187_Microwave-assisted_extraction_of_lipid_from_fish_waste
6. Hideki Fukuda, Akihiko Kondo, Hideo Noda., 2001, 'Biodiesel fuel production by transesterification of oils', *Journals of Bioscience and Bioengineering*, viewed on 22nd October 2020, from <https://www.sciencedirect.com/science/article/abs/pii/S1389172301802887#!>
7. L.D. Metcalffe., 1981, 'Rapid Preparation of Fatty Acid Methyl Esters Using Organic Base-Catalyzed Transesterification', *Journal of Chromatographic Science*, Volume 19, viewed on 26th September 2020, from <https://academic.oup.com/chromsci/article-abstract/19/10/530/329755>
8. Bodius Salam, Md Rabul Islam Sarter., 2009, 'Biogas from anaerobic digestion from fish waste'. *Intl. Conf. of Mechanical Engineering (ICME 2009)*, Dhaka, Bangladesh, December 26-28, 2009.



A STUDY ON CUSTOMER'S SATISFACTION TOWARDS AAVIN MILK WITH SPECIAL REFERENCE TO TIRUPUR CITY

B. Arun Nithish

*Student of III B.Com (PA), Department of Commerce with Professional Accounting,
Dr. N. G. P Arts and Science College, Coimbatore*

Mrs. P. Dhanya

*Assistant Professor, Department of Commerce with Professional Accounting,
Dr. N. G. P Arts and Science College, Coimbatore*

ABSTRACT

Milk is a vital part of the global food system and also vital for human growth and development. It maintains our body and protects us from various diseases. The economic outlook and the process of absorbing nutrients from food and processing them in the body in order to grow healthy, benefits to a large proportion of the world's population. In India, dairy and dairy products are needed to an unspecified very large number of people in the village. It has become one of the sources of income for the Indian rural families in addition to the traditional agricultural products. The study was conducted in Tiupur city. A sample size of 120 respondents. Quality has been ranked 1 according to the customers satisfaction.

KEY WORDS-*Customers satisfaction, Quality, Taste and preference, Packaged milk.*

INTRODUCTION

India is the world's largest milk producer and all set to become the world's largest food factory. India's dairy industry is considered as one of the most successful development. Dairy cooperatives account for the major share processed liquid milk marketed in the India. Milk is an essential item used by the people as vegetarian diet more consumption of milk depend not only on its factor but also on the availability of children and also by practice of taking coffee, tea, etc.

In this competitive world, various brands of packet milks are available. Packet milk is preferred for its merits economy hygiene, quality, availability and so on. Packet milk is available to consumers at any time wherever it is needed. Milk composition has a dynamic nature, and the composition varies with stage of

lactation, age, breed, nutrition, and energy balance and health status of the udder. Colostrums differ considerably to milk; the most significant difference is the concentration of milk protein that may be about the double in colostrums compared to later in lactation.

Dairy and dairy products provide livelihood to millions of homes in Indian villages. They supply the quality of milk and milk products to people of both urban and rural areas. Dairying has become an essential secondary source of income for millions of rural families.

STATEMENT OF THE PROBLEM

In the busy world of ours, each human being is running like a machine. It could be the influence of the variable price brand image, quality of the product and



regularity of service. The success of the milk product depends not only on the price but also the customer satisfaction towards their product. It's necessary to know the customer satisfaction towards packaged milk of its availability, acceptance and affordability. Since the time a person gets up from his bed till he goes to sleep, milk plays a key role.

SCOPE OF THE STUDY

The study helps to know about the customers opinion on buying Aavin milk in Tirupur city. It also help us to know the changing needs of customers and to find out the factors which influence the level of satisfaction of customers. With the study we can give suggestions regarding customer satisfaction and to retain the existing customers as well as the attracting new customers to buy the product.

OBJECTIVES OF THE STUDY

1. To identify the satisfaction level of customer's towards Aavin milk.
2. To study the customer's buying behavior towards Aavin milk.
3. To determine the major factors influencing the customers to buy Aavin milk.

RESEARCH METHODOLOGY

Research methodology is the systematic way to solve research problem, it may be understood as a science of studying how research done systematically. This includes geographical area covered, method of data collection.

DATA COLLECTION

Both primary and secondary data were used.

PRIMARY DATA

This data acts as the main source and was collected through questionnaire.

SECONDARY DATA

This data have been collected form the following sources journal, article, websites, books, etc....

SAMPLE DESIGN

Sample is the fraction of the population, sampling is technique or a method of selection of samples. The researcher in carrying out this

research adopted the most appropriate sampling technique for research that is convenient sampling

SAMPLE SIZE

The sample size is 120 respondent.

AREA OF THE STUDY

The study was carried out in Aavin milk, Tirupur city.

TOOLS FOR ANALYSIS

- Simple percentage analysis
- Ranking correlation.

LIMITATION OF THE STUDY

1. The sample respondents taken for the study is limited.
2. Due to lack of time, the study has been destructed to Tirupur city only.
3. The result is completely relies upon the collected data which was presented by the respondent.

REVIEW OF LITERATURE

Karthikeyan .P (2019), "Consumer satisfaction towards Aavin Milk products" It reveals that the majority of the respondent made their purchases through the agent of the unions, Reasonable price, Good quality, adequate quality, convenient packing and correct weightiest are found to be the prominent for preferring for Aavin milk products. Proper education and training should be given to milk producers and seller were the main suggestions given by the respondents.

Hanishkanthraja. G, Subburaj. B (2018), "Consumer preference towards Aavin brand" The consumers change their attitude frequently on the basis of new trend and fashion and availability of Good quality product. Milk producers must meet consumers' demand for milk on the basis of Maintenance of good quality and purchase return policy, creation of awareness of Aavin's product should on timely basis be concentrated more in order to meet out the global competitive market.

Dhanya. K, Venkatesa Planichamy. N (2018), "A Study on Customer buying behavior towards Aroma Milk products" This product has a good reputation among the customers, so it can be extended supplying products towards the customers demand for and availability in markets must maintained for the consumer to say in the same Aroma Brand. Industry can target that segment and use it as an opportunity to



expand their sales by satisfying those consumers also by retaining the existing consumers.

data have been analyzed using the following statistical tools.

- ▲ Simple percentage analysis.
- ▲ Ranking correlation.

DATA ANALYSIS AND INTERPRETATION

This chapter deals with the analysis and interpretation of the study “A study on customer satisfaction towards Aavin milk with special reference to Tirupur city” based on the data’s are collected. The collected data have been classified and tabulated. The

Simple Percentage Analysis

Simple percentage analysis is carried out for most of the questions. The analysis describes the classification of the respondents falling under each category. The percentage analysis is used for standardization and comparison.

FORMULA

$$\text{Percentage} = \frac{\text{Number of respondent}}{\text{Total respondent}} \times 100$$

**TABLE 4.1.1
GENDER OF THE RESPONDENT**

S.NO	GENDER	NO.OF. RECONDENTS	PERCENTAGE (%)
1.	Male	72	60
2.	Female	48	40
	TOTAL	120	100

(Sources: Primary data)

INTERPRETATION

From the above table it is inferred that 60% of the respondent belongs to male and 40% of the respondent belong to female.

Hence, most (60%) of the respondent belongs to Male.

there is need for a measure of correlation that is need for correlation that involves no assumption above the parameter of population.

It is possible to avoid making any assumptions above the population being studied by ranking the observation according to size and basing the calculation on the ranks rather than upon the original observations. It does not matter which may the items are ranked, item number one may be the largest or it may be smallest using ranks rather than actual observation gives the coefficient rank correlation.

RANKING CORRELATION

The Karl Pearson’s method is based on the assumption that the population being studied is normal or when the shape of the distribution is not known,

FORMULA

$$\frac{R = 1 - 6\sum D^2}{N(N^2-1)} \quad \text{(OR)} \quad \frac{1 - 6\sum D^2}{N^3 - N}$$

**RANKING CORRELATION**

FACTORS	1	2	3	4	5	TOTAL SCORE	FINAL RANK
QUALITY	40(5) 200	28(4) 112	34(3) 102	9(2) 18	9(1) 9	441	1
TASTE	12(5) 60	43(4) 172	49(3) 147	14(2) 28	2(1) 2	409	2
PACKAGING	7(5) 35	40(4) 160	52(3) 156	15(2) 30	6(1) 6	387	6
CONVENIENCE	10(5) 50	39(4) 156	41(3) 123	24(2) 48	6(1) 6	383	7
SPECIAL OFFERS	12(5) 60	43(4) 172	39(3) 117	15(2) 30	11(1) 11	390	5
QUANTITY	13(5) 65	22(4) 88	58(3) 174	16(2) 32	11(1) 11	370	9
FRESHNESS	12(5) 60	31(4) 124	50(3) 150	19(2) 38	8(1) 8	380	8
HOME DELIVERY	20(5) 100	32(4) 128	38(3) 114	22(2) 44	8(1) 8	394	4
PRICE	16(5) 80	34(4) 136	50(3) 150	13(2) 26	7(1) 7	399	3

(Sources: Primary data)

INTERPRETATION

The above table shows that the quality is ranked 1, Taste is ranked 2, Price is ranked 3, home delivery is ranked 4, special offer is ranked 5, packing is ranked 6, convenience is ranked 7, freshness is ranked 8, quantity is ranked 9.

Quality is ranked 1 based on the respondents ranking towards the performance of Aavin milk.

FINDING OF THE STUDY**FINDING OF SIMPLE PERCENTAGE ANALYSIS**

- It is found that majority, 60% of respondents are Male.
- It is found that majority, 55% of respondents are between 21-40 years.
- It is found that majority, 69% of the respondents are under graduates.
- It is found that majority, 68% of the respondents are nuclear.
- It is found that majority, 43% of the respondents are business.
- It is found that majority, 74% of the respondents are unmarried.
- It is found that majority, 39% of the respondents of family income earned by 3 and above members.

- It is found that majority, 46% of the respondents are earning members of the family is 2(Two)
- It is found that majority, 38% of the respondents are earning 21,000-30,000 monthly income
- It is found that majority, 50% of the respondents are consuming 1 liters-2 liters.
- It is found that majority, 42% of the respondents are using aavin milk for 2 years-4 years.
- It is found that majority, 42% of the respondents are offered from their friends and relatives.
- It is found that majority, 33% of the respondents are buying form Aavin preferred outlets.
- It is found that majority, 37% of the respondents are influencing by the Quality.
- It is found that majority, 52% of the respondents are preferring to Green.
- It is found that majority, 44% of the respondents are promoting sales by extra quality.
- It is found that majority, 88% of the respondents are accepting that the aavin milk is hygienic than other products.



FINDINGS OF RANKING CORRELATION

- Quality has been ranked 1 according to the customer's satisfaction.
- Taste has been ranked 2 according to the customer's satisfaction.

SUGGESTIONS

- The Quantity of aavin milk in 100ml and 200ml packets can be introduced .
- The door delivery system of Aavin milk in the urban and rural areas can be introduced.
- The customers expecting that the Quantity of Aavin milk is to be available same in all times.
- Some of the respondents feels that the company has to improve their Advertisement and give awareness about Aavin milk.
- To improve thickness of Aavin milk which was not sufficient with the present thickness of milk.

CONCLUSION

Aavin milk has a good reputation among the customer so it can be extended to supply rural also. In this modern competitive world, customer mainly prefers taste and new style of packages. A key factor for the success of branded milk is mainly concerned with high quality. Though Aavin milk is enjoying good position in milk industry, in order to strengthen their position ,they can try to reduce their price. They can introduce 100ml and 200ml packaged milk to meet weaker section and they can go for sales promotion activities. The Researcher concluded that the respondents are highly satisfied with Aavin milk.

REFERENCE

1. Karthikeyan. P (2019), "**Consumer satisfaction towards Aavin Milk products**" *International Journal of Marketing Research Review* Volume 7(2).
2. Hanishkanthraja. G, Subburaj .B (2018), "**Consumer preference towards Aavin brand**" *International Journal of Commerce and Management Research* Volume 4(1).
3. Dhanya. K, Venkatesa Palanichamy. N (2018), "**A Study on Customer buying behavior towards Aroma Milk products**" *International Journal of advances in Agriculture Science and Technology* Volume 5(7).



A STUDY ON CONSUMER SATISFACTION TOWARDS BANKING SERVICE PROVIDED BY SBI WITH SPECIAL REFERENCE TO ANNUR BRANCH

Ranjitha. C

*Student of III B.Com (PA), Department of Commerce with Professional Accounting,
Dr. N.G.P Arts and Science College (Autonomous), Coimbatore*

Dr. D. Sivasakthi

*Associate Professor, Department of Commerce with Professional Accounting (Autonomous),
Dr. N.G.P Arts and Science College, Coimbatore*

ABSTRACT

The purpose of this research article is to evaluate the customers satisfaction towards the banking services rendered by the SBI in Annur Branch. The author conducted a literature search on banking services of SBI interviewing of its 120 customers and thoroughly scrutinized how it caters to the needs of the inhabitants of Annur Branch. The study also focused on various factors that determine the customer satisfaction like employees behaviour, banking services, banking performance, infra-structure facility, loan oriented service and other value added services. Analysis was made by using various tools like percentage analysis, Chi-square test and charts. The results showed that there is a significant relationship between the variable of customer satisfaction and banking services of the SBI and the customers have a medium level of satisfaction. The SBI could consider the research's in order to alleviate its reputation and customer satisfaction.

KEY WORDS: *Customer satisfaction, Banking services and services of SBI.*

INTRODUCTION

Customer satisfaction is measured at the individual level, but it is almost always reported at an aggregate level. It can be and often is, measured along various dimensions. A hotel, for example, might ask customer to rate their experience with in front desk and check-in-service, with the room, with the amenities in the room, with the restaurants, and so on.

Customer satisfaction a term frequently used in marketing, is a measure of how products and services supplied by a company meet or surpass customer expectation. Customer satisfaction is defined as "the number of customers, or a percentage of total customer, whose reported experience with a firm, its products, or its service exceeds specified satisfaction goals". In a survey of nearly 200 senior marketing managers, 71 percent responded that they found a

customer satisfaction metric very useful in managing and monitoring their business. "Customer satisfaction provides a leading indicator of customer purchase intentions and loyalty". Customer satisfaction data are among the frequently collected indicators of market perceptions.

Customer service is the provision of service to customer before, during and after a customer service is a service of activities designed to enhance the level of customer satisfaction—that is, the feeling that product or service has met the customer expectations".

STATEMENT OF THE PROBLEM

In the banking field a unique relationship exists between the customers and the banks. Customer satisfaction can be adopted in the banks to improve the



quality of service offered to attract their customer. So there is a need for this study to use customer satisfaction as a helping tool to evaluate the quality of services and facilities given to their customers.

SCOPE OF THE STUDY

The study is conducted to know the customer satisfaction of SBI in Annur Branch. It also reveals the quality of various service offered.

*It helps to know the effective relationship between the SBI and its customers.

*It measure various attractive service offered by the SBI and its customers.

*It helps to know the facilities available in the SBI Bank.

OBJECTIVES OF THE STUDY

- To assess the level of customer satisfaction on the quality of service provided by the SBI Bank in Annur Branch.
- To study the usage level of facilities and services that attract their customers of SBI Bank in Annur Branch.
- To evaluate the satisfaction level of the customers.

RESEARCH METHODOLOGY

This study has carried out of Annur Branch only.

SAMPLE DESIGN

Sample method:

Sampling method used in the study is "Convenient sampling" method.

Sample Size:

Population is infinite so the sample selected for the study is 120 respondents.

TOOLS FOR ANALYSIS

- ✓ Simple percentage analysis.
- ✓ Likert scale analysis.

LIMITATIONS OF THE STUDY

- Findings of the study may be influenced by personal of the respondents.
- Unwillingness of some respondents to provide information is another limitation.

FORMULA

$$\text{PERCENTAGE} = \frac{\text{Number of Respondents}}{\text{Total number of respondents}} \times 100$$

REVIEW OF LITERATURE

Dr.K.Mary. (2018) the study entitled, "CUSTOMER SATISFACTION ON INTERNET BANK SERVICES OF STATE BANK OF INDIA IN THOOTHUKUDI". In their study started that internet banking is regarded as a delivery channel, with the help of internet banking the customer has an access to number of service just at the click of a mouse.

Dr.M.E.Dodderaju(2017) the study entitled, "CUSTOMER SATISFACTION TOWARDS BANKING SERVICE -A STUDY OF REWARI DISTRICT." Observed that there is significance difference among the respondents according to their income level and level of the satisfaction whereas, there is a lack of customer's relationship and aggressive marketing in public bank as compared to private sector bank.

K.R.Sakthi Devi (2016) the study entitled "A STUDY OF CUSTOMER SATISFACTION TOWARDS SERVICE PROVIDED BY STATE BANK OF INDIA _ WITH SPECIAL REFERENCE TO ERODE . Customer satisfaction is an important because it provides markets and business owners with a metric that they can use to manage and improve their business.

DATA ANALYSIS AND INTERPRETATION

The data collected from the samples have systematically applied and presented in the following pages. They were also arranged in such away that, a detailed analysis can be made so as to present suitable interpretation for the same. The data have been analyzed using the following satisfaction tools.

- 4.1 Simple percentage analysis
- 4.2 Likert scale analysis.

SIMPLE PERCENTAGE ANALYSIS

The Percentage analysis is mainly employed to find the distribution of different categories of respondents. As the value are expressed in percentage it facilities comparison and standardization. This analysis describes the classification of the respondents failing under each category.



Table No: 1
Table showing GENDER of the respondents

S.NO	PARTICULARS	NO.OF RESPONDENTS	PERCENTAGE
1	MALE	65	54.2
2	FEMALE	55	45.8
TOTAL		120	100

(Source: Primary Data)

INTERPRETATION

It is revealed that 54.2% of the respondents are Male and the 45.8% of the respondents are Female. **Majority 54.2% of the respondents are Male.**

LIKERT SCALE ANALYSIS

A Likert scale analysis is a method of meaning attitude. Ordinal scale of responses to a question or statement. Ordered in hierarchical sequence from strongly negative to strongly positive. Used mainly in behavioural science, in likert's methods a person's

attitude is measured by combining (adding or averaging) their responses all items.

FORMULA

LIKERT SCALE = $\frac{\sum(FX)}{\text{NUMBER OF RESPONDENTS}}$

F=NO.OF RESPONDENTS

X=LIKERT SCALE VALUE

(FX)=TOTAL SCORE

MID VALUE

Mid-Value indicates the middle most value of the likert scale

Table No: 2
Table showing BANKING SERVICES of respondents

S.NO	FACTORS	NO. OF THE RESPONDENTS(F)	LIKERT SCALE VALUE(X)	TOTAL(FX)
1	Highly satisfied	31	4	124
2	Satisfied	75	3	225
3	Neutral	12	2	24
4	Not satisfied	2	1	2

(Source: Primary Data)

$$\begin{aligned} \text{Likert scale} &= \frac{\sum(FX)}{\text{total no. of respondents}} \\ &= \frac{375}{120} \\ &= 3.125 \end{aligned}$$

INTERPRETATION: It is revealed that 25.83% of the respondents are Highly satisfied and the 62.50% of the respondent of satisfied and the 10.00% of the respondents are neutral and the 1.67% of the respondents of Not satisfied.

FINDINGS

SIMPLE PERCENTAGE ANALYSIS

- Majority 54.2% of the respondents are Male.

- Majority 70.8% of the respondents are 18-27years.
- Majority 71.8% of the respondents are Single.
- Majority 34.2% of the respondents are Private employee.
- Majority 44.17% of the respondents are upto Rs.2,50,000.
- Majority 64.17% of the respondents are saving account.



- Majority 68.33% of the respondents are saving account.
- Majority 12.50% of the respondents are others.
- Majority 53.33% of the respondents are 2 years to 4 years.
- Majority 78.33% of the respondents are yes.
- Majority 39.17% of the respondents are wide branch network.
- Majority 31.67% of the respondents are to transfer.
- Majority 57.50% of the respondents are good.

ISSN (Online) :2454-6119,Pg No.112-115. Volume II,Issue I ,2016.

LIKERT SCALE ANALYSIS

- ❖ Majority 373.667% of the respondents are satisfied.
- ❖ Majority ,2.90833% of the respondents are satisfied.

SUGGESTIONS

- ❖ Banks may carry out some awareness program on internet facility provided them to the customer and other general public.
- ❖ Banks may ensure to protect the date and maintain the privacy of the customer using internet banking.
- ❖ Separate may be opened by the banks to resolve to the problem faced by the customer in using internet banking.

CONCLUSION

Most of the respondents satisfied with the services provided by the bank like deposit Services,ATM services,Fund transfer, online banking, card services and loan. According to gender female respondents are more satisfied with card services and loan than the male respondents,most of the respondents not aware about online banking services. According to different age group below 30 year age group respondents are more satisfied about the Services provide in bank.

REFERENCE

1. *Dr.K.Mary,(2018) " Customer satisfaction on internet bank services of state bank of india in Thoothukudi". volume 3, Issue 4,Pg No.77-90. April 2018 and ISSN (Online)2456-1304.*
2. *Dr.M.E.Dodderaju,(2017) "Customer satisfaction towards banking services- a study of rewari district." Impact factors :6.725, Pg No.1-18 ISSN (Online):2455 – 5428 volume 2,Issue 2,2017.*
3. *Dr.K.R.Sakthi Devi,(2016) "a study on customer satisfaction towards service provided by state bank of india – with special reference to erode district."*



A STUDY OF FACTORS AFFECTING IMPULSE BUYING BEHAVIOURS AND SPECIAL REFERENCES OF PAZHAMUDIR NILAYAM IN COIMBATORE

Ms. M. Kowsalya

*III B.Com (PA) Student, Department of commerce with Professional Accounting,
Dr. N.G.P. Arts and Science College, Coimbatore*

Dr.K. Vanaja

*Professor / HOD, Department of commerce with Professional Accounting,
Dr. N.G.P. Arts and Science College, Coimbatore*

INTRODUCTION

- Consumer buying behaviour refers to the buying behaviour of the ultimate customers. Consumer behaviours has been always of great interest to marketers.
- A consumer buying behaviours is influenced by social, cultural, personal and psychological factors. Consumer behaviors refers to the selection, and purchases and consumptions of goods and services for the satisfaction of their wants.
- The main objectives of understanding in store buying behaviour and identifying reasons for impulse purchase is to bring in more revenue and minimize fixed cost of retailing.
- An impulse purchases or impulse buying is an unplanned decision to buy a product or services, made just before a purchase.

SCOPE OF THE STUDY

- This study is conducted to know about why customers prefers their products and there satisfaction.
- This study will help the researches the understand about the customers opinion on price, quality, quantity, and availability, which could be helpful for their satisfaction, for the further improvement in their product.
- This study helps the researches to know whether the customers are satisfied with their

products. This shows the purchase level of the products.

STATEMENT OF THE PROBLEMS

Impulse buying disrupts the normal decision-making models in consumer's brains. The logical sequence of the consumer's actions is replaced with an irrational moment of self-gratification. Impulse items appeal to the emotional side of consumers. Some items bought on impulse are not considered functional or necessary in the consumer's lives. Preventing impulse involves techniques such as setting budgets before shopping and taking time out before the purchases is made. Several researches have been conducted worldwide where it is observed that impulsive buying is prevalent in retail store and supermarket.

RESEARCH METHODOLOGY

Research Design : Descriptive Research Design.

Area of the Study : Coimbatore.

Sample Size : 120

Sources of Data : Both primary and secondary data.

Sampling Technique : Convenience Sampling
Technique. Proposed Tools:

- Percentage analysis
- likert scale analysis
- Ranking analysis.



OBJECTIVES OF THE STUDY

- To determine the major factors influencing the buying decision of the customers.
- To know customers opinion about Kovai pazhamudhir niliyam
- To analyses the level of satisfaction towards on Kovai pazhamudhir niliyam.
- To find out problems faced by the customers

LIMITATION OF THE STUDY

- The study is focused on only customers based
- The researcher is focused only limited impulse buying product.
- The data collected only from customers attitude.

REVIEW OF LITERATURE

William applebaum (1951) , in the study, consumer behavior in retail stores commonly deals with the identification customer and their buying behavior factors. This article is supposed to stimulate folks that can gain the maximum from such studies to take benefits of the opportunities for gaining knowledge of extra about purchaser behaviour with in market place. Nisha athore., "A studying customer behavior in retail stores in Chennai", (journal of Marketing), ISSN:0022-2429, online ISSN: 1547-7185

FINDINGS

SIMPLE PERCENTAGE ANALYSIS

- Majority (61.67%) of the respondents were male
- Majority (39.17%) of the respondents were above 30-40 years
- Majority (35.83%) of the respondents were Govt employees
- Majority (26.67%) of the respondents were school level
- Majority (29.17%) of the respondents are Rs.1,00,000-Rs.2,00,000
- Majority (56.67%) of the respondents are unmarried
- Majority (39.17%) of the respondents are 2-6 members
- Majority (39.17%) of the respondents are Monthly twices
- Majority (34.17%) of the respondents are sometimes daily.
- Majority (34.17%) of the respondents are fruits.

- Majority (32.50%) of the respondents are salesman explanation.
- Majority (33.33%) of the respondents are occasionally
- Majority (33.33%) of the respondents are occasional
- Majority (29.17%) of the respondents are Highly satisfied
- Majority (41.67%) of the respondents are satisfied
- Majority (40.00%) of the respondents are satisfied
- Majority (30.00%) of the respondents are below 500

LIKERT SCALE ANALYSIS

Likert scale value is 3.29 greater than the middle value(3), so the consumers are agree in the less worried with the price of product.

Likert scale value is 4 greater than the middle value(4), so the consumers are agree in the buy the product if you can get free product.

Likert scale value is 4.19 greater than the middle value(4), so the consumers are agree in the availability of money affect your impulse buying behaviours.

Likert scale value is 4.18 greater than the middle value(4), so the consumers are agree in the promotional schemes affect your choices.

Likert scale value is 3.70 greater than the middle value(3), so the consumers are agree in the satisfied with the product which you buy without any plan.

Likert scale value is 3.47 greater than the middle value(3), so the consumers are agree in the usually find great pleasure in shopping

RANK ANALYSIS

If resulted that taste is in rank 1 and it is influences the respondents to take decision money back offers.

SUGGESTIONS

- Innovative loyalty programs is to be conceived by each retail group and introduced as early or possible in order to reward the regular customers.
- The store has put in to more efforts in making the advertisement ,media, an effective source of information in reaching the customers at large.
- Efforts should be made to reduce the price of certain products like new fruits, free products, children's toys etc, to attract the customers.



- Steps to be taken to provide better facilities to customers like parking areas , and improve the price discounts, and advertisement.
- The retailers have to provide fruits and vegetables in fresh condition as expected by the customers

CONCLUSION

- Consumer buying behaviour is gate way of success in markets.
- Consumers behaviour is an important factors that will help them to tap the consumer in a better ways.
- The retailers should helps customers to explore the store.
- Consumers always looks the benefits of shopping in an organized retail store over the traditional retail outlets in terms of self-selection, variety , and also seek value for the money they pay.



A STUDY ON CUSTOMERS' AWARENESS, PREFERENCES AND SATISFACTION TOWARDS AJIO ONLINE SHOPPING APP IN COIMBATORE CITY

***Mr. R. Mayilsamy**

**Assistant Professor in Commerce with Professional Accounting, Dr N.G.P Arts and Science College,
Coimbatore*

****Ms.M.Kungumadevi**

*** Student, III Year in Commerce with Professional Accounting, Dr N.G.P Arts and Science College,
Coimbatore*

ABSTRACT

Online shopping is becoming increasingly popular for variety of reasons. There are certainly outside factors such as increasing gas prices, difficulty in getting to traditional stores and hassles often associated with shopping malls and other traditional stores to contribute to the increased interest in online shopping. Consumers can get full information about the product with its reviews being passed by the existing users. If one wants to buy a product he/she is no longer limited to asking the friends and families because there are many products reviews on the web which gives opinions of the existing users of the product.

KEYWORDS : *Online shopping, quality, customer satisfaction, product, price.*

INTRODUCTION

Online shopping is the most popular feature around the world . People are tending to do online shopping by using those social media and also by using online shopping websites. As well as most of the business organizations try to use online shopping to sell their product and to increase their market. E-SHOPPING is a boon as it saves lot of time. Online shopping is a process whereby consumers directly buy goods, services etc. from a seller without an intermediary service over the Internet. Shoppers can visit web stores from the comfort of their house and shop as by sitting in front of the computer.

Ajio app is one of the online shopping app where you can buy clothing & accessories for mens, womens, & kids through the internet access.

STATEMENT OF THE PROBLEM

The problem is to analyse the Customers Preferences and Satisfaction towards the Ajio Online Shopping app and also to bring some awareness about the Ajio online shopping app among the peoples in coimbatore city.

SCOPE OF THE STUDY

Online buying is happening in India in a large scale as it will replace all traditional and store shopping in the near future. This study is to help the society to know about the ajio online shopping app. This study will help the business organizations to make decision about their business and also the people's can gain knowledge about the Ajio Online Shopping App.



OBJECTIVE OF THE STUDY

- To identify the Customers Preferences about the Ajio online shopping app.
- To assess the factors influencing customer satisfaction while doing online shopping and their level of satisfaction.
- To bring some Awareness to the Customers and Society about Ajio online shopping app.

RESEARCH METHODOLOGY

DATA COLLECTION

The study includes both primary and secondary data

- Primary data for this project was collected through questionnaire.
- Secondary data for this project has been collected through journals, Articles , magazines, books from library, etc.,.

RESEARCH DESIGN

The research design used for the study is Descriptive.

SAMPLE AND SAMPLE TECHNIQUES

The sample of 120 respondents has been chosen by using Convenience sampling technique.

TOOLS USED

In this study, tools used for research purpose are

- Percentage analysis
- Likert scale analysis

AREA OF THE STUDY

The targeted population for this study is customers living around the Coimbatore area, those who have internet facility in their living place or working place.

REVIEW OF LITERATURE

Dr.R.Shanthi Dr. DestiKannaiah(2015) examined Consumers' perception on online shopping. The purpose of this study is to identify the factors influencing consumer to buy online. And also analyzed the type of products purchased by consumers through online shopping. This review has said about the consumers attitude towards online shopping. This review has highlighted the fact that the youngsters between the age 20 – 25.

Dr.D.Sudhakar (2016) analysed that online shopping has become a daily part of our lives mainly because it is so convenient. The web allows customer a comparison buy the mode effective deals and fine product that might otherwise be difficult to find it. Online shopping can be easy and pleasurable with some precaution . Online shoppers expects to visualize sensible deals online amid free or terribly low price shipping. Consumer are looking for trust, security, customer service, privacy of data , timelines, accessibility, convenience, customer service, cost and wider choice throughout online shopping.

DATA ANALYSIS AND INTERPRETATION

The data have been analysed using the following systematic tools:

- Simple percentage analysis
- Likert scale analysis

SIMPLE PERCENTAGE ANALYSIS

The percentage analysis is mainly used to find the distribution of different categories of respondents. As the values are expressed in terms of percentage it facilitates comparison and standardization. The Analysis describes the classification of the respondents falling under each category.

$$\text{Percentage} = \frac{\text{Number of respondents}}{\text{Total number of respondents}} * 100$$

TABLE SHOWING THE MONTHLY INCOME OF THE RESPONDENTS

INCOME	NO. OF RESPONDENTS	PERCENTAGE
Below 20000	21	17.50%
20000 – 50000	28	23.33%
50000 – 100000	9	7.50%
Above 100000	18	15.00%
Others	44	36.67%
Total	120	100%

Source: Primary data



INTERPRETATION

The above table indicates that 17.50% of the respondents earns income below 20000, 23.33% of respondents earns income between 20000 - 50000, 7.50% of the respondents earns income between 50000 – 100000, 15.00% of respondents earns income above 100000 and 36.67% of the respondents belongs to other category .

Majority 36.67% of the respondents belongs to other category since they are students they may not be earning.

LIKERT SCALE ANALYSIS

The Likert Scale is a raising scale that's often used when surveying your customer regarding their experiences with your brand – from the service they were provided to the overall effectiveness of your product.

LIKERT SCALE =

SUM OF (FX)/NUMBER OF RESPONDENTS

F= NO. OF RESPONDENTS

X = LIKERT SCALE VALUE

(FX)=TOTAL SCORE

TABLE SHOWING THE CUSTOMER SATISFACTION LEVEL ON ONLINE BUYING

LEVEL OF SATISFACTION	NO. OF RESPONDENTS (F)	LIKERT SCALE VALUE (X)	TOTAL (FX)
Highly Satisfied	26	5	130
Satisfied	41	4	164
Neutral	21	3	63
Dissatisfied	11	2	22
Highly Dissatisfied	21	1	21
Total	120		400

Source: Primary data

INTERPRETATION

Likert scale = sum (FX) / total no. of respondents

= (400/120)

= 3.33333

FINDINGS , SUGGESTIONS & CONCLUSION OF THE STUDY

Findings of Simple Percentage Analysis:

- It is found that Majority 55% of the respondents are females.
- It is found that Majority 34.17% of respondents are using Flipkart online shopping application.
- It is found that Majority 51.67% of the customers are giving importance to the Trust as an Mostly important factor influenced in online buying.
- It is found that Majority 51.67% of the customers are giving importance to the Services as an important factor influenced in online buying .
- It is found that Majority 37.5% of the customers are giving importance to the

Quality as an important factor influenced in online buying .

- It is found that Majority 35.83% of the respondents are using Ajio App Recently because they didn't have awareness about this Ajio App.

Findings of Likertscale Analysis

This likert scale analysis reveals that the customers are satisfied by using ajio online shopping app and they gives an average score of 3.3333.

SUGGESTIONS

- In Ajio app there are more procedures to do online buying so it is difficult to use this so the procedures can be reduced.
- Delivery charge can be reduced.
- There should not be fluctuations in the price of the products.
- I suggest all to use this awesome online shopping app.



CONCLUSION

The online shopping applications are playing a very major role in this current scenario. In my study I found that customers are highly satisfied by the qualities & services of using this ajio online shopping App. A very Good application among the other online shopping applications. The customers are very much happy of the assured products by Ajio. I have suggested everyone to use this Ajio online Shopping App because the products are of very good quality, price is affordable, variety of products available, Instant Coupon discounts, on time Delivery all over India, very satisfied Customer Services, trustful products & services and the products are Awesome. Ajio is the best platform to do Online Shopping.

REFERENCE

1. *Shanthi Dr. Desti Kannaiah (2015), Consumers' perception on online shopping", Journal of Marketing and Consumer Research, ISSN:2422-8451, Vol.13.*
2. *Dr.D.Sudhakar (2016), "A study on consumer satisfaction towards online shopping with special reference to Chennai city", IRACT-International Journal of Research in Management & Technology, ISSN:2249-9563.*



A STUDY ON CUSTOMER'S PREFERENCE AND SATISFACTION TOWARDS ORGANIC EDIBLE OIL WITH SPECIAL REFERENCE TO COIMBATORE CITY

Mr.R.Mayilsamy

*Assistant Professor, Department of Commerce with Professional Accounting ,
Dr. N.G.P. Arts and Science College, Coimbatore*

Jayashree.R

*Student of III B. Com (PA), Department of Commerce with Professional Accounting ,
Dr. N.G.P. Arts and Science College, Coimbatore*

ABSTRACT

The Definition of the word “Organic”, an ecological management production system that promotes and enhances biodiversity, biological cycles and soil biological activity. It is based on the minimal use of off-farm inputs and on management practices that restore, maintain and enhance “ecological harmony” (National Standards Board of the US Department of Agriculture(USDA). Organic edible oil production is a self-regulated industry with government oversight in some countries, distinct from private gardening.

INTRODUCTION

There is no common definition of “organic” due to the fact that different countries have different standard for products to be certified “organic”. In simplest words organic edible oil are minimally processed to maintain the integrity of the organic edible oil without artificial ingredients, preservatives or irradiation.

Organic edible oil are obtained by processes friendly to the environment, by cultivation techniques that consider both the attributes of the final product and the production methods

THE BIGGEST ADVANTAGES OF ORGANIC EDIBLE OIL INCLUDE

Nutrient-Denser organic edible oil: According to a State of Science Review done in 2008, organic edible oil has more nutritional superiority than its non-organic edible oil counterparts.

Stronger, More Energetic Body: No pesticides, chemicals, or processed additives bogging down your system means a smaller risk of disease, illness, and disorders in yourself. Nothing leaves you feeling tired and gross like unhealthy junk organic edible oil.

It Tastes Better: True, it may not taste as good if you're accustomed to the addictive qualities of junk organic edible oil additives, such as processed sugar and MSG. But after just a short time of your body experiencing truly healthy organic edible oil, you'll be craving it. No, really, you will. And all the crap will start having a bad after-taste.

SCOPE OF THE STUDY

Organic edible oil promotes a balance of human, other living organisms and the nature. It also with rising concern of health issues and organic edible oil safety, many consumers have turned their site to organic edible oil. The increased consumers' interest in organic edible oil has been attributed among others to the growing demand for organic edible oil free from pesticides and chemical residues promotes no artificial preservatives and best maintain the originality of organic edible oil. This prevents excess use harmful ingredients and thereby ensures health. This study attempted to gain knowledge about consumer attitude towards organic edible oil product consumption and to see whether there is any potential this might have for changing their behavior.



STATEMENT OF THE PROBLEM

Growth in organic edible oil markets in India may occur for a number of reasons. They may be related to changes in consumers lifestyles (promotion of a healthier lifestyle) and the growth in awareness of consumers regarding organic edible oil quality. Also, consumer awareness of the need for environment protection is increasing. Organic edible oil farming is often considered by consumers as environmental friendly, and this may result in more attention given by consumers to organic edible oil farming.

OBJECTIVES OF THE STUDY

- To study the consumer preference and purchasing behavior for various types of organic edible oil.
- To find out the factors influencing the consumers decision making choice for organic edible oil.
- To analysis the level of satisfaction of respondents towards organic edible oil.
- To problem faced by the customers in using organic edible oil.

RESEARCH METHODOLOGY

METHODS OF DATA COLLECTION

- The study is used both primary and secondary data. The primary data were collected from the respondents who are using organic edible oil with the help of interview schedule.
- The secondary data has been collected from various resources such as books ,magazines, journals, articles, newspaper etc..

AREA OF THE STUDY

Coimbatore city was selected as it is a commercially vibrant town surrounded by more number of villages and it is the hub of Salaried and middle income people.

SAMPLE SIZE

The sample size for the present study was 120 respondents.

TOOLS USED FOR ANALYSIS

- Simple percentage
- Likert’s scale analysis
- Rank analysis

LIMITATIONS OF THE STUDY

- The responses given by the respondents have been taken as genuine no further verification is made.
- Time is a limiting factor in carrying out an extensive research work.

REVIEW OF LITERATURE

Dr. V. Maheswari(2019) , the study entitled “A STUDY ON CONSUMER PERCEPTION AND SATISFACTION OF ORGANIC EDIBLE OIL IN KUMBAKONAM TOWN”. The study examined purified drinking water is essential to every citizen. To know the level of satisfaction on organic edible oil and problem faced by the respondents in using the organic edible oil. She found that majority 69% of the respondent were satisfied overall performance of the brand. She suggested most of the respondents have pinpointed to reduce wastage of water in the purification process. She concluded that large section of public are spending a lot of installation of purifier or buy purified water for their survival.

Dr.A.Gunasundari et al (2018) , the study entitled “A COMPARATIVE STUDY OF FACTORS AFFECTING CONSUMER PREFERENCE BETWEEN LOCAL AND BRANDED ORGANIC EDIBLE OILS WITH SPECIAL REFERENCE TO THIRUVARUR” .The study examined on the perception of consumer and consumer awareness towards organic edile oils. To analyze the impact of brand preference and find out factors affects consumer purchase decision.

DATA ANALYSIS AND INTERPRETATION

The collected data were groped, edited, tabulated in a master table and analysed using the following statistical tools.

- Simple percentage analysis
- Likert scale analysis
- Ranking analysis

FORMULA FOR PERCENTAGE ANALYSIS

$$\text{PERCENTAGE} = \frac{\text{Number of respondents}}{\text{Total number of respondent}} \times 100$$

**TABLE SHOWING THE MONTHLY INCOME OF THE RESPONDENTS**

Monthly income	No of the respondents	Percentage
Below 20000	40	35%
20001-40000	55	50%
40001-60000	15	12%
Above 60000	5	3%
Total	120	100%

INTERPRETATION

The above table shows that out of 120 respondents, 35% of respondents are belongs to the income group of below Rs20000,50% of the respondents are Rs.20001-40000,12% of the

respondents are Rs.40001-60000, and 3% respondents are above 60000.

Majority of the respondents are belongs to the income level of Rs.20001-40000.

TABLE SHOWING THE RANK ANALYSIS OF FACTORS INFLUENCING THE ORGANIC EDIBLE OIL

FACTORS	1	2	3	4	5	6	Total	MEAN SCORES	RANK
Product (f) availability scores	14	13	13	15	51	14	120	3	5
Price (f) Scores	84	65	52	45	102	14	432	2.4	6
Nutritious(f)	0	26	1	16	39	38	120	2.4	6
Health benefits Scores	0	130	4	48	78	38	298	3.8	2
Taste (f) And color Scores	20	14	48	13	11	14	120	3.8	2
Chemical(f) Free Scores	120	70	192	39	22	14	457	3.7	3
Quality (f) Scores	13	33	21	27	13	13	120	3.7	3
	78	165	84	81	26	13	447	3.6	4
	33	21	14	14	2	36	120	3.6	4
	198	105	56	42	4	36	441	4.1	1
	27	26	23	35	4	5	120	4.1	1
	162	130	92	102	8	5	502		

INTERPRETATION

From the above table shows that rank analysis of factors influencing the organic edible oil ,majority of the respondents said that quality if organic edible oil is ranked as1,next most of the respondents said that nutritious health benefits of organic edible oil is ranked as2, next most of the respondents said that

taste and color of organic edible oil is ranked as3, next most the respondents said that chemical free of organic edible oil is ranked as4, next most of the respondents said that product availability of organic edible oil is ranked as5, next most of the respondents said that price of organic edible oil is ranked as6.

TABLE SHOWING THE LEVEL OF SATISFACTION OF PRICE

S.NO	FACTORS	NO.OF.RESPONDENTS	TOTAL SCORE
1	Highly satisfied	4	20
2	Satisfied	3	12
3	Neutral	70	210
4	Dissatisfied	40	80
5	Highly dissatisfied	3	3
6	Total	120	325

Most favourable attitude = $120 \times 5 = 600$

Neutral attitude = $120 \times 3 = 360$

Most unfavourable attitude = $120 \times 1 = 120$



INTERPRETATION

Response regarding quantity of organic edible oil was less than neutral value. Therefore according to likerts summated scale, the respondents are dissatisfied with price of organic edible oil.

FINDINGS AND SUGGESTIONS

PERCENTAGE ANALYSIS

- Majority 63% of the respondents are female.
- Most 31% of the respondent are in the age group of 36-50 years
- Majority 59% of the respondents are married.
- Most 20% of the respondents are graduate.
- Most 32% of the respondents are employee.
- Majority 50% of the respondents are belongs to the income groups of above 20000.
- Majority 48% of the respondents are in rural area.
- Most 59% of the respondents have 4 members in their family.
- Most 48% of the respondents are using organic edible oil for 3-5 years.
- Most 43% of the respondents are using organic coconut oil.
- Most 45% of the respondents are spent Rs751-Rs1000 for purchasing organic edible oil.

RANK ANALYSIS

- Majority of the respondents said that quality of organic edible oil is ranked as 1
- Next most of the respondents said that nutritious health benefits of organic edible oil is ranked as 2
- Next most of the respondents said that taste and color of organic edible oil is ranked as 3

LIKERT SCALE ANALYSIS

- Response regarding quality of organic edible oil was more than neutral value .therefore according to likerts summated scale, the respondents are satisfied with organic edible oil
- Response regarding taste and color of organic edible oil was more than neutral value .therefore according to likerts summated scale, the respondents are highly satisfied with taste and color of organic edible oil
- Response regarding quantity of organic edible oil was less than neutral value. Therefore according to likerts summated scale, the respondents are dissatisfied with quantity organic edible oil
- Response regarding price of organic edible oil was less than neutral value. Therefore

according to likerts summated scale, the respondents are dissatisfied with price organic edible oil

SUGGESTIONS

- The rate of organic edible oil is high ,though it is reasonable .but the expectation of consumers is that price of organic edible oil can be made competitive with normal terms.
- Organic edible oil are not yet popular among consumers .hence, steps should be taken to popularize the organic edible oil.
- Number of outlets for organic edible oil is very limited . if more of shops are opened it will be convenient for consumers to buy them.
- The variety aspect of organic edible oil is low .therefore the variety of items should be increased

Apart from the above the government agency should procures organic edible oil. at present there is no buy organic edible oil government shop. And there is a misconception among the public.

CONCLUSION

Majority of the respondents were aware of organic edible oil, benefits and problems associated with conventional organic edible oil .however, this awareness was relatively more among educated respondents . but most majority buy conventional me not used buy organic edible oil regularly due to some prominent reasons like-

- 1.High price of goods.
- 2.Lack of information related from where to buy.
- 3.Lack of availability
4. Risk of getting cheated

Effective marketing structure and necessary support from the governmental agencies for organic edible oil is required .it can also be done through NGOs and other government agencies since it is safer and healthier organic edible oil along with private sector participation . improvement in supply chain management and production planning will solve the issues like irregular supply, limited stocks. It is the time for government to take effective policy decision in association with agriculture department to encourage farmers to produce and market organic edible oil.

REFERENCE

1. *Dr.V.Maheswari(2019), "A study on consumer perception and satisfaction of ORGANIC EDIBLE OIL in Kumbakonam town". Volume-6, Issue 2, March – April 2019, pp: 240–246, ISSN Print: 2347-3940 and ISSN Online: 2347-3959*



2. *Dr.A.Gunasundari,Dr.R.Vanitha,S.Senthilvel,V .Rengarajan,V.Vijayanand,C.Kathirvel Babu (2018) "A comparative study of factors affecting consumer preference between local and branded ORGANIC EDIBLE OILs with special reference to Thiruvarur".Volume-119 No.10 2018,pp: 1591-1602,ISSN Print:1311-8080,ISSN Online:1314-3395.*



A STUDY ON CUSTOMERS' PERCEPTION TOWARDS DIGITAL PAYMENT SYSTEM WITH SPECIAL REFERENCE TO TIRUPPUR CITY

Dr. R. Mayilsamy

*Assistant Professor, Department of Commerce with Professional Accounting
Dr. N.G.P. Arts and Science College, Coimbatore*

Mr. Gokula Krishnan. D

*Student, Department of Commerce with Professional Accounting, Dr. N.G.P. Arts and Science College,
Coimbatore*

ABSTRACT

According to the study it appears that many people actually agree with the government on the usefulness of cashless economy as it helps to fight against terrorism, corruption, money laundering but one biggest problem in the working of cashless economy in India is cyber crime and illegal access to primary data. It was found that demographic factor expect education does not have much impact on the adoption of the digital payment. It indicates that adoption of digital payment is influenced by the educational level of the customer. The growth of users of smart phone and internet penetration in such area also facilitated the adoption of digital payment.

KEY POINTS: *Cashless economy, corruption, money laundering, cyber crime, digital payment.*

INTRODUCTION

The Government of India has been taking several measures to promote and encourage digital payments in the country. As part of the "Digital India" campaign, the Government aims to create a "Digitally Empowered" economy that is "Faceless, Paperless, Cashless". There are various types and modes of digital payments. Some of these include the use of Debit / Credit cards, Internet banking, Mobile wallets, Digital payment apps, Mobile banking, Aadhaar Enabled Payment System (AEPS), etc...

STATEMENT OF THE PROBLEM

The current scenario of Indian economy shows the tendency of movement from cash to digital transactions. There are so many efforts have been taken by the government in order to convert the face of Indian economy into a new one. Now a day every

transaction is going digital. In order to accelerate the execution of the concept of digital economy there are number of digital payment systems were introduced. These payment systems can make changes in the economic life of people. Literacy is also another factor affecting the awareness level especially towards the digital payment system.

SCOPE OF THE STUDY

The scope of the study is to know the level of satisfaction of customer with respect to various services of digital payment systems.. This study is aiming to know the best marketing strategy. It also aims to know the awareness about different digital payment applications . Customer satisfaction is dynamic, therefore it is necessary to study analysis and monitoring effective decisions can be taken in respect of services, security, flexibility, complexity and usage.

**OBJECTIVES**

- To make an overview regarding growth in digital transactions in India.
- To study the awareness level of digital payment system among the respondents.
- To study the perception level towards safety on digital payments.
- To understand the impact of demographic factors on adoption of digital mode of payment.

RESEARCH METHODOLOGY

SOURCE OF DATA: The study includes both primary and secondary data.

SAMPLE DESIGN: The sample design used to collect data from the respondents is convenient sampling.

AREA OF THE STUDY: Study is conducted in Tiruppur city only.

SAMPLE SIZE: The sample size which is taken for the study 120 Respondents only.

REVIEW OF LITERATURE

K.Suma Vally, Dr. K.Hema Divya (2018), "A study on Digital payments in India with perspective of Consumers adoption" the study examines the effect of adopting digital payments impact on customers of the banking sector of India. The result put together gives us an important policy direction towards what can enable the country to increase

cashless payments. The results indicate that the deployment of technology for digital payments have improved the performance of banking sector and able to achieve the motive cash less country. The study gives emphasis to the percentage of awareness on maximum utilization of technology. Banks should take effective measures in creating awareness towards the effective usage of technology and security

Dr. Karminder Ghuman and CS Shruti Srivastava (2017) in their paper "Recharging: the Right Way?? A case study on e-payment giants: Freecharge & PayTM" has asked readers a strategic question that in the emerging internet based service provision industry, whether it is a better strategy to develop a unique positioning on the basis of single key service or it's better for an organization to offer multiple services, thereby reducing risk, increasing traction and thus increasing its valuation. Thus they have compared Paytm and Freecharge who are employing opposite strategies to find out which one is better.

PROFILE OF THE STUDY

A Digital Economy is an economy in which all types of transactions are carried out through digital means. It includes e-banking (mobile banking or banking through computers), debit and credit cards, card-swipe or point of sales (POS) machines and digital wallets.

ANALYSIS

TABLE SHOWING THAT HOW OFTEN THEY USE THE DIGITAL PAYMENT SYSTEM OF THE RESPONDENTS

S.NO.	FACTORS	NO.OF RESPONDENTS	PERCENTAGE
1.	Daily	16	13
2.	Weekly once	41	34
3.	Monthly	46	39
4.	Occasionally	17	14
	Total	120	100

(Source: Primary data)

INTERPRETATION

The above table shows out of total 120 respondents, 13% of the respondents are using the digital payment daily, 34% of the respondents are using the digital payment weekly once, 39% of the respondents are using the digital payment monthly,

14% of the respondents are using the digital payment occasionally.

- **Majority, 39% of the respondents are using the digital payment Monthly.**

**TABLE SHOWING THE PREFERENCE LEVEL OF DIGITAL PAYMENT SYSTEM TO THE RESPONDENTS**

S.NO.	FACTORS	RANK 1	RANK 2	RANK 3	RANK 4	RANK 5	TOTAL	RANK
1.	Fund transfer	65(5)	9(4)	15(3)	10(2)	21(1)	447	1
2.	Online shopping	11(5)	47(4)	22(3)	26(2)	14(1)	375	3
3.	Payment of mobile bills	24(5)	31(4)	54(3)	9(2)	2(1)	426	2
4.	Electricity bill payment	12(5)	29(4)	25(3)	46(2)	8(1)	351	4
5.	Booking movie tickets	8(5)	4(4)	4(3)	29(2)	75(1)	201	5

(Source: Primary data)

INTERPRETATION

The above table shows that out of 120 respondents Fund transfer has ranked 1st, Payment of mobile bills has ranked 2nd, Online shopping has ranked 3rd, Electricity bill payment has ranked 4th, Booking movie tickets has ranked 5th.

Fund transfer has ranked 1st.

FINDINGS

1. SIMPLE PERCENTAGE ANALYSIS

- 59% of the respondents are 18 Years – 27 Years
- 54% of the respondent are Female
- 61% of the respondent are Unmarried
- 55% of the respondents are Graduate
- 40% of the respondents are Employee
- 50% of the respondents annual income of the family is Upto Rs.250000
- 58% of the respondents are using the Digital Payment for 2 Years – 4 Years.
- 42% of the respondents prefer the Digital Payment System for Convenience.
- 53% of the respondents are using the Debit card.
- 39% of the respondents are using the digital payment Monthly.
- 47% of the respondents issue regarding the digital payment is Server Problem.
- 38% of the respondents use the digital payment to Reduces risk
- 82% of the respondents have installed malware or antivirus protection on their phone or laptop
- 47% of the respondents are changing passwords, PIN of debit/credit cards once in 6 months

2. RANKING ANALYSIS

- Fund transfer has ranked 1st.
- Price of using digital payment mode has ranked 1st.

3. LIKERT SCALE ANALYSIS

- Likert scale value is 4.15 which is Greater then the mid value (3), so the customers are satisfied with the Quality of Digital Payment System.
- Likert scale value is 4.54 which is equal to the mid value (3), so the customers are Highly satisfied with the Digital Payment Saves cost and time for my financial transactions.
- Likert scale value is 4.15 which is Greater then the mid value (3), so the customers are satisfied with the Digital Payment is convenient to me.
- Likert scale value is 2.95 which is equal to the mid value (3), so the customers are neutral with the Digital Payment is safe and secured.
- Likert scale value is 3.10 which is equal to then the mid value (3), so the customers are neutral with the Digital Payment is delay in its process.
- Likert scale value is 2.90 which is equal to the mid value (3), so the customers are neutral with the Digital Payment has low level of risk.

SUGGESTIONS

- The Digital payment system has to take necessary steps to overcome delay in processing of payments.
- To offer discounts/cash back offers to attract more number of customers.
- Server problem should be overcome in order to make quick transactions.
- Malpractice should be reduced to protect customers personal information safely.

CONCLUSION

From the above analysis it also appears that many people actually agree with the government on the usefulness of cashless economy as it helps to fight against terrorism, corruption, money laundering but one biggest problem in the working of cashless economy in India is cyber crime and illegal access to primary data.



It was found that demographic factor expect education does not have much impact on the adoption of the digital payment. It indicates that adoption of digital payment is influenced by the educational level of the customer. The growth of users of smart phone and internet penetration in such area also facilitated the adoption of digital payment.

REFERENCE

1. K.Suma Vally, Dr. K. Hema Divya (2018) "A Study on Digital payments in India with perspective of Consumers adoption" *International Journal of pure and Applied Mathematics Volume 118 No. 24 2018* ISSN: 1314 – 3395 (on-line version).
2. Dr.Karminder Ghuman and Shruti Srivastava (2017) "A Study on e-payment giants: freecharge & paytm" *IOSR Journal of Business and Management e-ISSN:2278-487X, P-ISSN:2319-7668*.
3. Zahoor Ahmad Shah (2017) "Digital Payment System: Problems and Prospects" *EPRA International Journal of Economic and Business Review, Volume - 5, Issue- 8, Research Paper IC Value: 56.46 e-ISSN: 2347 - 9671| p- ISSN : 2349 – 0187*.
4. Shamsher Singh, (2017), "Study of Consumer Perception of Digital Payment Mode" *Journal of Internet Banking and Commerce, 22(3), pp.1-14*.
5. Shukla, T. N., *Mobile wallet: present and the future, Vol. 5, No. 3, June 2016 (ISSN 2278 – 5973)*. Available: ssijmar.in/vol5no3/vol5no3.6.pdf.



CONFLICTS IN THE TURKESTAN SYSTEM OF GOVERNMENT (1917)

Abdullaev Zafar

Teacher of Namangan State University

ABSTRACT

Tsarist Russia period was important in Uzbek history especially The February Revolution of 1917 disrupted the system that had been formed for decades, not only in the central provinces of Russia, but also in Turkestan itself, and the previous agreements, guidelines, and orders had lost their force in practice. At the same time, in the absence of full implementation of the existing legal and regulatory documents of Tsarist Russia, the Provisional Government itself issued orders and decrees, decrees, had to issue instructions along the way. Turkestan was based on legal and regulatory documents, in general and in some areas, depending on the conditions of the country. And again, the relationship between the two sides was based on military-political governance. This was under the control of the Governor-General in Turkestan and his military governors in the provinces. The February Revolution of 1917 disrupted the system that had been formed for decades, not only in the central provinces of Russia, but also in Turkestan itself, and the previous agreements, guidelines, and orders had lost their force in practice. At the same time, in the absence of full implementation of the existing legal and regulatory documents of Tsarist Russia, the Provisional Government itself issued orders and decrees, decrees, had to issue instructions along the way. Moreover, the ongoing war, even after the fall of Tsarist Russia, had in fact exacerbated the chaos. Thus, despite the fact that the February Revolution of 1917 created great opportunities for Russia and its peripheral countries in the democratic process, political movements, party formation, it did not allow true freedom, self-determination of nations, elections on a democratic, equal basis.

KEYWORDS: *revolution, democratic, force, revolution, province, restriction, legal.*

INTRODUCTION

The February Revolution of 1917 was a democratic process for the peoples of the Russian Empire, especially for Turkestan, a remote country: equal elections, overcoming economic dependence, active participation in the socio-political life of the country, expanding opportunities for indigenous peoples in the system of governance, expanding political rights, lifted cultural and educational restrictions and gave hope for reforms in the administrative, political, cultural and educational spheres in the country. Of course, the changes in all directions, the reforms were to be in the interests of the people of Turkestan, all of which had to be carried out on the basis of relevant legal and regulatory documents. For decades, Russian rule in Turkestan was subordinated to the interests of the empire, and the socio-political, military, economic, cultural and enlightenment life of the country was completely extinguished by the interests of the

metropolis. Of course, the administration in Turkestan was based on legal and regulatory documents, in general and in some areas, depending on the conditions of the country. And again, the relationship between the two sides was based on military-political governance. This was under the control of the Governor-General in Turkestan and his military governors in the provinces. The February Revolution of 1917 disrupted the system that had been formed for decades, not only in the central provinces of Russia, but also in Turkestan itself, and the previous agreements, guidelines, and orders had lost their force in practice. At the same time, in the absence of full implementation of the existing legal and regulatory documents of Tsarist Russia, the Provisional Government itself issued orders and decrees, decrees, had to issue instructions along the way. Moreover, the ongoing war, even after the fall of Tsarist Russia, had in fact exacerbated the chaos. However, it should be noted that despite the February



Revolution and the overthrow of the tsarist government, the former governor-general of Turkestan continued to rule the country, especially in the wake of the growing revolutionary mood, "in his order to the [military] governors of the officials said they would continue to perform their duties. In a telegram sent to the military governor of the Samarkand region on March 13, 1917, he said that "Russian representatives in the ranks of members of the city Duma (Parlament) should be at least half of the members of the Duma". Because, in his opinion, the natives of Turkestan are like the Russians ... they should not be equal to them in law". The content of the telegram sent to A.N.Kuropatkin by A.Miller, a resident of Russia in Bukhara, shows that the violation of the rights of the local population continues in Bukhara. The telegram stated that the non-participation of 5,000 Russian Muslims in the March 12, 1917 elections to the Executive Committee in New Bukhara had provoked strong protests, in which it was stated that "the non-participation of Muslims on an equal footing with other Russian citizens disturbed the mood".

Based on the above historical evidence, it can be said that General A.N.Kuropatkin refused to unconditionally comply with the decree, orders, despite the change of power in the Center, the formation of the Provisional Government and the relevant decrees, and, if necessary, tried to express his "objection" to them. Failure to comply with the decrees, orders, decrees, resolutions and instructions adopted by the Provisional Government in the conditions of Turkestan was a sign of the chaos in the system of governance in the country, the legal and regulatory imbalances of the old and new order. It can be said that neither the legal documents of the Tsarist period nor those of the Provisional Government served the interests of the native population of Turkestan provinces to prosecute the participants in the 1916 uprising. not to start a new job ... in early March 1892 on the basis of the Statute to form public committees for elections to the City Duma, to replace the police with the police and a search point in the security department INI liquidation orders [1]. Of course, A.N.Kuropatkin's continued orders and directives ... are still evidence that the former governor-general in Turkestan is "showing that his rights are not restricted" or that the interim government is relying on the former governor-general as a base that has no practical and legal influence.

Although the Provisional Government issued a decree on March 4, 1917, "granting equal civil rights" to all peoples, General A.N.Kuropatkin said that the country's Muslim population has no military obligations and therefore the principle of "equality cannot be fully applied to them, otherwise Turkestan

will go back: the majority of the vote will remain in the regimes and they will take everything into their own hands, which is unreliable [1, 24]. In practice, it "returns the smoke". He continued his "arbitrariness" in practice, and in his order of March 8, 1917, he continued to work until a new order came from the Provisional Government. But at the same time, the legal complexity in this system of governance could not last very long. Gradually, executive committees of public organizations began to be formed throughout Turkestan to replace the tsarist administration, which had been abolished by the Provisional Government. The executive committees set up in Tashkent and other cities also included locals, who were still a minority. In practice, progressive-minded, political activists are dissatisfied with the elections to the executive committees, and only A.N. They also expressed their views to Kuropatkin's court, but also to the chairman of the Russian Council of Ministers, the foreign minister, and the Muslim faction in the State Duma. In Turkestan, too, the process of dual power began to emerge[2]. Of course, this dualism could not last long. According to the decision of the Provisional Government, A.N.Kuropatkin and his relatives were removed from office, and on April 7, 1917, the Turkestan Committee of the Provisional Government was established under the leadership of N.N.Shchepkin, which was given the legal status of governing the country. Now the committee has the right to operate in Samarkand, Syrdarya, Ettisuv, Kasbiyorti, Fergana regions of Turkestan and even in Bukhara and Khiva. For a short time, however, the legal turmoil in Turkestan was resolved. However, although the composition of the Turkestan committee was set at 9, only 4 of them were representatives of the Turkic-Muslim peoples. Of those 4, 2 were Kazakhs and 2 were Tatars. Of the multi-million Turkic peoples, only two, A.N.Bukeikhanov and M.Tinishpaev of Kazakh descent, were involved as indigenous peoples, while S.N.Maksudov and A.Davletshin of Tatar origin came from the Volga region. The absence of representatives of Uzbek, Kyrgyz, Turkmen, Tajik, and Karakalpak nationalities in the committee was also a sign that the rights of indigenous peoples were not taken into account [2]. Speaking at a meeting of the committee headed by N.N.Shchepkin, Mahmudkhoja Behbudi said: "... without knowing our lives, we have no choice but to govern. o m a (separated from us - Z.A.)". Indeed, the majority of the committee members, unaware of the situation in Turkestan, the way of life, history, production, culture, traditions and customs of the peoples, had to develop and implement legal documents in Turkestan. Furthermore, most of the committee members did not have an understanding of the language and culture of



the peoples of the country, or of Eastern law: what could be forbidden and what should be allowed [2, 19-22].

In Turkestan, in March-April 1917, workers 'and soldiers' deputies were also formed. In March 1917 alone, 75 working-class deputies began to work in Turkestan. But the composition of these soviets was also predominantly European, with none of the natives under his leadership. They also began to show their legal involvement in the management of Turkestan. At the same time, national organizations began to be formed in the country. In particular, the Shorai Islamiya was formed in March 1917, the Shorai Ulamo in June 1917, and the Turkist Centralist Party (Turkistan Federalist Party) in July 1917. Now these political forces have begun to assert their claim to be defenders of Muslim rights. On April 16-23, 1917, at the initiative of the "Islamic Council", the first congress of Muslims of All-Turkistan was held, at which about 20 issues were considered. The congress decided to return the confiscated lands to the local population, emphasizing the need for all citizens, regardless of gender, religion or nationality, to be equal before the law and to have freedom of conscience, freedom of speech, home and person, association and organization [2, 19-22]. The congress also decided to include Turkestan in Russia as a separate territorial autonomy in the construction of national statehood.

Thus, in Turkestan, the Turkestan Committee of the Provisional Government, the Council of Workers 'and Soldiers' Deputies, the organization "Shura Islamiya" (since April, the Provincial Council of Muslims - Kraymussovet) began to operate in the political sphere of the region. Different approaches to the issue of giving a legally appropriate status to the system of governance of Turkestan began to emerge. In particular, the Turkestan Committee of the Provisional Government concluded that full political autonomy for Turkestan was impossible[3, 11-13]. Delegates from socio-political organizations and movements in the country met in Tashkent on April 9-16, 1917. the Russian delegates were in the majority. Z.A.) "opposed the granting of autonomy to Turkestan on the pretext that Muslims were not yet politically and culturally ready for autonomy". A similar decision was made at the I Provincial Congress of the Soviets of Workers 'and Soldiers' Deputies, which was held almost simultaneously. Now the decisions of the Provincial Congress of the Turkestan Committee of the Provisional Government and the Soviets of Workers 'and Soldiers' Deputies have been adopted as instructions by the local authorities. This was in fact contrary to one of the decrees issued by the Provisional Government in March 1917, which stated that "... all existing regulations restricting the rights

of Russian citizens concerning their nationality ... shall be repealed". This was a sign of the legal coordination in the Provisional Government and the system of local government, which in practice could not pass from the declaration to the oil. At the same time, it can be seen that the approach of local intellectuals and Russians and Russian-speakers to the legal status of the Turkestan system of government is different. It can be said that legal discrimination against the population of the region was an expression of contempt and disregard for it. One of the heads of the Provisional Government, A.F.Kerensky, wrote in his diary on April 29, 1917, A.N. He agreed with me that it is not right to give full rights to regimes with unequal obligations to the Russian people [4, 36-37].

CONCLUSION

Thus, despite the fact that the February Revolution of 1917 created great opportunities for Russia and its peripheral countries in the democratic process, political movements, party formation, it did not allow true freedom, self-determination of nations, elections on a democratic, equal basis. In particular, this can be seen in the chaos in the status of the Turkestan system of government after the February Revolution (1917), the elections, legal disparities and restrictions on the implementation of decisions, orders and decrees issued by the Central-Provisional Government in Turkestan. Although the interim government's policy included decrees to abolish "religious, national restrictions", this was not reflected in the Turkestan context, legally, and in practice.

REFERENCES

1. *Uzbekistan History, first part. 1917-1939. Tashkent: Uzbekistan, 2019. P.24.*
2. *Turkestan at the beginning of the twentieth century: to the history of the expiration of national independence. : "Sharq", 2000. Pp. 19-22.*
3. *Rasulov. A, Isoqboev. A, Nasretdinova. D. Tatars in the socio-political and cultural life of Turkestan. Tashkent: "TURON-IQBOL", 2019, Pp.11-13.*
4. *Mingnarov A. Coverage of socio-political processes in Turkestan in the national press. (1917-1918) Tashken: "Istiqlol nuri", 2013, Pp.36-37.*
5. *Karimov U. et al. USING NEW INFORMATION TECHNOLOGIES IN DISTANCE LEARNING SYSTEM //НОВАЯ ПРОМЫШЛЕННАЯ РЕВОЛЮЦИЯ В ЗЕРКАЛЕ СОВРЕМЕННОЙ НАУКИ. – 2018. – С. 9-11.*
6. *Vutaboev M. T., Karimov U. U. «ЗЕЛЁНАЯ ЭКОНОМИКА». МИРОВОЙ ОПЫТ И ОСОБЕННОСТИ РАЗВИТИЯ В УЗБЕКИСТАНЕ //Theoretical & Applied Science. – 2020. – №. 2. – С. 704-710.*



COMPARISON OF THE GRAMMATICAL CATEGORY OF GENDER IN RUSSIAN AND GERMAN

Soliev Rakhimjon Ibrokhimovich

Teacher,

Mamasoliev Rustamjon Adxamjonovich

Teacher,

Abdurazzakov Yusufjon Usmoilovich

Teacher, Fergana state university, Uzbekistan, Fergana city

СРАВНЕНИЕ ГРАММАТИЧЕСКОЙ КАТЕГОРИИ РОДА В РУССКОМ И НЕМЕЦКОМ ЯЗЫКАХ

**Солиев Рахимжон Иброхимович, преподаватель,
Мамасолиев Рустамжон Адхамжонович, преподаватель,
Абдураззаков Юсуфжон Усмоилович, преподаватель,
Ферганский государственный университет,
Узбекистан, г.Фергана**

АННОТАЦИЯ: Статья на тему «Сравнение грамматической категории рода в русском и немецком языках» освещает сравнение грамматической категории рода двух языков, которая является особенно важной чертой грамматического строя этих языков. Хотя эти языки имеют сходства в категории рода, имеют существенные различия.

Авторы в своей работе осуществили подробный анализ этих различий. Указывается и объясняются такие понятия, как оппозиция женского и мужского рода в сфере одушевленных, система словопроизводства русского и немецкого языка.

Источники, цитируемые в рецензируемой статье, отражают современную точку зрения на исследуемую проблему.

Полагается, что рецензируемая статья заслуживает публикации в научном издании.

КЛЮЧЕВЫЕ СЛОВА: грамматика, русский язык, немецкий язык, инновация, оформления, преподаватель, образования.



ВВЕДЕНИЕ

Категория рода – одна из центральных в грамматическом строе языка. Она является характерной чертой грамматического строя практически всех индоевропейских языков.

Русский и немецкий языки обнаруживают значительные сходства в плане функционирования и выражения категории рода: все существительные обоих языков (за исключением *Pluralia tantum*), обязательно выступают как слово того или иного рода – мужского, женского или среднего: ни одно имя существительное в единственном числе, даже только что заимствованное из другого языка и имеющее в своей фонетической и структурно – грамматической характеристике чуждые русскому или немецкому языку черты, не может быть вне категории рода. Одушевленные существительные обоих языков характеризуются наличием лексических коррелятов, основанных на противопоставлении существительных по родовому признаку и семантике пола. Как в русском, так и в немецком языках мужской род является не только показателем мужского пола, но и лица вообще. Оппозиция мужского и женского рода в сфере одушевленных существительных может быть охарактеризована как привативная оппозиция с немаркированным мужским родом, который выступает в позиции нейтрализации, обладает большей морфологической регулярностью и частотностью.

При значительных сходствах в категории рода русского и немецкого языков имеются также существенные различия: в группу одушевленных в русском языке входят в основном имена существительные мужского и женского рода, и лишь немногие слова среднего рода. В современном немецком языке наряду со словами, мужского и женского родов, в группу одушевленных входит значительное количество существительных среднего рода. Они обозначают как лица, так и животных. В немецком языке имеется перевес грамматически явлений над семантикой одушевленных имен существительных, т.е. игнорирование естественно-половых различий живых существ, например: *das Mädchen*. Этим объясняется немотивированность родовой принадлежности. В обоих языках существительные, обозначающие один и тот же предмет, могут относиться к разным родам, например: дом(*das Haus*),нога(*der Fuß*), кровать (*das Bett*).

В немецком языке род имен существительных выражается менее последовательно, чем в русском: в современном русском языке род, прежде всего, определяется

по окончанием, в немецком языке – крайне редко по окончаниям. Здесь за каждым существительным закреплен грамматический член – артикль, не имеющий самостоятельного смыслового значения и выражающий грамматический род существительного.

Категория грамматического рода в обоих языках демонстрирует тесную связь между категориальными родовыми формами и словообразовательными моделями, с системой русского и немецкого словопроизводства, однако, русский язык располагает более развитой системой родовых суффиксов, чем немецкий. Наиболее показательным примером здесь является наличие в русском языке большого числа уменьшительно-ласкательных и других эмоционально-окрашенных суффиксов, они образуют слова всех трех родов. В немецком языке есть только два продуктивных суффикса субъективной оценки, оба они образуют существительные среднего рода, даже присоединяясь к основам существительных мужского и женского рода. Наибольшее же сходство исследуемые языки обнаруживают в типе суффиксальных существительных, образованных от иностранных корней с помощью суффикса *-ist*.

Наибольшее различие в категории рода в русском и немецком языках наблюдается в содержании и функционировании среднего рода. Круг значений имен существительных среднего рода в русском языке очерчен менее резко, чем мужского и женского. В немецком же языке подавляющее большинство слов среднего рода имеет вполне определенное значение. Большинство имен существительных среднего рода в русском языке имеет абстрактное значение, а в немецком имена существительные среднего рода имеют собирательное значение. В русском языке средний род обладает по сравнению с мужским и женским родом менее развитой системой продуктивных суффиксов, и средства его выражения относительно бедны. В немецком языке средства оформления и выражения среднего рода более многообразны.

Существенным различием в функционировании категории рода в двух языках является также меньшая, по сравнению с немецким языком, зависимость родовой принадлежности имен существительных русского языка от его грамматической системы. На синхроническом уровне немецкого языка четко прослеживается неразрывная связь между грамматической системой существительных и их родовой принадлежностью. Исходя из словообразовательного типа, три немецкие



категориальные формы рода- мужской, женский и средний – выполняют определенные семантические функции различного типа. Мужской род обозначает главным образом лица и определенные предметы, женский – абстрактные понятия, средний – собирательные значения и слова с качественной оценкой.

Данные языки обнаруживают различную степень зависимости родовой принадлежности существительных от их лексического значения. В современном немецком языке наблюдается определенная последовательность в классификации имен существительных внутри одной родовой группы. В русском языке подобная зависимость прослеживается в меньшей степени.

Наличие значительного сходства в функционировании категории рода в русском и немецком языках обусловлено принадлежностью обоих языков к индоевропейской семье. Однако последовательное сохранение трехчленной структуры рода противопоставляет немецкий и русский языки многим другим индоевропейским языкам, где может быть представлена двучленная родовая оппозиция за счет устранения среднего рода.

В развитии категории рода в сравниваемых языках наблюдаются похожие и различные тенденции, которые можно проследить на материале новых заимствований. В русском языке род заимствованных существительных в большинстве случаев определяется по их форме. Существительные типа холдинг, альянс, фитнес, совпадающие по форме с исконно русскими или уже ассимилированными в языке существительными мужского рода, принимают эту грамматическую форму. Анализ родовой принадлежности немецких заимствованных существительных, выявляют этот путь адаптации как один из возможных. Около половины заимствованных существительных получают род, который имеют немецкие слова с подобным значением, например: das Center = das Zentrum, das Internet = das Netz. Грамматический род других заимствований определяется их принадлежностью к некоторым семантическим группам. Например: средний род получают существительные со значением процесса и существительные, обозначающие некоторые технические новинки, у которых отсутствует аналогия с немецкими словами, например: das Fax, das Display, das Modem. Многие из приведенных слов вошли и в русский язык, но получили в нем в соответствие с их формой мужской род, например: факс, дисплей, модем.

Женский род получают в немецком языке многие существительные со значением, имеющим отношение к компьютеру: die Mouse, die Server, die Site, die Online, die Power, die Disk. Некоторые из них вошли в русский язык как существительные мужского рода: диск, сервер, сайт. В немецком языке мужской род получают, как правило, слова со значением деятеля, например: der Broker, der Dealer, der Lover. В русском языке иногда прибегают к аналитическому способу выражения рода. Это происходит, например, в тех случаях, когда отсутствует коррелят женского рода к соответствующему существительному мужского рода: Декан сказала. Немецкий и русский языки сближает тенденция к изменению структуры рода, а именно развитию коррелятивных форм женского рода к существительным мужского рода, обозначающих лиц по профессии.

Использованная литература

1. Анохина С.П. Сравнительная типология немецкого и русского языков; учеб. пособие/ С. П.Анохина, О.А.Кострова; под общ. ред. О.А.Костровой – М. ФЛИНТА: Наука, 2012.
2. Зеленский А.Л., Монахов П.Ф. Сравнительная типология немецкого и русского языков – М.: Просвещение, 1983.
3. Нецкертова Т.Т. Сопоставительная типология грамматической категории рода в русском и немецком языках – М., 2006.
4. Константинова Л.А. и др. Грамматика русского языка. Часть 1. Учебное пособие по русскому языку для студентов. Тула: Изд-во ТулГУ, 2007.
5. Кадилов Ш. Педагогика. Ташкент, 2009.
6. Векиин Н.Л. Грамматика русского языка. Учебное пособие. М.: АСТ-пресс-школа, 2003.
7. Karimov U. et al. USING NEW INFORMATION TECHNOLOGIES IN DISTANCE LEARNING SYSTEM //НОВАЯ ПРОМЫШЛЕННАЯ РЕВОЛЮЦИЯ В ЗЕРКАЛЕ СОВРЕМЕННОЙ НАУКИ. – 2018. – С. 9-11.
8. Butaboev M. T., Karimov U. U. «ЗЕЛЁНАЯ ЭКОНОМИКА». МИРОВОЙ ОПЫТ И ОСОБЕННОСТИ РАЗВИТИЯ В УЗБЕКИСТАНЕ //Theoretical & Applied Science. – 2020. – №. 2. – С. 704-710.



MORAL HERITAGE AS AN INTEGRAL PART OF SPIRITUAL HERITAGE

Normatova Dildor

Lecturer, Fergana State University, Uzbekistan, Fergana City

ANNOTATION

The article deals with the moral heritage as a part of the spiritual heritage of its social and human aspects of enlightenment.

KEYWORDS: *moral, moral heritage, universal, culture, ideal person, values, justice, behavior.*

INTRODUCTION

The victorious path of Uzbekistan in the years of independence, its incomparable achievements is the result of creativity of our nation. This historical fact has been repeatedly repeated by the First President of the Republic Islam Karimov in his works, speeches and meetings. *"It is gratifying to note that virtues and aspirations are ingrained in the blood and bones of our people,"* suggests the President[1]. *"Despite all the invasions and difficult situation, our ancestors did not lose their identity, followed the criteria of spiritual life, morality and strive for perfection"[2].*

The high spirituality and moral standards of our people are embodied in their moral heritage, imbued with a very rich humanity, life experience and deep philosophical thinking. Historical memory has become a source of education and an example of how the formation of a harmoniously developed personality raised not only the main task of spiritual and educational work, but also the level of public policy, which makes it relevant. To study our moral heritage, its sources and philosophically analyze them, to convey to the harmoniously developed generation that morality has always been the core of spirituality, intelligence and lifestyle of our people. Explanation, based on the immortal philosophical heritage, is one of the important themes in the history of philosophy. Indeed, as researchers note, it is difficult to find any naturalist, philosopher, artist, historian, poet, or literary critic in the history of Central Asia who does not address moral issues in his works and philosophical treatises.

The moral heritage has always reflected all the changes and contradictions inherent in society. The

moral heritage is the simple or everyday rules of public life that have been formed and formed over thousands of years. It did not pass from one social system to another in "pure" form. Some of them showed that they cannot live in new conditions. Others, in their turn, played a negative role. While some of them lost their essence and content over time, others were transformed and improved under the influence of the spirit of time, enriching a solid treasury of spiritual and cultural heritage of the people.

When thinking about the essence and content of the concept of moral heritage, attention is always paid to the extent to which it reflects the spiritual needs, demands, desires, wishes of social groups that exist in this or that society. It also draws attention to the purpose for which these concepts are relevant in terms of their content and essence. These purposeful concepts, in turn, are not dogmatic in nature, but are inextricably linked to the spiritual development of society, which is passed from generation to generation as a moral heritage.

Moral heritage is a set of positive models of behavior that can serve as a model for society, time, and human history; A spiritual phenomenon that determines and evaluates the level of maturity of man. Moral heritage is an integral part of the spiritual heritage of mankind. It is a set of all moral acts inherited from previous generations, which are evaluated and used on the basis of critical approach, revision, specific tasks of time and objective criteria of social development.

Academician I.Muminov writes *"The roots of the moral heritage have a very long history going back to Avesta in the East. The Avesta clearly*



reflects the essence and content of human moral values. Undoubtedly, the Avesta is an invaluable source for studying the history of formation and development of morality of Central Asian peoples"[3].

It condemns selfishness, jealousy, arrogance, corruption, theft, robbery, theft, betrayal, obscenity, impartiality, mutual respect, love and affection, land, water, fire, air. Spiritual and moral values, such as respect, are glorified. Avesta" is the great philosophical, spiritual and moral heritage of humanity, especially for the Uzbek people. The principle of continuity is important in the correct interpretation of the moral heritage, moral development in general. Inheritance in the development of morality means, first of all, the correct use of the riches preserved from the past in the field of morality, their deep and rational study. Obviously, the question of inheritance in the field of moral heritage should also be treated seriously and with caution.

When reflecting on the moral heritage of heritage, special attention is paid to the past of the peoples of the East, oral and written monuments passed down to us by our ancestors as a cultural and moral heritage, especially Avesta, and the moral qualities of man described in it. *"Development of moral thought in the land of old Turan and Iran is connected to the appearance of Zoroastrianism. The holy book of this religion, which began to be written about 30 centuries ago, called "Avesta" in ancient Khorezm, lists and interprets the main moral qualities"*[4]. The Arab invasion, although aimed at the interests of the invasion, but its consequences were later positive. The Arab invaders burned cultural treasures, writing and books created by the locals, as noted by Abu Rayhan al- Biruni. At the same time, they served as a bridge to harmonizing Eastern and Western cultures.

In the so-called Renaissance of 9th-15th centuries there were great social changes in public life of the Central Asian region. There were positive changes in a cultural life. Culture and its features were formed. By this time, firstly, the aspiration to secular and religious enlightenment, wide use of cultural achievements of the past and neighboring countries, secondly, the interest to nature, belief in reason, truth as a basis of human science, thirdly, great blessing of nature, substantiation of natural, art, spiritual qualities, demonstration of humanity, high moral laws and rules directed on education of the perfect man became important aspects of culture of this period.

The culture of this period has served the development of human qualities. The culture serving universal qualities is hereditary. Morality is an integral part of the inherited culture. It follows that

when thinking about the content and essence of morality and ethical heritage, one should pay attention to the signs of its inheritance. Therefore, it is important to pay attention to the moral heritage of medieval Central Asian thinkers, their teachings on the content and essence of morality, as in this period Central Asian thinkers had comprehensive encyclopedic knowledge. As naturalists, musicologists, mathematicians, astronomers, geographers, writers, poets, literary critics, philosophers, they also paid special attention to ethical issues in their works and advanced moral ideas that meet the requirements of the time.

Central Asian thinkers, first of all, respected the cultural heritage and morals of Ancient Greece, India, Egypt, Iran and Arab countries and developed them creatively. Secondly, they themselves created original works and laid the foundation for advanced moral teachings. In the context of these teachings, the human personality, its best qualities were elevated to great heights, science was valued, values based on man and humanity were highly appreciated. From this point of view, the philosophical views and teachings of medieval Central Asian thinkers as Abu Nasr Al-Farabi, Abu Rayhan al-Biruni, Avicenna, Ahmad Yasawi, Najm al-Din Kubra, Baha-ud-Din Naqshbandi, Abd al-Rahman Jami, Ali-Shir Nava'i, and others are about the spiritual and moral development of the personality are of particular importance.

According to political scientist N.Dzhurayev, *"self-consciousness begins, first of all, with the study of the past, with the need to know history"*. In addition, he aims to know what they did and how they lived. N.Dzhurayev also adds: *"In this sense, it is important to study the moral heritage of our people, to conduct scientific and theoretical analysis, to transfer and absorb it into the minds and hearts of young people. The first President I.A.Karimov highlighted that self-awareness begins with acquaintance with history"*[5]. It is known that in the historical development of society, human values are not just a set of abstract concepts, but they emerged and developed in close connection with concrete reality and philosophy of life as a product of the requirements of certain social and historical conditions. The most important and significant page of the philosophy of history is the spiritual and moral heritage.

Morality is an integral part of the society's spiritual heritage. It cannot be studied in isolation from the spiritual heritage of humanity. It is enriched in the process of studying nature, social environment, various human relationships, knowledge about the existing phenomenon, the constant desire to change it, leading to the enrichment of human spiritual qualities. Not only today it is formed on the basis of



centuries-old spiritual heritage and develops in the process of continuous cultural relations with other peoples, mutual exchange of spiritual and philosophical values. After all, history is a product of thinking.

Every event in our past was influenced by a certain spiritual, moral, socio-political environment. In the course of this study the task was set to shed light on this historical fact, to bring our rich moral heritage to the consciousness and consciousness of people, and at the same time wisely solve such philosophical problems as thinking, understanding the past and choosing the future. The solution to this problem is based on the historical and philosophical heritage of our great ancestors. It is no secret that the philosophical and moral heritage of Central Asian thinkers is based on man and his essence, human values, justice, loyalty, duty, loyalty and kindness. It develops inextricably with the social and economic, political conditions, lifestyle and spiritual development of society and is an assumed barometer that defines the level of spiritual development of peoples, nations and nations in society. Morality is an event that evaluates the level and scale of historical development of society, as well as the society and people functioning in a particular social environment. Morality, which evaluates members of society, has a relative character, develops and changes in an inseparable connection with the social life.

Overall, morality is not only a social phenomenon that evaluates members of society, but also includes the differences, scales, level of one stage of social life in another, as well as classes in a particular society, the morality of social groups and, finally, the inheritance of moral heritage. In this sense, it is important to study the moral heritage of our people, conduct scientific and theoretical analysis, transfer and absorb it into the minds and hearts of young people.

Morality is an integral part of the society's spiritual heritage. It cannot be studied in isolation from the spiritual heritage of humanity. It is enriched in the process of studying nature, social environment, various human relationships, and knowledge of the existing phenomenon, constant striving to change it, leading to the enrichment of human spiritual qualities. Not only today it is formed on the basis of centuries-old spiritual heritage and develops in the process of continuous cultural relations with other peoples, mutual exchange of spiritual and philosophical values. After all, history is a product of thinking.

Every event in our past took place under the influence of a certain spiritual, spiritual, moral, socio-political environment. In the course of this research the task was set to shed light on this historical fact, to bring our rich moral heritage to the consciousness

and consciousness of people, as well as to wisely solve philosophical problems such as thinking about them, understanding the past and choosing the future. The solution to this problem is based on the historical and philosophical heritage of our great ancestors. It is no secret that the philosophical and moral heritage of Central Asian thinkers is based on man and his essence, human values, justice, loyalty, duty, loyalty and kindness. It develops inextricably with the social and economic, political conditions, lifestyle and spiritual development of society and is an assumed barometer that defines the level of spiritual development of peoples, nations and nations in a society.

CONCLUSION

Indeed, morality and social development are separate concepts. In fact, morality is part of social development. The level and scale of historical development of society, as well as the society existing in a particular social environment, and people who function, are value ethical norms. The morality that evaluates the members of society is relative, develops and changes in an integral connection with social life. Morality is not only a social phenomenon that evaluates members of society, but also includes the differences, scales, level of one stage of social life in relation to another, as well as the morality of classes, social groups in a certain society and, finally, the hereditary nature of moral heritage. This embodiment is reflected in social development.

REFERENCES

1. Каримов И.А. *Ўзбекистоннинг сиёсий, ижтимоий ва иқтисодий истиқболнинг асосий тамойиллари*. -Тошкент: 1995. – р. 53.
2. Аликулов Х. А. *Этические воззрения мыслителей Средней Азии и Хорасана*. - Ташкент: Фан, 1992. –р.3.
3. Мўминов И. *Избр. произ., т. 3.*- Ташкент: Фан, 1972, р.110
4. Абдулла Шер. *"Ахлоқшунослик"* . -Тошкент: "Янги аср авлоди", 2003. – р.24.
5. Жўраев Н. *Тарих фалсафаси*. Тошкент: Маънавият, 1999. –р.19 .
6. Норматова Д. *Монография. Ахлоқий меросда миллийлик ва умумбашиарийлик диалектикаси*. Фаргона. 2016.
7. Эркаев А. *Тафаккур эркинлиги*. Тошкент, 2007.
8. Саифназаров И. и др. *Философия. Курс лекции*. Ташкент, 2003.
9. Зиёмухаммадов Б. *Экология ва маънавият*. Тошкент, 1997.
10. Жалилов А. *ва бошқалар. Фуқаролик жамияти асослари. Ўқув қўлланма*. Тошкент. Vaktria press. 2015.



11. Жалилов Ш. Кучли давлатдан - кучли жамият сари: Тажриба, таҳлил, амалиёт. Тошкент, "Ўзбекистон", 2001.
12. Шарифходжаев М. Формирование основ гражданского общества в Узбекистане / Отв. ред. А.Х.Саидов– Т.: Мир экономики и права, 2002.
13. Сорокин П.А. Человек. Цивилизация. Общество. / Пер. с англ. М.: Политиздат, 1992.



ARTISTIC AESTHETIC FUNCTION OF LETTERS IN THE NOVEL “PAST DAYS”

Xasanova Xikmatoy

Lecturer at the Department of Literature at Fergana State University

ANNOTATION

This article analyzes the role of Abdulla Kadiri in the composition of the letters in the novel "Past Days". The importances of the letters are shown in elevating the characters to the main level in the work.

KEYWORDS: *letter, place, tense, syujet, diplomatic letter, loving letter, detal, solution, hero portrait, konflikt, solution, conclusion.*

DISCUSSION

After listening the quotes like "It's good to work with going back to history", "- You are that - I am that" there is no one who does not remember Abdulla Kadiri, the founder of Uzbek romance, who does not think about of the “Past days”, who does not think about of Otabek and Kumush. This novel, which has reached the forefront in Uzbek literature of the 20th century, will be the subject of a number of debates and new researches among all literary critics. This novel, which has reached the forefront in Uzbek literature of the 20th century, will be the subject of a number of debates and new researches among all literary critics. Based on this, we have tried to approach the letters in the work in terms of their role and the artistic significance of the letters. Each creator uses different means to reveal the spirit and idea of his work. Some use dreams, some dreams, some images of nature, some use letters. The letter is a detail that, in the days of the past, combines changes in the psyche's moods with changes in social and political systems, helping to increase the artistic value and spiritual impact of the work.

Different themes are dominated by the letters in the work. We have categorized letters in our work into four content groups: romantic letters, family letters, diplomatic letters, and social letters. Also, in this work, each species is presented to us with its own specifics. The letter of Yusufbek Haji to Otabek, which appeared early in the book, appears as the first letter expressing family relations and the socio-political environment - the collapse of the period. We can say that this letter is the solution to the first social conflict in the work - Otabek and

Mirzakarim kutidor save from the perpetrator's death. Kumush will carry the letter to Utabboy Governor. Days later, a second letter of dissenting against the siege of Tashkent due to the revolt of the Musulmonkul, Yusufbek Haji and Azizbeks appeared on the surface. Homid tried to hide and conceal himself by sending a letter to Khudoyarkhan, a rebellious son, "biting" in Margilan. As a result, Muslimkul ordered Utabbay to bring Otabek to the Khan's palace and treated him as such.

The letter that saved Otabek's fate from death was the letter, and now it is the letter that once again put him to death, a provocative letter from Hamid to the khan. Nevertheless, the letter, which led to the second major turning point in the work - which saved Otabek from his second death, will also be a letter. This letter was just one example of a diplomatic letter from Tashkent that Normuhammad kushbegi, with the assistance of Yusufbek Haji, was taken from Tashkent. There is also a small request from Yusufbek Haji - another petition sent by Normuhammad to the Khan's palace with the help of Hasanali to save his son, who was innocent in Margilan prison, saved Otabek from death. Although the letter was not sent by Yusufbek Haji, Otabek showed his father's mental state and caused him to go to Tashkent. As a result, Otabek faced a "parenting dream" in Tashkent. Of course, we can say that the three letters that came up in the first chapter of the book not only represent changes in the psychology of images, but also connect the spaces in which the events take place.

The problem posed in Chapter II of the work is the realization of the "dream of parents" and relies



on the writer's letter to describe the changes in the mood of Otabek, who has not been able to solve this problem, and the attitudes of Mirzakarim kutidor. This letter was unusual. The letter, which had not yet been met, was a problematic letter sent by Yusufbek Haji to Mirzakarim kutidor.

The purpose of the letter is to return Father to Tashkent; to marry and touch his step from Margilan. The reason for this goal is the "lonely hoof" of both families. The compromise was to reconcile by getting another bride to them without separating the gods from Kumush. This letter of his father is like bringing him back to the gallows with his dignity, his pride and the public. However, Kutidor takes his son-in-law to Tashkent to avoid interference with Otabek and his cousins, and he returns to Margilan alone after the wedding. The reason why the silver-letter was sent to Otabek, who was unable to come to Margilan because of the illness of his second brother-in-law after the wedding, was sent to Kumush, who was upset. Words and bytes in this letter affect Otabek and leave him, until he arrives at Margilan, forcing his enemies to divide them, separating them even their beloved parents and sons. This is due to a fake divorce letter "Homid" (created for speech and works), dated 13th 1212 AH from Otabek. As a result, at the moment when Otabek was hurrying out of the hijra, he was being blown out of the house by which he was being accused of "insidious", "dishonest", "a foolish husband" and "God forbid that he should die". The reason for this is that Otabek is indifferent to the possible Margilan enemies. As a result, the letter with the shedding of hands without interrogating the identity of Otabek and Hasanali would fall into the hands of his fierce opponent, Hamid, not Kumush. A romantic letter written in response to a letter of silver's tender embarrassment and insidious jealousy reaches its owner with a very different look and thought and "The 26th of December, 1265 AH, will be a letter from Tashkent, [Abdulla Kadiri, Selected Works, Tashkent "Sharq", 2014. p]" which once again honored Altinbibi's reputation.

This letter was replaced by a second fake letter to a 5-6-word letter containing a cruel word, and was destroyed. Homid not only alters the contents of this Safari letter, as he says, "The robber takes care of himself every time," and sends a message to Paradise Auntie, who benefits himself. Mirzakarim kutidor, angered by the fact that this happened to his only daughter, had an impact on the desperate Otabek. Takedown of the box, which is greeted by the words "Do not stop at my door", Otabek guides her in the Margilan evening. Just as there is wisdom in everything, this home, which he visits as a stranger, provides a solution to all the problems associated with it. But before he could show himself, he had forced Otabek to hear how silly

it was to be "expelled" and "divorced." Otabek did not find his fault despite all the deliberations. There is wandering between Tashkent and Margilan. Until he was able to spend the night in the Khoja Maoz cemetery and be able to look at the problem, he would talk to the master Farpi in the House of Scientist and hear the scorn of Otabek (his own) until it became clear that this was the way to go. Now Otabek is thinking of how to respond to this terrible enemy, who has been poisoned by his past, defeats his enemies and ends the lives of fake letter-makers. To justify the dramatic changes in the plot of the work, his brother-in-law Mirzakarim wrote a letter to the boxer (the letters between the father-in-law and the groom are not displayed in other works) and Silver. The letter expresses her feelings and psychological state of events. Most importantly, it was appropriate to point out that the letters found in the composition were the basis for the typeface of the Otabek and Kumush characters before they were handed over to the Master, the Master.

Diplomatic letters found in section III of the novel also found their place in the story. They also feature the features of diplomatic letters that appear in them. For example, we see that the words they use are the highest examples of artistic style. "*Shah Haqan, horn of honor to the crown, to the noble of nobles ...*" As you can see in the composition of the work, it serves as a means of linking space in the form of the book: Diplomatic letters appearing in the "past days" and other works contain political correspondence. We can say that such political correspondence is the basis of diplomatic relations.

In Section III, along with political correspondence, there are also romantic letters. These letters reveal to the reader their inner experiences of the social changes in the lives of the heroes of the work and the psychological state of these changes. We can see this in the letter: "*Moonlight my wife, my housekeeper, Silver,*" and, "*The horrible truth of your love, shakes like a leaf, He would have gone astray ...*" "*... I felt an unexpected force in me, and I had the power to alternate between two and two hundred enemies ... my own source of strength. I knew very well that this source of change in me was a sleeping angel... You were!*" [Abdulla Kadiri, Selected Works, Tashkent, "Sharq", 2014, 212 pages]. In response to the above words found in Section II, the following letter from Silver quotes the following words: "*From the name of Zulaykho, Joseph, who was unstable in the trade, the greeting of Leyli, who had been in love with Majnun,*" "*... Unhappy like me, if you have a lot of confusion and frustration with me, you may have run away ...*" "*I'm always in danger. If I could just sit at your door with God, I would know my fat ...*" [Abdulla Kadiri, Selected Works, Tashkent, "Sharq", 2014, 239 pages] The letter describes the inner mood and inner feelings of the Father who received this



letter, which makes the reader feel like he is reading. Generally, each letter in the work describes heroes and social change in society, and has been used as a link between two spaces in the development of events from one space to another. In addition to the letters above, this chapter also contains a letter describing family relationships. This is a letter to Kumush's mother. In it, Kumush reports his condition in Tashkent. At the end of his letter, Otabek expressed his sorrow over the death of his grandmother, and if not worse, his family's affection for his mother-in-law and his intolerance with his partner and other friends. I wrote to Kumush. Tashkent, in the 1st bracket of 1269. ” In this we can see that Kumush had foreseen the tragic fate of his division, or that the writer made a small hint of his tragic fate. The letter below sums up Dad's fate. The letter was said to have been sent to Yusufbek Haji in 1277 from the Wing of Father Saint. “*Your son, Otabek, was with our neighbor. These two guys took the first place in our fight with the Russian over Almata. He was a heroic martyr and I buried two with my own hand. Will decide the fate of Otabek*”.

Thus, we can conclude that the romantic letters of Abdullah Kadiri in the "Past Days" will not only serve to convey the hero's mental state, but also enrich the hero's portrait.

The letters expressing family relationships in the work served to provide a clear picture of the relationship of the characters, while the writer was an important tool in creating a family image. He has also been able to incorporate the types of letters that are rare or not seen in the works. For example, a letter between kudos and a letter from a son-in-law.

All the letters of the century serve as the main link between polyphonic spaces. In particular, there are such places as Yusufbek Haji house, Mirzakarim kutidor house, Tashkent beks palace, Kokand khan's palace, Margilan station. In conclusion, it is noteworthy that the letters of Abdullah Kadiri in his book "The Past" serve not only to enrich the greatness of the soul, but also to give the reader the name of the work, the heroes of the work, and give the reader an artistic aesthetic pleasure.

REFERENCES

1. A.Qodiriy. *Tanlangan asarlar, Toshkent, "Sharq", 2014.*
2. D Quronov. *Adabiyotshunoslikka kirish. – Toshkent: "Fan", 2007*
3. I.Sulton. *Adabiyot nazariyasi. - Toshkent: O'qituvchi. , 1980*
4. T.Boboyev. *Adabiyotshunoslik asoslari. –T.: O'zbekiston, 2002.*
5. *Ozod vatan saodati. 5-jild. Adabiy tanqid. -Toshkent "ADIB". 2013.*
6. *Xudoyberdiyev Э. Адабиётшуносликка кириши. –Ташкент: "Шарқ", 2008.*
7. *А.Қодирий. "Ўткан кунлар"да баъзи изоҳлар. "Шарқ ҳақиқати", 218-сон.*
8. *Karimov U. et al. USING NEW INFORMATION TECHNOLOGIES IN DISTANCE LEARNING SYSTEM //НОВАЯ ПРОМЫШЛЕННАЯ РЕВОЛЮЦИЯ В ЗЕРКАЛЕ СОВРЕМЕННОЙ НАУКИ. – 2018. – С. 9-11.*
9. *Butaboev M. T., Karimov U. U. «ЗЕЛЁНАЯ ЭКОНОМИКА». МИРОВОЙ ОПЫТ И ОСОБЕННОСТИ РАЗВИТИЯ В УЗБЕКИСТАНЕ //Theoretical & Applied Science. – 2020. – №. 2. – С. 704-710.*



INFLUENCE OF GEOIDEOLOGICAL PROCESSES ON INTERETHNIC RELATIONS

Olimova Mohinur Ravshanbek qizi

Teacher

Jamalova Nargiza Ulugbek qizi

Teacher, National University of Uzbekistan

ANNOTATION

In the processes of globalisation, the power of geoideological processes to influence interethnic relations, the disagreement between nations, races in society, the origin of conjunctions, the negative consequences of the ideas of fascism, chauvinism, racism, nationalism are revealed.

KEYWORDS: *society, nationality, globalism, geoideology, tolerance, chauvinism, racism.*

DISCUSSION

In the course of the global process, when it comes to geopolitical goals and interests, first of all, if we look at its history, Aristotle believes that in the life of Man and society, the geographic environment of a certain region affects its geoideology processes. Ibn Khaldun also refers to those activities in the works, views on the magnitude of the role of science in the development of the state, concerning the absence in science in cold climates countries. At present, the ideas of ideological fascism, racism, chauvinism serve the geoideology interests. Under the influence of such negative ideas, it leads to the destruction of the nation, its impasse. The decrease in the human factor causes a decrease in human value.

Security remains the most pressing issue today. As long as there are nations, there will also be mutual relations between them. The most dangerous obstacle to the realization of the idea of national harmony is aggressive nationalism and chauvinism. The current conflict seems to be connected with the problems within the state, not the state itself. The fact is that the conjugates, which seem to be related to the internal problems of the state, have a regional or universal character. Because the activity of forces that characterize the resistance of dependence is associated with external factors. This is because it is inextricably linked with the processes of globalisation that are entering the society significantly. Globalisation has not taken on itself the reduction of compression and taxidermy, which has a

present and potential outlook in society. On the contrary, "globalisation is concerned about the resumption of the ongoing opposition from joining new ones in the ranks of universal risks in new ways"[1]. Globalism is an analysis of inter-civilization relations in an ever-changing society, from the consequences of the weakening of national values that form the basis of civilizations to human beings. In such circumstances, it is imperative for nations to remain faithful to their national values and strive to enrich them, as well as to make practical efforts to preserve their national traditions in the realization of the identity of nations and nationalities. The struggle of states against any manifestations of nationalism and universal values in the conditions of globalism, the preservation and development of national values, creates the need for a regular struggle in order not to fall into the sphere of influence of geomaphoric forces in society.

In this regard, since the early years of independence, Uzbekistan has developed and implemented the concept of national development of Uzbekistan. The prosperity of society in the period of the Geospatial struggle dictates the improvement of solidarity and national idea among the national and ethnic groups in the state. Now in Uzbekistan a great deal of trust is paid to the relations of nationalities and mutual friendship. In 2017-2021 "Strategy of actions" was developed in five priority areas of further development of Uzbekistan. The 5th priority direction of the strategy of action is aimed at



"ensuring the security of the nation's unity and religious tolerance, maintaining a deeply thought-out, mutually beneficial and practical foreign policy". The main purpose of this project is to ensure information security and improve the information protection system, to provide timely and appropriate resistance to the threats in the information sector, and to strengthen the civil, national and inter-confessional peace and harmony. According to this, the decree of the president of the Republic of Uzbekistan "On measures for further improvement of national relations and friendly relations with foreign countries"[2] was adopted.

It is known that on our ancient and generous land for many centuries representatives of different nationalities and cultures and religions have lived peacefully. Hospitality, kindness, heart and literal tolerance are the basis of its mentality, which has always been appropriate to our people[3]. Our past history shows that nobility and humanism, striving for national harmony are one of the highest qualities of our people. I believe that the president of our autonomous Republic Shavkat Mirziyoyev, in order to improve the relations of the nation, should once again note that "Uzbekistan is ready to establish and develop open mutually beneficial and close cooperation with the countries of our region. This is one of the main directions of our foreign policy" [4].

First of all, in order not to fall under the influence of geo-ideological ideas, we need to educate our youth with the permission of love and loyalty to the native land, to live as friendly and moral among different nationalities and nationalities living in our country, to achieve further improvement of relations. Since the first years of independence, Islam Karimov, the first president of the Republic of Uzbekistan, has also paid great attention to this issue. Great statehood, hegemonism and aggressive nationalism pose a great danger to society. In this regard, a lot of work is being done even today. After all, in this regard, by degrading other peoples and restricting them their freedom, well-understanding the impossibility of creating prosperity for their own people and nation, we can see that the equality of all citizens in Uzbekistan is also defined in the Constitution of our main encyclopaedia and how much attention is paid to this sphere, one of the basic principles of In order to ensure nation-wide relations in Uzbekistan, Republican international cultural centers have been established, and now 137 national cultural centers operate in Uzbekistan. The fact that festivities are being held in our country under the slogan "Our Common House of Uzbekistan" indicates that peace and harmony between nations is ensured in Uzbekistan. There will be no peace in that land unless there is harmony between nations.

National harmony is one of the priority directions of the state policy of the Republic of Uzbekistan. Ensuring national harmony in society creating an atmosphere of friendship formation of a single family atmosphere of multinational education of young people in the spirit of love and loyalty to the motherland plays an important role.

REFERENCES

1. *Кашлев Ю. На передовом рубеже глобализаций. Международное информационное общество и вызовы дипломату XXI века «Независимая газета». 28.11.2000 г*
2. *www.lex.uz*
3. *2017-2021 йилларда Ўзбекистон Республикасини ривожлантиришнинг бешта устувор йўналиши бўйича Харакатлар стратегиясини "халқ билан мулоқот ва инсон манфаатлари" йилида амалга оширишга оид Давлат дастурини ўрганиш бўйича Илмий-услубий рисола. –Т.: 2017. 358-б*
4. *Мирзиёев Ш.М. Халқимиз розилиги бизнинг фаолиятимизга берилган энг олий баҳодир. - Т.:-2 жилд Ўзбекистон, 2018, 351-б.*
5. *Фарходжонова Н.Ф. МАССОВАЯ КУЛЬТУРА-ДЕСТРУКТОР НАШЕЙ НАЦИОНАЛЬНОЙ КУЛЬТУРЫ //Теория и практика современной науки. – 2017. – №. 4. – С. 11-14.*
6. *Ergashev I., Farxodjonova N. Integration of national culture in the process of globalization //Journal of Critical Reviews. – 2020. – Т. 7. – №. 2. – С. 477-479.*
7. *Farxodjonqizi F. N., Dilshodjonugli N. S. Innovative processes and trends in the educational process in Uzbekistan //ACADEMICIA: An International Multidisciplinary Research Journal. – 2020. – Т. 10. – №. 4. – С. 621-626.*
8. *Numonjonov S. D. Innovative methods of professional training //ISJ Theoretical & Applied Science, 01 (81). – 2020. – С. 747-750.*



MIGRATION FACTORS OF A WORK OF ART

Nishanov Yashin

Senior Lecturer at the Department of Russian Language, Ferghana State University

ABSTRACT

The article analyses the factors of the emergence of plot migration in world literature, as well as, particularly in national literature on the example of the fable genre. It also discusses examples of creative interactions and artistic connections.

KEY WORDS AND EXPRESSIONS: *Social progress, the art of words, a migrating plot, national characteristics, environment, ethical and moral characteristics, example, image.*

DISCUSSION

Fiction is a peculiar reflection of human history and social progress. Factors of ancient mythological concepts associated with religious beliefs and views contributed to the appearance of similarities in literary plots, their harmony, and sometimes migration features. The migration of plots can be observed in many folklore samples, as well as in various writing genres. This feature is quite expressed in the genre of fables.

It is assumed that the origin of the form of a fable in ancient Greece dates to the VIII-VI centuries BC. and is associated with the name of Aesop.

But for the most part, the fable remained as an example of oral creativity. Over time, the aspiration of writers and poets to localize and contain a work of art led the genre of fable to a separate written creation. At the initial stage of development, the fable had the function of a preacher, later it was reformed into folklore. In many sources, the emergence of this genre is associated with Greece and India. It is difficult to agree with the assertion that the fable arose on one of the ancient examples of the fable genre, two have survived to us: the stories about Tevkra and Menelaus from Sophocles' "Ayanti".

Over time, the fable went beyond the high standard of creativity and acquired the status of a popular educational didactic literature. Along with this, the fable became a constant companion of mentors and philosophers. So, already in ancient times, the stage of transformation of the oral form of a fable into a written one began. The basnologist M. Gasparov, characterizing the genre of fable, notes

that this is a short story, sometimes in the form of a verse, containing morality and instructions in the final part. In world literature, the oriental fable is of great importance. Written in India in Sanskrit in 3-4 centuries AD "Panchatantra" (Collection of "five books"), reflects human qualities through images of animals.

"Panchatantra" is widespread in the east, attracting creators with its simplicity and clarity of presentation.

It has been translated into Persian, Arabic and other languages. Translations into Persian (6th century AD) and Arabic (8th century AD) are known as an independent work called "Kalila and Dimna". With the translation into Greek in the 11th century the work became widespread in Europe.

Through Byzantium, the Greek translation became known in the countries of Eastern Europe, particularly, in ancient Russia. In the 13th century "Kalila and Dimna" was translated into Spanish and ancient Hebrew, then into Latin and German, and in the 16th century into English and French.

After the Europeans became familiar with Indian fables, they were repeatedly reworked by modern fabulists.

Around 1270, Ivan Kapuansky, the author of the Hebrew version of the Panchatantra translation, translated it into Latin. This translation for Europeans served as a manual for human life, which introduced them to the specifics of Eastern culture. As a result of creative influence, starting from the 16th century, fables on various topics began to be published in Western European languages. The East is the



birthplace of a fable. We can say that the eastern themes migrated to the west, transformed, and over time moved again from west to east. Attention is drawn to the fact that no matter what time the writer creates, life is always reflected in his fables, a critical approach to the nuances, trifles and shortcomings of everyday life is manifested. From the point of view of the topics touched upon in creativity, Aesop's fables can be divided into the following groups:

1. A foolish person will not become smart because the world is ruled by evil, but a smart person can sometimes turn into a fool.

2. Everything comes and goes, and nothing depends on the person.

3. External impression is deceiving. You must be able to see evil under a good impression.

4. Passion is harmful because it blinds a person and makes it impossible to see reality.

5. Be content with what you have and not strive for more.

So, the concept of Aesop's fables is based on 4 cases.

1. Evil rules the world

2. Fate is fickle, external impression is deceiving

3. Everyone should be content with what he has and not strive for excess.

4. Everyone should defend themselves and fight for themselves

Therefore, Aesop's fables are created according to the scheme: "if a person violates one of the conditions in his own interests, the result will be disastrous", for example: "The goose laid one golden egg every day" The owner did not show patience and killed the goose: as a result, he got gutted instead of gold. Or: "One just felt sorry for the frozen snake, warmed it up, she stung him." The migration stories given above in close form can be observed in Uzbek fabulists, for example: one poor man gave breadcrumbs to a mouse, for which a mouse from a hole gave him a gold coin. It seemed not enough for the poor man to receive a gold coin every day. He decided to destroy the mouse hole but found nothing there. Aesop's second thesis can be cited as an example from oral and written sources of the East (for example, the work of Saadi.)

Once a whip fell out of the hands of a blind rider, without waiting for outside help, he started to look for a whip. A coiled snake was laying on the ground. Despite the warning of the watchers, the rider took the snake in his hands, thinking it was a whip, and continued his way. Very soon, the snake stung him to death. As a conclusion, a proverb can be cited: The blind person believes only in what he has taken, the deaf person believes in what he heard: it is obvious that in wandering plots, there are differences, but the motive and ideas are unchanged. According to Aristotle, methods of persuading artistic speech are

of three types. The first is related to the personality and origin of the speaker. The second is speaking, considering the age of the listeners, their level and mood. The third is associated with speech itself and its content. These conclusions of the famous philosopher of antiquity can be applied to the nature of migrating plots, their ideological goals, moral and ethical boundaries.

REFERENCES

1. Б.Зиёмухаммадов. Педагогика. Ўқув қўлланма. Тошкент, 2006 й.
2. А.Эркаев. Тафаккур эркинлиги. Тошкент, 2007 й.
3. М.Кўшжонов. Бадийят қонуниятлари. Тошкент, 1983 й.
4. Н.Шукуров. Услублар ва жанрлар. Тошкент, 1973 й.
5. Х.Умутов. Бадий ижод асослари. Дарслик. Тошкент, 2001 й.
6. Karimov U. et al. USING NEW INFORMATION TECHNOLOGIES IN DISTANCE LEARNING SYSTEM //НОВАЯ ПРОМЫШЛЕННАЯ РЕВОЛЮЦИЯ В ЗЕРКАЛЕ СОВРЕМЕННОЙ НАУКИ. – 2018. – С. 9-11.
7. Vitaboev M. T., Karimov U. U. «ЗЕЛЁНАЯ ЭКОНОМИКА». МИРОВОЙ ОПЫТ И ОСОБЕННОСТИ РАЗВИТИЯ В УЗБЕКИСТАНЕ //Theoretical & Applied Science. – 2020. – №. 2. – С. 704-710.



FACTORS FOR THE DEVELOPMENT OF INTERCULTURAL COMPETENCIES OF FUTURE TEACHERS

Mahamajonova M.M

Senior Lecturer of Fergana State University

ABSTRACT

The problem of intercultural competence formation is especially relevant for graduate students, as higher education practice shows that students have a high level of communicative competence in learning a foreign language, However, they do not have sufficient intercultural knowledge and intercultural communication skills in most cases. In this article, I will discuss the factors for the development of intercultural competence of future teachers.

KEYWORDS: *Media, culture, competence, modern approaches, factors, education, upbringing, globalization, knowledge, linguistic and cultural information, relationships, human, skills, intercultural communication, foreign language teaching, methodology, development.*

INTRODUCTION

The issue of developing the spiritual and cultural knowledge of our students and their development as a comprehensively competitive staff has been a topical issue in our country. Actually, the development of the state, the future of the young people is determined by the level of spirituality and civilization of its citizens. Therefore, the less attention is paid to the issues of spirituality and culture in a country, the more the future and development of that state will not develop. As the first President of the Republic of Uzbekistan I.A Karimov emphasized that harmoniously developed generation will be the foundation of Uzbekistan's development. Our country pays special attention to improving our spiritual values, the national education system and strengthening its national foundations.

So, the culture of each person is a mirror of his morality, his manners and behavior is determined by feelings of humanity. Morality is formed on the basis of cultural, intellectual, legal, religious, economic and political knowledge. This knowledge allows a person to develop the level and indicators of culture, as well as personal and professional qualities and qualities in them, to have a place and maturity in society as a mature person in the future. Culture is realized under the influence of acquired knowledge, skills and abilities. Culture is a specific member of society and a set of all the positive, intellectual

achievements accumulated in the course of the activities of citizens. It is advisable to pay attention to the wider use of foreign experience in the preparation of creative pedagogical students for intercultural competence. As a result of creativity, communicativeness, cognition of the teacher, students gain a deep knowledge of the history and culture, literature, art, traditions and customs of their ancestors. Through the study of intercultural conflicts, students' interests and potential for interstate cultural heritage increases. We know, a sincere, healthy spiritual environment is created during the lesson. As a result of effective use of sources of spiritual and cultural heritage, there is a wide range of opportunities for the preparation of intercultural competence of students.

MATERIALS AND METHODS

There are factors of preparation of students for intercultural competencies are of particular importance, firstly, to increase the effectiveness of the teaching process, secondly, to ensure the preparation of students for intercultural competence in the educational process and the acquisition of skills of cooperation, innovative approach to the formation and development of scientific worldview. The effective use of such factors requires the teacher to be creative, self-seeking, responsible, active, communicative and cognitive. In each lesson, the



teacher must be able to clearly set goals, correctly identify the tasks to be performed, see future plans, and enrich thoughts and ideas about the future:

- Be able to form and develop skills and competencies such as scientific content, consistency, accuracy and reliability of facts, objectivity and educational nature of information, increase students' interest, expand knowledge, be highly moral;
- Students should be able to communicate in a foreign language through the acquisition of foreign languages, to communicate in a foreign language and to acquire information about intercultural communicative competence;
- Communication with students in the classroom and should involve not only the verbal exchange of information or the satisfaction of their communicative and cognitive needs, but also the exchange of emotions and cultures.

Nowadays, teaching a foreign language as a means of communication is considered important, and the need to teach this process in cultural components is approached separately. Any language serves to promote the specific characteristics of a particular culture. If the students are not aware of the culture of the country where the language is studied and the principles and laws of intercultural communication, a high level of communicative competence in learning a foreign language is not a guarantee of intercultural communication. Therefore, foreign language teaching and intercultural communication skills should become an integral process of education. The problem of intercultural competence formation is especially relevant for graduate students, as higher education practice shows that students have a high level of communicative competence in learning a foreign language, but in most cases do not have sufficient intercultural knowledge and intercultural communication skills. In turn, it can lead to the formation of a biased attitude towards "other" linguocultural representatives, a lack of understanding of intercultural values and even intercultural conflict.

The problem of intercultural communication and intercultural competence has been the subject of research by many scholars. In particular, Russian scientists such as I.I.Khaleev, S.G.Ter-Minasov, G.M.Andreev, T.A.Dmitrenko, N.M.Gromov, N.D.Galskov, V.P.Furmanov, A. A.Leontev, I.A.Zimnyaya, I.L.Bim, R.P.Milrud, E.S.Polat, V.V.Safonova, P.V.Sysoev, V.V.Oshchepkova, A.A. Miroljubov, GV Elizarova, G.V. Grom; Western scientists Byram M., Fleming M., Spitzberg B., Samovar L., R. Porter who addressed this problem. In order to determine the theoretical foundations of intercultural competence, it is necessary to refer to the following terms and concepts: "culture", "language", "intercultural communication" in this research.

In modern humanities, the concept of "culture" is one of the fundamental concepts. The concept of culture is studied in the fields such as semiotics, sociology, history, anthropology, axiology, culturology, ethnology, philosophy and a number of other disciplines. Each of them defines one aspect or function of the concept of culture as the subject of its study, approaches it from the point of view of its own methods and techniques and consequently gives its own definition of the concept of culture.

Culture is often described as a means of uniting different people and also regarded by a particular nation as a source that has been accumulated over the centuries, i.e., all forms of attitude towards nature, from ideas to concepts to language semantics. The scholar Giddens writes that culture promotes the idea that values created by certain social groups are reflected in the norms that must be followed in life, as well as in the material wealth produced by human beings. Teaching students about world literature and history, customs and traditions in the formation of intercultural competence requires a teacher to be always knowledgeable and active. In the development of intercultural competence of students, it is expedient to meet their needs, increase their interest through independent work, various creative works (essays, abstracts, etc).

RESULTS AND DISCUSSIONS

Independent work is an integral part of pedagogical and student activities. In independent and creative work, the student works on himself, seeks creativity, expresses his worldview and spiritual level, along with the formation of his own views and opinions. Independent work requires more work on the textbook, analysis of the content of the sources, preparation of lectures, abstracts, abstracts, creative essays (also in foreign languages), written answers to cards, various tables, diagrams and schemes. All of this requires research from the student. Independent work is based on 4 different sources in the organization of seminars.

- a) Textbook materials;
- b) Spiritual heritage, folklore, religious sources, classical literature, etc .;
- c) Materials of mass media (magazines, newspapers, radio broadcasts, world programs);
- g) Life examples (family traditions, customs, rituals, spiritual values, etc.).

Extensive use of some types of independent work (essays, written answers to questions, filling in tables, diagrams, cards) in the form of mixed lessons, aimed at strengthening the essence of the subject and the nature of the subject in practice. It is useful to use games in a foreign language or literature class. For example, in literature classes you can organize



debates and debates, such as "Our guest of scholars", "Temurids", "Today - through the eyes of scholars". In the methodological lessons, "Spiritual heritage of the Orientalists" is very useful for the organization of students' self-reflection. The use of spiritual resources by teachers in the classroom, regardless of "how the lesson is organized" (workshops, discussions, workshops, test class, etc.), taking into account their impact on education, active, creative, strong, spiritual heritage. One of the most effective ways to build intercultural competence is to develop students' traditional forms of oral learning. In this case, it is possible to hold debates on various topics. In the process of preparation for such lessons, students will be able to use a wide range of scientific, popular, autobiographical works, press and media materials on spiritual life, art, folklore, pandnoma, religious sources and the life of orientalists. As a result, the problem will be answered and the ancestors will be able to get acquainted with the spiritual heritage. If such lessons are organized on the basis of training, skills and extensive knowledge, experience, independence, the use of the following factors that shape the intercultural competence of the student will achieve high results:

- Doing independent activity of the student during the lesson;
- To teach students to rely on the opinion of the community, to respect it, thereby fostering in them a culture of mutual respect, communication, communication and cognition;
- Students acquire the skills to defend their ideas, opinions, to communicate with others;
- The ability to accurately assess the views of this or that writer, the essence of the issues raised on the basis of folk pedagogy, life experience, the possibility of environmental demand;
- The level of students' knowledge of the spiritual life of Uzbeks and other peoples will increase, moral and spiritual qualities will be formed;
- Every student has a sense of self-reliance, self-control, focus on self-awareness, self-awareness. Such a successful result will be reflected in the test lessons, the final lessons.

The main criteria for the formation of intercultural competence of the student are: humanity, diligence, national pride, patriotism, love, faith, creativity, activism, initiative, self-control and self-assessment. This requirement is realized through the student's attitude to the duties of the homeland, parents, friends, community, the characteristics of activity, creativity, which is manifested in the educational process. The organization of self-knowledge, behavior, control of attitudes to the environment, the organization of self-assessment is effectively manifested through the written creative activity of the student. Effective forms of education It is necessary to use a wide range of tools and methods

of traditional and non-traditional types of lessons, including various types of creative writing of students in the educational process: essays, abstracts, abstracts, lectures.

CONCLUSION

In order to effectively use the written and creative work of students in the classroom, it is necessary to adhere to a number of pedagogical conditions.

- Clearly define the types, themes, nature and requirements for independent creative work;
- Organization of independent written work in a foreign language, literature or other subjects and preparation of short methodical recommendations for their implementation;
- The teacher has sufficient knowledge of the spiritual qualities, spiritual history, the content and nature of values, knows how to effectively use their educational potential;
- Independent work of both teacher and student with textbooks and additional resources;
- The teacher is armed with a complete pedagogical knowledge of traditional and non-traditional forms of education, their educational opportunities, the results of work;
- The teacher must be able to anticipate the impact of each lesson topic, form, methods and tools on the forms of culture of student behavior;
- Written creative work should be carried out on the basis of voluntariness, creativity, interest of students. The spiritual environment created during the course shapes students' creativity, freedom, activism, imagination and interest in knowledge. Our spiritual heritage in the course of the lesson: the views of scholars of the past, various stories about morality, various folk tales, the use of proverbs to give students a thorough knowledge of the treasures of our spirituality, to demonstrate the acquired knowledge filling, mood, imaginative perception, expression of feeling, responsiveness, sensitivity.

REFERENCES

1. *Mirziyoev Sh.M. Critical analysis, strict discipline and personal responsibility should be the daily rule of every leader's activity. -T. : "Uzbekistan". - 2017.- p.102*
2. *Vygotsky, L.S. Collected works: V6t.Vol6 / L.S.Vygotsky.- M. : Pedagogy, 1984.-p.400*
3. *Galskova, N.D., Gez, N.I. Theory of teaching foreign languages: Lingvodidaktika methodology: Textbooks for students. Lingua.untovifak.in.yaz. higher. ped. study. institutions / N. D. Galskova, N.I. Gez. - 2nd ed., Rev. - M. : Publishing center "Academy", 2005. - p.336*
4. *Bennett, M. J. Overcoming the Golden Rule: sympathyandempathy // Bennett M. J. (ed.) Basic concepts of interculturalcommunication.Selectedreadings. - Intercultural Press, Inc., 1998b. -P.191-214.*



5. *Muhamadjonovna, S. D. (2020). The key concepts of forming sociolinguistic competence of future English language specialists. Asian Journal of Multidimensional Research (AJMR), 9(5), 118-121.*
6. *Muhamadjonovna, S. D. (2020). The development of sociolinguistic competence of future English language teachers through computer technologies. European Journal of Research and Reflection in Educational Sciences, 8 (3) Part II, 147-150.*
7. *Sarimsakova, D., & Rashidova, S. (2017). DEVELOPING INTERCULTURAL COMPETENCES WITH CASE STUDIES. In WORLD SCIENCE: PROBLEMS AND INNOVATIONS (pp. 212-214).*
8. *Sarimsakova, D. (2019). Communicative competence as a result of EF teaching and learning ISJ Theoretical & Applied Science, 12 (80), 166-169 <https://dx.doi.org/10.15863>. In TAS (Vol. 80).*
9. *Sarimsakova, D. M. (2020). SOCIOLINGUISTIC COMPETENCE AND COMMON REFERENCE LEVELS OF THE CEFR. In МИРОВАЯ ЭКОНОМИКА. ПРОБЛЕМЫ, ПЕРСПЕКТИВЫ, ИННОВАЦИИ (pp. 4-6).*



VISUAL AIDS AND TECHNICAL AIDS IN TEACHING ENGINEERING GRAPHICS

Mambetov Rashid Mirzalievich*

**Department of General Professional and Economic Sciences,
Almalyk Branch of Tashkent State University, Uzbekistan*

Tanjariva Rano Akramovna**

***Department of General Professional and Economic Sciences,
Almalyk Branch of Tashkent State University, Uzbekistan*

ABSTRACT

In modern teaching, visual aids and teaching aids play an important role. This article is due to the development of artistic and creative abilities of students in the visual arts. the theoretical substantiation and development of ways to activate students in the process of teaching them special disciplines, experimental verification of the effectiveness of the proposed method of using visual aids, and involving students in the design of special equipment and visual aids are considered.

KEY WORDS: *engineering, engineering graphics, support technician, artistic and creative abilities*

DISCUSSION

In recent years, the organization of the educational process in the discipline "Engineering Graphics" has risen to a qualitatively new level - now instead of a pencil, ruler and paper, students in the classroom work with specialized software. This step was due to the requirements of the modern labor market for graduates.

Renovation, new computers and laboratory furniture, the friendly attitude of teachers and the relevance of the software used increase the interest of students in studying the discipline. Complex drawings and diagrams are created on computers, displayed on monitor screens, and can be easily modified and edited.

When using modern information technologies for teaching, a printer, plotter, scanner or other peripheral devices should be provided in the office. To conduct training, student desks for a computer (computer desks) with space for a printer, scanner and other peripheral devices must be installed.

The number of computers is determined based on the area of the classroom, provided that there is at least 6 square meters per computer.

The teacher's workplace is also equipped with a computer table, a chair and a personal computer connected by a local network with students' computers. The teacher's table and equipment stand should be located 1.5 - 2 m from the front wall to enable the use of the overhead projector. The overhead projector should be placed on a stand and at the teacher's desk at a distance of at least 1.8 m from the board.

The cabinet can also be equipped with projection, video and audio equipment:

- Overhead projector;
- epiprojector;
- Overhead projector;
- Other projectors;

- color TV with a diagonal screen size of at least 61 cm with a VCR, DVD-player.

A projection screen or part of the chalkboard (or one of the doors) must be white in order to display the projection screen. Although modern projectors do not require special screens.



Sanyo PLC-XU41 with a luminous flux of 1500 lumens, 298x71x214 mm, 2.7 kg XGA resolution (1024x768 pixels). In terms of the main lighting and weight and size parameters, this projector is similar to the well-proven PLC-XE20 model, but it also has additional functions: the ability to select the Blackboard mode for projection onto a green chalkboard with automatic color correction, which ensures perception while maintaining the original color palette;

Dimmer function to automatically adjust the luminous flux depending on the displayed video signal, providing the best contrast of the projected image; on-screen menus in Russian; Key lock and PIN code functions to protect the projector from unauthorized access.

All screen, sound and screen-sound aids should be kept away from the heating system.

Audio and video tapes, floppy disks and disks should be stored in metal safe-type cabinets.

Stationary and mobile technical teaching aids (TTA) should be used in the educational process. Mobile TTAs should be installed on portable and folding or mobile stands in accordance with the requirements for stands for technical training aids.

AutoCAD offers the most advanced drawing tools, as well as convenient 3D modeling tools. This program is a platform for building CAD systems of various levels of complexity.

3ds max is a popular 3D modeling and rendering software. It includes all the necessary tools for architectural modeling: a set of standard objects (windows, doors, stairs, fences) and a library of various architectural materials. The application allows you to quickly work and, experimenting with various elements of models and spaces, you can immediately see how they look. 3ds max interacts with solutions built on the AutoCAD platform.

MAYA was developed ideologically as a professionally oriented program. Innovations in dynamics calculation and technology in hair and fluid simulation have made Maya the premier special effects tool for film and video. A high level of integration with third-party tools, both visualization and modeling, allows the world's leading studios to embed Maya into their workflow, whether it be developing computer games or creating special effects for film and television.

AutoCAD is the world's most famous computer-aided design system.

The AutoCAD system, as well as software products based on it, significantly increase the speed of working with projects of various sizes, allow you to create and update design data more efficiently.

AutoCAD2007 is a completely new level of 3D model building capabilities compared to previous versions. At the initial design stage, a conceptual model of the object is created and edited using

AutoCAD tools. The resulting result is used to build the final three-dimensional model, which serves as the basis for the formation of all output documentation: specifications, flat drawings, presentation materials.

AutoCAD 2000 drawing automation suite is a powerful drawing tool. It provides fast and accurate generation of the drawing you want to follow your instructions. It gives you the tools to easily correct mistakes made in the course of your drawing and even make major adjustments without having to re-create the entire drawing. It generates clean, accurate final designs.

AutoCAD 2000 works for you. It does not put anything "from itself" into your drawing. The completed drawing, produced using AutoCAD 2000, looks virtually identical to the drawing as if the drawing had been produced with the utmost care by hand. ("Virtually" because AutoCAD 2000, when used with the right hardware, can dramatically improve accuracy.) Your drawing is configured exactly according to your instructions, and each element is placed exactly where you want to place it.

AutoCAD 2000 is a drawing automation (DRA) application for your microcomputer. DMA applications are a very powerful tool. The speed and ease with which the preparation and modification of a drawing using a computer system can be performed, provide significant time savings compared to "hand" drawing. AutoCAD 2000 provides the microcomputer user with capabilities previously available only on large and expensive computing systems.

There are virtually no restrictions on those types of drawing work that can be performed using the AutoCAD 2000 system. If a drawing can be created manually, then it can be generated by a computer.

Here are some of the system's features:

- Architectural drawings of all kinds;
- Interior design and room planning;
- Technological schemes and organizational charts;
- Curves of any kind;
- Drawings for electronic, chemical, construction and engineering applications;
- Graphs and other representations of mathematical and other scientific functions;
- execution of art drawings.

AutoCAD DesignCenter (ADC) allows you to view or copy data from any drawing. Need to flip through the contents of a drawing? Very simple - blocks, layer definitions, layouts and xrefs are taken from many sources and inserted into the current drawing. If the block or target drawing has assigned units, then the block is automatically scaled according to the specified data. The built-in search



function allows you to search for drawings using information about their contents.

LITERATURE

1. *А.А. Программно-методический комплекс №6. Школьная система автоматизированного проектирования. Пособие для учителя // М.: КУДИЦ, 1995.*
2. *Иванов Н. Компьютерное образование // Компьютер Пресс, 1996.*
3. *Христочевский С. Мультимедиа в образовании // Компьютер Пресс, 1996.*
4. *Umirzakov R. R., Usenova S. USE OF ELECTRONIC TEXTBOOKS (EXAMPLES TOPIC: DETERMINING THE INTERSECTION OF SURFACES WITH THE SITUATION IN A PARTICULAR PLANE) //Теория и практика современной науки. – 2019. – №. 2. – С. 77-80.*



THE MAIN FEATURES OF PEDAGOGY IN THE FIELD OF ART

Akhmedov Tulkin Baltaboevich

National institute of fine art and design named after Kamoliddin Behzod , Uzbekistan

Umirzakov Rakhmatilla Rakhmonberdievich

National institute of fine art and design named after Kamoliddin Behzod , Uzbekistan

ABSTRACT

This article discusses the main features of pedagogy in the field of art. The importance and main features of pedagogy in human life are analyzed.

KEY WORDS: *pedagogy, method, methodology, function, motive, art, person*

DISCUSSION

At each stage of the historical development of society, pedagogy as a science reflected the state of education, training and upbringing of the younger generation. The development of pedagogy as a science took place in the mainstream of philosophy (knowledge about man and society). Only in the 16-17 centuries, pedagogy is becoming an independent science. Within the framework of philosophy, they mainly considered the view of the world and the place of man in it, the relationship between man and society.

Pedagogy as a private science focused on the problems:

- Person;
- Personality and society;
- Upbringing, education, training;
- Ideals of education;
- Ideal of personality in society.

Pedagogy is becoming the science of education, the process of enlightenment and self-education of the individual. Science is a sphere of human activity, the result of which is new knowledge. The object of pedagogy is education in a broad sense. The subject of pedagogy is a system of relations arising in the course of education; upbringing as a consciously organized process taking place in the family, society, in certain natural, social, economic, spiritual and moral conditions. Three fundamental concepts of pedagogy: upbringing, training and education. The question of their

relationship is controversial, but historically upbringing includes training and education. Personality formation is a process of development, becoming in the specific conditions of society. Personality is the social essence of a person, acquired in the course of communication and activity and is expressed in achieving the required level of activity and self-awareness. Personality formation is the process of personality formation as a result of the objective influence of heredity, environment, purposeful upbringing and the individual's own activity. Development is an objective process of internal sequential quantitative and qualitative changes in the physical, mental and spiritual forces of a person, ensuring the realization of his life potential, essence and purpose. The driving forces of development: internal contradictions between the capabilities of the individual and his needs, external contradictions between the capabilities of the individual and the requirements of society. Development factors: internal (hereditary genotype, psychophysiological properties), external (upbringing, environment).

Upbringing is the transfer of historical and cultural experience from generation to generation. Educational relationships are a kind of relationship between people, aimed at human development through upbringing, education, training. Self-education is the process of assimilation of the experience of previous generations by a person through internal mental factors that ensure



development. Education is the culture of the individual, the process of familiarizing a person with the values of science, art, religion, morality, law, and economics. Education is the foundation of personal development. Gessen Sergei Iosifovich (1887-1950): "Genuine education does not consist in the transmission of the cultural content that is a feature of the educating generation, but only in communicating to it that movement, continuing which it could develop its own new cultural content."

The formation of a creative personality according to Hesse as the main goal of education. Education:

- Formation of the way of thinking, human actions in society.
- The process of assimilating knowledge, abilities, skills.

Self-education is a system of internal self-organization to assimilate the experience of generations, aimed at their own development. Training:

- A two-way process of learning and teaching
- The process of transferring and assimilating knowledge, abilities, skills, methods of cognitive activity. Teaching - the child learns the world. Teaching - guiding the pedagogical process of the child's cognitive and educational activities. Thus, pedagogical activity includes the management of the student's activities and the management of the process of interaction with the student.

Self-education is the process of direct acquisition by a person of the experience of generations through his own aspirations and by himself chosen means. The content of education is a system of knowledge, skills and abilities, the mastering of which lays the foundations for the development and formation of a person's personality. Education is the dissemination of scientific knowledge about man and the world as a whole (in the 20th century, education is expressed in the form of the dissemination of knowledge in the field of economics, law and law, art, pedagogy and psychology). Education system - there is general and special education. General - primary and secondary (knowledge, skills and abilities required by everyone). Special - secondary special and higher (knowledge, abilities and skills necessary for a particular profession). A pedagogical problem is an objectively arising question in pedagogical theory and practice regarding the processes of teaching and upbringing. The pedagogical task is the result of the teacher's awareness of the goal of teaching or upbringing, as well as the conditions and methods of its implementation in practice (translation from "ignorance" to "knowledge", from "misunderstanding" to "understanding", etc.). Pedagogical activity is defined as the solution of

pedagogical problems. Because pedagogical activity is joint (the profession is "person" - "person"), then it is built according to the laws of interaction between teacher and student. The pedagogical process is a way of organizing educational relations, which consists in the targeted selection and use of external factors in the development of participants. The pedagogical process is the process of teaching and educating a person as a special function of society, implemented in the context of a specific pedagogical system. The study of the pedagogical process is the basis of pedagogy. in accordance with the pedagogical process, methods, techniques, methods of pedagogical activity are created.

The structure of the pedagogical process: Purpose (final result) Principles (main directions of achieving the goal) Content (actual teaching material) Methods (actions of the teacher and the student for the front Means (ways of "working" with the content) Forms (logical completion of the process)

SOURCES USED

1. Ursul A.D. *Formation of the information society and the model of advanced education* // NTI. Ser. 1. - 1997. - № 2
2. Okolelov O.P. // *Pedagogy*. - 2001. - № 6 3. Elkonin B.D., Frumkin I.D. // *Questions of psychology*. - 1993. - №1.
3. Умирзаков Р. Р. ПЕДАГОГИКА-ПРЕДМЕТ, ЗАДАЧИ, ФУНКЦИИ // *Мировая наука*. - 2018. - №. 6. - С. 348-351.
4. Дадабаева Д. Э., Умирзаков Р. Р. МЕТОДИЧЕСКИЕ РЕКОМЕНДАЦИИ ПО ЧТЕНИЮ ЧЕРТЕЖЕЙ ПУТЁМ СОЗДАНИЯ МОДЕЛЕЙ // *Теория и практика современной науки*. - 2019. - №. 2. - С. 170-176.



SIMULATION OF CODING METHODS BASED ON TWO-DIMENSIONAL PREDICTION AND TWO-WAY ERROR SIGNAL LIMITATION

R.Usmanov

Senior Lecturer, Namangan Engineering Construction Institute

E.D.Imomnazarov

Senior Lecturer, Namangan Engineering Construction Institute

ANNOTATION

This article discusses the development of the above method by modeling algorithms and software for constructing long-range video information systems with statistical filtering of impulse noise. With the help of which, it is possible to improve the quality of the received images with impulse noise of various duration and intensity.

KEY WORDS: *video information systems, analog prediction, impulse interference, signal-to-impulse noise ratio (STIN), encoder analyzer.*

ИМИТАЦИОННОЕ МОДЕЛИРОВАНИЕ МЕТОДОВ КОДИРОВАНИЯ НА ОСНОВЕ ДВУМЕРНОГО ПРЕДСКАЗАНИЯ И ДВУХСТОРОННЕГО ОГРАНИЧЕНИЯ СИГНАЛА ОШИБКИ

Р.Усманов. Старший преподаватель
«Информатика и информационный технология»
Наманганского инженерно-строительного института

Э.Д.Имамназаров. Старший преподаватель
«Информатика и информационный технология»
Наманганского инженерно-строительного института.

Аннотация: В данной статье рассматривается разработка выше указанного метода путем моделирования алгоритмов и программных средств построения дальних видеоинформационных систем со статистической фильтрацией импульсных помех. С помощью которых, обеспечивается повышения качества принимаемых изображений с импульсными помехами различной длительности и интенсивности.

Ключевые слова: видеоинформационные системы, аналоговое предсказание, импульсная помеха, отношение сигнал – импульсная помеха (ОСИП), кодер анализатор.



Научно – технический прогресс наряду с комплексными проблемами ставит и проблему увеличения достоверности обмена видеoinформацией. Особенно сложные проблемы возникают в связи расширением обмена видеoinформацией, что вызвано не только развитием систем для вещания, но и ещё в большей степени сложных видеoinформационных систем различного назначения. Это актуально также для качественного экологического мониторинга при одновременном увеличении расстояния, на которые приходится передавать или принимать изображения.

В дальних видеoinформационных системах с низким отношением сигнал – импульсная помеха (ОСИП) из-за порога частотного дискриминатора принятые изображения поражаются импульсными помехами. Теоретические и экспериментальные данные, показывают, что аналоговое кодирование-декодирование на основе линейного предсказания и ограничения с обратной улучшает помехоустойчивость видеoinформационных систем.

Для поиска максимального выигрыша в (ОСИП) необходимо рассматривать множество вариантов, в которых варьируется различные параметры (уровень ограничения, весовые коэффициенты предсказателей, остаточный сигнал, количество элементов участвующих в предсказании и т.д.). Схемная реализация с целью проведения опыта со всеми вариантами достаточно сложна, требует больших затрат на конструирование, а иногда и просто невозможна (когда для предсказания используются элементы из предыдущего поля или кадра) в реальном времени. Выход здесь только в обращении к современным ЭВМ.

Рассмотрим имитационное моделирование видеoinформационной системы с линейным предсказанием, ограничением и анализатором как эффективный статистический фильтр импульсных помех. В сущности, алгоритм имитирующий необходимые действия такой видеoinформационной системы, представляет собой рекурсивную процедуру, на рис.1 приведена блок-схема алгоритма. Исходное изображение задано на квадратной решетке 512x512 элементов изображения по 8 бит каждый, т.е. 256 возможных значений, что вполне соответствует телевизионному стандарту [1,2]. Для имитации подачи сигнала изображения сканировались (слева направо, сверху вниз) нечетные строки (1-е поле), четные (2-е поле). Аналогично восстановление (после обработки) изображения получалось после перемежения двух полей. Для зашумления использовался специальный массив noise, записанный как изображение в ЭВМ и имеющий характеристику распределения вероятности, близкую к импульсным помехам. Например, если имеется <<белый>> шум, обозначенный как $U(I,j)$, ($I,j=0,1,2,...,512$) то для получения <<треугольного>> достаточно проделать операции:

$$\eta(i,j) = U(i,j) - 1/3\{U(i-1,j) + U(i,j-1) + U(i-1,j-1)\}. \quad (1)$$

Соответствующее ослабление шума подбирается по коэффициенту сжатия N.

В описываемых моделях рис.2 для предсказания использовались, в основном, апертюра из шести предыдущих элементов (трех из данной строки и трех из предыдущей) рис.2а.

Для настройки и идентификации модели вначале использовались тестовые изображения (шахматное поле, сетка, полосы и т.п.) с известными результатами восстановления, а также детерминированный шум (регулярная импульсная помеха, сбой).

Для проверки локализации помехи задавалась различная ориентация трека ошибки (соответствующий подбор весовых коэффициентов, вариация <<утечки>>). Реальные изображения пропускались через алгоритмы при различных условиях. Весовые коэффициенты предсказателей получены с помощью ковариационного анализа некоторого ансамбля типовых изображений с применением рассредоточения значения весов при многоэлементном предсказании. Такое имитационное моделирование, позволило исследовать и выявить многие эффективные и перспективные стороны видеoinформационной системы с аналоговым кодером и анализатором на основе линейного предсказания и ограничения обратной связью как статистический фильтр импульсных помех.



Блок схема алгоритма функционирования базовой модели видеoinформационной системы

с линейным предсказанием и ограничением



Рис. 1



Расположение элементов изображения используемых для предсказания

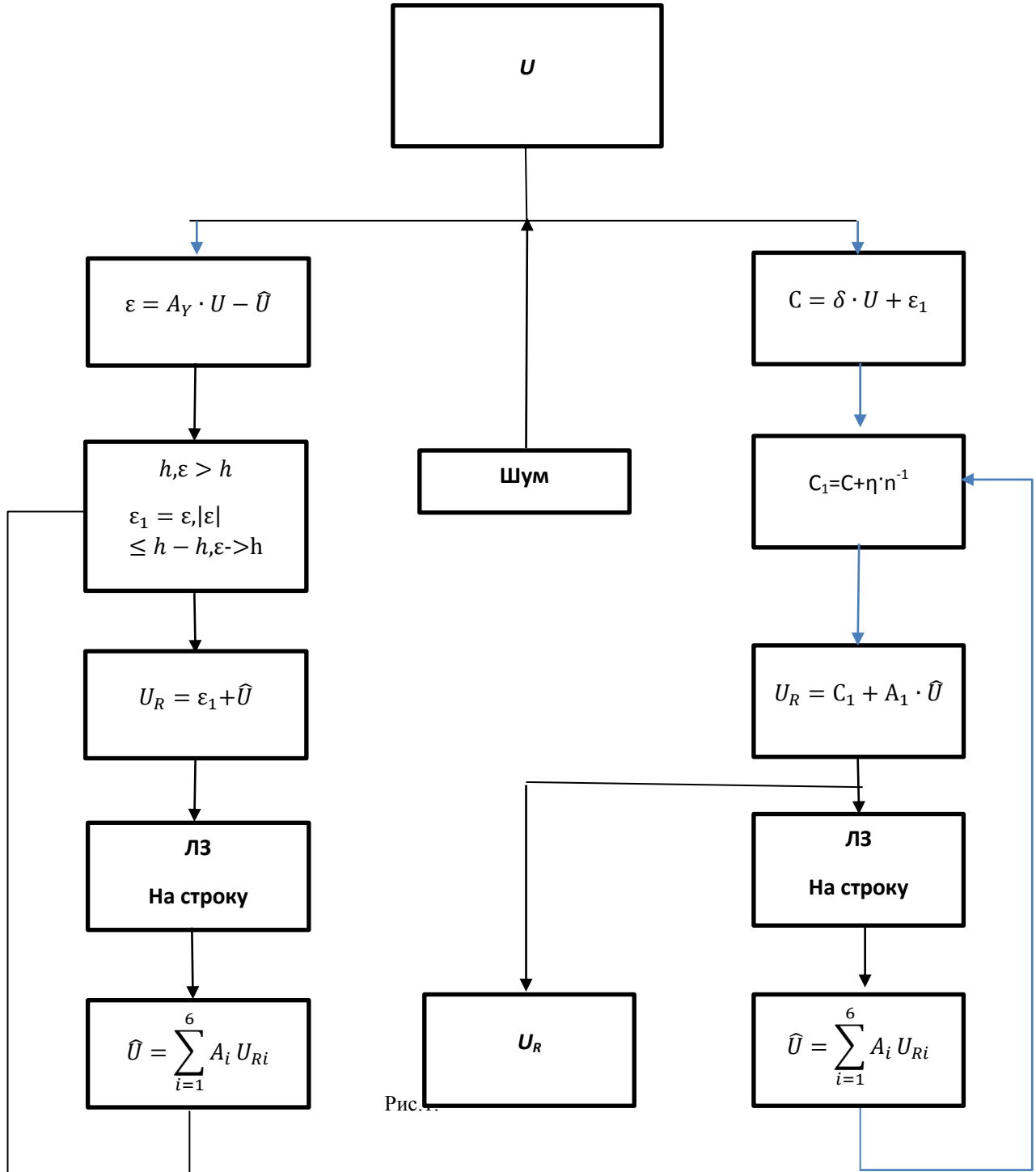
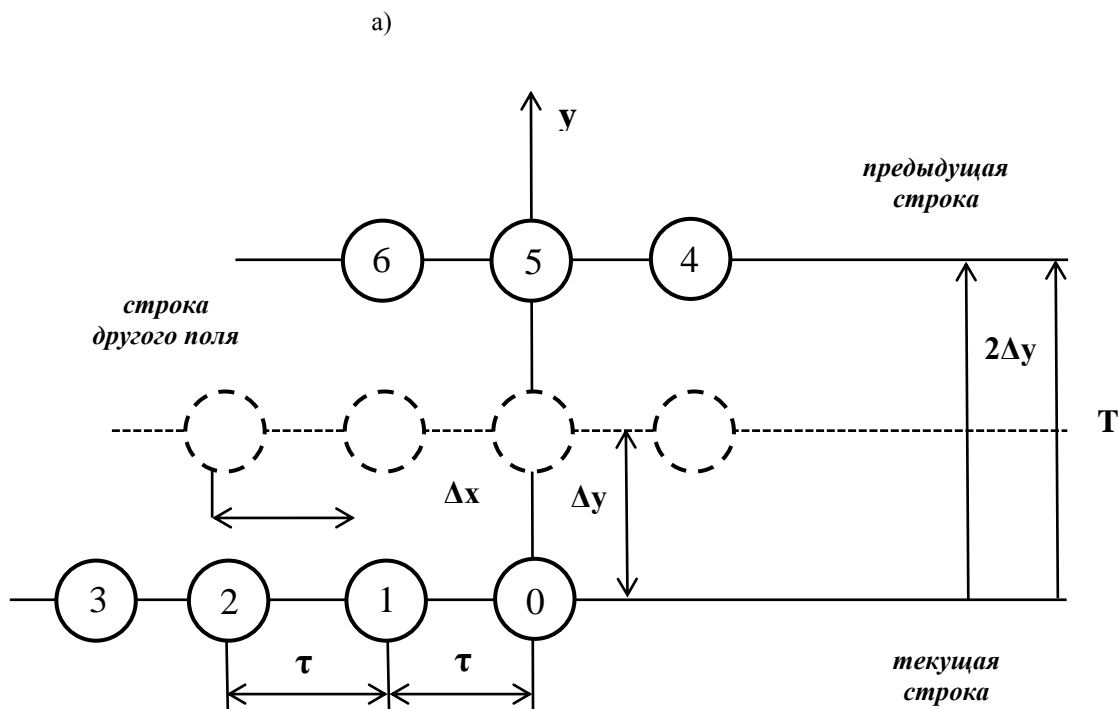

Схемная реализация предсказания

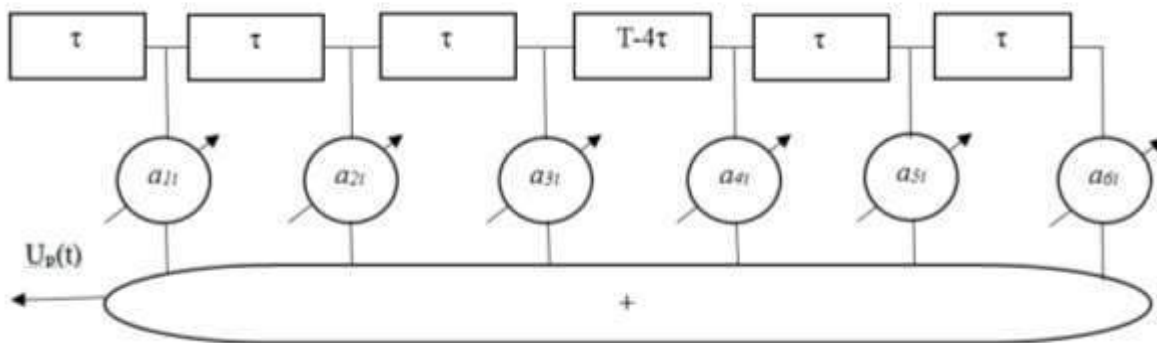

б)

Рис.2

Точность предсказания зависит от соответствия алгоритма предсказания, сложности сюжет и локальной окрестности. Рассматривались параметры аналоговых кодеров, которые устанавливались фиксированными для всего ансамбля изображений. Весовые коэффициенты предсказателей определялись для трех типов сюжета и усреднялись, что вело к увеличению дисперсии разностного сигнала, а значит и к снижению эффективности фильтрации импульсных помех [3,4.5,6]. Поэтому проблема дальнейшего повышения эффективности видеoinформационной системы с аналоговым кодером и анализатором как статистический фильтр импульсных помех чрезвычайно актуальна.

**Список использованной литературы.**

1. Атаханов Р.М.и др. провести НИР по выбору ТВ устройств в аналоговом и цифровом вариантах повышения помехоустойчивости передачи сигналов цветного телевидения на основе адаптивного линейного предсказания и ограничения, а также испытать эти устройства на действующих каналах ТВ. Гос.рег. №01826031789, Ташкент, ИК с ВЦ АН УзССР, с.65, 1983.
2. Маматходжаев В.Н. Разработка и цифровое моделирование блоков предсказания и корректирования на основе линейного предсказания и ограничения. В кн. Всесоюзный симпозиум "Сокращения избыточности в цифровых телесистемах," с.73., Тбилиси, 1983.
3. Маматходжаев В.Н. Разработка и цифровое моделирование управляемой телевизион системы с линейным предсказанием и ограничением. Дисс. к.т.н., с. 148, 1986.
4. Махмудов Э.Б Исследование повышения эффективности использования пропускной способности канала связи посредством линейного предсказания и ограничения сигнала цветного телевидения. Дисс. к.т.н., с. 210. М., 1981.
5. Атаханов Р.М. Комплексное исследование методов повышения помехоустойчивости и эффективности использования пропускной способности ТВ системы с предсказанием и корректированием. Техника кино и телевидения, №7, с.21-23. 1985.
6. А.С. 1387860 (СССР). Устройство для передачи телевизионного сигнала. (Атаханов Р.М., Курбанов Т., Маматходжаев В.Н., Меликов А.Б.) 1986,д.с.п.
7. Р.Т.Усманов. Статистическая обработка видеoinформации." Инновация-2001" международная научная конференция. Тезисы докл. Ташкент.2001.
8. Имамназаров Эркин Дехканалевич. Как среда проектирования и моделирования при подготовке виртуальных лабораторий. "Теория и практика современной науки" №11(53) 2019.



THE IMPORTANCE OF EDUCATIONAL INNOVATION, MORAL AND SPIRITUAL EDUCATION IN THE DEVELOPMENT OF CIVIL SOCIETY

Kholmatov Shahobiddin

*Assistant of Professor, Candidate of Philosophical Sciences, Fergana Branch of Tashkent
University of Information Technologies Named After Muhammad Al Khwarizmi
Uzbekistan, Fergana*

ANNOTATION

This article provides a philosophical insight into the concepts of education, educational innovation, moral upbringing and spiritual upbringing. At the same time, the article examines the importance of educational innovations, as well as moral and spiritual education in the development of society, based on certain theories.

KEYWORDS: *education, educational innovation, upbringing, morality, spirituality, moral upbringing, spiritual upbringing.*

INTRODUCTION

It turns out that the society of personality, a person sees work, relying on ideas that represent a certain belief that develops and improves in his daily activities. Usually this is expressed in believe specific social teachings. In this sense, it is not possible to find a person society that is not interrelated with social teaching. After all, people live their lives, relying on a certain ideology, formed on the basis of spiritual experience, worldview, decided for centuries.

THE MAIN PART

When it comes to human nature, of course, it is emphasized that it is a thinking, intelligent and at the same time a social being. Indeed, let us not take into account what aspects of it, the shortcomings of its qualities(except by biology), they will eventually depend on the mind, thinking, community of man. In turn, the sociability and mind, thinking of a person are inextricably interrelated and complement each other.

In a situation where the process of development of human knowledge in a society is in harmony with innovative activities, it is classified as putting on some problems and switching to solving them, and then finding a solution to the new problems that have arisen. President of the Republic of Uzbekistan Shavkat Mirziyoyev: "Today we are

moving on the path of innovative development aimed at radical renewal of all spheres of life of the state and society... Innovation means the future. It is not surprising that when we begin to steam the restoration of our great future, we must start it on the basis of innovative ideas, innovative concessions"[1].

The period of independence is associated with the restoration and development of the spirituality of national independence, the development of the national language and culture, national emotions, the cultivation and strengthening of patriotism. The development of independent Uzbekistan is connected with the spiritual perfection of members of society, each individual and especially young people, the deep integration of ideas of independence into the minds of people, everyday life. National consciousness and national self-consciousness as a result of independent development are the main foundations of spiritual perfection[2].

In every family, in every neighborhood, first of all, ensuring the health of our young people, giving them a good education, at the same time, reaching adulthood as a worthy person with high moral and ethical qualities has become an important issue from time immemorial. In the years of Independence, these tasks have risen to the level of public policy in Uzbekistan, which has made it possible to achieve high achievements in all spheres.



The analysis of facts, which affects the stability of the activities carried out in the Republic of Uzbekistan on the state policy on youth, requires to clarify the directions of the state policy on youth carried out in our country. These include the following:

1. "Harmonious generation" direction;
2. "Citizen of the Republic of Uzbekistan" direction;
3. "Youth and social protection" direction;
4. "Young family" direction;
5. "Youth professionalism" direction;
6. "In space of youth information" direction[3].

Currently, attention is paid to the application of interactive methods, innovative technologies, pedagogical and information technologies in the educational process. Therefore, the role of modern teaching methods in the training of qualified professionals at the faculties of higher educational institutions is great. At the same time, special attention should also be paid to the formation of moral and spiritual education in students in the process of teaching. The process of such pedagogical cooperation has its own characteristics, which include not to be indifferent to the student during the lesson.

Awakening thought in the student in the educational process requires great effort and skill from the teacher. Correct thinking means creativity. Therefore, the process of teaching in pedagogy is two-sided: the sum of the educational and teaching activities of the teacher performed by the pupil. Without denying this rule, the content of modern education dictates the harmony of universal and national experiences.

Education is the process of acquiring knowledge from a pedagogical point of view, the formation of qualifications and skills, the main means of preparing a person for life and labor.

From the sociological point of view of education, it is explained as follows: education as a modern form of teaching students in special buildings, with an increase in the level of general literacy, with the spread of printed items, was formed fold. Knowledge can now be stored, produced and used in many places and by many at the same time[4]. Education is characterized by bilateral communication (acquisition and training), comprehensive development of the individual and other characteristics. Education is a process of self-awareness, guided by a pedagogue.

The genesis of socio-cultural technologies in the scientific management of society is the development of science, the rise of human thinking and scientific knowledge. If we look at history, the activities of the owners of high ideas, great personalities are skillfully organized, deeply educated, not only with their morals and manners, but

also with a high sense of meaning. Morality is not the same as the others, it is also the saying to respect oneself. In particular, according to our national traditions, the perfection of man can be seen first of all in his moral maturity, in his efforts to deeply study the heritage of ancestors, enrich it, show great respect to them.

It is known that morality, moral upbringing is an ancient concept that is considered one of the main factors shaping national culture. Each nation has its own moral criteria, moral norms, tested by centuries. Morality plays a classical role in national spirituality. At the same time, nationalism and universality in morality form a single whole, united among themselves.

It is known from the views of the wise people of our country that attitude to life, morality, justice and spiritual research are built on the philosophy of perfection in society. According to this philosophy, happiness is the only creature that must strive for happiness and goodness and live on the basis of these principles. Because it has the ability to recognize, understand the existence that is different from other creatures, to stand higher than them. The rich spirituality and enlightenment, formed in the East, laid the foundation for development, which caused a sharp turn in the history of mankind in different periods, in different regions.

In order to further accelerate educational work in our country, on December 31, 2019, the Cabinet of Ministers of the Republic of Uzbekistan adopted a resolution "On approval of the concept of continuous spiritual education and measures for its implementation". One of the priorities of the implementation of the "concept of continuous spiritual education" is to increase the knowledge of the population on the upbringing of children, their pedagogical culture, regular acquaintance of citizens with effective methods of continuous spiritual education and forms of implementation. The purpose of the concept is to bring an adult of a high – quality, harmonious generation on the basis of the gradual formation of the necessary social skills and qualities for independent life in the younger generation corresponding to the age.

The concept covers four stages:

- the first stage: in families (the period of conception, the period from the birth of a child to the age of 3 years);
- second stage: pre-school education (3-6 (7) years of age);
- the third stage: general secondary education(7(6)-10 years of primary school, 11-17 (18) years of age);
- the fourth stage: young people who are engaged in production and are not employed, as well as in the system of secondary vocational and higher educational institution.



It should be noted that we can separately admit that young people who do not have enough knowledge, skills, life experience, who are not indifferent to their history, the identity of their ancestors, are naive, unsuspecting today fall into the trap of destructive ideas. At present, as a result of such actions in some parts of the world, one cannot ignore the great spiritual losses, the disruption of national consciousness, as well as religious values and lifestyle.

However, the ideological threat is becoming more and more new because of this, the independent Uzbekistan is now actively working on the formation of national idea and ideology, which is a unifying flag of the nation, society and state, as well as integration into the consciousness of our people. Today, when we observe the radical changes that are happening in our state, today our cities and villages are becoming more and more beautiful day by day. We can also observe a number of changes in the sphere of culture, art, education, science in the regions and remote areas. We can feel that the main goal of the ongoing changes is the high level of confidence and attention of our people to the future. After all, it is permissible to say that the formation and development of the national idea is a demand of modern.

From the first days of Uzbekistan's independence into the lake, a new historical period began, which brought about radical changes in the social, economic and political spheres, as well as in the spiritual, cultural, educational and ideological spheres on the way to building a legally democratic society. At the same time, based on the centuries-old traditions of our people, the humanitarian essence of Islam, our national cadres, the task of creatively using the advanced experience of developed countries, relying on the principles of development chosen by us, restoring the foundations of a free and prosperous and prosperous life, building a legal democratic state, a free civil society was set after all, it is a power - man who drives, implements and develops democracy: democracy does not only become a people's power, it is also the responsibility of every person, every community and the whole people before their country's future, their own destiny.

Recognizing that a democratic society is, first of all, a political system based on the principles of people's power, which guarantees freedom and equal rights to its citizens, in our opinion, is of concerted importance. Democracy is not only pure theoretical or political processes, but at the same time the way of life of the people. It is also cultural traditions, customs and its spiritual features. Ultimately, democracy is in the process of continuous development and improvement as a unit of form and content. From this it is possible to conclude that every state, society, nation or a certain historical

generation, even in the conditions of any social relations, create democratic processes in their own way, in their own unique, acceptable form. Against this background, they make their contribution to the improvement of democracy. When we say democracy in a general way, everyone's interests are understood to respect the authority of the majority and the will of the minority. It remains to be seen that democracy is both the people's view of their land and independence, and the protection of the interests and judgments of each individual from arbitrary restrictions and in this way from actions, and the form of self - government of citizens.

Therefore, it is necessary to educate young people on a healthy outlook, the priority of trust and national values, the immune system against various threats. Ideological protection is carried out through the system of education and propaganda. Social structures that serve to integrate healthy ideology into the minds and hearts of the people, family, school, neighborhood, state and public organizations also have their place in this process.

Conclusion.

As a conclusion, the educational process is important in the formation of moral and spiritual upbringing in young people. Because, if education is separated from education, that is, if we are limited only by the provision of knowledge to young people, they can acquire such knowledge, but they will remain untouched by such values as patriotism, nationalism, responsibility before the parents, the neighborhood. We must never forget that the sense of patriotism, which requires great responsibility from young people, is the most important concept for the state and society.

REFERENCES

1. 2017 йил 22 декабрь. Ўзбекистон Республикаси Президенти Шавкат Мирзиёевнинг Олий Мажлисга Мурожаатномаси. Тошкент. "Ўзбекистон", 2018. 20-бет
2. М.Абдуллаев ва бошқ. Мустақиллик: изоҳли илмий-оммабоп лугат. Тошкент, 2000. 114-б
3. Ўзбекистон Республикасида ёшлар сиёсатининг муаммолари ва ечимлари. Лекция № 16. Тошкент, 2014. 10-12-б.
4. Э.Гидденс. Социология. Ўқув қўлланма (Н.Маматов ва Ж.Бегматов таржимаси). Тошкент, 2002, 462-б.
5. Ш.О.Мамадалиев, М.Т.Тожибоев, Д.А.Юсубов ва бошқ. Ўзбекистонда демократик фуқаролик жамияти қуриш асослари. Маърузалар курси. Тошкент, 2008.
6. Т.Дўстжонов, М.Мирҳамидов, С.Ҳасанов. Ўзбекистонда фуқаролик жамиятини шакллантиришнинг долзарб муаммолари. Ўқув қўлланма. Тошкент, 2006.
7. Факторы развития гражданского общества и механизмы его взаимодействия с



-
- государством / под ред. Л.И.Якобсона. – М. :
Вершина, 2008.
8. Фуқаролик жамияти ва миллий гоя. Тошкент,
2005.
 9. М.Шарифходжаев. *Формирование основ
гражданского общества в Узбекистане /
Отв. ред. А.Х. Саидов. Ташкент, 2002.*
 10. М.Шарифхўжаев. *Ўзбекистонда очик
фуқаролик жамиятининг шаклланиши. –Т.:
“Шарқ”, 2003.*
 11. Х.Одилқориев. *Конституция ва фуқаролик
жамияти. – Т.: “Шарқ”, 2002.*
 12. Karimov U. et al. *USING NEW INFORMATION
TECHNOLOGIES IN DISTANCE LEARNING
SYSTEM //НОВАЯ ПРОМЫШЛЕННАЯ
РЕВОЛЮЦИЯ В ЗЕРКАЛЕ СОВРЕМЕННОЙ
НАУКИ. – 2018. – С. 9-11.*
 13. Butaboev M. T., Karimov U. U. *«ЗЕЛЁНАЯ
ЭКОНОМИКА». МИРОВОЙ ОПЫТ И
ОСОБЕННОСТИ РАЗВИТИЯ В
УЗБЕКИСТАНЕ //Theoretical & Applied
Science. – 2020. – №. 2. – С. 704-710.*



THE ROLE OF THE ISLAMIC TEACHINGS OF MOTURIDIA

Qambarov Abdumutal Akhadjonovich

Associate Professor of the Department "Philosophy", Candidate of Philosophical Sciences,

Karimov Ulmasbek Umaralievich

*Teacher of the Department "Civil society", Fergana State University,
City of Fergana, Uzbekistan*

ANNOTATION

In the article briefly highlights the religion of Islam and its essence. The article also scientifically investigated the creation and role of the Islamic teachings and the reasons for the spread of Islam to Movaraunnahr. Opinions and viewpoint of specialists in this regard are scientifically justified.

KEYWORDS: *religion, Islamic religion, word, belief, religious teaching, mysticism, sect.*

INTRODUCTION

It is known that the teachings of religion and religion were studied by the theologians (scribes). Religion is a socio-historical phenomenon, one of the forms of social consciousness that is at a certain stage of the process of the development of personality society. Although the essence of religion is explained in different ways, on its basis lies the feeling of trust, belief is recognized by almost all members of society.

Man is interested in the scientist who surrounds himself as he lives in this world. He thinks about what he consists of. The only teaching that regulates such thoughts, forms the basis of his life and gives rise to happiness is the religion of Islam. And to realize the essence of such a great doctrine serves as a torch that illuminates the ways of a person's life.

THE MAIN PART

Famous cities such as Bukhara, Samarkand, Shosh (Tashkent), Fergana, Kesh, Nasaf, Termez in the state of Somonids, which took the stage of history as an independent state in the X century, were considered centers of science and education. The conditions created for the people of peace, political stability and science established in the time of Ismail Somoni created the basis for the development of religious and secular knowledge. Even Baghdad, which was considered the most important scientific

and religious center of that period, was left behind by its scientific potential and achieved results.

According to academician Muzaffar Khayrullaev, Samarkand's location in the Great Silk Road contributed to the development of secular sciences, as well as religious sciences [1, 31]. It is known that in the Muslim East, all mature scholars studied fiqh, hadiths, tafsir and other Islamic sciences in major cities such as Baghdad, Damascus, Kufa, which were Islamic centers at that time. Also, theology, that is, the acquisition of knowledge on Islamic philosophy, was carried out in such large cities of Central Asia as Bukhara, Samarkand. For this reason, in this country, scientists of the great mysticism have reached. One of such scholars is Abu Mansur Moturidi, who has added his great share in the development of world science and Islamic religion.

Abu Mansur Moturidi is the founder, Imam of the great word and fiqh scholar of the teaching formed in sunni belief and teaches his first knowledge at the "Iyodi" madrasah in Samarkand. Moturidi Abu Bakr Ahmad Juzjani, Abu Nasr Ahmad Iyodi, a great scholar of the imam's sect Nasr ibn Yahya Balkhi, Muhammad ibn Fazl knows as his mentor.

Moturidi contributes greatly to the development of the School of Islamic theology in Movaraunnahr with its school traditions and scientific and religious works. His theological



sciences were fully formed and served for his perfection. He put them into a certain system and showed the hanafi instruction through his own views that it is associated with the customs of the peoples of Central Asia. His teaching is known as one of the great ideological currents of Islamic religion.

Abu Mansur Moturidi has been in contact with the mukhaddis throughout his lifetime and has had discussions. He has a worthy share in the work of spreading the hanafi sect of Islam in Movarounnahr and flawlessly bringing it to subsequent generations. Therefore, the Swedish orientalist scientist called this period "Muslim renaissance" [2, 89].

Imam Moturidi was considered the most mature scholar in the field of Islamic sciences of his time and was recognized by scientists of the Muslim world and is now also mentioned in various religious works with great respect. In particular, those who glorified Mansur Moturidi with such names as "Imam al-huda" and "Imam al-mutakallimin", "Imam of the path of guidance and Imam of mutakallims".

His knowledge rose to high ranks in the word and called the apprentices of Imam Moturidi, known as the incomparable sheikh of his time, "Moturidis" in the people's language. Also Imam Moturidi has not drawn up a separate sect. Perhaps, the Imam has published the fatwa and instructions of my member Abu Hanifa about the aqeedah, spreading it around. Even the person himself, who was subjected to the hanafi sect in furuot. Although in the books the terms "Moturidi sect" or "Moturids" are encountered, it is not right to understand this as a separate sect. It is also necessary to understand that Abu Hanifa's method is the Hanafi who studied and practiced Imam Moturidi's teaching in the field of religion.

According to the famous Turkish scientist Toshkubrozoda: the chairmen of the science of the word in "Ahli-sunnah val jamoa" are two people, one of them is Hanafi and the other is Shafi'i. Hanafi is Abu Mansur al-Moturidi, and Shafi'i is Abul Hasan Ash'ari." Although both imams did not see each other, their moturidia and ashariya teachings were much closer to each other. As a result, this mutual closeness, the union between them and the reconciliation, arises. But Moturidi unlike Ashari, man repeatedly confesses his freedom in his activities [3, 16]. From this does not come to look that a person should do what he likes. Abu Mansur Moturidi knows that despite the fact that the fate of each person is determined by Allah, he (Man) is responsible for his actions [4, 164].

Al-Moturidi teaching teaches that it is necessary not only to lean on the mind as mutazilis, but also to use the mind with the addition of an adverb. Another great contribution he made to the faith was that at that time, many sects had started the Muslim people in different ways with their own

thoughts. Al Moturidi made a huge contribution to this and the establishment of a single system of belief in this country. He proved all the controversial topics of his faith to each of the parties on the basis of evidence. As a result of this, the multiplication of various small currents took place. In the fiqh of Imam Moturidi rahmatullah alayh, Imam Abu Hanifa followed him in the same way as in the sects of Rahmatullah alayh.

Al-Moturidi cultivated many apprentices, among which were such scholars as the famous scholars of the Islamic World: Abu-l-Hasan ar-Rustugfani, Ishaq ibn Muhammad as-Samarkandi and Abdu-l-Karim al-Pazdavi, Abu Ahmad al-Iyodi. Due to the fact that the apprentices continued the teaching of their masters, the flow of Moturidia arose within the Hanafi sects [5, 88].

It can be seen that in the first half of the X century the influence of the influx of the qarmatis in Central Asia. Their main strength was made up of peasants, artisans, badavis, who gradually turned to the traps of this group into their supporters, starting from the city merchants, officials, palace nobles. And this led to the fact that the diversity of the peoples who lived under the rule of the abbasids, consisting of Arabs, Persians, Turks, yakhudis, christians, arose at that time, a negative situation that today is called nationalism. In particular, the Arabs switched to their own race, the Persians to their own race, the Turkic peoples to their own race.

The great Sheikh Muhammad Sadiq Muhammad Yusuf, who was recognized by the Islamic world, said that during the time when Moturidi lived, there was a period of incitement (atheism, disbelief in religion, godlessness) [6, 21] and they wanted to cause Muslims harm in this way. Nevertheless, the Abbasids had a thorough struggle against the act of excesses. The caliphs called on scholars to write books against them in order to educate the dungeons, to conduct explanations and discussions between them, to give refusals. In such a difficult period in Samarkand, people's discontent against the qarmatians is raised due to the scientific activity and courage of the scholars of Imam Moturidi and apprentices Imam Abul Qasim al-Hakim as-Samarkandi chief ahlu sunnah. They tried to overcome ignorance with their science-enlightenment, deep and profound thinking. In this way, they did not spare their own capacity and strength to maintain pure Islamic faith. It is worth noting that they are based on the teachings of the Qur'an and Sunnah, as well as on the teachings of Muhammad (s.a.v) in the style of companions began to clarify the issues of the mind. The Hanafis, Shafi'is, Malikis and Hanbalis, who recognized the Islamic world as the Ahli sunnah val jamoa of the people of the fiqhiy sect, laid the foundations for the



word schools of moturidia and ash'ariya in the belief sect. In particular, Abu Mansur Moturidi was among the first to receive mercy in this holy struggle against the currents of belief that led muslims to violence[7, 22].

CONCLUSION

Movarounnahr-the peoples of Central Asia, along with the world-famous figures, scientists in various fields of philosophy, natural, exact sciences, literature, art, brought up scientists who gained a name in the Muslim world as al-Moturidi in the field of Islamic theory, religious sciences.

In conclusion, we can say that today the study of the teachings of Abu Mansur Moturidi is of great importance in the moral and spiritual education of the youth as well as in the prevention of religious ignorance, and we also appreciate and understand the services of the great scholar Imam Moturidi before Islam, faith, religion-faith, Homeland and all mankind.

REFERENCES

1. Мец А. Мусульманский ренесанс. –М.: 1973.
2. М.Хайруллаев. Мотуридий даврида Ўрта Осиё маданияти. Ал-Мотуридий ва унинг Шарқ халқлари маданиятидаги ўрни. Маърузалар тўплами. Тошкент, 2000.
3. Зухриддин Хусниддинов тахрири остида. Ислом энциклопедияси. Ўзбекистон миллий энциклопедияси. Давлат илмий нашриёти. 2004.
4. Ш.Зиёдов. Абу Мансур Мотуридий. Тошкент, "Ўзбекистон", 2012.
5. М.Хайруллаев. Маънавият юлдузлари: (Марказий Осиёлик машхур сиймолар, алломалар, адиблар). Тошкент, 2001.
6. Шайх Муҳаммад Содиқ Муҳаммад Юсуф. Тошкент, 2014.
7. А.Хасанов, Н.Комилов, У.Уватов, А.Азимов, Қ.Зоҳидов. Ислом тарихи. Тошкент ислом университети. Тошкент, 2008.
8. "Виждон эркинлиги ва диний ташилотлар тўғрисида"ги Ўзбекистон Республикасининг Қонуни(янги тахрири) // Ўзбекистоннинг янги қонунлари, № 19. Тошкент, "Адолат", 1998.
9. Н.Ф.Низомиддинов. Шарқий Осиё диний-фалсафий таълимотлари ва ислом. Тошкент, "Зарқалам", 2006.
10. И.Н.Яблоков. Религиоведение: Учебное пособие и учебный словарь – минимум по религиоведению. М., Гардарика, 2000.
11. А.Мўминов ва бошқ. Диниунослик. Дарслик. Тошкент, 2004.
12. М.Абдуллаев ва бошқ. Мустақиллик: Изоҳли илмий-оммабон лугат. Тошкент, "Шарқ", 2000.
13. Миллий гоё: тарғибот технологиялари ва атамалар лугати(муаллифлар жамоаси). Тошкент, 2007.
14. У.Уватов. Муҳаддислар имоми. Тошкент, "Маънавият", 1998.
15. Karimov U. et al. USING NEW INFORMATION TECHNOLOGIES IN DISTANCE LEARNING SYSTEM //НОВАЯ ПРОМЫШЛЕННАЯ РЕВОЛЮЦИЯ В ЗЕРКАЛЕ СОВРЕМЕННОЙ НАУКИ. – 2018. – С. 9-11.
16. Vutaboev M. T., Karimov U. U. «ЗЕЛЁНАЯ ЭКОНОМИКА». МИРОВОЙ ОПЫТ И ОСОБЕННОСТИ РАЗВИТИЯ В УЗБЕКИСТАНЕ //Theoretical & Applied Science. – 2020. – №. 2. – С. 704-710.



LANGUAGE ANALYSIS OF LEXEMAS EXPRESSING FOLK CRAFTS

Jurayeva Nargiza Jamoliddinovna
Lecturer, Fergana State University

ABSTRACT

This article provides information on the terminological field and its role in the theory of the linguistic field. On the basis of factual materials the essence of the terminological field, its components, questions of their interrelation are covered.

KEYWORDS: *linguistic field, term, terminological field, abstract term, concrete term.*

DISCUSSION

As a result of the development of field theory in linguistics, its ideas and methods began to be applied to levels other than the lexical level of language. In modern linguistics, the concepts involved in the "field" component include: functional-semantic field, morphemic field, phonemic field, word-forming field, lexical field, semantic field, micro and macro field, relativity field, temporal field, number field, negation field, presence field, inclination field, personality field, lexical-grammatical field, transformational field, absolute (relational) field, field of activity, state field. Hence, field is a functional-semantic combination of units belonging to different levels on the basis of a common content or form similarity [5, 18].

According to the author of the research on the terminological field E.G. Petrosyants, all terms related to linguistics are functionally and semantically united, and this field occupies a special place in the general system of scientific terminology. The general system of scientific terminology is divided into two parts:

- a) a terminological field consisting of specific terms (such as names of plants, animals);
- b) a terminological field consisting of abstract terms (such as legal, economic, socio-political, pedagogical) [8, 6].

These views are specific to any terminological field, and in addition to this nominative (abstract/concreteness) criterion of terminological fields, there are also structural-semantic, structural-morphological criteria of other components. Based on this, we also distinguished between simple (primitive and artificial), compound, and compound

types according to the structure of the terminological field components. These components are mainly specific to the horse and quality category.

After the word expressing a particular concept was specialized, the term [9, 338], then the term, then rose to the level of a term. As a result of the formation of the science of philosophy, the father of science, specialized words related to it were called terminology, and the term has been used to refer to terminology. On the basis of philosophy, the development of other sciences, the development of professional fields has expanded the process of specialization, adaptation of meanings of words, and as a result, separate terms have emerged for each science and profession. These terms operate within a language. The term came into being in the process of their popularization, generalization, and comprehensibility to most peoples. This can be illustrated as follows:

The term is a terminological term

This indicates that it took a certain period of time for the words to rise to the level of a term.

The term enters the general lexical system of the language through a specific terminological system. Terminological field unit is a term that is a word or combination whose meaning is limited to these fields [10, 165; 1, 474].

In the terminological field, the following features are highlighted as a distinctive feature of the term:

- a) systematicity, the existence of differentiation;
- b) the tendency to monosemy in the field of terminology, ie a particular science, profession;
- c) lack of expressiveness [4];



g) methodological neutrality [11].

These features of the term apply only within the terminological field, and outside this field they lose the above properties.

The definition of the term concept is very diverse. In particular, in modern Uzbek linguistics the following views are formed: "the term is a word or combination used in the process of knowing and mastering certain objects that express professional meaning, express and form a professional concept and the relationship between them in terms of specific professions" [3, 76].

H. Narkhodjaeva describes the term as follows: "1) a term is a linguistic unit, word or combination belonging to the language of production, science and technology, which is a type of universal language that performs a special function;

2) term - a specialized name of a concrete thing-object, thing, abstract concepts;

3) a certain definition is needed for the term, which can more accurately express the content of the relevant concept, distinguishing one concept from another, while at the same time allowing to place a certain concept in a certain classification line, which can clearly show the distinguishing features" [3, 76].

T. Valiev: "... the units of the terminological system of the language are characterized not only by the mentioned general features, but also by their sectoral specificity. In particular, many terms used in the socio-humanitarian, economic-political, natural, exact sciences and technical-technological fields are distinguished by their distinctive features" [2, 16-17].

In this study, design terms were explored using the following methods and techniques:

1. Structural-morphological - analysis of simple (primitive and artificial), compound and compound terms, identification of their structural boundary differences.

2. To study the structural structure of transformational-terminological compounds.

3. To study the hyponym-hyperonymic properties of semantic-terminological substantive compound and basic and modifier components.

4. Valence is the determination of the productivity of the components of complex structural terms.

Structural and morphological features of the terminological field

The terminological field is divided into general terminological fields (non-generalized terms that do not belong to a particular field of science or profession) and specific terminological fields (non-generalized terms used only within a certain profession) according to the criteria of generality and specificity [11].

The general terminological field includes terms that have risen to the level of international terminology. For example, *atom*, *volt*, *morpheme*,

design, *golf*, *clash*, *hipster*, *lycra*. The private terminological field, on the other hand, includes territorially limited terms used only within one profession, and outside the terminological field they are treated as ordinary words. For example, *randa*, *honatlas*, *arqov*, *andoza*, *alacha*, *beqasam*.

The components of the terminological field are divided into concrete terminological fields (zoonyms, floronyms, natural phenomena) and abstract term fields (socio-political, economic, legal, etc.) according to the criteria of concrete and abstraction. In addition, terminological fields also differ in structural-semantic, structural-morphological criteria.

Structurally, we study the terminological field units in two:

1. Types according to morphological structure.

2. Types according to syntactic structure.

1. We divide the design terms of national fabric names according to their morphological structure into simple (primitive and artificial), compound terms.

The model of simple primitive terms in the field of design terms will be A (basis). Such terms are mainly from Uzbek, Arabic, Persian-Tajik and other languages. Including Uzbek: *alak*, *ip*, *alacha*, *doka*, *arqab*; Persian-Tajik: *abrishim*, *avra*, *adras*, *aybaki*, *kalava*, *kasana*, *kimxob*, *andaza*, *anjom*, *zar*, *band*, *bar*, *astar*; Arabic: *alvon*, *satin*, *sign*, *ornament*, *akbar*, from other languages: *bobrik* (Russian, long hair), *volta* (Russian, thin yarn), *gas* (Russian-French, thin, transparent silk fabric), *Maya* (Russian-Greek, thin yarn fabric), *marquise* (thin silk fabric), elegant and durable fabric, *nylon* (Russian-English, synthetic fiber and fabric woven from this fiber).

The model of simple artificial terms in the field of design terms will be A (base) + Af (additional). According to E.G. Petrosyants, the terms with the structural-morphological composition of the components of the terminological field A (basic) + Af (additional) entered the English language, mainly from the Roman and Greek languages [7, 6]. Such terms in the Uzbek language are Uzbek, Arabic and Persian-Tajik in origin. Including *ola + cha* (uzbek), *chok + chi* (uzbek), *cashmere + i* (f-t), *qudun + gar* (f-t), *naqsh + dor* (a + f-t), *chit + furush* (f-t) as.

It appears that the components of the terminological field also have a specific derivative property. In the Uzbek language, such terms are divided into three types:

1. A (Uzbek) + Af (Uzbek), ie terms with both basic and additional Uzbek. For example, *ola + cha*, *boz + chi*, *chok + chi*, *boya + chi*, *chit + chi*.

2. A (Uzbek) + Af (other), ie terms with Uzbek basis and affix of assimilation or vice versa. For example, *weld + chi*, *chit + gar*, *kalava + chi*.



3. A (other) + Af (other), i.e. both the base and the affix are terms derived from another language. For example, *gula + bardor (f-t)*, *gul + chin (f-t)*, *zar + bof (f-t)*, *zar + do'z (f-t)*, *adras + bof (f-t)*.

When studying the affixes that make up the terms of fabric design in the Uzbek language, the following active affixes were identified:

- chi*, (adraschi, painter, kudungchi);
- furush* (chitfurush, adrasfurush, paintfurush);
- ish* (ivitish, yigirish, quritish);
- lik* (astarlik, ko'rpalik);
- li* (andazali, ipakli, paxtali, zarli);
- siz* (ishlovsiz, andazasiz, bo'yoqsiz)

Of these, the -chi affix indicates the names of the fabric-making process, while the -li and -siz affixes indicate the presence or absence of a textile-specific character.

Uzbek textile design also uses Persian-Tajik prefixes: *be-* (*beandaza*, *beolchov*), *ser-* (*sernaqsh*, *serkashta*), *pesh-* (*peshband*, *peshgir*).

Joint terms also play an important role in the terminological field. In the field of design terms, the compound word becomes a model of the compound terms (A (basis) + A (basis)). In the Uzbek language in this case we can see the terms formed from the stems of only one language and from the stems of different languages: *homsurp (f-t)*, *haftrang (f-t)*, *gazchop (f-t)*, *gulkorpa (f-t)*, such as *wallpaper (f-t)*, *zardevor (f-t)*.

The above examples show that prepositive adjectives are used in Uzbek. The other two types are not available in Uzbek.

REFERENCES

1. Axmanova O.S. *Slovar lingvisticheskix terminov*. – Moskva: Sov. entsiklopediya, 1966. – S.474.
2. Valiev T. *O'zbek tili yo'lsozlik terminlarining struktur-semantik xususiyatlari va leksikografik talqini. Filol. fan. falsafa doktori (PhD) ... diss.* – Samarqand, 2018 – B.16-17.
3. Ko'chimov Sh. *Diplomatik til asoslari*. – Toshkent: O'qituvchi, 2006. – B. 76.
4. Mahmudov N. *Ilmiy matnda ekspressivlik ehtiyoji. Til va adabiyot ta'limi*. – Toshkent, 2018. – № 8.
5. Mirzaqulov T. *O'zbek tili morfem paradigmikasi va sintagmatikasi masalalari: Filol. fan. dokt. ... diss.avtoreferati*. – Toshkent, 1994. – B.18.
6. Narxodjaeva X. *Jarayon anglatuvchi terminlarning o'zbek tilida tutgan o'rni*. – Toshkent: Fan, 2013. – B. 11.
7. Petrosyants E.G. *Lingvisticheskoe terminopole: struktura, semantika, derivatsiya: na materiale angliyskogo yazyka: Avtoref.diss. ... doktora filol nauk*. – Pyatigorsk, 2004. – S.6.
8. Sobirov A. *O'zbek tilining leksik sathini sistemalar sistemasi tamoyili asosida tadqiq etish*. – Toshkent: Ma'naviyat, 2004. – B.136.
9. *O'zbek tilining izohli lug'ati. I tom*. – Moskva: Rus tili, 1981. – B.338.
10. *O'zbek tilining izohli lug'ati. II tom*. – Moskva: Rus tili, 1981. – B.165;
11. <https://www.ixbt.com/comm/sksterms.shtml>



COMPETENT APPROACH IN TEACHING PROBABILITY THEORY AND MATHEMATICAL STATISTICS

Toshboeva Saida Raxmonberdiyevna

Lecturer, Fergana State University

ABSTRACT

This article addresses competency issues, problems, and suggestions for teaching probability theory and mathematical statistics in higher education.

KEYWORDS: *competence, stochastics, fundamental principles, the principle of professional orientation of training.*

DISCUSSION

The current stage is characterized by high rates of scientific and technological progress, the emergence of fundamentally new progressive technologies, which determines the urgency of the quality of the educational process that meets the requirements of the modern world economy and international standards.

In the context of the practical implementation of modern methods of assessing the quality of education, the results of the international research PISA (Program for International Student Assessment) and in Uzbekistan, which revealed relatively low results of mathematical literacy of schoolchildren when using mathematical knowledge in non-standard situations that require creativity and intuition, as well as incompetence in solving problems using cognitive skills to solve interdisciplinary practical problems in which the solution is not clearly defined. The PISA conclusions link this problem, first of all, with traditional methods of checking the quality of education, which are limited mainly to checking knowledge, and not the ability to apply knowledge in a specific situation; and indicate the need to develop a competency-based approach in the formation of educational programs for higher pedagogical education.

When using the concepts of "competence-based approach", "competence" and "expertise" in pedagogical research, there are attempts to distinguish between their use. YES. Ivanov et al. [1] give the following interpretations of them:

- competence - a set of interrelated personality traits (knowledge, abilities, skills, methods of activity) assigned in relation to a certain range of objects and processes and necessary for high-quality productive activity in relation to them;

- expertise - possession, possession by a person of the appropriate competence, including his personal attitude towards her and the subject of activity;

- competence-based approach is an approach that focuses on the result of education, and the result is not considered the amount of information acquired, but a person's ability to act in various problem situations.

Modern trends in the development of society pose a system-oriented educational and upbringing goal for the higher school, the comprehensive implementation of which is aimed at training competent, creative specialists who are able to make informed and informed decisions in various situations, including random ones.

The existence in the world and society around us of an infinite number of both dynamic, statistical and random patterns, allows us to argue that modern specialists, who are the intellectual resource of society, must possess not only key competencies in the field of their professional activity, but also subject competencies in the field of random. [4]

The development of probabilistic thinking in students' learning process is complicated due to the difficulty of virtual perception of the mechanisms of random processes and patterns, as well as the lack of initial training in probability theory and mathematical statistics.



The educational process in higher education, including in probability theory and mathematical statistics, is subject to certain laws and principles of instruction. [5]

In modern didactics, a whole series of laws and laws of instruction are highlighted. The following regularities are formulated in the works of leading experts:

- conditionality of the learning process by the needs of society in highly qualified specialists of a wide profile, comprehensively developed and creatively active;
- the relationship of teaching and learning in a holistic learning process;
- the dependence of the content of training on its tasks, reflecting the needs of society;
- between subject links between different cycles of academic disciplines and between individual disciplines within a given cycle;
- The relationship between the educational and scientific activities of the student.

The most important regularity of the educational process in higher education is the regularity, which relates to subject relationships. Particular importance is given to the connection of fundamental disciplines with specializing majors. The requirements, which are based on the most important laws, are raised in the role of the principles of training. The patterns of learning are organically linked to the principles of learning, which are implemented both in the educational process as a whole and in its individual components.

Professional orientation in scientific and pedagogical literature is considered as a form of specific inter-subject communication and is characterized as a specialized relationship between general educational knowledge and professional knowledge (G.S. Gutonov, L.V. Melnikova, A.Ya. Kudryavtsev, N.N. Lemeshko, T. V. Voronin, T.N. Aleshin, etc.).

The principle of professional orientation involves the integration of general scientific and special disciplines at the university; general scientific knowledge with special knowledge and skills, as well as the formation of significant qualities of a future specialist. The essence of any teaching principle is revealed in the content of the contradiction to which it is directed. The principle of professional orientation resolves the contradiction between the requirements of society for the formation of a comprehensively developed holistic personality and the need for its preparation for active participation in a certain area of professional activity in accordance with personal interests, individual abilities, and social needs. [2]

The professional and pedagogical orientation of teaching mathematics is understood as the need for purposeful and continuous formation of the basics of professional mastery among students, based on active and in-depth knowledge of the school course of mathematics, its scientific foundations and methodological support, acquired on a favorable emotional background of a positive attitude to the profession of a teacher, to mathematics as to the subject.

Currently, in the didactics of higher education, six principles have been identified on which the concept of professionally-pedagogical orientation of education is based: fundamental, continuity, leading idea, binary, informatization, integrated approach (A.G. Mordkovich, G.L. Lukankin, N.I. Batkanova). [3]

Consider the possibility of implementing the principle of fundamentality in the process of teaching probability theory, the study of which is an organically integral part of the process of teaching mathematics.

The principle of fundamentality lies in the fact that the teacher must have fundamental mathematical training, providing him with mathematical knowledge that goes far beyond the school course of mathematics, and show erudition in the implementation of inter-subject relationships.

Students, as a rule, have a very meager baggage of school knowledge from the field of stochastics. In this regard, of particular interest are tasks that demonstrate the connection of probability theory with other sciences: physics, chemistry, biology, psychology, economics, etc., which clearly shows its interdisciplinary connections with other courses.

Obviously, for a better assimilation by students of the material throughout the entire course of study, special attention should be paid to the connection between learning and life, based on concrete examples. This will allow students not only to change their (by the way, quite common) attitude to probability theory as a science abundant in abstract concepts, but also to successfully apply their knowledge in practical activities.

Due to the fact that the course of probability theory is an important element of the methodological preparation of the future teacher, the variability of introducing basic concepts is of great importance. A comprehensive presentation of the material, a demonstration of various ways of introducing the same concept, and solving problems is necessary. For example: various definitions likely (classical, statistical and geometric); calculating the desired probability using various formulas and comparing the obtained values.

This approach to learning contributes to the formation and development of the student's ability to think abstractly, to freely navigate in various approaches to the study of material. When studying stochastics, it is useful to use algorithms to solve standard problems, as well as to form skills for self-compilation of algorithms, etc. In problems, it is necessary to draw students' attention to the relationship between scientific and practical



components, identify patterns that will allow us to build a mathematical model, and find an algorithm for solving.

As an example, consider the following task: In a batch of 10% of non-standard parts. Four pieces are selected at random. Write the binomial distribution law of the discrete random variable X - the number of non-standard parts among the four selected ones and construct the polygon of the resulting distribution. [6]

To solve this problem, the student must know about the law of distribution of a discrete random variable, i.e. what values does this random variable take? It takes values from 0 to 4:

X 0 1 2 3 4

But knowing this is not enough to fully understand this random variable. We must determine with what probability these values are accepted. To do this, we calculate these probabilities:

$$P(X = 0) = C_4^0 \cdot 0,1^4 \cdot (1 - 0,1)^0 = 0,1^4 = 0,0001$$

$$P(X = 1) = C_4^1 \cdot 0,1^3 \cdot (1 - 0,1)^1 = 4 \cdot 0,1^3 \cdot 0,9 = 0,0036$$

$$P(X = 2) = C_4^2 \cdot 0,1^2 \cdot (1 - 0,1)^2 = 6 \cdot 0,1^2 \cdot 0,9^2 = 0,0486$$

$$P(X = 3) = C_4^3 \cdot 0,1^1 \cdot (1 - 0,1)^3 = 4 \cdot 0,1 \cdot 0,9^3 = 0,2916$$

$$P(X = 4) = C_4^4 \cdot 0,1^0 \cdot (1 - 0,1)^4 = 0,9^4 = 0,6561$$

Check: $0.0001 + 0.0036 + 0.0486 + 0.2916 + 0.6561 = 1$

We write the desired binomial distribution law X:

X 0 1 2 3 4
P 0,0001 0,0036 0,0486 0,2916 0,6561

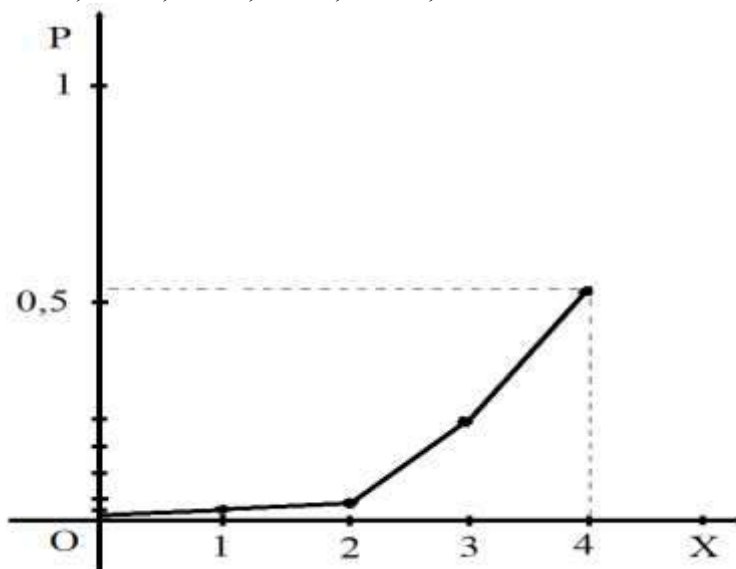

Let us construct a polygon of the obtained law, the distribution of a discrete random variable X-number of non-standard parts among the four selected ones.

After the student answers the questions of the examination card, the examiner asks the student additional questions. The teacher stops asking additional questions as soon as the student discovers not knowing the question asked. The probability that a student will answer any additional question asked is 0.9. It is required: a) to draw up the distribution law of a random discrete variable X - the number of additional questions that the teacher will ask the student; b) find the most probable number k_0 of additional questions asked to the student.

Slution. a) Discrete random variable X - the number of additional questions asked - has the following possible values: $x_1 = 1, x_2 = 2, x_3 = 3, \dots, x_k = k, \dots$ Let's find the probabilities of these possible values.

The X value will take the possible value $x_1 = 1$, (the examiner will ask only one question) if the student does not answer the first question. The probability of this possible value is $1 - 0.9 = 0.1$. So $P(X = 1) = 0,1$.

The X value will take the possible value $x_2 = 2$ (the examiner will ask only two questions) if the student answers the first question (the probability of this event is 0.9) and does not answer the second (the probability of this event is 0.1). In this way, $P(X = 2) = 0,9 \cdot 0,1 = 0,09$.

Similarly, we find

$$P(X = 3) = 0,9^2 \cdot 0,1 = 0,081 \dots \dots P(X = k) = 0,9^{k-1} \cdot 0,1 \dots$$

Let's write the required distribution law:

X 1 2 3 k .



$$p \quad 0,1 \quad 0,09 \quad 0,081 \quad 0,9^{k-1} \cdot 0,1$$

b) The most probable number k_0 of questions asked (the most probable possible value of X), that is, the number of questions posed by the teacher, which has the greatest probability, as follows from the distribution law, is equal to one.

The two guns are fired alternately at targets until the first hit by one of the guns. The probability of hitting the target with the first gun is 0,3, the second – 0,7. The first gun starts firing. Draw up the distribution laws for discrete random variables X and Y - the number of spent shells, respectively, by the first and second weapons.

Solution: The events A_i and B_i are empty - the first and second shells hit the target, respectively. The first gun will use up one shell ($X = 1$) if it hits the target on the first shot, or it misses, and the second gun hits the target on the first shot:

$$\begin{aligned} p_1 &= P(X = 1) = P(A_1 + \bar{A}_1 B_1) = P(A_1) + P(\bar{A}_1 B_1) = \\ &= P(A_1) + P(\bar{A}_1) \cdot P(B_1) = 0,3 + 0,7 \cdot 0,7 = 0,79 \end{aligned}$$

The first gun will use up two shells if both guns miss on the first shot, and on the second shot the first gun hits the target, or if it misses, and the second gun hits the target on the second shot:

$$\begin{aligned} p_2 &= P(X = 2) = P(\bar{A}_1 \bar{B}_1 A_2 + \bar{A}_1 \bar{B}_1 \bar{A}_2 B_2) = \\ &= 0,7 \cdot 0,3 \cdot 0,3 + 0,7 \cdot 0,3 \cdot 0,7 \cdot 0,7 = 0,21(0,3 + 0,49) = 0,79 \cdot 0,21 \end{aligned}$$

Similarly, we get

$$P(X = k) = 0,79 \cdot 0,21^{k-1}$$

The sought distribution law for a discrete random variable X - the number of shells consumed by the first weapon:

X	1	2	3	...	k	...
p	0,79	$0,79 \cdot 0,21$	$0,79 \cdot 0,21^2$...	$0,79 \cdot 0,21^{k-1}$...

$$\text{Control: } \sum p_i = 0,79 / (1 - 0,21) = 0,79 / 0,79 = 1.$$

Let us find the law of distribution of a discrete random variable Y - the number of shells consumed by the second weapon.

If the first gun hits the target during the first shot, the second gun will not fire:

$$p_1 = P(Y = 0) = P(A_1) = 0,3.$$

The second gun will use up only one round if it hits the target on the first shot, or if it misses, and the first gun hits the target on the second shot:

$$\begin{aligned} p_2 &= P(Y = 1) = P(\bar{A}_1 B_1 + \bar{A}_1 \bar{B}_1 A_2) = \\ &= 0,7 \cdot 0,7 + 0,7 \cdot 0,3 \cdot 0,3 = 0,21(0,3 + 0,49) = 0,553 \end{aligned}$$

The probability that the second weapon will use up two shells

$$p_3 = P(Y = 2) = P(\bar{A}_1 \bar{B}_1 \bar{A}_2 \bar{B}_2 + \bar{A}_1 \bar{B}_1 \bar{A}_2 B_2 A_2).$$

After completing the calculations, we find $p_3 = 0,553 \cdot 0,21$. Similarly, we get

$$P(Y = k) = 0,553 \cdot 0,21^{k-1}.$$

The sought distribution law of the discrete random variable Y - the number of the projectile consumed by the second weapon:



$$\begin{array}{ccccccc}
 Y & 0 & 1 & 2 & \dots & k & \dots \\
 p & 0,3 & 0,553 & 0,553 \cdot 0,21^1 & \dots & 0,553 \cdot 0,21^{k-1} & \dots \\
 \text{Control: } \sum p_i & = 0,3 + \left(\frac{0,553}{1} - 0,21\right) & = 0,3 + (0,553/0,79) = & & & & \\
 & = 0,3+0,7=1. & & & & &
 \end{array}$$

Thus, having analyzed the numerous views of scientists on the problem of competence and expertise, we can say that competence is not an indisputable and obvious phenomenon in educational culture. Competence is not just a set of knowledge and skills, but a whole system that binds them together. Whereas expertise is the ability of a person to self-actualize in any activity, including in the study of probability theory and mathematical statistics based on formed competencies. These concepts are multi-component, i.e. they include knowledge and activity and personal aspects.

LIST OF REFERENCES

1. Ivanov D.A., Mitrofanov K.G., Sokolova O.V. *Competence approach in education. Problems, concepts, tools: teaching aid. M. : APK and PPRO, 2005. - 101 p.*
2. Mordkovich A.G. *Professional and pedagogical orientation of the special training of a mathematics teacher at a pedagogical institute: Dis. ... dr ped. sciences. - M., 1986. - 355.*
3. A. Samsonova *Interrelation of fundamental principles and professional orientation of teaching probability theory and mathematical statistics of future specialists // Modern high technology. - 2010. - No. 8. - S. 146-149;*
4. Bunimovich E.A., Bulychev V.A. *Fundamentals of statistics and probability: 5–9 cells: A manual for educate. institutions. - M.: Bustard, 2004. - 288 p.*
5. Kobzar A.I. *Applied Mathematical Statistics. For engineers and scientists. a. M. : FIZMATLIT, 2006.– 816s.*
6. Gmurman V.E. *Guide to solving problems in probability theory and mathematical statistics. M., High School 1979. - 55-57s.*
7. Chubarev A.M. *Unbelievable probability. -M. : Znanie, 1976. -128 p.*
8. Shcherbatyx S. V. *In the world of stochastics (elective course): uchebnoe posobie. - E: EGU im. I.A. Bunina, 2011. - 148 p.*
9. Khankulov U. *Improving the pedagogical capabilities of teaching the elements of stochastic mathematics in academic lyceums. Autoref. Dis. ... doc. ped. fan.b. Toshkent 2018.*
10. Gafurova M.A. *Formation of mathematical competence in students by creating a new problem from the given problem. Khorezm "Ilm sharchashmalari" 2020 Issue 7, 5 p.*



THE DIGITALIZATION OF EDUCATION IN THE CONTEXT OF A NEW TECHNOLOGICAL GENERATION

Nurmatova Maftuna Ikhamova

Lecturer of Department "School Management", Kokand State Pedagogical Institute

ABSTRACT

The article deals with the issues of modern education in the digital economy. The author States that the digitalization of education is becoming the next stage in the technological development of education after informatization.

KEYWORDS: *digital technologies, digitalization of education, new technological generation, digital economy, key competencies, IT infrastructure*

ЦИФРОВИЗАЦИЯ ОБРАЗОВАНИЯ В УСЛОВИЯХ НОВОГО ТЕХНОЛОГИЧЕСКОГО ПОКОЛЕНИЯ

Нурматова Мафтуна Илхамовна

преподаватель кафедры «Школьный менеджмент»

Кокандский государственный педагогический институт,

Аннотация

В статье рассматриваются вопросы современного образования в условиях цифровой экономики. Автор констатирует тот факт, что цифровизация образования становится следующим за информатизацией этапом в технологическом развитии образования.

Ключевые слова: цифровые технологии, цифровизация образования, новое технологическое поколение, цифровая экономика, ключевые компетенции, IT-инфраструктура.

В настоящее время наблюдается тенденция стремительного развития информационно-коммуникационных технологий и их внедрения в экономику страны и жизнь общества. Президент Республики Узбекистан Шавкат Мирзиёев в своем Послании Олий Мажлису сделал особый акцент на важности научного и технологического развития. Он утверждал: «В целях устойчивого

развития мы должны глубоко освоить цифровые знания и информационные технологии, это даст нам возможность идти по самому короткому пути к достижению прогресса. ... Широкое внедрение цифровых технологий способствует эффективности государственного и общественного управления, развитию социальной сферы, одним словом, кардинальному улучшению жизни людей [1].



Для подготовки специалистов необходимо использование новых методов и технологий в обучении, которые должны лечь в основу национальной модели образования. Вопрос трансформации системы образования с целью приведения его в соответствие с требованиями новой реальности стоит сегодня очень остро. Президент Республики Узбекистан Шавкат Мирзиёев в своем Послании Олий Мажлису, объявив 2020 год Годом развития науки, просвещения и цифровой экономики, поставил задачу выполнения программы развития экономики нового технологического поколения, так называемой цифровой экономики. Решать эту актуальную задачу должны квалифицированные кадры, которые должны владеть новыми навыками, известными как компетенции XXI века.

В эпоху глобальной конкуренции необходимо сделать акцент на подготовке компетентных выпускников, готовых к сотрудничеству, сотворчеству, инновациям, обладающих критическим и аналитическим мышлением и способных эффективно решать реальные проблемы, что, в свою очередь, позволит выстроить стратегию по улучшению подготовки текущих и будущих специалистов.

Компетенции XXI века, по мнению Е.С. Мироненко, состоят из трех групп. Первая группа представлена основными или ключевыми компетенциями гражданина: грамотность, математика, научная грамотность и др. Во второй группе находятся генерация, обработка комплексной информации, общение, информация и идеи, решение проблем, сотрудничество, работа в команде и адаптивность к окружающей среде. Третью группу формируют компетенции с точки зрения информационно-коммуникационных технологий, или цифровые компетенции, к которым относятся технологические ресурсы и их умственное использование [2].

Цифровизация образования становится следующим за информатизацией этапом в технологическом развитии образования. Цифровизация предполагает, что в информационном обеспечении задействован практически весь объем вычислительных устройств, в том числе потребителей, которые, например, устанавливают мобильные приложения для того, чтобы воспользоваться услугами. Вовлечение большого числа устройств с возможностью подключения к интернету позволяет организовать сбор и обработку большого объема цифровых данных.

При переходе к цифровой экономике для успешной адаптации высших образовательных

учреждений к её условиям учёные предлагают такие меры, как обеспечение возможности обучения разным возрастным группам, гибкость в формировании и предоставлении программ, сотрудничество по обмену образовательным опытом, сотрудничество с бизнесом при формировании компетенций и учебных программ[3].

Необходимо обеспечить переход от информатизации образования к его цифровизации: от этапа фрагментарного применения информационных технологий в учебном процессе, укрупнения решаемых с их помощью задач, развития электронного обучения, оснащения вузов электронной *информационно-образовательной средой* (ИОС) и применения ее ресурсов в образовательной деятельности к этапу внедрения новых, цифровых технологий в учебный процесс. При этом основу цифровизации составляет созданная ИТ-инфраструктура и степень информатизации в учебных учреждениях.

Использование технологий даже в формате смешанного обучения помимо ИТ-инфраструктуры требует соответствующей подготовки преподавателей и студентов. Подготовка преподавателей к использованию информационных технологий в образовании, включающая обучение непосредственно работе с самими ИТ, должна быть дополнена обучением методической работе в информационном образовательном пространстве.

При этом необходимо отметить высокий уровень обеспечения вузов персональными компьютерами и доступом к интернету, а с другой, недостаток автоматизации административных и учебных процессов вуза. Несмотря на постоянное развитие технологий и появление новых образовательных веб-сервисов, а также государственную политику по формированию информационного образовательного пространства, его потенциал вузами задействован частично. Свидетельством тому может послужить онлайн обучение в условиях пандемии.

В современной системе образования Республики Узбекистан созданы необходимые основы по созданию ИТ-инфраструктуры, нормативно-правовому обеспечению практики в области применения информационных технологий в учебном процессе, которые должны стать основой для участия высших учебных заведений в цифровой экономике.



Использованные источники:

1. *Послание Президента Республики Узбекистан Олий Мажлису от 24 января 2020 года*
2. *Мироненко Е.С. Компетенции XXI века VS Образование XXI века . - М.: НИУ ВШЭ, 2018. 28 с. URL: https://ioe.hse.ru/data/2018/07/12/1151646087/2_19.pdf*
3. *Дадалко В.А., Соловкина Е.Д. Компетенции для цифровой экономики и трансформация образовательной системы в условиях VI экономического уклада // Национальные интересы: приоритеты и безопасность. – М.,2018*
4. *Стрекалова Н.Б. Риски внедрения цифровых технологий в образование // Национальные интересы: приоритеты и безопасность. – М.,2018.*
5. *Karimov U. et al. USING NEW INFORMATION TECHNOLOGIES IN DISTANCE LEARNING SYSTEM //НОВАЯ ПРОМЫШЛЕННАЯ РЕВОЛЮЦИЯ В ЗЕРКАЛЕ СОВРЕМЕННОЙ НАУКИ. – 2018. – С. 9-11.*



INHERITANCE AS A UNIVERSAL LAW OF DEVELOPMENT

Mamatov Obidkhon Vakkosovich

Head of the Department of National Ideology and Law Education, Namangan State University

ABSTRACT

In this paper, succession is analyzed as a universal law of development. In the article, Inheritance is interpreted as a philosophical category that represents the social transformation of society, the connection between times, the continuity in the transmission of material and spiritual wealth created from generation to generation.

KEYWORDS: *succession, social life, development, dialectical approach, contradictions, continuity.*

DISCUSSION

The application of the concept of inheritance to the sphere of society takes humanity from the world of blind necessity, to the world of freedom. "Inheritance is a philosophical category that represents the social transformation of society, the connection between times, the continuity in the transmission of material and spiritual wealth created from generation to generation." Because this understanding addresses the issues of how we should treat the past, what we should get, how we should develop, and determine how we operate with an understanding of the nature of the laws of development. Therefore, the first issue in the concept of inheritance is not what should be discarded, but what, how to take it away. Just as self-action is characteristic of dialectics, dialectical denial is also characterized by self-denial. This means that events arise in their own bosom, develop in their own bosom. Since the subject creates events at a higher level, in an improved form, development takes place through double negation. But even any series of denials does not represent dialectics. For example, grinding wheat and consuming it does not represent any dialectic. There is no process of self-denial here, and it is not peculiar to dialectics. If we affect a plant navigator, we can get a new variety from it. From what has been said, it is clear that the essence of the category of inheritance is to be sought only in the law of negation of negation. But this does not lead to the conclusion that there is no connection between the laws and categories of dialectics, on the contrary, because each law represents development in a certain

way, there is an integral connection between them. For example, Professor A.A.Abdurahmanov states that the concept of denial is related to the concept of contradiction: "Without a correct understanding of denial, it is impossible to understand the development of internal contradictions, the movement of objects from one state to another. Denial is the action and resolution of contradictions." It should also be noted that the resolution of contradictions is inherited in the course of subject events, where a violation of the "norm," that is, a quantitative boundary is violated, leads to a new qualitative state. This connection suggests that the laws of dialectics occur in the spontaneous, spontaneous development of an object, an event.

The laws of dialectics cannot fully describe development in isolation, but only represent different aspects. These laws complement each other. Its essence is that while the law of transition of quantitative changes to qualitative changes expresses development as a continuous process, succession means that development takes place as a continuous process.

One law alone is not enough to express development as a unit of continuity and continuity. This unity is expressed by the transition of quantitative changes to qualitative changes and the laws of negation together. The continuity of development is relative, and continuity is absolute.

In our opinion, it is appropriate for A.Sternin to connect the category of inheritance only with the law of negation. But it is incorrect to say that succession is only expressed as a moment of



progressive action. Because in the process of development, the old may retain the characteristics of the old, which leads to negative consequences. When talking about the relationship between the new and the old, time (s) should also be taken into account. If the old represents the past, the new represents the present. "In the context of the concept of dialectical denial, the peculiarity of the time is expressed, which constitutes the real history of its emergence."

The relationship of succession between the new and the old represents the connection between an object, an event in a qualitatively different state. In development, succession is expressed in such a way that in the process of denying object events, any new object becomes an event, not a new object, which is a self-denial, that is, it recovers itself in an improved form. We can give an example from any field to prove this point. For example, at least if we consider Charles Darwin's theory of evolution, we can see in it remarkable examples of succession. In the formation of biological species, the new species denies its predecessor, but retains many of the characteristics of the old species. Inheritance is a law that applies not only in nature, but also in society and the development of knowledge.

Inheritance has a common feature as a law, but since this commonality is manifested in a unique way in each process, each area needs to be analyzed from a specific perspective. In nature itself, we can consider different forms of inheritance. For example, if we look at different levels of evolution of matter, inheritance in the inorganic and organic worlds is different. Inheritance in the organic world itself can be conditionally divided into several species. Because it is made up of organisms, plants, animals and animals. Since the object of our research is not the manifestation of inheritance at different levels of matter development, we will not dwell on them in detail.

The purpose is simply to emphasize that inheritance is manifested in concrete forms. It follows that succession in social development and natural development are radically different. Present nature, however, is the result of the world's evolutionary development of the world over millions of years, of which society is a part. Although society is a part of nature, it is qualitatively different from the lower forms of nature. The reason for this difference is the moment of inheritance. "Inheritance is of great importance not only for the biological form of being, suffice it to say that without internal inheritance there is no progress at all, but only a simple sum of changes that make room for each other." The fact that the organic world came into being from the inorganic world proves in itself the importance of inheritance and its objectivity. Inheritance is not something people invent. Since

they do not yet have an understanding of inheritance, nature has evolved on the basis of inheritance millions and even billions of years ago. The development of all spheres, that is, nature, society, and thought, represents the generality of inheritance, and the fact that it is repeated at all times, its stability. These features prove to be legitimate along with its other features. Although society is separated from nature on the basis of inheritance, historical (social) inheritance is qualitatively different from inheritance in nature. In nature, blind forces act, while in society, conscious people operate. But because neither society nor nature came into being out of nothing, they both have their own past and future. How the present and the future develop determines the nature of succession. When he reconsiders the life of society, he cannot give up all that he has inherited from the past, first and foremost, he uses the means of production. For example, after gaining independence, Uzbekistan did not give up the means of production. Perhaps on its basis, economic relations have changed rapidly. Raising economic relations to a higher level requires raising ideological relations, first of all, political and legal relations. In the development of economic relations, we have set the main goal of market relations, the denationalization of property, the creation of a class of owners. But achieving this goal was not an easy task. As noted above, while inheritance has a general character, it manifests itself in specific forms. We have adopted the concept of private property as inheritance. But the process of its formation was carried out taking into account the specifics of socio-economic conditions. The emergence of a new economic system begins with the creation of a political and legal basis, changing people's attitudes to property. The transition to a market economy is not just a renewal and improvement of the management system, but a transition from one quality state to another. Market economy relations have taught us a great lesson in this regard. But our market relations are different. The ideas of development and succession are inextricably linked. One cannot be explained in detail without the other. Without taking into account the peculiarities of the way of life in our Republic, our market relations, it is impossible to properly shape the future and the ideology of this people. So, in solving the problem of inheritance, this connection should be a matter of principle. Chaloyan has rightly admitted this. "Development can only take place on the basis of inheritance, and the problem of succession cannot be imagined without taking into account the specificity of development." If we pay attention to the policy pursued by the President of the Republic, the policy of the government, every reform carried out in society, we will see that our society is working with this in mind. Peace in the republic is



the result of such an approach to every issue. When talking about inheritance in social life, one cannot help but dwell on its relationship with inheritance. Because the concepts of inheritance and inheritence are close and different from each other, misunderstanding them leads to misunderstandings. People never give up the material and spiritual riches they have acquired. But they are forced to change the form of social relations so as not to lose that result. In the field of history, inheritance is different from the concept of inheritence in general. Historical inheritence is inextricably linked with the conscious activity of people. The concept of inheritence represents the necessary connection between the new and the old. Inheritance is the sum of the wealth created by the previous generation, the previous period, and represents the attitude of the current generation towards that wealth. "The concept of heritage implies an understanding of the laws of inheritence, the appreciation of the cultural riches left by past generations and their creative assimilation."

The concept of inheritance is mainly used in relation to spiritual culture. But inheritance also represents an attitude towards material wealth.

Many authors understand the need to analyze the relationship between the concepts of inheritance and inheritence when studying the problem of inheritance. Because our main theme is ideology and this ideology must come from our cultural heritage of the past

we will also need to consider the relationship between inheritance and succession. We have considered the concept of inheritance above. Inheritance expresses our attitude towards our past heritage from the point of view we are looking at, that is, how we treat our past culture, especially our spiritual culture. M. Khairullaev and D. Shorahmedov defines the concept of cultural heritage as follows: "Cultural heritage is a set of material and spiritual riches left to humanity from the past and critically approached, creatively reconsidered, developed and used on the basis of specific historical tasks and objective criteria of social development."

In the formation of ideology, the concepts of inheritance and succession have a complex character, because ideology is not something that is formed by itself. The role of subjective factors in the formation of ideology is invaluable. What are these factors? This is primarily due to the improvement of the social order of society, the existence of different parties, the influence of different ideological currents on the human mind, as well as the position of the thinker who promotes the emerging ideology, its goals and objectives, level of knowledge and a number of other factors. . Thus, the problem of inheritance has been formed since ancient times and has reached its perfection today. The relationship

between the past, present, and future was viewed by the Greek philosopher Aristotle as a connection (although he did not use the concept of inheritance). But the examination of hereditary relations was still in its infancy in the ancient Greeks. Aristotle comes very close to the concept of inheritance in his analysis of the concepts of development, change, movement.

The role of medieval Central Asian thinkers, especially Farobi, in the formation of the concept of succession is incomparable. Although he also did not philosophically analyze the concept of inheritance, in his works he approached the issues of nature and social development from the perspective of inheritance. Therefore, important signs of succession can be found in the works of Farobi. In this sense, it cannot be said that Farobi had no influence in the development of Gegel's concept of succession.

An in-depth philosophical analysis of the concept of succession can rightly be said to apply to Hegel. In developing the laws of dialectics, Gegel, in particular, in the statement of the law of negation, analyzes the concept of succession as a law.

But even though Farobi did not express succession at the level of legitimacy, he can provide an in-depth analysis of the relationship between the old and the new and its importance in society.

In modern philosophical literature, including Uzbek philosophical literature, various aspects of inheritance, types of inheritance are described. In them we encounter different approaches. But in the vast majority of them, inheritance is given as a general law of the development of nature, society, and thought.

The following conclusions can be drawn from the above considerations:

From 1, inheritance is an important form of connection between old and new.

From 2, some of the features of the old will be repeated in the new in its improved and perfect form.

From 3, inheritance is an important condition for development.

4, Inheritance is the most important law of development, that is, the law that applies in nature, in society, and in the field of thought.

Inheritance is a general law of development of being, including spiritual being.

LITERATURE

1. Tukhtaev H. *Continuity in the cultural heritage and its social significance. Social sciences in Uzbekistan.* №4, 1997.-B. 77.
2. Abdurakhmanov A.A. *Dialectics of continuity in the development of spiritual culture. T.:* 1990.S. 13.
3. Khayrullaev M., Shoraxmedov D. *Culture and heritage. T.:* 1973-B. 1b.



4. Чалоян В. К. *Восток и Запад* изд. Наука. М.: 1968-С.5.
5. Кремянский В. К. *Обсуждению философских вопросов современной генетики //Вопросы философии.* 9/1970.С.133.
6. Стрелченко. В.Н. *О диалектике преемственности в процессах отрицания химического биологическим// Современный дарвинизм и диалектика познания жьзни.* Л.:1985-Б. 183-184.
7. Fannarov Э. О. *INNOVATION, SOCIAL INNOVATION AND INNOVATION ACTIVITY: SCIENTIFIC AND THEORETICAL APPROACHES //Scientific Bulletin of Namangan State University.* – 2019. – Т. 1. – №. 10. – С. 152-157.
8. Talarov B., Gapparov E. *THE PROCESS OF DEMOCRATIZING LOCAL COMMUNITY IN THE GOVERNMENT //Scientific Bulletin of Namangan State University.* – 2019. – Т. 1. – №. 2. – С. 177-181.
9. Ismoilov T. I. *SOCIAL AND LEGAL SOLUTIONS OF INSURANCE MANDATORY RECOMMENDATIONS //Scientific Bulletin of Namangan State University.* – 2019. – Т. 1. – №. 3. – С. 152-154.
10. Хаджиев, У. Ш., мақсади ёшларда тафаккурни шакллантиришида Шарқ, Т., Курбаниязова, Р. К., Айтбоев, М. Ю., Турсункулова, Ш. Т., Исмоилов, Т. И., ... & Примов, Б. А. *Ёшларнинг тафаккурини шакллантиришида шарқона маънавий-ахлоқий императивларнинг ўрни. Образование,* 8(9), 10.
11. Ismoilov T. I. *UNIQUE FEATURES OF WORKING WITH UNORGANIZED YOUTH //Экономика и социум.* – 2018. – №. 2. – С. 28-30.
12. Ismoilov T. I. *PROVISION OF INFORMATION-PSYCHOLOGICAL SECURITY IN OPEN INFORMATION SYSTEMS //Теория и практика современной науки.* – 2018. – №. 1. – С. 24-26.
13. Ismoilov T. I., Umarov I. *NECESSITY AND IMPORTANCE OF USING NEW PEDAGOGICAL TECHNOLOGIES IN HIGHER EDUCATION //Теория и практика современной науки.* – 2018. – №. 3. – С. 28-30.
14. Исмоилов Т. И. *ЗАДАЧИ ФОРМИРОВАНИЯ ИДЕОЛОГИЧЕСКОГО ИММУНИТЕТА В ПРОЦЕССЕ ГЛОБАЛИЗАЦИИ //Теория и практика современной науки.* – 2017. – №. 5. – С. 328-330.



ON THE IMPORTANCE ABOUT CULTURE IN LEARNING FOREIGN LANGUAGES

M.Habibullaev

Master student, Namangan State University

ANNOTATION

The article attempts to tell about the importance of culture in learning foreign languages. Since the mid-1960s, more pragmatic educational goals have become requirements. After reforms in education, it is in foreign language lessons that the ability to communicate, that is, communicative competence and equality in communication, became the leading educational goals. However, the knowledge of people's culture is necessary for successful communication in any language.

KEY WORDS: *Reforms in methodology, communication ability, listening skills, speaking, reading, writing, communication functions, cardinal improvement, information and communication technologies, lifestyle, worldview, values, culture*

О НЕОБХОДИМОСТИ ЗНАНИЯ КУЛЬТУРЫ В ПРОЦЕССЕ ИЗУЧЕНИЯ ИНОСТРАННЫХ ЯЗЫКОВ

М.Хабибуллаев, магистрант

Наманганский Государственный Университет

Аннотация. В статье предпринята попытка рассказать о значении культуры в процессе изучения иностранных языков. Отмечается, что с середины 1960-х годов требования по обучению иностранных языков стали более прагматичными. После реформ в образовании именно на уроках иностранного языка умение общаться, то есть коммуникативная компетентность и равенство в общении, стали ведущими образовательными целями. Но для успешного общения на любом языке требуется быть хорошо знакомом с культурой этого народа.

Ключевые слова: Реформы в методике, коммуникативная способность, навыки слушания, разговор, чтение, письменная речь, функции общения, кардинальное совершенствование, информационно-коммуникационные технологии, образ жизни, мировоззрение, ценности, культура

Изменения, происходящие в обществе в настоящее время и процессы глобализации не обошли стороной методику обучения иностранным языкам. Реформы в методике

обучения иностранным языкам, которые начались давно в зарубежных странах, то есть в 70-х годах XX века, сейчас происходят в нашей стране. Требования к содержанию образования растут.



Учащийся, проявляющий большой интерес к уроку иностранного языка, может иметь низкую коммуникативную способность (способности), даже если он или она хорошо разбирается в правилах грамматики. Это потому, что иностранный язык рассматривается как языковая система, а не как средство общения. В этой статье мы хотим выделить понятие «коммуникативная компетентность», которое важно в методологии обучения иностранным языкам. Концепция коммуникативных способностей уходит корнями в социальную философию и была придумана Никласом Луманом и Юргеном Хабермасом. Ганс Эберхард-Пьело ввел теорию Хабермаса в дидактику иностранных языков.[1] Коммуникативная способность теперь определяется как способность, которая, помимо прочих способностей, делится на четыре: навыки слушания, разговор, чтения и письменная речь. Понятия «цель речи» и «общение» также происходят из теории Хабермаса. Этот новый подход к процессу изучения языка приводит к следующим выводам: - Языковые выражения больше не основываются на формально-грамматической категории, а на коммуникативной функции. Например, выражение желания является коммуникативной функцией, и этот процесс осуществляется различными средствами речи, то есть фраза «я бы хотел» может быть выражена через конъюнктив «Ich möchte gern» или «Ich hätte gern». - Усовершенствование учебной программы соответствует функциям общения, а не грамматике. По этой причине, учащиеся смогут выучить фразу «Ich hätte gern» до прохождения Conjunction в учебной программе. - Не очень важно соблюдать грамматические правила в процессе обучения иностранному языку. В процессе свободного выражения идей больше внимания уделяется способности учащегося выразить правильную идею из содержания. В общении важна гармония: ученик должен уметь не только правильно говорить, но и использовать в общении разные социальные слои языка. Лучше сказать другу «Vielen Dank», чем «Ich bin dir magic verbunden». Используется только для объяснения на родном языке. Важно знание языка. Эти факторы получили название «коммуникативный поворот». До сих пор преобладали требования образования, в котором иностранный язык рассматривался как средство формирования духовности и личности учащихся. Однако с середины 1960-х годов эти требования стали более прагматичными целями обучения. После реформ в образовании именно на уроках иностранного языка умение общаться, то есть коммуникативная компетентность и равенство в общении, стали ведущими образовательными

целями. Достижение коммуникативных навыков стало неотъемлемой частью процесса формирования личности студента; он включает не только изучение иностранного языка человеком, но и его способность к общению. Пренебрежение изучением иностранных языков и этнографии, существовавшее до сих пор, должно быть прекращено. При изучении иностранного языка основное внимание уделялось повседневным моделям общения. Более поздний межкультурный подход позволил изучать иностранный язык, чтобы отличать одну культуру от другой. Кроме того, изучение средств и форм речи, относящихся к повседневным жизненным ситуациям, ведет к сознательному пониманию собственной культуры. Цель коммуникативного подхода - научить учащихся общаться в межкультурных ситуациях. Важную роль в этом играет формирование у студентов способности сравнивать культуры. Они должны сначала научиться не торопиться оценивать непонятные ситуации и события в другой культуре на основе их собственных культурных норм. Сравнение культур заключается не в оценке «хорошо» или «плохо» (на основе критериев), а в понимании различий. Одна из следующих целей обучения иностранному языку - развитие способности понимать представителя другой культуры.

В результате масштабных реформ на всех этапах системы образования сотни тысяч наших юношей и девушек изучают иностранные языки по всем специальностям нашей страны и в филиалах вузов других стран. После обретения независимости республика открыла путь к диалогу со всеми зарубежными странами, а масштабы и скорость обмена информацией растут. Появляется огромный спрос со стороны престижных организаций и фирм. Конечно, для работы в таких организациях требуется работа персонала, свободно владеющего иностранными языками, поэтому количество вузов, стремящихся обучить персонал в соответствии с международными стандартами, с каждым годом растет. В настоящее время возможно кардинальное совершенствование системы обучения подрастающего поколения иностранным языкам и совершенствование системы подготовки специалистов, свободно владеющих иностранными языками, развитие международного сотрудничества и диалога в данной сфере за счет внедрения передовых методов обучения с использованием современных педагогических и информационно-коммуникационных технологий. Для этого создаются условия и возможности. Известно, что язык формируется и развивается в обществе. Язык - зеркало духовной жизни народа, сердце



нации. Уважение к языку - это всеобщее уважение к народу и нации. Знание языка имеет решающее значение для понимания мира. Если человек хочет хорошо выучить другой иностранный язык, он должен сначала знать, уважать, любить, ценить его чистоту, красоту, достоинство - важнейшая из национальных ценностей. Очень важно знать историю, культуру, обычаи, литературу и искусство людей на их родном языке. Поэтому способность говорить на языках, отличных от их родного, повышает их мировоззрение и духовность. Каждый язык по-своему уникален. Невозможно хорошо знать язык, пока не усвоить преимущества изучения языка. Поэтому для человека, в совершенстве знающего свой язык, естественно легко начать изучать другие языки. Так же, как и наш язык, другие языки отражают прошлое людей. Изучая разные языки, человек не только понимает себя, но и узнает об образе жизни, мировоззрении, обычаях, ценностях и жизни других народов.

В начале 21-ого века ученые начали изучать возможность и важность внедрения изучения культуры в процесс обучения языкам. Ставшая трендом коммуникативная модель, часто пренебрегает культурой и в основном уделяет внимание к другим аспектам языка такие как лексика, синтаксис, фонетика и др. Хотя, культура народов говорящих на языке имеет огромную роль в понимании этих людей и является важным фактором для успешного общения. «Обучение культуре должно позволить учащимся расширить свои знания о целевой культуре с точки зрения образа жизни, ценностей, взглядов и убеждений людей, а также того, как они проявляются или выражаются в лингвистических категориях и формах. В частности, преподавание культуры должно знакомить учащихся с речевыми актами, коннотациями, этикетом, т. е. уместным или несоответствующим поведением, а также предоставлять им возможность действовать как член целевой культуры. Обладая знаниями о том, что такие понятия, как «высшая» или «низшая» культуры, являются не чем иным, как широкими обобщениями, происходящими от недостатка знаний и неуважения к другим людям с другим мировоззрением, учащиеся могут углубиться в изучаемый язык и использовать его как инструмент, а не только для того, чтобы общаться в стране, в которой на нем говорят, но также для того, чтобы дать второй (или третий) голос их мыслям, тем самым бросая вызов культурным традициям и стереотипам.» (Thanasoulas).

Исследование, проведенный Генш и Бада, показали, что «культурный класс является значительно выгодным с точки зрения языковых навыков, повышение культурной

осведомленности, изменение отношения к родным и целевым общества и вклад в профессию учителя. Участники этого исследования подчеркнули некоторую трансформацию своего мышления и перечислили шесть пунктов как потенциальные вклад культурного класса, который они получили. Это исследование имеет значение для урока культуры в учебной программе языкового обучения. Включенный в учебную программу урок культуры является жизненно важным компонентом изучения языка и преподавания, поскольку, как показывает это исследование, может помочь развитию коммуникативной компетенции, а также других навыков в обучение на любом языке.» (Genc, Bada.)

Исходя из всего этого можно сказать, что обучение культуре должно стать неотъемлемой частью процесса обучения иностранным языкам. Это во-первых, поможет более качественному усвоению иностранных языков, а во-вторых, лучшему пониманию других народов, что позволит избежать различные недоразумения и недопонимания, а также улучшить процессы межкультурных диалогов.

Список использованной литературы

1. Алисия Педрос. Маркус Бихеле. Дидактика *Landeskunde*. Berlin. «Langenscheidt 2003.-160S
Рогова Г. В. и др. Методика обучения иностранным языкам в средней школе. Москва Просвещение, 1991.-286 с. Fiehler, Reinhard (2005):
2. *Gesprochene Sprache*. B: Duden. Грамматика. Auflage.Mannheim: Dudenverlag. Деннерманн, Арнульф (erscheint): *Verstehen im Gespräch*. B: Кемпер, Хайдунг; Эйхингер, Людвиг М. (Hg.) *Sprache - Познание - Культура. Sprache zwischen mentaler Strukturund kultureller Prägung*. Fiehler, Reinhard (2003): *Каковы основные принципы Sprache? B: Sprachtheo*
3. Dimitrios Thanasoulas. *The Importance Of Teaching Culture In The Foreign Language Classroom*. (2001) *Radical Pedagogy* ISSN: 1524-6345.
4. Bilal Genc and Erdogan Bada . *CULTURE IN LANGUAGE LEARNING AND TEACHING. The Reading Matrix*. Vol. 5, No. 1, April 2005 .
5. Farxodjonqizi F. N., Dilshodjonugli N. S. *Innovative processes and trends in the educational process in Uzbekistan //ACADEMICIA: An International Multidisciplinary Research Journal*. – 2020. – T. 10. – №. 4. – С. 621-626.
6. Farxodjonova N.F. *HISTORY MODERNIZATION AND INTEGRATION OF CULTURE //Теория и практика современной науки*. – 2018. – №. 3. – С. 13-15.
7. Farxodjonova N. F. *MODERNIZATION AND GLOBALIZATION AS HISTORICAL STAGES OF HUMAN INTEGRATION //Теория и практика*



- современной науки. – 2018. – №. 3. – С. 16-19.*
8. *8. Numonjonov S. D. Innovative methods of professional training // ISJ Theoretical & Applied Science, 01 (81). – 2020. – С. 747-750.*
 9. *10. Ergashev I., Farxodjonova N. Integration of national culture in the process of globalization // Journal of Critical Reviews. – 2020. – T. 7. – №. 2. – С. 477-479.*



THE ROLE OF MUSIC AND MUSIC EDUCATION IN THE SPIRITUAL AND MORAL EDUCATION OF YOUTH

Qahramon Bobokulov

Senior lecturer of the department "Musical education", Jizzakh State Pedagogical Institute

ANNOTATION

This article highlights the important tasks of inculcating in the minds of our youth today the splendor of the great treasure of our national values and traditions, ancient culture and art and music, passing them from generation to generation.

KEY WORDS: *music, music education, classical music, national values, culture, art, popular culture, globalization, spirituality, ethics.*

DISCUSSION

Today, it is important to integrate into the minds of our youth the polishes of our national values and traditions, the great treasure of ancient culture and art, leaving them from generation to generation is one of the tasks. Elements of "mass culture", which arose and deepened in the era of globalism, have a negative impact on the worldview of young people. As a result, many young people are constantly using in their way of life not only masterpieces of ancient folk culture that have historically existed, but also products of a unique cultural world with a modern appearance, unusual interpretation.

The supernatural cultural manifestations entering our cultural life have a negative impact on the youth's deep understanding of the specific national culture, national character and moral - spiritual outlook of our people. As a result, problems are being raised in today's society in solving the task of assimilation of young people with high universal and national moral values, which is of paramount importance as it becomes an important tradition of their own lives.

In the solution of these problems in the spiritual and educational world of young people, the program tasks determined in the society and the measures taken by it highly relevant. President of our country Sh.Mirziyov noted in his appeal to the Oliy Majlis, "the constant raising of the spiritual and educational level of the population, especially young men and girls in our society of primary importance. Therefore, on the basis of the program idea" from the national revival – towards the national upsurge", the upbringing of young people in the spirit of loyalty to the native land, the

formation of initiative, self – sacrifice, moral qualities in them very honorable task.

All manifestations of national folk art, artistic culture, artistic aesthetic values, music and classical art, which have been bleaching for millennia on the territory of our country, have become the cornerstone of spiritual perfection of man and society. The development of society over the centuries has also influenced the development of modern lifestyle, literature, art and culture of the people. Cultural development in turn affected the development of the art of music. A.Avloni said: "all the arts and crafts of the nations that have developed, die in the shadow of a lesson in the knowledge and vision, and have done the world a great deal of Munawar and musahhar."

The art of music has served as the development of man as a cultural subject in the Society of personality, the understanding of the logic of life and life, the organization of relations at the cultural level, the spiritual level of society. Philosophy as noted in the encyclopedic dictionary, "music is of great importance in the perception of reality in the spirit of special tenderness, sensitivity, sincerity, it expresses the mental state of people, their inner world, their lives, their feelings in unique subtle ochanges."

The art of music and the teaching of music in all types of education is a process in which young people are important in mastering national spiritual and moral values. Foreign songs and music entering the life of young people in today's modern processes, songs that are created on the basis of foreign music, far from professional skills, absolutely incompatible with the culture and art of the Uzbek people, provoking the anger of people, are absolutely supernatural processes



that undermine our national and classical singing culture, spiritual values and absorb it from Philosopher Alim A.Saitkasimov said that "the retreat from our national traditions in youth, the lack of respect, the blind imitation of Western culture, the manifestation of the manifestations of egocentrism, self-conceit and individualism are situations that should attract the attention of the public".

The first president of our country I.Karimov noted that "some young performers consider such indecent actions as clips that absolutely do not correspond to our national traditions, rules of conduct, mixing words in different languages or deliberately breaking the pronunciation to be a new style for themselves, in my opinion, nothing more than not understanding art, its essence and significance. Our cultural community, first of all musicologists, teacher artists, composers, writers and journalists, countless art lovers openly express their views on such issues, thus giving the right education to our young people, I think that both debt and obligation".

In this dependent and non-destructive situation, teaching in the subjects of culture, art and music requires the teacher to have a high level of professional skills. It is important that the teacher, along with the reference to the students of the existing materials in the art of music, teaches it in a way that is harmonized with spiritual education. The pupil and student should be a master educator to integrate the national classical art palette and through this form the national cultural skills. Therefore, the music teacher should deeply master the history and theory of the music of the Uzbek people, deep understand them, analyze them, acquire high performance skills. The music teacher is also a deep promoter of our national music art.

Today, in the education, it is in demand that only skillful teachers who understand the art of music, who are able to behave as an artist. The teacher of music in educational activities should be able to skillfully convey the classical art of our people to the reader, embody humanism and high spiritual potential, formulate positive professional and pedagogical qualities. In music lessons, the professional and pedagogical qualities of the teacher should be formed from the concepts, principles, concepts, criteria of universal and national morality. Because, "the source that sustains the stability of spirituality in the soul, spiritual world of the individual, gives strength to every thought, behavior, attitude and action of the individual, calls for great deeds is literature and art."

In promoting the art of classical music among young people, the musical-aesthetic education in the family is also an important process. The cultural environment of the parents, the older generation, the close relatives, their ways, the cultural lessons they give are also of great importance in the preservation of classical art, integration into the worldview of the younger generation. It is necessary for parents to

carefully monitor how their child walks in the cultural world, how much he is singing or listening to music, watching clips or movies, in this respect, they should perform the role of a psychologist, a subtle pedagogue. They give a great impetus to the formation of a generation that has reached spiritual perfection, if the child increases his interest in classical art and national culture and creates conditions for their educational development.

The system of tasks of formation of the spiritual worldview of young people in musical education is as follows:

1. To teach classical music samples to the minds of students and students, which are the core of moral and spiritual values that exist in society in music lessons.

2. Formulate the students the ability to fully understand and understand the words of classical music in each of the lines, correctly pronounce them, understand their educational content and be able to analyze their practical characteristics.

3. Formation of experience and skills in teaching students to respect and love the art of classical singing and status, to express the tradition of promoting them in their professional activities.

4. Formation of knowledge on the oral creativity of the people, the art of giving and the main vision in the students, awaken a feeling of love for national values in the educational content of music lessons, increase their pride, pride and pride.

5. By introducing the readers with the rich cultural heritage of our people, to increase their aesthetic consciousness and artistic taste, to increase the aesthetic level of artistic amateur;

6. To draw the attention of the general public to the work of educating young people, who are respectful of the national musical art, who are fond of it, who are ready to protect it, to feel himself as a real responsible pupil, who serves to increase the spirituality and culture of society.

REFERENCES

1. *Ўзбекистон Республикаси Президентини Шавкат Мирзиёевнинг Олий Мажлисга Мурожаатномаси. 24 январь 2020 йил. www.uza.uz.*
2. *Абдулла Авлоний. Туркий гулистон ёхуд ахлоқ. -Тошкент, "Ўқитувчи", 1992. -29.*
3. *Фалсафа қомусий лугат. Тошкент, "Шарқ", 2004. -Б. 357.*
4. *Сайтқосимов А. Миллий гоя ва ижтимоий барқарорлик. -Тошкент, Тафаккур, 2014. -Б. 33.*
5. *Каримов И. Юсак маънавият енгилмас куч. -Тошкент, Маънавият, 2008. -Б.98.*
6. *Ризаев Ш. Изтироб санъати: адабиёт, театр, кино, музика. -Тошкент, Янги аср авлоди, 2013. -Б. 26.*



EXPRESSION OF SOCIAL NORMS IN THE WORK OF JADID THINKERS

Berdikulova Surayyo Aslamovna

*Senior Lecturer, Department "Civil society and law education",
National University of Uzbekistan named after Mirzo Ulugbek*

ANNOTATION

After gaining independence, attention was paid to the study of the activities of the jadids. It is known that they sought to achieve such a goal as the creation of a democratic society, the protection of the citizens' land, their rights, mainly the formation of a national statehood and its governance.

KEY WORDS: *social norms, jadid, philosophy, spirituality, behavior.*

DISCUSSION

In particular, one of our great enlighteners Abdulla Avlani's work "Turkiy Guliston yohud axloq" is of great importance at a time when our centuries old values and high spirituality are being restored. The game comprehensively focuses on such concepts as morality, behavior, good behavior, bad behavior, upbringing, morality, discipline, faith, justice, envy, oppression, which are structural elements of social norms. Everyone who calls people to good and tries to return from evil, and for this, says that everyone is responsible, and the educator should be an example. In particular, "If a person in his youth his soul is broken, ill-bred, grew up in dirt, "Allahu Akbar", to wait for good from such people, to stand up from the Earth and stretch out your hand to the stars is a nightmare... He created the gilub, who distinguished the true people with talent and talent, good and evil, good and harm, and white and black in his original form. But this ability in a person is shared by upbringing to perfection." [1] Through training, a person begins to maintain the norm in his activities, through which he confesses that certain problems will find their solution. These ideas are important in any period we consider.

Another co-founder of the Turkestan movement, Mahmudkhaja Behbudiy, has set himself the goal of preserving the homeland from danger in conditions of crisis and stagnation, ignorance and injustice, educating generations in the spirit of freedom, initiating enlightenment and development. In his

pessimism "Padarkush or the state of an uneducated child", it is the immorality and ignorance that makes us crumbly, unselfish and impoverished: impoverishment, impoverishment, complication, impoverishment and humiliation are all the fruits and results of ignorance and neutrality. The people who have developed into the world develop by means of science... As long as we are ill-educated and do not teach our children, plenty of bad deeds and misfortunes must always reign among us. There is no other way than to read and read these works to extinction. [2]"

Behbudiy, like his other comrades, believes that justice can not be established until the nation acquires freedom, independence. In human activities, justice, equality criteria are considered important.

Also, another of the great manifestations of our national spiritual heritage is Munavvar Qori Abdurashidkhanov. In the section "Moral lessons" of his treatise "Adibus-soniy", a person who says "I will be kind" will look at everything with self-esteem and receive self-esteem. Whichever work is good to the eye, ul tries to do the job. And if selective work looks bad on the eyes, tartur himself from ul work. A person who does this, of course, will be polite." [3]... "It is necessary to fold the good deed to the friend and the enemy. Because a good word will make friends of friends. Turns your enemies into friendships" [4] he says.

Observing the creativity of the Munavvar Qori Abdurashidxonov, he pays special attention to the



norms of morality, which are in the system of social norms. In particular, in order to get rid of bad habits, vices, members of society, it is necessary first of all to study and correct the reasons for them, and to emphasize the importance of theatrical curses in this. Knowing that the problem of a nation is the meaning of its own life, it considers its development as its main objective.

Another of the manifestations of Jadid, Abdurauf Fitrat, in his work "Adabiyot qoidalari", in which he confesses about the rules of writing, procedures, in his work "Oila yoki oila boshqarish tartiblari" in the socio-educational direction, "the happiness and glory of each nation depends, of course, on the internal discipline and harmony of this people. And peace and harmony rely on the discipline of the families of the same nation. Wherever a family relationship relies on strong discipline, the country and nation are both so strong and orderly. If the inhabitants of a country weaken their family relations with dirt and ignorance and allow indiscipline, then the happiness and life of this nation will remain in doubt," [5] he says.

Abdurauf Fitrat from his above views it is known that the basic principles of moral norms in the system of social norms are of great importance for the development of society. Upbringing in this way is recognized as the main criterion.

What do we need from mahmudkhu'ja Behbudiy's follower, Haji Muin, in his newspaper "The sound of workers" on August 13, 1918, "knowing the ground and time of the present (allowing) mooses, the protection of our rights and lives, the need for the taste of our future," says the title in his article "What need for us" [6]. And in the article "Family education" on July 9, 1918, "there is no nation that has developed in the world, let his family remain ill-educated. Or that there is no family, that his Aphrodite will not be brought up, that he will live with true happiness... Muslims have developed and embraced husni under the shadow of morality and family education." [7]

Haji Muin also emphasizes family education on the principles of moral norms, just like Abdurauf Fitrat. On the basis of the same upbringing, it is believed that society develops, moral qualities are formed and developed.

In general, in the work of accelerators, on the basis of language norms, moral, legal, political norms in the system of social norms, the principle of freedom, education and humanization took the main place. In particular, "manifestations of jadidism," [8] - argues philosophicologist A.Choriev believes that the main condition for the humanization and democratization of public life is the transformation of the socio-economic

system existing in the countries of Central Asia, in particular, the reconstruction of the country's management, the achievement of national independence, and it is necessary to start reforming such a noble task, the educational system. Of course, the manifestations of the jadid movement Homeland and the nation, those who dreamed of seeing society at a highly civilized level, and in achieving this, they drew all their attention to such issues as the radical renewal of schools and madrasahs, the development of education and upbringing, relying on moral norms. Those who carry out their activities together, in cooperation, try to absorb national pride. Those who sought to protect the muslims of Turkestan within the framework of the laws of that period.

REFERENCES

1. Авлоний, Абдулла. Танланган асарлар: 2 жилдик. 2-нашири. 2-жилд. Пандлар, ибратлар, ҳикоятлар, набийлар ҳаёти, драмалар, мақолалар, саёҳат хотиралари //Тахрир ҳайъати: Н.Каримов ва бошқ.; Тўпловчи: Б.Қосимов; Изоҳлар ва лугатни О.Тўлабоев тузган/-Т.: "Маънавият", 2006.-Б.34-35
2. Беҳбудий М. Танланган асарлар.//Тўпловчи, сўзбоши ва изоҳлар: Б.Қосимов.- 3-нашири, тузатилган ва тўлдирилган.-Т.: "Маънавит", 2006.-Б. 50.
3. Мунаввар қори Абдурашидхонов. Танланган асарлар // Тахрир ҳайъати: О.Шарафиддинов, Н.Аминов, Н. Каримов ва бошқ.: Маъсул муҳарир: Н.Каримов.-Т.: "Маънавият", 2003. –Б.74.
4. Мунаввар қори Абдурашидхонов. Танланган асарлар // Тахрир ҳайъати: О.Шарафиддинов, Н.Аминов, Н. Каримов ва бошқ.: Маъсул муҳарир: Н.Каримов.-Т.: "Маънавият", 2003. –Б. 76
5. Фитрат, Абдурауф. Танланган асарлар. Ж.ІV. Дарслик ва ўқув қўлланмалари, илмий мақола ва тадқиқотлар.-Т.: "Маънавият", 2006.-Б.215.
6. Муин, Хожии. Танланган асарлар. –Т.: "Маънавият", 2005.-Б. 86.
7. Муин, Хожии. Танланган асарлар. –Т.: "Маънавият", 2005.
8. Чориев А. Инсон фалсафаси.1-китоб.-Т.: "Маънавият", 1998.-Б. 152.



USE OF PERCEPTION MAP IN NATIVE LANGUAGE LESSONS

Ergasheva Muhayyo Valijonovna

Assistant of Professor

Kokand State Pedagogical Institute

ANNOTATION

In this article, the mastering layer in language education is considered to be a special phenomenon and constitutes a significant part of the dictionary layer. Recommendations for the use of the map of perception in the teaching of vocabulary are given.

BASE CONCEPTS: *education, education, Uzbek language, assimilation layer, Arabic words, Persian words, innovation, perception map.*

DISCUSSION

It is known that the issues of training competitive personnel for the educational sphere remain one of the urgent tasks. It was considered necessary to further improve the sphere of continuous education, increase the opportunities of quality education services, continue the policy of training highly qualified personnel in accordance with the modern needs of the labor market.

Like other areas of education as a result of the stated opinions, language education is rapidly developing and improving. In language education, the assimilation layer is considered a special phenomenon and forms a significant part of the dictionary layer. Initial information about the word self is given in general secondary education, later in higher education. About the mastered layer in school education there is information in the 5th grade. Understanding of the mastered layer requires great skill from The Specialists of the field to integrate the consciousness of the reader, to formulate the skills to be able to use them correctly, if necessary.

It is known that there is enough theoretical information about the mastered layer, scientific analysis. However, the methodology of teaching the subject related to the mastered layer, the studies on teaching them are few.

The lexical development of the Uzbek language can also be studied on the basis of stages of a certain period, taking into account significant changes in society. The Uzbek language, which is considered a Turkic language, has historically been in use for the peoples of the Central Asian region for several centuries at the same time as the Persian

(Tajik) language. Language omission as a result of prolonged communication has significantly affected the lexical layer of both languages. In the lexical layer of the Uzbek language, new words, Persian isophas, phrases, and even word-building suffixes were introduced. Such words, first of all, mavhum, and then many of them, like the words of their stratum, adapted to our language and settled in an unstressed position. As a result, assimilation words began to enter into a synonym, antonymic, graduonymic, hyponymic relations in the process of centuries-old speech.

After the arab invasion, which began in the VII-VIII century, along with the influence of Islamic culture, a layer of religious-educational concepts, first of all, and then Arabic words with wide coverage, entered our lexicon. As a result of the great attention of the population to the Islamic religion, enthusiasm and interest in the Arabic language, the Arabic language among our people has risen to the level of Science and education. As a result, the Arabic language in its time served as the language of Science-an international language for peoples based on Islamic culture.

Among the words assimilated from the Arabic language, there are also lexemes such as literary, artistic, triumphal, real, family, which are historically fictitious.

Historical changes that began in the life of society in the XIX-XX centuries began to be reflected in the language. This period was an accelerated period of the process of assimilation of words and the withdrawal of words from consumption. In the XX century, the establishment of



schools, the mass literacy, the publication of newspapers and magazines further accelerated this process. An important feature of this period is that when not only Russian words entered our language, but also many English, Chinese, French, Spanish words entered through the Russian language, a large number of Persian-Arabic words in our lexicon became nouns or left out of consumption.

The 20th century was the age of rise for Uzbek linguistics. The creation of textbooks of the native language, research on the theory of linguistics, the beginning of publication of scientific journals, the emergence of scientific articles, candidate and doctoral dissertations, the publication of philological and encyclopedic dictionaries are considered a huge heritage created by Uzbek linguists.

After independence, the position of the Uzbek language, especially in the socio-political, spiritual life, in the conduct of work in government agencies and in the Press, increased its importance. Special attention was paid to the productive use of the beautiful opportunities of our language, showing its expressiveness, attractiveness, bringing words and phrases generalized internationally in various fields in accordance with the legislation of our language.

One of the active and effective tools in interactive learning is the perception map.

A map of perception is a way of presenting any process or phenomenon, idea or idea in a complex, systematized, visual (graphical) form.

Mind-maps (the term can be translated as "perception map", "mind maps", "thoughts map", "thought Maps") is a graphic representation of information on a large sheet of paper. The map reflects the relationships between concepts, parts of the area under consideration, and properties (content, cause and phenomenon, associative, etc.). It is more understandable than to describe these thoughts in writing with the help of words. After all, through the word, I extract a lot of unnecessary information, forcing my brain to work in a way that is not unique to it. As a result, this leads to a loss of time, a decrease in attention and rapid fatigue. Although we met examples of the creation of maps of the first perception in scientific works written in the previous centuries, their wide application began in the second half of the twentieth century due to the English psychologist Tony Byuzen. The effectiveness of perception - maps is explained by the fact that it is similar to the process of thinking in a person. The map of perception can be imagined as a picture of the complex and depressing interactions of our thoughts, and this allows our brain to sort and detail the objects and phenomena. When using perception-maps, we try to draw our own thinking process.

Perform exercises on the determination of Arabic assimilation.

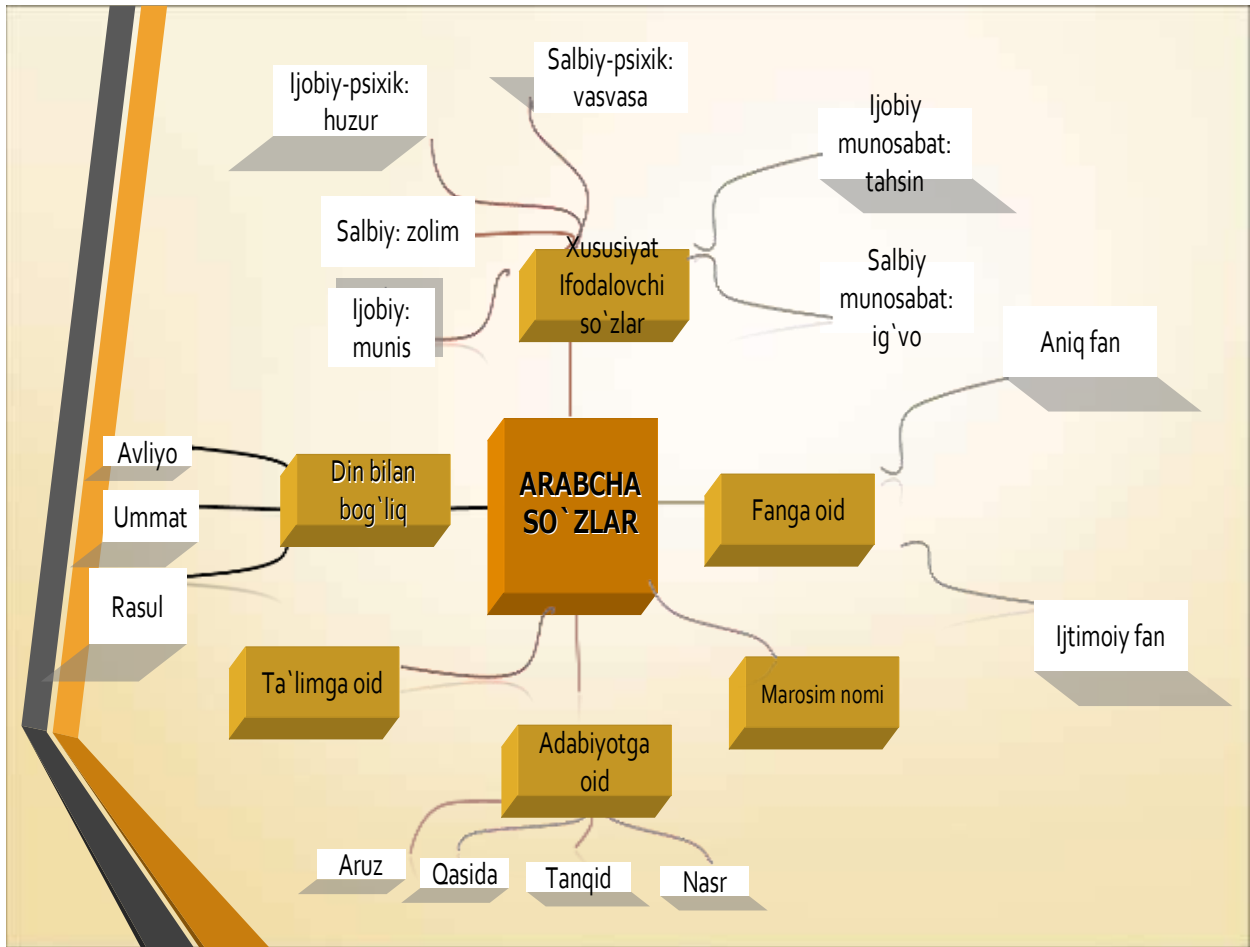

Perform exercises from the surface to determine the Persian assimilation

Uzbek oyim did not go to the wedding for a while - she said: "my Junction is not left on the street". Therefore, if the wives had held their wedding with the participation of Uzbek oyim, they would have listed themselves as one of the happiest wives of the city and said, "I spent my wedding with my own hands." The reputation of Uzbek oyim was not only limited to alone, but also respected by the ladies of the orda and knew her as their "mothers". Accordingly, at some time the yasovul of orda made a cross-carriage to the door of Yusufbek Haji and expected Uzbek oyim month to be built as "Orda begi Ayim was ordered". At what meetings with this side, Uzbek oyim would also take away the memories of her wives: "yesterday, when the orda came to me, I returned the cart empty without going

to spoil character... Vo, God, if the miss orda was a janitor, I would say. The second time: "I went to the orda the other day; the ladies did not put you to bed, I unwittingly went to bed one night," the word went between them.

(Abdulla Qodiriy, "Utkan kunlar")

Completion: from the text it follows that such words as 1 -, 2 - the sentence, junction in pitcher, reputation, god, night are Persian words. At the end of the word, such words as gusht, musht (sht), daraxt, baxt (xt), barg (rg), from which the double consonant came, passed mainly through the persian-tajik language.

3-Assignment:

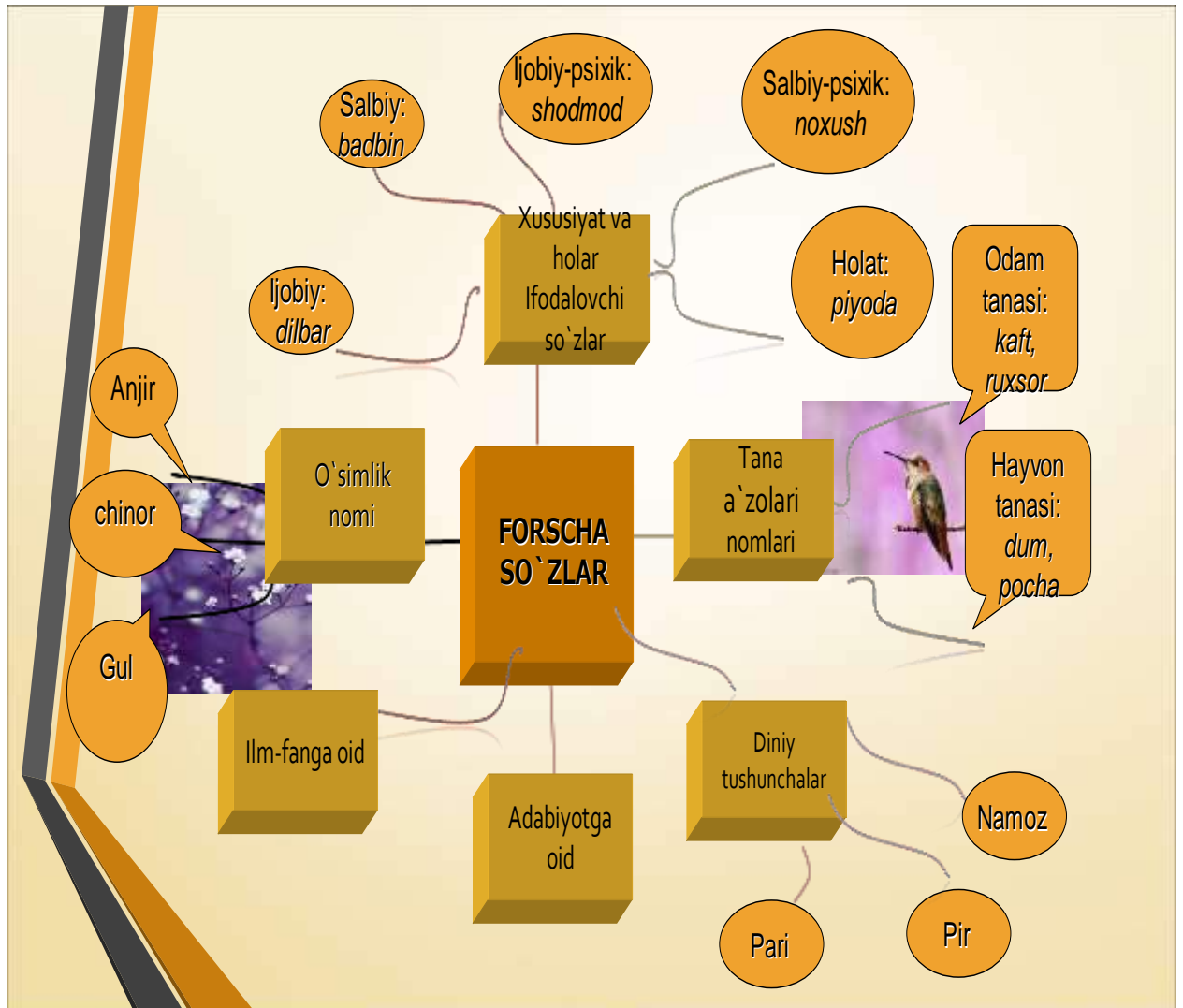

The "map of perception" method is a method of graphically describing a subject or educational material, allowing systematic, orderly and visual mastering of information. The "perception map" is an effective factor in systematizing, perfectly preserving them in memory, demonstrating the causal attachment of parts of technical devices with a complex structure that carries out technological processes. In it, the more detailed analysis of this educational material will allow to determine in advance how much attention will be paid to the first-level educational material as widely as possible.

REFERENCES

1. Ishmuhamedov R.J. *Innovatsion texnologiyalar yordamida ta'lim samaradorligini oshirish yo'llari*. – T.: TDPU, 2005.
2. Ishmuhamedov R. J. va boshqalar. *Tarbiyada innovatsion texnologiyala T.: O'zbekiston Respublikasi Prezidentining "Istedod" jamg'armasi*. 2010.
3. Golish L.V., Fayzullayeva D.M. *Pedagogik texnologiyalarni loyihalashtirish va rejalashtirish: O'quv uslubiy qo'llanma/ Innovasion ta'lim texnologiyasi seriyasi*. – T.: "Iqtisodiyot" 2012. – 156 bet.
4. Saidaxmedov N.S. *Yangi pedagogik texnologiyalar*. – T.: Moliya nashr, 2003.
5. Jim Burke. *The English Teacher's Companion*. Heinemann; 4th edition. 2012. - 392p.



NOVERBAL MEANS EXPRESSING THE VERBAL PERSONALITY

Hojaliev Ismoil Tojibaevich

Candidate of philological sciences, Associate Professor, Fergana State University, Fergana, Uzbekistan

ANNOTATION

In the article, nonverbal tools such as gestures, behavior, low voice, tone, timbre, mimic, gaze, representing the speaker's personality in the speech process are studied.

KEYWORDS: *language system, Speech System, thought process, speech process, nonverbal means, information transmission, speech pace, speech situation.*

DISCUSSION

The conversational process is a multifaceted phenomenon. Because speech is formed on the basis of thinking of verbal and nonverbal means. In the process of speech, language, spirituality, contemplation and physiologic, even other systems that are outside man, enter into an autoresponder relationship. Therefore, the language is an open system. On the basis of the language system, the speech system is formed.

And the speech system works with derivatives, which have their own physical, material scale, serving for a personal communicative purpose, dressing with the help of units selected from different types of small language systems. Units of the speech system actually come into being as a result of the fact that the possibility of obtaining uzoro birika, which exists in the nature of different types of language units, is generated by millions (1.24). In other words, "language is a possibility, and speech is to some extent the occurrence of this possibility" (1. 25).

Language is the product of the process of thinking of a person, and at the same time, this is also the form of this process. The process of thinking of a person has a two – sided essence, which is considered to be its logical and abstract nature, and these two aspects fulfill the task in the quality of a communicative medium (2. 11). because the fact of being, which has its own expression in the language, being formed through reflection, is the substantiation of the concept content, while the chain of sounds systematized using the language is the substantiation of expression (3. 146). Language abstract system is an

invariant essence, which is manifested in unlimited variants when it becomes materialized. This process is manifested in the colloquial act. And the speech act consists of a unit of nonlinguistic (nonverbal) means with linguistic means. In the study of the conversational process, only the analysis by separating the verbal means into its own, prevents the analysis from being perfect and complete. Especially in studies related to the verbal personality, nonverbal means can not be put aside.

Nonverbal means are tools that are outside the language, but have a special place in speech. Such tools are used in the process of speech as gestures, behavior, high-pitched voice, melody, timbre, mimicry, gaze, etc.:

I do not know how much I slept. When I open my eyes, Umarali stands on top of me.

– You're not doing that, said Umarali comfortably somehow in a tone.

Said Ahmad. "Kirpikda qolgan tong" (4. 25).

The guy looked sadly at the girl's strangled face in the sun of cancer.

– My parents were not there...

The girl suddenly became loose. "It's okay if not," said the disillusioned jilmaygan tune, shaking the head and heading towards the gate.

A.Ibodinov. "Kul buyida"

The role of the verbal means in the transfer of information, in the expression of thoughts can not be overestimated. This case is of great importance, especially in written speech. Because, in written speech, information is transmitted directly (through writing). The reader (listener) enters into communication with the writer (speaker) through writing. Usually the writer and the reader do not communicate face to face.



Because when standing face to face, there is no need for writing. Therefore, as the most effective means of information transmission in written speech, language units—verbal means—occupy an important place. In colloquial speech, however, in the process of oral communication, nonverbal means are able to express such a verbal personality as language, his opinion, attitude, occupy a special place in the process of communication (4.71-74). According to N.I.Farmonovskaya, 7% of the opinion that people themselves wanted to say in the process of conversation was explained by the word intonation, the remaining 38% by the tone and 55% by the sign. What is included in the list of nonverbal tools and what function do they perform during communication? Such means include, first of all, the state of the speaker during communication. The status of the speaker at the moment of communication ensures that the conversation is understandable and effective. To do this, the speaker must behave freely, simply and sober in the conversation. The situation of the speaker, who keeps himself uncomfortable during the conversation, expresses his inner excitement, composure and distrust of himself, indecision:

Kamolnkhonov, waiting for the answer to the request "hop", the phone rang while the question was still in the haze. Head of section Sulaymonov received the pipe.

- Labbay.....ha....ha...a? Vah-hah-ha-ha....

Why, Kamolnkhonov also laughed and sat quietly on the chair, adjusting his figure.

Abdulla Qahhor "Ikki yorti bir butun" (5. 294)

In the presented excerpt, Kamolnkhonov's behavior shows that he feels uncomfortable in front of the leader, is excited about how the leader reacts to what he is talking about, and also shows that he is a person who is leaning on the Chiefs. And Sulaymonov shows that he ignores the person who is standing in front of him.

If the speaker holds himself very freely, breaks from the level of the norm, makes the impression that the listener is pessimistic, the character is light, does not feel responsibility at the required level. The same situation of the speaker finds its expression in his speech:

- Pleasing – that buzzing Mullah Soat. – Your knowledge is good, Chori. The madrasah of the lands you study is salty.

From this sentence, the face of the Mullah Chorus flowed, the cheeks shook and the poison shook:

"This needs to know, Mawlono Soat," he said

. - Muni knows that the ass is wrapped in turban.

Mullah Soat laughed, then:

– I mowed down the mullah, who did not follow his knowledge, – he speak.

Murad Muhammad Dust "Galatepaga qaytish" (6. 24)

Such words as "his face flowed like a wolf", "his cheeks trembling", "laughed" cut "in the excerpt, vocabulary and non-verbal means expressed in the phrase, together with the creation of a portrait of the speaker in the speech act, denigrate his character, temperament and, at the same time, the hidden features of his character, in a certain situation. And the fable of sighing reports that the speaker does not believe in himself, has a gift during the conversation, has a low status from the interlocutor, etc.

The height and intensity of the ovz from the nonverbal means also have a specific role. If speaking out loud means disrespect to the listener, then the voice represents humiliation, reprimand. The loud timbre sound quickly touches the instrument. It is considered a sign of anger or muteness:

– The mouse will be eleven kilo of cotton wool, which in one day fell into the nest! shouts director. - Look at your body! Your ass shouts out of your body! Die, to this day! Look at me, when do you fulfill the norm?! Say, when, when, when, when!..

Togay Murod "Otamdan qolgan dalalar" (7.54)

Lexical-semantic tools such as "body", "die", "tell" in the fragment, repetition of word (when), second-person conjugation with zero form, morphological tools such as the-san form, and intonation, expressed by the verb "shout", denote the height of the speaker's position, as well as the disregard of the listener and the non-observance of moral rules, do not know the conversational mood of the speaker at the same time

Speech tempo and speed also ensure the efficiency of information transmission. In particular, speaking too slowly puts the listener bored. In this case, information loses its value.

In the speech act, the speaker himself, his views, behavior also give information about the character of the speaker, the state of his speech situation:

Gaybarov's anger provoked, he looked at the mullah first.

- Hit, okay, hit!.. - Mullah Soat of that rooster. –So even if you do not respect my age! They said that the bad boy would spoil the country, the same rumor, you are also breaking the country!.. – He got up, taking the knot lying on the edge of the table.

Murad Muhammad Dust "Galatepaga qaytish" (6. 28-29)

In general speech, along with linguistic means, nonlinguistic means also occupy a great place. It is not only that he understands the idea, but also gives information about who the speaker is, his position in society or a certain group, his purpose, morality, or by filling out and clarifying similar information expressed by linguistic means.



REFERENCES

1. Нейматов Х., Бозоров О. *Тил ва нутқ. –Т.: Ўқитувчи, 1993.*
2. Колианский Г.В. *Коммуникативная функция и структура языка. –М.: «Наука», 1984.*
3. Нурмонов А. *Лингвистик таълимотлар тарихи // Нурмонов А. Танланган асарлар. 3 жилдлик, 2-жилд, Т.: Akadempnashr, 2012.*
4. Хожалиев И. *FarDU. Ilmiy xabarlar- Научный вестник. ФерГУ. 2017, № 5.*
5. Саид Ахмад. *Киприкда қолган тонг, –Т.: Шарқ, 2008.*
6. Абдулла Қаҳҳор. *Асарлар: 5 жилдлик, 1-жилд, –Т.: Адабиёт ва санъат нашриёти, 1987.*
7. Мурод Муҳаммад Дўст. *Галатепага қайтиши, –Т.: Адабиёт ва санъат нашриёти, 1983.*
8. Тоғай Мурод. *Отамдан қолган далалар. – Т.: Шарқ, 1994.*



INTERPRETATION OF NATIONAL CHARACTERS IN THE NOVEL "UTGAN KUNLAR" BY ABDULLA QADIRI

Sabirdinov Akbar Gafurovich

*Associate Professor, Department of Literary Studies, Doctor of philological Sciences (DSc),
Fergana State University*

ANNOTATION

In the article explores the manifestation of Abdulla Qadiri in the cards, which reflected the image, character, instant state and actions of the national hero and personages in the novel "Utgan kunlar". The writer's skill in ensuring image compactness, expression viability, interpretation accuracy is illuminated.

KEY WORDS: *novel, skill, scene, hero and personage, character, interpretation and image, status and action.*

INTRODUCTION

The article aims to study the skills of Abdulla Qadiri to create national images and characters in the novel "Utgan kunlar". The writer creates vivid, vital, touching heroes through the means of instant images, circumstances, behavior of the heroes, they reveal the nationality of their character. As a result, the interpretation and interior of the heroes are ravaged in harmony. It turns out that the writer's unique style of expression in the use of the word compactly, selectively.

The famous French writer Andre Morua wrote in his article "Honore de Balzac" that the most important feature of Balzac's work is that he not only left us many novels, but that his novels are the history of an entire society. The people involved in his works are doctors, lawyers, statesmen, merchants, usurers, noble women, satans, who move from volume to volume. This makes the universe created by Balzac more bubbly and more reliable. However, when Balzac began to write his first works, he had not yet devised a plan for his future glorious epic."^[1]

The novel of Abdulla Qadiri "Utgan kunlar", as he himself pointed out "... the most dirty, black days of our history, from the past, from the future "Khan times", is considered an informative work. The creation of this masterpiece has been almost a century, and still amazes the people of science, the broad masses of readers with its excellent content and form, unique images and personages, thorough plot and composition, distinctive visual expressions and tools, high artistry and language construction.

Each episode, instant situations arising from the sensitive pen of Abdulla Qadiri, arise on the basis of visual means and expressions, the essence of the work, the interpretation of the characters, as well as the fulfillment of a certain ideological, artistic and aesthetic task are served. Creative finds in the novel, various details that are the product of vital observations play an important role in the integrity of the image in the images of the hero and the personages.

Abdulla Qadiri eastren, the master of creating national images and characters, creates unique heroes who are brought up on the basis of morality. They face, think, whether positive or negative, as a child of the nation of their time. Opinions about the main heroes go to the interpretation sometimes through the description of other personages, and the holistic lines of the inner and outer portrait are manifested. For example, if the son of Yusufbek Haji, one of the famous nobles of Tashkent, who listened to the opinion of Otabek, came to the conclusion that the Ziyu shohigi is "the child of his father", then Akram Haji" let his life be long, he is the most intelligent among our young men...", "If I had the hand to raise the Khan, I would have raised the Otabek by the hand..."he will evaluate. Mirzakarim qudidor said "as long as God has given everything", "as long as the Otabek is a guy worthy of Khan's daughter ", "if the bridegroom is so...", "I would consider myself one of the happiest fathers if I could achieve the honor of making a young man a son like Otabek."

The Ziyu shohigi about Homid, who is famous for his nickname "khotinboz" and not for his wealth, explains that "our Homidboy is a wounded man for



such shading remarks," and his wives say, "If he died in Kokand, would we feel sorry for the dead dogs?". Hasanali described Homid as "a dark-skinned young man."

This is how the writer consistently informs about a particular hero and the stable aspects of his character through the speech of other personages.

In the "Chaqimchilik" chapter of the novel, the state of Homid, who decided to lead a scoundrel over the Otabek and Mirzakarim qutidor, "in the same time was seen signs of savagery, the predator of his tone, the brutality that was put on the attack of a sinner. In each case was ul tracks plans, even if not some of the good roads to a revelation. In the end, irony was seen on his face, but he made an act as if he had put it up to something, and he jumped up and took his dirty handkerchief in the pile and went out into the yard,"[2,50] expressed in the way.

The writer points out that through the interpretation of the dirty in the pile, Homid was engaged in carrying out dirty work. The status of "sinners" who were shocked by the sins of the Uttaboy qushbegi, which had been laid upon them, was "when Otabek was strangled, and the qutidor began to tremble from malaria"[2, 59].

It becomes clear that the release of the "culprits" caused by the letter of Yusufbek Haji, who brought Kumushbibi, sent from Tashkent to Otabek. And the situation of the qurboshi, who is a partner of Homid, is reflected in the way "the qurboshi also sat down on the left side of the qushbegi, where he as did not lost his bag, going to the top of the Kumush"[2,79].

In a number of images in the novel, such as Yusufbek Haji, Mirzakarim qutidor, Uzbek oyim, Oftob oyim, Otabek, Kumush, Hasanali, Zaynab, master Alim, Saodat, we see high samples of eastern morality. This is the result of Abdulla Qadiri's long observation and quest for character creation. For example, when the Ziyoy shohigi and Hasanali realize that they do not give their lonely daughters to a stranger and do not send them to Tashkent, Mirzakarim qutidor with fair comes to the matchmaker. Mirzakarim qutidor, in turn, is also ashamed not to tell the "thin" matchmakers of the rejection answer. This situation was "Unharmful for the good of the Qutidor. Not only in the qutidor, but also the matchmakers were unharmful. To the subtleties of the matter, the three were also understandable and therefore went to a deep silence as if making an alliance"[2, 34].

The second family built on the surface of the obligation, the Otabek, who became an "inanimate statue" under the Zaynab, the young bride-Zaynab, who in the hope of loving the Otabek, embarrassed by the cold attitude of the groom to the bride, the cases of the Uzbek oyim are reflected in the follows:

"Having written on the table, lunch came tea. He threw bread into the bowl of Uzbek oyim and waited for his bride, that is, at the door. When the bride saw through the door, she put her son looking as if he had said "Resist". Seventeen youth, hundred of grayness, snow-white face, average beauty. Zaynab came to the table by pressing one by one with his mother's - in - law wishes and dignified modesty. After the permission of the mother-in-law to "sit", and sit, without making a sound, strangling. In the eyes of Uzbek oyim in his son. If the son had been eating bread mules for tea. Although one or two looked at your son frowned upon again, he was forced to solidify the word on him after he could not meet his eye:

- Your charla did not even become, if you go and see your father-in-law. Or can you see without charla?

Zaynab was able to sew her eyes to her husband. Otabek cool replied to her mother:

- I can see... - he said and looked with smile to Zaynab. Zaynab was also laughing. This little smile calmed Uzbek oyim again. But stressing with reason in the competition, again entered the boyag silence. Separating the secret from the inheritance of his son, the deceased mother again fell in pain wildly. Zaynab's eye often went down to the scallops, when he was drinking tea... In this case, the Uzbek oyim ate constipation, did not know the taste of the bite of the food, in short, the sitting was literally without salt and meaningless fur"[2, 126-127].

Above, Uzbek oyim, who began to understand the tragedy that followed his work, which he was doing without any effort to prevent, was portrayed as an artist in his own oil, in which he was embarrassed by the situation in which he was being fried, and in which he was doing false things to each other. "Each episode of Abdulla Qadiri's miraculous pen serves the content and essence of the work, the interpretation of the characters, as well as the fulfillment of a certain ideological, artistic and aesthetic task"[3,68].

The writer consistently interprets during the events of the novel that the mutual disputes between the khanates, as well as the killing of innocent people as a result of this, the atrocities in the country eventually led to the invasion of Turkistan by Tsarist Russia. Through the terrible image of the heads taken during the siege of Tashkent, the main ideological paphos of the work is expressed in a peculiar way: "three to four hundred people are a top, fixed from the head. Long beards that come to the crow, the head of the got sparse hair, roaring faces, the groin beeps, the place of the brunette without half-open cowards a whiteness crow eyes darken to the world and the same life as the curse. Especially one head, probably not even twenty years have passed, has not



yet come out. The diet darkens as if looking for someone with half-open eyes between the dark eyebrows... Although the white teeth within the semi-open irises bite the tongue, the fur is "regret" readable "for being born in the same blind people in the same marriage[2, 64]. This image also shows that the writer is well aware of the "Boburnoma" and is affected by it. Also, the writer hid in the text of the above image that the basic situation of the people, which was an audience to the sad situation of Turkistan, which became a colony of the shuro government after Tsarist Russia, influenced by its ideology, was still going on.

As professor Umarali Normatov correctly pointed out, "Utgan kunlar" stand alongside rare examples of world realistic literature in terms of the subtle, skilful artistic research and analysis of mystery-magic puzzles" [4, 120].

Well, in the novel "Utgan kunlar", the hero and personages constantly manifest their national identity in terms of appearance and saja. In particular, the writer provides for the uniqueness of the appearance and character of the heroes through vital, live paintings. On the eve of the Tsarist Russia invasion, the Turkestan landscape, the customs of people, the lifestyle, the social life, the method of administration that is turning to decline, the reader is brought to the management environment. There is no doubt that the work enriches the spirituality of many generations, while the treasure trove of meaning, full of enchantments

REFERENCES

1. *Жаҳон адиблари адабиёт ҳақида (Озод Шарафиддинов таржималари) – Тошкент: Маънавият, 2010.*
2. *Абдулла Қодирӣ. Танланган асарлар. – Тошкент: "Шарқ", 2018.*
3. *Сабирдинов А. Маънавият ва маърифат чашмалари. –Тошкент: "Академнashr", 2016.*
4. *Норматов У. Қодирӣ мўъжизаси. – Тошкент: "Ўзбекистон", 2010.*



NUTRIENT INFLUENCE IN SOIL ENVIRONMENTS IN COTTON

Nazarov Mamadali

Candidate of Agricultural Sciences, Associate Professor

Akhmedova Dilfuza

Candidate of Biological Sciences, Associate Professor

Yunusov Mirzakarim

Candidate of Biological Sciences, Associate Professor, Ferghana State University

ABSTRACT

The experiments carried out to clarify the different norms of nitrogen, phosphorus and potassium in stationary experiments revealed the need to introduce nitrogen up to 3 times more than without nitrogen, the growth, development and metabolism in the root system of cotton is significantly accelerated.

KEYWORDS: Nutrients, nitrogen doses, nitrogen effects, soil alkalinity, root system, metabolism, synergism, antagonism.

INTRODUCTION

The assimilation of nutrients depends on the nature of their interaction: synergism manifests itself in strengthening, and antagonism in inhibiting the influence of one or of the elements when they are introduced in a complex.

An example of synergy is the positive effect of increasing doses and assimilation of

nitrogen on the removal of other nutrients, which has been established in different environmental conditions and in different crops. This effect of nitrogen is explained by an increase in the metabolic activity of plants, which is accompanied by an acceleration of the reaction and a change in the absorption capacity.

Table 1

Dynamics of assimilation of nutrients in cotton depending on increasing doses of nitrogen.

Timing of taking plant samples	Nitrogen doses	Assimilation of nutrients,%				
		N	P	K	Ca	Mg
10 may	N1	100	20,2	106,4	57,7	7,5
	N2	100	17,8	99,7	50,0	6,4
	N3	100	17,0	94,5	53,0	7,4
28 may (flowering)	N1	100	19,8	93,4	75,0	9,7
	N2	100	19,5	105,4	75,8	10,3
	N3	100	22,8	109,2	83,6	11,5
5 july (maturation)	N1	100	30,5	87,5	103,0	11,2
	N2	100	31,7	101,2	113,2	11,3
	N3	100	35,4	96,1	119,0	12,2

This conclusion is supported by factors, the assimilation of other elements begins to increase only after a certain time has passed since the active absorption of nitrogen (Table 1).

A consequence of the antagonistic relationship in the absorption of nutrients is a weakening of the relative absorption of sodium, magnesium and calcium as a result of an excessive



intake of potassium or less active absorption of sulfur and phosphorus with an excess of chlorine.

An antagonistic relationship is manifested by leaves between ions of the same type. Cations or anions, and they are more pronounced for cations, including hydrogen (H⁺). Its influence is manifested strongly with an increase in soil alkalinity, which is possible in colossi to some extent, with a large influence of pH on the assimilation of nutrients.

The experiments carried out under the conditions of a stationary experiment on a typical gray-earth soil with the addition of ammonia nitrogen, the coefficient of nitrogen utilization increased to 70-85 days. The growth of cotton, then declined slightly. The maximum nitrogen consumption was at a nitrogen dose of 120 kg / ha (75%), with an increase to 480 kg / ha (up to 85%).

However, at the time of harvesting, the nitrogen utilization rate under the option (20 is higher than 66%), of the applied amount than in the option 480 kg (52%). These data indicate the high assimilability of cotton root systems in relation to fertilizer nitrogen. In addition, it will be methodologically correct if we evaluate the coefficient of nitrogen utilization at the moment of maximum accumulation of the vegetative mass of the plant. The root system of cotton is characterized by an insignificant accumulation of nitrogen fertilizer.

Independently, nitrogen fertilization accumulated in the roots did not exceed 2-5% of the accumulated nitrogen in plants. In addition, the roots of the cotton plant remain in the soil and the old ones decompose, releasing bound nitrogen.

In the process of plant growth, nitrogen is absorbed not only from fertilizers, but also directly from soil nitrogen, therefore their ratio in the plant organism is constantly changing. At a low level of nitrogen nutrition (it was equal to 4 mg ha 100 g or 40 mg ha 1 kg of soil), the amount of nitrogen fertilizer (in% of the total accumulation of nitrogen in the plant) at the beginning of the growing season prevailed over the amount of soil nitrogen, as the plant ages, the proportion of the latter increased, while the proportion of nitrogen in fertilizers decreased.

Thus, by the 70-75th day of the growing season, their ratio was approximately equal. With a high level of nitrogen nutrition (16 mg per 100 g of soil or 160 mg / kg), the proportion of nitrogen fertilization decreased, and the proportion of soil nitrogen increased during the growing season of the plant.

However, under these nutritional conditions, the proportion of soil nitrogen was lower than with a low level of nitrogen nutrition. Therefore, during the growing season, the amount of nitrogen

fertilization largely prevailed over the amount of soil nitrogen.

So, the nature of the input of nitrogen fertilizer introduced into plants depends on the dose of nitrogen; when it is increased up to 4 times, the input does not decrease its use by the roots until the beginning of maturation of the boxes.

It is not yet clear to us what proportion of the applied nitrogen fertilizer is transformed in the soil and in plants.

Nitrogen fertilizers, getting into the soil, undergo a number of transformations, which are determined by both the levels of nitrogen salts and the level and ratio of other nutrients in fertilizers.

Some researchers believe that the expansion of the applied nitrogen fertilizers is determined by the level of ammonium and potassium in the fertilizers (Yarovenko, Korenkov et al. 1975, Pirokhunov, 1976, etc.). In addition, the applied nitrogen fertilizers undergo various biological, physicochemical transformations, as a result of which the plants do not use nitrogen fertilizers completely under irrigation conditions, some of them are washed out of the soil by water drains.

A high dose of ammoniacal nitrogen promotes growth immobilized by microflora, quantitative and qualitative changes in nitrogen introduced into the soil are determined by the form and doses of fertilizers, as well as soil properties (Mukhamedzhanov. Sulaimanov, Yarovenko 1975, etc.), therefore, maintaining the optimal level of nitrogen nutrition for plants is possible only taking into account environmental factors that determine the conversion of nitrogen fertilizers and soil.

Nitrogen introduced into the soil in early doses in the form of ammonium nitrate is distributed according to the forms as follows: by the time of sowing, fertilizer nitrates accounted for an average of about 50% of the applied amount of nitrogen, which was close to the applied amount of nitrates.

Ammonic nitrogen of fertilizers is found in an exchangeable and non-exchangeable state. However, if the share of exchangeable ammonium in the total amount of applied nitrogen decreased with increasing fertilizer dose, then the share of fixed ammonium increased.

The actual increase in the total mineral nitrogen from fertilizers turned out to be close to the applied amount; with an increase in the nitrogen dose, the composition and ratio of nitrogenous compounds changed significantly. With an increase in the dose of fertilizers, the proportion of nitrate nitrogen in the soil also increased. These changes were significant. If, in the PK variant, nitrate nitrogen was only 5% of the total

**Table 2****The ratio of forms of mineral nitrogen in the soil, % of the total amount by development phases.**

Option experience	Sowing 11.04			Budding, 16 06.			Flowering. 15.08		
	N-NO ₃ ⁻	N-NH ₄ ⁺ exch.	N-NH ₄ ⁺ Fix.	N-NO ₃ ⁻	N-NH ₄ ⁺ exch	N-NH ₄ ⁺ Fix.	N-NO ₃ ⁻	N-NH ₄ ⁺ exch	N-NH ₄ ⁺ fix.
1.PK (background)	5	2	93	3	2	95	6	2	92
2.PK+N1	9	4	87	3	3	94	6	2	92
3.PK+N2	13	6	81	5	4	91	8	3	89
4.PK+N4	18	9	73	10	4	86	9	3	88
5.PK+N8	24	10	66	12	3	85	9	3	88
6.PK+N16	29	15	56	23	8	69	7	5	88
7.PK+N32	40	10	50	35	7	58	25	7	68

As can be seen from these tables, nitrogen consumption during the growing season largely depends on the content of its mineral forms in the soil.

As the determination of the difference between the nitrogen content at the time of sowing and its content according to the phases of plant development showed, it can be seen that according to the first two doses (1 and 2 mg / 100 g of soil), the plants accumulated the bulk of nitrogen in the budding phase.

The difference in the removal of this element during the flowering phase for this variant was insignificant. The loss of mineral nitrogen in the soil is much greater than its consumption by plants.

However, during the flowering phase in variants with N4 and N8, the nitrogen removal coincided with the introduced decrease in mineral nitrogen in the soil.

At the N3 dose, a higher nitrogen removal by plants by the flowering phase was noted than its decrease in the soil.

Table 3**Nitrogen carryover depending on the level of nitrogen fertilization. mg plants**

Experience Option	budding	flowering
1.PK (background)	84	63
2.PK+N1	102	106
3.PK+N2	132	182
4.PK+N4	183	530
5.PK+N8	416	881
6.PK+N16	379	889
7.PK+N32	378	736

The loss of mineral nitrogen in the soil is due to a number of reasons: the consumption of nitrogen by plants, microorganisms, fungi, leaching of nitrates into deeper soil horizons and volatilization into gaseous compounds. The highest utilization rate of nitrogen from soil was observed in a rather narrow interval, which is the optimal use of nitrogen in fertilizers and soil. The maximum yield was obtained with N3, however, the nitrogen consumption for the formation of a unit of dry matter was not higher than that of lower doses of nitrogen.

During the growing season, transformation, migration and assimilation of nitrogen in the fertilizer and in the soil took place. Introduced nitrogen into deeper soil layers led to the accumulation of fertilizer nitrogen at depths of 100-

130 cm, which indicates part of the nitrogen migrates outside the root layer.

Consequently, with a relative deficiency of any substance for the formation of the crop, the plant uses the remaining substances to a lesser extent.

With the introduction of nitrogen in the late phases of plant development, when the growth processes are largely completed, it is less used in these processes and more in the synthesis of protein and its deposition in the reserve. Therefore, late feeding does not give a large increase in grain yield, but increases the protein content in it up to 1.5 times or more (Belousov 1975).

According to M. Nazarov (1990), nitrogen fertilization, in addition to increasing the protein



content, reduces lodging of cotton and increases plant resistance to wilts.

In the process of plant growth, nitrogen is absorbed not only from fertilizers, but also directly nitrogen from the soil, to which their ratio in the plant organism is constantly changing.

According to Belousov (1975), with a high level of nitrogen nutrition (16 mg N per 100 g of soil), the proportion of nitrogen in fertilizers decreased, and the proportion of soil nitrogen increased during the growing season. The accumulation of nitrogen in a plant is determined by the nature of the input of nitrogen in fertilizers and nitrogen in the soil. The intensity of nitrogen intake in cotton increased up to 50-60 days after the emergence of seedlings, and then slightly decreased by the time of seed ripening. Changes in the rate of intake of nutrients and their metabolism in a plant are closely related to its growth and development (Kursanov, 1976). At a low level of nitrogen nutrition, the dependence curve reaches a plateau at 20 mg N₁₅ per day, while at a high level of nitrogen, the curve forms a plateau at 115-120 mg N₁₅ per day. Under these conditions, up to about 100 mg / day, the dependence is directly proportional.

Therefore, at a rate of N₄ compared to N₁₂₀ mg / kg of soil, the synthesis of soil nitrogen slows down 3 times.

During the flowering period, with an increased level of nitrogen nutrition, an intensive synthesis of proteins in flowers is noted, and in the leaves it decreases markedly. With an increase in phosphorus levels, the intensity of protein synthesis in leaves, buds and flowers decreases.

Thus, the nature of the input of nitrogen from fertilizer into the plant was determined by its level in the soil, the rate of input, the characteristics of the growth and metabolism of nitrogen compounds during the growing season.

REFERENCES

1. Mukhamadzhonov M.V., Suleimanov S. *Scientific bases of plant placement in crops. Tashkent. 1975*
2. Yarovenko G.I. *Nitrogen nutrition of cotton. Tashkent. 1970*
3. Belousov M.A. *Physiology of the cotton root system. Tashkent. 1975*
4. Nazarov M. *Go'zaning oziqlanishi va hosildorlik. Toshkent. 1990*
5. Kursanov A.A. *Transport of assimilants to plants. Moscow. Science 1976*



THE HISTORY OF THE STUDY OF FOLLOW-UP SENTENCES IN COMPOUND SENTENCES

Teshaboev Dilmurod Rahmadjonovich

*Senior Lecturer, Doctor of philosophy in philology (PhD), Fergana State University,
City of Fergana, Uzbekistan*

ANNOTATION

This article focuses on the research on the joint sentence and its structural features, the history of their study, the formal and meaningful characteristics of the joint sentence with the follow sentence, the means of forming the joint sentence and their semantics, the link pieces, the following joint sentence, the central section.

KEY WORDS: *joint sentence, followed-up joint sentence, central section, one-member sentences, two-member sentences, fragmented sentences, fragmented sentences, link pieces, head predicative unit, follow-up predicative unit, grammatic formation of link pieces.*

INTRODUCTION

A compound sentence, which is a syntactic integrity, distinguished by its structural-semantic, intonational signs as a separate integral of the syntax, by the breadth of its meaning, from simple predicative units, is the supreme unit of the syntactic level of the language.

The subject of a joint sentence is one of the problems that has been attracting the attention of Uzbek linguists for many years. It should be noted that this topic is one of the widely studied areas of linguistics, but still it can not be said that the problems with this topic are completely solved.

The importance of research devoted to the joint sentence and its structural properties on syntax, created in traditional linguistics, is incomparable. The scientifically-based ideas in these works provide a solid basis for the emergence of new views on the nature of a joint sentence and its meaningful and structural features in today's linguistics.

The first stage of the study of joint theories of speech in Uzbek language, in general, in Turkish science, was created in the form of joint theories of speech, formed mainly in Russian linguistics [15]. Of course, the method of comparison in the correct interpretation of the natural essence of each phenomenon is of great importance. In this way, the expediency of use in showing the national originality of any language phenomenon is known to many.

It is known that even in the history of world linguistics, in particular, ancient Latin linguistics was formed on the basis of copying from Greek linguistics. Such a method does not allow to correctly and objectively understand the peculiarities of

language phenomena. The point is that linguistics, like other sciences, using the method of obtaining a template, other linguists must use the achievements creatively.

The classification of follow-up sentences in the Uzbek language is similar or closely related to the classification of follow-up sentences in other languages, and "types of follow-up sentences in Turkic languages, as well as in other languages, are inextricably linked with the theory of simple sentences" [5]. It has a very long tradition to correlate the following sentences with certain fragments of simple sentences [13, 19]. For example, in Spanish linguistics, the function of follow sentences is equated with the function of the word categories in simple sentences [10].

V.A.Beloshapkova noted that F.I.Buslaev the classification widely used in Russian linguistics in the middle of the XIX century. The classification is based on the similarity of follow-up sentences with simple sentences, and follow-up sentences with simple sentences. According to this classification has, cross-section, handle, complement and circumstance defined types of articulated sentences that follow. Position, style, degree-quantity, moment, cause, goal, condition and unhindered follow sentences are separated as appearances of follow sentences.

N.S.Pospelov's study plays an important role in the creation of a formative-meaningful classification in the issue of the classification of follow-up sentences. He divided the follow-up sentences into single-member and two-member types. N.S.Pospelov explains the difference between one member and two member sentences by the different



nature of the connection between the head and the following sentences. In single-member sentences, the follow-predicate unit determines a fraction in the head-predicate unit, that is, the follow-predicate unit refers to a word in the head-predicate unit. In two-member sentences, the follow sentence connects integrity with the uppermost clause [9]. V.A.Beloshapkova calls single-member and two-member sentences "fragmented" and "nofragmented". V.A.Beloshapkova and N.S.Pospelov's views on the issue of follow-up sentences, there is almost no difference.

In Turkish science, too, it is common that N.S.Pospelov's views, that is, the follow, relate to the fact that the predicative units can fully interpret the prime predicate unit or determine its part. For example, according to M.A.Askarova the content and the structure of the follow-up predicative unit differs from the head predicative unit and emphasizes that the head predicative unit interprets a part or the head predicative unit as a whole [22]. Based on the above classification, A.Z.Abdullaev and A.G.Javadov recommends dividing the following phraseological units in the Azerbaijan language into two meaningful-syntactic groups. They argue that the follow-sentence conjugative units, which interpret a division in the prime predicate unit, have one meaningful core, while the follow-sentence conjugative units, which interpret the prime predicate unit as a whole, have two meaningful nuclei [2].

M.I.Cheremisina and T.A.Kolosovas cannot deny that the functions of the components of the follow-sentence joint sentence and the sentence fragments are mutually similar. In their opinion, the possessive, the fractional, the complement, the predicate, the functions of the case in a simple sentence, the word form, through the word combinations, itches to the surface. When these functions are performed through predicative units, it becomes a joint sentence [23].

Any sentence in the language is a phrase from a certain system of syntactic places. Syntactic positions in simple sentences and compound sentences do not differ from each other, on the contrary, they form a commonality in this aspect [20]. I.N.Egorova also bases the presence of functional compatibility between simple sentences and follow-up sentences with the fact that the syntactic place is given by a sentence fragment or a predicative unit [12].

In ensuring the essence and application of the following sentence, the meaning and valence of the word in the task of the cross-section of the main sentence are considered important [11]. The syntactic place arising from the valence of the predicate can sometimes be occupied even by the subordinate predicative unit, due to the meaningful possibility of the predicate. On the contrary, if the syntactic place

is not occupied by the subordinate predicate unit, the following sentence does not find a compound sentence. Therefore, some linguists use the theory of valence in determining the composition of a follow-sentence compound sentence [17]. It is also worthwhile to sometimes turn to the theory of valence in the study of the semantic aspects of a subordinate clause.

Based on the above points, it can be said that it is more acceptable to classify the following sentence sentences by taking a template from the tasks of the fragments in simple sentences. Because, when the syntactic system of places is taken from the point of view, the following sentence-joint sentences are practically not distinguished from simple sentences. The grammatic basis of the sentence is the uppermost sentence in the follow-up sentence joint sentences. The following sentence is a sentence that interprets a particular section of the sentence structure [16].

In ensuring the essence and application of the predicative unit of the pronoun, the meaning and valence of the word in the task of the intersection of the main predicative unit are considered important. The syntactic role arising from the valence of the predicate can sometimes be occupied even by the subordinate predicative unit, proceeding from the meaningful possibility of the predicate. On the contrary, if the syntactic place is not occupied by the subordinate predicative unit, the following sentence predicative unit does not find content. Therefore, some linguists use the theory of valence in determining the composition of the phraseological unit with the pronoun follow. It is also worthwhile to sometimes turn to the theory of valence in the study of the semantic aspects of phraseological units with a follow sentence.

Based on the above points, we can say that it is more acceptable to classify phraseological units with a follow-up sentence, taking a template from the tasks of the parts in simple sentences. Because, when the system of syntactic places is taken from the point of view, the following phraseological phraseological units are not distinguished from simple sentences, almost, by the way. The grammatic basis of the sentence is the chief predicative unit in the predicative units of the follow-up sentence. The follow-up predicate is a sentence that interprets a particular part of the composition of the chief predicate unit [16].

In 50-60 years of the last century, serious attention was paid to the study of Uzbek language syntax. Sentences, which are considered a syntactic unit, formed as a result of a predicate connection are divided into simple and joint sentences according to the quantitative designation of the "predicate connection".



The study of joint sentences in Uzbek linguistics was initially conducted by H.Gaziev, M.Askarova, G.Abdurahmonovs was studied by in 40-60 years [1, 3, 21]. Later N.Mahmudov, N.Turniyazov, R.Sayfullaeva continued by a joint statement study, M.Askarova, G.Abdurahmonov, A.Berdialievs special attention is paid and their scientific views [1, 3, 4, 5, 6, 7, 8, 22].

Research of joint sentences with syntactic integrity, which differs from simple predicative units philolog scientist A.Mamajonov it was also studied. In his monograph entitled "joint sentence stylistics", the scientist views on joint sentences with follow-up sentences, the reference also refers to joint sentences with follow-up sentences, which are formed by fragments [14].

As in other linguistics, discussions on the following sentences in Uzbek linguistics have been going on for a long time.

In the classification of prepositional units with a follow sentence, it is necessary to pay attention not only to the following predicative unit, but also to the prime predicative unit. In this respect, the prime predicate units are also divided into two types: 1) prime sentences without reference parts, 2) prime sentences with reference parts [16, 18].

Conclusion.

In conclusion, we can say that in Uzbek linguistics it has become customary to interpret the predicative unit subordinate to the prime predicative unit in the phraseological units by the term "follow sentence" and is absorbed. Taking these into account, we also found it desirable to study in this article the unit that is subject to the prime predicative unit with the term "follow predicative unit" [18].

In general, the problems associated with the study of conjugative units are quite a few. These issues are among the problems facing the Uzbek language syntax today and require thorough and thorough study.

REFERENCES

1. Абдурахмонов Ф.А. Қўшма гап синтаксиси асослари. Тошкент, 1958.
2. Абдуллаев А.З., Джавадов А.Г. О семантическом ядре азербайджанского сложноподчиненного предложения. Советская тюркология, 1987, № 1, С. 52
3. Асқарова М. Ҳозирги замон ўзбек тили ва қўшма гаплар. Тошкент, 1960.
4. Асқарова М.А. Способы подчинения и типы придаточных предложений в современном узбекском языке. АДД. Ташкент, 1963.
5. Баскаков А.Н. Предложение в современном турецком языке. М.: Наука, 1984, С.119.
6. Бердиалиев А. Эргаи гапли қўшма гап конструкцияларида семантик-сигнификатив парадигматика. Тошкент: Фан, 1989.
7. Бердиалиев А. Семантико-сигнификативная парадигматика и синтагматические отношения в конструкциях сложноподчиненного предложения узбекского литературного языка. АДД. Ташкент, 1989.
8. Бердиалиев А. Ўзбек тилида омоним модели эргаи гапли қўшма гаплар. Тошкент: Фан, 1990.
9. Белошапкова В.А. Современный русский язык. Синтаксис. М.: Высшая школа, 1977, С. 216-219.
10. Васильева-Шведе О.К., Степанов Г.В. Теоретическая грамматика испанского языка. Синтаксис предложения. М.: Высшая школа, 1981, С.232.
11. Гаврилов Г.Ф. Об изоморфизме сложно-подчиненного предложения и словосочетания. – В кн.: Подчинение в полипредикативных конструкциях. Новосибирск: Наука, 1980, С. 29.
12. Егорова И.Н. Позиционные эквиваленты слова в составе предложения. – В кн.: Русский язык. Грамматические исследования. М.: Наука, 1967, С. 78.
13. Корнилов В.А. К проблеме изоморфизма сложно-подчиненного предложения и подчинительного словосочетания. – В кн.: Подчинение в полипредикативных конструкциях. Новосибирск: Наука, 1980, С. 13.
14. Мамажонов А. Қўшма гап стилистикаси. Тошкент. 1990. 110 б.
15. Маҳмудов Н.М. Қайта қуриш ва ўзбек морфологиясининг айрим масалалари. Ўзбек тили ва адабиёти. 1988. 3-сон, 16-20-бетлар.
16. Нурмонов А., Маҳмудов Н., Аҳмедов А., Солиҳўжаев С. Ўзбек тилининг мазмуний синтаксиси. Тошкент: Фан. 240-б.
17. Страхова В.С. Некоторые лингвистические основы обучения гипотаксису. – В кн.: Проблемы ученика русского языка как иностранного. Синтаксис. М.: Русский язык, 1980, С. 456-457.
18. Тешабоев Д. Ўзбек тилидаги ҳавола бўлакчи синтактик конструкциялар: Филол. ф.ф.док. (Phd) дисс. автореф. – Фаргона, 2019.
19. Цеулин В.В. О классификации сложноподчиненных предложений. Воронеж: Изд-во Воронежского университета, 1972, С. 3-12.
20. Шутова С.И. Вопросы теории синтаксиса, М.: Наука, 1984, С.55
21. Ҳозиев Ҳ. Ҳозирги замон ўзбек адабий тилидаги қўшма гапларнинг состави ҳақида / / Ўзбек тили илмий грамматикасидан материаллар. Тошкент, 1941. 127-156 бетлар.
22. Ғуломов А., Асқарова М. Ҳозирги ўзбек адабий тили. Синтаксис. 3-нашири, Тошкент: Ўқитувчи, 1987, 187-бет.
23. Черемисина М.И., Колосова Т.А. Очерки по теории сложного предложения. Новосибирск: Наука, 187, С. 61.



THE PROCESSES OF DEVELOPMENT AND MOTIVATION OF PROFESSIONAL COMPETENCE OF FUTURE PEDAGOGICAL EDUCATORS ON THE BASIS OF REFLEXIVE MONITORING

Hamraeva Aziza Farhadovna
Teacher, Jizzakh State pedagogical Institute

ANNOTATION

In today's globalized world, the quality of professional and pedagogical training of future pedagogical teachers is radically renewed, modernized, directly connected with its content.

KEY WORDS: *development, motivation, competence, pedagogical educators, reflexive monitoring.*

DISCUSSION

To significantly improve the quality of training of pedagogical personnel, it is necessary to ensure the synthesis of pedagogical and technical knowledge. The professional formation of pedagogical teachers the integration of pedagogical and technical knowledge based on changes in the fields of Science, Education, Technology, Innovation and production economy serves to ensure the effectiveness of the educational process. This process provokes the need to make certain changes in the creation of the technology of justification and formation of professional competence of the pedagogical teacher training content. A number of scientific works have been devoted to the study of the problem of formation of professional competence of the future pedagogical teacher, dissertations have been written, studies have been conducted. However, the interest of scientists to various aspects and aspects of this problem is not diminished at all, but it is a testimony of the special importance and relevance of modernization and development of the educational system in the global age.

The main purpose of formation of specialist competence is determined by the formation of pedagogical conditions necessary for formation of professional competence of future pedagogical teachers, creation of the necessary pedagogical conditions for ensuring their professional and personal perfection in higher educational institutions, modernization of the content and structure of training of young teachers, determination of psychological and pedagogical conditions and development of important factor in improving the educational process is inextricably linked with the formation of a high

level of professional competence of pedagogical teachers in the system of higher education. Therefore, with the effective use of information and communication technologies, it is possible to create theoretical and practical bases of the process of formation of professional competence of pedagogical teachers by connecting them with educational technologies and using textbooks, monographs, educational methodological complexes and scientific articles efficiently.

By improving and developing the processes of development of their professional competency on the basis of studying the needs and opportunities of teachers in creating the necessary conditions for the formation of an educational environment oriented to the training of competitive, highly qualified specialists in pedagogues, it is also possible to promote the process of motivation in them.

Motivation in the process of development of professional competence in teachers it is possible to form positive motivations that cause interest to teachers in the creation of effective ways to develop their professional competence, work on themselves in teachers, increase their knowledge, learn innovative technologies and improve their continuous qualification.

In the processes of development of professional skills in teachers, motivations are of particular importance, since the development of professional competency in them depends on the effectiveness of the educational process and educational relations processes, the effectiveness of these processes represents the fruitfulness of the processes of development of professional competency. In such a case, it can be said that the



study of professional competency developmenttirishga influencing motivations in teachers is of particular importance and such motivations can also be called professional competency development motivations.

Teachers of pedagogy in the conditions of globygan, information and communication technologies are entering into each sphere, the world is becoming more digital and "updated Uzbekistan" are also required to identify the motivations that motivate the study of reforms, strategies of action, the possibilities of the law on education, scientific and technical achievements, innovative methods and technologies of organization and management of pedagogical processes and Because the specific characteristics of professional competency development motivations have their impact on the effectiveness of professional competency development processes and educational relationship processes, which means that different motivations lead to changes in the educational environment in which professional competency developmenttirishga is directed.

It is known that motivation is an integral part of human life in a broad sense, it is a complex, multifaceted Superintendent. As a result of the increase in the number of teachers over the years, the activities of the teachers can be managed with the help of various motivations. With the help of these motivations, the effect of willful behavior on the body and the muvo-fixing of activities is effective, the effectiveness of the results of activities will depend on the nature of the motivations, which in turn will represent the effectiveness of the motivation process.

Motivation in the process of development of professional competence in teachers is a multi-level and complex system of motivating teachers to study national values, national traditions, reforms carried out in our country and their results, achievements of Science and technology, needs, interests, aspirations, means, goals, desires, interests, requirements, values, customs and others are the components of this system. An important role in motivation is also played by pedagogical skill, pedagogical etiquette, morality, personality intelligence and erudition.

In the professional knowledge of the teacher, it is very necessary to establish a subordinate relationship with the student, to be able to consistently comprehend the essence of pedagogical processes, pedagogical realities, to learn the basics of World pedagogical culture and national pedagogical experience, to apply them to their activities on the basis of integration, to be constantly aware of innovative innovations, to generalize

On the basis of pedagogical knowledge, again, the pedagogical reflection (lot."reflexio" - back,

reflection) is also noticeable. Sources cite the concept of "reflection" the qualities inherent in a person's own knowledgeable educator:

- interaction with social subjects, cultural interaction;

- to be able to find, process and use information in the direction of specialization, based on the content of education, in the process of processing and professional activity;

- pedagogical knowledge of the delivery of educational information to students;

- the ability of the educator to organize professional activities in accordance with the existing social requirements, legal norms and standards, a special activity of knowledge of professional training, is interpreted as "awareness through thinking of the essence of personal experiences, feelings and fantasies". In pedagogical activity, his manners also play an important role. Moreover, pedagogical etiquette is one of the important requirements and factors that ensure the success of educational and educational processes. These requirements are an important factor driving the process of pedagogical work, which is organized by the pedagogue. The system of pedagogical etiquette is of particular importance for the professional duty of the educator, for the fulfillment of moral obligations before the society, the pedagogical community and the student.

The system of pedagogical etiquette requirements the requirements for a specific pedagogical etiquette in the discharge of professional duty by the teacher, the fulfillment of moral obligations before the society, the pedagogical community and the student are the tasks that must be carried out in the process of pedagogical labor, activities organized by the teacher.

In conclusion, it should be noted that motivation in the processes of development of professional competency in teachers is very important, since it is necessary to create conditions in educational institutions not only for training in the courses of professional development, but also for independent education, in which the control and coordination of the process of independent education of teachers is of particular

Motivation gives impetus to the behavior of teachers in the direction of the development of their professional competence, determines the goals that need to be achieved. Motivation is a dynamic process that leads to action in the direction of development and improvement of collaborative activities of participants in the educational process.

In the process of motivation, it is necessary to take into account the needs that characterize the needs of the teachers or their general interests, since motivation is based on the satisfaction of the needs.



Hence, the needs are the motivations that guide the development of professional competency in teacherstirishga service-intensive activities, that is, learning, working on their own and acquiring knowledge, and the development of professional competency in pedagogical teacherstirishga in addition to the loss of service, it also encourages them to struggle for physical, mental, labor, as well as for recreation, knowledge acquisition, skill learning.

REFERENCES

1. Муслимов Н.А. Формирование профессиональной компетенции будущих педагогов основе применения информационных и педагогических технологий. Россия. Молодой ученый. 2012 - г. - №1. 0,36 б.т. 62.
2. Маркова А.К. Психология профессионализма. - М.: Знание, 1996.-308 с.
3. Маркова А.С. Технология массового тестирования студентов: Учебное пособие. - М., 1996. 67. Матросова Н.Л. Деловая игра в подготовке учителя. — М., 1997.
4. Муслимов Н. Касб таълими ўқитувчилари амалий компетентлигини шакллантиришда ихтисослик фанларини ўрни. Педагогик таълим (илмий-назарий ва методик журнал) 2012 йил, 61-64 б.
5. Касбий маҳорат ва компетентлиликни ривожлантириши жараёнида мотивлаштириши – тема научной статьи по наукам об образовании читайте бесплатно текст научно-исследовательской работы в электронной библиотеке Кибер Ленинка (cyberleninka.ru)



A STUDY ON CUSTOMER'S SATISFACTION TOWARDS MAHINDRA BOLERO IN COIMBATORE

Dr. P.Dhanya

*Assistant Professor, Department of Commerce with Professional Accounting,
Dr. N.G.P. Arts and Science College, Coimbatore*

M .Kousalya

*(Reg. No: 171PA125), B.Com. (PA), Department of Commerce with Professional Accounting,
Dr.N.G.P Arts and Science College, Coimbatore*

ABSTRACT

The knowledge will assist the makes with receiving new methodologies which would help not exclusively to draw in new client yet in addition the keep up the devotion of the current client, as in the present serious situation the purchaser are set up to pick their correct item dependent on their necessities as well as However there is high development inclination for it faces a few challenges in accomplishing their objective. Thus the motivation behind this study is to distinguish the power that effect on customer shopping design especially in Coimbatore. It additionally on the essential of individual premium appeared by the produces on them The methods utilized in showcasing incorporate picking objective business sectors through market investigation and market division, just as understanding strategies for effect on the customer conduct. The advertising arranging makes systems for the organization to put publicizing to the devoted purchaser.

INTRODUCTION

Customer satisfaction (often abbreviated as CSAT, more correctly CSat) is a term frequently used in marketing. It is a measure of how products and services supplied by a company meet or surpass customer expectation. Customer satisfaction is defined as "the number of customers, or percentage of total customers, whose reported experience with a firm, its products, or its services (ratings) exceeds specified satisfaction goals.

"The marketing accountability standards board (MASB) endorses the definitions, purposes, and constructs of classes of measures that appear in marketing metrics as part of its ongoing common language in marketing project.

STATEMENT OF THE PROBLEM

The numbers of motor can users are increasing day by day in India. Companies make a aggressive

advertising, marketing and promotional efforts which compel other manufactures to focus on their marketing efforts as well. There are number of manufactures in market to manufacture the motor car in the desired quality for reasonable prize. All the manufactures of the motor industry try to satisfy the need of the customer. These companies resort to price reductions, new function additions, value additions and focus advertising and promotional campaigns.

Scope of study

- It this competitive world retaining the customers as become important part and parcel of business activities, since in their area the people who adapt to change and new technologists will survive.
- The study will help to understand customer need, preference and what they require from the service station and the study will not only



help me as automobile to improve its service standard.

Objective of study

- To identify the level of satisfaction of the customer.
- To evaluate the factors influencing to their satisfaction level.

To offer suggestion to improve the quality of bolero car.

STATISTICAL TOOL USED

1. Simple Percentage Analysis
2. Likert Scale Analysis

Limitation of study

The research is being carried out in Coimbatore city only from 150 respondents using an interview schedule method. However, data were collected from those respondents with utmost care and personal attention to avoid ambiguity in the results of the study.

REVIEW OF LITERATURE

Praveen Kumari and Satinder Kumar (2004) has made their study on “Consumer brand preference towards mobile phone: Effect of mobile phone attributes on purchase decision”

The mobile phones dominates most of modern human in every movement of life. This study investigates the consumer brand preference towards mobile phones by factors analysis method in this strategy. The entertainment attributes incorporates Bluetooth, MP 3 Player and playing games etc. Image with resource involves dual sim, Wi-Fi and brand image.

Matti Leppaniemi and Jaakko sinisalo and Heikki karjaluo (2006) have made “A review of mobile marketing research”. The purpose is to accomplish a purpose of comprehensive review a strong tradition in marketing research of reviewing existing research to understand better the research in the field, There is no commonly accepted classification for mobile marketing in several research under the research new different means of communication which

should be integrated into the marketing communications.

Roger Strom (2010) made “The value of mobile marketing for consumers and retailers”. The study identified different usage level segments of mobile pull advertising users. It revealed limited knowledge about mobile device shopping behavior. This also indicated that PC internet may be used for recruitment of mobile device on markets with high fixed internet penetration and fractions of dual media users. The revealed multiple support for mobile marketing increasing perceived value for consumers and outcome value for retailers. For internal, and by assumptions for in store mobile marketing, retailers also needed to consider computer self- efficacy, education, position experience and cognitive style of research marketing.

DATA ANALYSIS AND INTERPRETATION

The data collected from the samples have systematically applied and presented in the tables under various headings in the following pages. They were also arranged in such a way that, a detailed analysis can; be made so as to present suitable interpretation for the same. The data have been analyzed using the following statistical tools.

- Simple percentage analysis
- Likert scale analysis

SIMPLE PERCENTAGE ANALYSIS

The percentage analysis is mainly employed to find the distribution of different categories of respondents. As the value are expressed in percentage it facilities comparison and standardization. The analysis describes the classification of the respondents failing under each category.

TABLE 1
AWARENESS ON THE MAHINDRA BOLERO

Awareness	No. Of respondents	Percentage%
Through advertisement	38	32
Through posters	19	16
Through pamphlets	34	28
Through dealers	29	24
Total	120	100

Sources: primary data



INTERPRETATION

Out of the 120 respondents 32 % are known by through advertisement, 28 % are through pamphlets, 24 % are through dealers, and 16 % are through posters.

INFERENCE

The maximum respondents are known through advertisement.

**TABLE 4.2
PERIOD OF USAGE**

Period of usage	No. Of respondents	Percentage %
Past 1 year	33	28
Past 2 year	45	37
Past 3 year	26	22
Past 4 year	16	13
Total	120	100

Sources: primary data

INTERPRETATION

Out of the 100 % of respondents, 37 % are respondents was using in past 2 years, 28 % are respondents in past 1, 22% are respondents using in past 3 and 13 % are respondents using in past 4.

INFERENCE

Finally, maximum respondents was using in past 2 year.

LIKERT SCALE ANALYSIS

A Likert scale analysis is a method of meaning attitude. Ordinal scale of responses to a question or statement, ordered in hierarchical from strongly negative to strongly positive. Used mainly in behavioral science, in likert's method a person's attitude is measured by combining (adding pr averaging) their responses all items.

FORMULA

Likert scale = $\sum (FX)$ / Total number of respondents

F = Number of Respondents

X = Likert Scale Value

(FX) = Total Scale

**Table 3:**

S.NO	Factors	No.of respondents(f)	likert scale value(x)	Total (fx)
1.	Excellent	25	5	125
2.	Good	45	4	180
3.	Average	35	3	105
4.	Poor	10	2	20
5.	Very poor	5	1	5
	Total	120		435

Source: primary data

$$\begin{aligned} \text{Likert scale} &= (\text{fx}) / \text{total number of respondents} \\ &= 435 / 120 \\ &= 3.625 \end{aligned}$$

Likert scale value (3.625) is higher than a mid-value . so the respondents are satisfied with the availability of the bolero cars.

FINDING, SUGGESTION AND CONCLUSION

FINDINGS

- ❖ The majority 84% of respondents are male.
- ❖ The majority number of respondent fall between the age group above 25 years are 45%
- ❖ The majority out of 120 respondents are married
- ❖ The majority out of 100 respondent 72% respondents are business person
- ❖ The majority out of the 120 respondents 31% respondents are complete PG
- ❖ The majority out of 120 respondents 42% respondents earning 10000to 20000
- ❖ The majority of 34% respondents are using 10lakhs to 11lakhs valuable bolero
- ❖ The majority out of 120 respondents 86% are using power steering
- ❖ The majority respondents are satisfied in look with 37%
- ❖ The majority respondents suggests that space availability in Mahindra bolero spare with 34%
- ❖ The majority of 42% respondents are faced in highly cost maintenance
- ❖ The majority respondents are feel difficult with 69%
- ❖ The majority of 40% respondents are using in 2 bags
- ❖ The majority of 68%were like in features option.
- ❖ The majority respondents were attracting to purchase Mahindra bolero like brand name with 33%
- ❖ The majority respondents are like power steering with 40%in Mahindra bolero.

SUGGESTION

- ❖ Mahindra bolero is easy to handle and it obey all the control quickly
- ❖ Mahindra bolero is the medium level mileage van and it have lot of important factor like smooth engine power and suspense etc...
- ❖ More features should be added to the bolero according to the needs of the customer because their competitors coming with new models
- ❖ Company should setup center at dealers level itself they should train some personnel for exclusive maintenance

CONCLUSION

The Mahindra bolero was inferred that most customer of high income group preferred the supply of Mahindra bolero 2523cc most of the customer agree that bolero best quality with responsible price, more over the customer preferred the Mahindra bolero for the propose of more comfortable.

REFERENCE

1. Praveen Kumari and SatinderKumar (2004) has made their study on "Consumer brand preference towards mobile phone: Effect of mobile phone attributes on purchase decision, P.P.No: 1-10, ISSN No; 2278-487X, 2319-7668.
2. MattiLeppaniemi and JaakkoSinislo and HeikkiKarjaluo(2006),A review of mobile marketing research,volume-1,issue no:1, p.p.No:1-12.
3. Roger Strom (2010), The value of mobile marketing for consumer and retailers (2010), volume no-30, p.p.No:144-151.



PRIORITY ANALYSIS OF ROAD DEVELOPMENT IN REGIONAL DEVELOPMENT IN SOUTH LABUHANBATU REGENCY

Toni Zevelvey Silalahi¹

¹Department of Regional and Rural Development Planning, University of Sumatera Utara, North Sumatra, Indonesia

Rahim Matondang²

²Department of Regional and Rural Development Planning, University of Sumatera Utara, North Sumatra, Indonesia

Agus Purwoko³

³Department of Regional and Rural Development Planning, University of Sumatera Utara, North Sumatra, Indonesia

ABSTRACT

The study aimed to determine the implications of road development priorities for regional development in South Labuhanbatu Regency. Primary data were obtained from the results of a questionnaire given to 13 respondents (for the AHP method) and 35 respondents for the community in terms of regional development. Data collection methods were carried out through interviews, questionnaires, and documentation studies. Data analysis was performed using the Chi-square test. Based on the criteria of benefits, the main benefit obtained from the construction of these priority roads is the smooth transportation of goods and people. Based on input, information, data, and analysis results, it shows that the construction of priority roads has significant implications for regional development in South Labuhanbatu Regency.

KEYWORDS: *AHP, Road Development Priority, Regional Development*

1. INTRODUCTION

South Labuhanbatu Regency is a division of Labuhanbatu Regency by Law Number 22 Year 2008 dated June 24, 2008 concerning the Establishment of South Labuhanbatu Regency. As a new autonomous region, the South Labuhanbatu Regency Government must improve itself and implement a well-planned program which is contained in the Labuhanbatu Selatan District Medium-Term Development Plan (RPJMD) and the Regional Government Work Plan (RKPD) including road infrastructure development aimed at realizing prosperity people and improve people's lives.

The Regional Medium-Term Development Plan (RPJMD) of South Labuhanbatu Regency for 2016-2021 and the Regional Government Work Plan (RKPD) for South Labuhanbatu Regency for 2020 do

not contain priorities for road development in South Labuhanbatu Regency. The Regional Development Planning Document of South Labuhanbatu Regency only contains the long target of road development for South Labuhanbatu Regency that will be achieved. So that in the preparation of the Draft Regional Regulation on Regional Revenue and Expenditure Budget (Ranperda APBD) of South Labuhanbatu Regency, the Road Development Activities set forth are the aspirations of the community which have been agreed to be priorities from the Village, District, Regency level development planning deliberations (Musrenbang) and the main ideas of the Regional People's Representative Council (DPRD) which is different every year which causes no policy on the direction of road development for South Labuhanbatu Regency. This makes the construction of roads unfocused each year and always varies.



Table 1
Regency Road Condition Data based on Surface Type

Surface type				Total (km)
Concrete (km)	Asphalt (km)	Gravel (km)	Dirt	
52,874	269,401	451,502	210,524	984,301

Source: road database 2018, Ministry of Public Works and Housing (PUPR), South Labuhanbatu Regency

The limited funds of the South Labuhanbatu Regency Government in running the wheels of government and realizing the programs that have been planned and contained in the Regional Development Plan Documents of South Labuhanbatu Regency,

including the road infrastructure development program, are very slow. The budget data for road infrastructure development in the South Labuhanbatu Regency Government (T.A 2017 to T.A 2020) can be shown as follows:

Table 2
Road Infrastructure Development Budget

No.	Fiscal year	Budget Ceiling	Description
1.	2017	75.203.420.900,-	APBD and Regional Revenue and Expenditure Budget – Revised (APBD-P) 2017
2.	2018	84.714.167.600,-	APBD 2018
3.	2019	93.047.825.391,-	APBD and APBD-P 2019
4.	2020	78.070.260.700,-	APBD 2020

Source: PUPR Office of South Labuhanbatu Regency

Considering the length of roads that must be managed by the South Labuhanbatu Regency Government while the funds for road infrastructure development are very limited, it is necessary to prioritize road construction so that the allocated funds have an impact on the development of South Labuhanbatu Regency.

2. RESEARCH METHODOLOGY

The research method used in this research is descriptive analysis in determining the priority of road development in South Labuhanbatu Regency. In this study, respondents for the criteria of benefits came from several South Labuhanbatu regency government agencies that have links to transportation, road construction planning consultants, and community leaders. Researchers combine elements of government and society as respondents so that the information collected is accurate, balanced and to avoid leading to opinion when respondents only come from elements of government. In previous studies, researchers have never found road users as respondents for the benefit criteria.

The criteria used as respondents from the elements of the Regional Apparatus Organization of the South Labuhanbatu Regency Government are as follows: hold a position at echelon III level, have experience in occupying positions at echelon III level

for at least 2 (two) years, have a minimum education level of Bachelor (S-1), hold the last position for at least 1 (one) year.

Those who become consultant expert respondents hold a position as team leader (activity manager), have a minimum Bachelor's (S-1) level of education, have at least 5 (five years of experience as a road infrastructure planning or supervision expert, have worked at least 3 (three years in the South Labuhanbatu Regency as a road enforcement planning or supervision expert.

3. LITERATURE REVIEW

Economic development is a multidimensional process that involves major changes to both changes in the economic structure, social changes, reducing or eliminating poverty, reducing inequality and unemployment in the context of economic growth (Todaro, 2003).

According to Miraza (2006), one of the key issues that must be considered in regional planning is the issue of transportation. Kamaluddin (2003) notes that transport is an essential element and functions as the lifeblood and the development of economic, social, political, and demographic mobility that follows developments in various sectors.

According to Sandy (1992), regional development is the implementation of national



development in an area that is adjusted to the area's physical and social capabilities and complies with relevant laws and regulations. Meanwhile, regional development is an act of developing a region or developing an area to increase the quality of welfare of residents, or to promote and improve something that already exists, according to Hadjisaroso (1994) (Jayadinata, 1992).

The main objective of regional development is to harmonize the various sectoral and regional development activities so that the use of the space and services found therein will optimally promote the activities of community life within the context of the expected goals and objectives of regional development. Optimal implies that it can be achieved at a satisfactory level of prosperity and in line with the socio-cultural and sustainable aspects of the environment (Ernan, Sunsun and Diah, 2011).

To drive the wheels of economic development, the role of infrastructure as a locomotive for national and regional development is essential. In macroeconomic terms, the provision of infrastructure services influences the marginal productivity of private resources, while the availability of infrastructure services affects the decrease of the cost of production in the context of microeconomics. Thus, both in the production process and in promoting the sale of goods and exports, their position is very critical (Permana, 2011; 1).

Article 1(1) of Regulation No 03/PRT/M/2012 of the Minister of Public Works on the Guidelines for the Determination of Road Functions and Road Status specifies that a road is a land transport infrastructure covering all parts of the road, including complementary buildings and equipment designed for traffic, above ground level.

Article 4(1) of Government Regulation No 34 of 2006 on roads states that public road administrators are obliged to make efforts to ensure that roads can be used to optimize the welfare of the population, in particular, to improve national economic growth, by keeping the overall transportation costs as low as possible.

Roads can be classified as follows, under Government Regulation No 34 of 2006 concerning roads:

Based on the function and role

1. Primary arterial roads, roads that connect adjoining first-tier cities or connecting first-tier cities with second-tier cities.
2. Secondary or sub arterials, a road connecting the primary area to the first secondary area or the secondary area connecting the secondary area to the secondary area or the secondary area to the second secondary area.
3. Primary collector, the road that connects the second and third city levels.

4. Secondary collector, a road that connects between the second center level or between the second and third centers.
5. Primary local road, the road that connects the parcel with the city at all levels.
6. Secondary local road, a road connecting the settlement with all secondary areas.
7. Primary environmental road, roads that connect between activity centers in rural areas and roads within rural areas.
8. Secondary environmental road, menghubungkan antarpersil dalam kawasan perkotaan.

Based on its carrying capacity

1. Class I roads, arterial roads accessible to motor vehicles including their cargo with a width of not more than 2,500 mm, a length of 18,000 mm, and a heaviest axle load greater than 10 tonnes, or Average daily traffic > 20,000 pcu.
2. Class II roads, arterial roads that can be passed by vehicles with a width not exceeding 2,500 mm, a length of 18,000 mm, and the heaviest allowable axle load of 10 tons, or average daily traffic < 20,000 pcu.
3. Class III-A roads, arterial or collector roads that can be traversed by vehicles and their cargo with a size of not more than 2,500 mm, a length of 18,000 mm, and an allowable axle load of 8 tons.
4. Class III B roads, collector roads that can be traversed by vehicles with their cargo with a width of not more than 2,500 mm, a length of 12,000 and the heaviest allowable axle load of 8 tons.
5. Class III C roads, local roads that can be traversed by vehicles of their cargo with a width of not more than 2,100 mm, 9,000 mm length, the heaviest allowable axis is 8 tons

Based on the obstacles

1. Freeway, marked with an intersection of the type of intersection found on the freeway, has a long-distance on each side of the road so that the traffic flow can travel without the flow being cut off by the flow coming from the left and right sides of the road.
2. Highway, marked by intersection of a level. This road generally has obstacles in terms of shape and geometry. Roads in the form of crossing each other have warning signs that cause the current to slow down or even stop for a moment.

C. Based on the management

1. National road, roads built by the central government.
2. Provincial road, roads built by the provincial government
3. Regional/City road, roads built by the Local Government (Regency/City).
4. Village Road, a road built by the Village Government



4. RESULT

Overview of South Labuhanbatu Regency

Geographically, South Labuhanbatu Regency is located between the coordinates 10 26'00 " - 20 15 '55' North Latitude and 99 04' 00 " - 100 26'00 " East Longitude with an altitude of 0 to 500 meters above sea level, with an area of 3,116 km² (311,600 Ha), of the total area of South Labuhanbatu Regency of 162,549 Ha or around 52.17% are oil palm plantations which include: 121,628 Ha managed by plantation companies and around 40,921 Ha managed by smallholder plantations.

The boundary of the South Labuhanbatu Regency is to the north by Labuhanbatu Regency, to

the south, to the west by North Padang Lawas Regency, to the east by the Riau Province.

South Labuhanbatu Regency, like most other areas in the North Sumatra region, includes areas with tropical climates. This area has two seasons, the rainy season and the dry season. The dry season and the rainy season are shown by the number of rainy days and the volume of rainfall in the month the season occurs. During 2018, the average rainy day in South Labuhanbatu Regency was 14.17 days per month with an average rainfall of 220 mm.

South Labuhanbatu Regency consists of five sub-districts, with an area as follows:

Table 3
Sub-district area in South Labuhanbatu Regency

No.	Sub-district	Capital	Area (km ²)	Ratio to Regency Area (%)
1	Sungai Kanan	Langgapayung	484,35	15,54
2	Torgamba	Aek Batu	1.136,4	36,47
3	Kotapinang	Kotapinang	482,4	15,48
4	Silangkitang	Aek Goti	303,7	9,75
5	Kampung Rakyat	Tanjung Medan	709,15	22,76
Total			3.116	100,00

Source: South Labuhanbatu Regency in Figures, 2019

Road Network in South Labuhanbatu Regency

South Labuhanbatu Regency has 984,301 km of Regency roads with a total of 286 sections according to the Decree of the South Labuhanbatu Regent Number: 600/209 / DPU-LS / 2016 dated 17 November 2016 concerning the Stipulation of the Road Status of South Labuhanbatu Regency.

Based on the priority stages carried out, of the 286 road segments in South Labuhanbatu Regency, 8 (eight) selected roads were selected to be managed: (1) Padang Ri - Pantan - Aek Hije - Batu Ajo, (2)

Simaninggir - Asam Jawa, (3) Sp.Tolan - Tanjung Medan - Tanjung Mulia - Sidomulyo - Podorukun - Boundary of Riau Province, (4) Sp. Sungai Pinang - Tasik - Batu Ajo - Beringin Jaya, (5) Sp. Asam Jawa - Sumberjo -Pangarungan - Sp. Bunut - Batang Saponggol - Teluk Panji - Sidomulyo, (6) Sp. Sukajadi - Sapilpil - Sp. Teluk Rampah - Bangai - Sp. Limun - Rasau - Haramania - Gariang Sordang - Batu Ajo, (7) Cikampak - Bus II - Kp. Baru - Pinang Damai - Sp. Areca nut (8) Sp. Tugu Cikampak - Aek Raso - Torganda - HTI Sei Kebara - Cindur.



Table 4
Description of Priority Road for South Labuhanbatu Regency

No	Segment road	Road Condition			Type of surface
		Road Length (km)	Managed length (km)	Unmanaged length (km)	
1	Padang Ri - Pantan - Aek Hije - Batu Ajo	11,072	3,692	7,380	Concrete / asphalt / gravel / dirt
2	Simaninggir - Asam Jawa	7,700	0,370	7,330	Concrete / gravel / dirt
3	Sp.Tolan - Tanjung Medan - Tanjung Mulia - Sidomulyo - Podorukun - Batas Provinsi Riau	35,575	18,120	17,455	Concrete / asphalt / gravel
4	Sp. Sungai Pinang - Tasik - Batu Ajo - Beringin Jaya	21,265	4,892	16,373	Concrete / asphalt / gravel / dirt
5	Sp. Asam Jawa - Sumberjo - Pangarungan - Sp. Bunut - Batang Saponggol - Teluk Panji - Sidomulyo	43,183	21,076	22,107	Concrete / asphalt / gravel / dirt
6	Sp. Sukajadi - Sapilpil - Sp. Teluk Rampah - Bangai - Sp. Limun - Rasau - Haramania - Gariang Sordang - Batu Ajo	22,237	10,701	11,536	Concrete / gravel / dirt
7	Cikampak - Bis II - Kp. Baru - Pinang Damai - Sp. Pinang Awan	18,523	9,073	9,450	Concrete / asphalt / gravel
8	Sp. Tugu Cikampak - Aek Raso - Torganda - HTI Sei Kebara - Cindur	49,993	5,966	44,027	Concrete / asphalt / gravel
Total		209,548	73,890	135,658	

Source: Secondary Data Processing Results

Information is collected from each road section, which is a development priority, based on Table 4. 135,568 km is the length of the road which has not been built. The construction of these roads, as an industrial area for agriculture and oil palm, would increase agricultural economic activity in South Labuhanbatu Regency.

Implications of Road Priority Development in South Labuhanbatu Regency on Regional Development

Priority Road Development functions to increase economic activity and generate new

economic points from the areas connected by these road sections. The construction of these roads will have implications for regional development as seen from (1) Regional Potential Development (RPD), (2) Strengthening of Oil Palm Agriculture (PPKS), Strengthening Industrialization of Local Commodities (PIKL), and Smooth Transportation of Goods and People (KTBO). Based on the results of the questionnaire collected from respondents against these 4 (four) criteria (attachment 4) then tested using the Chi-Square test with the results as presented in Table 5.

Table 5
Respondent data to be performed Chi - Square test

Respondent Value	RPD (fo ₁)	PPKS (fo ₂)	PIKL (fo ₃)	KTBO (fo ₄)	Total
5	20	10	12	24	66
4	14	20	20	11	65
3	1	4	2	0	7
2	0	1	1	0	2
Total	35	35	35	35	140



From Table 5, the Chi-Square Test is carried out by looking for the value of f_n (expected frequency), f_o (observed frequency) which then obtained the value

of $f_o - f_n$, $(f_o - f_n)^2$ and the value of Chi quadrat (X^2) as in Table 6.

Tabel 6
Hasil Uji Chi - Square

f_{n1}	f_{n2}	f_{n3}	f_{n4}	$f_{o1} - f_{n1}$	$f_{o2} - f_{n2}$	$f_{o3} - f_{n3}$	$f_{o4} - f_{n4}$	$(f_{o1} - f_{n1})^2$	$(f_{o2} - f_{n2})^2$	$(f_{o3} - f_{n3})^2$	$(f_{o4} - f_{n4})^2$
16,5000	16,5000	16,5000	16,5000	3,5000	-6,5000	-4,5000	7,5000	12,2500	42,2500	20,2500	56,2500
16,2500	16,2500	16,2500	16,2500	-2,2500	3,7500	3,7500	-5,2500	5,0625	14,0625	14,0625	27,5625
1,7500	1,7500	1,7500	1,7500	-0,7500	2,2500	0,2500	-1,7500	0,5625	5,0625	0,0625	3,0625
0,5000	0,5000	0,5000	0,5000	-0,5000	0,5000	0,5000	-0,5000	0,2500	0,2500	0,2500	0,2500

$$X^2 = \sum \frac{(f_o - f_n)^2}{f_n}$$

$$X^2 = \frac{(f_{o1} - f_{n1})^2}{f_{n1}} + \frac{(f_{o2} - f_{n2})^2}{f_{n2}} + \frac{(f_{o3} - f_{n3})^2}{f_{n3}} + \frac{(f_{o4} - f_{n4})^2}{f_{n4}}$$

$$X^2 = 1,8754 + 6,8188 + 2,6284 + 7,3552$$

$$X^2 = 18,68$$

Based on Table 6, it is obtained that the Chi-Square Test value is 17.2848, then compare the calculated Chi-Square with the Chi-Square table at a certain degree of freedom (DF) and a certain level of significance.

$$DF = (r - 1) \times (c - 1)$$

where r = row and c = column

$$DF = (4 - 1) \times (4 - 1) = 9$$

In the Chi-Square table with a critical mass of 0.05 and a degree of freedom (DF) 9, the value is 18.68. Because of the Chi-Square statistic > Chi-Square table, there is a significant relationship between Priority Road Development and regional development in South Labuhanbatu Regency. This result reinforces previous research that priority road development has a significant relationship to development in an area. The construction of road infrastructure will make the wheels of economic growth which in turn will increase higher economic activity. In the process, road infrastructure can reduce transportation costs and result in increased demand for goods and services. Road infrastructure development has a role, among others, as a catalyst between the production, market, and final

consumption processes and has an important role as social overhead capital. Road infrastructure development is also capable of creating jobs and having a multiplier effect on the industry.

The Development of Priority Roads in the South Labuhanbatu Regency will connect the two economic poles. Both in Kotapinang which is the center of the economy with the sub-district capital in South Labuhanbatu Regency as the sub-center of the economy. The main objective of road construction is to realize development justice by the potential that can improve the community's economy and foster new economic points and facilitate the distribution of goods from one region to another so that market prices throughout the South Labuhanbatu Regency are reasonable. So that the people of South Labuhanbatu Regency can meet their economic, social, educational, and health needs.

5. CONCLUSION

After analyzing the road development priorities of South Labuhanbatu Regency based on input, information, data, and analysis results, it shows that priority road development has significant implications for regional development as seen from Regional Potential Development (PPW), Strengthening of Oil Palm Agriculture (PPKS), Strengthening Industrialization Local Commodities (PIKL) and Smooth Transportation of Goods and People (KTBO).

**REFERENCE**

1. Azis, Rudi dan Asrul. 2012. *Pengantar Sistem dan Perencanaan Transportasi*. Yogyakarta: Deepublish.
2. Badan Pusat Statistik Kabupaten Labuhanbatu Selatan. 2019. *Kabupaten Labuhanbatu Selatan Dalam Angka Tahun 2019*. Kotapinang: BPS Kabupaten Labuhanbatu Selatan.
3. Bachtiar Hasan Miraza. 2006. *Perencanaan dan Pengembangan Wilayah*. ISEI. Bandung.
4. Erlina. 2011. *Metodologi Penelitian*. Medan: USU Press
5. Hotrin, Rado, 2011. *Analisis Prioritas Penanganan Jaringan Jalan Strategis Terhadap Pengembangan Wilayah di Kabupaten Humbang Hasundutan*. Tesis Magister Perencanaan Pengembangan Wilayah dan Pedesaan Program Pasacasarjana Universitas Sumatera Utara, Medan.
6. Jayadinata, 1992. *Tata Guna Tanah dalam Perencanaan Pedesaan, Perkotaan dan Wilayah*. ITB, Bandung.
7. Kabupaten Labuhanbatu Selatan. 2016. *Keputusan Bupati Labuhanbatu Selatan Nomor : 600/209/DPU-LS/2016 tentang Penetapan Status Jalan Kabupaten Labuhanbatu Selatan*.
8. Kamaludin, Rustian. 2003. *Ekonomi Transportasi (karakteristik, teori, dan kebijakan)*. Ghalia Indonesia. Jakarta.
9. Kementerian PUPR. 2018. *Informasi Statisitik Pekerjaan Umum & Perumahan Rakyat*. Jakarta: Pusat Data dan Teknologi Informasi.
10. Kementerian PUPR. 2017. *Hakekat Infrastruktur dan Pengembangan Wilayah*. Bandung: Pusdiklat Jalan, Perumahan, Permukiman dan Pengembangan Infrastruktur Wilayah (JPPIW).
11. Permana, L. 2011. *Perencanaan Pembelajaran Ekonomi*. Bandung. Lab. Pendidikan Ekonomi dan Koperasi UPI Bandung.
12. Rani, Hafnidar. 2017. *Development Priority of Road Infrastructure The Aceh Post Tsunami in Simeleu District*. *International Journal of Civil Engineering (IJCE)*, 6 (3), 1-12.
13. Rustiadi Ernan, Saefulhakim Sunsun dan R.Panuju Dyah. 2011. *Perencanaan dan Pengembangan Wilayah*. Jakarta. Crestpent Press dan Yayasan Pustaka Obor Indonesia.
14. Saaty, Thomas L., (2000). *Fundamental of Decision Making and Priority Theory with The Analytic Hierarchy Process*. Pittsburgh: RWS Publication.
15. Sembiring, Irwan, 2011. *Studi Penentuan Prioritas Peningkatan Ruas Jalan (Studi Kasus : Ruas Jalan Provinsi di Kabupaten Samosir)*. Tesis Magister Perencanaan Pengembangan Wilayah dan Pedesaan Program Pasacasarjana Universitas Sumatera Utara, Medan.
16. Sirojuzilam. 2015. *Pembangunan Ekonomi Regional*. Medan: USU Press.
17. Sugiyono. 2009. *Metode Penelitian Kuantitatif Kualitatif dan R & D*. Bandung: Alfabeta.
18. Todaro, M.P. dan Smith Stephen. C. 2003. *Pembangunan Ekonomi di Dunia Ketiga*. Edisi kedelapan. Jilid 2. Jakarta: Erlangga.



ANALYSIS OF GREEN OPEN SPACE DEVELOPMENT, TEBING TINGGI KOTA SUB-DISTRICT, TEBING TINGGI CITY

Meilina Daulay¹

*¹Department of Regional and Rural Development Planning, University of Sumatera Utara,
North Sumatra, Indonesia*

Agus Purwoko²

*²Department of Regional and Rural Development Planning, University of Sumatera Utara,
North Sumatra, Indonesia*

Sirojuzilam³

*³Department of Regional and Rural Development Planning, University of Sumatera Utara,
North Sumatra, Indonesia*

ABSTRACT

The study aims to analyze and determine the suitability of the location for the development of green open spaces (GOS) in responding to the demands of Law no. 26 of 2007 using the ArcGis application with the Union / Overlay method. Based on the research results, it is known that the public GOS in Tebing Tinggi Kota District covers an area of 2.287 hectares or 0.88% of the total usage area of Tebing Tinggi Kota District. The need for public GOS in Tebing Tinggi Kota District is 1.81% or 6.28 Ha, while the provision of public GOS for Tebing Tinggi Kota Subdistrict by the direction of Law Number 26 Year 2007 is 20% of the total area.

KEYWORDS: *Green Open Space, Tebing Tinggi Kota Sub-district, Union/Overlay method*

1. INTRODUCTION

Cities are a network system of human life characterized by a high population density and characterized by heterogeneous socio-economic strata and materialistic features (Zahnd, 2008). One of the physical needs of urban communities is the availability of public spaces, which are part of green open spaces. Each city is expected to make arrangements for public space areas, and compiled in the City Spatial Planning (RTRW). The rise in population density would affect the conversion of land into built and undeveloped areas, thus reducing the proportion of green open space and making it hard to function optimally. This would also have an effect on the sustainability of the climate, which, due to the decrease of green open space, appears to be less than ideal.

The need for GOS provision has been stipulated in the Law of the Republic of Indonesia

No.26 of 2007 Article 29 paragraph 1-3 concerning Spatial Planning where it is determined that the area of urban GOS is at least 30% of the total city area. The 30% amount consists of 20% for public GOS and 10% for private GOS. The distribution of Public GOS, covering 6% green lines, 12.5% garden GOS and 1.5% GOS for certain functions (Utami, 2011).

Kota Tebing Tinggi is a municipality formed under the Law of the Republic of Indonesia No. 9 of 1956 concerning the creation of Kota Tebing Tinggi. The direction of the spatial structure plan for the City of Tebing Tinggi Regional Spatial Plan, that Tebing Tinggi City is designated as a Regional Activity Center (PKW) which functions to serve provincial or several regency/city scale activities.

Tebing Tinggi Kota Subdistrict is one of the two new sub-districts resulting from the expansion based on the Regional Regulation on the City of



Tebing Tinggi number 15 of 2006 concerning the Establishment of Sub-Districts and Villages in Tebing Tinggi City. The pattern of spatial use in Tebing Tinggi Kota Sub-district has \pm 70% of the built land of the entire Tebing Tinggi Kota Sub-district. It is because of Tebing Tinggi Kota Subdistrict in the city center in Tebing Tinggi City, which has an area of 3.4732 km² with a population of 25,107 people. Tebing Tinggi Kota sub-district has several functions, including as a residential center, government center, education center, trade and service center, health center.

In Tebing Tinggi Kota Subdistrict, it describes quantitatively the need for GOS both ecologically, aesthetically, and socially, so there is a need for GOS Development Analysis in Tebing Tinggi Kota District, Tebing Tinggi City

2. RESEARCH METHODOLOGY

In principle, data collection activities are used to describe the existing conditions of public GOS in the Tebing Tinggi Kota District. Primary data collection obtained in this research is carried out by field observations made using tools, such as GPS (Global Position System), cameras, Geo-Eye 1 Satellite Imagery (recording year February 2016), modes of transportation, drones, measuring instruments. Others.

Secondary data collection is carried out by institutional surveys, in particular by secondary surveys of relevant organizations, including the National Statistical Agency (BPS), the Regional Planning Agency for Development (Bappeda), the Public Works Office, the Business Service, the Hygiene and Gardening Service, and other entities related to this study.

Table 1
Data Requirements

No	Data description	Type of data	Form	Year	Source
1	An overview General territory studies (Tebing Tinggi Kota sub-district)	Secondary	Data and Map	Latest	- Bappeda - Public works office
2	Population	Secondary	Data	Time Series (5 Year last)	- BPS
3	Availability GOS	Primary/Secondary	Data dan Peta	Latest	- DKP office Observation Data field
4	Management GOS	Secondary	Data		- DKP office

Source: Analysis, 2016

The analysis used in this research is descriptive-evaluative analysis. To find out the need for the area of public GOS in Tebing Tinggi Kota Subdistrict, namely the source of the RTRW and the results of the dissertation in the field in response to the demands of Law Number 26 of 2007 using the standard needs as outlined in the Minister of Public Works Regulation No. 5 / PRT / M / 2008 concerning Guidelines for the Provision and Utilization of Green Open Space in Urban Areas.

The study used in the identification of public GOS in the sub-district of Tebing Tinggi Kota is to define the area of GOS in the sub-district of Tebing Tinggi Kota that comes from the Regional Spatial Plan (RTRW) and to identify land uses in the sub-district of Tebing Tinggi Kota.

Using ArcMap 10 software with geoprocessing tools (Overlay - Union), the spatial analysis was carried out to assess land-use changes from mangroves to residential land use and to determine the typology of land use in the Tebing Tinggi City Spatial Plan. A scoring tool or an assessment of various parameters where the parameters used are relevant to the research objectives is required to identify locations and areas that can be developed into GOS. The existing land use map and the developed and unbuilt land map are the parameters that will be used.

3. LITERATURE REVIEW

There are elements of Open Space, including hard elements and soft elements. Hard elements, such as road and building paving, while soft elements are



different varieties of plants. An open space, which consists mainly of soft elements, is known as GOS (Hakim, 2000). In the Director-General of Spatial Planning (2006), according to Rustam (2004), GOS is an area that is overgrown with numerous plants in different strata, ranging from ground cover, shrubs and trees (tall, woody plants).

In general, GOS has or has a main (intrinsic) function, namely ecological functions and additional (extrinsic) functions. Within an area, these main functions can be combined according to the needs, interests, and sustainability of the city, such as protection of water systems, ecological balance, and biological conservation.

The provision of GOS in urban areas is divided into 2 (two), namely:

1) Provision of GOS based on area.

The provision of GOS based on the urban area is as follows:

1. Green open space in urban areas consists of public GOS and private GOS,
2. The proportion of GOS in urban areas is at least 30% consisting of 20% public GOS and 10% consisting of private GOS,
3. If the area of GOS, both public and private in the city concerned, has a total area greater than the prevailing regulations or laws, then this proportion must be maintained.
4. The proportion of 30% is the minimum measure to ensure the balance of the city's ecosystem, both the balance of the hydrological system and the balance of the microclimate, as well as other ecological systems that can increase the availability of clean air needed by the community, and at the same time can increase the aesthetic value of the city.

2) Provision of GOS Based on Total Population.

It is achieved by calculating the number of people served by the GOS region standard according to the relevant regulations to decide the area of GOS based on the population number.

Provision of GOS based on the need for certain functions has a function as protection or security, facilities, and infrastructure, for example protecting the preservation of natural resources,

protecting pedestrians, or limiting the development of land use so that its main function is not disturbed. GOS this category includes: green line

The development of GOS in big cities, such as Singapore, with an area of 625 km² and a population of 3.6 million in 2000 and a density of 5,200 people / km², is projected to have built-up space reaching 69% of the total city area. In the plan, 24% or 177 km² is outlined as open space, so that the standard of open space reaches 0.9 ha per 1,000 people. Tokyo carried out GOS repairs on green roads, industrial estates, hotels, and the closure of several roads. Even though the city of Tokyo is very limited, the city government is still working on these parks, which have a standard of 0.21 ha per 1,000 people.

Provision of Green Open Space in Urban Areas:

In Buildings / Housing: GOS in buildings/housing both in yards and office yards, shops, and business premises functions as a producer of O₂, a noise damper, and enhances the aesthetics of a building so that it looks beautiful, and provides balance and harmony between the building and the environment.

Utilization of PRH in the Environment / Settlements:

The function of GOS in the Environment / Settlements can be optimized according to the following types of GOS: (a) GOS for Rukun Tetangga Park, (b) GOS for Rukun Warga, (c) GOS for the urban village, (d) GOS for Sub-districts, (e) GOS for Pedestrian Paths, (f) GOS flyover

Utilization of GOS in Cities

GOS Certain Functions, such as (a) Green Line of Railroad Border, (b) Green Line of High Voltage Electricity Network, (c) GOS of River Border, (d) GOS of Coastal Border, (e) GOS of Raw Water Source / Springs, (f) GOS cemetery.



4. RESULT



Figure 1. Tebing Tinggi City Orientation Map

Tebing Tinggi city is one of seven cities in North Sumatra Province, which is about 78 km from the city of Medan. Tebing Tinggi City is located at 30 ° 19'00 " - 3 ° 21'00" North Latitude and 98 ° 11 - 98 ° 21 "East Longitude. Tebing Tinggi City is in the middle of Tebing Tinggi sub-district, Serdang Bedagai Regency. Tebing Tinggi City consists of 5 (five) sub-districts and 35 urban villages with an area of 38,438 km². Padang Hilir Subdistrict is the largest sub-district with an area of 11,441 km² or 29.76 percent of the area of Tebing Tinggi city. Most of the land (50.89 percent) in Tebing Tinggi city is used as

agricultural land. The administrative boundary of Tebing Tinggi city is to the north, bordering PTPN - III Kebun Rambutan, Serdang Bedagai Regency. In the south, bordering PTPN - IV Kebun Pabatu and Paya Pinang Plantation, Serdang Bedagai Regency. East side, adjacent to PT. Soefindo Tanah Besi and PTPN - III Rambutan Plantation, Serdang Bedagai Regency. In the west, bordering PTPN - III, Bandar Bejambu Plantation, Serdang Bedagai Regency. Administratively, the area of Tebing Tinggi city is 38.44 km². The administrative area of Tebing Tinggi city covers 5 sub-districts and 35 villages.



Figure 2. Tebing Tinggi City Administrative Map

Tebing Tinggi Kota sub-district is located at coordinates 03 ° 18 '30' '- 03 ° 21' 30 " North Latitude and 99 ° 9 '30' '- 99 ° 11' 30 " East Longitude with an area of 3.4732 km² with an altitude 18 m above sea level. Geographically, the Tebing Tinggi Kota sub-district is located in the middle of the Tebing Tinggi City area. As the name implies, urban centers and economic centers such as shops and others are widely

available in this sub-district. The topographic condition of Tebing Tinggi Kota subdistrict is slightly lower than that of several other sub-districts in Tebing Tinggi City. The boundaries of Tebing Tinggi Kota sub-district are to the north by Rambutan sub-district, to the south by Padang Hulu sub-district, to the west by Bajenis sub-district, to the east by Padang Hilir sub-district.



Table 2
Projections of Population in Tebing Tinggi City Sub-District 2016-2036

No	Urban village	Population	Projections				
			2016	2021	2021	2031	2036
1	Mandailing	3.085	3.208	3.904	4.939	6.5	7.03
2	Pasar Gambir	3.015	3.136	3.815	4.827	6.352	6.87
3	Rambung	5.749	5.979	7.274	9.204	12.112	13.101
4	Tebing Tinggi Lama	2.487	2.586	3.147	3.982	5.24	5.667
5	Pasar Baru	2.119	2.204	2.681	3.393	4.464	4.829
6	Badak Bejuang	3.031	3.152	3.835	4.853	6.386	6.907
7	Bandar Utama	5.299	5.511	6.705	8.484	11.164	12.075
Total		24.785	27.792	33.382	41.709	54.249	58.515

Source: Analysis, 2016

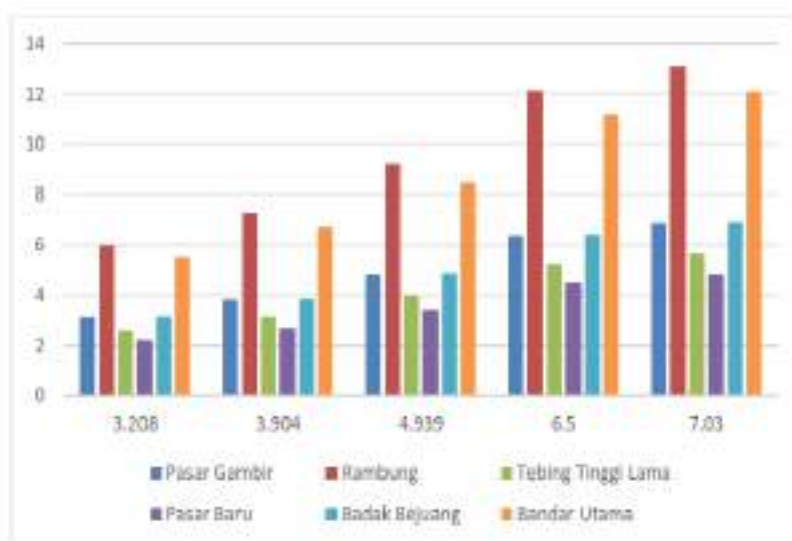

Figure 3. Population Growth of Tebing Tinggi Kota Subdistrict, 2016 – 2036

The graph above shows that population growth for the next 20 (twenty) years shows a significant difference every 5 (five) years. With the increase in population, it can indirectly affect patterns

and changes in land use and in particular vacant lands that are still likely to be converted as settlements due to the need for shelter or other activities.

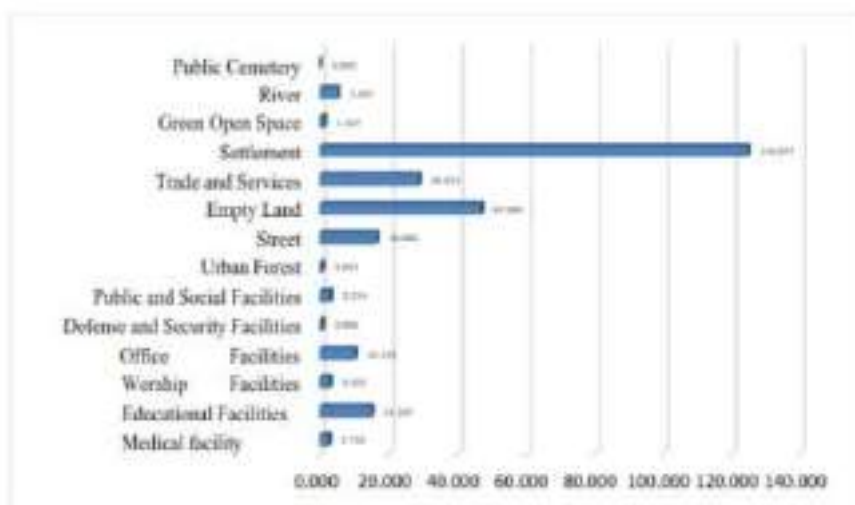

Figure 4. Land Use in Tebing Tinggi City Subdistrict in 2016

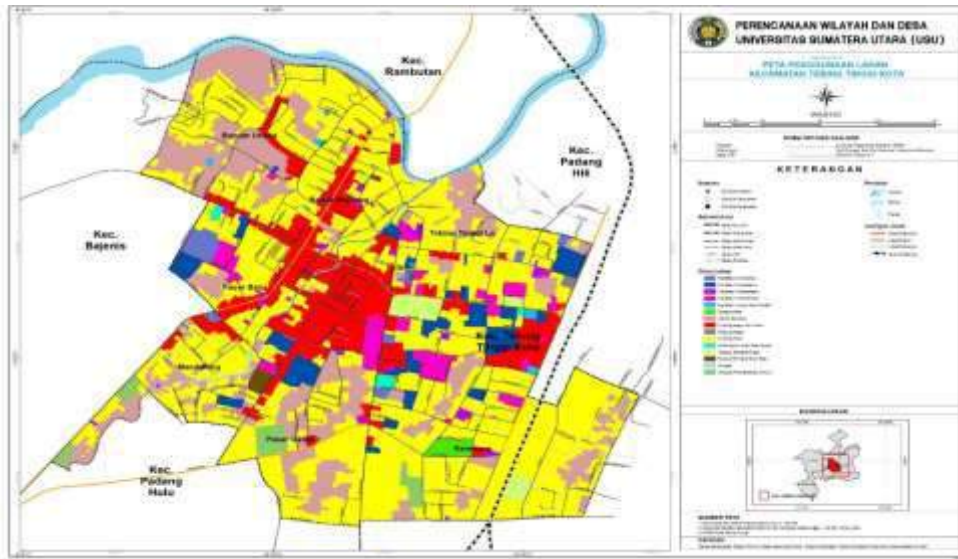

Figure 5. Land Use of Tebing Tinggi City Sub-district 2016

**Table 3
Land Use of Tebing Tinggi City Sub-district 2016**

No	Land Use	Area in Hectare	Percentage %
1	Medical facility	2.732	1.048652
2	Educational Facilities	15.197	5.832725
3	Worship Facilities	3.022	1.159771
4	Office Facilities	10.325	3.962846
5	Defense and Security Facilities	0.882	0.338422
6	Public and Social Facilities	3.214	1.233697
7	City Park	0.857	0.328796
8	Street	16.686	6.404485
9	Empty land	47.099	18.07745
10	Trade and Services	28.953	11.11276
11	Settlement	124.877	47.9298
12	Merdeka Square (Green Open Space)	1.427	0.547693
13	River	5.267	2.021732
14	Public Cemeteries	0.003	0.001169
Total		260.541	100

Source: 2016 Analysis

The existing GOS in Tebing Tinggi Kota sub-district covers an area of 2.28 hectares or 0.87% of the total use area of Tebing Tinggi Kota District, where the amount is a combination of land use for the

Public Cemetery (TPU), City Park, and Merdeka GOS Field. The existing GOS in Tebing Tinggi Kota District can be seen in (Figure 3)

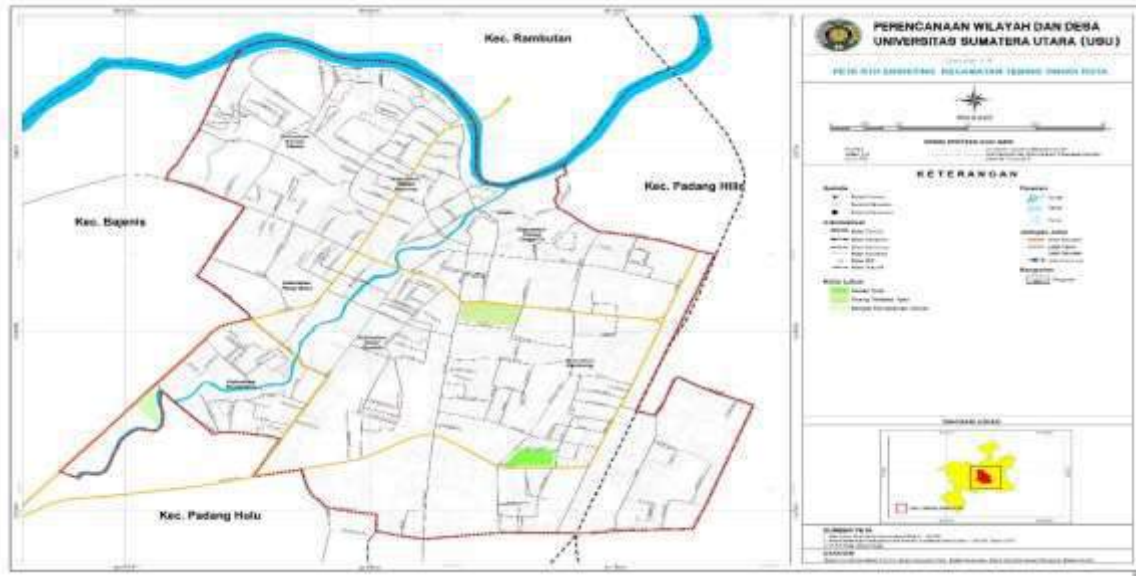

Figure 6. GOS Existing of Tebing Tinggi City Sub-district, 2016

Table 4
Area and Percentage of Public Green Open Space in Tebing Tinggi City Sub-district in 2016

No	Public Green Open Space	Area in Hectare	Percentage (%)
1	City Park	0,857	0,33
2	Merdeka Square	1,427	0,55
3	Public Cemeteries	0,003	0,00
Total		2,287	0,88

Source: 2016 Analysis

The percentage of GOS in Tebing Tinggi Kota Subdistrict by the existing conditions is not sufficient or it can be said that it is not by the GOS needs to be mandated by the Tebing Tinggi City Spatial Planning (RTRW). The GOS for the public in the sub-district is still 0.87% of the total land area. Currently, Tebing Tinggi Kota District has public GOS such as City

Park with an area of 0.85 Ha, Merdeka GOS Field with an area of 1.42 Ha, and also a Public Cemetery with an area of 0.003 Ha. The existence of public GOS is not sufficient to meet the needs of public GOS in Tebing Tinggi City, where the mandated percentage of GOS is 30% with a share of 20% for public and 10% for private.

Table 5
Directions for Green Open Space Development based on Law Number 26 of 2007

No	Regulation	Directions for GOS	
		Public	Private
1	Land area based on the direction of Law Number 26 of 2007	20% 6,28 Ha	10% 3,14 Ha

Source: 2016 Analysis

Law Number 26 of 2007 concerning Spatial Planning provides a basis for regulating green open spaces in the context of realizing safe, comfortable, productive, and sustainable urban space. Law Number 26 of 2007 states that GOS is an area that extends in the form of a lane and/or grouped area, whose use is more open, a place to grow plants, both those that grow naturally or intentionally planted.

Law No. 26 of 2007 concerning spatial planning states that 30% of the city area must be a

GOS consisting of 20% public and 10% private. Public GOS is a GOS that is owned and managed by the city/district government which is used for the benefit of the general public. Examples of public GOS are city parks, green belts, river GOS, cemeteries, and railroads. Meanwhile, private GOS is GOS owned by certain institutions or individuals whose use is for a limited group, among others, in the form of gardens or house yards/buildings owned by the community/private that are planted with plants.



So that the provision of GOS for cities by the direction of Law Number 26 of 2007 emphasizes that GOS for the public must be 20% of the total area.

5. CONCLUSION

1. Public GOS in Tebing Tinggi Kota sub-district covers an area of 2.287 Ha or 0.88% of the total utilization area of Tebing Tinggi Kota sub-district.
2. The need for public GOS that must be met by Tebing Tinggi Kota Subdistrict is 4 Ha to fulfill 6.28 Ha of the total area.
3. Provision of GOS for Tebing Tinggi Kota Subdistrict by the direction of Law Number 26 the Year 2007 emphasizes that GOS for the public must be 20% of the total area of 6.28 Ha.

REFERENCE

1. Budihardjo, E. 2003. *Kota Berwawasan Lingkungan*. Bandung: Alumni
2. Chapin, F. Steward, and Kaiser, Edward J, 1979. *Urban Land Use Planning*, University Of
3. Darmawan, E.2009. *Ruang Publik Dalam Arsitek Kota*. Semarang: Badan Penerbit Universitas Diponegoro
4. *Universitas Diponegoro*
5. De Chiara, Joseph and Koppelman, Lee E. 1978. *Site Planning Standards*. New York: McGraw Hill Book Company
6. Erlina, 2011. *Metodology Penelitian*. USU-Press, Medan
7. Fizera, D, 2001. *Kajian Pola Ruang Terbuka di Kota Bandung : Sebuah Produk*
8. *Budaya Akibat Perkembangan Jaman*, Majalah Ilmiah Unikom 1,2, 11-117
9. Gunadi, Sugeng, 1995. *Arti GOS Bagi Sebuah Kota*. Makalah pada Buku: *Pemanfaatan GOS Surabaya, Bahan Bacaan Bagi Masyarakat serta Para Pengambil Keputusan Pemerintah Kota*
10. Groat, Linda & Wang, David. 2000. *Architectural Research Methods*. Canada: John
11. *Wiley&Sons, inc.*
12. Hakim, R. 2000. *Tesis "Analisis Kebijakan Pengelolaan GOS Kota DKI Jakarta"*Institut Teknologi Bandung
13. Irwan, Z.2005. *Tantangan Lingkungan dan Lansekap Hutan Kota*. Penerbit Bumi
14. *Aksara. Jakarta*
15. *Kecamatan Tebing Tinggi Kota Dalam Angka, 2016. Bappeda dan Badan Pusat*
16. *Statistik Kota Tebing Tinggi*
17. Rustam, H.2004, *Arsitektur Lansekap, Manusia, Alam dan Lingkungan*, Penerbit
18. *Bina Aksara Jakarta.*
19. Rijal, S, 2008. *Kebutuhan Ruang Terbuka Hijau di Kota Makasar Tahun 2017*, *Jurnal Hutan dan Masyarakat*, Vol III,001-110.
20. *Republik Indonesia, Peraturan Menteri Dalam Negeri Nomor 1 Tahun 1987 tentang Penyerahan Prasarana Lingkungan, Utilitas Umum dan Fasilitas Sosial Perumahan Sebesar 40% dari*

Luas Area yang akan di Bangun Kepada Pemerintah Daerah.

21. Utami, R, 2011. *Tesis "Analisis Kebutuhan Taman Pemakaman Umum Sebagai Pendukung Ruang Terbuka Hijau di Kota Medan"*, Universitas Sumatera Utara, Medan.
22. Wahyudi, 2009. *Tesis "ketersediaan Alokasi Ruang Terbuka Hijau Kota Pada Orde*
23. *Kota I Kabupaten Kudus"*, Universitas Diponegoro, Semarang.
24. Zahnd, M., 2008. *Model Baru Perancangan Kota yang Konsektual*, Yogyakarta : Kanisius.



A STUDY ON CUSTOMER SATISFACTION TOWARDS THE HINDU NEWSPAPER (COIMBATORE CITY)

Mr. A David

*Assistant professor, Department of Commerce with Professional Accounting
Dr. N. G. P Arts & Science College, Coimbatore*

Mr. M.Veeramani

*III B.Com (PA), Department of Commerce with Professional Accounting
Dr. N. G. P Arts & Science College, Coimbatore*

ABSTRACT

This study said that in this modern business economy it is very important to analyses the marketing strategy used in the hindu newspaper. The study result shows the majority of the consumers are satisfied with the hindu newspaper i but also there is a drawback such as hike in price and such other factor like design of the product. If necessary steps to re-solve problems of retaining customers of the hindu newspaper will be high. It will develop the strategy of marketing, if the company can understand the preference and overall perception of the consumer. Hence, it will develop the marketing strategy and market share of the hindu newspaper Company.

KEY WORDS-*Customer Satisfaction, Marketing strategy, modern business economy, analyses*

INTRODUCTION

A newspaper is a periodical publication containing news regarding current events, informative articles, diverse features, editorials, and advertising. It is usually printed on relatively inexpensive, low-grade paper such as newsprint. By 2007, there were 6,580 daily.

The Hindu Newspapers in the world selling 395 million copies a day. Newspapers typically publish stories on local and national political events and personalities, crime, business, entertainment, society and sports. Most traditional papers also feature an editorial page containing editorials written by an editor and columns that express the personal opinions of writers. The newspaper is typically funded by paid subscriptions and advertising. The Hindu is an English-language Indian daily newspaper. Headquartered at Chennai (formerly called Madras)

The Hindu was published weekly when it was launched in 1878, and started publishing daily in 1889. According to the Indian Readership Survey in 2012, it was the third most widely read English newspaper in India (after the Times of India and Hindustan Times), with a readership of 2.2 million people. The Hindu has its largest base of circulation in southern India, especially in the states of Tamil

Nadu and Kerala, and it is also the most widely read English daily in Tamil Nadu and Kerala. The Hindu was the first newspaper in India to have a website, launched in 1995. On 15th August 2009, the 130-year-old newspaper launched the beta version of its redesigned website at beta.thehindu.com. This was the first redesign of its website since its launch. On 24 June 2010 the beta version of the website went fully live at www.thehindu.com.

STATEMENT OF PROBLEM

We known well Knowledge is power to all the human beings “In today’s world there is an increasing demand of knowledge. The people have chosen the news paper as one of the source for developing the knowledge. Most of them have preferred the newspapers for gathering the news. And they consume newspapers at every morning. At the same time their thought is it’s one of the less expensive media compare with others meanwhile no one could not carry the other source of media at everywhere except newspapers. Although the print media will become very competitive throughout the country. This study analysis the consumer satisfaction toward The Hindu Newspaper special preference in Coimbatore city.



SCOPE OF THE STUDY

Newspapers are a mirror of public opinion too. Through their columns, the public can present their views on subjects of national and international issues. Letters to the Editor is one very important part of a newspaper. Business houses also make great use of the newspapers to advertise their products and to reach out to their customers. The alluring advertisements have a great impact on popular mind and that is the purpose of such advertisements. But there is one great responsibility which devolves upon the newspapers because the study is overall consumer satisfaction towards The Hindu Newspaper special preference in Coimbatore city. The data will be collected through questionnaire only in Coimbatore city.

OBJECTIVE

- To study the consumer preference towards The Hindu Newspaper in coimbatore city.
- To know the consumer preference towards supplement issued by The Hindu News paper.
- To analyze the buying behavior and reading time.
- To find out the satisfaction of availability of THE HINDU Newspapers.

REVIEW OF LITERATURE

Mrs. Ruchita Ramani, Mr Sagar Dhabade (2013)¹ in their study- "The Study of Consumer Behaviour with Special Reference to Business Standard Newspaper" Our research paper is based on the study of overall consumer behaviour towards selection of financial newspaper with special reference to Business Standard Newspaper in Pune. The study of consumer behaviour helps organizations in improvisation of their marketing strategies by understanding the consumer's psychology while evaluating different alternatives and selecting the best one available. The study also emphasizes on environmental factors influencing the buying decision. This study helps the firms to know about the customer's needs and provide customized products as desired by the customers thereby leading to customer satisfaction and boost in the sales

G. Purushothaman & K. Krishnamurthy (2015)² in their study- "a study on consumer satisfaction towards "the hindu" newspapers (with special reference to kanchipuram district)" Customer satisfaction is the main thing for promoting the sales because the consumer is the king of every business. So, the every manufacturer has must needed to satisfy their customers. The

RESEARCH METHODOLOGY

A Research methodology or involves specific techniques that are adopted on research process to collect, assemble and evaluate data. It defines these tools that are used to gather relevant information in a specific in a research study.

PRIMARY DATA

Primary data are collected by way of distributing questionnaires to the customer in The Hindu Newspaper.

SECONDARY DATA

Secondary data is collected from Articles, Magazine & Book and website

AREA OF THE STUDY

It is limited to Coimbatore city

LIMITATION

- The time allocated for the study is only 3 months.
- The study is only limited to Coimbatore city.
- The sample size was limited to 150 customers due to time constrains.

manufactures cannot easily to satisfying their customers. So, the manufacturer must understand of the customer needs, they need have fulfilled the customer, so the researcher has chosen the interesting topic for measuring the consumer satisfaction towards newspapers.

HISTORY OF THE HINDU NEWSPAPER

The newspaper and other publications in the Hindu groups are owned by the family – held company, Kasserri and sons Ltd. In 2010 the newspaper employed over 1600 works and annual turnover reached almost 200 million. According to data from 2010 most of the revenue comes from advertising and subscription. The Hindu become in 1995, the first Indian newspaper after an online edition. As of march 2018 it is published from 21 locations across 11 states, Bangalore, Chennai, Hyderabad, Thiruvananthapuram, Vijayawada, Kolkata, Mumbai, Coimbatore, Madurai, Naiad, Visakhapatnam, Kochi, Mangalore, Hubble, Mohall, Allahabad, Kozhikode, Luck now, Cuttack, Patna and Tirupathi.

The Hindu was founder in madras on 20 September 1878 as the weekly Newspapers of the period established to protest the policies of the British Raj. About 100 copies of the inaugural issue were printed at Srinithi press, Georgetown on one rupee and Twelves annals of borrowed money.



Subramanian Ayer became the first editor and Vera Raghavacharya, the first managing director of the newspaper

The Hindu has its largest base of circulation in south India, especially in the states of Tamil Nadu and Kerala, and it is also the most widely read English daily in Tamil Nadu and Kerala.

The Hindu was the first newspaper in India to have a website, launched in 1995. On 15th August 2009, the 130-year-old newspaper launched the beta version of its redesigned websites at beta.thehindu.com. This was the first redesigned of its launch. On 24 June 2010 the beta version of the website went fully live at www.thehindu.com

The Hindu Home till 1939, there issued a guard – size paper with a front page full of advertisements, - a practice that came to an end only in 1958 when it followed the lead by its idol, the pre-Thomson Times- and three back papers also at the service of the advertiser. In between, there were more views than news. It was headed by G.Kasuturi from 1965 to 1991. N.Ravi from 1991 to 2003 and by his brother N.Ram since June 27th 2003. The present is that information which is available as right time to the

right person.

DATA ANALYSIS AND INTERPRETATION

In this chapter the analysis interpretation of the study on “Consumer satisfaction towards the Hindu newspaper “ is presented based on the opinion of sample of 120 respondents selected from Coimbatore city through a questionnaire containing 18 questions analyzed through

1. Simple percentage analysis.
2. Rank analysis method.

SIMPLE PERCENTAGE ANALYSIS

Percentage analysis is the method to represent raw stream of the data as a percentage for the better understanding of collected data. Percentage analysis is applied to create a contingency table from the frequency distribution and represent the collected data for better understanding. It is a particularly useful method of expressing the relative frequency of survey responses and other data’s.

FORMULA:

$$\text{Percentage Analysis} = \frac{\text{Number of respondents}}{\text{Total number of respondents}} * 100$$

**TABLENO:1
TABLE SHOWING THE MAIN NEWS REASONS FOR READING NEWS PAPER**

S.NO	PARTICULARS	NO OF RESPONDENTS	PERCENTAGE
1	To get the latest update and news	81	67.5
2	To pass time	31	25.83
3	Entertainment purpose	8	6.67
	Total	120	100

Source: Primary data

INTERPRETATION

The above table shows that 56.67% of the respondents are male 43.33% of the respondents were female.

REFERENCE

Majority (43.33%) of the respondents were female

**TABLE 4.1.2
TABLES SHOWING THE HOW LONG HAVE YOU READING THE HINDU NEWSPAPER**

S.NO	PARTICULARS	NO OF RESPONDENTS	PERCENTAGE
1	1 years	71	59.17
2	2 years	39	32.5
3	More than 2 years	10	8.33
	Total	120	100

(Source: Primary Data)

**INTERPRETATION**

Its is revealed that 59.17% of the respondents are 1 year and the 32.5% of the respondents are 2 year the 8.33% of the respondents are more than 2 years .

REFERENCE

Majority 59.17% of the respondents are 1 year.

LINKERT SCALE ANAYLSIS

A Likert scale is a psychometric scale commonly involved in research that employs questionnaires.

It is the most widely used approach to scaling in survey research, such that the term is often used interchangely with the rating scale.

$$\begin{aligned} \text{Likert scale} &= (\text{Fx})/\text{no of the respondents} \\ &= 548/120 \\ &= 4.5 \end{aligned}$$

Likert scale value 4.53 is greatest than the middle value (3) so the customers are satisfied with general news .

FORMULA

LIKERTSCALE =SUM OF (FX)/NUMBER OF RESPONDANTS

F =NO.OF RESPONDENTS

X =LIKERT SCALE VALUE

(FX)=TOTAL SCORE

MID VALUE

Mid-value indicates the middle most value of the likert scale.

SNO	FACTORS	NO OF THE RESPONDENTS	LIKERT SCALE VALUE	TOTAL
1	Highly satisfied	76	5	380
2	Satisfied	30	4	136
3	Neutral	9	3	27
4	Dissatisfied	2	2	4
5	Highlydissatisfied	1	1	1
	TOTAL	120		548



FINDINGS, SUGGESTIONS AND CONCLUSION FINDING

SIMPLE PERCENTAGE ANALYSIS

- ✓ Majority 56.67% of the respondents are Female.
- ✓ Majority 45% of the respondents are 41 years-50 years
- ✓ Majority 69.17% of the respondents are Married.
- ✓ Majority 52.5 % of the respondents Educational qualification is degree.
- ✓ Majority 42.5% of the respondents employee.
- ✓ Majority 56.67% of the respondents of the earning Rs.20,001-Rs.30000
- ✓ Majority 61.67% of the respondents are nuclear.
- ✓ Majority 36.67% of the respondents are four members.
- ✓ Majority 75.85% of the respondents are collect newspaper.
- ✓ Majority 32.15% of the respondents are sensational news.
- ✓ Majority 47.5% of the respondents are others.
- ✓ Majority 66.67% of the respondents are good.
- ✓ Majority 60% of the respondents are neutral.
- ✓ Majority 43.33% of the respondents are interesting and innovation.
- ✓ Majority 51.67% are strongly agree.
- ✓ Majority 56.67% of the respondents are 30min to an hour.
- ✓ Majority 59.17% of the respondents are alternative days.
- ✓ Majority 67.5% of the respondents are to get the latest updates and newses.
- ✓ Majority 59.17% are one year.
- ✓ Majority 81.67% are the respondents are yes.
- ✓ Majority 35 are the respondents are business line.
- ✓ Majority 60% of the respondents are easy language.

LINKERT SCALE METHOD

- ✓ Linkert scale value 4.53 is greater than the middle value(3), so the customer are
- ✓ Satisfied with the general news.
- ✓ Linkert scale value 3.167 is greater than the middle value (2), so the customer are
- ✓ Satisfied with the field news.
- ✓ Linkert scale value 4.55 is greater than middle value(3),so the customer are satisfied with the employment news.
- ✓ Linkert scale value 3.48 is greater than the middle value(2),so the customers are satisfied with the quality of the paper.

- ✓ Linkert scale value 2.75 is greater than the middle value (1),so the customer are satisfied with the quality of painting.

SUGGESTIONS

Thus study suggested that the marketing techniques and strategies can be improved for The Hindu newspaper. Most of the respondents came to know about the Hindu newspaper services only through the family members and friends. The study suggested that the design of the mobile phone can be further improved. To price offers / discount offers to attract more member of customers.

CONCLUSION

This study concluded that in this modern business economy it is very important to analysis the marketing strategy used in the Hindu newspaper services. The study result shows the majority of the consumers are satisfied with the Hindu news paper taxi services but also there is a drawback such as hike in price and such other factor like design of the product. If necessary steps to re solve problems of retaining customers of Hindu newspaper services will be high. It will develop the strategy of marketing, if the company can understand the preference and overall perception of the consumer. Hence, it will develop the marketing strategy and market share of Hindu newspaper services.

REFERENCE

1. Mrs. Ruchita Ramani, Mr Sagar Dhabade and Mrs.Vatsala Manjunath. *The Study of Consumer Behaviour with Special Reference to Business Standard Newspaper, IBMRD's Journal of Management and Research 2013 ;369 – 380.*
2. G. Purushothaman & K. Krishnamurthy. *a study on consumer satisfaction towards "the hindu" newspapers (with special reference to kanchipuram district), Journal of Human Resource Management and Development (JHRMD),2015; 79-86*
3. Meharaj Banu, r. Malini, G. Sreerangam *A study on customer satisfaction towards daily newspaper with special reference to daily thanthi in tiruchirappalli city, Asia Pacific Journal of Research 2015 ;19-24*
4. Margareta Fireman and Markus Felleson. *Service Supply and customer satisfaction in public transportation. Journal Of Public Transport (JPT). 2009; 57-69*Dr.V. Balaji, A. Usha. *a study on consumer preference towards "the hindu" newspaper, International Journal of Business and Administration Research Review 2018 ;64-73*
5. Dr. Karuna Gole. *A Study of Customer Preference for Newspaper Brands in Pune Region*



*International Journal of Management, Technology
And Engineering ,2018 ;6045– 6077*

6. *Vijaya. R, Dr. Srinivasan. a study on readers' satisfaction on Online newspaper services in Coimbatore city, EPRA International Journal of Economic and Business Review,2018 ;49-52.*



A STUDY ON CUSTOMER SATISFACTION TOWARDS UBER CAB SERVICES IN COIMBATORE CITY

Dr. R. Mayilsamy

*Assistant Professor, Department of Commerce with Professional Accounting,
Dr.N.G.P. Arts and Science College, Coimbatore*

Karthic. R.S

*Student of III B.Com (PA), Department of Commerce with Professional Accounting,
Dr.N.G.P. Arts and Science College, Coimbatore*

ABSTRACT

Every other day in India, there is a new startup offering efficient cab services to the citizens operating in urban and rural lifestyles. This raises a question that is India going through a possible Cab Revolution??? In this paper an attempt has been made to study the customer satisfaction level of the people who are using UBER cabs in Coimbatore city. In the paper it shows the convenience and Service quality in Uber cabs. This articles seeks to understand the dynamics of market pricing, service quality, and various factors, etc. For the purpose of the study, a convenient sampling survey was conducted among 120 respondents in Coimbatore city with the help of e-questionnaire. The tools used for this study are simple percentage analysis, Likert scale analysis, and Rank analysis.

KEYWORDS: *Service quality, UBER, Cab Services, Simple percentage analysis, Likert scale analysis, Rank analysis.*

INTRODUCTION

The Indian cab marketing is forecast to grow at a GAGR of 76% during 2017-2021. The organized sector in the recently emerged segment in the market scenario. In the past decade the transportation facilities in urban areas have undergone tremendous changes of transportation the cabs have become important among various modes mode of transportation in metropolitan and urban cities in India.

The growth of organized cab rental industry is continuously growing with support of technology. The customers in the present era are using mobile apps to book a cab at any time and from any place in urban areas. The pricing strategy of cab operators had been positively influencing customers to book a cab instead of traditional mode of transportation like autos and local buses etc. Like most of the industries the cab industry

had underwent lots of transformation with internet technology. The consumers are able to access book cabs at competitive prices because of tough competition among the organized cab operators. In this regard the present paper briefs about the behavior of consumers while booking cabs. The variables like coupon redemption, innovativeness and price consciousness.

STATEMENT OF THE PROBLEM

Coimbatore has a lot of UBER call cabs which are facing tough competition in today's world. The competition among all the cabs have also improved and lost in the best services to their expecting Customer. The study is to put light on the need of the public for cabs and valuable services provided by all cabs. This also help to know about the psychology of the people in preferring a Particular cab services. The study is to



know people prefer UBER call taxis, than other modes of the transport and impact made by the cab services on the public.

OBJECTIVES OF THE STUDY

- To study the factors influencing the choice of UBER cab services.
- To analysis the level of satisfaction of the customers towards UBER cab services.
- To know the problems faced by the customers while using the UBER cab services.

RESEARCH METHODOLOGY SOURCE OF DATA

- Primary data is used in the study. It is original data for the purpose of collection of primary data, e-questionnaire were filled by the respondents. The e-questionnaire comprises of close ended.
- The secondary data was collected from various possible records like books, magazines, periodicals and websites.

RESAERCH DESIGN

- **Sampling technique**
The sampling technique used in this study was convenient sampling.
- **Sample size**
The study was conducted with a sample size of 120 respondents.
- **Area of study**
The study was undertaken in Coimbatore city.

TOOLS FOR ANALYSIS

- Simple percentage method
- Likert scale analysis
- Rank analysis

LIMITATIONS

- The study is limited to 120 respondents.
- The study was focused only in the Coimbatore city

- Finding of the study purely depend upon the responses given by the respondents.

REVIEW OF LITERATURE

Ashish avinash khade(2018) – Thus, 1992 define relationship marketing as-an integrated effort to identify, maintain and build up to Network with the individual customers and to intensity and continuously strengthen the Network in mutual benefit of both side through interactive and individually and value added contracts over a long period of time. Customer so that company better utilize its resources on those customer it can maintain it serve better and create mutual value.

S. M. Yamuna, (2019) –In the current Scenario he best and the way to travel to the bus stand, Railways stations and the airports and to the other places and the by call taxi. There is the as Coimbatore in the 40 and 50 call taxi and the other places and maintain available and maintain the subsrbs and the mostly 4 hours within the day. And the people and maintain the confident way to travel and influencing and the choice maintain the problem faced by people satisfaction and the taxi and the problem and people using call taxi services.

Rukhsana Rasheed (2006) – Satisfaction is an individual perception either they are satisfy or dissatisfy based and the expectation towards and the product and the maintain service performance. In line with the perception and customer satisfaction and the reflect of from the disconfirmation theory of customer expectation and the maintain the positive disconfirmation and the negative satisfaction leads to dissatisfaction.

DATA ANALYSIS AND INTERPRETATION

The chapter deals with analysis and interpretation of the study “A Study on customer satisfaction towards Uber cab services in Coimbatore City”. Based on the data collected, the collected data have been analyzed using the following statistical tools.

- Simple Percentage Analysis
- Likert Scale Analysis
- Ranking Analysis



TABLE 1 - TABLE SHOWING RESPONDENTS AWARENESS OF CAB/TAXI SERVICES

Kinds of cab	No. of Respondents	Percentage %
Red taxi	16	13.3
Ola cab	40	33.3
Uber cab	53	44.2
Fast track taxi	11	9.2
Total	120	100

Source: Primary Data

Interpretation

The table reveals that 44.2% of the respondents are aware about the Uber cabs, 33.3% of the respondents are aware about ola cab, 13.3% of the respondents are aware about the red taxi and 9.2% of

the respondents are aware about the fast track taxi.

- Majority 44.2% of the respondents have aware about the Uber cab services.

TABLE 2 - TABLE SHOWING THE RESPONDENTS WITH SATISFACTION LEVEL OF UBER CAB SERVICES

Factors	No. of respondents	Likert's scale	Total score (fx)
Highly satisfied	10	5	50
Satisfied	60	4	240
Neutral	35	3	105
Dissatisfied	15	2	30
Highly dissatisfied	0	1	0
Total	120	15	425

Source: Primary Data

$$\begin{aligned} \text{Likert scale} &= \sum(\text{fx}) / \text{Total number respondents} \\ &= 425/120 \\ &= 3.6 \end{aligned}$$

Interpretation:

Likert's scale value is 3.6 is more than mid value (3). Hence the majority of the respondents are satisfied in using their cab service provided by uber cabs.



RANK ANALYSIS

TABLE – 3 SHOWING RESPONDENTS WITH RESPECT TO THEIR OPINION ABOUT THE UBER CAB SERVICES

Factors	R1	R2	R3	R4	R5	Total	Final Rank
Fast pickup /drop	52(5)	35(4)	28(3)	5(2)	0(1)	494	2
Comfort	50(5)	45(4)	15(3)	10(2)	0(1)	495	1
Convenience of booking	55(5)	10(4)	25(3)	18(2)	12(1)	438	4
Diver interaction	35(5)	47(4)	10(3)	5(2)	23(1)	426	5
Reasonable fare	27(5)	53(4)	25(3)	10(2)	5(1)	447	3

Source: Primary Data

Interpretation

The above table shows that, comfort is ranked first (1), fast pickup and drop is ranked second (2), Reasonable fare is ranked third (3), convenience of booking is ranked fourth (4), driver interaction is ranked fifth(5).

Inference:

The Comfort of travel have been ranked 1st by the respondents and their opinion while travelling.

FINDINGS

SIMPLE PERCENTAGE ANALYSIS

- 77% of the respondents are in the age group of 20 -35 years.
- 55% of the respondents are male.
- 73% of the respondents are unmarried.
- 78 % of the respondents educational qualification is graduate level.
- 44% of the respondents are student.
- 32% of the respondents earn less than Rs.10000.
- 44% of the respondents have aware about the Uber cab services.
- 46% of the respondents are booking over the mobiles.
- 41% of the respondents are travel on the cab during the occasions.
- 35% of the respondents are using for the purpose of doorstep pickup and drop.
- 37.5% of the respondents think of comfortable travel.

- 31% of the respondents are using the reason for comfort travelling.
- 37% of the respondents are getting offers in sometimes while travelling.
- 31% of the respondents are using frequently for comfortable travelling. 34.5% of the respondents are pay through all the above methods.
- 42.4% of the respondents prefer uber cab arrive on time for pickup and drop.
- 53.3% of the respondents are not facing the major problems while travelling on the uber cabs.
- 59.2% of the respondents are spending amount Rs. 200 -400 for uber cab services.
- 40.7% of the respondents are prefer for easy availability services.

LIKERT SCALE ANALYSIS

- Likert's scale value is 3.6 is more than mid value (3). Hence the majority of the respondents are satisfied in using their cab service provided by uber cabs.

RANK ANALYSIS

- It is observed that the **Comfort** is ranked first.

SUGGESTIONS

There are a few suggestions made to improve the service quality of Uber Cab service.

- The offers and discounting on fare should



be improved in services provided by Uber Cabs.

- Advertisement through various media's can be made to make the customer to recall the uber cab services. The suggestion is made from this study is that, the interaction of cab driver.
- attitude and way of treat the customers and behaviour should be reverence.
- To improve some technology in the application for customer convenience of booking Uber Cabs.
- To provide better deals for customers and offer/ discount while travelling in the cab.
- To make the proper guidance in online transactions.
- Cleanliness should be maintained in the cab services.
- Respondents feels that the price of Uber cabs is too high. They anticipate a reduction in price, which can be affordable in the common class people.
- They feels that the speed level in the cab should be increased.
- The above factors can be helps in frame a new image and make a attention among the customers for its services.
- The innovative customers are interested to adopt for new technology like use apps for booking cabs and other services.

CONCLUSION

Now- a- days cab is the best way to transport, while comparing to another mode of transport, cab services is the best and safest mode of transport. There is stringent competition in the organized cab services industry need to motivate customers through the services. There is many cab services provided the services towards the customers and their satisfactions. The brand image also plays a vital role in customer retention apart from offering the services. Currently Uber is a major player in the organized cab sector in India. In spite of that there is some negative responses were come from the respondents about the Uber Cab services like speed level of pickup, quality of services, provide discount and offers on fare, accessibility. Thus, the recommends helps to frame image and survive among the customers for its services. The report also concluded that Uber is Best cab services with high customer satisfaction, economy, safety and recommend to friends and family across India.

REFERENCE

Journal References

1. *Ashish avinash khade(2018) Services of the international of the taxi companies and relationship of uber*
2. *S. M. Yamuna (2019) UBER is the hattle of dominate- ISOR journal of business and management (ISSOR-JBR) VOL-9, ISSUE-9, (PP-90,98).*
3. *Rukhsana Rasheed (2006) A study on customer satisfaction towards call taxi services international journal of multidisciplinary research review, VOL1, ISSUE-3, (PP:980-981) MARCH 2006.*

WEB REFERENCES

- www.uber/profile.in
- www.olaprof.com
- <http://uberservices.co.in>
- www.uber/ola/cabservices/india.in
- www.ijraset.com



A STUDY ON COMPARATIVE LEVEL OF SATISFACTION BETWEEN GOVERNMENT BUS PASSENGER AND PRIVATE BUS PASSENGER IN COIMBATORE

¹Mrs. N. Ramya

¹Asst. Professor, Department of Commerce with Professional Accounting,
Dr.N.G.P. Arts and Science College, Coimbatore 641 048, Tamil Nadu.

²Guru Prasath. M.V

² Student of III B.Com (PA), Department of Commerce with Professional Accounting,
Dr.N.G.P. Arts and Science College, Coimbatore 641 048, Tamil Nadu.

ABSTRACT

The project entitled “A Study on Comparative Level of Satisfaction between Government bus passenger and Private bus passenger in Coimbatore” is carried out with an objective to determine the consumer satisfaction. The primary objective of this study is to find out the comparative and Satisfaction level in between Government Bus passengers and Private bus Passengers. An attempt is made in this study to have better understanding of passenger attitude and the level of passengers’ satisfaction towards services provided by both public and private sector bus transport industries. In addition to this, a brief report is made about the existing services, delivery of services, how far the passengers avail those services and the reasons if any for their preference of particular industrial services.

Further, it focuses on the measures taken by the bus transport industries to improve the level of satisfaction of passengers and to avert their problems to retain the loyalty of the passengers. The main aim of this study is to compare the services provided by public and private sector bus transport industries and to evaluate their efficiency to satisfy the needs of the passengers in an effective way. Also this study attempts to elicit the opinion of the passengers about the quality and types of services provided and grievances. In every bus transport service related businesses, there is a need to develop relationship with the passengers and with the service providers to satisfy passengers’ day-to-day service quality requirements.

KEYWORDS: Quality and Services, Public Transport, Private Transport, Attitude level of the customers, Simple percentage analysis, Likert scale analysis, Rank analysis.

I. INTRODUCTION

It is a fact that no bus transport business can exist without passengers. In every bus transport service related businesses, there is a need to develop relationship with the passengers and with the service providers to satisfy passengers’ day-to-day service quality requirements. At present, with the upgraded technology, up to the possible extent the transportation systems in different modes are developed.

Public Transport System in India

The public transportation is the primary mode of transportation for the majority of the Indian population. Public transport systems in India are among the most frequently and widely used transports system in the world.

Service Providers Operated In Coimbatore District

i. State Express Transport Corporation (SETC)

SETC has also initiated several promotional measures like introduction of online ticket booking



facilities, payment of bus tickets through credit cards, 10% discount for the senior citizens, 10% discount for group ticket booking, zero waiting time, reservation of seats for ladies, introduction of one week valid card for Rs.500/- to travel by any bus in SETC. It has earned the appreciation and received compliment from the passengers in Southern India because of its efficiency, punctuality, safety and reliability of services.

ii. Tamil Nadu State Transport Corporation (TNSTC)

Tamil Nadu State Transport Corporation (TNSTC) is a government owned bus transport unit. Cheran Transport Corporation Limited was incorporated as a Company in 1972 and it commenced its services from 1972 with 110 buses. Tamil Nadu State Transport Corporation (Coimbatore Division III) Ltd., has been merged with Tamil Nadu State Transport Corporation (Coimbatore Division I) Ltd., with effect from 2000. At present, the principal area of operation of TNSTC is both Coimbatore and Nilgiris Districts.

iii. Private Bus Transport Services in Coimbatore District

In Coimbatore, many private buses are also operated by private individual owners and other transport companies to facilitate passengers who are willing to travel in buses and to fulfill their needs. Even though more numbers of buses are operated from the government side, Private buses are also plied in more numbers to various destinations or different parts of inner and outer of Coimbatore city due to heavy demand for quantity and quality wise needs and expectations from the general public. Moreover, the passengers also prefer private buses even though the fare is too costly than the public sector buses such as SETC and TNSTC because the facilities and luxuries provided and the quicker reach to their destinations.

II. STATEMENT OF PROBLEM

In the modern period, public bus transport services, being the most indispensable, help the people for mobility. Every human being or a passenger wants to avail better and comfortable travel. It is generally believed that services of the private sector transport agencies are better than the public sector. Hence, a comparative study is attempted to ascertain the performance of the public and private bus transport service industries in Coimbatore to test the belief of the people and to find out the factors responsible for such kind of opinion

III. OBJECTIVES

1. To measure the level of satisfaction of passenger towards the services.
2. To identify, analyse and interpret the socio economic factor of passengers.

3. To examine the benefits of passenger for their journey from Coimbatore to other place.
4. To compare the satisfaction between public bus user and private bus user in Coimbatore.

IV. RESEARCH METHODOLOGY

SOURCE OF DATA

- Primary data is used in the study. It is original data for the purpose of collection of primary data, e-questionnaire were filled by the respondents. The e-questionnaire comprises of close ended.
- The secondary data was collected from various possible records like books, magazines, periodicals and websites.

RESEARCH DESIGN

- **Sampling technique**
The sampling technique used in this study was convenient sampling.
- **Sample size**
The study was conducted with a sample size of 120 respondents.
- **Area of study**
The study was undertaken in Coimbatore city.

V. RESEARCH TOOLS FOR ANALYSIS

- Simple percentage method
- Likert scale analysis
- Rank analysis

VI. LIMITATIONS

- Sample size restricted to 120 customers.
- The study was focused only in the Coimbatore city.
- Findings of the study purely depends upon the responses given by respondents.

VII. REVIEW OF LITERATURE

[1] GAJENDRAN - 2012, the study was conducted for all transport industries are trying to give good quality of service to the different level of people to satisfy the needs of passengers. But still it not possible for them to satisfy all the passengers because there is a huge gap between the population growth, passenger expectation and the services quality which is offered by the transport industries and which is expected by the general public from the service providers. The analysis was used among 75 passengers



[2] **NAGA SUBRAMANIAN & JAGADESH – 2017**, In their study defines, one of the major ways to differentiate a service firm is to deliver consistently higher quality service than competitors. The key is to meet or exceed the passengers’ service quality expectations. The collected passenger’s opinion data have been analyzed evaluating level of public transport by 120 respondents. The service provider needs to identify passengers’ wants in the way service quality.

[3] **XUAN PHUONG NGUYEN – 2019**, in his research passenger satisfaction was considered as one of the most significant and primary factor in any service and industry field because of direct relationship with passenger retention. To survey about the satisfaction the author used regression analysis and question based standards among 50 respondents. It concluded that the enhancement of the

public transport system will result in solving in problem like traffic jam, noise, accidents, and fuel consumption.

VIII. DATA ANALYSIS AND INTERPRETATION

The chapter deals with analysis and interpretation of the study “A STUDY ON COMPARITIVE LEVEL OF SATISFACTION BETWEEN GOVERNMENT BUS PASSENGER AND PRIVTE BUS PASSENGR IN COIMBATORE”. Based on the data collected, the collected data have been analyzed using the following statistical tools.

- Simple Percentage Analysis
- Likert Scale Analysis
- Ranking Analysis

1. SIMPLE PERCENTAGE ANALYSIS

TABLE-1 SHOWING THE RESPONDENTS WITH RESPECT TO THE KINDS OF BUS TRANSPORT THEY USE WHILE TRAVELLING

Type of bus transport	No. of Respondents	Percentage %
Public bus	46	38.3
Private bus	74	61.7
Total	120	100

Source: Primary Data

Interpretation

From the above table out of total respondents 61.7% of the respondents are using private bus transport while their travelling, rest of others 38.3% of them

using public transport while their travelling. Hence the Majority of the respondents **61.7%** are using private bus transport

2. LIKERT SCALE ANALYSIS

TABLE-2 SHOWING THE RESPONDENTS SATISFACTION LEVEL OF THEIR BUS SERVICE PROVIDERS ON THE BASIS OF TIME MANAGEMENT IN DEPARTURE OF BUS FROM BUS TERMINUS

Factors	No. of Respondents	Likert Scale	Total Score (fx)
Highly satisfied	10	5	50
Satisfied	31	4	124
Neutral	52	3	156
Dissatisfied	16	2	32
Highly dissatisfied	11	1	11
Total	120	15	373

Source: Primary Data

Interpretation

Likert scale value is 3.10. Hence the majority of the respondents are moderate in using the service

provided by the both public and private transport services.



3. RANK ANALYSIS

TABLE-3 SHOWING THE RESPONDENTS WITH RESPECT TO THE BASIS ON THEIR OPINION ABOUT BUS SERVICES**Public bus transport**

Factors	R1	R2	R3	R4	R5	Total	Final Rank
How safely bus drivers operate the bus	17(5) 85	35(4) 140	46(3) 138	14(2) 28	8(1) 8	399	1
How safely you using the bus	10(5) 50	35(4) 140	37(3) 111	37(2) 74	1(1) 1	376	3
Availability of sidewalk in bus terminus	9(5) 45	39(4) 156	38(3) 114	20(2) 40	14(1) 14	369	4
How comfortable/hospitality of the bus are to travel	12(5) 60	30(4) 120	48(3) 144	27(2) 54	3(1) 3	381	2
Courtesy of bus drivers	9(5) 45	39(4) 156	30(3) 90	26(2) 52	16(1) 16	359	5

Source: Primary Data

Interpretation

The above table reveals that, in public bus transport safety and the way of drivers operate the bus is ranked first (1), comfortable/hospitality is ranked second (2), how the respondents using the bus services safely is ranked third (3), Availability of sidewalk in bus terminus is ranked fourth (4), Courtesy of bus drivers is ranked fifth (5).

14. Majority 39.2% of the respondents are daily using the services provided by public and private bus transports.
15. Majority 23.3% of the respondents are choosing for the reason of all other factors provided by the both public and private bus transports.
16. Majority 23.3% of the respondents are choosing for the reason of all other factors provided by the both public and private bus transports.

IX. FINDINGS

SIMPLE PERCENTAGE ANALYSIS

1. 83.3% are in the age group of below
2. 50.8% of the respondents are female
3. 85.8% of the sample respondents are unmarried
4. majority of the respondents earn below Rs.250000 per year
5. 53.3% of the respondents are residing in centre of city
6. Majority 61.7% of the respondents are using private bus transport
7. Majority 40% of the respondents are using for education purpose.
8. Majority 44.2% of the respondents are consider for all the above services provided by bus transport.
9. Most 44.2% of the respondents are said all the time in peak hours of travel.
10. Majority 34.2% of the respondents are facing bus schedule time problems.
11. Majority 63.3% of the respondents are feel comfortable while travelling in private bus transport.
12. Majority 42.5% of the respondents are using bus transport more than 3 years.
13. Majority 37.5% of the respondents are expecting cleanliness services.

LIKERT SCALE ANALYSIS

1. Likert scale values are greater than the mid value. Hence the majority of the respondents are satisfied in using the services provided by the both public and private bus transports.
2. Likert scale values are greater than mid value. Hence the majority of the respondents are moderate in all those services provided by the both bus transport services.
3. Likert scale values are greater than mid value. Hence the majority of the respondents are moderate in using the service provided by the both public and private transport services.
4. Likert scale values are greater than mid value. The majority of the respondents are neutrally using the bus services.
5. Likert scale values are more than mid value. Hence the majority of the respondents are satisfied in using the both public and private bus transport service providers.



RANK ANALYSIS

1. It resulted that safety and the way of drivers operate the bus is ranked first in **public bus transport** from the respondents.
2. It resulted that safety and the way of drivers operate the bus is ranked first in **private bus transport** from the respondents.
3. Cleanliness is ranked first, from the **opinion about the influencing factors to the bus services**

X. RECOMMENDATION

It is advisable for both bus transport to improve their service efficiency, and most of the respondents opinion is in public/TNSTC enhance their quality of services, condition of transport, bus fare and major problem in bus schedule, so they should try to implement these factors for get the satisfaction level among their passengers. The above review reveals the most of the respondents are choosing the private transport for the reason of courtesy of bus drivers, like behavior and way of driving and punctuality, so the opponent bus transport should aware about these factors, they can get the satisfaction among the public and passengers. Most of the customers are moderately satisfied about the performance of their service provider, so they should try to add some major factors which they needed and some features and facilities towards their services.

XI. CONCLUSION

The present study reveals that the majority of the respondents prefer to use private bus transport for the reasons of maintenance, reliability, cleanliness, seating capacity, reasonable hike in bus fare, convenience. These factors will enable the bus transport sectors to increase their quality and the level of satisfaction among the passengers at different segment. The results of this study the assumption that most of the respondents choose private bus transport for the reason of cleanliness, bus fare, speed of transport, time and efficient services and bus schedule. So the other service providers shall pay the attention on these factors to make their service is more successful and satisfying the customers.

REFERENCE

JOURNALS

1. GAJENDRAN.A - 2012, "A study on bus passenger perception and level of satisfaction with special reference to bus transport industries in tamilnadu", *International journal research journal of social science and management, vol-1, issue-9, pp.no129-142.*
2. NAGASUBRAMANIYAN .G & JAGADESH. B - 2017, " Assessment of service quality public bus, transport system Thiruchirapalli" *International journal of research applied science and engineering and technology, volume-5, issue -5, pp.no 2120-2124.*
3. XUAN PHUONG NGUYEN - 2019, " The bus transportation issue and people satisfaction with public transport in HO CHI MINH city ", *Journal of mechanical engineering research and developments, vol-42, issue-1,pp-10-16.*

WEB REFERENCE

4. http://www.sntp.net/psychology_definition.htm
5. www.tnstc.in, www.setc.com



A STUDY ON CUSTOMER SATISFACTION TOWARDS TITAN WATCHES WITH SPECIAL REFERENCE TO COIMBATORE CITY

***Dr. S. Suguna**

*¹Associate Professor, Department of Commerce with Professional Accounting,
Dr.N.G.P. Arts and Science College, Coimbatore 641 048, Tamil Nadu.*

**** Gnana Sekar. A**

*² Student of III B.Com (PA), Department of Commerce with Professional Accounting,
Dr.N.G.P. Arts and Science College, Coimbatore 641 048, Tamil Nadu.*

ABSTRACT

The project entitled “A study on customer satisfaction towards titan watches with special reference to Coimbatore city is carried out with an objective to determine the consumer preference and satisfaction. The primary objective of the study is to find out the consumer preference and satisfaction towards titan watches with special reference to Coimbatore city. A customer is one who buys any goods and services by paying its price for consumption. No business activities move in the country without the presence of consumers. The usage of new tools and techniques brought about revolutionary changes in the production of goods. “Customer is king” in marketing. In sales, commerce and economics a customer is the recipient of a good, service, product or an idea- obtained from a seller, vendor, or supplier via a financial transaction or exchange for money or some other valuable consideration. In a recent times, a major brand repositioning exercise has been planned by Titan Industries Ltd, in order to provide more to its customers. The watch and clock industry has been a market with great longevity throughout the years, as these times pieces have always been needed and in demand by customers. Several Indian watch manufacturers have global ambition in today’s globalized, modernized, and economically stable and strong country. The present study consists of reviewing the customer satisfaction of Titan watches. After liberalization of Indian economy in 1992 many international players have entered the Indian watch market posing as competitive threat to the Indian companies. For the purpose of the study, a convenient sampling survey was conducted among 120 respondents in Coimbatore city with the help of e-questionnaire. The tools used for this study are simple percentage analysis, Likert scale analysis, and Rank analysis.

KEYWORDS-Quality and Service of Titan, Customer Satisfaction, Simple percentage analysis, Likert scale analysis, Rank analysis.

I. INTRODUCTION

ABOUT TITAN

Our Vision: To be a world-class, innovative and progressive organization and to build India’s most desirable brands.

Our Mission: To create wealth for all our stakeholders by building highly successful Businesses based on a customer-centric approach, and to contribute to the community

The house of Tata was started by Jamshedji Tata in 1868 as a textile trading company. Tata as a business group has created wealth for the

nation. Tata has pioneered every large business in India and the group is often called as the “First Citizen of Corporate India.” Some of the



businesses pioneered by the group are: India's steel industry, first power plant, brought insurance to India, started first chain of luxury. Helping the brand increase sales, increase price premium, sell the more expensive watches, improve image, keep competition at bay and keep the brand name. Consumers and professionals alike have resonated equally to Titan's successful efforts in bringing international Standards to India. The most admired Consumer Durable brand. Titan today sells in the UK, Spain. Portugal. Greece. Singapore, Dubai, Malaysia, Oman, Philippines and many more countries. The combination of Contemporary Style, Great Quality and Great Prices. With over 100 million satisfied consumers and a track record of breaking the rules, Team Titan faces the 21st Century with a mix of passion, to make a trend, excitement and energy. The world's largest wrist watch manufacturer and India's leading producer of watches under the Titan and its sub-brands. It is subsidiary of the Tata Groups. Titan is one of the leading brand in the India.

II. STATEMENT OF THE PROBLEM

Here the necessity for selecting a problem in a marketing research is defined.

However the following questions may arise regarding customer satisfaction.

- The problem stated as "to what extent the customers are satisfied with the price and quality and also which factors creating more influence on the customers.
- To find the current preference and satisfaction about the watches rooted in the minds of the customers which could be useful in formulating the strategies in future operations of the company.
- The problem stated as which factor will be enhance to buy their products and which will help to improve the purchases among the customers. And find out the various problem faced by the customers while purchasing.

III. OBJECTIVES OF THE STUDY

The study is undertaken with the following objectives.

- To know about the current scenario of titan watches.
- To analyse the statistical responded opinion.
- To find the satisfaction and brand preference among customers.
- To identify the kinds of recommendations made towards the titan watches. And find the suitable measures to be taken by the Titan Company to further improve its satisfaction,

preference and loyalty among its customers.

IV. RESEARCH METHODOLOGY SOURCE OF DATA

- Primary data is used in the study. It is original data for the purpose of collection of primary data, e-questionnaire were filled by the respondents. The e-questionnaire comprises of close ended.
- The secondary data was collected from various possible records like books, magazines, periodicals and websites.

RESAERCH DESIGN

- **Sampling technique**
The sampling technique used in this study was convenient sampling.
- **Sample size**
The study was conducted with a sample size of 120 respondents.
- **Area of study**
The study was undertaken in Coimbatore city.

V. RESEARCH TOOLS FOR ANALYSIS

- Simple percentage method
- Likert scale analysis
- Rank analysis

LIMITATIONS

- Sample size restricted to 120 customers.
- The study was focused only in the Coimbatore city.
- Findings of the study purely depends upon the responses given by respondents.

VI. REVIEW OF LITERATURE

Arati Birder (2014), in their studied titled "A study on market study of sonata and Casio watches" its finding of the study of market performance of these two companies brand watches. They conducted that the end of advertisement, websites, social media's, newspaper and journal, etc., and these are the presented and their position in the market demands. In this study of profile in various findings and objectives says, the socio- economic cost based. The chi-square of respondents, to segregates the level of opinion there are the high level, medium level and low level performance.

Praveen Kumar. L (2015), conducted the "study on customer satisfaction towards the fast-the study say that company should ensure the availability of all models and outlets of fast-track consumers are satisfied birder loyal customers by providing those



special offers and different features. Finally, the study conducted to know about the satisfaction level of

customers and their purchasing behavior while purchasing. Concluded by saying that the survey of the customers has revealed the like and dislikes and tastes regarding watches.

Keller, (2017), this study conducted the Brand awareness is the first and prerequisite dimension of the entire brand knowledge system in consumers' minds, reflecting their ability to identify the brand under different conditions: the likelihood that a brand name will come to mind and the ease with which it does so. The purpose of the study also includes to the awareness level of titan quartz watch from the public.

VII. DATA ANALYSIS AND INTERPRETATION

The chapter deals with analysis and interpretation of the study "A Study on Customer Satisfaction towards TITAN WATCHES With Special Reference to Coimbatore City". Based on the data collected, the collected data have been analyzed using the following statistical tools.

- Simple Percentage Analysis
- Likert Scale Analysis

1. SIMPLE PERCENTAGE ANALYSIS

The percentage analysis is mainly used to specify the number of respondents in this sample falling in each category. Further, it is also used as a standard for comparison purpose.

PREFERENCE OF THE RESPONDENTS

Preference	No of Respondents	Percentage %
Attractive design	24	20
Reasonable price	25	20.8
Brand image	36	30
Unique collections	13	10.8
All the above	22	18.4
Total	120	100

(Source: Primary data)

Interpretation

The above table depicts that, out of 120 respondents 30% of the respondents prefer titan watches for its brand image, 20.8% of the respondents prefer titan watches for its reasonable price, 20% of the respondents prefer titan watches for its attractive design, 18.4% of the respondents prefer titan watches for the above factors which is shows in the table and 10.8% of the respondents prefer titan watches for its unique collections.

It is concluded that, most (30%) of the respondents prefer titan watches for its **BRAND IMAGE**

2. LIKERT SCALE ANALYSIS

A Likert scale is a method of measuring attitudes, ordinal scale of responses to a question or statement, ordered in hierarchical sequence from strongly negative to strongly positive.

SATISFACTION LEVEL OF RESPONDENTS TOWARDS TITAN WATCHES ON THE BASIS OF AFFORDABILITY OF PRICE

Satisfaction level	No. of Respondents	Likert scale	Total score
Highly satisfied	29	5	145
Satisfied	37	4	148
Neutral	30	3	90
Dissatisfied	24	2	48
Highly dissatisfied	0	1	0
Total	120	15	431

(Source: primary data)

Interpretation:

Likert scale value is 3.5 is greater than mid value (3). Hence the majority of the respondents are satisfied in price.

FINDINGS

SIMPLE PERCENTAGE ANALYSIS

- Majority 47.5% of the respondents are in the age group of 21-30 years



- Majority 67.5 % of the respondents are male.
- Majority 77.5% of the sample respondents are unmarried
- Majority 73.5% of the respondents have UG level of education
- Majority 59% of the respondents are students.
- Majority 46.5% of the respondents earn monthly income of below Rs.10000.
- Majority 37% of the respondents have 2 watches.
- Majority 87.5% of the respondents have the awareness of the titan watches
- Majority 50% of the respondents are aware of sonata sub-brand of titan watches.
- Majority 32.5% of the respondents use the titan watches for a period of 6 months to 1 year.
- Most 47.5% of the respondents spend Rs. 1000 up to Rs.2500 for buying titan watches.
- Majority 30.8% of the respondents are influenced by the friends and relatives and also in advertisements.
- Most 30% of the respondents prefer titan watches for its Brand image.
- Majority 31.7% of the respondents bought both leather and chain strap models.
- Majority 42.5% of the respondents are purchasing titan watches casually.
- Majority 39.2% respondents are influenced to buy the titan watches for quality.
- Majority 47.5% of the respondents are frequently visiting the men's category.
- Majority 65% of the respondents are effectively inspired by the new advertisement
- Majority 47% of the respondents opinion is provide festival offers during on purchases

LIKERT SCALE ANALYSIS

- ▲ The majority of the respondents are satisfied to buying and using titan watches.
- ▲ The most of the respondents are moderate to use the titan watches for its attractive design.
- ▲ Most of the respondents are satisfied to use the titan watches for the reason of comfortability.
- ▲ Respondents are highly satisfied to use the titan watches for warranty.
- ▲ Most of the respondents are satisfied to prefer the watches for its popular image

VIII. SUGGESTIONS

From the findings of the study the following suggestions were made

1. Some more attractive festival offers and gifts may be given on purchases.
2. To increase the variety of design of the

watches

3. Respondents feels that the price of titan and its sub watches is too high.
4. They may anticipate a reduction in price, which can be affordable to the common class of people.
5. One service mechanic must be provided by the company at every showroom to ensure consumer goods and services advice.

IX. CONCLUSION

The customer of titan brand wrist watches are highly satisfied. Customers having pride in owning and wearing the most sophisticated, highly reliable and superior performance watch. Titan brand watches are in great demand not only in India but also abroad. The most featured and advanced model of watches entered in to the market world but still, the titan watches has been demand in market of world wide. Though there is increasing demand for all varieties of titan watches, but a few suggestions given by the respondents is to be considered by the manufacturer of titan. The company has to put its efforts in improving the factors, introduce new collection with changing outlook to appeal and attract potential customers for its products.

REFERENCE

1. Arati Birder (2014) "**Market study of Fast-track and Casio watches**" *International Journal for Multidisciplinary Research*, vol.2, issue 2, 390-391.
2. Praveen Kumar .L (2015) "**A study on Customer Satisfaction of Wrist Watches in Mysore**". *A Means – End model and synthesis of evidence, International Journal of Advance Research in Computer Science and Management Studies*. Issue 32(3), 2-22.
3. Keller, (2017) *Marketing Management 10th edition, Research Methodology and Techniques*. Vol.4 (11), Issue 3, 33-38

WEB REFERENCES

1. <http://fastrackprofile.com>.
2. www.wristwatchprofile.in



A STUDY ON PASSENGERS SATISFACTION TOWARDS SOUTHERN RAILWAY SERVICES WITH SPECIAL REFERENCE TO COIMBATORE JUNCTION

Dr. N. Ramya

*Assistant Professor, Department of commerce with professional Accounting,
Dr. N.G.P. Arts and Science College, Coimbatore*

Madhanraj. K

*III B.Com (PA), Department of commerce with professional Accounting,
Dr. N.G.P. Arts and Science College, Coimbatore*

ABSTRACT

This study is mainly focused on the passenger's satisfaction towards Southern Railways with special reference to Coimbatore Junction. In today's competitive market scenario, organizations increasingly understand the importance of building and effectively managing the relationship with its customers. Southern Railways is the one of the largest rail transports in the world. Southern railways system operated by the Ministry of Railways. It manages the fourth largest railway network in the world by size, with a route length of 67,368- kilometres (41,861mi) as of March 2017. The contribution of this study is the identification of factors that determine passenger satisfaction with the quality of service provided by the southern railways. Service quality has been viewed as a determinant of passenger satisfaction

KEYWORDS : *Passengers perception and satisfaction*

INTRODUCTION

Recent years have seen a tremendous growth in the service sector. Southern railway is the state-owned railway company of India. Southern railways had, until very recently, a monopoly on the country's rail transport. It is the one of the largest and busiest rail transports in the world, transporting just over six billion passengers and almost 750 million tons of freight annually. India's transport industry has been organized with a mixed pattern of public and private sector ownership.

SCOPE OF THE STUDY

The study is mainly focused on the satisfaction level of the passengers from the services being offered by southern railways. Every aspects pertaining to railway service like ticket availability, quality of travel, staff behaviour, safety, timing and other are required to explore in a detailed manner. Hence the selected

STATEMENT OF THE PROBLEM

Southern railways provide many services to the passengers who travel in the train. The following questions were raised in the mind of researcher

1. What are the services qualities offered by the southern railways services?
2. What is the level of satisfaction of passengers towards the service provided by the Southern railway services?

sample population is to analyse the problems faced by the passengers is being chosen to know the service quality provided by the Southern railway services.

OBJECTIVIES:

- ▶ To determine the extent of relationship and the level of awareness of passengers towards southern railways offered to the passengers.



- ▶ To study the problems faced by the passengers in utilizing the service qualities provided by the Southern railway services.
- ▶ To study the level of Passengers satisfaction and the services offered by the Southern railway services

LIMITATIONS OF THE STUDY

- ❖ The study is mainly based on the information given by the sample respondents, and the factors given by them are subject to their beliefs and attitude.
- ❖ The suggestions are not constant because the mind-set of the respondent may be changed.
- ❖ Since the data collected from the respondents are subjected to their opinion and perception. The study mainly covered the southern railway Coimbatore junction, so it may be vary in other junction.
- ❖ The time of the study is limited.
- ❖ The research area is also limited.
- ❖ The number of respondents was limited to 120.

REVIEW OF LITERATURE

D Anbupriya, Dr. S Subadra (2016). In their study, an Indian railway is the life line of the nation. The system never rests; it has been up and working perpetually for the last several decades. The objective of the study is to analysis the travel factors influencing the passengers of Southern Railways. The study was conducted using non-probability sampling techniques and the convenience sampling method was adopted because the sampling size was unknown. The main purpose of the study is to know the satisfaction level of the passengers of the passengers on the services provided by the Southern Railways.

FORMULA:

$$\text{Percentage Analysis} = \frac{\text{No. of Respondents}}{\text{Total No. of Respondents}} * 100$$

TABLE 1

TABLE SHOWING GENDER OF THE RESPONDENTS

S.No	Categories	No. of Respondents	Percentage (%)
1	Male	68	57
2	Female	52	43
	Total	120	100

INTERPRETATION

The table shows that 57% of the respondents are male and 43% of respondents are female.

Mahima Johnson (2019). In their study, The Southern Railway headquarters at Chennai, Tamil Nadu is one of the earliest zones of Indian Railways. The objective of their study is to explore the problem faced by the daily railway passengers. Convenience random sampling is used in their study and the research is based on the survey method. Based on their present study, the following suggestion had made to improve the services of the Indian Railways.

RESEARCH METHODOLOGY

The research design is the procedure used for collecting the data and analysing it for arriving at conclusion for attaining the objectives of the study. The design adopted for this study is descriptive in nature, the study is attempted to find the level of satisfaction of the passengers and the service quality offered to them by the Southern railways. Hence it is a descriptive research work.

DATA ANALYSIS & INTERPRETATION

The collected data were grouped, edited, tabulated in a master table and analysed using the following statistical tools.

- Percentage Analysis
- Ranking Analysis
- Likert Scale Analysis

PERCENTAGE ANALYSIS:

Simple percentage analysis is carried out for most of all questions gives in questionnaire. This analysis describes the classification of respondents falling in each category. The percentage analysis is used mainly for standardization and comparisons are in support with the analysis.

INFERENCE:

Majority 57% of the respondents are male.



RANK ANALYSIS:

Ranking is a relationship between a set of items such that, for any two items, the first is either ‘ranked higher than’, ‘ranked lower than’ or ‘ranked equal to’ the second. In this study, ranking analysis is applied for the

responses collected which are ranked from (5 to 1) towards various sources of information by the respondents and also for the satisfaction and the problems faced by the respondents and the service quality of the Southern Railways with reference to the Coimbatore City.

TABLE 2
TABLE SHOWING DISTRIBUTION OF RANKING FOR PASSENGERS SATISFACTION TOWARDS SOUTHERN RAILWAYS WITH SPECIAL REFERENCE TO COIMBATORE CITY.

S. No	Particulars	1	2	3	4	5	TOTAL	RANK
1	Sanitation	22(5)	24(4)	36(3)	25(2)	13(1)	377	3
2	Convenience	20(5)	31(4)	33(3)	29(2)	7(1)	388	2
3	Canteen	36(5)	28(4)	21(3)	21(2)	14(1)	441	1
4	Easy to carry more luggage's	29(5)	29(4)	12(3)	24(2)	26(1)	372	4
5	Safety	13(5)	8(4)	18(3)	21(2)	60(1)	253	5

INTERPRPETATION

From the table, it is understood that Canteen is ranked 1, convenience is ranked 2, Sanitation is ranked 3, easy to carry more luggage's is ranked 4, Safety is ranked 5.

INFERENCE

Canteen have been ranked 1st by the passengers for the level of satisfaction towards southern railways in Coimbatore city.

LIKERT SCALE ANALYSES:

Likert scale is a common ratings format for surveys. Respondents rank quality from high to low or best to worst using five or seven levels. Likert items are used to measure respondents' attitudes to a particular question or statement. To analyze the data it is usually coded as follows:

- 5 = Strongly Agree
- 4 = Agree
- 3 = Neutral
- 2 = Disagree
- 1 = Strongly Disagree

FORMULA:

$$\text{Likert scale} = \frac{\sum fx}{\text{Total number of respondents}}$$

While,
 f = Number of respondents
 x = Likert scale value
 $\sum (fx) = \text{Total score}$

Mid value:

Mid value indicates the middle most value of likert scale



TABLE 4.3.1
TABLE SHOWING PASSENGERS SATISFACTION TOWARDS SOUTHERN RAILWAY SERVICES WITH SPECIAL REFERENCE TO COIMBATORE JUNCTION.

S.No	Factors		5	4	3	2	1	TOTAL	Likert Scale
	Likert Scale value (x)								
1	Trust worthy	F	55	44	13	6	2	120	0.24
		Fx	275	176	39	12	2	504	
2	Passengers Convenience	F	5	39	36	38	2	120	0.33
		Fx	25	156	108	76	2	367	
3	Punctuality Of trains	F	34	24	31	22	9	120	0.29
		Fx	170	96	93	44	9	412	
4	Employees responses to passengers	F	20	27	20	22	31	120	0.35
		Fx	100	108	60	44	31	343	
5	Physical Facilities	F	19	26	28	24	23	120	0.34
		Fx	95	104	84	48	23	354	

INTERPRETATION

The likert scale value is less than the mid value (3), thus the respondents are not satisfied with the factors.

INFERENCE

The respondents are not satisfied with the factors.

FINDINGS AND SUGGESTIONS
FINDINGS FROM PERCENTAGE ANALYSIS

- 40% of the respondents are in the group of 18 to 30 years.
- 57% of the respondents are in male.
- 51% respondents are unmarried.
- 50% of the respondents are at UG level
- 46% of respondents are doing other occupation
- 45% of the respondents are unemployed.
- 65% of the respondent's family having annual income of Rs. 2, 50,000.
- 89% of the respondents are prefer to order food over the mobile app.
- 43% of the respondents are prefer for the purpose of journey for personal.
- 60% of respondents are using the passenger train.
- 57% of respondents are using the E-Ticketing method for getting tickets by the respondents.
- 37% of respondents are travelling with friends and relatives.

- 35% of the respondents are monthly make a journey by train
- 48% of the respondents are season ticket holding.
- 39% of respondents expect comfort from the southern railways.
- 51% of the respondents are travelling passenger.

FINDINGS FROM RANK ANALYSIS

- Canteen have been ranked 1st by the passengers for the level of satisfaction towards southern railways in Coimbatore city.

FINDINGS FROM LIKERT SCALE ANALYSIS

- The respondents are not satisfied with the factors.

SUGGESTIONS

- The respondents suggested for the improvement in the sanitation facilities.
- It is found that majority of the respondents are not satisfied with the services provided by the Indian railways.
- Good amenities, quality food and medical aids should be provided to enlarge the number of long distance travelled passengers.
- Delay in railways and cleanliness can be solved.
- Focus on vital service quality factors like facilities, hygiene and safety-security, which is



considered as important factors to determine the satisfaction of the customers. .

- By installing more reservation counters to help the passengers to reserve their tickets in short period of time for better customer satisfaction can be achieved.

CONCLUSION

Southern Railways provides the most important mode of public transport in India. Railways have played a significant role in development and growth of India. This is the most commonly used and cost effective long distance transport system of the country. The empirical study is really a contribution to identify the factors that determine passenger satisfaction in rail with quality and services provided by the southern railways. Railways try to improve the core areas and deliver quality of services to the passengers. Accordingly, the research give some insights to develop and improve the quality of services to satisfy the passengers in railways. The satisfaction is the need of the passengers is important to compete with other mode of transport. On the basis of this study some suggestions has been made. If the suggestive measurements have been consider by the Southern railways, it is hope that the southern railways will shine and bright magnificent to our country in the near future.

REFERENCES

1. D Anbupriya, Dr. S Subadra (2016), "Satisfaction of passengers towards service quality of Southern railways: a Study"; *International journal of Commerce and Management Research* Volume2; Issue 11; November 2016; PP. No. 80-85.
2. Mahima Johnson (2019). "A Study on passenger's Satisfaction towards Railway Services in Kerala "; *International Journal Of Business and Management Inventions (IJBMI)* Volume 8; Issue 03; March 2019. PP. NO. 19-23.

JOURNALS

1. *International Journal of Advance Research in Management and Social science*
2. *IOSR Journal of Economics and Finance.*
3. *International Journal of Business and Management Invention.*
4. *International Journal of Multidisciplinary Research and Development.*
5. *International Journal of Development Research.*
6. *International Journal Of Management and Social Science Research Review.*
7. *IOSR Journal of Business and Management.*
8. *International Journal of Commerce and Management Research.*
9. *International Journal of Applied Research.*



A STUDY ON CONSUMERS' SATISFACTION TOWARDS AMAZON ONLINE SHOPPING WITH SPECIAL REFERENCE TO COIMBATORE CITY

Anusuya.A

*Student of III B.com (PA), Department of Commerce with professional Accounting,
Dr.N.G.P Arts and Science College (Autonomous), Coimbatore*

Dr. R. Mayilsamy

*Assistant Professor, Department of Commerce with professional Accounting,
Dr.N.G.P Arts and Science College (Autonomous), Coimbatore*

ABSTRACT

Online shopping is the new trends in the marketing system. In India, it used to refer the computer/ mobile based shopping. Over the past few years, online shopping has increased the percentage of online buyer's in India. The discussion of this study mainly focuses on Customer Satisfaction towards Amazon Online shopping in Coimbatore district. In this study based on some objectives; the customers satisfaction towards Amazon in Coimbatore district, the benefits available on online buying through Amazon in addition to analyze the problem faced by the customers of Amazon. The attitude and preference of customers on purchasing products through online are affected by various factors. The researcher has used both primary and secondary data. The researcher has find out "Today internet is the user friendly communication medium and its awareness and usage level is progressively increasing in all segments of the society".

KEYWORDS: Online Shopping, Amazon and Customer Satisfaction.

INTRODUCTION

Web based shopping is the way toward looking into and obtaining items or administrations over the web. The most punctual online stores started a new business in 1992, and web based retailing assumed control over a noteworthy portion of the retail advertise during the main decade of the twenty-first century, as responsibility for PCs expanded and set up retailers started to offer their items over the Internet. Electronic trade is utilized for both business-to-business (B2B) and business-to-customer (B2C) exchanges. Purchasing items from an online shop, or virtual store is like obtaining from a mail request inventory. Online stores depict items available to be purchased with content, photographs, and sight and sound records. Normally the client chooses things to be recorded on a request from known as a "shopping basket," and pays with a Mastercard or some type of electronic instalment.

STATEMENT OF THE PROBLEM

We face many millions of problems when we entered into the world of online shopping. Amazon also one of the online shopping application site that nowadays reached to millions of people everywhere. There are some problems that customer are deal with like:

- Delay in delivery of goods and products is also one of the problems that affect the serenity of the customer
- Payment method

SCOPE OF THE STUDY

- This research work will covered Amazon and also deals with the customer which are regulars used to shopping online
- The study also covered the quality of the service and how they input on the customer complacency and for instant it come across with what factor that are accommodate and enhance the satisfaction feeling of the customer on Amazon.



OBJECTIVES OF THE STUDY

- To assess the factors that influencing Amazon online shopping.
- To explore the satisfaction level of customers towards the online shopping.
- To analysis the different payment and delivery systems preferred by the customers.
- To identify the problems faced by the customers in the online shopping.

RESEARCH METHODOLOGY

RESEARCH DESIGN:

Research design is defined as a framework of methods and techniques chosen by a researcher to combine various components of research in a reasonably logical manner so that the research problem is efficiently handled. It provides insights about “how” to conduct research using a particular methodology. Every researcher has a list of research questions which need to be assessed- this can be done with research design.

DESCRIPTIVE RESEARCH:

Descriptive research is “aimed at casting light on current issues or problems through a process of data collection that enables them to describe the situation more completely than was possible without employing this method”. Descriptive research is involves collecting data in order to answer research questions concern.

COLLECTION OF DATA

PRIMARY DATA: The primary data have been collected directly from the customers through well-structure questionnaire.

SECONDARY DATA: The secondary data have been collected from various possible records like books, magazines, periodicals and web sites.

SAMPLING SIZE AND TECHNIQUE:

➤ SIZE OF THE SAMPLE

In the present study, 120 respondents were selected as size of the sample.

➤ SAMPLE DESIGN

The sample technique used in this study is convenient sampling method. This is also called as method of chance election.

AREA OF THE STUDY

The study is conducted only in Coimbatore city.

STATISTICAL TOOLS USED:

To analyse and interpret collected data the following statistical tools were used,

- Simple percentage Method
- Likert’s scaling technique
- Ranking analysis

LIMITATIONS OF THE STUDY

- The response to the poll to a great extent relies on the mind arrangement of the respondents.
- Respondent's assessment may not be liberated from bias.
- The example size was restricted to 120 respondents

REVIEW OF LITERATURE

Muruganatham, et al. (2017), Examined the satisfaction towards online shopping. Online shopping is the process whereby consumers directly buy goods, services etc., from a seller interactively in real time without an intermediary service over the internet. The main objective of the study is to identify the problem in the online shopping. The customer face major problems on theft of credit card information and lack of security on online payments. Implementing precautionary step to solve these problems shall create consumers confidently on online shopping. They can conclude a study consumers are looking for trust, security and wider choice throughout online shopping.

Shanthi and Destikannaiah (2015), This study establishes the internet marketing is conceptly different from other marketing channels. Today business internet marketing is the fastest growing segment of online commerce the objectives of the study is to know the type of product purchased by consumers through online shopping. The study reveals that mostly the youngsters are attached to the online shopping and hence the elder people don't use online shopping much as compared to the younger ones. The study also reveals that majority of the respondent buys clothes from Flipkart.com which is thus one of the leading online shopping websites in India.

Aminul Islam (2011), Consumer satisfaction on online shopping in malaysia justified that, the factors that are affecting consumers intention and satisfaction to stop online. To stop on internet becomes an alternative for consumers since it is more comfortable than conventional shopping which usually attributed with anxious, crowded, traffic jam, limited time, parking space and etc.,

ANALYSIS AND INTERPRETATION

Analysis and interpretation is essential for usefulness and utility of resources finding Analysis of data and interpretation in a general way involves a number of closely related operations, which are performed with a purpose of summarizing the collected data, organizing these in such manner that they answer the research question. Researcher can better be appreciated only through the interpretations why this finding are, what can make others to understand the real significance his/her research finding. The Tools used for analysis are



- 4.1 Simple percentage Method
- 4.2 Likert's scaling technique value Analysis
- 4.3 Ranking Analysis

SIMPLE PERCENTAGE ANALYSIS

This analysis is carried out for the most of the question gives in questionnaires. This analysis described the classification of the respondents failing each category. The percentage analysis is used mainly for the standardization and comparisons are in support with the analysis

FORMULA

$$\text{Percentage} = \frac{\text{Number of Respondents}}{\text{Total No. of Respondents}} \times 100$$

TABLE 1**TABLE SHOWING GENDER OF THE RESPONDENTS**

S.NO	GENDER	NO.OF. RESPONDENTS	PERCENTAGE (%)
1	Male	66	55
2	Female	54	45
	TOTAL	120	100

*(Source: Primary Data)***INTERPRETATION**

In the above table 1 shows out of total 120 respondents, 55% of the respondents are male and 45% of the respondents are female.

Majority (55%) of the respondents are Female.

LIKERT SCALE ANALYSIS

A Likert scale analysis is a method of measuring attitudes. Ordinary scale to response to a question or statement, order in hierarchical sequence from strongly negative to strongly positive, used mainly in behavioral science and psychiatry. In Likert's method a person's attitude is measured by combining (additional or average) their responses across all items.

FORMULA

$$\text{Likert scale} = \frac{\sum FX}{\text{Total number of respondents}}$$

Where;

F= Number of respondents

X= Likert scale value

FX= Total score

MID VALUE:

Mid-value indicates the middle most value of the Likert Scale.

TABLE 2**TABLE SHOWING THE FACTORS INFLUENCED TOWARDS WAITING FOR RECEIVING THE PRODUCT**

S.NO	FACTORS	NO.OF. RESPONDENTS (F)	LIKERT VALUE (X)	TOTAL SCORE (FX)
1	Very good	31	3	93
2	Good	74	2	148
3	Poor	15	1	15
	TOTAL	120		256

(Source: primary data)

$$\text{LIKERT SCALE VALUE} = \frac{\sum FX}{\text{No.of. Respondents}}$$

$$= \frac{256}{120}$$

$$= 2.13$$



INTERPRETATION

Likert scale value is 2.13, so the customers are good with waiting for receiving of product.

RANKING ANALYSIS

A rank analysis is any of several statistics that measure an ordinal association, the relationship between ranking of different ordinal variables or different ranking of the same variables, where a "ranking" is the assignment of the tables "first",

"second", "third", etc., To different observation of a particular variable. A rank analysis measure of similarity between two rankings, and can be used to assess the significance of the relation between them. It is not necessarily a total order of object because two different them. It is not necessarily a total order of object because two different objects can have the same ranking. The ranking themselves are totally ordered.

TABLE 3
TABLE SHOWING THE FACTORS INFLUENCING THE ONLINE SHOPPING

S NO	PROBLEMS	RANK 1	RANK 2	RANK 3	RANK 4	RANK 5	TOTAL SCORE	FINAL RANK
1	Price	44(5)	50(4)	16(3)	4(2)	6(1)	482	I
2	Quality	26(5)	66(4)	15(3)	8(2)	5(1)	460	III
3	After Sales Service	27(5)	45(4)	38(3)	7(2)	3(1)	446	V
4	Offers And Discount	29(5)	54(4)	25(3)	11(2)	1	459	IV
5	Advertisement	35(5)	51(4)	21(3)	7(2)	6(1)	462	II

INTERPRETATION

Table 3, its understood that the sample respondents are given first rank for Pricing, they are given second rank for the advertisement, they are given the third rank for Quality of products, they are given fourth rank for Offer and discount on products, and they are given the fifth rank for after sales service.

In this study the majority of respondents are given the first rank for the pricing of products.

FINDINGS

SIMPLE PERCENTAGE ANALYSIS

- Majority, 55% of the respondents are Female.
- Majority, 75% of the respondents are below 15 years-25 years.
- Majority, 77.5% of the respondents are unmarried.
- Majority, 65.8% of the respondents are graduation.
- Majority, 48.5% of the respondents are students.
- Majority, 66.7% of the respondents are 4-5 members.
- Majority, 65.8% of the respondents are nuclear family.
- Majority, 44.2% of the respondent's monthly income are below Rs.20, 000.
- Majority, 45% of the respondents known by advertisements.
- Majority, 38.3% of the respondents using by more than 1 year.

- Majority, 32.5% of the respondents are preferred for good quality.
- Majority, 72.5% of the respondents are using cash on delivery.
- Majority, 62.5% of the respondents over all opinion are good.

LIKERT'S SCALING TECHNIQUE

- Likert scale value is 2.13, so the customers are good with waiting for receiving of products.
- Likert scale value is 1.97, so the customers are poor with credit card transaction.
- Likert scale value is 1.92, so the customers are poor with risk of identity theft.
- Likert scale value is 2.1 so, the customers are good with difficulty in return products or items.
- Likert scale value is 2.10, so the customers are good with complex compared to traditional shopping.
- Likert scale value is 2.14, so the customers are good with risk of losing privacy.
- Likert scale value is 3.21, so the customers are satisfied with price.
- Likert scale value is 3.1, so the customers are satisfied with speed of delivery.
- Likert scale value is 3.05, so the customer are satisfied with loyalty of this online.
- Likert scale value is 3.26, so the customers are satisfied with variety of products.
- Likert scale value is 3.10, so the customers are satisfied with customer support.



- Likert scale value is 3.04, so the customers are satisfied with quality of delivered products
- Likert scale value is 3.13, so the customers are satisfied with recurring purchase in same store.
- Likert scale value is 3.11, so the customers are satisfied with offers and discounts.
- Likert scale value is 3.10, so the customers are satisfied with advertisements.

RANKING ANALYSIS

➤ In this study the majority of respondents are given the first rank for the pricing of products.

SUGGESTIONS

- Online shopping portal should be made as user friendly for the end user (customers).
- Sometimes consumers facing delivery issues due to logistic complaints, hence the portal should take appropriate measures to overcome the logistics problem.
- One of the major drawbacks that the respondents have felt is no proper returning policy to the product. After getting opinion from the respondent if the above said problem occurs, then they should be guided in a proper way to return the product. This will create a good website reputation and repurchasing power of the respondents.
- The respondents face major problems on theft of credit card information and lack of security on online payments, implementing precautions steps to solve these problems shall create consumer confidence on online shopping.
- The reliability and responsiveness of the delivery system is the key success factor for any online business and this will attract the customers repurchasing intention.

CONCLUSION

This study concluded online shopping is a highly best one, when compared to other shopping. The study about the various aspects of customer satisfaction on amazon online shopping is satisfied with price, speed of delivery, loyalty or this online, variety of product, customer support, quality of delivery products, recurring purchase in same store, offers & discounts and advertisements. If the suggestion given by the customers implemented successfully, the growth of the company and the level of satisfaction of the customer will be improved.

REFERENCE

1. Muruganantham.S(2017), "A study of consumer satisfaction towards online shopping with special reference to Coimbatore city", *International Journal of Applied Research*, Volume 3(12), pp.no: 171-174.
2. Dr.R.Shanthi and Dr.Destikannaiah (2015), "Consumers' perception on online shopping", *Journal of Marketing and Consumer Research*", Volume 13, pp.no:14-20.
3. Aminul Islam (2011), "Consumer Satisfaction on online shopping in Malaysia", *International Journal of Business and Management*, Volume 6, Issue 10.



A STUDY ON CUSTOMER SATISFACTION TOWARDS RAPIDO BIKE TAXI SERVICES

Mr. A David

*Assistant professor, Department of Commerce with Professional Accounting
Dr. N. G. P Arts & Science College, Coimbatore*

Mr. M.Pyntamil

*III B.Com (PA), Department of Commerce with Professional Accounting
Dr. N. G. P Arts & Science College, Coimbatore.*

ABSTRACT

This study said that in this modern business economy it is very important to analyses the marketing strategy used in the Rapido bike taxi. The study result shows the majority of the consumers are satisfied with the Rapido bike taxi but also there is a drawback such as hike in price and such other factor like design of the product. If necessary steps to re-solve problems of retaining customers of Rapido bike taxi will be high. It will develop the strategy of marketing, if the company can understand the preference and overall perception of the consumer. Hence, it will develop the marketing strategy and market share of Rapido bike taxi Company.

KEY WORDS-*Customer Satisfaction, Marketing strategy, modern business economy, analyses*

INTRODUCTION

Rapido is an online bike taxi aggregator based out of Bangalore, India. The company was founded in 2015 in Banlogre. It operates in more than 95 cities across the country. In the same year(2015) rapido company was founded by – Aravind Sanka, Pavan Guntupalli, and SR Rishikesh founded by Aravind Sanka, the company has sky rocketed into fame in the few years of its launch and was appreciated by huge investors in the region. They recently made headlines when they earmarked 200 Crore for marketing budgets.

The consumer market is filled with opportunities and possibilities to develop. Every market place has a pivot point. In the case of e-tailors, it is the consumers whose appetite for discounts leads them to flame venture capitalists. The passenger vehicle segment is one of the most sought after and fast growing market in India. The increasing population and limited infrastructure adds to the opportunity to grow, especially attracting the Investors and the son of soil to invest in the competitive manner, which in turn leads to more attractive services at affordable rates to the customers. There is a mushroom growth of taxi service providers like Ola, Uber, Meru, Yellow, Fast track, Friends Track, etc. In the case of

on-demand taxi aggregators such as Uber, Ola, and Rapido bikes, it is the drivers.

The taxi market scenario in india in huge scenario the taxi market in india is divided into two major segment which are the organized and unorganized .the unorganized market has a market value of \$8.5 billion and organized market holds a market value of \$500 million. The Indian taxi fore cast grow at CAGR of 13.7% during 2017-2022. the organized sector in the recently emerged segment in the market scenario.

STATEMENT OF PROBLEM

Bike taxi startups have to face a variety of challenges ranging from the accumulation of funds to regulations. Unless the companies can find a way around the challenges, we can't expect it to become a viable mode of transport Very few states in India have a legal framework for bike taxis and lack regulations for the industry. Some of the companies like Ola and Rapido had run into troubles with the administration who don't consider the service to be legal.

NEED OF THE STUDY

In the recent years of rapid growth on rental



services, there is tremendous increase in the usage of bike taxi services in all cities, especially in metros. In every sphere of business, the service and quality should be matched with the perceived, expected and delivered. The big market players in bike taxi services are keen in enhancing the products and services to tap the customer base. This study will help us to know the customers satisfaction rapido service quality and staff courtesy, etc. Also, we can have the input and ideas to improve the services to meet out the customer expectation in the near future.

RESEARCH METHODOLOGY

A Research methodology or involves specific techniques that are adopted on research process to collect, assemble and evaluate data. It defines these tools that are used to gather relevant information in a specific in a research study.

REVIEW OF LITERATURE:

Dr .Ms. Latika Ajitkumar Ajbani “, (2019)“A Study of Customers’ Outlook towards Ola Cabs Services ” There are many cab service providers such as Ola, Meru, Uber etc. who are aggregators connecting customers with drivers through technology such as mobile application. Technological advancements have impact on lifestyle. Convenience, safety, comfort, timely service are the factors which determine quality of services leading towards customer satisfaction. For this research data was collected from 50 Units (25 Male and 25 Female sample respondents) residing in Nashik city, India. From the study it is found that customers prefer Ola Cabs in Nashik city. Safety and convenience are the major factors which influence customers to select Ola Cabs services.

Ashish Avinash Khade & Dr. Vaibhav Patil “,(2018) “ A study of customer satisfaction level of ola and uber paid taxi services with special reference to pune city ” In this paper an attempt has been made to study the customer satisfaction level of the people who are using OLA and UBER cabs in Pune city. In the paper it shows who is leading the paid taxi market in Pune city, reasons for choosing OLA/UBER over other Auto/Bus services. It has also been seen that almost 100% respondents are using paid taxi services in Pune city.

HISTORY OF PROFILE OF THE STUDY

Rapido is an online bike taxi aggregator based out of Bangalore, India. The company was founded in 2015 in Bangalore. It operates in more than 95 cities across the country. Founded by Aravind Sanka, the company has sky rocketed into fame in the few years of its launch and was appreciated by huge investors in the region. They recently made headlines when they earmarked 200 Crore 28 Million for marketing budget The company was founded in 2015 as the Karrier by two alumni and a [PESU](#) alumni – Aravind Sanka, Pavan ,Guntupalli, and SR Rishikes.

Rapido today completed 1 lakh+ rides and 50,000 App downloads making it the first bike taxi service in India to achieve these milestones together. Rapido is the swiftest, cost-effective and secure mode of local travel in Bangalore and Gurgaon. Rapido has shown immense growth since its inception in November 2015. Rapido has 500+ riders on road on a daily basis in Bangalore and has up to 85% of repeat customers every day. The App now has reached a milestone and has also garnered 4 star app rating and 100% app bookings.

VISION STATEMENT

- The vision statement is a company's road map, indicating what the company wants to become by setting a defined direction for the company's growth.
- Vision statements undergo minimal revisions during the life of a business, unlike operational goals which may be updated from Vision statements can range in length from short sentences to multiple pages.
- Vision statements are also formally written and referenced in company documents rather than.

FEATURES RAPIDO BIKE TAXI

- Easy Booking
- Helmet And Shower Caps
- Insured Riders
- Economical



**HOW DOES THE RAPIDO WORKS
CLONE SCRIPT WORKS?**

- Ride Request
- Ride Acceptance
- Pick Up
- Drop
- Payment
- Rating

**DATA ANALYSIS AND
INTERPRETATION**

In this chapter the analysis interpretation of the study on “Consumer satisfaction towards Rapido - bike taxi “ is presented based on the opinion of sample of 120

respondents selected from coimbatore city through a questionnaire containing 18 questions analyzed through

1. Simple percentage analysis.
2. Rank analysis method.

SIMPLE PERCENTAGE ANALYSIS

Simple percentage analysis is carried out for the all questions gives in questionnaire. This analysis describes the classification of the respondents failing each category. The percentage analysis is used mainly for the standardization and comparisons are support with the analysis.

FORMULA,

$$\text{Percentage Analysis} = \frac{\text{Number of respondents}}{\text{Total number of respondents}} * 100$$

**TABLENO:1
TABLE SHOWING GENDER OF THE RESPONDENTS**

S.NO	GENDER	NO.OF RESPONDANTS	PERCENTAGE %
1	Male	100	83
2	Female	20	17
	TOTAL	120	100

Source: Primary data

INTERPRETATION

The above table shows that 83% of the respondents are male 17% of the respondents were female.

REFERENCE

Majority (83%) of the respondents were male.

SIMPLE RANKING ANALYSIS METHOD

A ranking is a relationship between a set of items such that for any two items the first is either “ranking higher than, ranking lower than equal to the second

**TABLE NO 2****TABLE SHOWING THE PREFERENCE LEVEL OF RAPIDO BIKE TAXI TO THE RESPONDENTS**

S.NO	FACTORS	RANK 1	RANK 2	RANK 3	RANK 4	TOTAL	RANK
1.	Specification	86(4)	11(3)	13(2)	4(1)	407	I
2.	Services	23(4)	61(3)	24(2)	6(1)	329	III
3.	Online payment	42(4)	38(3)	43(2)	10(1)	378	II
4.	Time keeping	30(4)	24(3)	34(2)	38(1)	298	V
5.	Safety to taxi ride	26(4)	37(3)	39(2)	18(1)	311	IV
6.	Performance	19(4)	27(3)	39(2)	26(1)	261	VI

Source data: primary data

INTERPRETATION

Its is observed from the above table that specification ranked first , online payment ranked second , services ranked third , safety to taxi ride ranked in fourth,time keeping is ranked fifth ,performance is ranked sixth .

REFERENCE

Specification has been 1st ranked.

FINDINGS, SUGGESTIONS AND CONCLUSION FINDING

SIMPLE PERCENTAGE ANALYSIS

- Majority (83%) of the respondents were male
- Majority (48%) of the respondents were 21 years to 30 years.
- Majority (59%) of the respondents were Under Graduate
- Majority (58%) of the respondents are RS 30000 to 5000
- Majority(54%) of the area of respondents URBAN
- Majority (67%) of the area of bike taxi services in respondents
- Majority(63%) of the area of respondents weekly onces.
- Majority (61%) of the anyone recommended bike taxi services respondents.
- Majority (61%) medias of the bike taxi services respondents.
- Majority (78%) the factors of yes compare between the Rapido taxi with other taxi system.
- Majority (71%) the respondents are type of the online payment use of the respondents
- Majority (78%) the factors of yes compare between the Rapido taxi with other taxi system
- Majority (78%) the factors of yes compare between the Rapido taxi with other taxi system

SIMPLE RANKING METHOD

- ▲ Specification has been 1stranked.
- ▲ Uber moto has been 1stranked
- ▲ Safety has been 1stranked

SUGGESTIONS

Thus study suggested that the marketing techniques and strategies can be improved for Rapido bike taxi. Most of the respondents came to know about the Rapido bike taxi services only through the family members and friends. The study suggested that the design of the mobile phone can be further improved. To price offers / discount offers to attract more member of customers .

CONCLUSION

This study concluded that in this modern business economy it is very important to analysis the marketing strategy used in the rapido bike taxi services. The study result shows the majority of the consumers are satisfied with the rapido bike taxi services but also there is a drawback such as hike in price and such other factor like design of the product. If necessary steps to re solve problems of retaining customers of rapido bike taxi services will be high. It will develop the strategy of marketing, if the company can understand the preference and overall perception of the consumer. Hence, it will develop the marketing strategy and market share of rapido bike taxi services.

REFERENCE

1. Dr.Ms. Latika Ajitkumar Ajbani (2019) “, A Study of Customers’ Outlook towards Ola Cabs Services ISSN: 0374-8588 Volume 21 Issue 10, November 2019 the journal Gujarat research society Yashwantrao Chavan Maharashtra Open University, Nashik (Maharashtra).¹⁰
2. Ashish Avinash Khade & Dr. Vaibhav Patil (2018) “, a study of customer satisfaction level of ola and uber paid taxi services with special reference to pune



- cityInternational Journal of Management, Technology And Engineering Volume 8, Issue VIII, AUGUST/2018 ISSN NO : 2249-7455*
3. Prof. Manjunath.G (2015)“, *Brand Awareness and Customers Satisfaction towards OLA Cabs in Bengaluru international research and publication ISSN NO : 2251 1571*
 4. Dr. S. M. Yamuna (2019) “, *A Progressive Study on Users Perception and Satisfaction towards Online Cab Service with Reference to Coimbatore . International Journal for Research in Applied Science & Engineering Technology (IJRASET) ISSN: 2321-9653; IC Value: 45.98; SJ Impact Factor: 6.887 Volume 7 Issue IV, Apr 2019- Available at www.ijraset.com*
 5. Dr. Ruchi Shukla “,(2017) (*OLA VS UBER: The Battle of Dominance*) Every other day in India, there is a new start up offering efficient cab service to the citizens operating in urban and rural lifestyles. This raises a question that is India going through a possible 'Taxi Revolution.
 6. *IOSR Journal of Business and Management (IOSR-JBM) e-ISSN: 2278-487X, p-ISSN: 2319- 7668 PP 73-78 www.iosrjournals.org*
 7. Dr. Ashok Kumar Panigrahi (2018) *A Case Study of OLA Cabs IOSR Journal of Business and Management (IOSR-JBM) e-ISSN: 2278-487X, p-ISSN: 2319-7668. Volume 20, Issue 2. Ver. II (February. 2018), PP 30-37 www.iosrjournals.org*
 8. Dr. Kanjer Hanif (2016) “, *An Empirical Research on the Penetration Levels for a Call- a Cab Service in Mumbai Penetration Levels for a Call-a-Cab Service* in *MumbaiReflectionsJournalofMaanagement,5,<http://reflections.rustomjee.com/index.php/reflecti> one/issue/view/3/show*



QUESTIONNER

A STUDY ON CONSUMER SATISFACTION OF RAPIDO BIKE TAXI SERVICES WITH SPECIAL REFERENCE TO COIMBATORE CITY

1. Name _____

2. Age

- a) 15-20 years
- b) 21- 30 years
- c) 31- 40 years
- d) Above 40 years

3. Gender

- a)Male
- b) Female

4. Educational qualification

- b) Upto Schooling
- B)Graduates
- C) Post Graduates
- D) Professionals

5. What is the yearly income of the bike taxi drivers?

- a) less than Rs.300000
- b) Rs.30000 – Rs.50000
- c) Rs.50000 –Rs.100000
- d) more than Rs.1000000

6. Area of residence

- a) Urban
- B) Semi- Urban
- C) Rural

7. What was the consumer purpose of using the bike taxi services?

- a) Commercial
- B) Personal
- C) Both A & B
- D) Long Trip

8. Periodic usage of rapido in bike taxi services?

- a) Daily Once
- B) Weakly Once
- C) Monthly Once
- D) Yearly Once

9. Does anyone recommend your to consumer rapido bike taxi?

- a) Yes
- b) no

10. How did you come to know about the rapido bike taxi?

- a) Relative
- B) Media
- C) Friends
- D) Advertisement

11. The consumers satisfaction level towards quality of rapido bike taxi as follows

Specification	Average	Good	Better	Best
Services				
Online payment				
Time keeping				
Safety to ride taxi				
Performance				
Interiors				



12. Did you compare the rapido taxi with other taxi services ?

- a. Yes
- b) No

If yes, what was the Comparative position of bike taxi services provided with other brands?

TAXI BRAND	Rank
Uber taxi	
Olo taxi	
Fast track taxi	
bikie taxi	
Others	

13. Will you recommend bike taxi to others?

- a) Yes
- b) No

14. What was your preference among the rapido bike taxi ?

- b) Olo Taxi
- B) Uber Taxi
- C) Fast Track

15. What type of the payment did made you made at the time of taxi driver ?

- c) Cash Payment
- B) Online Payment

16. Ranks given to the various facilities provided consumer by the rapido bikes asfollows

Facilities	Rank
Price	
Safety	
Driving & seating comfort	
Quick way ride	
Online payment	

17. Whether the bike taxi easily available in Coimbatore city?

- a. Yes
- b) No

18 .By comparing with other taxi, the driving comfort of any other call taxi services is

- b. Average
- b) Good
- c) Best

19. Mention any suggestions_____.



A STUDY ON INCOME GENERATION POTENTIAL OF WOMEN SELF-HELP GROUP WITH SPECIAL REFERENCE TO TIRUPUR

Dr. Vanaja

*Head of Department, Department of Commerce with Professional Accounting
Dr. N.G.P. Arts and Science College, Coimbatore*

Ms. Pavithra.S

*III B. Com (Professional Accounting), Dr. N.G.P. Arts and Science College
Coimbatore*

ABSTRACT

Self – help group is an informal and voluntary of neighbourhood people with equal status formed for fighting for common causes. Self Help Group is a registered or unregistered group of micro entrepreneurs with a homogenous social and economic background, voluntarily coming together to save small amounts regularly and mutually agreeing to contribute to a common fund to meet their emergency needs on mutual help basis”. A number of public and private sector banks have realised the potential of microfinance as a viable business option and have commenced operations already. It is also interesting to note that SHG is now being recognised as a socially viable unit for implementation of various other programmes, like micro-watersheds. Meeting ends refer to the ability of surviving with the amount available for a particular period, most of an Indian situation-a month. It was an interesting opportunity to prob into the rural women entrepreneurship. The study has further scope of explore into the growth and performance of the self-help group.

KEYWORDS: *Self- Help group, (SHG), Income Generation Potential, performance – For common causes like poverty, illiteracy, violence and deprivation of basic necessities of life.*

INTRODUCTION

Self-Help Group is a small voluntary association of poor people preferably from the same socio-economic back drop. The micro-credit given to them makes them enterprising. A Self-help group usually composed of 10-20 local women. In India, many SHGs are ‘linked’ to banks for the delivery of micro credit for small. The Self-Help Group being comprised of group of persons get empowerment to solve most of their problems of non- financial marketing, better adoption of technology and training for realizing the human potential for entrepreneurial development.

time to time for the upliftment of poor unemployed women and under unemployed rural and urban poor for over five decades. Yet, eradication of poverty and generation of gainful employment for the poor of our nation remains a distant dream for our planners. The schemes implemented from time to time hardly have made any dent in the enlistment of the poor from the clutches of poverty. In every society, poverty affects preliminary women and children. Hence, programs and schemes are required for the enlistment of the poor, especially rural women. The participation of women in economic activities is often considered important for the economic and social empowerment of women.

STATEMENT OF THE PROBLEM

The Government of India and various state government have introduced many programs from

The study has been confirmed only to the study of income generation potential for women self-help groups in Tirupur. For instant, a comparative



study of women SHGs with that of youth SHGs, a comparative study on marketing strategy adopted by retail sellers and SHGs, the study of income generation potentials of women SHGs in Tamil Nadu State and the like may be the other area.

SCOPE OF THE STUDY

The study is undertaken to assess the role of self-help groups in developing the rural women entrepreneurs and examine their participation in income generating activities and levels of living of the women after joining self - help groups. The current research helps to know the study is attempts to assess the extent of entrepreneurial development achieved by women after becoming members of SHGs.

OBJECTIVES

The following funding are the main objectives of the present study:

1. To study growth trends of women self-help group in Tirupur.
2. To study the income generation potential of women self-help group in Tirupur.
3. To analyse the problems faced by the women in income generating activities in the Tirupur.
4. To analyse the role of various agencies to promote income generation activities of women through self-help group.

RESEARCH METHODOLOGY

Research methodology is the systematic way to solve research problem. It is a science of studying how research is to be carried out. Its aim is to give work plan of research. The study is based on a survey collected with the help of primary and secondary data.

DATA USED: Primary and Secondary data are used

SAMPLE SIZE: The study was conducted with a sample of 120 respondents.

ANALYTICAL TOOLS USED: Simple percentage analysis & Likert scale analysis.

REVIEW OF LITERATURE

Dr Uma Narang (2012), "An Effective approach to women empowerment in India", studied that SHGs have been identified as a way to alleviate poverty and women empowerment. An women empowerment aims at realizing their identities, power potentiality in all spheres of lives. But the real empowerment is possible only when a women has increased access to economic resources, more confidence and self-motivation, more strength, more recognition and say in the family matters and more involvement through participation, Thus self-help group have been showing the way ahead to alleviate the poverty of India along with women empowerment.

P. UmaMaheshwari, (2013), "A Study on social impact of women self help groups in Mettur", The objective of study are to study the social impact of women SHGs, o analyze the change in the social condition SHGs, to measure the impact of the SHGs on the social condition members, and to analyze the attitude of the members of the SHGs towards social impact. Only the primary data has been made used off the purpose of analysis. Primary data have been collected through a field survey.

HISTORY AND PROFILE OF THE STUDY

The Programme is implemented in partnership with NGOs and Community based organizations which are affiliated with TNCDW (Tamil Nadu Corporation for Development of Women) after due process. So, far 9,803 SHGs have been formed in the district. The members and office bearers of the SHGs promoted by Mahalir Thittam are provided Systematic training to bring about qualitative changes in their attitude and to promote cohesion and effective functioning of the group.



ANALYSIS

TABLE SHOWING THAT RESPONDENTS ON THE BASIS OF TYPE OF BUSINESS

TYPE OF BUSINESS	RESPONDENTS	PERCENTAGE
Garments production	60	50
Handloom	21	17.50
Mini dairy firm	37	30.83
Other	2	1.67
Total	120	100

INTERPRETATION

It is understood that the above table shows out of total 120 respondents 50% of the respondents are engaged in the field of garment production, 17.50% of the respondents are engaged in the field of handloom, 30.83% of the respondents are engaged in the field of mini dairy firm and 1.67% of the respondents are engaged in the field of other.

INFERENCE

It is concluded that majority (30.83%) of the respondents are engaged in the field of Mini dairy firm.

TABLE SHOWING THAT RESPONDENTS ON THE BASIS OF LEVEL OF AWARENESS IN SAVINGS

AWARENESS IN SAVINGS	RESPONDENTS	LIKERT SCALE VALUE	TOTAL VALUE
Agree	40	5	200
Strongly Agree	9	4	36
Neutral	50	3	150
Disagree	20	2	40
Strongly Disagree	1	1	1
Total	120		427

INTERPRETATION

LIKERT = $\frac{\sum(fx)}{\text{Total number of respondents}}$
 $= \frac{427}{120}$
 $= 3.5$

INFERENCE

Likert scale analysis 3.5 so the respondents is Neutral.

FINDINGS FROM PERCENTAGE ANALYSIS

- The survey revealed that most (50.83%) of the respondents are in the age group between 30-40 years.
- It is found that most (60.83%) of the respondents are from Nuclear family.
- It is resulted that majority (92.50%) of the respondents are working up to 2-4 hours.
- It is concluded that majority (50.83%) of the respondents are from rural area.
- It is resulted that majority (57.50%) of the respondents are degree & above.
- The survey resulted that majority (49.17%) of the respondents are Unmarried.

- The survey revealed that most (59.17%) of the respondents are self employers.
- It is resulted that majority (80%) of the respondents are in the 20-30 group members.
- It is concluded that majority (60%) of the respondents are between 1-2 years.
- It is concluded that majority (75.83%) of the respondents are agreed that activities are under taken by All the members.
- The survey revealed that majority (61.67%) of the respondents that Relatives motivated to join SHG
- The research found that majority (75%) of the respondents for the purpose of joining in SHG is to get loan.
- The research found that majority (65%) of the respondents are earning Rs.5000-10000 before joining SHG.
- The research found that majority (84.17%) of the respondents is earning Rs. 30000–35000 after joining SHG.
- The research found that majority (83.33%) of the respondents has payment of loan under monthly basis.



- It is concluded that majority (41.67%) of the respondents are utilized the loan amount for the purpose of other.
- It is concluded that majority (66.67%) of the respondents are faced family responsibilities before joining in SHG.
- It is concluded that majority (78.33%) of the respondents are financially faced by the members is Repayment of loan
- It is concluded that majority (42.50%) of the respondents are Decision making is the skill have been earned.
- It is concluded that majority (%) of the respondents are Production is difficulty faced in income generating activity.
- It is concluded that majority (50%) of the respondents are engaged in the field of Garment production.

FINDINGS FFROM LIKERT SCALE ANALYSIS

- Likert scale value is 3.5 which is greater than 3, so the respondents are neutral.
- Likert scale value is 3.2 which is greater than 2, so the respondents are disagree.
- Likert scale value is 2.9 which is greater than 2, so the respondents are disagree.

SUGGESTIONS

Based on findings the following suggestion are made to the study on Self-Help group with special reference to Tirupur:

- The study suggested that it is necessary to educate rural women to upgrade and improve their skills, provide opportunity for them to express their potential abilities for addressing social, economic and technical problems of members.
- Many of the women entrepreneurs faced the problems of adequate loan amount. Loan amount should be increased to the extent that they can take up an income generating activity.
- The survey observed that motivational factors to join SHGs are very low. Hence, it is suggested that Government and Non-Government organization should conduct various programs to create awareness about the SHGs and provide counselling to the members to become successful entrepreneurs.
- Only half of the respondents have received training and orientation for capacity building. It is suggested that training on innovative economic activities by using the resources should be given to the SHGs members. Participation in training programs should be taken by all the members in SHGs.

- The research found that most of the women are unaware about the business, hence necessary steps should be taken by the SHGs to provide knowledge about production sales and brandings.

CONCLUSION

The study conclude that participation of women in income generating activities are increased with the help of SHGs and the performance of SHGs in this district was good. The great percentage of women were impacted positivity by members of SHGs. Women's participation in SHGs enable them to discover inner strength, gain self -confidence, social, economical, psychological and capacity building. Over the past few decades the women has been braking traditional role of mother or a house wife. It is clear from the study that women entrepreneurs of SHGs has good workforce, under the dynamic settings business, if women entrepreneurs are given proper guidance and training to enhance the profitability of the enterprises the future will be bright and prosperous.

REFERENCE

1. K. Poornima – “Women Entrepreneurship & Empowerment through Self Help Groups in Tumkur District”, *New Horizon International Journal of current Engineering and Technology*, Sep 2013, pg no:79-83.
2. Dr R. V. Tehra – “An Empirical Case Study of Women Self Help Group Functioning in Nanded City”, Oct-2014, Vol. 3. Pg. no. 53-61.
3. M. Saravanan, “The Impact of Self - Help Group on the socio-economic development of rural household women in Tamil Nadu, *International journal of Research*, Vol.4 No.7:SE: July, 2016, pp 22-31
4. Shweta Singh, Guido Ruivenkamp and Joost Jongerden – “A State of the art of self-help groups in India, critical technology construction, research group of social sciences department, *Journal of Human Ecology*, Nov-2011, Vol. 36(2), pg. no. 91-102.



WAYS OF IMPROVING EFFECTIVENESS IN TEACHING FOREIGN LANGUAGES: AUDIO-LINGUAL APPROACH IN ENGLISH LANGUAGE

Jumayev Sanjar Jurakulovich

*Senior Teacher of the Foreign Languages Department,
Karshi Engineering-Economics Institute, Karshi City, Uzbekistan*

ABSTRACT

The aim of this article is to explore strong and weak readers' use of listening strategies when audio-lingual tasks, such as dialogues, texts and giving particular situation. Audio-lingual approach can bring out key information and provide poor listener with a more version of the text. Apart from that, the learners' ability to listen will expand their engagement with the text as well as motivate to further listening.

KEYWORDS: *approach, teaching, grammar translation method, communicative competence, innovative, linguists, language skills, training techniques, psychology, communicative competence.*

DISCUSSION

Audio-lingual approach of teaching English as a second language had its origins during World War II when it becomes know as the Army approach. It was develop as a reaction to the grammar-translation approach of teaching foreign languages. Grammar-translation had been use to teach for thousand of year. However, the method was perceived as taking too long for learners to be able to speak in the target language. The Audio-Lingual approach set out achieves quick communicative competence through innovative approaches. In the other words, 1947-1967 the Audio-Lingual Approach was the dominant foreign language teaching method in the United States [1,56].

The US military provided the impetus with funding for special, intensive language courses that focused on aural/oral skills; these courses came to be known as the Army Specialized Training program (ASTP) or, more colloquially, the "Army Method". The Audio-Lingual approach is the product of three historical circumstances. For its views language, Audio-Lingual drew on the work of American linguists such as Leonard Bloomfield. The prime concern of American linguistics at the early decades of the 20th century had been to document all the indigenous languages spoken in the USA. However, because of the dearth of trained native teachers who would provide a theoretical description of the native

languages, linguists had to rely on observation. For the same reason, a strong focus on oral language was developed. At the same time, Behaviorism psychologists such as B. F. Skinner was forming the belief that all that all behavior (including language) was learnt through repetition and positive or negative reinforcement. The third factor that enabled the birth of the Audio-Lingual approach was the outbreak of World War II, which created the need to post large number of American servicemen all over the world. At that time, there was a need for people to learn foreign language rapidly for military purposes [2,45].

The Audio Lingual Method has introduced memorization of dialogues and imitative repetition as specific learning techniques. This method emphasizes the teaching of listening and speaking which did not gain so much importance from Grammar translation method. The language skills are taught in the order of listening, speaking, reading, and writing. It uses dialogues as the main from of language presentation and drills as the main training techniques. Mother tongue is discouraged in the classroom. Moreover, teaching technique with tape recordings and language lab drills offer practice in speaking and listening, which are considered of primary importance in language learning. Reading and writing are limited but not ignored, it should be presented gradually after the students are considered capable enough and the material should keep



seriously to what students has heard and repeated. The purpose of this method is to rapid the acquisition of listening and speaking skills by drilling the students in the use of grammatical sentences patterns [3,78].

The Audio lingual Classes concentrated on long repetition-drill stages, in which the teacher hoped that the students would acquire good language habits. By rewarding correct production during these repetition phases, students could be conditioned into learning the language. Behaviorist psychology states that people are conditioned to learn many forms of behavior, including language, through the process of training or conditioning [3,79].

There are four basic drill types in this methods: those are: simple repetition, substitution, transformation and translation. It can be inferred that the main activity of this method is drilling from simple repetition to the translation. The teacher has to motivate the students to learn English in the class, he/she is a central and active role in the teaching and learning activities. From the statements above, the writer comes to the understanding that the Audio Lingual approach is a followed behaviorism theory. This approach emphasizes on listening and speaking by imitating, repeating and memorizing grammatical structure through substitutions, singular-plural and tense transformations etc, using the target language and the culture where the language is spoken. Correct responding the stimuli must be done by the students continuously in order to become a habit. Audio-Lingual approach or audiolingualism is a method or style of teaching used in teaching foreign languages. It is based on behaviorist theory, which professes those certain traits of living things, and in this case humans, could be trained through a system of reinforcement. It is based on behaviorist theory which is the belief that learning should be based on psychological study of observable and measurable psychology only; psychological theory based on stimulus-response influenced audiolingualism. This approach is similar to the previous one, the direct method Like the direct methods the audio-lingual method supposed that the students are taught a foreign language directly, without using the students' native language to explain new words or grammatical rule in the target language. However, unlike the direct method, the audio-lingual approach does not focus on teaching vocabulary. Rather, the teacher drills the students in the use of the spoken grammar. This concept in strongly associated with the American psychologist B.F. Skinner (1904-1990). The philosophy behind behaviorist models is that learning takes place through interaction with the world through exposure to examples, positive and negative stimuli, and then trail and error rather than from any inner faculty [4,17].

On the other hand, Freeman states the Audio-Lingual Method drills students in the use of grammatical sentence pattern. It indicates that the focus of this lesson is to improve students' target language communicatively. The Audio-Lingual Method consists of eleven techniques which can be achieved to be implemented in this study in order to ease the research later on. They are single-slot substitution drill and transformation drill. The consideration why I take those techniques to be implemented in this study is to check the students' grammatical sentence pattern.

Anggraeni (2007) conducted a research entitled the audio-lingual approach as a alternative method in teaching speaking to Junior High school. Meanwhile, the other researchers like Kharisma (2001) also held the research about a comparative study on the speaking achievement of students taught through the Audio-Lingual Approach. Ardiyanto (2009), also conducted a research which still focused on Audio-Lingual Approach entitled the comparison of speaking achievements between students taught using the direct method and the ones taught using the Audio-lingual Method to influence the speaking ability [5,97].

The Audio-Lingual method mainly consists of the following features:

The teacher reads a dialogue by modeling it. It has been always motivating to put the subject matter in context, and students stand a better chance of retaining what they have learnt. Students learn the target language within a concrete context that will enable them to relate what they learn to real-life learning environments. Teachers as a role model will encourage and inspire the students to strive for learning the target language.

Students repeat the dialogue. Through repetition students can use the target language automatically, and fluently as well. In this method it is desirable that students form a habit formation to use the target language with ease, therefore, the more they repeat, the easier they will speak the target language without thinking.

Some words or phrases are changed in the dialogue. Drills used in this method will allow the students to have practice. Through drills such as single-slot substitution, multiple slot substitution, and transformation students are given the opportunity to produce speech in the target language, furthermore, these patterns will let them see how language functions. Students learn how to respond correctly when they practice the drills.

For many years, audiolingualism did not receive priority in language teaching. receptive and productive skills was poorly understood. Until recently, the nature of listening in a skills could be



acquired through exposure but not really taught. This position has been replaced by an active interest in the role of listening comprehension in the second language acquisition, by the development of powerful theories of the nature of language comprehension, and by the acquisition and therefore demands a much greater prominence in language teaching. The papers in this section explore the nature if the second language listening and principles for the design of teaching activities and classroom materials [6,31].

Field examines a commonly used format for the teaching of listening, one which involves three stages in a listening: pre-listening, listening, and post-listening. He points out the limitations of some activities often used at these different points in a lesson: Materials and teaching often tend to test listening rather than teach it and do not practice the kind of listening that takes place in real life. Field advocates the use of preset questions, the use of task-based listening activities, a focus on strategies and a greater use of authentic materials and shows these recommendations affect the typical three-part listening lesson. He also shows how the teacher's role is crucial in the teaching of listening. The teacher is not there simply to check answers but rather to actively guide learners through the processes of listening, monitoring their listening difficulties, and reshaping classroom tasks to provide maximum opportunities for learner involvement and to develop a better awareness of how to listen.

Lam points out that many ESL listening materials fail to provide examples of genuine spoken language since devices typically used by speakers, such as filler, fragments, and compensation devices, are often omitted. She illustrates ways in which learners can develop awareness of the syntax and organization of spoken discourse in order to facilitate their ability to process spoken texts. These activities integrate both listening and speaking and seek to prepare learners to handle the demands of real-world communication. Language learning from the view of behavioural psychology on the other hand, occurs by conditioning and habit formation of accurate responses to stimuli. The right response for a stimulus is modeled by the teacher beforehand and then drilled into the learners repeatedly until such responses become "habit" that enables learners to successfully produce accurate responses without clues or prompting by the teacher. This discussion aims to further understand the Audio-lingual Method and explore the advantages and disadvantages of employing it in the second language classroom. The author also puts out her recommendations for the use of the ALM in the second language classroom.

LIST OF USED LITERATURE

1. *Language and Language Learning: Theory and Practise*, 2nd ed New York: Harcourt brace. 1964, -65 p.
2. Nunan, D. *What's my style?* In D. Gardner and L. Miller (eds.), *Tasks for independent language learning*. Alexandria: TESOL. 1996, 45-68 p.
3. Rivers, Wilga. *Teaching Foreign Language Skills*. Chicago: University of Chicago Press. 1968, 62-72 p.
4. Richards, J. C., and Rogers, T. S. *Approaches and methods in language teaching: A description and analysis*. Cambridge: Cambridge University Press. 2001, 87-97 p.
5. Brown, H. Douglas. *Teaching by Principles: An Interactive Approach to Language Pedagogy*, Second edition. New York: Addison Wesley Longman, Inc. 2001, P-97.
6. Halliday, M. A. K. *Spoken and written language*. Oxford: Oxford University Press. 1989, -31 p.
7. M. Erkinova. *Audition as a method of boosting of a level in the English language*. Samarkand. 2020. P-8-16.