



# SPEED AND DIRECTION CONTROL OF DC MOTOR USING ANDROID MOBILE APPLICATION

**N. Balakrishna<sup>1</sup>, L. Vijay Kumar<sup>2</sup>, S. Sandeep<sup>3</sup>, D. Durga Prasad<sup>4</sup>,  
B. Srikanth<sup>5</sup>**

<sup>1,2,3,4</sup>UG Scholars, Department of EEE, Aditya Institute of Technology and Management, Tekkali, Andhra Pradesh, India.

<sup>5</sup>Assistant Professor, Department of EEE, Aditya Institute of Technology and Management, Tekkali, Andhra Pradesh, India.

Article DOI: <https://doi.org/10.36713/epra10539>

DOI No: 10.36713/epra10539

## ABSTRACT

Today most widely used systems are wireless because these systems are less in cost and more efficient than wired systems. In wireless systems, we do not use wires so these systems are light in weight and free from line losses i.e. losses due to the current flowing in the wires. Wires are easily affected by environmental conditions, so wired systems are not so good. In wireless systems, the data is transmitted through the Electromagnetic Waves, and these waves are not affected by the environmental conditions. Also, the environment is not affected by these waves. Hence this is an eco-friendly method. Today motors are everywhere. In every industry, motors are playing a great role-someone appliances motors are playing a common role. This project is about the wireless operation of a DC Motor. We are controlling the speed and direction of a DC motor by using the Android Mobile application. To control the direction of the motor we use the H-Bridge operation of the IC motor driver and control the speed of the DC motor by using the PWM technique.

**KEYWORDS:** ARDUINO, Android mobile, DC Motor, Motor driver IC, Bluetooth module.

## 1. INTRODUCTION

Speed controlling of DC motors plays a very crucial role. Monitoring and controlling the speed of a DC motor by using Android Smartphones have involved Bluetooth technology, so an outer Bluetooth module HC05 is interfaced with the PIC microcontroller unit for the wireless connection. The Bluetooth module obtains a signal from the smartphone mobile android app. Therefore, according to the I/P signal, with the use of PIC, an IR sensor can be usually used to vary the speed as well as for the DC motor by using PWM techniques. Direct Current motor direction can also be varied with the use of a driver circuit or H-Bridge network. The electric drive systems should possess some benchmark properties like linear control, reliability, and steady operation. DC-driven machines gain some advantage in these aspects. The speed control methods of DC motors play a vital role in the performance of the drive. The main purpose of the speed controller is to focus on how we can use Bluetooth-based devices to control the speed and direction of a DC motor at the desired speed and the main objective of a dc drive is to maintain a system with a stable speed irrespective of load condition. In this paper, we describe a recently

developed “Android-based speed control of DC motor”, a smartphone control experimental setup that can be accessed via Bluetooth. This setup consists of two basic primary elements communicating with each other: i) Bluetooth of smartphone which is connected to the microcontroller, IC and DC Motor interfaced with a motor driver IC and ii) a Bluetooth module. The smartphone sends/receives data to/from the microcontroller using wireless technology via Bluetooth. An application based on Android is created and downloaded on the phone which acts as a display panel for the user to send/receive/view the input and output of the DC motor. In this paper visual display of the current position of the motor using sensors can be sent by the microcontroller to the smartphone. Our microcontroller-based remote control methodology using an android based smartphone can be readily applied and control the speed of the motor through it.

## 2. BLOCK DIAGRAM AND WORKING

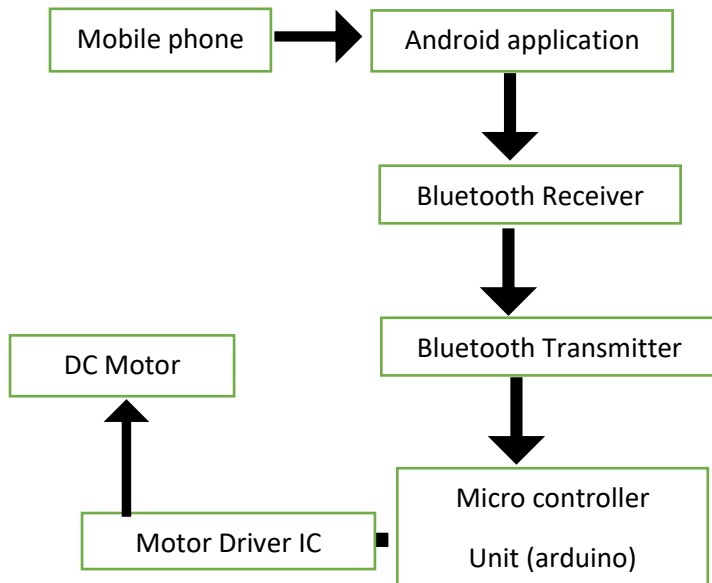

Signal from Android device will be sent through Bluetooth. This signal will be communicated with Arduino with the help of transmitter and receiver of both the devices. This signal will be represented by a binary form which denotes the speed and direction of the motor. There are three different direction of rotation: clockwise, anti-clockwise and stopping of the motor and these will be represented by different letters.

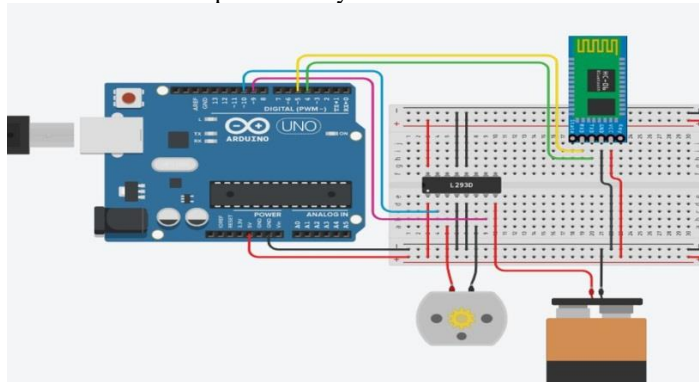

For forward direction the transistor Q1 and Q4 will be ON and for the reverse direction Q2 and Q3 will ON. Q1 and Q2 are PNP transistors which becomes ON when low signal is sent and Q3 and Q4 are NPN transistors which becomes ON when high signal. PWM pins 5 and 6 are used to control the speed of the in both directions, they use the concept of varying the duty cycle (PWM Technique). Duty cycle varies from 0 - 255. So by choosing different duty cycle speed can be varied. Direction is controlled with the concept of having H-Bridge.

## 3. RELATED WORK

The brief introduction of different modules used in this project is discussed below:

**3.1. Bluetooth Module:** HC-05 Bluetooth module provides switching mode between master and slave mode which means it able to use neither receiving nor transmitting data. Comparing it to the HC-06 module, which can only be set as a Slave, the HC-05 can be set as Master as well which enables making a communication between two separate CONTROL Boards. You can use Bluetooth module simply for a serial port replacement to establish connection between MCU, PC to your embedded project and etc.

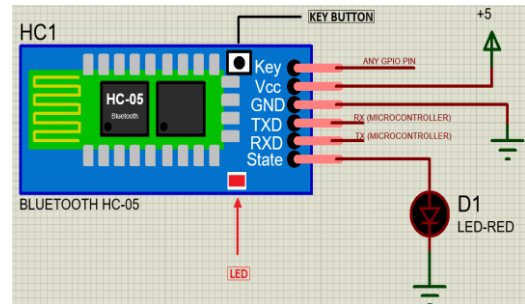

### HC-05 Technical Specifications

- Serial Bluetooth module for Arduino and other microcontrollers
- Operating Voltage: 4V to 6V (Typically +5V)
- Operating Current: 30mA
- Range: <100m
- Works with Serial communication (USART) and TTL compatible
- Follows IEEE 802.15.1 standardized protocol
- Uses Frequency-Hopping Spread spectrum (FHSS)
- Can operate in Master, Slave or Master/Slave mode
- Can be easily interfaced with Laptop or Mobile phones with Bluetooth
- Supported baud rate: 9600,19200,38400,57600,115200,230400,460800

### 3.2. DC Motor

A dc motor uses electrical energy to produce mechanical energy, very typically through the interaction of magnetic fields and current-carrying conductors. The reverse process, producing electrical energy from mechanical energy, is accomplished by an alternator, generator or dynamo. Many types of electric motors can be run as generators, and vice versa. The input of a DC motor is current/voltage and its output is torque (speed).

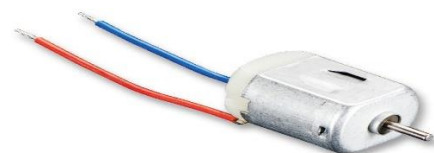

**Fig: DC Motor**

The magnetic field in the armature and field coil causes the armature to begin to rotate. This occurs by the unlike magnetic poles attracting each other and the like magnetic poles repelling each other. As the armature begins to rotate,

the commutator segments will also begin to move under the brushes. As an individual commutator segment moves under the brush connected to positive voltage, it will become positive, and when it moves under a brush connected to negative voltage it will become negative. In this way, the commutator segments continually change polarity from positive to negative. Since the commutator segments are connected to the ends of the wires that make up the field winding in the armature, it causes the magnetic field in the armature to change polarity continually from north pole to south pole. The commutator segments and brushes are aligned in such a way that the switch in polarity of the armature coincides with the location of the armature's magnetic field and the field winding's magnetic field. The switching action is timed so that the armature will not lock up magnetically with the field. Instead the magnetic fields tend to build on each other and provide additional torque to keep the motor shaft rotating. When the voltage is de-energized to the motor, the magnetic fields in the armature and the field winding will quickly diminish and the armature shaft's speed will begin to drop to zero. If voltage is applied to the motor again, the magnetic fields will strengthen and the armature will begin to rotate again

### 3.3. LCD Module



Fig :LCD

One of the most common devices attached to a micro controller is an LCD display. Some of the most common LCD's connected to the many microcontrollers are 16x2 and 20x2 displays. This means 16 characters per line by 2 lines and 20 characters per line by 2 lines, respectively.

### 3.4. PIC micro controller



Fig :Microcontroller

PIC microcontrollers ( Programmable Interface Controllers), are electronic circuits that can be programmed to carry out a vast range of tasks. They can be programmed to be timers or to control a production line and much more. They are found in most electronic devices such as alarm systems, computer control systems, phones, in fact almost any electronic device. Many types of PIC microcontrollers exist, although the best are probably found in the GENIE range of programmable

microcontrollers. These are programmed and simulated by Circuit Wizard software.

PIC Microcontrollers are relatively cheap and can be bought as pre-built circuits or as kits that can be assembled by the user.

### 3.5.DC Motor Driver

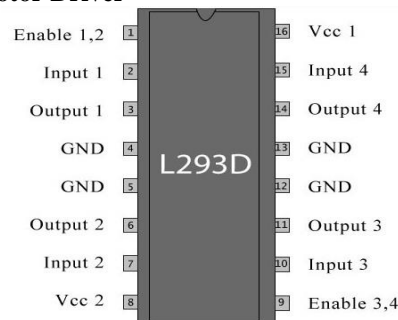

Fig: Motor Driver IC

The L293D IC receives signals from the microprocessor and transmits the relative signal to the motors. It has two voltage pins, one of which is used to draw current for the working of the L293D and the other is used to apply voltage to the motors. The L293D switches its output signal according to the input received from the microprocessor. The L293D is a 16 pin IC, with eight pins, on each side, dedicated to the controlling of a motor. There are 2 INPUT pins, 2 OUTPUT pins and 1 ENABLE pin for each motor. L293D consists of two h-bridge. H-bridge is the simplest circuit for controlling a low current rated motor.

### 4. APPLICATIONS

1. Can be used in simple robotic application to control direction and speed of signal motor.
2. Many applications require adjustable speed drive and constant speed for improving the quality product.
3. The circuit shown here control a single dc motor but can be extended to control two motors with independent speed and direction controls.
4. Home automation

### 5. CONCLUSION

Integrating features of all the hardware components used have been developed in it. Presence of every module has been reasoned out and placed carefully, thus contributing to the best working of the unit. Secondly, using highly advanced IC's with the help of growing technology, the project has been successfully implemented. Thus the project has been successfully designed and tested

### 6. FUTURE SCOPE

The main disadvantage of this project is that the person who is operating the appliances doesn't know the status of the DC motor. This drawback can be eliminated by introducing a GSM module, through which intimation on the status of DC motor can be sent from anywhere in the world.

- In future, apart from controlling the speed and direction of DC motors, the same technique can be



implemented in both single phase and three phase AC motors as well.

- For long range wireless communication WIFI-module can be used.
- Touch screen technology can also be implemented.

## 7. ACKNOWLEDGEMENT

We would like to thank all the authors of different research papers referred during writing this paper. It was very knowledge gaining and helpful for the further research to be done in future.

## 8. RESULTS

The project “**Speed and Direction control of a DC Motor using Android Mobile Application**” was designed to operate a DC motor using PWM and controlling through Bluetooth module and the system able to monitor the motor speed on LCD display. IR sensor is used to measure the RPM of DC motor. By using PWM signal we can control the DC motor.

## REFERENCES

1. Sunita, TirupatiGupta:Speed control of Single phase Induction motor using android bluetooth.ISSN-2321-3361 International Journal of Engineering Science and Computing Volume 6 Issue 5 September 2016.
2. Mr.K.Narasimhaiah:Speed Control of AC motor by using blue control app.ISSN-2393-9923 Global Journal of Trends in Engineering Volume 1 Issue 2 April-2016.
3. AbhishekGupta: Induction motor speed control using android application.ISSN-2348-6988 International Journal of Electrical and Electronic Research Volume 4 Issue 2 April-june 2016.
4. Salivahanan, S.Suresh, N., and Vallavaraj, A. “Electronic Devices and Circuit”, Fourth Edition, Tada Seventh Edition, 2000, McGraw-Hill Publishing Company Limited.
5. Modern Applied Science Vol 5, No 3 (2011). A Novel Approach to Analog Signal Isolation through Digital Optocoupler (YOUTUBE).
6. V.J. Sivanagappa, K.Haribalan “Speed control of DC motor via Internet for Traction Applications” IEEE, 2016.
7. Bhattacharjee, et al., “Speed Control of BLDC Motor through Mobile Application via Secured Bluetooth”, Recent Developments in Control, Automation and Power Engineering, Noida, India, May 2018.
8. N. Barsoum, “DC motor speed control using SMS application”, Journal of Intelligent Control and Automation, vol. 5, no. 4, pp. 205-212, 2014.