

Chief Editor

Dr. A. Singaraj, M.A., M.Phil., Ph.D.

Editor

Mrs.M.Josephin Immaculate Ruba

EDITORIAL ADVISORS

1. Prof. Dr.Said I.Shalaby, MD,Ph.D.
Professor & Vice President
Tropical Medicine,
Hepatology & Gastroenterology, NRC,
Academy of Scientific Research and Technology,
Cairo, Egypt.
2. Dr. Mussie T. Tessema,
Associate Professor,
Department of Business Administration,
Winona State University, MN,
United States of America,
3. Dr. Mengsteab Tesfayohannes,
Associate Professor,
Department of Management,
Sigmund Weis School of Business,
Susquehanna University,
Selinsgrove, PENN,
United States of America,
4. Dr. Ahmed Sebihi
Associate Professor
Islamic Culture and Social Sciences (ICSS),
Department of General Education (DGE),
Gulf Medical University (GMU),
UAE.
5. Dr. Anne Maduka,
Assistant Professor,
Department of Economics,
Anambra State University,
Igbariam Campus,
Nigeria.
6. Dr. D.K. Awasthi, M.Sc., Ph.D.
Associate Professor
Department of Chemistry,
Sri J.N.P.G. College,
Charbagh, Lucknow,
Uttar Pradesh. India
7. Dr. Tirtharaj Bhoi, M.A, Ph.D,
Assistant Professor,
School of Social Science,
University of Jammu,
Jammu, Jammu & Kashmir, India.
8. Dr. Pradeep Kumar Choudhury,
Assistant Professor,
Institute for Studies in Industrial Development,
An ICSSR Research Institute,
New Delhi- 110070, India.
9. Dr. Gyanendra Awasthi, M.Sc., Ph.D., NET
Associate Professor & HOD
Department of Biochemistry,
Dolphin (PG) Institute of Biomedical & Natural
Sciences,
Dehradun, Uttarakhand, India.
10. Dr. C. Satapathy,
Director,
Amity Humanity Foundation,
Amity Business School, Bhubaneswar,
Orissa, India.



ISSN (Online): 2455-7838

SJIF Impact Factor (2017): 5.705

EPRA International Journal of

Research & Development (IJRD)

Monthly Peer Reviewed & Indexed
International Online Journal

Volume: 3, Issue:9, September 2018



Published By :
EPRA Journals

CC License





DIGITAL NOTICE BOARD AND ITS APPLICATION IN EDUCATIONAL INSTITUTIONS

Sreeram V

Alumni, CUSAT, College of Engineering Adoor, Kollam, Kerala, India

ABSTRACT

In most of the colleges the academics' information's are usually displayed on a notice board. For this purpose papers are excessively used which in its own way contributes for environmental destruction and also in every educational institution there is delay in the availability of data's of students from the faculty. In the absence of the faculty the availability of data for quick reference is difficult. For solving these problems and to be a part of paper free campuses and reducing work load among staffs, this research paper is to introduce a digital notice and its applications like displaying all the information's about the students that can be accessed anytime.

In this proposed digital notice board data's are arranged in an organized manner for quick reference. The notice board hardware part mainly consists of a code composer studio known as Tiva C Series Launch pad. This launch pad have provisions for interfacing various circuits like SD card circuit, USB port, RF receiver, Keypad and digital LCD display. Necessary working voltage is provided to various circuits by means of power supply units. This notice board provides an effective link between students and teachers. It also provides the general information's that the teachers want to convey to the students easily.

KEYWORDS: *Digital notice board, Educational Institutions, Wireless notice board*

1. INTRODUCTION

The research paper aims to introduce a Digital Notice Board in educational institutions, which is to provide all the academic details of the students for quick reference. Our traditional notice board system in educational institutions consumes a large amount of paper and, almost all electronic notice boards are designed using wired system. One of the drawbacks of this system is its inflexible nature in term of placement. The common Electronic notice board cannot be placed anywhere because of the messy wiring and here the data's can't be updated frequently. The pro-posed one is a wireless notice board that can be placed anywhere and frequently updated in order to display the latest information. It works with a simple Personal Computer key board which can be used for entering data input and the entered input can be displayed on the LCD screen. The data's can be sent from the PC to display through RF transmitter and receiver. This Wireless Electronic Notice Board can be used in colleges and schools to display notifications, exam details and extra activities.

2. CURRENT SCENARIO

The old archaic model of paper notice board is used widely in most of the educational institutions. It needs a large number of workforce to maintain all these paper aspects before and after use. The storage mechanisms too need some kind of physical space availability and so the old file recovery will

become more and more complex. On the other hand, the ecological impact due to this kind of paper use remains a concern to all.

Some institutions are using electronic digital boards, but the messy wiring and the data up-dating complexity ruins the attractive nature of this product. The advancement in the embedded technology has been untouched for a while to upgrade the common electronic notice board. The data transfer option is unavailable and so the uses of this notice board are limited. Certain kinds of Wireless electronic notice board using GSM technology developed as user-friendly notice board with wireless concept that offers the flexibility to control the notice board within range of GSM Communication System. This system reduces the messy wiring of earlier electronic wired model. But the proposed system cannot be used for large text characters. GSM technology will make some unexpected delay in sending data too.

3. PROPOSED INNOVATION

The instant information updates and the RF modules have the capability to form a mesh net-work by which we can send larger data. Also, by using RF transmitter and receiver, avoid the unexpected delay in sending data. To make it friendlier the data's which is displayed will be copied to external device by pressing one button.

4. BLOCK DIAGRAM & DESCRIPTION

The basic block diagram of digital notice board consist of power supply, key pad interface, external storage, VGA converter, USB input, TTL converter, TivaC launch pad and LCD display. This chapter provides an overview about the proposed system. A brief description on various blocks is provided.

4.1. Power Supply Pressman et al. (2009)

Power supply is essential for the operation of micro controller and LCD display. Power supply consists of a step down transformer, bridge rectifier, capacitors and voltage regulators. Here 5V and 3.3V power supplies are used. 5V power supply is used for RF transmitter and receiver. 3.3V power supply is used for the Tiva C launch pad. To obtain 5V power supply the output of the transformer is fed to a bridge rectifier (DF10M) which is further fed to the input of a 5V regulator (7805). The output of 7805 voltage regulators is a constant 5V DC voltage. Similarly, 3.3V output is obtained by connecting the output of the bridge rectifier to a voltage regulator (LM317).

4.2. VGA Converter

A Video graphic array (VGA) connector is a three-row 15-pin DE- 15 connectors. The 15-pin VGA connector is found on many video cards, computer monitors, and high definition television sets. On laptop computers or other small devices, a mini-VGA port is sometimes used in place of the full-sized VGA connector. VGA connectors and cables carry analog

component RGBHV (red, green, blue, horizontal sync, vertical sync video signals), and VESA Display Data Channel (VESA DDC) data. In the original version of DE-15 pin out, one pin was keyed by plugging the female connector hole; this prevents non-VGA 15 pin cables from being plugged into a VGA socket.

Four pins carried Monitor ID bits which were rarely used; VESA DDC redefined some of these pins and replaced the key pin with +5 V0 DC power supply. The VGA interface is not engineered to be hot pluggable (so that the user can connect or disconnect the output device while the host is running), although in practice this can be done and usually does not cause damage to the hardware or other problems. However, nothing in the design ensures that the ground pins make a connection first and break last, so hot plugging may introduce surges in signal lines which may or may not be adequately protected against. Also, depending on the hardware and software, a monitor being connected might not work properly in all cases.

4.3. External Storage

External storage comprises devices that temporarily store information for transporting from computer to computer. Such devices are not permanently fixed inside a computer. Semiconductor memories are not sufficient to provide the whole storage capacity required in computers. The major limitation in using semiconductor memories is

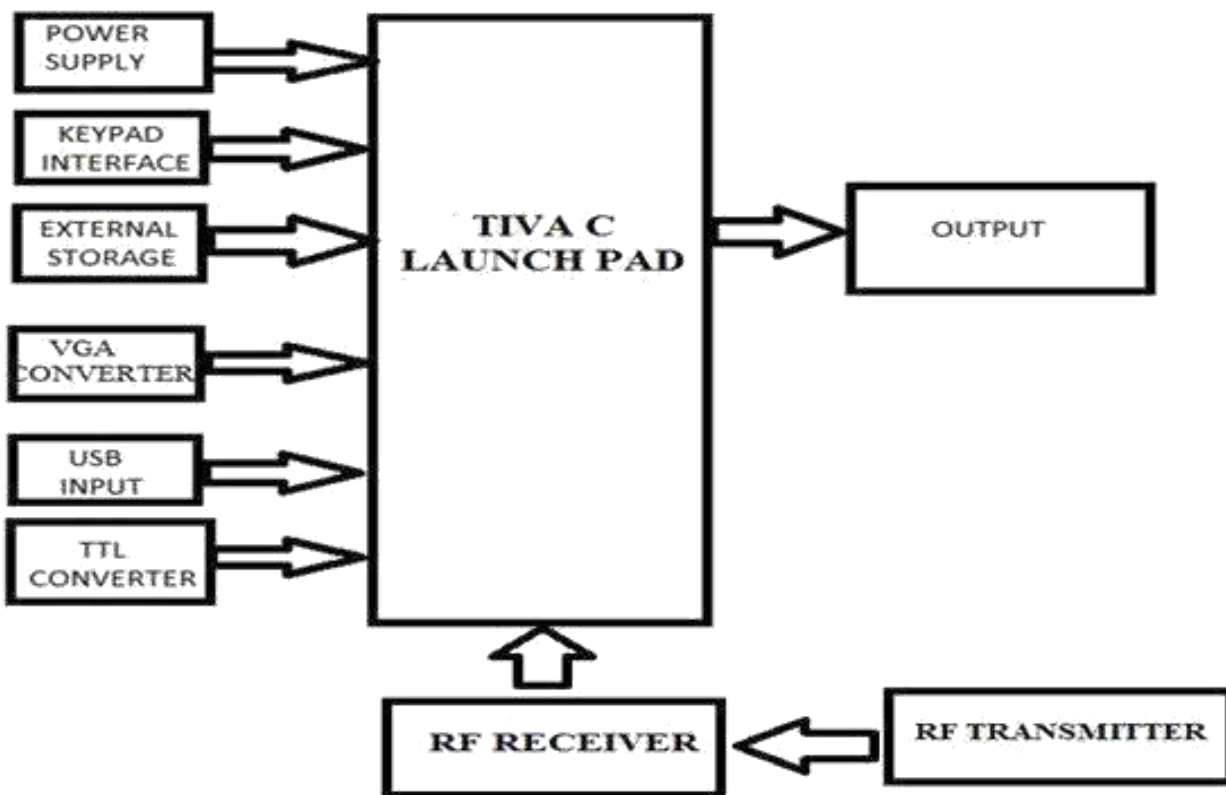

Figure 1: Block Diagram

the cost per bit of the stored information. So to fulfill the large storage requirements of computers, magnetic disks and optical disks are generally used. External storage devices provide additional storage other than that available in computer. Data can be transported easily from one place to another. External storage also works as data backup. This back up may prove useful at times such as fire or theft because important data is not lost.

4.3.1. Memory Card

A memory card (sometimes called a flash memory card or a storage card) is a small storage medium used to store data such as text, pictures, audio, and video, for use on small, portable or remote computing devices. Most of the current products use flash memory, although other technologies are being developed. There are a number of memory cards on the market, including the SD card (secure digital card), the CF card (Compact Flash card), the Smart Media card, the Memory Stick, and the Multi Media Card (MMC). These cards are of varying sizes, and each is available in a range of storage capacities that typically corresponds directly to the price. The Compact Flash card is about the size of a matchbook, while the Multi Media Card and Secure Digital card are each about the size of a postage stamp. Most available cards have constantly powered non-volatile memory, which means that data is stable on the card, is not threatened by a loss of power source, and does not need to be periodically refreshed. Because memory cards are solid state media, they have no moving parts, and therefore, are unlikely to suffer mechanical difficulties. Earlier removable storage media, such as the PC card, the smart card, and similar cards used for game systems, can also be considered to be memory cards. However, the newer cards are smaller, require less power, have higher storage capacity, and are portable among a greater number of devices. Because of these features, memory cards are influencing the production of an increasing number of small, lightweight and low-power devices. Memory cards offer a number of advantages over the hard disk drive: they're much smaller and lighter, extremely portable, completely silent, allow more immediate access, and are less prone to mechanical damage. In comparison, however, the hard disk still offers a compelling advantage: currently, a memory card (for example, Compact Flash) with a 192MB capacity typically costs more than a hard drive with a capacity of 40 GB.

4.4. USB Port

A USB port is a standard cable connection interface on personal computers and consumer electronics. USB ports allow stand-alone electronic devices to be connected via cables to a computer (or to each other). USB stands for Universal Serial Bus, an industry standard for short distance digital data communications. USB allows data to be transferred between devices. USB ports can also supply electric power across the cable to devices without their own power source. Both wired and wireless versions of the USB standard exist, although only the wired version involves USB ports and cables for computer-to-computer file transfers without a network, USB keys are also sometimes used to copy files between devices. Multiple USB devices can also be connected to each other using a USB hub.

4.5. Transistor-Transistor Logic (TTL) Converter

Transistor-transistor logic (TTL) is a class of digital circuits built from bipolar junction transistors (BJT) and resistors. It is called transistor-transistor logic because both the logic gating

function (eg, AND) and the amplifying function are performed by transistors (contrast with resistor-transistor logic (RTL) and diode-transistor logic (DTL)). TTL is notable for being a widespread integrated circuit (IC) family used in many applications such as computers, industrial controls, test equipment and instrumentation, consumer electronics, synthesizers, etc. The designation TTL is sometimes used to mean TTL compatible logic levels, even when not associated directly with TTL integrated circuits, for example as a label on the inputs and outputs of electronic instruments. TTL manufacturers offered a wide range of logic gate, flip-flops, counters, and other circuits. Several variations of the original bipolar TTL concept were developed, yielding circuits with higher speed or lower power dissipation to allow optimization of a design. TTL circuits simplified system design compared to earlier logic families, offering speed superior to RTL. The design of the input and outputs of TTL gates allowed many elements to be interconnected. TTL became the foundation of computers and other digital electronics. Even after much larger scale integrated circuits made multiple-circuit board processors obsolete, TTL devices still found extensive use as the "glue" logic interfacing more densely integrated components. TTL devices were originally made in ceramic and plastic dual-in-line (DIP) packages, and flat-pack form. TTL chips are now also made in surface-mount packages. Successors to the original bipolar TTL logic are often interchangeable in function with the original circuits, but with improved speed or lower power dissipation. TTL inputs are the emitters of a multiple-emitter transistor. This IC structure is functionally equivalent to multiple transistors where the bases and collectors are tied together. The output is buffered by a common emitter amplifier.

4.5.1. Inputs both logical ones

When all the inputs are held at high voltage, the base-emitter junctions of the multiple-emitter transistor are reverse-biased. Unlike DTL, a small "collector" current (approximately 10 A) is drawn by each of the inputs. This is because the transistor is in reverse-active mode. An approximately constant current flows from the positive rail, through the resistor and into the base of the multiple emitter transistors. This current passes through the base-emitter junction of the output transistor, allowing it to conduct and pulling the output voltage low (logical zero).

4.5.2. An input logical zero

Note that the base-collector junction of the multiple-emitter transistor and the base-emitter junction of the output transistor are in series between the bottom of the resistor and ground. If one input voltage becomes zero, the corresponding base-emitter junction of the multiple-emitter transistor is in parallel with these two junctions. A phenomenon called current steering means that when two voltage-stable elements with different threshold voltages are connected in parallel, the current flows through the path with the smaller threshold voltage.

That is, current flows out of this input and into the zero (low) voltage sources. As a result, no current flows through the base of the output transistor, causing it to stop conducting and the output voltage becomes high (logical one). During the transition the input transistor is briefly in its active region; so it draws a large current away from the base of the output transistor and thus quickly discharges its base. This is a critical advantage of TTL over DTL that speeds up the transition over a diode input structure. The main disadvantage

of TTL with a simple output stage is the relatively high output resistance at output logical "1" that is completely determined by the output collector resistor. It limits the number of inputs that can be connected (the fan out). Some advantage of the simple output stage is the high voltage level (up to VCC) of the output logical "1" when the output is not loaded.

4.6. TIVA C Series Launch Pad (TM4C123GH6PMI)

The Tiva™ C Series TM4C123G Launch-Pad Evaluation Board (EKTM4C123GXL) is a low-cost evaluation platform for ARM® Cortex™-M4Fbased micro controllers. The Tiva C Series Launch Pad design highlights the TM4C123GH6PMI micro controller USB 2.0 de-vice interface, hibernation module, and motion control pulse-width modulator (MC PWM) module. The Tiva C Series LaunchPad also features programmable user buttons and an RGB LED for custom applications. The stack able headers of the Tiva C Series TM4C123G LaunchPad Boost-erPack XL interface demonstrate how easy it is to expand the functionality of the Tiva C Series LaunchPad when interfacing to other peripherals on many existing Booster Pack add-on boards as well as future products. Offering quicker time-to-market and cost savings, the Tiva™ C Series micro controllers are the leading choice in high-performance 32-bit applications. The Tiva™ C Series ARM Cortex-M4 micro controllers provide top performance and advanced integration.

4.7. RF Transmitter and Receiver

The RF module, as the name suggests, operates at Radio Frequency. The corresponding frequency range varies between 30 kHz & 300 GHz. In this RF system, the digital data is represented as variations in the amplitude of carrier wave. This kind of modulation is known as Amplitude Shift Keying (ASK). Transmission through RF is better than IR (infrared) because of many reasons. Firstly, signals through RF can travel through larger distances making it suitable for long range applications. Also, while IR mostly operates in line-of sight mode, RF signals can travel even when there is an obstruction between transmitter & receiver. Next, RF transmission is more strong and reliable than IR transmission. RF communication uses a specific frequency unlike IR signals which are affected by other IR emitting sources. This RF module consists of an RF Transmitter and an RF Receiver. The transmitter/receiver (Tx/Rx) pair operates at a frequency of 434 MHz. An RF transmitter receives serial data and transmits it wirelessly through RF through its antenna connected at pin4. The transmission occurs at the rate of 1Kbps - 10Kbps. The transmitted data is received by an RF receiver operating at the same frequency as that of the transmitter.

4.8. Keypad Interface

Keypad interface consists of set of alpha- numeric keys i.e., 0-9,A,B,C...etc. It acts as an inter-face between the user and display. Here it is used as a medium for selecting options on the screen for the user thus increasing accessibility.

4.9. LCD Display

LCD (liquid crystal display) is the technology used for displays in notebook and other smaller computers. Like light-emitting diode (LED) and gas plasma technologies, LCDs allow displays to be much thinner than cathode ray tube (CRT) technology. LCDs consume much less power than LED and gas display displays because they work on the principle of blocking light rather than emit-ting it.

An LCD is made with either a passive matrix or an active matrix display grid. The active matrix LCD is also known as a thin film transistor (TFT) display. The passive matrix LCD has a grid of conductors with pixels located at each intersection in the grid. A current is sent across two conductors on the grid to control the light for any pixel. An active matrix has a transistor located at each pixel intersection, requiring less current to control the luminance of a pixel. For this reason, the current in an active matrix display can be switched on and off more frequently, improving the screen refresh time. Some passive matrix LCD's have dual scanning, meaning that they scan the grid twice with current in the same time that it took for one scan in the original technology. However, active matrix is still a superior technology

5. CIRCUIT DESCRIPTION AND DE-SIGN

The hardware design and description of the circuits are detailed here. The working voltage for RF transmitter-receiver, Tiva C launch pad, etc is provided through a power supply module. It consists of a 12-0-12 step-down transformer, DF10M bridge rectifier, capacitor filter network and voltage regulator 7805 and LM 317. The out-put of 7805 regulators is a constant 5V dc which is fed to the RF module. The output of LM 317 is 3.3V which is fed to the micro controller in the launch pad. The LCD screen is fed with a direct 230V, 50Hz supply.

The data to be displayed is initially created in MS-Excel format and saved in a predefined for-mat in the master personal computer. This master computer is equipped with an RF transmitter which transmits the file to the RF receiver connected to the launch pad. The transferred file is stored in an external storage device. This storage device is interfaced with the display such that se-lect input through a keypad interface displays the required data on the screen. A USB port is pro-vided so that users can collect necessary files from the external storage by just pressing “ * ” sign on the keypad. A specific time delay is also provided such that the selection screen returns to default screen if selections are not made within a specific time. The display which is developed can be easily accessed and operated by anyone, thus making it user-friendly.

5.1.

5.1.1. Design of Components

The design of various components used in the circuit is discussed below.7805 Voltage Regulator. It is used to get a constant 5V supply for the RF transmitter and receiver. Input voltage range is 4.8-5.2V. Desired output of the power supply is 5V. Hence, LM 7805 regulators is selected for this purpose. Hence, 12V output transformer is selected.

LM 317 Voltage Regulator. It is used to get constant 3.3V supply for the micro controller in the Tiva C launch pad. Its output voltage range is 1.25V - 37V. Desired output can be obtained by providing a variable resistor.

Transformer. Transformer is a device which converts high voltage supply to low voltage value or vice versa. The input range of the LM 7805 regulators is 7-25V and for LM 317 it is 3-40v. Hence, 12V output transformer is selected. The input of the transformer is supplied from 230V main supply. The circuit has a power rating of 1A. Hence, a 230/0-12V, 1A step down transformer is used in the power supply.

Capacitor. The capacitor is used to filter out the ripples in the dc output of rectifier. The capacitor value is selected so that the ripple content in the output dc voltage is limited to

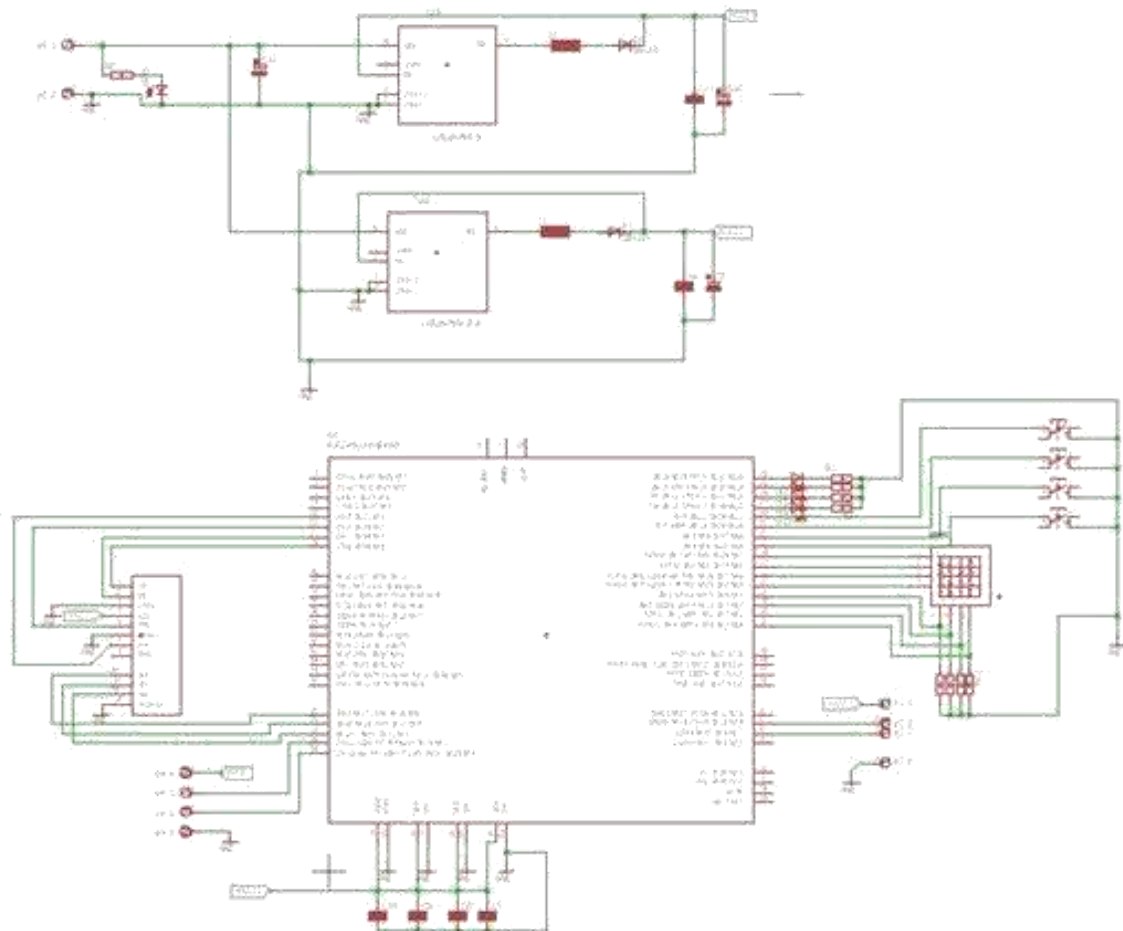

Figure 3: Circuit diagram for storing & transmitting data

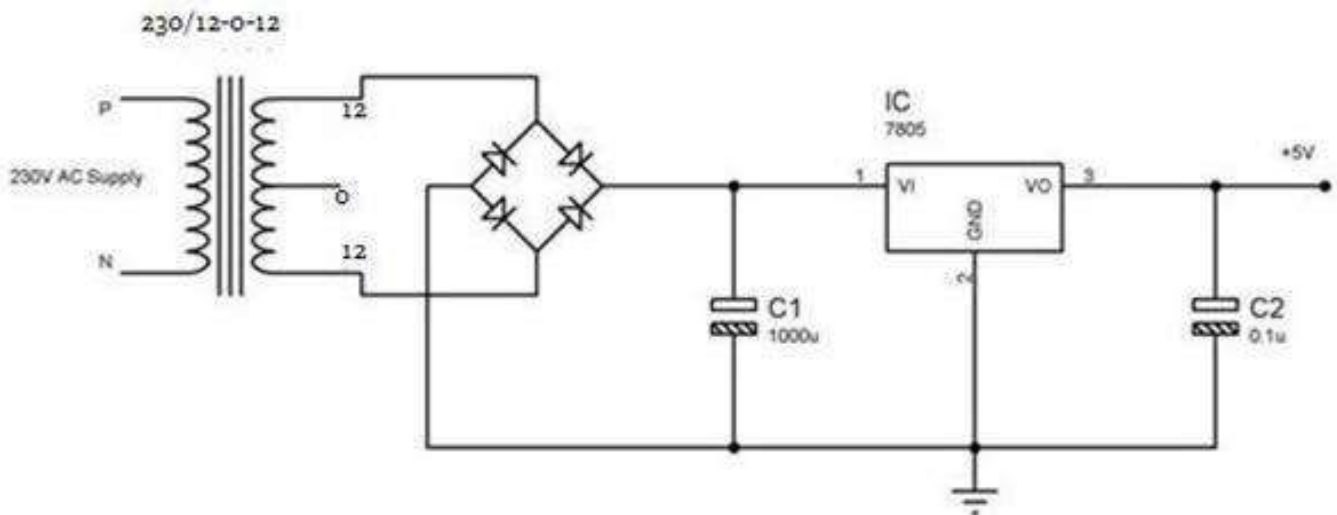

Figure 4: 5V Power supply

6.2. Transformer

Transformer is a static ac machine that transfers electrical energy from one circuit to another without change in frequency by the principle of electromagnetic induction. It can raise or lower the voltage in a circuit but with a corresponding decrease or increase in current. The physical ba-sis of a transformer is mutual induction

between two-circuits linked by a common magnetic flux. In its simplest form it consists of two inductive coils which are electrically separated but magnetically linked through a path of low reluctance.

The two coils possess high mutual inductance. If one coil is connected to a source of alternating voltage, an alternating flux is set up in the laminated core most of

which is linked with the other coil in which it produces mutually-induced e.m.f. (according to Faraday's Law of Electromagnetic Induction). If the second coil circuit is closed, a current flows in it and so electric energy is transferred (entirely magnetically) from first coil to the second coil. The first coil, in which electric energy is fed from the a.c. supply mains, is called primary winding and the other from which energy is drawn out is called secondary winding. Except for air-core transformers, the coils are commonly wound around a single iron-rich core, or around separate but magnetically-coupled cores. Voltage may be stepped up or down depending on the design of the primary and secondary winding.

6.3. Bridge Rectifier

In the bridge circuit, four diodes are connected in the form of a Wheatstone bridge, two diametrically opposite junctions of the bridge are connected to the secondary of a transformer and the other two are connected to the load. When the upper end of the transformer secondary winding is positive, say during first half cycle of the input supply, diodes D1 and D3 are forward biased and current flows through the load. During this half of each input cycle diodes D2 and D4 are reverse biased. In the second half of input cycle the lower end of ac supply become positive, diodes D2 and D4 are forward biased and current flows through the load. The direction of load current remains the same during both half cycle of the input supply voltage. This circuit not only produces a DC output from an AC input, but also provides what is sometimes called "reverse polarity protection". Here a DF10M bridge rectifier is used.

6.4. Capacitor Filter Gupta (2011)

Filtering is frequently effected by shunting the load with a capacitor. This is the simplest form of filter circuit. The action of this system depends upon the fact that the capacitor stores energy during the conduction period and delivers this energy to the load during the inverse, or non-conducting, period. In this way the time during which the current passes through the load is prolonged, and the ripple is considerably decreased.

6.5. 7805 Voltage Regulator

The 7805 is a family of self-contained fixed linear voltage regulator integrated circuits. The 7805 family is commonly used in electronic circuits requiring a regulated power supply due to their ease-of-use and low cost. For ICs within the family, the 7805 has a 5 volt output. The 7805 line are positive voltage regulators: they produce a voltage that is positive relative to a common ground. 7805 ICs have three terminals and are commonly found in the TO220 form factor, although smaller surface-mount and larger TO3 packages are available. These devices support an input voltage anywhere from a few volts over the intended output voltage, up to a maximum of 35 to 40 volts depending on the make, and typically provide 1 or 1.5 amperes of current (though smaller or larger packages may have a lower or higher current rating).

6.6. 3.3 V Power Supply

The 3.3V power supply consists of step-down transformer, 1N4007 diodes, LM317 voltage rectifier.

6.7. 1N4007 Diodes Millman et al. (2007)

The most common function of a diode is to allow an electric current to pass in one direction (called the diode's forward direction), while blocking current in the opposite direction (the reverse

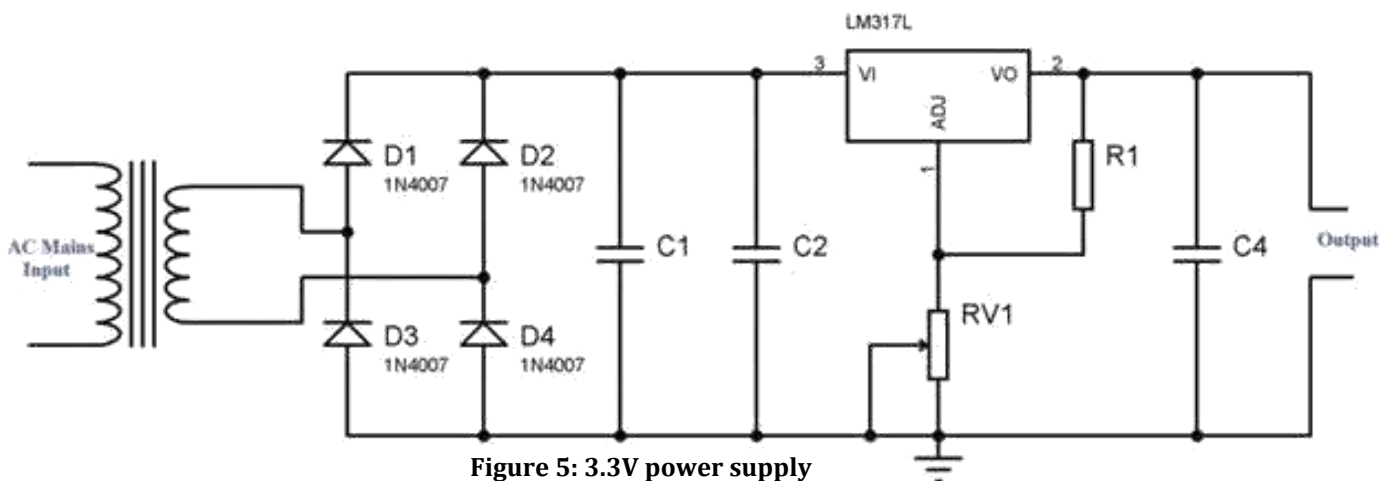

Figure 5: 3.3V power supply

direction). Thus, the diode can be viewed as an electronic version of a check valve. This unidirectional behavior is called rectification, and is used to convert alternating current to direct current, including extraction of modulation from radio signals in radio receivers—these diodes are forms of rectifiers. However, diodes can have more complicated behavior than this simple on–off action, due to their nonlinear current-voltage characteristics. Semiconductor diodes begin conducting electricity only if a certain threshold voltage or cut-in voltage is present in the forward direction (a state in which the diode is said to be forward-biased). The voltage drop across a forward-biased diode varies only a little with the current, and is a function of temperature; this effect can be used as a temperature sensor or as a voltage reference. A semiconductor diode’s current–voltage characteristic can be tailored by selecting the semiconductor materials and the doping impurities introduced into the materials during manufacture. These techniques are used to create special-purpose diodes that perform many different functions. For example, diodes are used to regulate voltage (Zener diodes), to protect circuits from high voltage surges (avalanche diodes), to electronically tune radio and TV receivers to generate radio-frequency oscillations (tunnel diodes, Gunn diodes, IMPATT diodes), and to produce light (light-emitting diodes). Tunnel, Gunn and IMPATT diodes exhibit negative resistance, which is useful in microwave and switching circuits. The 1N4001 series (or 1N4000 series) is a family of popular 1.0 A (ampere) general-purpose silicon rectifier diodes commonly used in AC adapters for common household appliances. Blocking voltage varies from 50 to 1000 volts.

6.8. LM 317 Voltage Regulator

The LM317 is a popular adjustable linear voltage regulator. As linear regulators, the LM317 and LM337 are used in DC to DC converter applications. Linear regulators inherently waste as much current as they supply. When this current is multiplied by the voltage difference between input and output, a significant amount of heat will result. Therefore, the use of an LM317 commonly also requires a heat sink. For large voltage differences, the energy lost as heat can ultimately be greater than that provided to the circuit. This is the trade-off for using linear regulators which are a simple way to provide a stable voltage with few additional components. The alternative is to use a switching voltage regulator which is usually more efficient but has a larger footprint and requires a larger number of associated components.

In packages with a heat-dissipating mounting tab, such as TO-220, the tab is connected internally to the output pin which may make it necessary to electrically isolate the tab or the heat sink from other parts of the application circuit. Failure to do this may cause the circuit to short. The LM317 has three pins: input, output, and adjustment. The device is conceptually an op amp with a relatively high output current capacity. The inverting input of the amp is the adjustment pin, while the non-inverting input is set by an internal band gap voltage reference which produces a stable reference voltage of 1.25 V. A resistive voltage divider between the output and ground configures the op amp as a non-inverting amplifier so that the voltage of the output pin is continuously adjusted to be a fixed amount, the reference voltage, above that of the adjustment pin. Ideally, this makes the output voltage:

$$V_{out} = V_{ref} (1 + (R_L / R_H))$$

Because some quiescent current flows from the adjustment pin of the device, an error term is added:

$$V_{out} = V_{ref} (1 + (R_L / R_H)) + I_{QRL}$$

To make the output more stable, the device is designed to keep the quiescent current at or below 100 A, making it possible to ignore the error term in nearly all practical cases.

7. SD CARD READER

The circuit configuration of SD card reader is shown in Fig 6

7.1. SD Card

A standard SD card can be operated in two modes. They are the SD bus mode and the SPI bus mode. SD bus mode is the native operating mode of the card and all the pins are used in this mode. Data is transferred using four pins (D0- D3), a clock (CLK) pin and a command line (CMD). Data can be transferred from the card to the host or vice versa over the four data lines. SPI mode is the more commonly used mode, and it allows data to be transferred on two lines (D0 and D1) in serial format using a chip select CS and a CLK line. The SPI mode is easier to use, but it has the disadvantage of reduced performance compared with the SD mode of operation. SD card pins have different meanings depending upon the mode of operation.

7.2. SD Card Interface

Before we can use an SD card in an electronic circuit, we have to know the interface signal levels. SD cards support hot insertion of the card, i.e, the card can be inserted into the circuit without powering down the host. This is usually achieved through the card connector. Connector manufacturers usually provide sockets that have power pins long enough to power the card before any contact is made with the other pins.

A feature of most SD cards is the automatic entry and exit from sleep mode. After an operation, cards usually enter a sleep mode to conserve power-in, if no more commands are received within 5ms. Although the host does not need to do anything for this to happen, it is recommended that the host shut the clock generation. Any command sent to the card will force it to exit from the sleep mode. SD cards can consume up to 100-200 mA while reading or writing onto the card. This is usually a high current, and an appropriate voltage regulator capable of supplying the required current must be used in the design. The card consumes approximately 150 micro amperes in sleep mode.

7.3. Data Read

Data can be read in single or multiple blocks, the basic unit of data size is blocks, defined by field READ_BLOCK_LEN of the CSD register. Single block reads are initiated by issuing the command READ_SINGLE_BLOCK (CMD17) to the card. Any valid address can be used as the starting address.

7.4. Data Write

Data can be written in either single or multiple blocks. After receiving a valid write command, the card sends a response token and then waits for the data block to be sent from the host. The starting address can be any valid address. After receiving a data block from the host, the card returns a data response token and writes the data on the card if the data contains no errors. There are a large number of commands available in SPI mode for reading the card registers, reading and

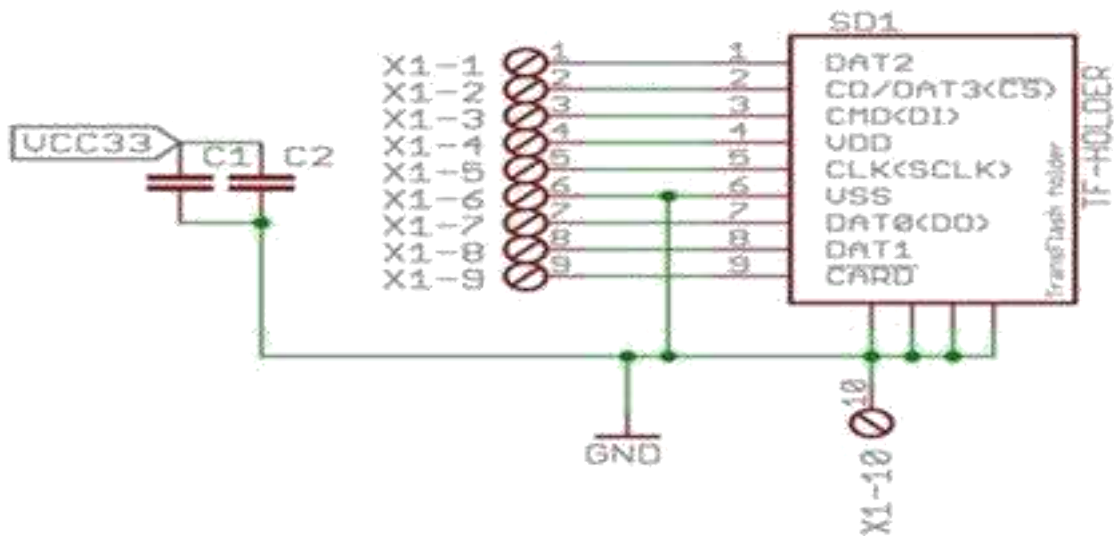

Figure 6: SD card reader circuit

writing single and multiple blocks of data erasing blocks, etc. All SPI mode commands are 6 bytes long (48 bits). The commands start with the most significant bit (MSB) as logic 0, a trans-mission bit as logic 1, 6 bits of command index, 32 bits of argument (not all commands need arguments), 7bits of CRC, and an end bit (logic 1). The commands are divided into classes. If no argument is required in a command, the value of the argument field should be all “0”s. The command index contains the actual command number. For example, the command index value for command CMD8 is binary number 8 in 6bits.

8. TIVA C SERIES LAUNCH PAD

The advantages and features of the Tiva C launch pad are discussed in detail here.

8.1. Architectural Overview

Texas Instrument’s Tiva™ C Series micro controllers provide designers a high-performance ARM® Cortex™-M-based architecture with a broad set of integration capabilities and a strong ecosystem of software and development tools. Targeting performance and flexibility, the Tiva™ C Series architecture offers a 80 MHz Cortex-M with FPU, a variety of integrated memories and multiple programmable GPIO. Tiva™ C Series devices offer consumers compelling cost effective solutions by integrating application-specific peripherals and providing a comprehensive library of software tools which minimize board costs and de-sign cycle time. Offering quicker time-to-market and cost savings, the Tiva™ C Series micro controllers are the leading choice in high-performance 32-bit applications. The Tiva™ C Series ARM Cortex-M4 micro controllers provide top performance and advanced integration. The product family is positioned for cost-conscious applications requiring significant control processing and connectivity capabilities such as:

- Low power, hand-held smart devices
- Gaming equipment
- Home and commercial site monitoring and control
- Motion control

- Medical instrumentation
- Test and measurement equipment
- Transportation

For applications requiring extreme conservation of power, the TM4C123GH6PM micro controller features a battery-backed Hibernation module to efficient power down the TM4C123GH6PM to a low-power state during extended periods of inactivity. With a power-up/power-down sequencer, a real time counter (RTC), multiple wake-from-hibernate options, and dedicated battery backed memory, the Hibernation module positions the TM4C123GH6PM micro controller perfectly for battery applications. In addition, the TM4C123GH6PM micro controller [5] offers the advantages of ARM’s widely available development tools, System on-Chip (SoC) infrastructure IP applications, and a large user community. Additionally, the micro controller uses ARM’s Thumb®-compatible Thumb-2 instruction set to reduce memory requirements and, thereby, cost. Finally, much of the TM4C123GH6PM micro controller code is compatible to the Tiva™ C Series product line, providing flexibility across designs.

8.2. Features

Tiva C Series LaunchPad includes the following features:

- Tiva TM4C123GH6PMI micro controller Motion control PWM
- USB micro-A and micro-B connector for USB device, host, and onthego (OTG) connectivity
- RGB user LED
- Two user switches (application/wake)
- Available I/O brought out to headers on a 0.1-in (2.54-mm) grid On-board ICDI
- Switch-selectable power sources Reset switch
- Preloaded RGB quick start application
- Supported by TivaWare for C Series soft-ware including the USB library and the peripheral driver library
- Tiva C Series TM4C123G Launch Pad Booster Pack XL Interface, which features stack-able headers to

expand the capabilities of the Tiva C Series Launch Pad development platform.

9. SOFTWARE DESCRIPTION

Software development is an important factor for programming a Tiva C launch pad. The algorithm for developing the software is described in the following sections.

9.1. Algorithm

Algorithm is the method of writing the step by step instruction of the solution of a problem using any human language. It is a procedure or formulae for solving a problem and it aids in easier understanding of a program. The algorithm of the program is given below:

Step 1: Declare variables

Step 2: Menu selection

Step 3: File open, file display

Step 4: Check key for scroll option

Step 5: Select Copy or save button

Step 6: If yes store content to sd card

Step 7: Check timer for particular interval after that display default screen

9.2. Software Requirements

The software which used in this project is Energia

9.2.1. Energia

Energia is an open-source electronics prototyping platform started with the goal to bring the Wiring and Arduino framework to the Texas Instruments MSP430 based LaunchPad. The Energia IDE is cross platform and supported on Mac OS, Windows, and Linux. Energia uses the mspgcc compiler and is based on the Wiring and Arduino framework. Energia includes an integrated development environment (IDE) that is based on processing. Energia is also a portable framework/abstraction layer that can be used in other popular IDEs. Utilize a web browser based environment with CCS Cloud . Community maintained Energia plug-ins and integrations are available for Xcode, Visual Studio and Code Composer Studio. Energia started out to bring the Wiring and Arduino framework to the Texas Instruments MSP430 LaunchPad. Texas Instruments offers a MSP430, MSP432, TM4C, C2000 and CC3200 LaunchPad. The LaunchPad is a low-cost micro controller board that is made by Texas Instruments. Additional community kits are also supported. Together with Energia, LaunchPad can be used to develop interactive objects, taking inputs from a variety of switches or sensors, and controlling a variety of lights, motors, and other physical outputs. LaunchPad projects can be stand-alone, or they can communicate with software running on computer (Host PC). It can also add wireless modules to enable communication over various types of RF including Wi-Fi, NFC, Bluetooth, Zigbee, cellular, and more.

10. CONCLUSION

The proposed digital notice board will display the student's details for quick reference. As paper consumption can be eliminated here, this project in another way contributes for environmental protection. The severe work loads among staffs have been minimized as the students can readily access their academic details from the display without the help from the faculty. The projected device is user-friendly, reliable and can be managed easily. As each file to be displayed is of small size an external storage up to 4GB would be sufficient for storing details of several batches. Further development can be done in the system by providing a backup power supply, if by any means the main supply fails. Future works in the device can allow transmission of any file formats.

REFERENCES

1. Gupta, J. (2011). *Electronic devices and circuits*. S.K. Kataria & Sons, New Delhi.
2. Millman, J., Halkias, C. J., and S. (2007). *Electronic devices and circuits*. McGraw Hill Higher Education, New Delhi: Tata.
3. Pressman, A., Billings, K. M., and T. (2009). *Switching power supply design*. MCGraw-Hill, New York.