

### Chief Editor

Dr. A. Singaraj, M.A., M.Phil., Ph.D.

### Editor

Mrs.M.Josephin Immaculate Ruba

### EDITORIAL ADVISORS

1. Prof. Dr.Said I.Shalaby, MD,Ph.D.  
Professor & Vice President  
Tropical Medicine,  
Hepatology & Gastroenterology, NRC,  
Academy of Scientific Research and Technology,  
Cairo, Egypt.
2. Dr. Mussie T. Tessema,  
Associate Professor,  
Department of Business Administration,  
Winona State University, MN,  
United States of America,
3. Dr. Mengsteab Tesfayohannes,  
Associate Professor,  
Department of Management,  
Sigmund Weis School of Business,  
Susquehanna University,  
Selinsgrove, PENN,  
United States of America,
4. Dr. Ahmed Sebihi  
Associate Professor  
Islamic Culture and Social Sciences (ICSS),  
Department of General Education (DGE),  
Gulf Medical University (GMU),  
UAE.
5. Dr. Anne Maduka,  
Assistant Professor,  
Department of Economics,  
Anambra State University,  
Igbariam Campus,  
Nigeria.
6. Dr. D.K. Awasthi, M.Sc., Ph.D.  
Associate Professor  
Department of Chemistry,  
Sri J.N.P.G. College,  
Charbagh, Lucknow,  
Uttar Pradesh. India
7. Dr. Tirtharaj Bhoi, M.A, Ph.D,  
Assistant Professor,  
School of Social Science,  
University of Jammu,  
Jammu, Jammu & Kashmir, India.
8. Dr. Pradeep Kumar Choudhury,  
Assistant Professor,  
Institute for Studies in Industrial Development,  
An ICSSR Research Institute,  
New Delhi- 110070, India.
9. Dr. Gyanendra Awasthi, M.Sc., Ph.D., NET  
Associate Professor & HOD  
Department of Biochemistry,  
Dolphin (PG) Institute of Biomedical & Natural  
Sciences,  
Dehradun, Uttarakhand, India.
10. Dr. C. Satapathy,  
Director,  
Amity Humanity Foundation,  
Amity Business School, Bhubaneswar,  
Orissa, India.



ISSN (Online): 2455-7838

SJIF Impact Factor : 6.093

EPRA International Journal of

# Research & Development (IJRD)

Monthly Peer Reviewed & Indexed  
International Online Journal

Volume: 4, Issue:1, January 2019



Published By  
EPRA Publishing

CC License





# SPEED CONTROL & POWER FACTOR CORRECTION OF BLDC MOTOR DRIVE FED BY ZETA CONVERTER

**B Srikanth<sup>1</sup>**

<sup>1</sup>Asst.Professor, Department of EEE, AITAM Engineering College (Autonomous), Tekkali, Andhrapradesh, India

**M Bhaskara Rao<sup>2</sup>**

<sup>2</sup>Asst.Professor, Department of EEE, AITAM Engineering College (Autonomous), Tekkali, Andhrapradesh, India

**V V Appalanaidu<sup>3</sup>**

<sup>3</sup>Asst.Professor, Department of EEE, AITAM Engineering College (Autonomous), Tekkali, Andhrapradesh, India

## ABSTRACT

*This paper proposes a brushless dc (BLDC) motor fed by zeta converter for power factor correction (PFC). A single phase supply followed by an uncontrolled bridge rectifier and a Zeta DC-DC converter is used to control the voltage of a DC link capacitor. The PFC-based zeta converter is designed to operate in discontinuous inductor current mode thus utilizing a voltage follower approach which requires a single voltage sensor for DC link voltage control and PFC operation. The speed variation in the BLDC motor is achieved by varying the DC link voltage. The DC link voltage is calculated corresponding to the duty cycle of the converter switch. The proposed drive with zeta converter is realized as an efficient method for power factor correction in low-power applications also. A MATLAB/Simulink is used to simulate the developed model to achieve the range of speed control with high power factor and improved Power Quality at the supply.*

**KEYWORDS:** Brushless DC motor (BLDCM), DC link voltage, PID controller, PFC (Power Factor Correction), Zeta converter.

## 1. INTRODUCTION

Brushless DC motor (BLDCM) is well suited in large number of applications. Due to its higher in efficiency, reliability, and torque and lower in noise level, maintenance requirements, electromagnetic interference (EMI) and of long life time. It is also named as electronically commutated motor. Since it has no brushes and commutator, rather an electronic commutation through VSI is used with switching sequence of VSI's switches depending up on the rotor position as sensed by Hall Effect position sensors. This motor is a trapezoidal back-EMF motor which has permanent magnets on the rotor and three phase windings on the stator. Brushed DC motor is increasingly being used in military, industrial and commercial applications. To provide a regulated output dc voltage in power systems, a DC/DC converter is

being used. There are four main types of converters, usually called the Buck, Boost, Buck-Boost and cuk converter. CUK, SEPIC and Zeta converters are the new classes of DC-DC converters. Among them, Zeta converter is the proposed in this paper. The proposed PFC-based zeta converter feeds a BLDC motor drive. The speed of BLDC motor is being controlled by varying the dc-link voltage of VSI. The PFC zeta converter acts as an inherent PF corrector as it is designed to operate in DICM. A Single voltage sensor is used to realize the complete operation of BLDCM. To reduce the switching losses an electronic commutation of BLDC motor is used. [1]

## 2. MATHEMATICAL MODEL OF BLDC MOTOR DRIVE SYSTEM

A 3 phase - Y connected trapezoidal back-EMF type BLDC is modeled. Trapezoidal back-EMF is referring that mutual inductance between stator and rotor has trapezoidal shape. Therefore a b c phase variable model is more applicable than d-q axis. With the intention of simplifying equations and overall model the following assumptions are made:

- Magnetic circuit saturation is ignored.
- Stator resistance, self and mutual inductance of all phases are equal and constant.
- Hysteresis and eddy current losses are eliminated.
- All semiconductor switches are ideal.

The electrical and mechanical mathematical equations of

BLDC are:

Voltage equations of each phase of BLDC motor

$$= + (-) \text{---} + \quad [2.1]$$

$$= + (-) \text{---} + \quad [2.2]$$

$$= + (-) \text{---} + \quad [2.3]$$

Back EMF equations of each phase

$$= (\Theta) \quad [2.4]$$

$$= (\Theta - \frac{2}{3}) \quad [2.5]$$

$$= (\Theta - \frac{4}{3}) \quad [2.6]$$

Torque equations of each phase

$$= (\Theta) \quad [2.7]$$

$$= (\Theta - \frac{2}{3}) \quad [2.8]$$

$$= (\Theta - \frac{4}{3}) \quad [2.9]$$

Electromagnetic Torque equation

$$= + + \quad [2.1]$$

$$= \frac{2\Theta}{2} + \frac{\Theta}{2} \quad [2.1]$$

Electrical rotor angle

$$e = \frac{\Theta}{2} \quad [2.1]$$

Angular rotor speed

$$= \frac{\Theta}{2} \quad [2.13]$$

## 3. ZETA CONVERTER

Analysis of the zeta converter operating in discontinuous conduction mode is used for power factor correction. The main advantage of zeta converter is that it is a naturally isolated structure, which allows a regulated output voltage with only one power processing stage. With the exception of the zeta converter all others (buck, boost, buck-boost, cuk and sepic) have been employed to correct the power factor of power supplies. However they have their intrinsic limitations.

### OPERATION OF ZETA CONVERTER:

The zeta converter is operated in Discontinuous inductor current mode (DICM) to achieve wide range of speed control and power factor correction.

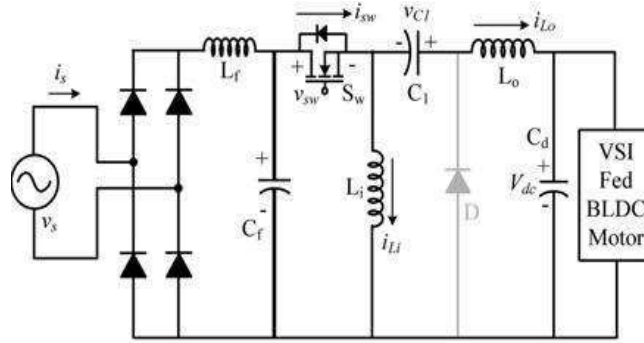

**Mode I :**

In this mode1, switch S<sub>w</sub> is ON position. When inductors L<sub>i</sub> and L<sub>o</sub> are getting charged, the intermediate capacitor C<sub>1</sub> is discharged . The dc link capacitor C<sub>d</sub> gets charged. In mode1, diode D is in off condition because positive polarity of the capacitor V<sub>c1</sub> is applied to diode. When the diode D is said to be in OFF condition a voltage applied to capacitor is V<sub>c1</sub>.

**Mode II :**

In mode 2, switch S<sub>w</sub> is OFF position. So there is no supply to the remaining part of the circuit. In mode 2, inductor L<sub>i</sub> and L<sub>o</sub> are discharged. the diode D starts conducting. Hence the voltage across C<sub>1</sub> and V<sub>dc</sub> gradually increases.

**Mode III:**

In mode 3, the switch S<sub>w</sub> is in OFF position and this mode is said to be in discontinuous mode of operation. The inductor L<sub>i</sub> completely discharges and the inductor current becomes zero. When the inductor current becomes zero, the capacitor V<sub>dc</sub> acts as source for VSI which is connected to BLDC. By this way voltage V<sub>dc</sub> also decreases in this mode.

**4. PROPOSED TOPOLOGY FOR BLDC MOTOR DRIVE SYSTEM**

The complete operation of BLDC motor drive is realized using a single voltage sensor. A electronic commutation of BLDC motor is utilized for reducing the switching losses.[2]

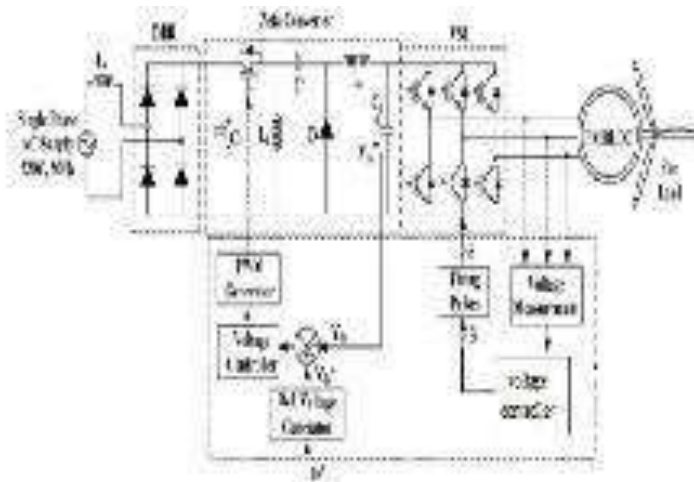

**Fig 4.1 Proposed PFC zeta converter fed BLDC motor drive**

**Design of PFC zeta converter:**

In switching period, the current flowing through inductor is discontinuous.

The duty ratio D for the zeta converter is

$$= \frac{V_{dc}}{V_{in}} + \frac{L_o}{L_i} \quad [4.1]$$

The permitted ripple current in input inductor L<sub>i</sub> and output inductor L<sub>o</sub> the inductor value L<sub>i</sub> and L<sub>o</sub> are given as

$$L_i = D \cdot V_{in} / 2 I_{in} f_s \quad [4.2]$$

$$L_o = (1-D) V_{dc} / \{ f_s \cdot (\Delta i_{L_o}) \} \quad [4.3]$$

Where  $f_s$  is the switching frequency

The value of intermediate capacitor  $C_1$  is

$$C_1 = D \cdot I_{dc} / \{f_s \cdot (\Delta V_{C1})\} \quad [4.4]$$

Here  $\Delta V_{C1}$  is the permitted ripple in  $C_1$ .

The value of DC link capacitor  $C_d$  is written as

$$C_d = I_{dc} / (2 \cdot \omega \cdot \Delta V_{dc}) \quad [4.5]$$

**Design of dc filter ( $L_f$  and  $C_f$ ):**

The filter capacitance at maximum is

$$C_f = \frac{I_{dc}}{2 \cdot \omega \cdot \Delta V_{dc}} \quad [4.6]$$

The additional value of inductance required is

$$L_f = \frac{1}{\omega^2 \cdot C_f} \quad [4.7]$$

**Control of proposed BLDC motor drive:**

The front-end PFC converter is controlled by approach called voltage follower and the converter generates the PWM pulses for the PFC converter switch for dc-link voltage control. The PFC zeta converter is operated in DICM by single voltage control loop.

Reference dc-link voltage  $V_{dc}^*$ ,

$$V_{dc}^* = k_v \cdot \omega \quad [4.8]$$

Generated voltage error signal,

$$e_{dc} = V_{dc}^* - V_{dc} \quad [4.9]$$

Voltage error signal is generated by comparing reference dc-link voltage ( $V_{dc}^*$ ) with sensed dc-link voltage ( $V_{dc}$ )  
Generated output voltage ( $V_{cc}$ ),

$$V_{cc} = (V_{dc} - 1) + \{ (V_{dc}^* - (V_{dc} - 1)) \} + V_{dc} \quad [4.10]$$

Controlled output voltage is generated by giving error voltage signal to PI controller

The PWM pulses is generated by comparing the output of voltage controller with a high-frequency saw-tooth signal ( $m_d$ )

$$\left\{ \begin{array}{l} V_{cc} < m_d, \text{ then } s_w = \text{on} \\ V_{cc} \geq m_d, \text{ then } s_w = \text{off} \end{array} \right. \quad [4.11]$$

**5. MATLAB SIMULATION CIRCUIT FOR BLDC MOTOR WITH ZETA CONVERTER**

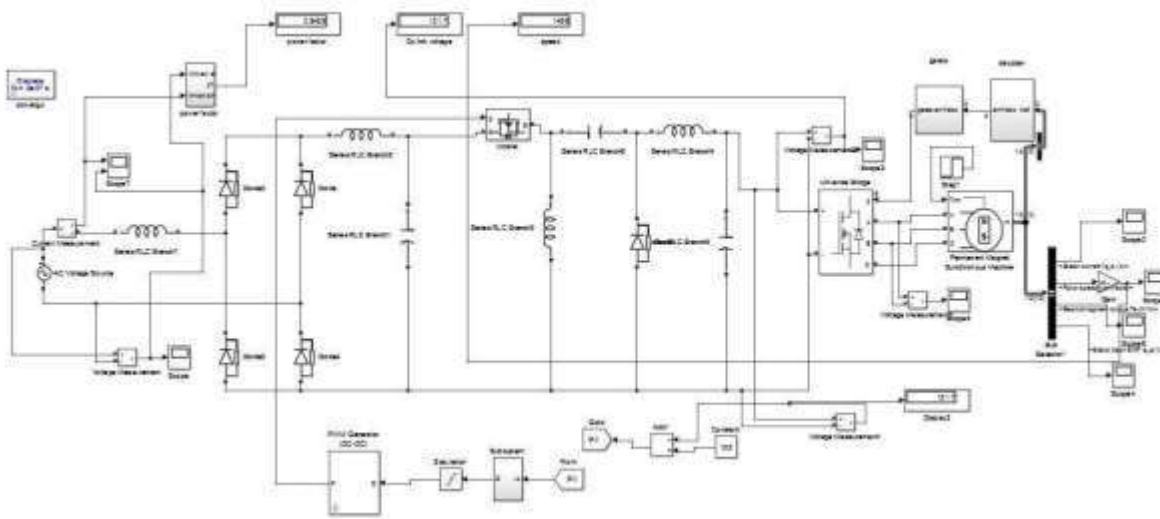

**Figure:5.1 MATLAB Simulation circuit for BLDC motor with zeta converter**

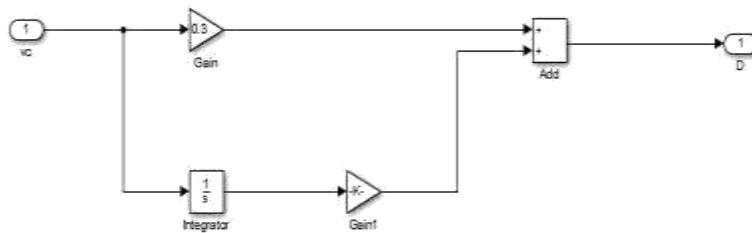

**6. RESULT ANALYSIS**

Simulation results were obtained using the proposed strategy to the BLDC motor has the following constants and ratings

Four pole,  $V_{rated} = 200\text{ V}$ ,  $R_{ph}$ (phase resistance) =  $0.7\Omega$ ,  $L_{ph}$ (phase inductance) =  $2.72\text{mH}$ ,  $K_b$ (back emf)

$= 88\text{v/Krpm}$ , Torque constant( $K_t$ )= $0.84\text{Nm/A}$  J(moment of inertia) =  $0.8\text{Kg-m}^2$

Controller gains:  $K_p = 0.3$  and  $K_i = 0.001$

Zeta converter parameters: input inductor ( $L_i$ )= $1000\mu\text{H}$ ,

Intermediate capacitor ( $C_1$ )= $400\text{ nF}$ ,

Output Inductor ( $L_o$ )= $3\text{mH}$ , DC link capacitor= $2000\mu\text{F}$ ,

DC filter inductance( $L_f$ )= $1.21\text{mH}$ ,

DC filter capacitance ( $C_f$ ) =  $330\text{nF}$ .

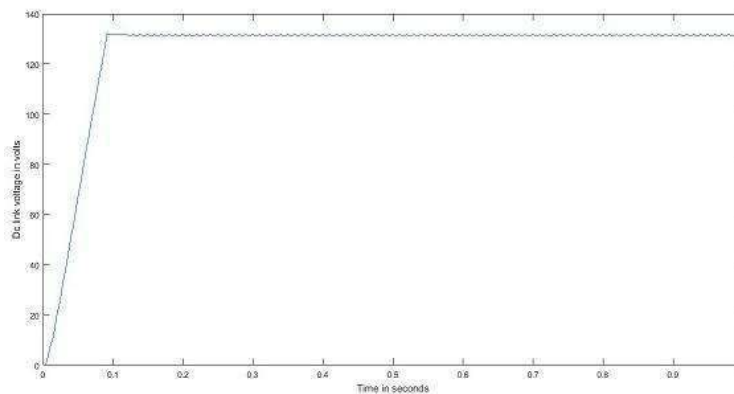

**Fig:6.1 DC link voltage for input voltage  $v_s$  is 220v**

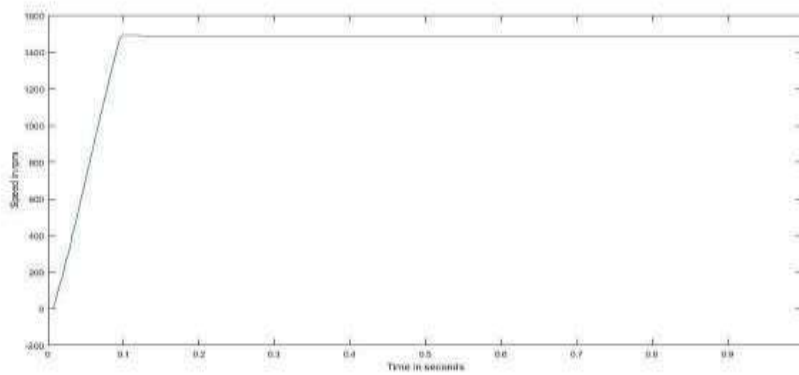

**Fig:6.2 Speed of BLDC motor when operating at 220v**

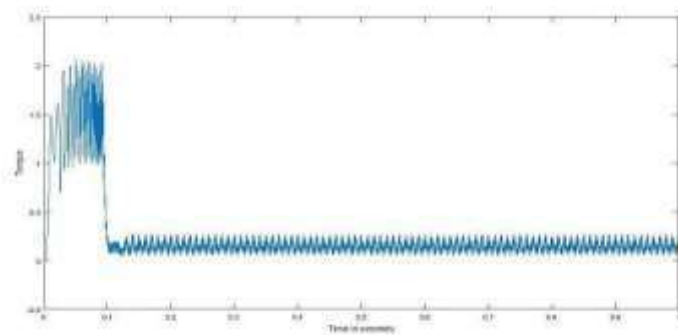

**Fig 6.3 Electromagnetic Torque ( $T_e$ ) of BLDC motor when operating at 220v**

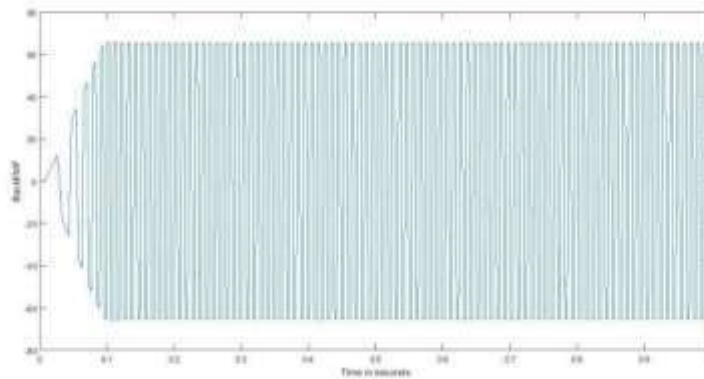

**Fig:6.4 Back emf ( $E_b$ ) of BLDC motor when operating at 220v**

**Simulated Results for various speeds and DC link voltages**

DC link voltage (V <sub>dc</sub> )	Actual speed of the motor(Nr) in rpm	Power factor(cosφ)
131.5	1486	0.958
122.8	1388	0.969
114	1289	0.962
105.3	1189	0.944
96.3	1090	0.921
87.7	991	0.900

**CONCLUSION**

A Simple control using a voltage follower approach has been used for voltage control and power factor correction of a PFC zeta converter fed BLDC motor drive. The speed of BLDC motor has been controlled by varying the dc-link voltage of VSI via the PFC zeta converter. The PFC zeta converter has been designed to operate in DICM, which required a voltage follower for dc-link voltage control. The PFC zeta converter fed BLDC motor drive has been simulated and results were obtained. The zeta converter is found to be effective in improving the power factor of the BLDC motor drive. The proposed drive system has been found suitable to various adjustable speed drives for many low power applications.

**REFERENCES**

1. Bhim Singh, VashistBist, "A Single Sensor based zeta converter Fed BLDC motor drive for fan applications," 2012 IEEE Fifth Power India conf., 19-22 December 2012, pp.1-6
2. Bhim Singh, VashistBist, "Power quality improvements in a zeta converter for brushless DC motor drives," *IET Sci. Meas. Technol.*, 2015, Vol. 9 (3), pp. 351-361.
3. S Nagapavithra, Dr.S Umamaheswari "Zeta converter fed BLDC Motor for power factor correction and control." *IEE Conference on ICEDSS, 4-5 march 2016, Namakkal, India.*
4. Akash Ghodake, Dr.M.S.Chavan "A Review paper on Zeta converter fed BLDC motor Drive," *ICRIEM, -16 ISBN; 978-81-932074-5-1, pp 465-469.* Anitha, R. Uthra and AkshayaSaraswathi, "Zeta
5. Converter Fed Brushless DC Motor Drive for powerFactor Correction in Low Power Applications" *IJCTA, 2016, Vol(14), pp 6583-6591*
6. Rahul P.Argelwar, V.S.Nandanwar, Sapna Verma, "PFC Zeta Converter Fed BLDC Motor Drive for Fan Applications" *IJRAT, 2014, Vol2(2)*
7. Sreedevi K J, C Sojy Rajan, "A New pulse width modulated PFC zeta converter fed Sensorless BLDC motor Drive with position feedback," *IJSR, 2014, vol(3) issue 7, pp 723-729*
8. Reshma Shabi, Dhanya B Nair, "Power factor corrected zeta converter Based switched mode power supply," *IJIREICE, 2016 vol(4) issue 9, pp 68-72*