



SOLAR POWERED UMBRELLA: A CLEAN TECH SOLUTION TO MITIGATE THE ADVERSE EFFECTS OF UV RADIATION ON OUTDOOR WORKERS

Sobin Sabu Thankachan

Research Associate, International Centre for Technological Innovations, Kerala, India

ABSTRACT

According to National Institute of Disaster Management (NDIM), 2422 people died due to heat wave in India, in the year 2015. Skin cancer, sun burns, heat stress and eye diseases are some of the other deleterious outcomes of overexposure to UV radiation. Additionally, outdoor workers are most afflicted due to prolonged daytime working hours. Although they are provided with various sun protection gears like umbrella, hat and so on, most of these accessories fail to satisfy their needs. This paper studies the detrimental effects of UV radiation on outdoor workers and existing protective measures taken in their work sites. All the information about the above elements were collected from secondary sources. After analyzing all the aspects, the paper proposes an innovative product concept to mitigate the hardships of outdoor workers. The concept is expected to provide better sun protection than existing equipment. It is titled as “Dual-purpose solar powered umbrella integrated with cooling fan and power bank”. Furthermore, the handle along with the shaft can be removed to convert the umbrella into a hat umbrella. Hence, the term dual-purpose is used in the title. This paper provides a competent concept which has the potential to assuage the hardships of outdoor workers.

KEYWORDS: *Heat stress, UV radiation, over exposure, protection, occupational illness, outdoor workers, solar umbrella.*

1. INTRODUCTION

Sunlight exposure is considered to have both positive and negative effects on human body. According to World Health Organization, UV radiation in small amounts is beneficial and plays a substantial role in producing Vitamin D. Nonetheless, different health issues, especially skin cancer and eye disease, are linked with over exposure to UV radiation. Moreover, outdoor workers are reported to be most afflicted, as they are committed to work under severe weather conditions all year round. The safety, health and well-being of the outdoor workers are prone to big risk due to dramatic change in the climate. The number of outdoor workers vulnerable to the impact of climate change is estimated to be approximately 2 billion. It has been reported that

agricultural workers have about 20 times more heat-related mortality than other industries (Golbabaei et al., 2016). The number of heat wave deaths was reported to have hiked from 754 to 2422 in India from the year 2006 to 2015 (National Institute of Disaster Management, 2016).

Furthermore, workers under occupational heat stress are observed to have mental health issues and psychological disorders (Tawatsupa et al., 2010). Such workers with low accommodation facilities and lack of coping mechanisms are threatened by mortality and morbidity (Nag, 2010).

A study was conducted recently on the different adaptive and protective strategies to reduce heat at workplace. According to this study, 21% of the workers opted access for cool water, while 20% voted for permission for leaving work to drink and

rest. Percentage of workers who preferred scheduled rest in shade, frequently drinking water and using personal protective equipments (like hat, mask, and sun glass) were 12% each. Additionally, 13% preferred access to shaded area. Planning heavy activities for early morning and evening, and avoiding alcohol, caffeine and sugar were each preferred by 5% of the workers (Golbabaei et al., 2016). Therefore, from the data it is clear that water and shade were the two common preferences among outdoor workers. Apparently, water could be more easily accessible in comparison because it is less likely that all work sites have a tree or shaded area. Therefore, it could be anticipated that portable and user-friendly equipment which can provide shade and cooling effect to the worker would mitigate the difficulties of finding a shade at new work sites. Solar powered umbrella with cooling fan is such an apparatus which could address the above issue suitably. There are plenty of such models available in the market currently. However, most of the existing products are not considered to be user-friendly by the outdoor workers.

2. RESEARCH METHODOLOGY

Detailed review of few existing solar powered umbrellas and similar sun protective equipments are provided. The data, about existing concepts, were collected for the purpose of this research from secondary sources. However, it was observed that most of the existing technologies were not user-friendly. Hence, a new product concept is introduced to assuage the conundrums of occupational heat stress, skin cancer and sunburn among outdoor workers.

3. RESULTS AND DISCUSSIONS

3.1 Existing Products and concepts

a. Kafya : Solar Powered Umbrella

Kafya solar powered umbrella was created by a Saudi-Palestinian company. The purpose was to help the Muslim pilgrims who are exposed to UV radiation for long hours during Haj. The umbrella consists of a solar panel on the top of the canopy, a fan is placed between the canopy and runner. A labeled diagram of umbrella parts is given below in Fig. 1 for better understanding. The solar panel produces enough electricity to power the fan, GPS, flashlight and to recharge power bank.

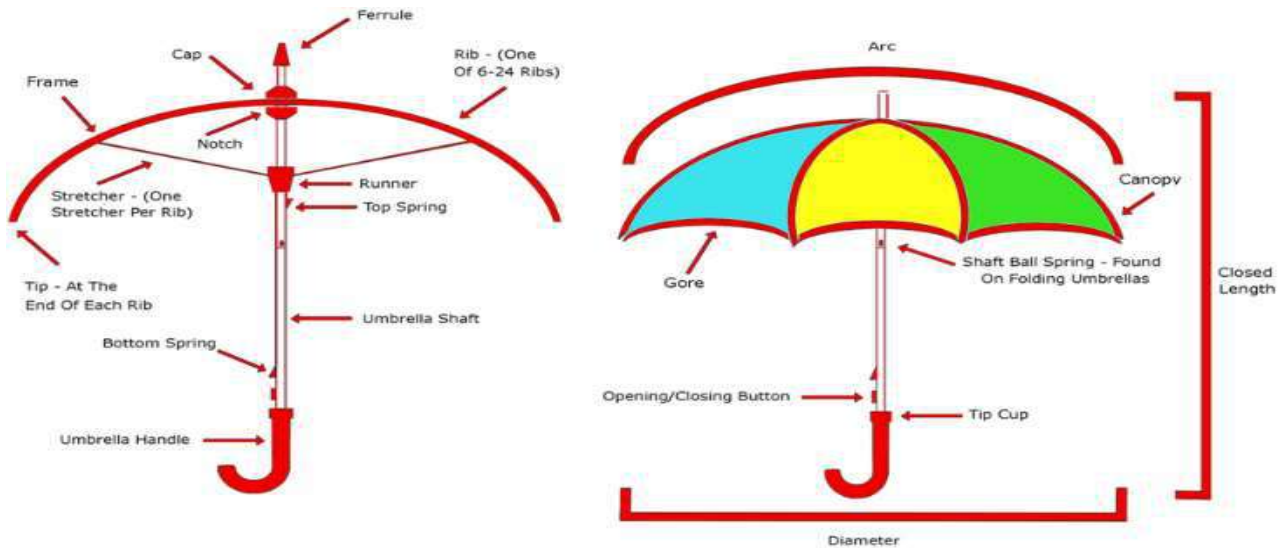

Figure 1: Labeled diagram of Umbrella (The London Umbrella Seller, 2018)

The GPS, flashlight and mobile charger are embedded in the umbrella handle. The GPS is meant to help the pilgrims find the location their companions. As envisaged in Saudi Vision 2030, numbers of Haj pilgrims are expected to reach 30 million annually by 2030. The mobile charger is also a boon to pilgrims as they found it extremely difficult to find unoccupied charging ports during Haj. However, this particular product is not suitable for outdoor workers, even though the features and cooling effect are appreciable, since it would be

difficult to work with an umbrella in one hand (Geek News Lab, 2016).



Figure 2: Kafya Solar Umbrella (Geek News Lab, 2016)

b. Chinese Solar Powered Umbrella

Numerous companies introduced similar products with adequate upgrades in the design and this is one of the Chinese versions of solar powered umbrella. This version, unlike the Kafya umbrella, neither has flashlight nor GPS system. Nevertheless, the solar panels are detachable, thereby, allowing the users to remove the panel during monsoon season. In other words, customers can use the same umbrella all year round, making it more economical.



Figure 3: Chinese Solar Umbrella (Alibaba n.d.)

c. Solar Cooling Caps and Hat umbrella

Hat umbrella is also a concept that was adopted by many companies, which led to development of various concept designs. Moreover, compared with the solar umbrella concept, this product would be more user-friendly for outdoor workers as they could mount it on their head while working. The Fig. 4 and Fig. 5 show solar cooling cap and patented solar cap respectively. Although, these designs are compact and convenient, the cooling effect and shade given is not adequate as that given by solar umbrellas.



Figure 4: Solar fan cap (Indiamart, 2016)

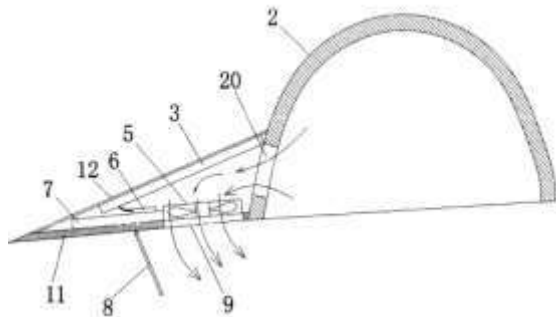

Fig 5: Patented solar cooling safety cap (Google Patents, 2011)

On the other hand, hat umbrellas, as shown in Fig. 6, usually provide more shade than caps and are hands-free equipment as well. Therefore, a hat umbrella with a cooling fan would be an excellent sun protective equipment for outdoor workers, especially farmers. Fig. 7 shows some common sun safety measures followed.



Figure 6: Hat Umbrella (Amazon, 2016)

	Slip on SPF30 or higher sunscreen and apply every two hours.
	Slap on a protective broad brimmed hat.
	Slide on wrap around sunglasses that comply with Australian standards.
	Slip on sun protective clothing.
	Seek shade where possible.

Figure 7: Sun Safety Measures from Queensland Government (Workplace Health and Safety Electrical Safety Office Workers' Compensation Regulator, 2019)

3.2 Proposed Concept

The concept was developed to provide a suitable equipment for the outdoor workers in order to allow them work conveniently without being affected by over exposure of UV radiation.

a. Objectives:

- The main objective is to minimize the rate of sunburns, fatigues and other health issues due to extreme weather conditions, especially among farmers, traffic policemen, watchmen and other labors who work under the sun all day.
- To integrate a solar powered cooling fan within an umbrella to reduce the intensity of heat.
- To provide a dual purpose umbrella that can be used as a hat umbrella as well as an ordinary umbrella. Hence, it would be a dual-purpose as well as an economical umbrella for working class.
- To provide an integrated mobile phone charging facility within the umbrella, so as to use solar power to charge the power bank installed inside the handle. Therefore, the need for carrying additional power bank would be eliminated.

b. Features in detail:

- The umbrella consists of a cooling fan situated in its inner top end.

- A USB mobile charger along with a battery inside the handle at the end of the shaft.
- The solar panel provides electricity to the fan as well as to the battery.
- The shaft of the umbrella can be removed and fixed on the head of the user with help of the adjustable head band. In this stage, electricity from the solar panel is sent to the fan alone.
- The solar panel can be removed from the umbrella during monsoon and it can be used as a

normal umbrella. Hence, making it an all-weather umbrella.

c. Design Specifications

Fig. 8 above shows three different arrangements of the umbrella. The first arrangement (a) is the umbrella with the shaft (5). The solar panel (1) is on top of the canopy (9). Below the canopy come the foldable fan (2) and its individual switch (8) which turns off the fan automatically when folded. The shaft coupling (3) comes below the fan.

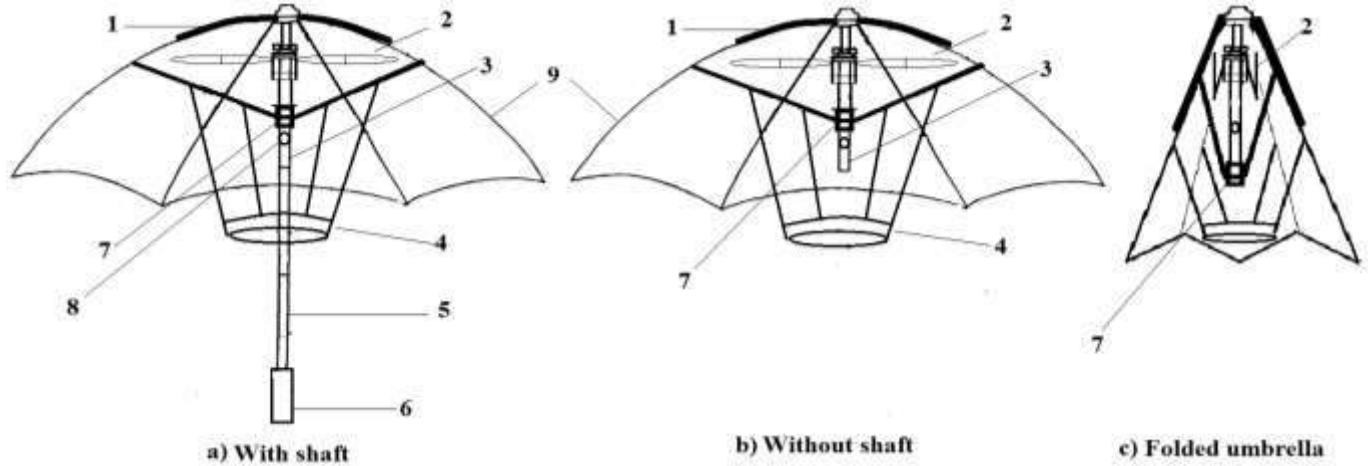

Figure 8: Design of the proposed concept

Item No.	Item Name
1.	Solar panel
2.	Cooling Fan
3.	Shaft coupling
4.	Head band
5.	Shaft
6.	Handle
7.	Runner
8.	Fan on/off switch
9.	Canopy

Table 1: Parts list

As shown in Fig. 7, under the coupling comes the head band (4) which can be folded upwards when not used. Finally, at the bottom comes the handle (6) integrated with power bank, charging circuit and charging plugs.

The second arrangement (b) above represents the umbrella after removing the shaft (5). The shaft is removed from a point few centimeters below the runner (7). It can be mounted on the user’s head using the head band (4).The end of the shaft coupling (3) is high enough to prevent any contact with the user’s head.

The third arrangement (c) is the closed state of the hat umbrella. It can be seen in the figure that the fan is also folded so as to compactly accommodate it inside the canopy (9)

As shown in the Table 1, the cost is estimated to be around Rs. 3,170/- . The equipment is anticipated to cost much lower when mass produced.

Table 2: Cost and specifications of the concept

Sl.no	Item	Specification	Required amount	Rate	Cost (INR)
1.	Fabrics	Nylon Taffeta	3 meters	50	150
2.	Removable Shaft assembly and Ribs.	Stainless steel	1 unit	450	450
3.	Handle	PVC	1 unit	250	250
4.	Head Band	56cm dia, Elastic	1 unit	150	150
5.	Fan	(3v, 0.2A)	1 unit	120	120
6.	Solar panels	(6v, 0-200mA, 0.6-1W)	4 unit	250	1000
7.	Battery	(8000mAH)	1 unit	900	900
8.	Charging circuit	(in and out)	1 unit	150	150
TOTAL					3,170/-

d. Potential major applications and users

- As hat umbrella for farmers who work under sun, in agricultural fields, without protection.
- As a cooling umbrella as well as a power bank for traffic policemen who spend hours in the busy traffic during daytime.
- As a health care equipment for daytime pedestrians and commuters.
- As a protection from sun for watchmen who needs to spend hours under the sun.
- As a sun protection equipment for daily wage labors working in construction industries.
- As a sun protection equipment for labors working in salt fields.
- As sun protection gear for fishermen working in the sea.

4. CONCLUSION AND RECOMMENDATIONS

In conclusion, the adverse effects of over exposure to sunlight, including skin cancer, sunburn, heat stroke and heat stress, are hiking rapidly nowadays. Outdoor workers are more prone to these hazards as they spend more time under sun. It is evident that, workers need to drink water and take rest under shade frequently in between their work to avoid heat stress. Apparently, an easiest way to get shade from sunlight would be a portable personal equipment. However, existing personal gears, used by workers, are inadequate to resolve all the present issues. The reason can be attributed to lack of easiness to use these devices while working. Thus, it

is imperative to develop a new equipment, like the concept discussed above, to alleviate the hardships of outdoor workers. It could be expected that the proposed design of “Dual-purpose solar powered umbrella integrated with cooling fan and power bank” would assist the workers in fighting heat related miseries.

Recommendations

- The prototype could be given to outdoor workers for testing and feedback.
- The price could be reduced through mass production.
- Utilization of light-weight solar panels and batteries should be considered in order to reduce the overall weight of the equipment.
- Organizations/companies could provide the solar umbrella to outdoor workers in work sites.

REFERENCES

- 1) National Institute of Disaster Management (2016) Heat Wave in India: Documentation of State of Telangana and Odisha. Available at: https://nidm.gov.in/PDF/pubs/heat_wave_18.pdf
- 2) World Health Organization (2009) Global disease burden from solar ultraviolet radiation. Available at: <https://www.who.int/wv/resources/archives/fs305/en/> [Accessed 30 September 2019].
- 3) Golbabaei, F., Monazzam, M. R., Aval, M. Y., Allahyari, T., Taban, E. and Shendi, M. R. A. (2016) Investigation of heat stress and heat strain in outdoor workers: a case study in Iran. *Journal of Paramedical Sciences (JPS)*, 7, (4) 30-38. Published by Semantic Scholar. Available at: https://pdfs.semanticscholar.org/b267/6171c34a980422b57ff137c9001e63920a5b.pdf?_ga=2.222662424.2004488843.1569827563-784575595.1569827563 [Accessed 29 September 2019].
- 4) Taxwatsupa, B., Lim, L. L., Kjellstrom, T., Seubsman, S. A., Sleight, A. (2010) The association between overall health, psychological distress, and occupational heat stress among a large national cohort of 40,913 Thai workers. *Global health action*, 3, (1) 1-10. Published by Taylor and Francis. Available at: <https://www.tandfonline.com/doi/pdf/10.3402/gha.v3i0.5034?needAccess=true> [Accessed 30 September 2019].
- 5) Nag, P. K. (2010) Extreme heat events--a community calamity. *Industrial health*, 48, (2) 131-3.
- 6) Geek News Lab (2016) Kafya: Solar Powered Umbrella Includes Fan, GPS, Flash Light and USB Charging. Available at: <https://geeknewsclub.com/kafya-solar-powered-umbrella/> [Accessed 30 September 2019].
- 7) The London Umbrella Seller (2018) Your Complete Guide To All The Parts of an Umbrella. Available at: <http://thelondonumbrellaseller.com/your-complete-guide-to-all-the-parts-of-an-umbrella/> [Accessed 30 September 2019].
- 8) Alibaba n.d, viewed September 29 2019, <https://www.alibaba.com/product-detail/New-UV-Protcet-Can-Charge-Cell_62006977445.html?spm=a2700.7724857.normalIst.6.716588eeybBEIT&s=p>

- 9) Indiamart (2016) Solar Cap with Fan (Cooling Cap). Available at: <https://www.indiamart.com/proddetail/solar-cap-with-fan-cooling-cap-12463302088.html> [Accessed 30 September 2019].
- 10) Google Patents (2011) Cooling hat cap has an internal face and suction blower function. Available at: <https://patents.google.com/patent/CN102293468A/en?q=solar&q=cooling+fan&q=cap&oq=solar+cooling+fan++cap> [Accessed 29 September 2019].
- 11) Amazon (2016) Luvint 36" Diameter Elastic Fishing Gardening Folding Umbrella Hat Headwear. Available at: <https://www.amazon.com/Luvint-Diameter-Gardening-Umbrella-Headwear/dp/B013QVOMYS> [Accessed 30 September 2019].
- 12) Workplace Health and Safety Electrical Safety Office Workers' Compensation Regulator (2019) Sun safety at work. Available at: <https://www.worksafe.qld.gov.au/injury-prevention-safety/hazardous-exposures/sun-safety> [Accessed 30 September 2019].